

**Universal Mobile Telecommunications System (UMTS);  
Radio Interface for Broadcast/Multicast Services  
(3GPP TR 25.925 version 3.3.0 Release 1999)**



---

**Reference**

RTR/TSGR-0225925UR3

---

**Keywords**

UMTS

**ETSI**

---

650 Route des Lucioles  
F-06921 Sophia Antipolis Cedex - FRANCE

Tel.: +33 4 92 94 42 00 Fax: +33 4 93 65 47 16

Siret N° 348 623 562 00017 - NAF 742 C  
Association à but non lucratif enregistrée à la  
Sous-Préfecture de Grasse (06) N° 7803/88

---

**Important notice**

Individual copies of the present document can be downloaded from:

<http://www.etsi.org>

The present document may be made available in more than one electronic version or in print. In any case of existing or perceived difference in contents between such versions, the reference version is the Portable Document Format (PDF). In case of dispute, the reference shall be the printing on ETSI printers of the PDF version kept on a specific network drive within ETSI Secretariat.

Users of the present document should be aware that the document may be subject to revision or change of status. Information on the current status of this and other ETSI documents is available at <http://www.etsi.org/tb/status/>

If you find errors in the present document, send your comment to:  
editor@etsi.fr

---

**Copyright Notification**

No part may be reproduced except as authorized by written permission.  
The copyright and the foregoing restriction extend to reproduction in all media.

© European Telecommunications Standards Institute 2000.

All rights reserved.

---

## Intellectual Property Rights

IPRs essential or potentially essential to the present document may have been declared to ETSI. The information pertaining to these essential IPRs, if any, is publicly available for **ETSI members and non-members**, and can be found in ETSI SR 000 314: "*Intellectual Property Rights (IPRs); Essential, or potentially Essential, IPRs notified to ETSI in respect of ETSI standards*", which is available from the ETSI Secretariat. Latest updates are available on the ETSI Web server (<http://www.etsi.org/ipr>).

Pursuant to the ETSI IPR Policy, no investigation, including IPR searches, has been carried out by ETSI. No guarantee can be given as to the existence of other IPRs not referenced in ETSI SR 000 314 (or the updates on the ETSI Web server) which are, or may be, or may become, essential to the present document.

---

## Foreword

This Technical Report (TR) has been produced by the ETSI 3<sup>rd</sup> Generation Partnership Project (3GPP).

The present document may refer to technical specifications or reports using their 3GPP identities, UMTS identities or GSM identities. These should be interpreted as being references to the corresponding ETSI deliverables.

The cross reference between GSM, UMTS, 3GPP and ETSI identities can be found under [www.etsi.org/key](http://www.etsi.org/key) .

# Contents

Foreword.....	5
1 Scope.....	6
2 References.....	6
3 Abbreviations.....	7
4 Overview of Point-to-multipoint Services and Requirements.....	7
5 Common Model.....	8
6 Cell Broadcast Service CBS.....	9
6.1 CBS (GSM).....	9
6.1.1 Impact on UTRAN functions.....	9
6.1.1.1 Network and Protocol Architecture.....	9
6.1.1.2 BM-IWF.....	10
6.1.1.2.1 Broadcast/Multicast Distribution for GSM based CB messages.....	10
6.1.1.2.2 Broadcast/Multicast Flow Control.....	11
6.1.1.2.3 Administrative Data Management.....	11
6.2 CBS (ANSI-41).....	11
6.2.1 Impact on UTRAN functions.....	11
6.2.1.1 Network and Protocol Architecture.....	11
6.2.1.2 BM-IWF.....	12
6.2.1.2.1 Broadcast/Multicast Distribution for ANSI-41 Core Network based CB messages.....	12
6.3 Radio Interface Requirements.....	12
6.3.1 Protocol architecture.....	13
6.3.2 Examples of procedures.....	14
6.3.2.1 CB message storage in BMC entity and counting of CB message repetition.....	14
6.3.2.2 BMC message scheduling.....	17
6.3.2.3 Activation of CB message reception by User.....	19
6.3.2.4 CB message reception with DRX.....	20
6.3.2.5 Overflow.....	22
6.3.2.6 Underflow.....	23
6.3.3 UE capabilities with respect to CBS.....	24
6.3.4 CBS allocated radio resources.....	25
6.3.5 Impact on RRC.....	25
6.3.5.1 RRC Functions.....	25
6.3.5.2 CB related system information.....	25
6.3.6 Impact on BMC.....	26
6.3.6.1 R99-requirements:.....	26
6.3.6.2 BMC Functions.....	26
6.3.6.3 BMC Message Scheduling.....	26
6.3.6.4 CBS Discontinuous Reception (DRX).....	27
6.3.6.4.1 Level 1 scheduling: Scheduling on FACH regarding logical channel CTCH.....	27
6.3.6.4.2 Level 2 scheduling: DRX on CTCH content.....	28
6.3.6.4.2.1 Case 1: O&M system has not requested CB-DRX schedule period.....	29
6.3.6.4.2.2 Case 2: O&M system has requested a CB-DRX schedule period.....	30
6.3.7 Impact on RLC.....	30
6.3.7.1 RLC Functions.....	30
6.3.8 Impact on MAC.....	31
6.3.8.1 MAC Functions.....	31
6.3.9 Other items.....	31
6.3.9.1 CBS Compression.....	31
6.3.9.2 CBS Index.....	31

7	PTM-Multicast Service (GPRS).....	31
8	PTM-Group Call Service (GPRS).....	31
9	IP Multicast Service (GPRS).....	31
10	Multimedia Distribution Service (UMTS) .....	32
	<b>Annex A: Functions related to MDS (ffs.) .....</b>	<b>33</b>
	<b>Annex B: Change history .....</b>	<b>34</b>

---

# Foreword

This Technical Report (TR) has been produced by the 3<sup>rd</sup> Generation Partnership Project (3GPP).

The contents of the present document are subject to continuing work within the TSG and may change following formal TSG approval. Should the TSG modify the contents of the present document, it will be re-released by the TSG with an identifying change of release date and an increase in version number as follows:

Version x.y.z

where:

- x the first digit:
  - 1 presented to TSG for information;
  - 2 presented to TSG for approval;
  - 3 or greater indicates TSG approved document under change control.
- y the second digit is incremented for all changes of substance, i.e. technical enhancements, corrections, updates, etc.
- z the third digit is incremented when editorial only changes have been incorporated in the document.

---

# 1 Scope

The present document shall provide a general overview on radio interface related aspects of broadcast/multicast services. This report covers stage 2 and stage 3 aspects of the radio interface.

This report is organised as follows: clause 4 gives an overview on the broadcast/multicast services and their requirements. Clause 5 provides a common model and describes aspects common to all point-to-multipoint services. Clauses 6 to 10 are devoted to the different broadcast/multicast service categories. Each service specific clause describes the requirements on the interfaces. In these subclauses the impacts on the interface functions and the protocol aspects are described. The present document covers only those items which are in the scope of 3GPP TSG RAN WG 2. Information from Technical Specifications or other documents are provided when it is necessary to understand the requirements described.

**Table 1.1: Schedule of the broadcast/multicast services onto the UMTS phases and annual releases**

Phase	Release	Broadcast/multicast service
1	1999	Cell Broadcast Service CBS (GSM) Cell Broadcast Service (ANSI-41)

NOTE: A decision to map the services to phases/releases is required for all other broadcast/multicast services.

---

# 2 References

The following documents contain provisions which, through reference in this text, constitute provisions of the present document.

- References are either specific (identified by date of publication, edition number, version number, etc.) or non-specific.
- For a specific reference, subsequent revisions do not apply.
- For a non-specific reference, the latest version applies.

- [1] 3GPP TS 22.100: "UMTS Phase 1".
- [2] 3GPP TS 22.101: "UMTS Service Principle".
- [3] 3GPP TS 22.105: "Services and Service Capabilities".
- [4] 3GPP TS 25.301: "Radio Interface Protocol Architecture".
- [5] 3GPP TS 25.302: "Services provided by the Physical Layer".
- [6] 3GPP TS 25.303: "UE Functions and Interlayer Procedures in Connected Mode".
- [7] 3GPP TS 25.304: "UE Procedures in Idle Mode".
- [8] 3GPP TS 25.321: "MAC Protocol Specification".
- [9] 3GPP TS 25.322: "RLC Protocol Specification".
- [10] 3GPP TS 25.331: "RRC Protocol Specification".
- [11] 3GPP TS 22.003: "Digital cellular telecommunications system (Phase 2+); Principles of telecommunication services supported by a GSM Public Land Mobile Network (PLMN)".
- [12] 3GPP TS 23.060: "General GPRS Service description; Stage 2".
- [13] 3GPP TS 23.041: "Technical realization of Cell Broadcast Service (CBS)".

- [14] GSM 03.61: "Digital cellular telecommunications system (Phase 2+); Point To Multipoint Multicast Service Description; Stage 2".
- [15] 3GPP TS 23.110: "UMTS Access Stratum, Services and Functions".
- [16] 3GPP TS 25.324: "Broadcast/Multicast Protocol BMC".
- [17] 3GPP TS 24.012: "Short Message Service Cell Broadcast (SMS) Support on the Mobile Radio Interface".
- [18] 3GPP TS 25.402: "Synchronization in UTRAN Stage 2".
- [19] 3GPP TS 25.419: "Service Area Broadcast Protocol SABP".
- [20] TIA/EIA-637-A: "TR45 – Short Message Service for Spread Spectrum Systems".

---

## 3 Abbreviations

For the purposes of the present document, the following abbreviations apply:

BCCH	Broadcast Control Channel
BCH	Broadcast Channel
BMC	Broadcast/Multicast Control
BM-IWF	Broadcast/Multicast Interworking Function
CB	Cell Broadcast
CBS	Cell Broadcast Service
CCCH	Common Control Channel
CTCH	Common Traffic Channel
CTCH-BS	Common Traffic Channel Block Set
DRX	Discontinuous Reception
FACH	Forward Access Channel
IP	Internet Protocol
IP-M	IP Multicast
MDS	Multimedia Distribution Service
PTM	Point-to-Multipoint
PTM-G	PTM Group Call
PTM-M	PTM Multicast
SMS	Short Message Service
SMS-CB	SMS Cell Broadcast
UE	User Equipment
UMTS	Universal Mobile Telecommunication System
TB	Transport Block
TR	Technical Report
TS	Technical Specification
TrCH	Transport channel
UTRAN	UMTS Terrestrial Radio Access Network

---

## 4 Overview of Point-to-multipoint Services and Requirements

It is agreed to have service continuity for GSM/GPRS point-to-multipoint services in UMTS ([1] and [2]). This means that the user gets the same service behaviour as he knows it from GSM or GPRS. The services are Cell Broadcast Service [13] and Point-to-multipoint Multicast, Point-to-multipoint Group Call and IP Multicast [14].

Combined with the UMTS service classification given in [2] the service classification shown in Figure 1 could be used as a starting point. The figure contains the view in terms of Radio Access Bearer services and should not be applied for higher layers where other categories of services may exist. Future work may result in changes of Figure 1.



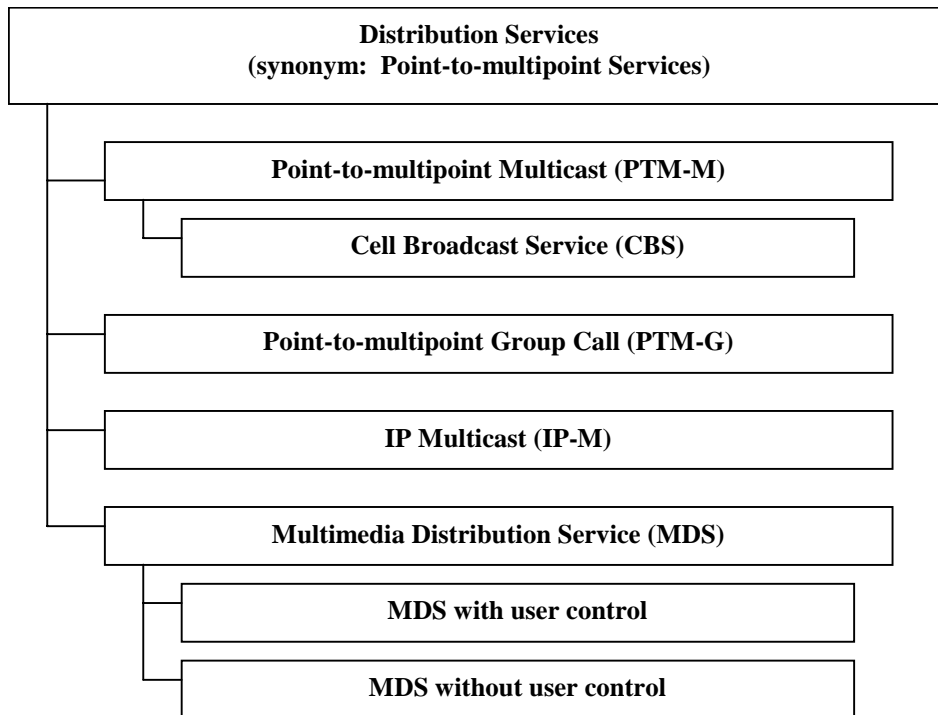

**Figure 4.1: Structure of point-to-multipoint services**

Table 4.1 gives an overview of broadcast/multicast services as recognised on the radio interface.

**Table 4.1: Radio Interface related attributes of broadcast/multicast services [12]**

Attributes	CBS (SMS-CB)	PTM Multicast	PTM Group call	IP- multicast
UE modes	Idle Connected			
Logical Channels	CTCH	CTCH	CTCH	CTCH
Necessity of separate control channel	Yes BCCH			
Transport Channels	FACH			
Physical Channels	Secondary CCPCH			
DRX Mode	Yes	Yes	No	Yes
Primary addressing	GEO area	Subscriber group	Subscriber group	Subscriber group
Secondary addressing	---	GEO area	GEO area	---
Present subscribers known	No	No	Yes	Yes
Ciphering	No	No	Yes	Yes
Reliable delivery	No	No	Optional	Yes

## 5 Common Model

The Common Traffic Channel (CTCH) [4] is provided by the MAC sublayer for support of broadcast/multicast services. It is presently assumed that the CTCH can be used for all categories of broadcast/multicast services.

For CBS, the CTCH is mapped to a FACH transport channel. The FACH is also a candidate to be used for multicast services in future releases. This possibility will be further investigated in this report.

---

## 6 Cell Broadcast Service CBS

This clause contains the requirements derived from GSM and ANSI-41 specifications of Cell Broadcast Service and the analysis of the impact on the radio interface Uu.

The main requirements for Release 99 are:

- service continuity (i.e. no degradation of the GSM and ANSI-41 CBS as seen by users);
- the restrictions regarding the radio interface which are given in GSM or ANSI-41 does not remain any longer;
- the content of this clause should be a basis for future broadcast/multicast service developments;
- minimising the power consumption by use of intelligent scheduling schemes for CB messages.  
(GSM CB message discontinuous reception (CBS DRX) should become mandatory).

The analysis of 3G CB service (3G-CBS) integration is done top-down. It starts with the network and protocol architecture applicable on each interface.

In subclause 6.1 the impact of CBS (GSM) on UTRAN functions is described. This subclause provides all information on the network level needed to derive the requirements for the radio interface.

In subclause 6.2 the impact of CBS (ANSI-41) on UTRAN functions is described.

Subclause 6.3 discusses the requirements on the radio interface.

Further special radio requirements are listed in subclauses related to each (sub-)layer of the radio interface.

The functions related to the CBC-RNC reference point are not in the scope of RAN WG2.

### 6.1 CBS (GSM)

#### 6.1.1 Impact on UTRAN functions

##### 6.1.1.1 Network and Protocol Architecture

Figure 6.1 summarises the network and protocol architecture chosen for Release 1999 by S2, T2, R3 and R2. Note that the Cell Broadcast Centre is integrated into the Core Network.

It is aimed to define a radio interface protocol architecture that is independent of the chosen configuration of the CBC-RNC reference point.

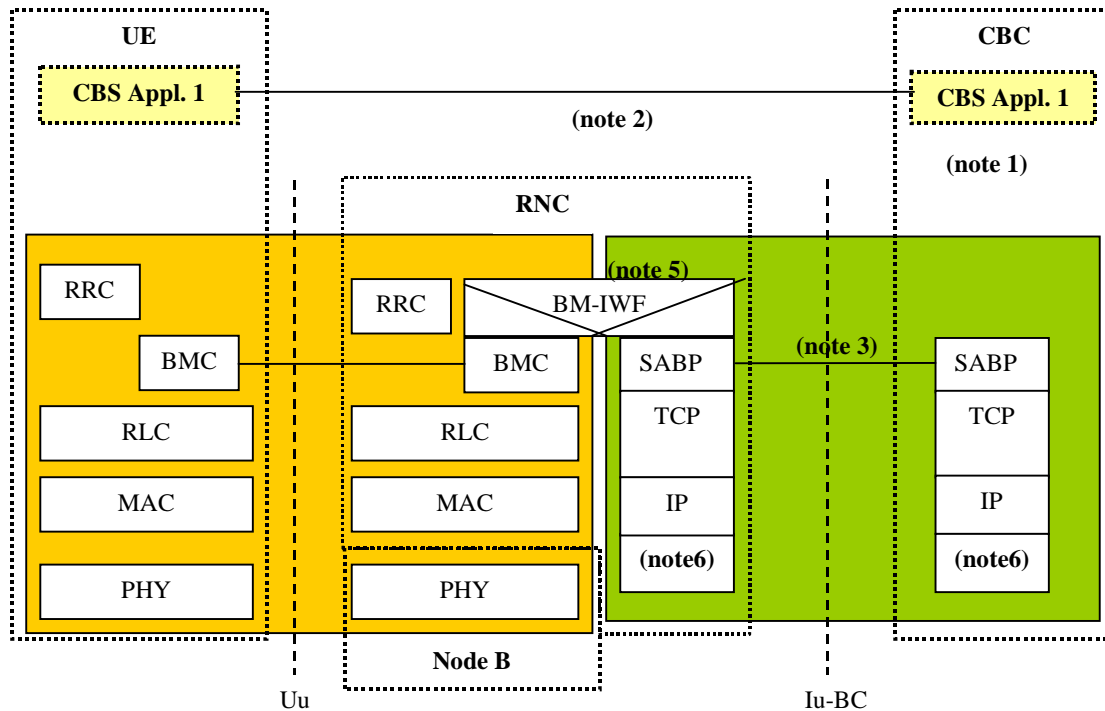

**Figure 6.1: General Protocol Architecture when RNS is connected to UMTS Core Network**

NOTE 1: S2 has chosen to integrate the CBC into the Core Network

NOTE 2: CBS Application protocol is to be defined by TSG T2

NOTE 3: R3 is responsible for specifying SABP (Service area broadcast protocol, TS 25.419 [19]).

NOTE 4: This relay function provides IP routing to RNC.

NOTE 5: The CBC sends a CB message together with its scheduling information once to an RNC (see 3GPP TS 23.041 and 3G 25.419). The BM Interworking Function (BM-IWF) distributes CB messages received over Appl. 3 to all BMC instances indicated in the delivered cell list. For future releases of UMTS a new function would be necessary if a geographical area is delivered instead of a cell list.

NOTE 6: The lower layer on the Iu-BC interface uses AAL5 over ATM (packet transmission).

In the following, the data unit delivered from/to the CBS Application 1 protocol is denoted as "CB message". This data unit is described in TS 23.041. It comprises the following CB message parameters:

*Number-of-Pages (1 octet),*  
*(CBS-Message-Information-Page 1 (82 octets), CBS-Message Information-Length 1(1 octet)) [,*  
 ...  
*(CBS-Message-Information-Page 15 (82 octets), CBS-Message Information-Length 15)(1 octet)]*

This implies a maximum CB message length of  $1 + 15 (82+1) = 1246$  octets.

NOTE 8: In TS 25.419 [19], the maximum CB message length of 1246 octets is kept by R3.

## 6.1.1.2 BM-IWF

### 6.1.1.2.1 Broadcast/Multicast Distribution for GSM based CB messages

The main objective of the BM-IWF in RNC is to distribute the received CB messages towards the BMC entities configured per cell for further processing. This is done in accordance with the associated schedule information.

The radio interface-related schedule information associated with each CB message is described in 3GPP TS 23.041 and is provided in Table 6.1 for information.

**Table 6.1: CB Information Elements sent from CBC to RNC for further management**

CB Information Element	Description
Message ID	Source and type of CB message
Serial Number	Serial number: Each type of CB message can vary. These variations are expressed by the serial number. The Serial Number consists of three information elements: <b>Geographical scope</b> (values: immediate cell wide, PLMN wide, LA wide, cell wide), <b>Message Code</b> , <b>Update Number</b> .
Data Coding Scheme	Data coding scheme used
Category	Category of the CB message: HIGH: CB message should be broadcast at the earliest opportunity NORMAL: CB message should be broadcast within the associated Repetition Period BACKGROUND: CB message with lowest transmission priority
Repetition Period	Period of time after which broadcast of the CB message should be repeated
Number Of Broadcast Requested	Number of times the CB message is to be broadcast 0: infinitely 1...n: finite number of repetitions

#### 6.1.1.2.2 Broadcast/Multicast Flow Control

When the BMC cannot provide any longer the requested service the BMC is said to be congested. The Broadcast/Multicast Flow Control function takes measures to inform the data source about this congestion situation and to reduce the amount of data to be broadcast or multicast by the congested BMC entity.

#### 6.1.1.2.3 Administrative Data Management

The CBC can request the status of the CBS messages which are currently broadcast. This implies a function that can collect status information which is then reported to the CBC.

## 6.2 CBS (ANSI-41)

### 6.2.1 Impact on UTRAN functions

#### 6.2.1.1 Network and Protocol Architecture

Figure 6.2 summarises the network and protocol architecture chosen for Release 1999 by S2, T2, R3, R2 and 3GPP2.

It is aimed to define a radio interface protocol architecture that is independent of the chosen configuration of the CBC-RNC reference point.

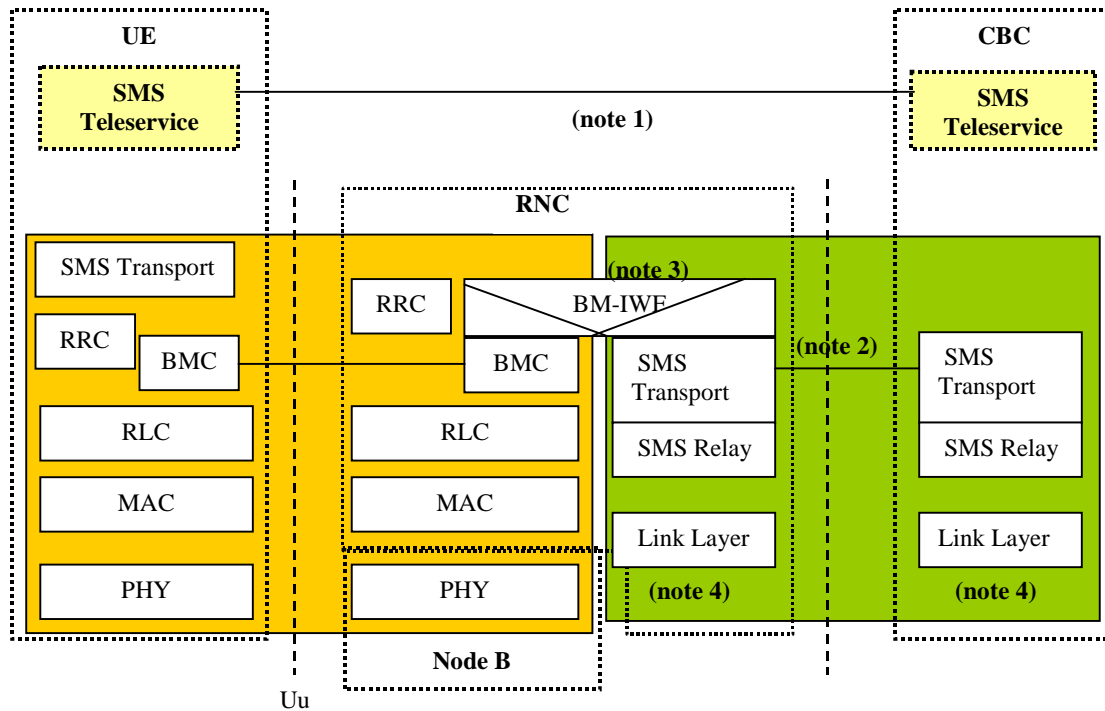

**Figure 6.2: General Protocol Architecture when RNS is connected to ANSI-41 Core Network**

NOTE 1: This interface is defined in ANSI-41, [20] TIA/EIA-637-A: "TR45 – Short Message Service for Spread Spectrum Systems".

NOTE 2: This interface is defined in [20] TIA/EIA-637-A: "TR45 – Short Message Service for Spread Spectrum Systems".

NOTE 3: The BM Interworking Function (BM-IWF) distributes CB messages received to all BMC instances indicated in the delivered cell information.

NOTE 4: The SMS Relay Layer is defined in [20] TIA/EIA-637-A: "TR45 – Short Message Service for Spread Spectrum Systems". 3GPP2 do not specify any specific Link layer. This could be implementation specific.

In the following, the data unit delivered from/to the SMS Transport layer protocol is denoted as "ANSI-41 CB message". This data unit is described in TIA/EIA-637-A [20].

## 6.2.1.2 BM-IWF

### 6.2.1.2.1 Broadcast/Multicast Distribution for ANSI-41 Core Network based CB messages

The main objective of the BM-IWF in RNC is to distribute the received ANSI-41 CB messages towards the BMC entities configured per cell for further processing. This is done in accordance with the associated distribution information.

The ANSI-41 CB messages are described in TIA/EIA-637-A. Each ANSI-41 CB message is to be sent once as soon as possible over the radio interface. Note that no other scheduling is required in the RNC as it is for UMTS based CB messages.

## 6.3 Radio Interface Requirements

The transmission of CB messages from RNC to UEs via Node B and the cells under its control is in the scope of TSG RAN WG2.

### 6.3.1 Protocol architecture

Figure 6.2 shows those parts of the radio interface protocol stack which are relevant for CBS. The shown architecture has been selected by RAN WG2.

In the user plane, above the RLC sublayer, a BMC sublayer is introduced (which is assumed as transparent for all services except broadcast/multicast).

At the UTRAN side, the BMC sublayer shall consist of one BMC protocol entity per cell. It is also assumed that each broadcast/multicast requires a single CTCH, which is provided by MAC-c/sh, through the RLC sublayer. The respective RLC entity operates in Unacknowledged mode (UM). This model assumes that there is a function in the RNC above BMC that resolves the geographical area information of the CBC message (or, if applicable, performs evaluation of a cell list) received from the Cell Broadcast Centre (CBC). A BMC protocol entity serves only those messages at BMC-SAP that are to be broadcast into a specified cell.

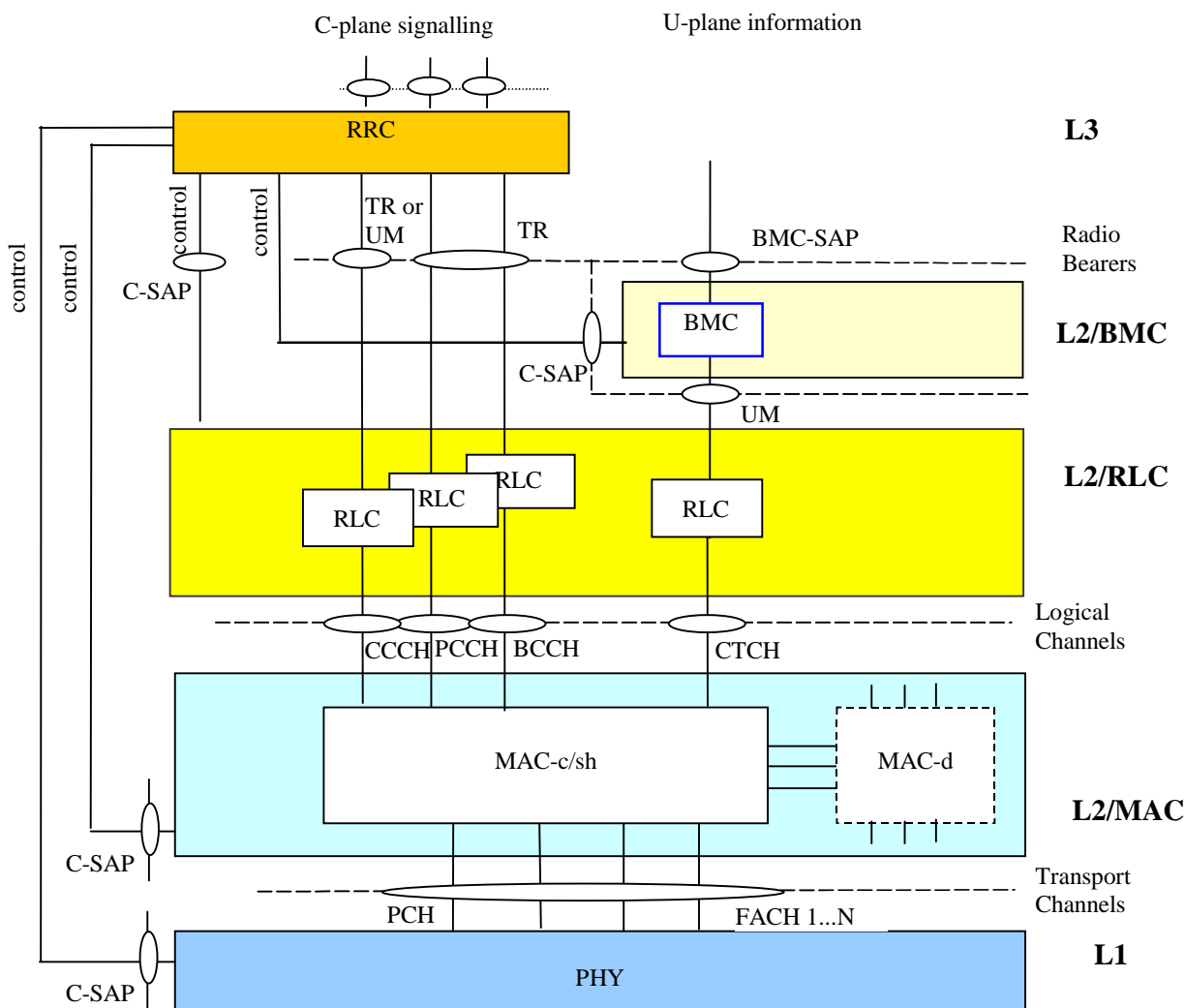

Figure 6.3: Protocol architecture on the radio interface

The following assumptions are made:

- For each cell that supports CBS, one BMC entity should be created in CRNC.
- In the UE one BMC entity should be created when the user has activated CB message IDs.
- It is assumed that one CTCH is created per broadcast/multicast service.

NOTE: For R99 only one CTCH is necessary because only CBS is part of this release.

- The logical channel types BCCH, CCCH, SHCCH (TDD), CTCH, DCCH and DTCH can be mapped onto a FACH.
- A constant TB size is assumed and hence a CTCH should be mapped onto a single FACH.
- CB messages delivered by CBC arrive in BMC as a single packet (BMC SDU (cf. 3GPP TS 23.041)).
- For R99 UEs can have the capability to receive CB messages in Idle mode and in Connected mode.
- CB messages are user data delivered in the user plane to BMC.
- Common traffic radio bearer of a cell is established, maintained and released by RRC.
- The RRC (CRNC) configures the CBS related channels via the control SAPs and signals availability of CBS to the peer RRC (UE) via System Information Message which itself configures its lower layers.
- The BMC (CRNC) stores the CB messages arriving over the CBC-RNC-interface and generates the BMC Message sequences.
- Scheduling and DRX procedure:  
There are fixed, periodic allocations for CTCH data on FACH and S-CCPCH. This information is conveyed by RRC (CRNC) via System Information Message on BCCH. The receiving BMC (UE) detects and reads the BMC Schedule Message. Based on its stored schedule information, the BMC (UE) can decide which CB message is new or old. RRC (UE) is informed to instruct the PHY (UE) via C-PHY when it has to listen to the physical channel(s) carrying CBS information.

## 6.3.2 Examples of procedures

NOTE: The examples provided in the following subclauses are based on the GSM CBS. For ANSI-41 CBS, similar examples can be derived.

Following examples of procedures are described in this subclause:

- CB message storage in BMC entity and counting of CB message repetition (subclause 6.2.2.1);
- BMC message scheduling (including CBS related radio resource configuration and system information broadcast) (subclause 6.2.2.2);
- Activation of CB message reception in the UE by the User (subclause 6.2.2.3);
- CB message reception with CB DRX (subclause 6.2.2.4);
- BMC Overflow (subclause 6.2.2.5);
- BMC Underflow (subclause 6.2.2.6).

### 6.3.2.1 CB message storage in BMC entity and counting of CB message repetition

Precondition:

A BMC entity on the network side serving a specific cell is created by O&M when CBS support is activated for this cell.

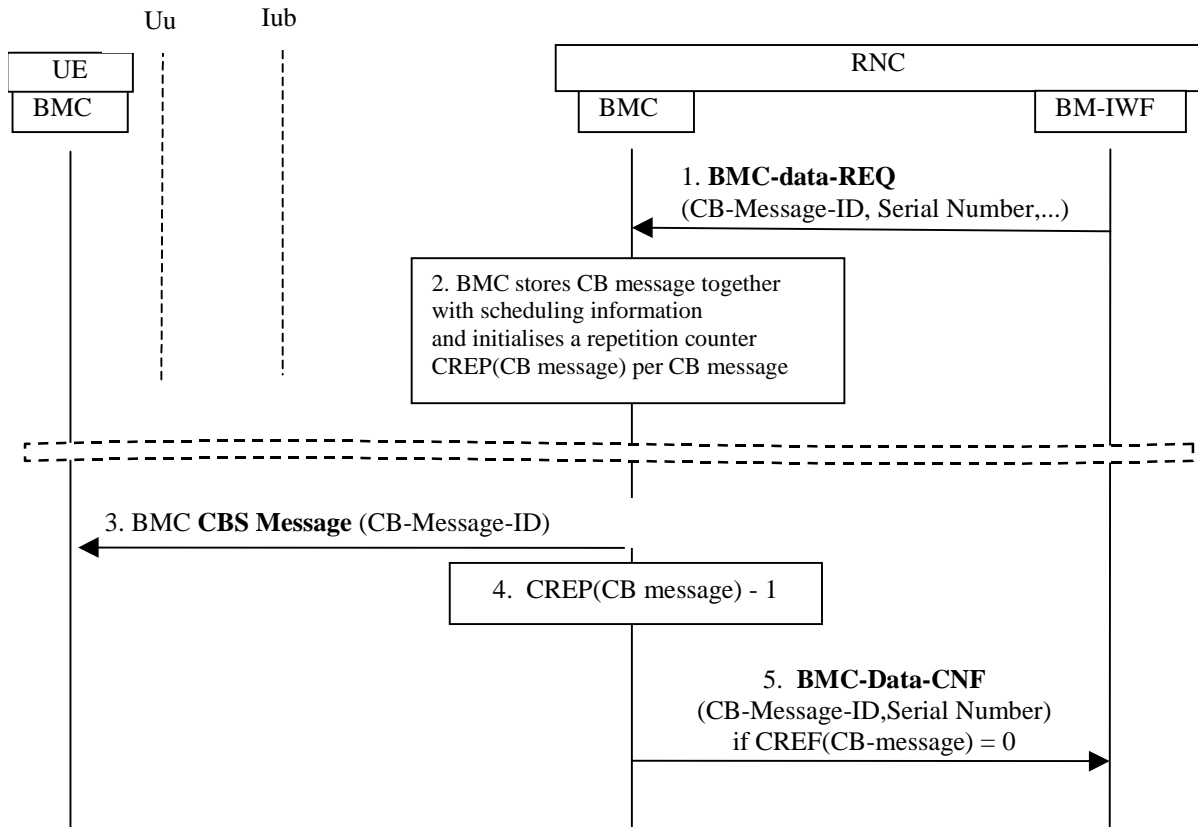

**Figure 6.4: Example of Message Flow for broadcast of CBS related system information**

The example message sequence for broadcast of CBS related system information is described as follows (numbering refers to message numbering in the figure, parameters given in square brackets are optional):

1. BMC receives the CB message together with scheduling information from CBC:  
BMC-Data-REQ (CB message, Schedule information) with

CB message:

Message-ID,  
[Old-Serial-Number],  
New-Serial-Number,  
Data-Coding-Scheme,  
CB-Data

Scheduling information:

[Category],  
Repetition-Period,  
Number-of-Broadcasts-Requested

NOTE: For R99 the CB-Data equals to the term CB message which is introduced in subclause 6.1.1.

The description of the listed parameters is given in TS 23.041 [13].



2. BMC stores the CB message and the Scheduling information.

This is necessary because it is only received once but have to be transmitted n times over the radio interface, where n = Number-of-Broadcasts-Requested.

For each CB message a repetition counter CREP is created if Number of Broadcast Requested is finite.

A CB message is completely identified by the pair (Message-ID, Serial-Number).

If the primitive do not contain the Old-Serial-Number parameter it should be the first time this CB message is delivered. If this is not the case, an error indication BMC-Error-IND(Cause=Message ID already stored) should be given to the BM-IWF.

If the primitive contains the Old-Serial-Number parameter an existing CB-Message should be replaced. If the indicated old CB message is not stored an error indication BMC-Error-IND(Cause=old CB message not stored) should be given but the delivered CB message should be stored and handled as a new CB message.

**Table 6.2: Mapping between Primitive parameters and BMC PDU information elements**

Parameter of BMC-Data-REQ (TS 25.324 [16]))	Information element of BMC CBS Message (TS 25.324 [16]))	Parameter of BMC-Data-IND (TS 25.324 [16]))
Message-ID	Message ID	Message-ID
[Old-Serial-Number]	---	not applicable
New-Serial-Number	Serial Number	Serial Number
Data-Coding-Scheme	Data Coding Scheme	Data Coding Scheme
CB-Data	CB Data	CB-Data

- 3-5. The CREP(CB-Message-ID) is decreased each time this CB message is broadcast. When CREP(Message-ID) equals 0 an indication BMC-Data-CNF(Message-ID) is given to BM-IWF that the task is finished.

6.3.2.2 BMC message scheduling

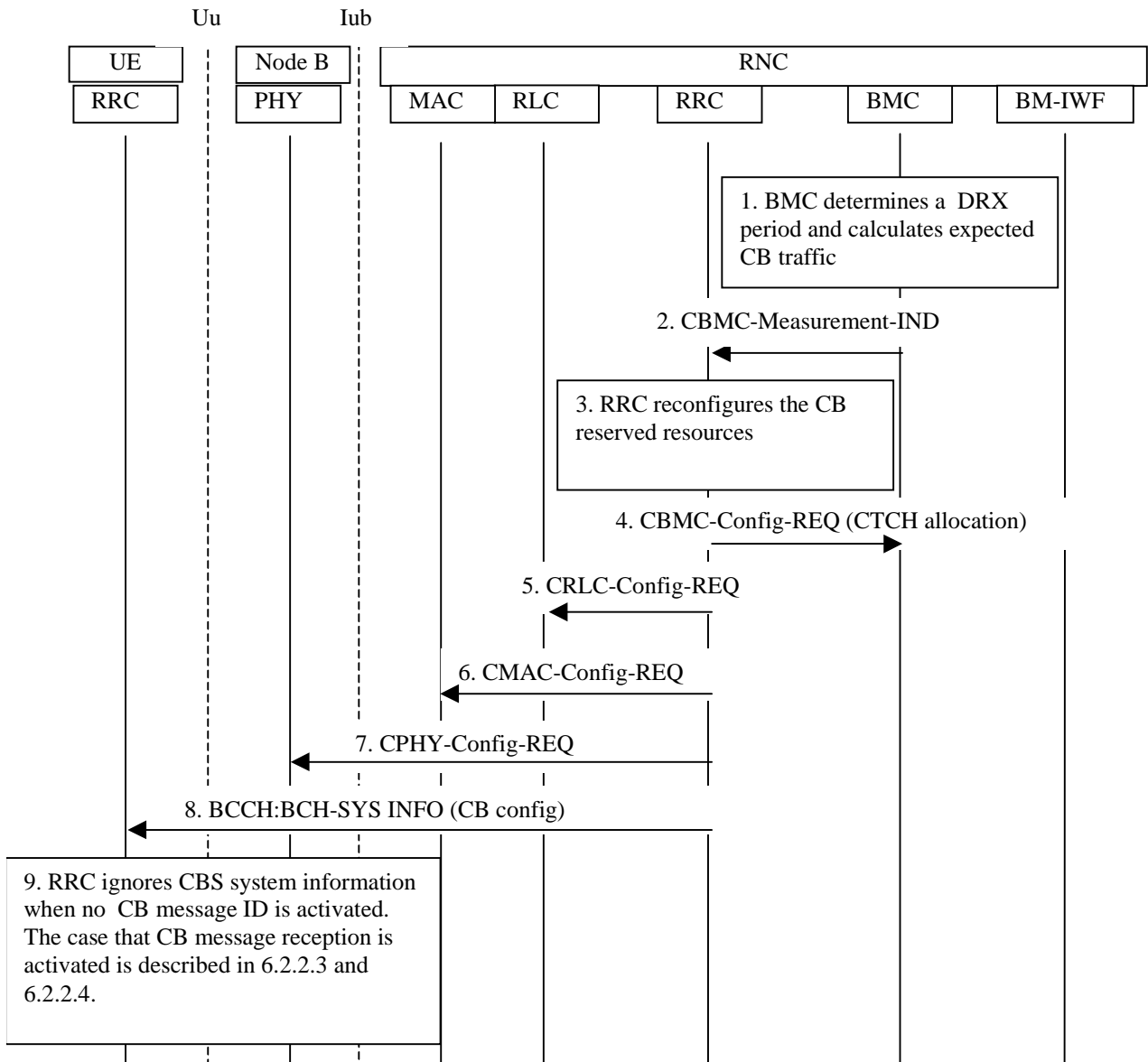

Figure 6.5: Example of Message Flow for BMC message scheduling

The example sequence for BMC message scheduling is described as follows (numbering refers to message numbering in the figure):

1. BMC calculates periodically a CBS DRX period. If CBC has assigned a DRX period to the message this information shall be taken into account by the scheduling scheme.  
BMC schedules continuously the CB message sequence which has to be transmitted during the current and next scheduling period. A result of the schedule calculations performed in BMC is the overall CB traffic volume.

When BMC is requested to send a CB message, the following scenarios may occur:

- Case 1: It is the first time that a CB message is sent in a specific cell.
  - Case 2: Transmission of other CB messages is already activated.
    - Subcase 2.1: Within the current CBS DRX period reserved radio resources which are marked as "new" could be used to sent the CB message immediately.
    - Subcase 2.2: CB message could be sent the first time in the next CBS DRX period and the reserved CB capacity is enough.
    - Subcase 2.3: CB message could be sent the first time in the next CBS DRX period, but the currently reserved radio resource capacity is too low.
- 2, 3. For case 1 and subcase 2.3 the BMC indicates to RRC the CB traffic volume using the primitive CBMC-Measurement-IND. RRC checks whether more radio resources can be reserved for CTCH traffic. If possible, RRC reconfigures RLC, MAC and PHY at the network side and informs the peer RRC entities (see step 8). If not possible, the configuration remains as it is.
  4. RRC informs BMC about the successful/unsuccessful reconfiguration (acknowledgement on 2.) with the primitive CBMC-Config-REQ (CTCH configuration):
    - If RRC could not provide enough CB resources flow control mechanism should be initiated by BMC; primitive BMC-Congestion-IND is used to indicate to BM-IWF the congestion situation. For flow control see subclauses 6.3.2.5 and 6.3.2.6.
  5. RRC configures RLC (if necessary).
  6. RRC configures MAC (if necessary).
  7. RRC configures PHY (in Node B) (if necessary).
  8. The reconfiguration of CBS resource allocation is broadcast by SYSTEM INFORMATION message to the UE. The CBS related system information is carried by BCCH mapped to BCH. 9. If CB message reception is not activated by the UE, RRC ignores this system information. Otherwise the RRC configures its lower layers regarding the received configuration information. For details see 6.3.2.2 and 6.3.2.3.

6.3.2.3 Activation of CB message reception by User

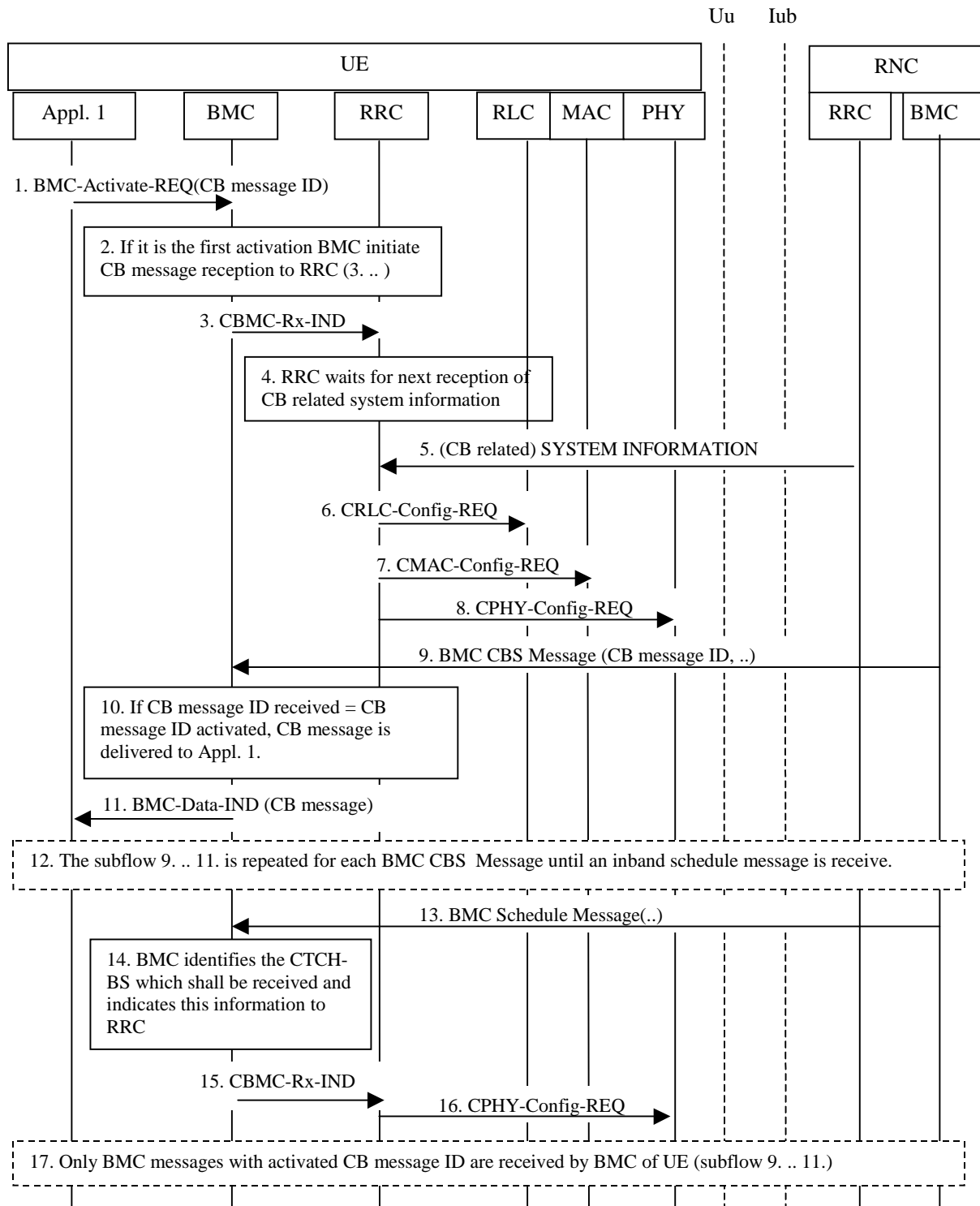

Figure 6.6: Example of Message Flow for activation of CB message reception by User

The example sequence for activation of CB message reception by the user is described as follows (numbering refers to message numbering in the figure):

1. The user activates a Message ID by the primitive BMC-Activation-REQ.

(It is assumed that a BMC entity is already established).

NOTE: This primitive is not yet defined by T WG 2 SWG 3.

- 2, 3. If it is the first time the user activates a Message ID the BMC shall indicate to RRC that CB message reception shall start. This is done by primitive CBMC-Rx-IND.
- 4, 5. When RRC receives such an indication first it has to wait for the next CB related SYSTEM INFORMATION message to read the general CB configuration.
- 6...8. The RRC configures the CBS related radio resources.
- 9...13. All BMC messages are read by BMC until a first BMC Schedule message is received. A BMC CBS Message consists of the IEs Message ID, Serial Number, Data Coding System and CB Data. The received CB messages are only delivered by the primitive BMC-Data-IND to the CB application if the received Message ID and/or the received Serial Number are new. The BMC messages are described in TS 25.324 [16].
- 14, 15. The BMC Schedule message informs which CB messages will be sent when in the next DRX schedule period. The BMC indicates to the RRC only those BMC messages which should be received by the UE (CBMC-Rx-IND). The decision which BMC messages are of interest is based on the activated Message IDs and the comparison of the Serial Number received with which that is currently stored in the UE.
16. The RRC configures the PHY layer at which time intervals it should receive on the CBS related radio resources.
17. As an consequence only CB messages of interest are received by the BMC of the UE and delivered to the CB application.

#### 6.3.2.4 CB message reception with DRX

Precondition:

Under normal condition BMC Schedule messages are received each time when they are sent. When a BMC Schedule Message is corrupted the BMC should read all BMC messages continuously until a new BMC Schedule Message is found.

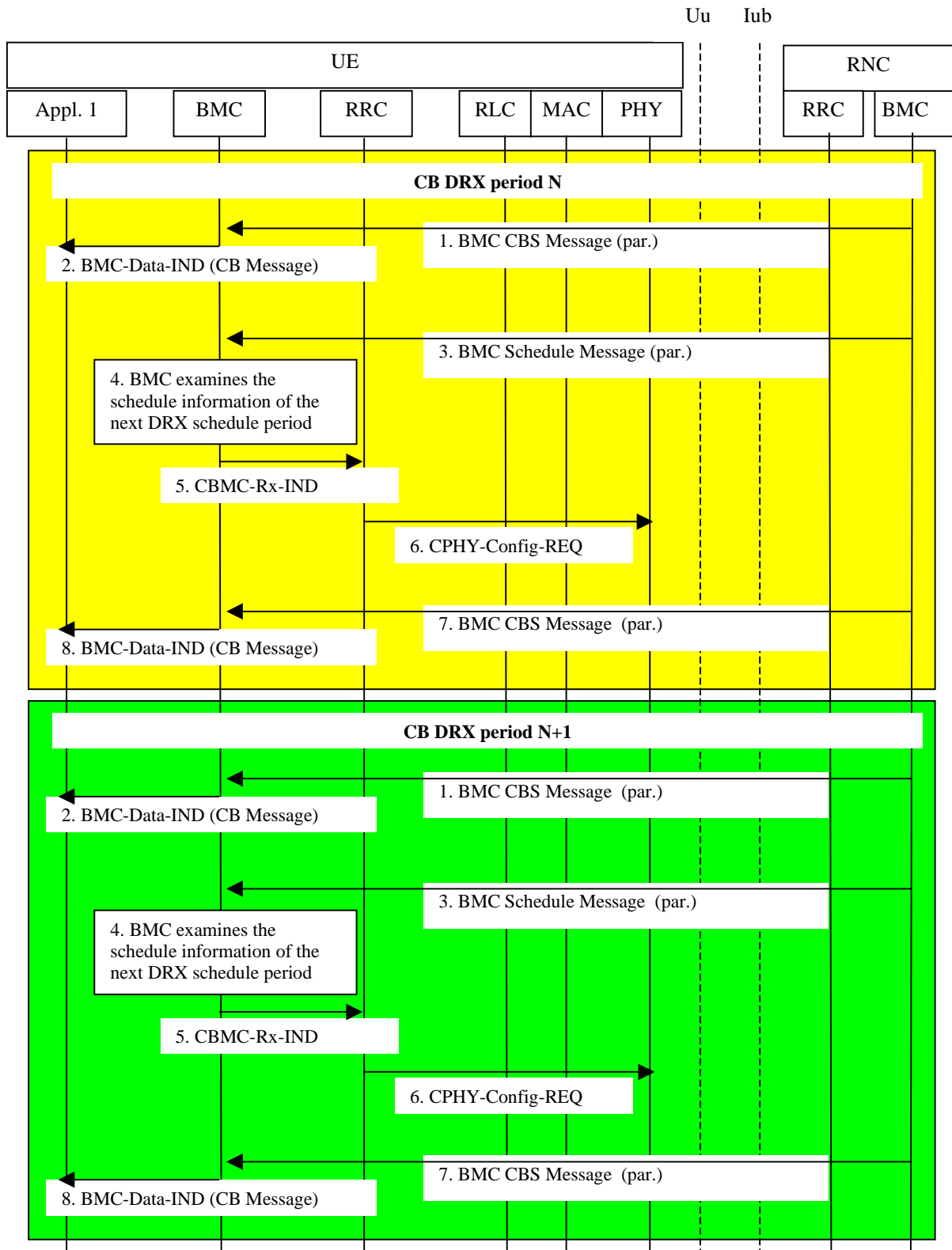

Figure 6.7: Example of Message Flow for CB message reception with DRX

The example sequence for CB message reception with DRX is described as follows (numbering refers to message numbering in the figure):

- 1, 2. UE receives only those BMC messages for which reception is configured. The BMC should still check whether a CB message contained in a BMC message should be indicated to upper layer or not. A CB message is indicated to upper layer, if it is the first time a CB message with an activated Message ID is received or if the CB message is already received but the Serial Number has changed.
- 3...6. The reception of BMC Schedule messages is always configured by the UE when CB message reception is activated (see 6.3.2.3). The BMC evaluates the BMC Schedule message and indicates to RRC at which time intervals of the next DRX period the BMC CBS message reception should be configured (primitive CBMC-Rx-IND). The RRC configures upon this information the PHY layer (primitive CPHY-Config-REQ).
- 7, 8. The BMC Schedule message is not the last one within the CB DRX period; other CBS Messages may follow.

### 6.3.2.5 Overflow

Precondition: The BMC periodically performs calculation of the CBS schedule period.

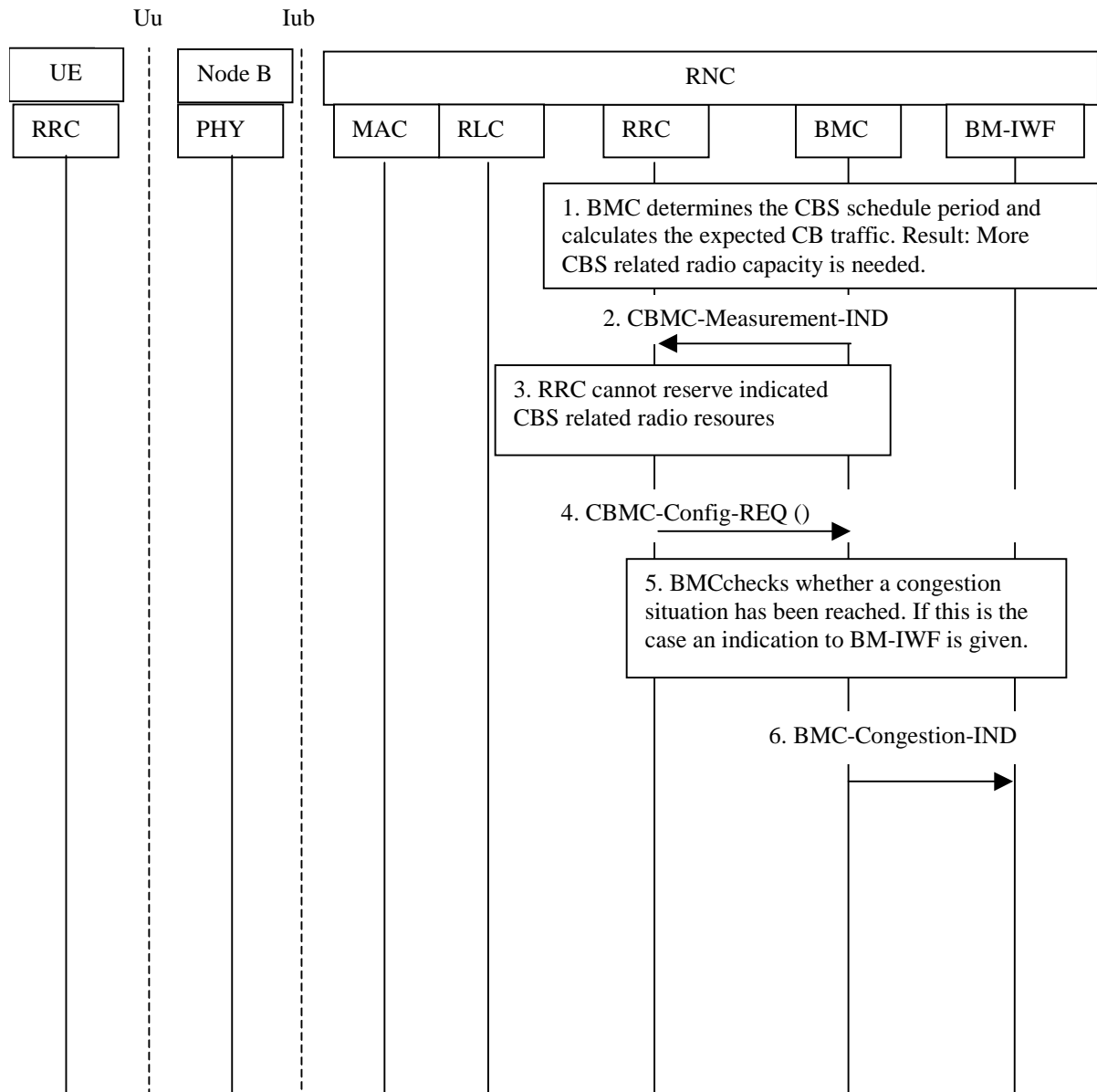

Figure 6.8: Example of Message Flow for Overflow

The example message sequence for the case of overflow is described as follows (numbering refers to message numbering in the figure):

1,2. If more capacity is required, an indication is given to RRC with CBMC-Measurement-IND.

3...6. The decision when a BMC is congested is implementation dependent. A congestion situation is indicated to BM-IWF by BMC-Congestion-IND each time the BMC calculates the CBS schedule period and the congestion situation has not resolved.

Each time the BMC determines the CBS schedule period an BMC-Congestion-IND is sent to BM-IWF until the RRC can provide enough capacity or the CB traffic volume reduces so that the allocated capacity is enough.

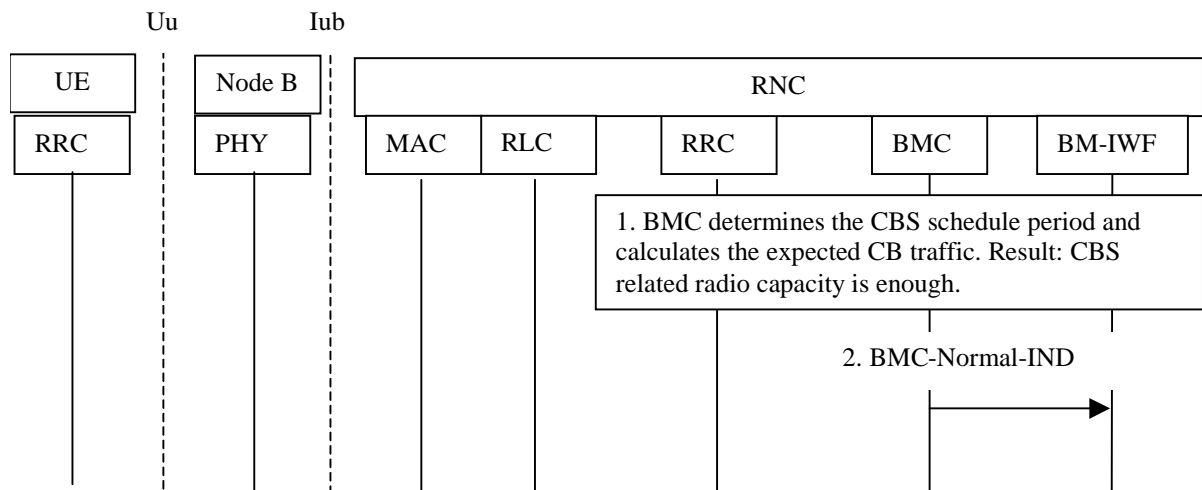
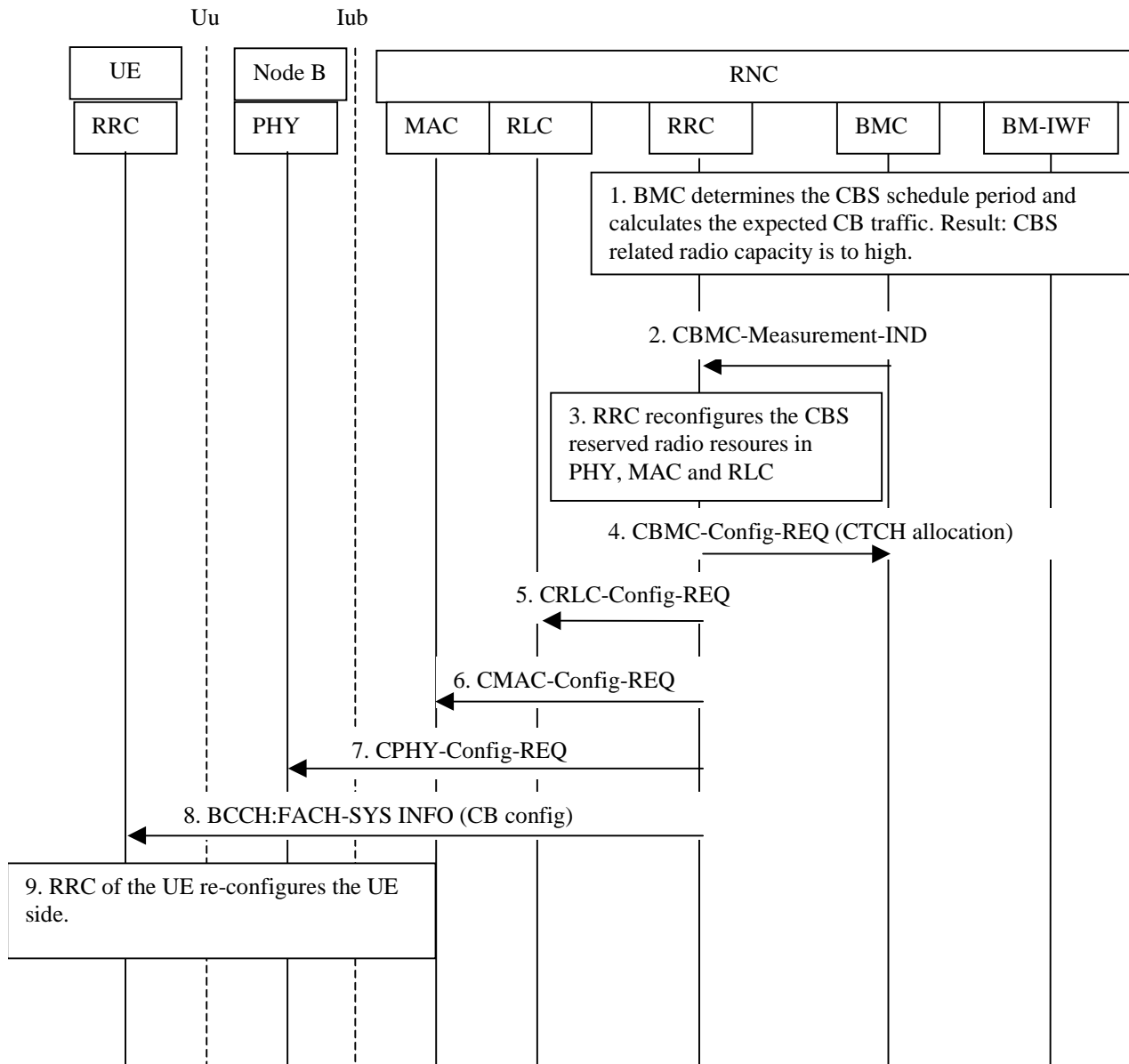

Figure 6.9: Example for Message Flow for Recovery from Overflow

### 6.3.2.6 Underflow

Precondition: The BMC periodically performs calculation of the CBS schedule period.





**Figure 6.10: Example of Message Flow for Underflow**

The example message sequence for the case of underflow is described as follows (numbering refers to message numbering in the figure):

- 1,2. If less capacity is required an indication is given to RRC with CBMC-Measurement-IND.
- 3...9. The RRC confirms by CBMC-Config-REQ and configures the other lower layers. It is recommended that such reconfigurations should not occur often because each time it is performed this modification needs to be indicated as change of system information.

### 6.3.3 UE capabilities with respect to CBS

A UE supporting Cell Broadcast Service (CBS) shall be capable to receive BMC messages in the Idle mode and in CELL\_PCH and URA\_PCH RRC-states of Connected mode.

## 6.3.4 CBS allocated radio resources

The TrCH type FACH is chosen for Release 1999. A CTCH is mapped onto one FACH which is mapped onto one S-CCPCH.

Detailed information regarding mapping of logical channels and multiplexing in MAC and PHY can be found in TS 25.302 [5] and TS 25.321 [8].

## 6.3.5 Impact on RRC

### 6.3.5.1 RRC Functions

RRC (in the CRNC) shall perform the following functions at the UTRAN side:

- Initial configuration of BMC sublayer;
- Configuration of RLC, MAC and PHY for CBS;
- Indication of MAC/PHY configuration to BMC to enable generation of inband scheduling message;
- Broadcast of CBS related system information (allocation of CTCH data on FACH/S-CCPCH).

RRC shall perform the following functions at the UE side:

- Reception of CBS related system information on BCCH;
- Initial configuration of a BMC entity (on request from higher layer);
- Configuration of RLC, MAC and PHY for CBS in DRX mode.

### 6.3.5.2 CB related system information

Whether CB transmission capability is available or not and the configuration of the CB resources should be broadcast as system information. The RRC of the UE configures its local resources upon the received CB-related system information.

The CB related system information is:

- Identifier in MIB to SIB that contains CB related system information;
- CB related system information of the CBS related SIB:
  - CTCH identification;
  - FACH identification and associated transport format set;
  - S-CCPCH identification;
  - CBS DRX Level 1 information:
    - Period of CTCH allocation on S-CCPCH;
    - CBS frame offset.

A description of these Information Elements is given in subclause 6.3.6.2 and in 3GPP TS 25.324 [16].

## 6.3.6 Impact on BMC

### 6.3.6.1 R99-requirements:

The length of one cell broadcast message shall be the same as defined for GSM:  
 $\leq 1246$  octets (cf. 3GPP TS 23.041 [13]).

### 6.3.6.2 BMC Functions

BMC shall perform the following functions at the UTRAN side:

- Storage of CBS messages;
- CBS "traffic volume monitoring" and request for CTCH/FACH resources from RRC;
- Generation of inband scheduling messages to enable discontinuous reception (DRX);
- Transmission of CBS messages to UE (including scheduling and repetition).

BMC shall perform the following functions at the UE side:

- Evaluation of CTCH inband scheduling message;
- Indication of inband scheduling parameters to RRC;
- Storage of Message ID and Serial Number of received CB Messages;
- Delivery of CBS messages to upper layer.

BMC procedures and messages are described in TS 25.324 [16].

### 6.3.6.3 BMC Message Scheduling

Figure 6.10 describes the principle of BMC message scheduling. CB messages together with schedule information is delivered by CBC via the BM-IWF distribution function. In addition, DRX information may be supplied. If no such DRX information is supplied the BMC entity calculates DRX information independently.

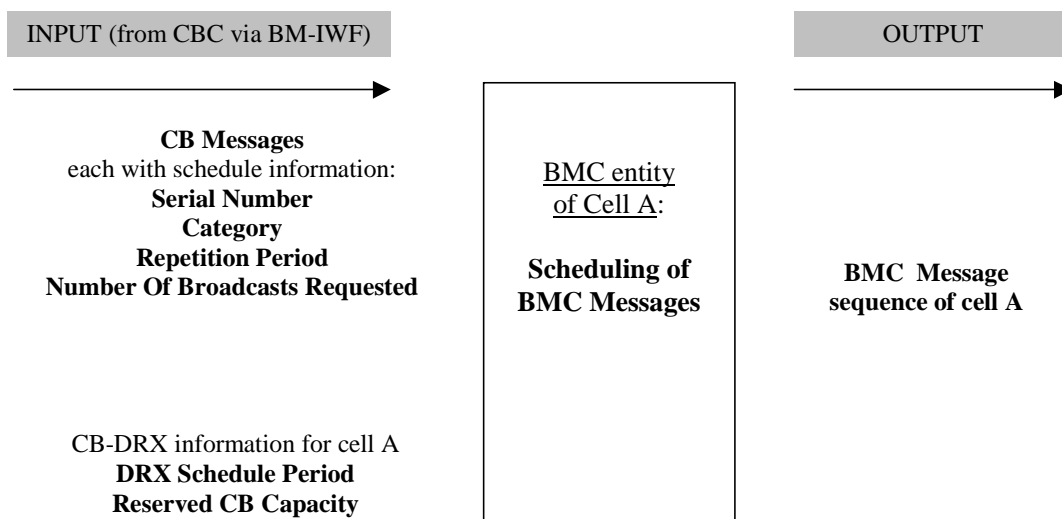

**Figure 6.11: RNC-function: Schedule of CB messages**

#### 6.3.6.4 CBS Discontinuous Reception (DRX)

The overall scheduling information is divided into two parts, which can be interpreted as two levels of scheduling. The lower level ("Level 2") is referred to as "inband scheduling message". The inband scheduling message is sent on the CTCH together with the actual CB messages (as in CBS-GSM). The higher-level ("Level 1") scheduling information shall indicate in which Transmission Time Interval (TTI) of an FACH and correspondingly in which radio frame of the S-CCPCH, cell broadcast data can be found, i.e. the time intervals where transmission capacity is allocated for the CTCH. This higher-level scheduling information shall be transmitted as part of the system information message on BCCH and shall also be received on the FACH.

Note that this concept assumes that there are fixed, periodic allocations for CTCH data on FACH and S-CCPCH. At these predefined allocations, CTCH data would have highest priority for transmission. It would however be allowed to fill these time intervals up with data from other logical channels if applicable and if more resources would be available than needed for CTCH (the resources would be defined in terms of TFC set). It is furthermore assumed that the CTCH allocations indicated to UEs by the higher-level scheduling information will change only very slowly (i.e. at a much slower rate than the DRX scheduling period for CTCH). Changes of this scheduling information could therefore be indicated with "normal" procedures foreseen to indicate modification of system information parameters, e.g. with "Paging Type 1" message.

Note that the concept of priority control with respect to cell broadcast data is basically identical with the one required for handling of paging information. Resource allocations for paging and CBS data have to respect each other and should therefore be performed jointly anyway. The additional complexity for MAC-c due to CBS should be rather low.

In the Layer 1 different Transport Channels can be mapped onto the same S-CCPCH resources, e.g. a PCH channel and a FACH which carries CTCH data. If the physical channel capacity is not large enough to carry all channels at the same time, a prioritization takes place in the MAC between the logical data streams. When configuring the Transport Channels on S-CCPCH, it is beneficial for the performance of CBS if PCCH and CTCH data, for which DRX is applied in the UE and which are both scheduled to specific radio frames, do not compete for the same radio resources. This can for example be achieved by assigning a transmission rate for S-CCPCH that can transmit both channels at the same time. In TDD, it is also possible to configure the PCH and the CTCH data on FACH on distinct radio frames.

For allowing UE to receive the CB messages in CBS DRX mode, it is necessary to inform the UE when individual CB messages are transmitted in a cell. For that purpose, a Schedule message is proposed similar as in GSM, which is adapted to the UMTS radio interface. The complete reading of a Schedule message allows the UE to enter DRX mode. When the UE reads the Schedule message, it receives information which message is of interest and where it is located during the schedule period. If there are CB messages during the schedule period which are of interest to the UE, UE reads those frames which are indicated by the Schedule message.

UEs that support CBS, shall also support both levels of scheduling for Release 99.

##### 6.3.6.4.1 Level 1 scheduling: Scheduling on FACH regarding logical channel CTCH

The Level 2 scheduling requires that certain radio frame intervals [SFN=k, SFN=l] are known on L1 where CB messages could be transmitted. The length of these intervals is given by  $TTI/10$  ms, where TTI is the transmission time interval of the FACH carrying the CTCH. Remember that for R99 only one CTCH is created and this CTCH is mapped to only one FACH with fixed TB size and fixed TTI.

The Level 1 scheduling can be dynamic or static. Static means that the CTCH is mapped on a regular basis, dynamic means that it varies over the time. In Release 99 only a static method is required. An algorithm to determine the CTCH allocated radio resources can be defined as follows:

- $M_{TTI}$ : number of radio frames in the TTI of the FACH used for CTCH.
- N: period of CTCH allocation on S-CCPCH, integer number of radio frames,  
 $M_{TTI} \leq N \leq \text{MaxSFN} - K$ , where N is a multiple of  $M_{TTI}$  (cf. TS 25.212 and TS 25.222).
- MaxSFN: maximum system frame number = 4096 (cf. TS 25.402 [18]).
- K: CBS frame offset, integer number of radio frames  $0 \leq K \leq N-1$  where K is a multiple of  $M_{TTI}$ .

When no CTCH traffic is broadcast, this can be indicated with  $N := 0$ .

N and K shall be broadcast as system information (cf. subclause 6.2.5.1).

Example:  $N = 6, K = 2, M_{TTI} = 2$

On the S-CCPCH the TTIs allocated for CTCH transmission are periodically repeated with period  $N$ . The first CTCH allocated TTI within each SFN cycle [ 0 .. MaxSFN-1 ] is positioned with an offset  $K$ .

0	1	2	3	4	5	6	7	8	9	10	11	12	13	14	15	16	17
		CTCH	CTCH					CTCH	CTCH					CTCH	CTCH		

**Figure 6.12: Example of CBS DRX cycle**

6.3.6.4.2 Level 2 scheduling: DRX on CTCH content

The Level 2 scheduling method follows the method specified for GSM in 3GPP TS 23.041 [13] and 3GPP TS 24.012 [17]. A DRX Schedule Period and a Reserved CB Capacity may be commanded by an O&M system. Thus, two cases shall be covered described below as case 1 and case 2, where the O&M system *has not* or *has* requested a CB-DRX schedule period and/or Reserved CB Capacity, respectively.

In the following, a set of CTCH MAC SDUs (RLC PDUs) is denoted as CTCH Block Set (CTCH-BS), which comprises all or a part of a single BMC message and satisfies the requirement that, in terms of block size and block number, it will fit into a single TTI of the FACH it is mapped to. If in a particular TTI the CTCH is the only channel that is mapped to a FACH, then a CTCH Block Set corresponds to FACH Transport Block Set. A CTCH Block Set may consist of a variable number of CTCH MAC SDUs of a fixed length. A CTCH Block Set shall be transmitted entirely in a single FACH TTI, independent on whether MAC multiplexing with other logical channels is performed or not.

A CBS schedule period can then be defined as a sequence of CTCH Block Sets. Thus defined CBS schedule period may have a variable length, i.e. comprise a variable number of CBS Block Sets.

A BMC message shall be comprised of  $n \geq 1$  CTCH Block Sets and shall be transmitted completely within the CBS schedule period. If the FACH transport format permits that more transport blocks than needed for CTCH can be transmitted in one TTI allocated for CTCH these transport blocks can be used for other logical channels.

A CTCH-BS indexing scheme  $I = \{1,2,...,256\}$  is chosen on which the CBS schedule periods can be mapped. This scheme is repeated cyclically. The CTCH-BS index 1 of the first cycle refers to the first occasion of CTCH-BS after CTCH creation.

Example:

With the values from above ( $N = 6, K = 2, M_{TTI} = 2$ ) following mapping between CTCH-BS index and SFNs may be given:

Absolute CTCH-BS index	SFN	Absolute CTCH-BS index	SFN
1	2,3	13	74,75
2	8,9	14	80,81
3	14,15	15	86,87
4	20,21	16	92,93
5	26,27	...	...
6	32,33		
7	38,39		
8	46,45		
9	50,51		
10	56,57		
11	62,63		
12	68,69		

**Figure 6.13: Example of CTCH BS index mapping on SFNs**

6.3.6.4.2.1 Case 1: O&M system has not requested CB-DRX schedule period

The CBS Schedule period could be chosen by BMC based on the schedule information of the stored CB messages and the current value of the repetition counters configured per CB message. For each CBS Schedule Period a BMC Schedule Message is generated and transmitted inband on the CTCH. The format is as follows:

8	7	6	5	4	3	2	1	Octet:
Message Type (= 0000 0010'B)								1
Offset to Begin CTCH-BS Index								2
Length of CBS Scheduling Period								3
New Message Bitmap								4 - n
Message Descriptions								(n+1) - m

**Figure 6.14: BMC Schedule Message coding**

**Offset to Begin CTCH-BS Index:**

Offset relative to the CTCH-BS index of the BMC Schedule Message pointing to the first CTCH-BS index of the next CBS schedule period. The Offset to Begin CBS Index field is coded in binary. Value range: 1 to 255.

**Length of CBS Scheduling Period:**

Length of CBS Scheduling period is the number of consecutive CTCH-BS of the next schedule period. Together with Offset to Begin CTCH-BS Index it points to the end of the CBS schedule period. The Length of CBS Scheduling Period field shall be coded in binary, Value range: 1 to 256.

**New CBS Message Bitmap**

CTCH-BS index <i>B</i>	CTCH-BS index <i>B</i> +1	CTCH-BS index <i>B</i> +2	...					Octet
								1
								2
								...
	...	CTCH-BS index <i>E</i> -1	CTCH-BS index <i>E</i>	0	0	0	0	N

Legend: *B* CTCH-BS index of the begin CTCH-BS of the CBS schedule period  
*E* CTCH-BS index of the end CTCH-BS of the CBS schedule period,  $E = B + \text{Length of CBS Schedule Period} - 1$   
*n* number of octets necessary to transmit the bitmap

**Figure 6.15: New CBS Message Bitmap coding**

**CTCH-BS Index *i*:**

Bit *i* of the New CBS Message Bitmap refers to the content of CTCH-BS index *i*,  $i=B, \dots, E$ . Its meaning is as follows:

- 1 The CTCH-BS contains possibly partly a BMC Message which was either not sent during the previous CBS schedule period, or sent unscheduled during the preceding CBS schedule period; or, the CTCH-BS is indicated as of free usage, reading advised, or it contains the Schedule Message partly or complete of the following CBS schedule period.

The value is 1 both for the first transmission of a BMC message in the CBS schedule period or a repetition of it within the CBS schedule period.

- 0 The CTCH-BS is such that value 1 is not suitable. If Length of CBS Schedule Period is not a multiple of 8 the remaining bit positions are padded with "0".

A BMC message fulfilling the criterion for bit value 1 is said in the following to be "new". It should be noted that broadcasting of such a message is not necessarily the first one. The network can choose not to send a given BMC message in all schedule periods. In this case it will be "new" each time it has not been sent in the previous schedule period. Another case is when a BMC message is scheduled but its first transmission in the schedule period is pre-empted; the next time the BMC message is "new".

**Message Description**

This part contains as many Message Descriptions as there are bits except the padding bits in the New Message Bitmap.

All descriptions pertaining to the first transmission of a new message shall be put at the beginning, so that mobile stations can determine rapidly where the new messages are.

The CTCH-BS Index for each description must be derived from the New Message Bitmap.

Example:

For a UE which starts reception on CTCH, the first Schedule Message is unscheduled. A Schedule Message conveys the information about message identifiers, the location of newly updated CB messages, and the location of the next Schedule message.

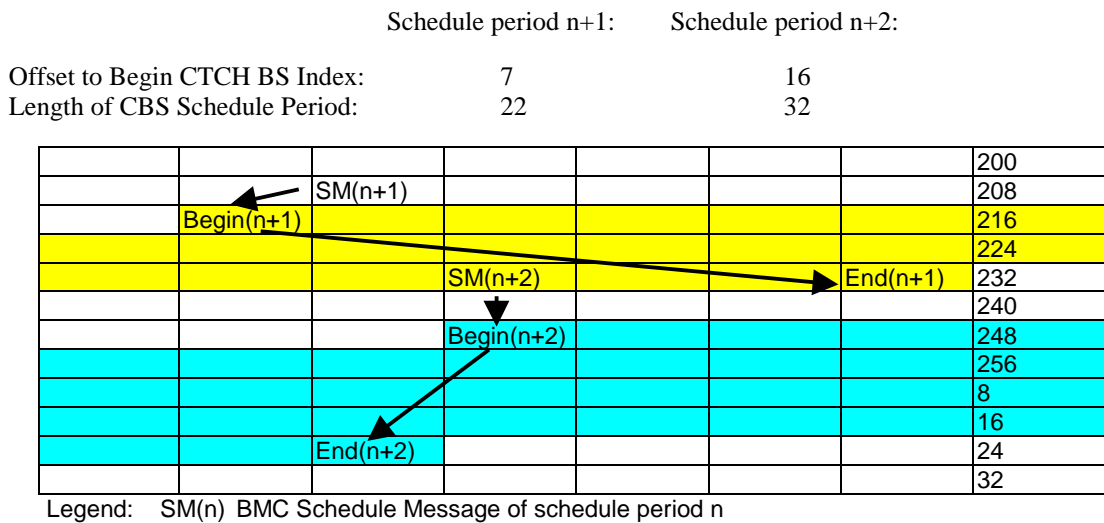

**Figure 6.16: Example of CBS Schedule Periods**

6.3.6.4.2.2 Case 2: O&M system has requested a CB-DRX schedule period

The CBS Schedule Period and the Reserved CB Capacity is commanded by an O&M system via the BM-IWF. In this case BMC shall use these parameter values for CBS scheduling. This implies a CBS Schedule Period of fixed size. All other procedures are the same as in Case 1.

**6.3.7 Impact on RLC**

The Unacknowledged Mode RLC service is employed.

**6.3.7.1 RLC Functions**

RLC shall perform the following functions at the UTRAN side:

- Segmentation of BMC Messages into Transport Blocks:
 

The RLC receives BMC Messages (CBS or Schedule Messages) with RLC-Data-REQ, segments it if appropriate and delivers it to MAC via the CTCH SAP. The segmentation depends on the configured resources.

RLC shall perform the following functions at the UE side:

- Reassembly of Transport Blocks into BMC Messages.

## 6.3.8 Impact on MAC

### 6.3.8.1 MAC Functions

MAC shall perform the following functions at the UTRAN side:

- Multiplexing of CTCH with other logical channels (CCCH, BCCH, and SHCCH for TDD) and mapping onto a FACH (one or several, depending on MAC SDU size for CTCH. Design goal should be to define a SDU size for CTCH which results in a transport block size that is used also on other channels when mapped onto FACH. For Release '99 a single TB size should be sufficient).
- Priority control and TFCI selection (for all transport channels, FACHs and PCH, controlled by MAC-c).

MAC shall perform the following functions at the UE side:

- Demultiplexing of CTCH and other logical channels at TTIs defined by DRX scheduling information.

## 6.3.9 Other items

### 6.3.9.1 CBS Compression

The CBS compression is applied on user information transmitted from CBC to UE. With the decision to broadcast a BMC message as one unit CBS compression has no impact on the radio interface.

More information is provided in 3GPP TS 23.041 [13]. Detailed requirements are not available.

### 6.3.9.2 CBS Index

The CBS Index is a CB message on the Application layer between CBC and UE. It is broadcast as a "normal" CB message with the exception that it is always a "new" message with optional reading.

More information is provided in 3GPP TS 23.041 [13]. Detailed requirements are not available.

---

## 7 PTM-Multicast Service (GPRS)

This clause contains the requirements derived from GPRS specifications of Point-to-multipoint Multicast service and the analysis regarding the UMTS radio interface Uu.

NOTE: The GPRS PTM-Multicast service is not part of Release 1999.

---

## 8 PTM-Group Call Service (GPRS)

This clause contains the requirements derived from GPRS specifications of Point-to-multipoint Group Call service and the analysis regarding the UMTS radio interface Uu.

NOTE: The GPRS PTM-Group Call service is not part of Release 1999.

---

## 9 IP Multicast Service (GPRS)

This clause contains the requirements derived from GPRS specifications of IP Multicast service and the analysis regarding the UMTS radio interface Uu.

NOTE: The GPRS IP-Multicast service is not part of Release 1999.



---

## 10 Multimedia Distribution Service (UMTS)

This chapter contains the requirements derived from UMTS Technical Specifications and the analysis regarding the radio interface Uu.

NOTE: The UMTS Multimedia Distribution Service is not part of Release 1999.

---

## Annex A: Functions related to MDS (ffs.)

Previous WG2 Input documents: R2-99075 (LGIC), R2-99076 (LGIC), R2-99218 (LGIC), R2-99219 (LGIC).

Input documents not presented yet: R2-99077 (LGIC).

Related WG2 Output documents: R2-99189 (TSG RAN WG2) LS to SA WG1 and SA WG2 on Multicast.

NOTE: The following text is taken from R2-99075 and should give a first overview of functions which should be analysed for MDS. Already made decisions are incorporated.

Functions which should be analysed are listed below:

### **RRC functions:**

*Variable Rate Support*

*Dynamic Code usage*

*Dynamic Scheduling*

*QoS Support (e.g. repetition time)*

(LGIC, R2-99075, for information)

### **RLC functions:**

*Unacknowledged multicast data transfer*

*Multicast Delivery*

(LGIC, R2-99075, for information)

### **MAC functions:**

*Support of multiple CTCH*

*Mapping and multiplexing/demultiplexing between CTCH and transport channels*

*Scheduling among CTCH*

*Support of dynamic rate change using TFCS*

(LGIC, R2-99075, for information)

New types of transport channels are not required.

### **L1 functions:**

*Transmission of messages containing multicast data to specific groups of UEs. This service includes provision of the location function necessary to deliver multicast messages to a mobile, which is in idle or slotted mode.*

*DTX (discontinuous transmission)*

*DRX (discontinuous reception)*

*Support of multicast data transmission with multi-code*

(LGIC, R2-99075, for information)

---

## Annex B: Change history

Change history							
Date	TSG #	TSG Doc.	CR	Rev	Subject/Comment	Old	New
12/99	RP-06	RP-99665	-		Approved at TSG-RAN #6 and placed under Change Control	-	3.0.0
03/00	RP-07	RP-000050	001		Miscellaneous corrections	3.0.0	3.1.0
	RP-07	RP-000050	002		Correction of RNC functions	3.0.0	3.1.0
09/00	RP-09	RP-000367	003		Corrections	3.1.0	3.2.0
12/00	RP-10	RP-000577	004	1	Correction to ANSI-41 Cell Broadcast Service	3.2.0	3.3.0

---

## History

<b>Document history</b>		
V3.0.0	January 2000	Publication
V3.1.0	March 2000	Publication
V3.2.0	September 2000	Publication
V3.3.0	December 2000	Publication