

Universal Mobile Telecommunications System (UMTS); Radio resource management strategies (3GPP TR 25.922 version 4.2.0 Release 4)



Reference

RTR/TSGR-0225922Uv4R2

Keywords

UMTS

ETSI

650 Route des Lucioles
F-06921 Sophia Antipolis Cedex - FRANCE

Tel.: +33 4 92 94 42 00 Fax: +33 4 93 65 47 16

Siret N° 348 623 562 00017 - NAF 742 C
Association à but non lucratif enregistrée à la
Sous-Préfecture de Grasse (06) N° 7803/88

Important notice

Individual copies of the present document can be downloaded from:

<http://www.etsi.org>

The present document may be made available in more than one electronic version or in print. In any case of existing or perceived difference in contents between such versions, the reference version is the Portable Document Format (PDF). In case of dispute, the reference shall be the printing on ETSI printers of the PDF version kept on a specific network drive within ETSI Secretariat.

Users of the present document should be aware that the document may be subject to revision or change of status. Information on the current status of this and other ETSI documents is available at

<http://portal.etsi.org/tb/status/status.asp>

If you find errors in the present document, send your comment to:

editor@etsi.fr

Copyright Notification

No part may be reproduced except as authorized by written permission.
The copyright and the foregoing restriction extend to reproduction in all media.

© European Telecommunications Standards Institute 2002.
All rights reserved.

DECTTM, **PLUGTESTS**TM and **UMTS**TM are Trade Marks of ETSI registered for the benefit of its Members.
TIPHONTM and the **TIPHON logo** are Trade Marks currently being registered by ETSI for the benefit of its Members.
3GPPTM is a Trade Mark of ETSI registered for the benefit of its Members and of the 3GPP Organizational Partners.

Intellectual Property Rights

IPRs essential or potentially essential to the present document may have been declared to ETSI. The information pertaining to these essential IPRs, if any, is publicly available for **ETSI members and non-members**, and can be found in ETSI SR 000 314: "*Intellectual Property Rights (IPRs); Essential, or potentially Essential, IPRs notified to ETSI in respect of ETSI standards*", which is available from the ETSI Secretariat. Latest updates are available on the ETSI Web server (<http://webapp.etsi.org/IPR/home.asp>).

Pursuant to the ETSI IPR Policy, no investigation, including IPR searches, has been carried out by ETSI. No guarantee can be given as to the existence of other IPRs not referenced in ETSI SR 000 314 (or the updates on the ETSI Web server) which are, or may be, or may become, essential to the present document.

Foreword

This Technical Report (TR) has been produced by ETSI 3rd Generation Partnership Project (3GPP).

The present document may refer to technical specifications or reports using their 3GPP identities, UMTS identities or GSM identities. These should be interpreted as being references to the corresponding ETSI deliverables.

The cross reference between GSM, UMTS, 3GPP and ETSI identities can be found under www.etsi.org/key.

Contents

Intellectual Property Rights	2
Foreword.....	2
Foreword.....	6
1 Scope	7
2 References	7
3 Definitions and abbreviations.....	8
3.1 Definitions	8
3.2 Abbreviations	8
4 Idle Mode Tasks	9
4.1 Overview	9
4.2 Service type in Idle mode	9
4.3 Criteria for Cell Selection and Reselection	10
4.3.1 Cell Selection.....	10
4.3.2 Cell Re-selection.....	10
4.3.2.1 Hierarchical Cell Structures	10
4.3.2.2 Measurements for cell re-selection	11
4.3.2.3 Cell re-selection criteria	11
4.3.3 Mapping of thresholds in cell reselection rules.....	11
4.3.4 Reserved cells	11
4.4 Location Registration	12
5 RRC Connection Mobility.....	12
5.1 Handover	12
5.1.1 Strategy	12
5.1.2 Causes	12
5.1.3 Hard Handover.....	13
5.1.4 Soft Handover	13
5.1.4.1 Soft Handover Parameters and Definitions	13
5.1.4.2 Example of a Soft Handover Algorithm.....	14
5.1.4.3 Soft Handover Execution	15
5.1.5 Inter Radio Access Technology Handover	16
5.1.5.1 Handover 3G to 2G	16
5.1.5.2 Handover 2G to 3G	16
5.1.5.2.1 Introduction	16
5.1.5.2.2 Predefined radio configuration information	16
5.1.5.2.2a Default configuration information.....	17
5.1.5.2.3 Security and UE capability information	17
5.1.5.2.4 UE capability information	17
5.1.5.2.5 Handover to UTRAN information flows, typical example.....	17
5.1.6 Measurements for Handover.....	20
5.1.6.1 Monitoring of FDD cells on the same frequency	20
5.1.6.2 Monitoring cells on different frequencies	20
5.1.6.2.1 Monitoring of FDD cells on a different frequency	20
5.1.6.2.2 Monitoring of TDD cells	21
5.1.6.2.2.2 Setting of compressed mode parameters with prior timing information between FDD serving cell and TDD target cells.....	21
5.1.6.2.3 Monitoring of GSM cells.....	21
5.1.7 Transfer of RRC information across interfaces other than Uu.....	23
5.1.7.1 Introduction and general principles	23
5.1.7.2 Message sequence diagrams.....	24
5.1.7.3 General error handling for RRC containers	26
6 Admission Control	28
6.1 Introduction	28
6.2 Examples of CAC strategies.....	28

6.3	Scenarios	28
6.3.1	CAC performed in SRNC	28
6.3.2	CAC performed in DRNC	29
6.3.2.1	Case of DCH	29
6.3.2.2	Case of Common Transport Channels	30
7	Radio Bearer Control.....	30
7.1	Usage of Radio Bearer Control procedures.....	30
7.1.1	Examples of Radio Bearer Setup	31
7.1.2	Examples of Physical Channel Reconfiguration.....	31
7.1.2.1	Increased UL data, with switch from RACH/FACH to DCH/DCH.....	31
7.1.2.2	Increased DL data, no Transport channel type switching	32
7.1.2.3	Decrease DL data, no Transport channel type switching	32
7.1.2.4	Decreased UL data, with switch from DCH/DCH to RACH/FACH	33
7.1.3	Examples of Transport Channel Reconfiguration.....	33
7.1.3.1	Increased UL data, with no transport channel type switching.....	33
7.1.3.2	Decreased DL data, with switch from DCH/DCH to RACH/FACH	34
7.1.4	Examples of Radio Bearer Reconfiguration	34
8	Dynamic Resource Allocation.....	35
8.1	Code Allocation Strategies for FDD mode.....	35
8.1.1	Introduction.....	35
8.1.2	Criteria for Code Allocation	36
8.1.3	Example of code Allocation Strategies	36
8.1.4	PDSCH code management.....	37
8.2	DCA (TDD).....	39
8.2.1	Channel Allocation	39
8.2.1.1	Resource allocation to cells (slow DCA)	39
8.2.1.2	Resource allocation to bearer services (fast DCA).....	40
8.2.2	Measurements Reports from UE to the UTRAN	40
9	Power Management.....	41
9.1	Variable Rate Transmission	41
9.1.1	Examples of Downlink Power Management	41
9.1.2	Examples of Uplink Power Management	41
9.2	Site Selection Diversity Power Control (SSDT)	42
9.3	Examples of balancing Downlink power.....	43
9.3.1	Adjustment loop.....	43
10	Radio Link Surveillance.....	43
10.1	Mode Control strategies for TX diversity.....	43
10.1.1	TX diversity modes.....	43
10.1.2	Mode Control Strategies	43
10.1.2.1	DPCH.....	43
10.1.2.2	Common channels.....	44
11	Codec mode control.....	44
11.1	AMR mode control.....	44
Annex A:	Simulations on Fast Dynamic Channel Allocation.....	46
A.1	Simulation environment	46
A.2	Results	46
A.2.1	Macro UDD 144	46
A.2.2	Micro UDD 384.....	47
A.2.2.1	Code rate 1	47
A.2.2.2	Code rate 2/3	48
A.3	Conclusions	48
Annex B:	Radio Bearer Control – Overview of Procedures: message exchange and parameters used	49
B.1	Examples of Radio Bearer Setup.....	49
B.1.1	RRC Parameters in RB Setup	49
B.1.2	RRC Parameters in RB Setup Complete.....	49
B.2	Examples of Physical Channel Reconfiguration	49

B.2.1	Increased UL data, with switch from RACH/FACH to DCH/DCH	50
B.2.1.1	RRC Parameters in Measurement Report	50
B.2.1.2	RRC Parameters in Physical Channel Reconfiguration	50
B.2.1.3	RRC Parameters in Physical Channel Reconfiguration Complete	50
B.2.2	Increased DL data, no Transport channel type switching	51
B.2.2.1	RRC Parameters in Physical Channel Reconfiguration	51
B.2.2.2	RRC Parameters in Physical Channel Reconfiguration Complete	51
B.2.3	Decrease DL data, no Transport channel type switching.....	51
B.2.3.1	RRC Parameters in Physical Channel Reconfiguration	52
B.2.3.2	RRC Parameters in Physical Channel Reconfiguration Complete	52
B.2.4	Decreased UL data, with switch from DCH/DCH to RACH/FACH	52
B.2.4.1	RRC Parameters in Physical Channel Reconfiguration	52
B.2.4.2	RRC Parameters in Physical Channel Reconfiguration Complete	52
B.3	Examples of Transport Channel Reconfiguration	52
B.3.1	Increased UL data, with no transport channel type switching	52
B.3.1.1	RRC Parameters in Measurement Report	53
B.3.1.2	RRC Parameters in Transport Channel Reconfiguration	53
B.3.1.3	RRC Parameters in Transport Channel Reconfiguration Complete	53
B.3.2	Decreased DL data, with switch from DCH/DCH to RACH/FACH	54
B.3.2.1	RRC Parameters in Transport Channel Reconfiguration	54
B.3.2.2	RRC Parameters in Transport Channel Reconfiguration Complete	54
B.4	Examples of RB Reconfiguration.....	54
B.4.1	RRC Parameters in Radio Bearer Reconfiguration.....	54
B.4.2	RRC Parameters in Radio Bearer Reconfiguration Complete	55
Annex C:	Flow-chart of a Soft Handover algorithm.....	56
Annex D:	SSDT performance.....	57
Annex E:	Simulation results on DL Variable Rate Packet Transmission	58
E.1	Simulation assumption	58
E.2	Simulation results	58
Annex F:	Simulation results on Adjustment loop.....	60
F.1	Simulation conditions.....	60
F.2	Simulation results	60
F.3	Interpretation of results	62
Annex G:	Simulation results for CPCH	63
G.1	Simulation Assumptions.....	63
G.2	CPCH Channel Selection Algorithms	64
G.2.1	Simple CPCH channel selection algorithm.....	64
G.2.2	The recency table method.....	64
G.2.3	The idle-random method.....	64
G.3	Simulation Results.....	64
G.3.1	Cases A-B: Comparison of idle-random method and the recency method for 30 ms packet inter-arrival time, 480 bytes, and 6 CPCH channels, each @384 ksps.....	64
G.3.2	Case C-D-E: Comparison of the three methods for multiple CPCH.....	65
G.3.3	Cases E-F: Impact of packet inter-arrival time	67
G.3.4	Case G: Number of mobiles in a cell	68
G.3.5	Case H-I: Comparison of recency and idle-random methods for single CPCH.....	68
G.3.6	Case H and J: Comparison of single CPCH and multiple CPCH, idle-random at 2 Msps.....	69
G.4	Discussion on idle-AICH and use of TFCI	69
G.5	Recommended RRM Strategies	69
Annex H:	Examples of RACH/PRACH Configuration	70
H.1	Principles of RACH/PRACH Configuration.....	70
Annex I:	Example of PCPCH assignment with VCAM	72
Annex J:	Change history	74
History		75

Foreword

This Technical Report (TR) has been produced by the 3rd Generation Partnership Project (3GPP).

The contents of the present document are subject to continuing work within the TSG and may change following formal TSG approval. Should the TSG modify the contents of the present document, it will be re-released by the TSG with an identifying change of release date and an increase in version number as follows:

Version x.y.z

where:

- x the first digit:
 - 1 presented to TSG for information;
 - 2 presented to TSG for approval;
 - 3 or greater indicates TSG approved document under change control.
- y the second digit is incremented for all changes of substance, i.e. technical enhancements, corrections, updates, etc.
- z the third digit is incremented when editorial only changes have been incorporated in the document.

1 Scope

The present document shall describe RRM strategies supported by UTRAN specifications and typical algorithms.

2 References

The following documents contain provisions which, through reference in this text, constitute provisions of the present document.

- References are either specific (identified by date of publication, edition number, version number, etc.) or non-specific.
- For a specific reference, subsequent revisions do not apply.
- For a non-specific reference, the latest version applies. In the case of a reference to a 3GPP document (including a GSM document), a non-specific reference implicitly refers to the latest version of that document *in the same Release as the present document*.

- [1] 3GPP Homepage: www.3gpp.org.
- [2] 3GPP TS 25.212: "Multiplexing and channel coding".
- [3] 3GPP TS 25.215: "Physical layer – Measurements (FDD)".
- [4] 3GPP TS 25.301: "Radio Interface Protocol Architecture".
- [5] 3GPP TS 25.302: "Services provided by the Physical Layer".
- [6] 3GPP TS 25.303: "Interlayer Procedures in Connected Mode".
- [7] 3GPP TS 25.304: "UE procedures in Idle Mode and Procedures for Cell Reselection in Connected Mode".
- [8] 3GPP TS 25.322: "RLC Protocol Specification".
- [9] 3GPP TS 25.331: "Radio Resource Control (RRC); protocol specification".
- [10] 3GPP TS 25.921: "Guidelines and Principles for protocol description and error handling".
- [11] 3GPP TR 21.905: "Vocabulary for 3GPP Specifications".
- [12] 3GPP TS 26.010: "Mandatory Speech Codec speech processing functions AMR Speech Codec General Description".
- [13] 3GPP TS 23.122: "Non-Access-Stratum functions related to Mobile Station (MS) in idle mode".
- [14] 3GPP TS 33.102: "3G Security; Security Architecture".
- [15] 3GPP TS 25.123: "Requirements for support of radio resource management (TDD)".
- [16] 3GPP TS 25.133: "Requirements for support of radio resource management (FDD)".
- [17] 3GPP TS 25.224: "Physical Layer Procedures (TDD)".
- [18] 3GPP TS 25.321: "MAC protocol specification".
- [19] 3GPP TS 22.011: "Service accessibility".

3 Definitions and abbreviations

3.1 Definitions

For the purposes of the present document, the terms and definitions given in [9] apply.

3.2 Abbreviations

For the purposes of the present document, the following abbreviations apply:

AC	Access Class of UE
AS	Access Stratum
ARQ	Automatic Repeat Request
BCCH	Broadcast Control Channel
BCH	Broadcast Channel
C-	Control-
CC	Call Control
CCCH	Common Control Channel
CCH	Control Channel
CCTrCH	Coded Composite Transport Channel
CN	Core Network
CRC	Cyclic Redundancy Check
DC	Dedicated Control (SAP)
DCA	Dynamic Channel Allocation
DCCH	Dedicated Control Channel
DCH	Dedicated Channel
DL	Downlink
DRNC	Drift Radio Network Controller
DSCH	Downlink Shared Channel
DTCH	Dedicated Traffic Channel
FACH	Forward Link Access Channel
FCS	Frame Check Sequence
FDD	Frequency Division Duplex
GC	General Control (SAP)
GSM	Global System for Mobile Communications
HCS	Hierarchical Cell Structure
HO	Handover
ITU	International Telecommunication Union
kbps	kilo-bits per second
L1	Layer 1 (physical layer)
L2	Layer 2 (data link layer)
L3	Layer 3 (network layer)
LAI	Location Area Identity
MAC	Medium Access Control
MM	Mobility Management
NAS	Non-Access Stratum
Nt	Notification (SAP)
PCCH	Paging Control Channel
PCH	Paging Channel
PDU	Protocol Data Unit
PHY	Physical layer
PhyCH	Physical Channels
PLMN	Public Land Mobile Network
RACH	Random Access Channel
RAT	Radio Access Technology
RLC	Radio Link Control
RNC	Radio Network Controller
RNS	Radio Network Subsystem

RNTI	Radio Network Temporary Identity
RRC	Radio Resource Control
SAP	Service Access Point
SCCH	Synchronisation Control Channel
SCH	Synchronisation Channel
SDU	Service Data Unit
SRNC	Serving Radio Network Controller
SRNS	Serving Radio Network Subsystem
TCH	Traffic Channel
TDD	Time Division Duplex
TFCI	Transport Format Combination Indicator
TFI	Transport Format Indicator
TMSI	Temporary Mobile Subscriber Identity
TPC	Transmit Power Control
U-	User-
UE	User Equipment
UL	Uplink
UMTS	Universal Mobile Telecommunications System
URA	UTRAN Registration Area
UTRA	UMTS Terrestrial Radio Access
UTRAN	UMTS Terrestrial Radio Access Network

4 Idle Mode Tasks

4.1 Overview

When a UE is switched on, a public land mobile network (PLMN) is selected and the UE searches for a suitable cell of this PLMN to camp on. The PLMN selection procedures are specified in [13].

A PLMN may rely on several radio access technologies (RATs), e.g. UTRA and GSM. The non-access stratum can control the RATs in which the cell selection should be performed, for instance by indicating RATs associated with the selected PLMN [13]. The UE shall select a suitable cell and the radio access mode based on idle mode measurements and cell selection criteria.

The UE will then register its presence, by means of a NAS registration procedure, in the registration area of the chosen cell, if necessary.

When camped on a cell, the UE shall regularly search for a better cell according to the cell re-selection criteria. If a better cell is found, that cell is selected.

Different types of measurements are used in different RATs and modes for the cell selection and re-selection. The performance requirements for the measurements are specified in [15][16].

The description of cell selection and re-selection reported below applies to a multi-RAT UE with at least UTRA technology.

4.2 Service type in Idle mode

Services are distinguished into categories defined in [7]; also the categorisation of cells according to services they can offer is provided in [7].

In the following, some typical examples of the use of the different types of cells are provided:

- Cell barred. In some cases (e.g. due to traffic load or maintenance reasons) it may be necessary to temporarily prevent the normal access in a cell. An UE shall not camp on a barred cell, not even for limited services.
- Cell reserved for operator use. The aim of this type of cell is to allow the operator using and test newly deployed cells without being disturbed by normal traffic. For normal users (indicated by assigned AC 0 to 9) and special

non-operator users (indicated by assigned AC 12 to 14), the UE shall behave as for the cell barred. UEs with AC 11 or 15 are allowed to reselect those cells while in HomePLMN.

The cell type is indicated in the system information [9].

4.3 Criteria for Cell Selection and Reselection

4.3.1 Cell Selection

The goal of the cell selection procedures is to fast find a cell to camp on. To speed up this process, when switched on or when returning from "out of coverage", the UE shall start with the stored information from previous network contacts. If the UE is unable to find any of those cells the initial cell search procedure will be initiated.

The UE shall measure CPICH E_c/N_o and CPICH RSCP for FDD cells and P-CCPCH RSCP for TDD cells [7].

If it is not possible to find a cell from a valid PLMN the UE will choose a cell in a forbidden PLMN and enter a "limited service state". In this state the UE regularly attempt to find a suitable cell on a valid PLMN. If a better cell is found the UE has to read the system information for that cell.

A cell is suitable if it fulfils the cell selection criterion S specified in [7]:

In order to define a minimum quality level for camping on the cell, a quality threshold different for each cell can be used. The quality threshold for cell selection is indicated in the system information.

4.3.2 Cell Re-selection

The goal of the cell re-selection procedure is to always camp on a cell with good enough quality even if it is not the optimal cell all the time. When camped normally, the UE shall monitor relevant System Information and perform necessary measurements for the cell reselection evaluation procedure.

The cell reselection evaluation process, i.e. the process to find whether a better cell exist, is performed on a UE internal trigger [15][16] or when the system information relevant for cell re-selection are changed.

4.3.2.1 Hierarchical Cell Structures

The radio access network may be designed using hierarchical cell structures. An example of hierarchical cell structure is shown below. Numbers in the picture describe different layers in the hierarchy. The highest hierarchical layer, i.e. typically smallest cell size, has the higher priority (number 1 in the figure).

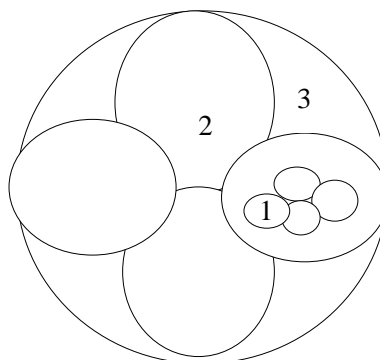

Figure 4-1: Example of Hierarchical Cell Structure

Different layers can be created using different frequencies. However, different frequencies can also be used on the same hierarchical layer e.g. in order to cope with high load in the system.

The operator can control the transitions between two layers or between any two cells, regardless of whether the two cells have equal or different priority. The control is performed both in terms of measurements on target cells and in terms of parameter settings in order to achieve hysteresis and cell border offset effects.

In order to cope with UEs travelling fast through smaller cells (e.g. through micro or pico cells), the cell reselection procedure can be performed towards bigger cells on lower layers e.g. to macro cells so as to avoid unnecessary cell reselections.

4.3.2.2 Measurements for cell re-selection

The quality measurements to be performed on the cells candidate for cell re-selection are controlled by the UTRAN. According to the quality level of the serving cell and the threshold indicated in the system information, the UE measurements are triggered fulfilling different requirements for intra-frequency, inter-frequency or inter-RAT quality estimation.

When HCS is used, it is also possible to further restrict the range of the measured cells, considering only the cells at higher priority level HCS_PRIO. Moreover the UE speed may be taken into account. When a the number of reselections during a time period T_{CRmax} exceeds the value N_{CR} given in the system information, the UE is considered in high-mobility state. In this case the measurements are performed on the cells that have equal or lower HCS_PRIO than the serving cell. If the number of reselection during T_{CRmax} no longer exceeds N_{CR} , the UE leaves the high-mobility state after a time period $T_{CRmaxHyst}$. Parameters for measurement control are indicated in the system information [9]

4.3.2.3 Cell re-selection criteria

The cells on which the UE has performed the measurement and that fulfil the S criterion specified for cell selection are candidates for cell reselection.

These cells are ranked according to the criterion R [7]. The quality of the target cells is evaluated and compared with the serving cell by mean of relative offsets.

When the serving cell belongs to a HCS (i.e. HCS is indicated in the system information), a temporary offset applies for a given penalty time to the cells on the same priority level as the serving cell.

When HCS is used, an additional criterion H is used to identify target cells on a different layer. During the quality estimation of those cells, a temporary offset applies for a given penalty time. If the quality requirement H is fulfilled, the cells belonging to the higher priority level are included for cell re-selection and ranked according to the criterion R. However, if the UE is in the high-mobility state, this rule does not apply and the ranking is performed on the candidate cells according to the measurements performed.

The cell with higher value R in the ranking list is chosen as new cell if all the criteria described above are fulfilled during a time interval $T_{reselection}$.

All the counters, timers, offsets and thresholds used to control the re-selection evaluation process are indicated in the system information [9]. These parameters are unique on a cell-to-neighbour-cell relation basis. This implies that the UE does not need to read the system information in the neighbouring cells before the cell reselection procedure finds a neighbouring cell with better quality

4.3.3 Mapping of thresholds in cell reselection rules

When HCS is used, mapping of signalled values for the thresholds Q_{hcs} shall be used. Different mapping is applied for CPICH Ec/N0 and CPICH RSCP for FDD cells, P-CCPCH RSCP for TDD cells, and RSSI for GSM cells. The explicit mapping is indicated in system information [9].

4.3.4 Reserved cells

When cell status "barred" is indicated [9] the UE is not permitted to select/re-select this cell, not even for limited services.

When the cell status "reserved for operator use" is indicated [9] and the access class of the UE is 11 or 15 the UE may select/re-select this cell if in HomePLMN [19].

In all these cases, the criteria for selection of another cell should take into account the effects of the interference generated towards the reserved cell. For this reason, the reselection of any cell on the same frequency as the reserved cell is prohibited and the UE enters a limited service state. In this state, in order to detect a change of the reservation status, the UE shall perform a periodic check every T_{barred} seconds.

When the neighbour cells use only the same frequency, the only way to provide the service in the area is to allow the UE to camp on another cell on the same frequency, regardless of the interference generated on the reserved cell. This is done by setting the "Intra-frequency cell re-selection indicator" IE to "allowed".

When the UE still detect the reserved cell as the "best" one, it will read the system information and evaluate again the availability of that cell, increasing the power consumption in the UE. The unnecessary evaluation may be avoided excluding the restricted cell from the neighbouring cell list for a time interval of T_{barred} seconds.

"Intra-frequency cell re-selection indicator" and " T_{barred} " are indicated together with the cell access restriction in the system information [9].

4.4 Location Registration

The location registration procedure is defined in [13]. The strategy used for the update of the location registration has to be set by the operator and, for instance, can be done regularly and when entering a new registration area. The same would apply for the update of the NAS defined service area, which can be performed regularly, and when entering a new NAS defined service area.

5 RRC Connection Mobility

5.1 Handover

5.1.1 Strategy

The handover strategy employed by the network for radio link control determines the handover decision that will be made based on the measurement results reported by the UE/RNC and various parameters set for each cell. Network directed handover might also occur for reasons other than radio link control, e.g. to control traffic distribution between cells. The network operator will determine the exact handover strategies. Possible types of Handover are as follows:

- Handover 3G -3G;
- FDD soft/softer handover;
- FDD inter-frequency hard handover;
- FDD/TDD Handover;
- TDD/FDD Handover;
- TDD/TDD Handover;
- Handover 3G - 2G (e.g. Handover to GSM);
- Handover 2G - 3G (e.g. Handover from GSM).

5.1.2 Causes

The following is a non-exhaustive list for causes that could be used for the initiation of a handover process.

- Uplink quality;
- Uplink signal measurements;
- Downlink quality;

- Downlink signal measurements;
- Distance;
- Change of service;
- Better cell;
- O&M intervention;
- Directed retry;
- Traffic;
- Pre-emption.

5.1.3 Hard Handover

The hard handover procedure is described in [6].

Two main strategies can be used in order to determine the need for a hard handover:

- received measurements reports;
- load control.

5.1.4 Soft Handover

5.1.4.1 Soft Handover Parameters and Definitions

Soft Handover is a handover in which the mobile station starts communication with a new Node-B on a same carrier frequency, or sector of the same site (softer handover), performing utmost a change of code. For this reason Soft Handover allows easily the provision of macrodiversity transmission; for this intrinsic characteristic terminology tends to identify Soft Handover with macrodiversity even if they are two different concepts; for its nature soft handover is used in CDMA systems where the same frequency is assigned to adjacent cells. As a result of this definition there are areas of the UE operation in which the UE is connected to a number of Node-Bs. With reference to Soft Handover, the "Active Set" is defined as the set of Node-Bs the UE is simultaneously connected to (i.e., the UTRA cells currently assigning a downlink DPCH to the UE constitute the active set).

The Soft Handover procedure is composed of a number of single functions:

- Measurements;
- Filtering of Measurements;
- Reporting of Measurement results;
- The Soft Handover Algorithm;
- Execution of Handover.

The measurements of the monitored cells filtered in a suitable way trigger the reporting events that constitute the basic input of the Soft Handover Algorithm.

The definition of 'Active Set', 'Monitored set', as well as the description of all reporting events is given in [9].

Based on the measurements of the set of cells monitored, the Soft Handover function evaluates if any Node-B should be added to (Radio Link Addition), removed from (Radio Link Removal), or replaced in (Combined Radio Link Addition and Removal) the Active Set; performing than what is known as "Active Set Update" procedure.

5.1.4.2 Example of a Soft Handover Algorithm

A describing example of a Soft Handover Algorithm presented in this subclause which exploits reporting events 1A, 1B, and 1C described in [9]. It also exploits the Hysteresis mechanism and the Time to Trigger mechanism described in [9]. Any of the measurements quantities listed in [9] can be considered.

Other algorithms can be envisaged that use other reporting events described in [9]; also load control strategies can be considered for the active set update, since the soft handover algorithm is performed in the RNC.

For the description of the Soft Handover algorithm presented in this subclause the following parameters are needed:

- AS_Th: Threshold for macro diversity (reporting range);
- AS_Th_Hyst: Hysteresis for the above threshold;
- AS_Rep_Hyst: Replacement Hysteresis;
- ΔT : Time to Trigger;
- AS_Max_Size: Maximum size of Active Set.

The following figure describes this Soft Handover Algorithm.

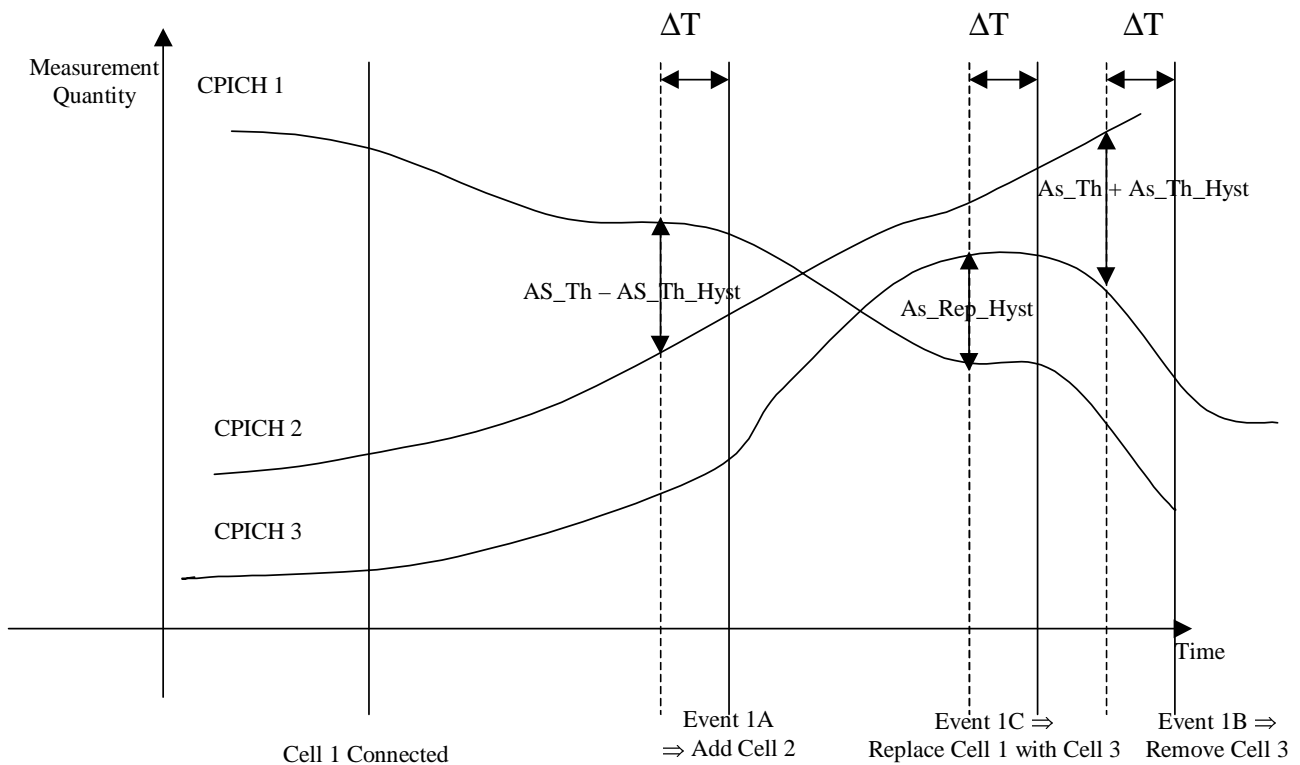

Figure 5-1: Example of Soft Handover Algorithm

As described in the figure above:

- If Meas_Sig is below $(Best_Ss - AS_Th - AS_Th_Hyst)$ for a period of ΔT remove Worst cell in the Active Set.
- If Meas_Sig is greater than $(Best_Ss - AS_Th + AS_Th_Hyst)$ for a period of ΔT and the Active Set is not full add Best cell outside the Active Set in the Active Set.
- If Active Set is full and Best_Cand_Ss is greater than $(Worst_Old_Ss + AS_Rep_Hyst)$ for a period of ΔT add Best cell outside Active Set and Remove Worst cell in the Active Set.

Where:

- Best_Ss :the best measured cell present in the Active Set;
- Worst_Old_Ss: the worst measured cell present in the Active Set;
- Best_Cand_Set: the best measured cell present in the monitored set.
- Meas_Sign :the measured and filtered quantity.

A flow-chart of the above described Soft Handover algorithm is available in Appendix C.

5.1.4.3 Soft Handover Execution

The Soft Handover is executed by means of the following procedures described in [6]:

- Radio Link Addition (FDD soft-add);
- Radio Link Removal (FDD soft-drop);
- Combined Radio Link Addition and Removal.

The serving cell(s) (the cells in the active set) are expected to have knowledge of the service used by the UE. The new cell decided to be added to the active set shall be informed that a new connection is desired, and it needs to have the following minimum information forwarded from the RNC:

- Connection parameters, such as coding schemes, number of parallel code channels etc. parameters which form the set of parameters describing the different transport channel configurations in use both uplink and downlink.
- The UE ID and uplink scrambling code.
- The relative timing information of the new cell, in respect to the timing UE is experiencing from the existing connections (as measured by the UE at its location). Based on this, the new Node-B can determine what should be the timing of the transmission initiated in respect to the timing of the common channels (CPICH) of the new cell.

As a response the UE needs to know via the existing connections:

- What channelisation code(s) are used for that transmission. The channelisation codes from different cells are not required to be the same as they are under different scrambling codes.
- The relative timing information, which needs to be made available at the new cell is indicated in Figure 5-1 (shows the case where the two involved cells are managed by different Node-Bs).

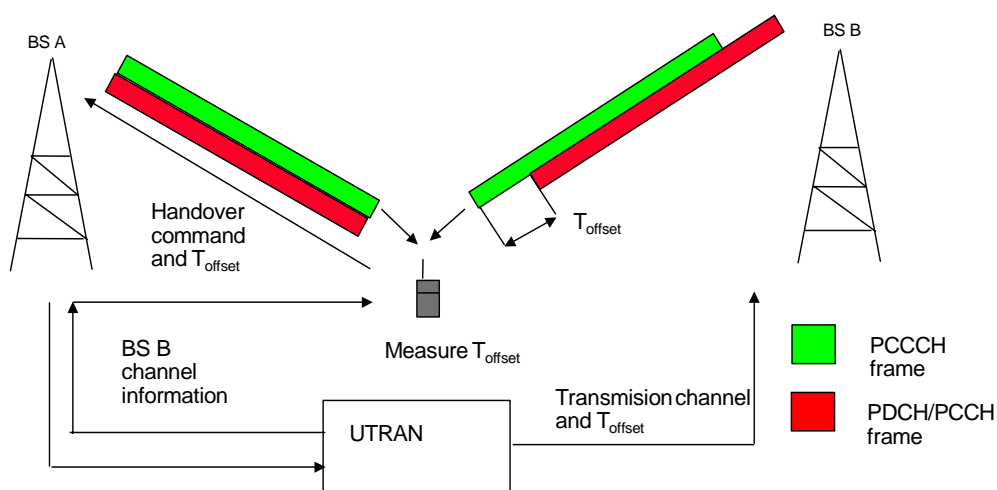

Figure 5-2: Making transmissions capable to be combined in the Rake receiver from timing point of view

At the start of diversity handover, the reverse link dedicated physical channel transmitted by the UE, and the forward link dedicated physical channel transmitted by the diversity handover source Node-B will have their radio frame

number and scrambling code phase counted up continuously as usual, and they will not change at all. Naturally, the continuity of the user information mounted on them will also be guaranteed, and will not cause any interruption.

5.1.5 Inter Radio Access Technology Handover

5.1.5.1 Handover 3G to 2G

The handover from UTRA to GSM (offering world-wide coverage already today) has been one of the main design criteria taken into account in the UTRA frame timing definition.

The handover from UTRA FDD mode to GSM can also be implemented without simultaneous use of two receiver chains. Although the frame length is different from GSM frame length, the GSM traffic channel and UTRA FDD channels use similar multi-frame structure.

A UE can do the measurements by using idle periods in the downlink transmission, where such idle periods are created by using the downlink compressed mode as defined in [2]. The compressed mode is under the control of the UTRAN and the UTRAN signals appropriate configurations of compressed mode pattern to the UE. For some measurements also uplink compressed mode is needed, depending on UE capabilities and measurement objects.

Alternatively independent measurements not relying on the compressed mode, but using a dual receiver approach can be performed, where the GSM receiver branch can operate independently of the UTRA FDD receiver branch.

The handover from UTRA TDD mode to GSM can be implemented without simultaneous use of two receiver chains. Although the frame length is different from GSM frame length, the GSM traffic channel and UTRA TDD channels rely on similar multi-frame structure.

A UE can do the measurements either by efficiently using idle slots or by getting assigned free continuous periods in the downlink part obtained by reducing the spreading factor and compressing in time TS occupation in a form similar to the FDD compressed mode.

For smooth inter-operation, inter-system information exchanges are needed in order to allow the UTRAN to notify the UE of the existing GSM frequencies in the area and vice versa. Further more integrated operation is needed for the actual handover where the current service is maintained.

5.1.5.2 Handover 2G to 3G

In the following clauses, first the general concept and requirements are introduced. Next the typical flow of information is described.

5.1.5.2.1 Introduction

The description provided in the following mainly deals with the use of predefined radio configuration during handover from 2G to 3G. However, the description of the handover information flows also includes details of other RRC information transferred during handover e.g. UE radio capability and security information.

5.1.5.2.2 Predefined radio configuration information

In order to reduce the size of certain size critical messages in UMTS, a network may download/ pre-define one or more radio configurations in a mobile. A predefined radio configuration mainly consists of radio bearer- and transport channel parameters. A network knowing that the UE has suitable predefined configurations stored can then refer to the stored configuration requiring only additional parameters to be transferred.

Predefined configurations may be applied when performing handover from another RAT to UTRAN. In the case of handover from GSM to UTRAN, the performance of handover to UTRAN is improved when it is possible to transfer the handover to UTRAN command within a non-segmented GSM air interface message.

Furthermore, it is important to note that it is a network option whether or not to use pre-configuration; the handover to UTRAN procedures also support transfer of a handover to UTRAN command including all parameters and the use of default configurations.

NOTE: In case segmentation is used, subsequent segments can only be transferred after acknowledgement of earlier transmitted segments. In case of handover however, the quality of the UL may be quite poor resulting in a failure to transfer acknowledgements. This implies that it may be impossible to quickly transfer a segmented handover message. Segmentation over more than two GSM air interface messages will have a significantly detrimental, and unacceptable, impact on handover performance.

The UE shall be able to store upto 16 different predefined configurations, each of which is identified with a separate pre-configuration identity. The UE need not defer accessing the network until it has obtained all predefined configurations. The network may use different configurations for different services e.g. speech, circuit switched data. Moreover, different configurations may be needed because different UTRAN implementations may require service configurations to be customised e.g. different for micro and macro cells.

The predefined configurations stored within the UE are valid within the scope of a PLMN; the UE shall consider these configurations to be invalid upon PLMN re-selection. Furthermore, a value tag is associated with each individual pre-defined configuration. This value tag, that can have 16 values, is used by the UE and the network to ensure the stored pre-defined configuration(s) is the latest/required version. The UE erases all pre-defined configurations upon switch off.

The current facilities in 25.331 have focused on the use of predefined configurations during handover from GSM to UTRAN. The same principles may also be applied for the handover procedures used within UTRAN although this would require an extension of the currently defined RRC procedures.

5.1.5.2.2a Default configuration information

A default configuration is a set of radio bearer parameters for which the values are defined in the standard. While the network can configure the parameter values to be used in a predefined configuration in a flexible manner, the set of radio bearer parameter values for a default configuration are specified in the standard and hence fixed. The main advantage of default configurations is that they can be used at any time; they need not be downloaded into the UE.

5.1.5.2.3 Security and UE capability information

The security requirements concerning handover to UTRAN are specified in [14].

The initialisation parameters for ciphering are required to be transferred to the target RNC prior to the actual handover to UTRAN to ensure the immediate start of ciphering. For UEs involved in CS & PS domain services, R'99 specifications support handover for the CS domain services while the PS domain services are re-established later. Consequently, in R'99 only the START for the CS domain service needs to be transferred prior to handover. The START for the PS domain may be transferred at the end of the handover procedure, within the HANDOVER TO UTRAN COMPLETE message.

It should be noted that inter RAT handover normally involves a change of ciphering algorithm, in which case the new algorithm is included within the HANDOVER TO UTRAN COMMAND message.

Activation of integrity protection requires additional information transfer e.g. FRESH. Since the size of the HANDOVER TO UTRAN COMMAND message is critical, the required integrity protection information can not be included in this message. Instead, integrity protection is started immediately after handover by means of the security mode control procedure. Therefore, the HANDOVER TO UTRAN COMMAND and the HANDOVER TO UTRAN COMPLETE messages are not integrity protected.

5.1.5.2.4 UE capability information

When selecting the RRC radio configuration parameters to be included in the HANDOVER TO UTRAN COMMAND message, UTRAN should take into account the capabilities of the UE. Therefore, the UE radio capability information should be transferred to the target RNC prior to handover to UTRAN

5.1.5.2.5 Handover to UTRAN information flows, typical example

The handover to UTRAN procedure may include several subsequent information flows. The example described in this subclause is representative of a typical sequence of information flows. It should be noted that some procedures may actually be performed in parallel e.g. configuration of UTRA measurements and downloading of pre-defined configurations.

NOTE: Since work is ongoing in this area, the names of the information flows provided in the following diagrams may not reflect the latest status of standards/ CRs.

The description includes the different network nodes and interfaces involved in the handover to UTRAN procedure.

Flow 1: Downloading of predefined configuration information within UTRA

If the mobile uses UTRA prior to entering another RAT, it may download predefined configuration information as shown in the following diagram. UTRAN broadcasts predefined configuration information within the system information. The UE should read and store all the configurations broadcast by UTRAN. The configurations should be used when re- entering UTRAN.

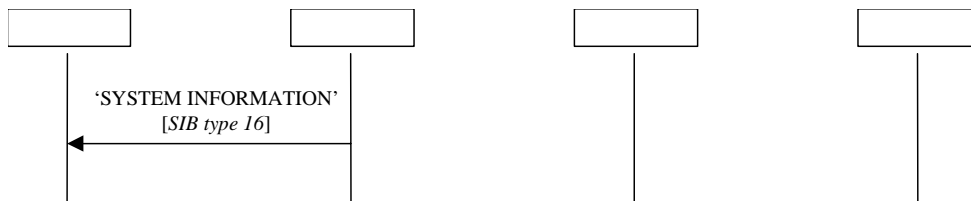

In order to reduce the likelihood that a UE starts a call in GSM/ GPRS without having a valid pre-defined configuration stored, UEs that do not have pre-defined configurations stored may temporarily prioritise UMTS cells.

Flow 2: UE capability, security and pre- defined configuration information exchange

In order to prepare for handover to UTRAN, the BSS may retrieve UE capability, security and pre- defined configuration status information by means of the sequence shown below. This procedure may not only be invoked upon initial entry of a mobile supporting UTRA within GSM, but also when the mobile continues roaming within the GSM network. It should be noted that, the mobile could also send the information automatically by means of the early classmark change procedure.

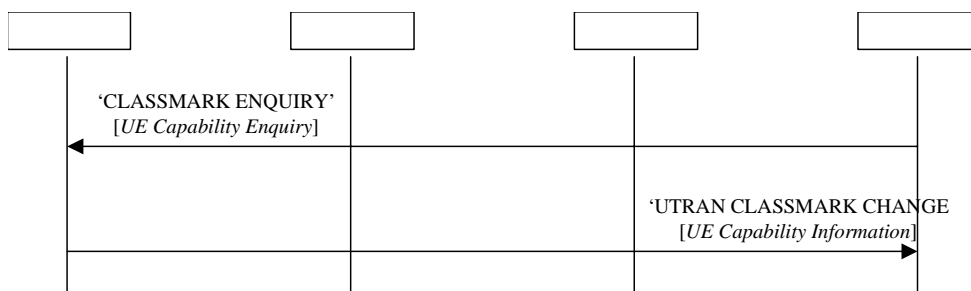

Furthermore, pre- defined configuration status information may be transferred to the BSS during handover from UTRAN.

The BSS has to store the received information until the handover to UTRAN is invoked.

NOTE 1: During the handover procedure, the stored UE capability and security information is sent to the target RNC.

NOTE 2: Depending on the received predefined configuration status information, the BSS may need to invoke the procedure for downloading predefined configurations, as described in flow 4

Flow 3: Configuration of UTRA measurements

The BSS configures the UTRA measurements to be performed by the mobile, including the concerned thresholds and the reporting parameters, by means of the following information flow.

NOTE: The BSS may possibly decide the measurement configuration to be used based upon previously received UE capability information (e.g. supported modes & bands)

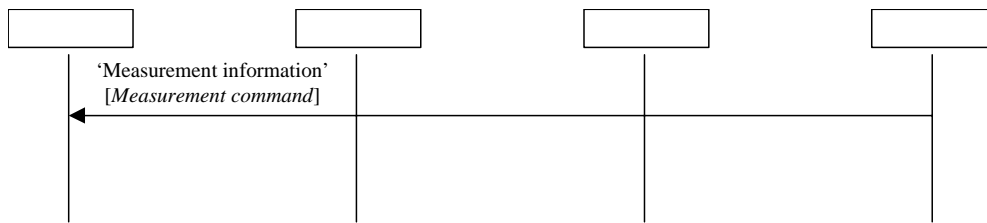

NOTE: The network may also provide information about neighbouring UTRAN cells within the CHANNEL RELEASE message.

Flow 4: Downloading of pre- defined radio bearer configurations within GSM

The pre-defined configuration status information (indicating which configurations are stored, as well as their value tags) is included in the UTRAN CLASSMARK CHANGE message This information may indicate that the UE does not have the required predefined configuration stored, in which case the BSS should initiate the transfer of these configurations by means of the information flow shown below.

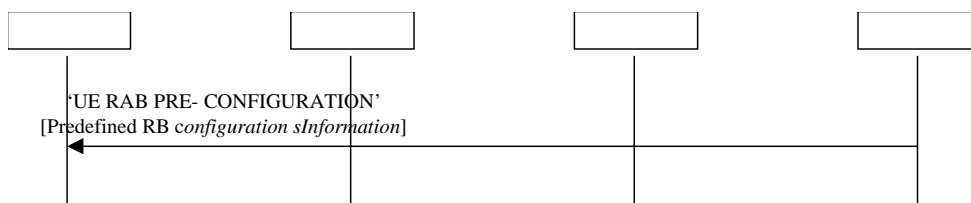

The handover to UTRAN procedures for this release should not rely on the support of the procedure for the downloading of pre-defined radio bearer configurations within GSM.

Flow 5: Handover

When the BSS decides that handover to UTRAN should be performed, triggered by the reception of a measurement report, it initiates the handover procedure. Next, the CN requests resources by sending a Relocation request to the target RNC. This message should include the UE capability and security information previously obtained by the BSS. The pre- defined configuration status information should be included in the Relocation request also. The main reason for this it that when selecting the predefined configuration to be indicated within the handover to UTRAN command message, the target RNC should know if the UE has downloaded all predefined configurations or only a subset.

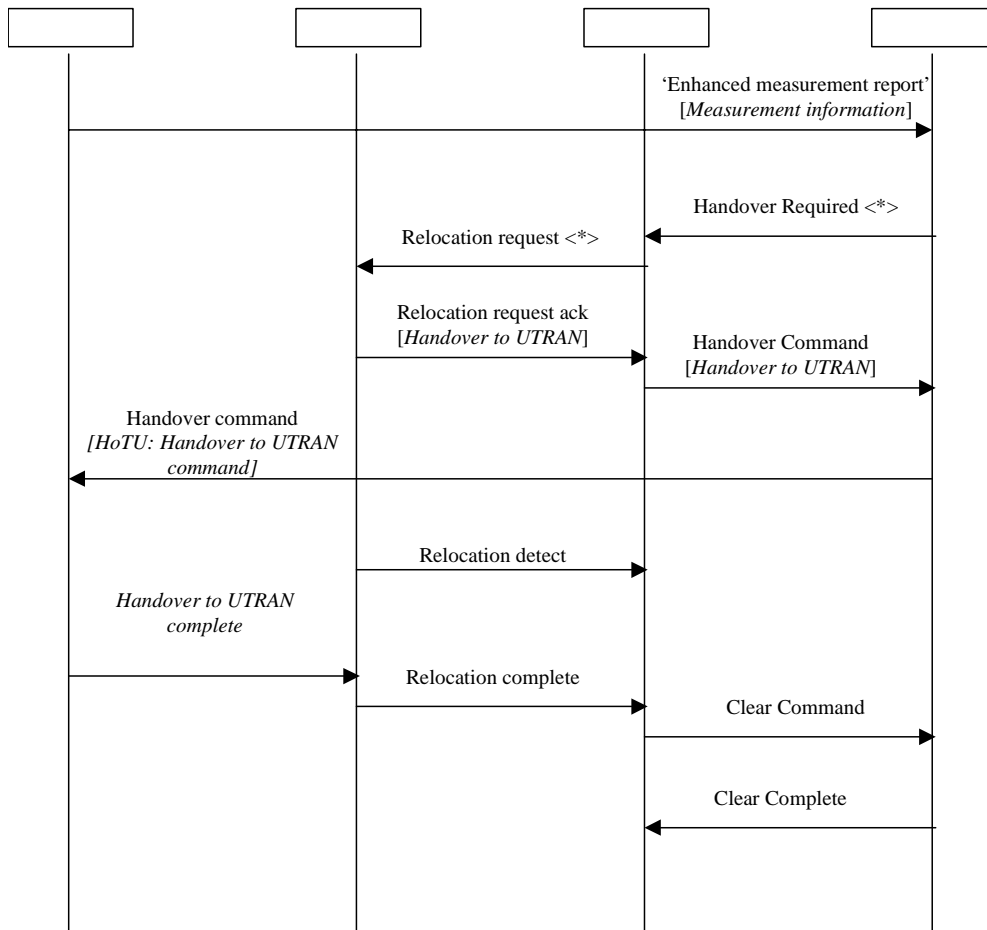

The relocation request includes an indication of the service type for which the handover is requested. This information is used by the target RNC to select the predefined configuration to be used by the UE, which is included within the handover to UTRAN command.

In case no (suitable) predefined configuration is stored within the UE, the network may either completely specify all radio bearer, transport channel and physical channel parameters or apply a default configuration (FFS).

5.1.6 Measurements for Handover

5.1.6.1 Monitoring of FDD cells on the same frequency

The UE shall be able to perform intra-frequency measurements simultaneously for data reception from the active set cell/s. If one or several compressed mode pattern sequences are activated, intra frequency measurements can be performed between the transmission gaps. During the measurement process of cells on the same frequencies, the UE shall find the necessary synchronisation to the cells to measure using the primary and secondary synchronisation channels and also the knowledge of the possible scrambling codes in use by the neighbouring cells.

The number of intra-frequency cells which the UE is able to measure and report to the UTRAN depends on the amount of time available to perform these measurements i.e. the time left by the activation of all compressed mode pattern sequences the UTRAN may activate is able to support depending on its capability (FDD, TDD, GSM). The rules to derive the number of cells, which can be reported by the UE depending on the characteristics of the activated compressed mode patterns, are given in [16].

5.1.6.2 Monitoring cells on different frequencies

5.1.6.2.1 Monitoring of FDD cells on a different frequency

Upper layers may ask FDD UE to perform preparation of inter-frequency handover to FDD. In such case, the UTRAN signals to the UE the neighbour cell list and if needed, the compressed mode parameters used to make the needed

measurements. Setting of the compressed mode parameters defined in [3] for the preparation of handover from UTRA FDD to UTRA FDD is indicated in the following subclause. Measurements to be performed by the physical layer are defined in [3].

5.1.6.2.1.1 Setting of parameters for transmission gap pattern sequence with purpose "FDD" measurements

During the transmission gaps, the UE shall perform measurements so as to be able to report to the UTRAN the frame timing, the scrambling code and the E_c/I_o of Primary CCPCH of up FDD cells in the neighbour cell list.

When requiring the UE to monitor inter-frequency FDD cells, the UTRAN may use any transmission gap pattern sequence with transmission gaps of length 5, 7, 10 and 14 slots.

The time needed by the UE to perform the required inter-frequency measurements according to what has been requested by the UTRAN depends on the transmission gap pattern sequence characteristics such as e.g. TGD, TGPL and TGPRC. The rules to derive these measurement times are given in [16].

5.1.6.2.2 Monitoring of TDD cells

Upper layers may ask dual mode FDD/TDD UE to perform preparation of inter-frequency handover to TDD. In such case, the UTRAN signals to the UE the handover monitoring set, and if needed, the compressed mode parameters used to make the needed measurements. Setting of the compressed mode parameters defined in [3] for the preparation of handover from UTRA FDD to UTRA TDD is indicated in the following subclause. Measurements to be performed by the physical layer are defined in clause 5.

5.1.6.2.2.1 Setting of the compressed mode parameters

When compressed mode is used for cell acquisition at each target TDD frequency, the parameters of compressed mode pattern are fixed to be:

TGL	TGD	TGP	PD

NOTE: settings for cell acquisition are FFS.

5.1.6.2.2.2 Setting of compressed mode parameters with prior timing information between FDD serving cell and TDD target cells

When UTRAN or UE have this prior timing information, the compressed mode shall be scheduled by upper layers with the intention that SCH on the specific TDD base station can be decoded at the UE during the transmission gap.

TGL	SFN	SN
4	(calculated by UTRAN)	(calculated by UTRAN)

5.1.6.2.3 Monitoring of GSM cells

Upper layers may ask a dual RAT FDD/GSM UE to perform preparation of inter-frequency handover to GSM. In such case, the UTRAN signals to the UE the neighbour cell list and, if needed, the compressed mode parameters used to make the needed measurements.

The involved measurements are covered by 3 measurement purposes "GSM RSSI" (Subclause 5.1.6.2.3.1), "GSM BSIC identification" (Subclause 5.1.6.2.3.2) and "GSM BSIC reconfirmation" (Subclause 5.1.6.2.3.3). A different transmission gap pattern sequence is supplied for each measurement purpose. This implies that when the UE is monitoring GSM, up to 3 transmission gap pattern sequences can be activated by the UTRAN.

5.1.6.2.3.1 Setting of parameters for transmission gap pattern sequence with purpose "GSM RSSI"

When compressed mode is used for GSM RSSI measurements, any transmission gap pattern sequence can be used which contains transmission gap of lengths 3, 4, 7, 10 or 14 slots.

In order to fulfil the expected GSM power measurements requirement, the UE can get effective measurement samples during a time window of length equal to the transmission gap length reduced by an implementation margin that includes the maximum allowed delay for a UE's synthesiser to switch from one FDD frequency to one GSM frequency and switch back to FDD frequency, plus some additional implementation margin.

The number of samples that can be taken by the UE during the allowed transmission gap lengths and their distribution over the possible GSM frequencies is given in [16].

5.1.6.2.3.2 Setting of parameters for transmission gap pattern sequence with purpose "GSM initial BSIC identification"

The setting of the compressed mode parameters is described in this subclause when used for first SCH decoding of one cell when there is no knowledge about the relative timing between the current FDD cells and the neighbouring GSM cell.

The table below gives a set of reference transmission pattern gap sequences that might be used to perform BSIC identification i.e. initial FCCH/SCH acquisition.

The time available to the UE to perform BSIC identification is equal to the transmission gap length minus an implementation margin that includes the maximum allowed delay for a UE's synthesiser to switch from one FDD frequency to one GSM frequency and switch back to FDD frequency, the UL/DL timing offset, and the inclusion of the pilot field in the last slot of the transmission gap for the case of downlink compressed mode.

	TGL1 [slots]	TGL2 [slots]	TGD [slots]	TGPL1 [frames]	TGPL2 [frames]	T _{identify abort} [s]	N _{identify abort} [patterns]
Pattern 1	7	0	0	3	0	1.53	51
Pattern 2	7	0	0	8	0	5.20	65
Pattern 3	7	7	47	8	0	2.00	25
Pattern 4	7	7	38	12	0	2.88	24
Pattern 5	14	0	0	8	0	1.76	22
Pattern 6	14	0	0	24	0	5.04	21
Pattern 7	14	14	45	12	0	1.44	12
Pattern 8	10	0	0	12	0	2.76	23
Pattern 9	10	10	75	12	0	1.56	13
Pattern 10	8	0	0	8	0	2.80	35
Pattern 11	8	0	0	4	0	1.52	38

For the above listed compressed mode patterns sequences, N_{identify abort} indicates the maximum number of patterns from the transmission gap pattern sequence which may be devoted by the UE to the identification of the BSIC of a given cell. T_{identify abort} times have been derived assuming the serial search and two SCH decoding attempts since the parallel search is not a requirement for the UE.

Each pattern corresponds to a different compromise between speed of GSM SCH search and rate of use of compressed frames. Requirements are set in [16] to ensure a proper behaviour of the UE depending on the signalled parameters.

5.1.6.2.3.3 Setting of parameters for transmission gap pattern sequence with purpose "GSM BSIC reconfirmation"

BSIC reconfirmation is performed by the UE using a separate compressed mode pattern sequence (either the same as for BSIC identification or a different one). When the UE starts BSIC reconfirmation for one cell using the compressed mode pattern sequence signalled by the UTRAN, it has already performed at least one decoding of the BSIC (during the initial BSIC identification).

UTRAN may have some available information on the relative timing between GSM and UTRAN cells. Two alternatives are considered for the scheduling of the compressed mode pattern sequence by the UTRAN for BSIC reconfirmation depending on whether or not UTRAN uses the timing information provided by the UE.

The requirements on BSIC reconfirmation are set in [16] independently of how the transmission gap pattern sequence are scheduled by the UTRAN. These requirements apply when the GSM SCH falls within the transmission gap of the transmission gap pattern sequence with a certain accuracy. The UTRAN may request the UE to re-confirm several BSICs within a given transmission gap.

The UTRAN may use any transmission gap pattern sequence with transmission gap length 5, 7, 8, 10 or 14 slots for BSIC reconfirmation. For the following reference transmission gap pattern sequences, $T_{\text{re-confirm_abort}}$ indicates the maximum time allowed for the re-confirmation of the BSIC of one GSM cell in the BSIC re-confirmation procedure, assuming a worst-case GSM timing. This parameter is signalled by the UTRAN to the UE with the compressed mode parameters.

	TGL1 [slots]	TGL2 [slots]	TGD [slots]	TGPL1 [frames]	TGPL2 [frames]	$T_{\text{re-confirm_abort}}$ [s]	$N_{\text{re-confirm_abort}}$ [patterns]
Pattern 1	7	0	0	3	0	1.29	43
Pattern 2	7	0	0	8	0	4.96	62
Pattern 3	7	0	0	15	0	7.95	53
Pattern 4	7	7	69	23	0	9.89	43
Pattern 5	7	7	69	8	0	2.64	33
Pattern 6	14	0	0	8	0	1.52	19
Pattern 7	14	14	60	8	0	0.80	10
Pattern 8	10	0	0	8	0	1.76	22
Pattern 9	10	0	0	24	0	4.80	20
Pattern 10	8	0	0	8	0	2.56	32
Pattern 11	8	0	0	23	0	7.82	34
Pattern 12	7	7	47	8	0	1.76	22
Pattern 13	7	7	38	12	0	2.64	22
Pattern 14	14	0	0	24	0	4.80	20
Pattern 15	14	14	45	12	0	1.20	10
Pattern 16	10	0	0	12	0	2.52	21
Pattern 17	10	10	75	12	0	1.32	11
Pattern 18	8	0	0	4	0	1.28	32

NOTE: it is to be decided within RAN WG4 whether 18 patterns should be kept for BSIC reconfirmation.

5.1.6.2.3.3.1 Asynchronous BSIC reconfirmation

In this case, the UTRAN provides a transmission gap pattern sequence without using information on the relative timing between UTRAN and GSM cells.

The way the UE should use the compressed mode pattern for each cell in case the BSIC reconfirmation is required for several cells is configured by the UTRAN using the $N_{\text{re-confirm_abort}}$ parameter, which is signalled with the transmission gap pattern sequence parameters. Requirements are set in [16] to ensure a proper behaviour of the UE depending on the signalled parameters.

5.1.6.2.3.3.2 Synchronous BSIC reconfirmation

When UTRAN has prior timing information, the compressed mode can be scheduled by upper layers with the intention that SCH(s) (or FCCH(s) if needed) of one or several specific GSM cells can be decoded at the UE during the transmission gap(s) i.e. the transmission gap(s) are positioned so that the SCH(s) of the target GSM cell(s) are in the middle of the effective measurement gap period(s). Which BSIC is to be reconfirmed within each gap is not explicitly signalled, but determined by the UE based on prior GSM timing measurements.

5.1.7 Transfer of RRC information across interfaces other than Uu

5.1.7.1 Introduction and general principles

During several procedures, e.g. handover to UTRAN, handover from UTRAN, SRNC relocation RRC information may need to be transferred across interfaces other than the UTRA air interface (Uu), e.g. Iu, A, Um interface. In order to maintain independence between the different protocols, to facilitate transparent handling by intermediate network nodes and to ease future extension, the preference is to use RRC information containers across such interfaces. In some cases however RRC messages may be used, e.g. for historical reasons.

An RRC information container is an extensible self-contained information unit that can be decoded without requiring information about the context, e.g. in which interface message it was included. In general an RRC information container is defined for each node that terminates/receives RRC information, e.g. the source RAT, target RNC. By definition, an RRC information container includes a choice facilitating the transfer of different types of RRC information.

In the following a typical example of an RRC information container is provided:

```

-- *****
--
-- RRC information, to target RNC
--
-- *****
-- RRC Information to target RNC sent either from source RNC or from another RAT

ToTargetRNC-Container ::= CHOICE {
  InterRATHandover          InterRATHandoverInfoWithInterRATCapabilities,
  srncRelocation            SRNC-RelocationInfo,
  extension                 NULL
}

```

The term RRC message is used for the RRC information identified by a choice value, e.g. HANDOVER TO UTRAN COMMAND, INTER RAT HANDOVER INFO. The characteristics and handling defined for these RRC messages to a large extent resemble the RRC messages transferred across the Uu interface. The specification focuses on UE requirements. Hence, RRC messages that originate from/terminate in the UE/ MS are treated in the main clauses (clauses 8, 9, 10) while the other RRC messages are specified in clause 14 of TS 25.331.

As stated before, RRC information containers have been defined to limit the impact of transferring RRC information across other interfaces. Intermediate nodes transparently pass the information carried in such containers; only the originating and terminating entities process the information. This transparency makes the protocols independent. In case there is RRC information on which intermediate nodes need to act, the information elements should be introduced in the corresponding interface protocols. If the information is to be passed on to another target node also, this may result in duplication of information. For RRC information containers the same extension mechanism as defined for RRC messages applies; both critical and non-critical extensions may be added. If the extension would not be defined at RRC information container level, other interface specification would be affected whenever the RRC information would be extended.

In some cases information in containers is exchanged by peer entities that do not speak the same (protocol) language, e.g. a GSM BSC may have to exchange information with a UTRA RNC. For such cases, it has been agreed that the source/sender of the information adapts to the target/receiver, e.g. upon handover to UTRAN the BSS provides RANAP information within a Source to Target RNC transparent container.

NOTE: The handover to UTRAN info is not only transferred from UE, via BSS to target RNC but may also be returned to another BSS, to be forwarded later on to another RNC. To simplify the handling of RRC information in network nodes, it is therefore desirable to align the format of the RRC information used in both directions. The alignment of formats used in the different directions is not considered to violate these general principles, since for this information that is moved forwards and backwards it is difficult to speak of source and target anyhow.

The error handling for RRC information containers that are terminated in network nodes applies the same principles as defined for RRC messages. A network node receiving an invalid RRC information container (unknown, unforeseen or erroneous container) from another network node should return an RRC INFORMATION FAILURE message and include an appropriate cause value within IE "Protocol error cause". Although the return of a failure container is considered desirable, no compelling need has been identified to introduce support for transferring this failure container in R'99 for all concerned interface protocols. In case the interface protocols do not support the failure procedure, the failure may instead be indicated by means of a cause value that is already defined within the interface protocol.

5.1.7.2 Message sequence diagrams

As stated before, most RRC information is carried by means of containers across interfaces other than Uu. The following sequence diagrams illustrate which RRC messages should be included within these RRC information containers used across the different network interfaces. Concerning the contents of RRC messages, i.e. when optional IEs should be included, requirements are specified in TS 25.331 only for the RRC messages originated/terminated in the UE, since the RRC specification focuses on UE requirements.

NOTE: In order to maintain independence between protocols, no requirements are included in the interface protocols that are used to transfer the RRC information.

For each of the different message sequences not only the details on the RRC information transferred are provided, but also deviations from the general principles described in the previous are highlighted. One common deviation from the general principles is that containers are not used for any RRC information transferred across the GSM air interface; in all these cases RRC messages are used instead (mainly for historical reasons).

The following figure illustrates the message sequence for the handover to UTRAN procedure:

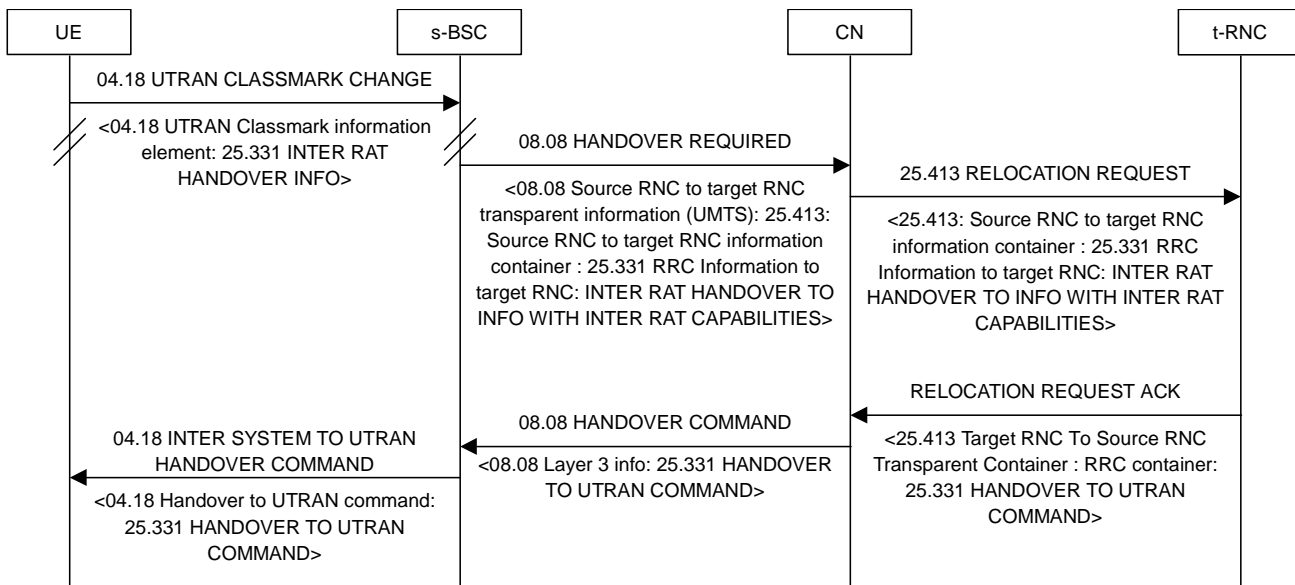

Figure 5.1.7.2-1: Handover to UTRAN, normal flow

As can be seen in the previous figure, the RRC information transfer within the handover to UTRAN procedure deviates from the common principles in the following areas:

- Containers are not used to transfer the HANDOVER TO UTRAN COMMAND message across the Iu and the A-interface.

The following figure illustrates the message sequence for the handover from UTRAN procedure:

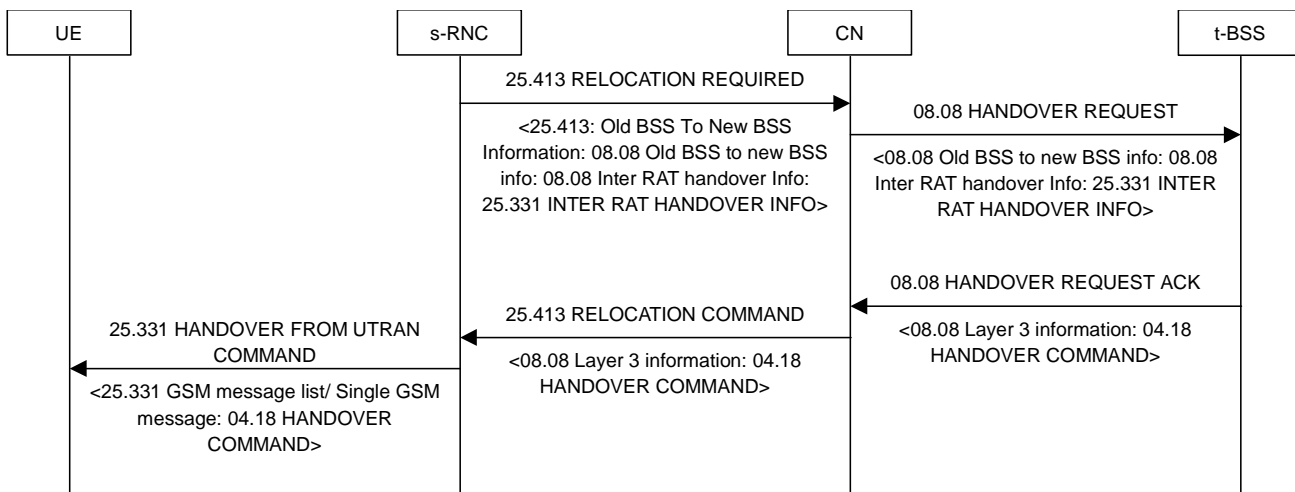

Figure 5.1.7.2-2: Handover from UTRAN, normal flow

As can be seen in the previous figure, the RRC information transfer within the handover from UTRAN procedure deviates from the common principles in the following areas:

- Containers are not used to transfer the INTER RAT HANDOVER INFO message across the Iu and the A-interface.

The following figure illustrates the message sequence for the SRNS relocation procedure:

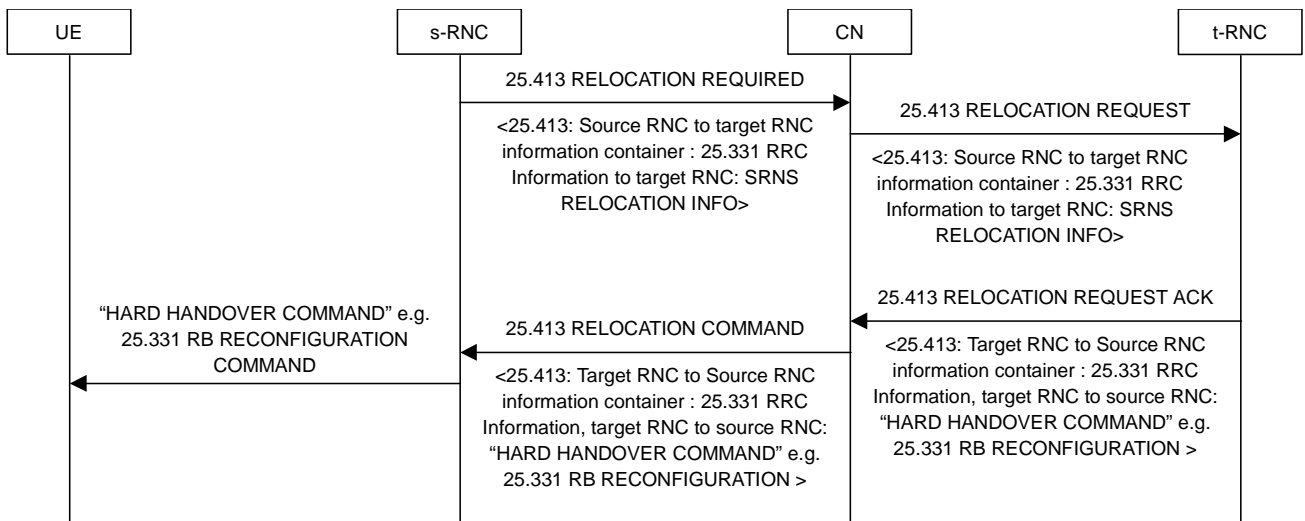

Figure 5.1.7.2-3: SRNS relocation, normal flow

As can be seen in the previous figure, the RRC information transfer within the SRNS relocation procedure does not deviate from the common principles.

The following figure, showing the message sequence for the inter BSC handover, is provided for completeness.

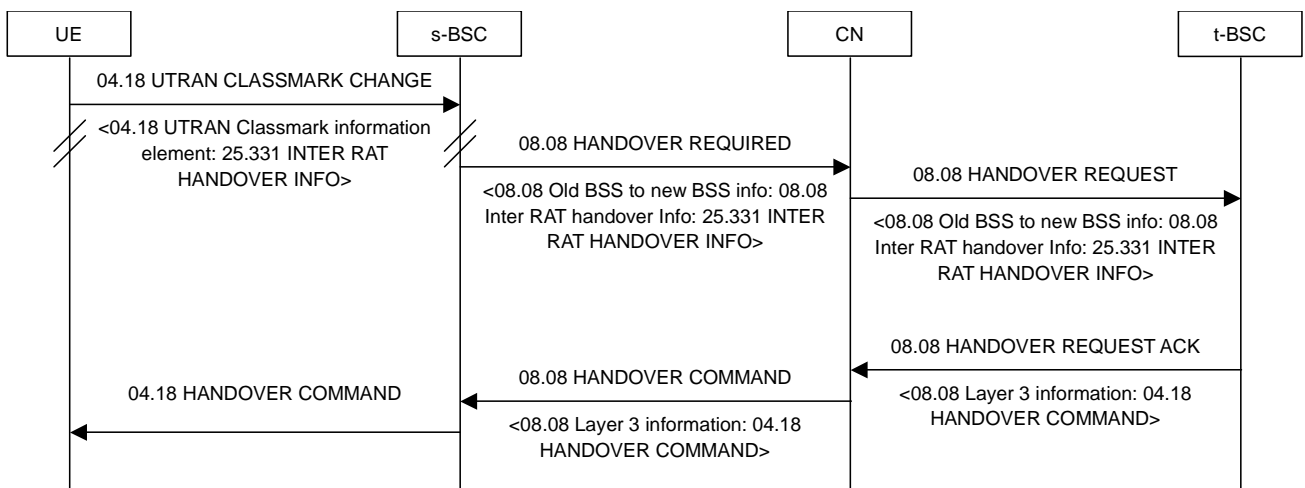

Figure 5.1.7.2-4: Inter BSC handover, normal flow

As can be seen in the previous figure, the RRC information transfer within the inter BSC handover procedure deviates from the common principles in the following areas:

- Containers are not used to transfer the INTER RAT HANDOVER INFO message across the A-interface.

5.1.7.3 General error handling for RRC containers

As indicated in the previous sections, the characteristics and the handling of RRC messages transferred across other interfaces than Uu is the same as that of regular RRC messages. This equally applies for the extension of such messages as well as for the related general error handling. In this section three generic error handling cases are distinguished that have distinct characteristics that are specific to RRC containers.

RRC message sent by UE via another RAT

As for regular messages, only non-critical extensions apply in uplink. Upon not comprehending a non-critical extension, the receiver just ignores this information and processes the other parts as if the not comprehended extension was absent. Hence, it is not applicable to use a RRC FAILURE INFO message in the reverse direction.

For the HANOVER TO UTRAN INFO message, the BSS not only transparently passes the information received from the UE, but also adds information and includes it in an RRC container to be forwarded to the target RNC. For information originated and terminated in a network nodes both critical and non-critical extensions apply. Since critical extensions applies for the information inserted by the BSS, they also apply for the HANOVER TO UTRAN INFO WITH INTER RAT CAPABILITIES message that includes them. The corresponding RRC FAILURE INFO message would be terminated in the BSS.

RRC container information terminated in UE (HANOVER TO UTRAN COMMAND)

In case of a not comprehended critical extension, the UE shall reject the handover and return a failure message towards the BSC. The RRC procedure also states that a RRC FAILURE INFO message should be included, depending on system specific procedures. The (network) interface signalling procedures do not support the transfer of this RRC message which is not a problem since the extension mechanism does not require it. Instead a cause value may be returned.

If the INTER SYSTEM TO UTRAN HANOVER FAILURE message used across the GSM air interface would support the transfer of the RRC FAILURE INFO message, the RRC message would not be passed beyond the source BSC since there are no further signalling procedures. However, when needed, this failure information may be transferred to the t-RNC in a subsequent attempt to perform handover for the same UE and to the same RNC. To accommodate this, the HANOVER TO UTRAN INFO message may include the failure information. This is illustrated in the following figure:

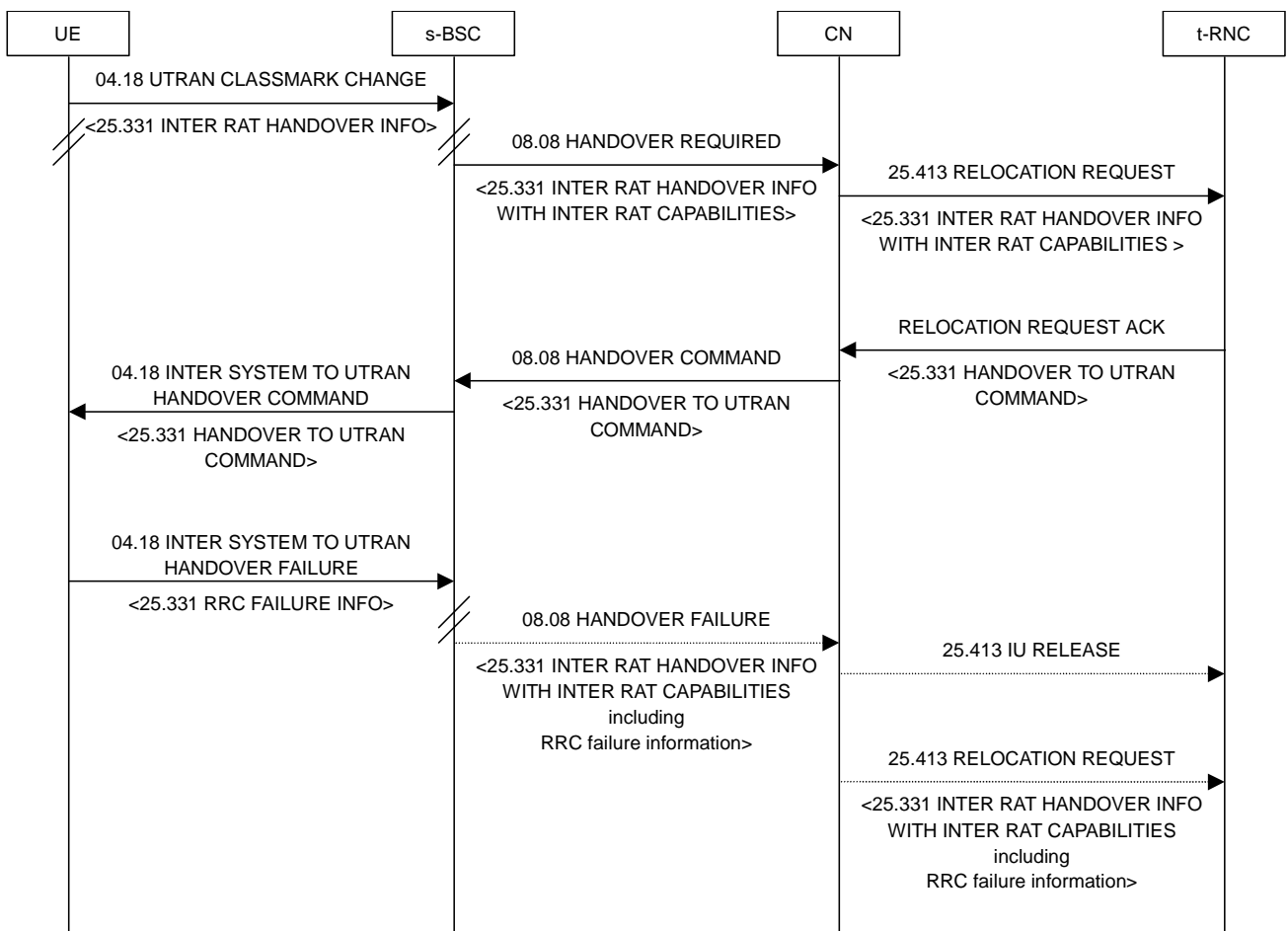

Figure 5.1.7.3-1: Handover to UTRAN, failure due to critical extension not supported by UE

RRC container information terminated in network (SRNS relocation info & commands)

This case is basically the same as for the handover to UTRAN command, although in this case the container is really terminated by the s-RNC. Nevertheless, in case the handover command includes a critical extension that the UE does not comprehend, it will notify the s-RNC by means of the applicable failure message including IE "Protocol error cause" set to "Message extension not comprehended". If a failure notification is desired towards the t-RNC upon a

subsequent attempt to perform the handover, the s-RNC has to generate this based on the received protocol error information.

6 Admission Control

6.1 Introduction

In CDMA networks the 'soft capacity' concept applies: each new call increases the interference level of all other ongoing calls, affecting their quality. Therefore it is very important to control the access to the network in a suitable way (Call Admission Control - CAC).

6.2 Examples of CAC strategies

Principle 1: Admission Control is performed according to the type of required QoS.

"Type of service" is to be understood as an implementation specific category derived from standardised QoS parameters.

The following table illustrates this concept:

Table 6-1: (*) Premium service: Low delay, high priority. () Assured Service: A minimum rate below the mean rate is guaranteed, service may use more bandwidth if available, medium priority. (***) Best Effort: No guaranteed QoS, low priority**

Service	Domain	Transport Channel	Type of service	CAC performed
Voice	CS	DCH	Premium (*)	YES
	IP	DCH	Premium (*)	YES
Web	IP	DSCH	Assured Service (**)	YES
	IP	DSCH	Best Effort (***)	NO

Other mappings are possible like for instance:

PSTN domain: Premium service, IP domain: Best Effort.

Principle 2: Admission Control is performed according to the current system load and the required service.

The call should be blocked if none of the suitable cells can efficiently provide the service required by the UE at call set up (i.e., if, considering the current load of the suitable cells, the required service is likely to increase the interference level to an unacceptable value). This would ensure that the UE avoids wasting power affecting the quality of other communications.

In this case, the network can initiate a re-negotiation of resources of the on-going calls in order to reduce the traffic load.

Assumption: Admission Control is performed by CRNC under request from SRNC.

6.3 Scenarios

6.3.1 CAC performed in SRNC

Figure 6-1 is to be taken as an example. It describes the general scheme that involves Admission Control when no Iur is used and the CRNC takes the role of SRNC.

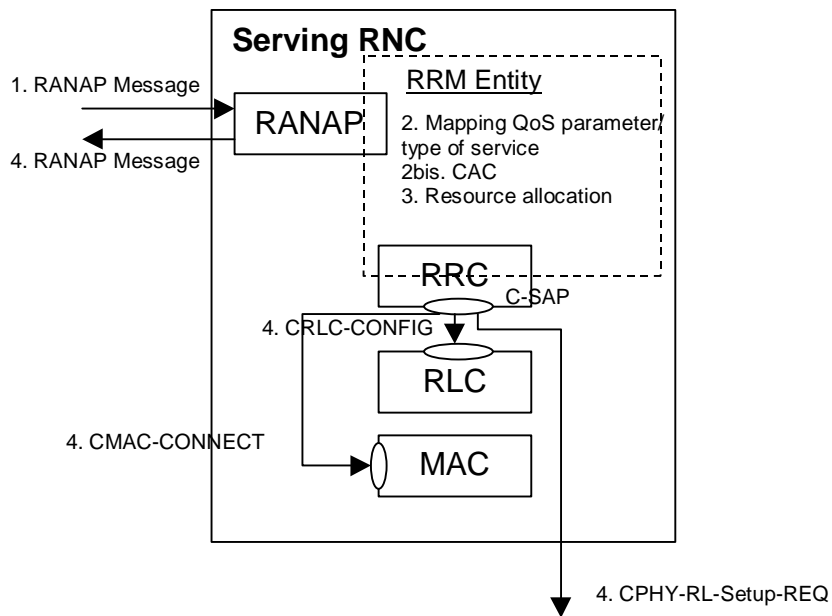

Figure 6-1: This model shows how standardised RANAP and RRC layers are involved in the CAC process

1. CN requests SRNC for establishing a RAB indicating QoS parameters.
2. According to QoS parameters the requested service is assigned a type of service. CAC is performed according to the type of service.
3. Resources are allocated according to the result of CAC.
4. Acknowledgement is sent back to CN according to the result of CAC. Sublayers are configured accordingly.

Steps 2 to 4 may also be triggered by SRNC for reconfiguration purpose within the SRNC (handovers intra-RNC, channels reconfigurations, location updates).

6.3.2 CAC performed in DRNC

If a radio link is to be set up in a node-B controlled by another RNC than the SRNC a request to establish the radio link is sent from the SRNC to the DRNC. CAC is always performed in the CRNC, and if Iur is to be used as in this example, CAC is performed within the DRNC.

6.3.2.1 Case of DCH

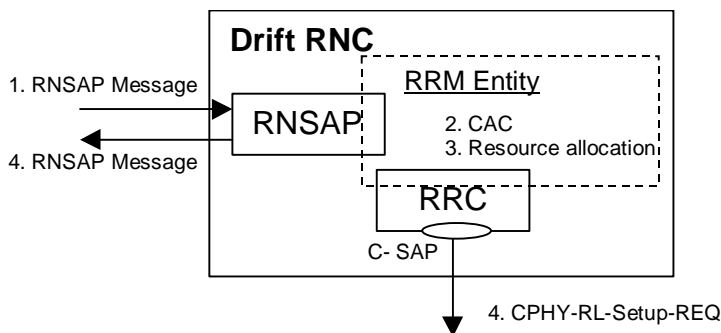

Figure 6-2: This model shows how standardised RNSAP and RRC layers are involved in the CAC process

1. SRNC requests DRNC for establishing a Radio Link, indicating DCH characteristics. These implicitly contain all QoS requirements and are enough as inputs to the CAC algorithm.
2. CAC is performed according to DCH characteristics.
3. Resources are allocated according to the result of CAC.
4. Acknowledgement is sent back to the SRNC according to the result of CAC.

6.3.2.2 Case of Common Transport Channels

When transmitting on Common Transport Channels a UE may camp on a new cell managed by a new RNC. SRNC is notified by UE through RRC messages that connection will be set up through a new DRNC. Subsequently SRNC initiates connection through new DRNC.

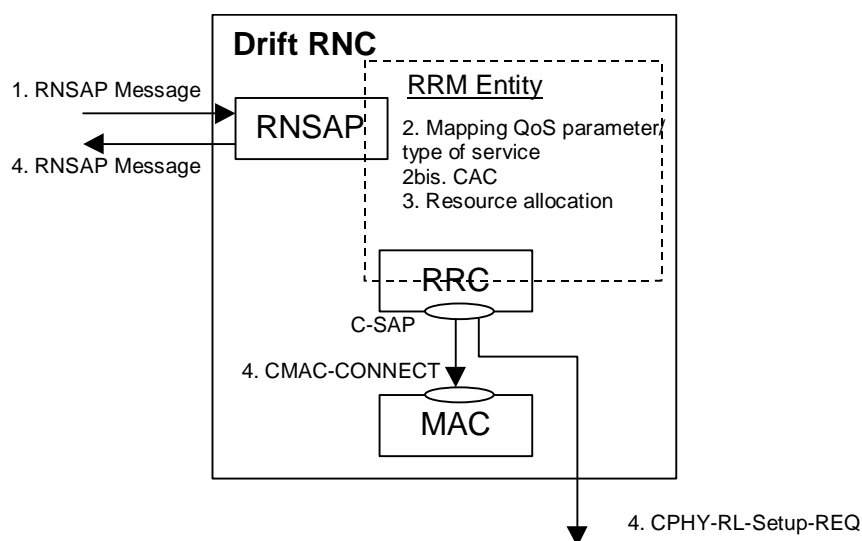

Figure 6-3: This model shows how standardised RNSAP and RRC layers are involved in the CAC process

1. SRNC requests DRNC for establishing a Radio Link. A RNSAP message contains the QoS parameters and the type of Common Transport Channel to be used.
2. According to QoS parameters the requested service is assigned a type of service. CAC is performed according to the type of service and to the type of Common Transport Channel requested by SRNC.
3. Resources are allocated according to the result of CAC.
4. Acknowledgement is sent back to the SRNC according to the result of CAC. L1 and MAC are configured accordingly by RRC layer.

7 Radio Bearer Control

7.1 Usage of Radio Bearer Control procedures

Radio Bearer (RB) Control procedures are used to control the UE and system resources. This subclause explains how the system works with respect to these procedures and how e.g. traffic volume measurements could trigger these procedures.

7.1.1 Examples of Radio Bearer Setup

In order to set up a new RB, a RRC connection must have been established, and some NAS negotiation has been performed. The RB Setup message comes from UTRAN and depending on the requirement of the service a common or a dedicated transport channel could be used. In the example below the UE is using a common transport channel for the RRC connection and stays on the common transport channel after the RB setup.

However, transport channel parameters such as transport formats and transport format combinations are configured not only for the used common transport channel, but also for dedicated transport channel for future use.

All physical parameters are the same before and after the RB setup in this example.

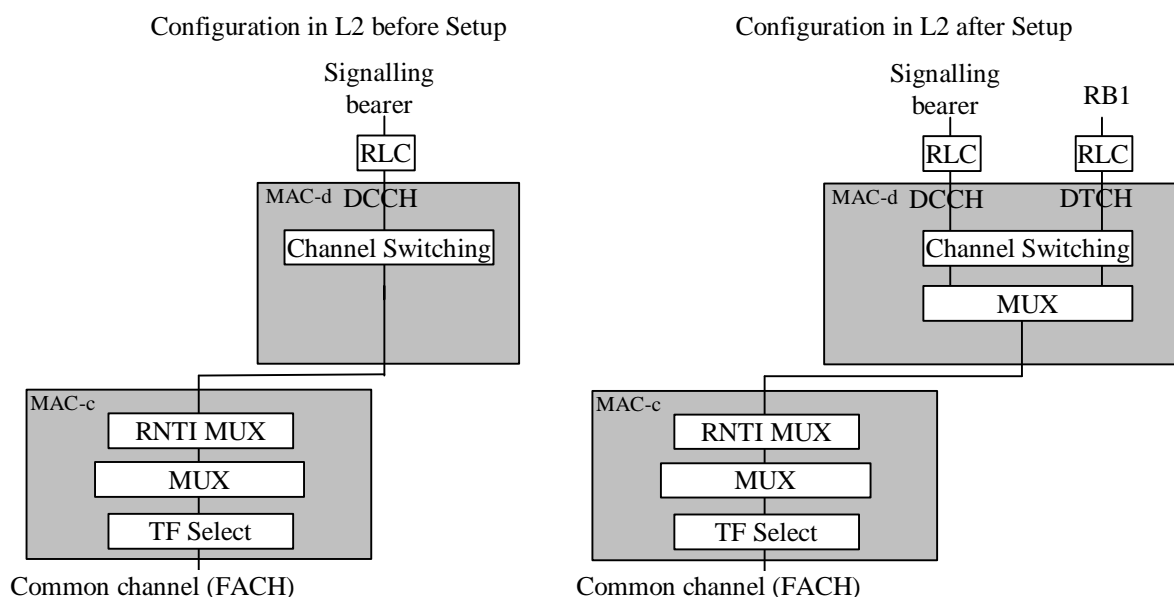

Figure 7-1: Configuration of L2 in the UTRAN DL before and after the RB setup

Detailed examples of messages exchange and parameters used are reported in Annex B, Subclause B.1.

7.1.2 Examples of Physical Channel Reconfiguration

This RRC procedure is used to reconfigure the Physical channel and can by that also trigger Transport channel type switching.

Below several examples of Physical Channel reconfigurations are shown, triggered by different amount of UL or DL data.

7.1.2.1 Increased UL data, with switch from RACH/FACH to DCH/DCH

A UE that is in the RACH/FACH substate can transmit a small amount of user data using the common transport channels. For larger amounts it is more appropriate to use a dedicated transport channel. Since each UE doesn't know the total load situation in the system UTRAN decides if a UE should use common transport channels or a dedicated transport channel.

The monitoring of UL capacity need is handled by a UTRAN configured measurement in the UE. When the Transport Channel Traffic Volume (equivalent to the total sum of Buffer Occupancies of logical channels mapped onto the transport channel) in the UL increases over a certain threshold the UE sends a measurement report to UTRAN. This threshold to trigger the report is normally given in System Information, but UTRAN can also control the threshold in a UE dedicated Measurement Control message.

Since, UTRAN has the current status of the total UL need it can decide which UEs that should be switched to a dedicated transport channel. If UTRAN has pre-configured the transport formats and transport format combinations to be used on the dedicated transport channel for the UE, a Physical channel reconfiguration procedure could be used to assign dedicated physical resources.

The spreading factor for the physical channels assigned then give, which transport format combinations that are allowed to use.

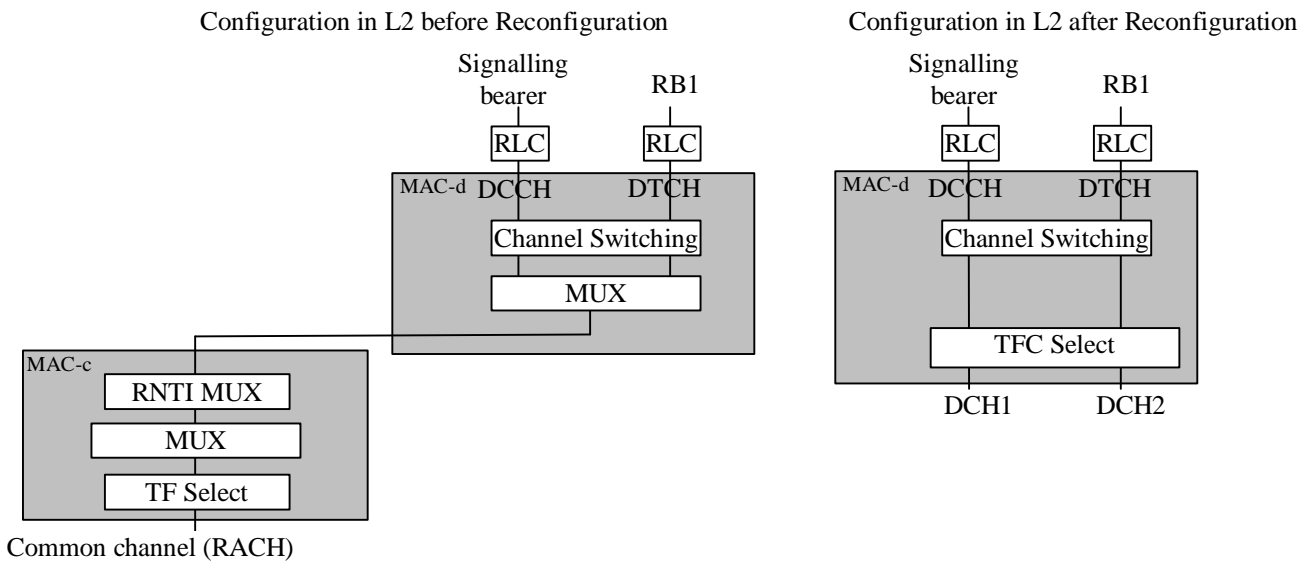

Figure 7-2: Configuration in the UTRAN UL before and after the Physical channel reconfiguration

Detailed examples of messages exchange and parameters used is reported in Annex B, Subclause B.2.1.

7.1.2.2 Increased DL data, no Transport channel type switching

If the Transport Channel Traffic Volume increases above a certain threshold in the network the UTRAN can do a physical channel reconfiguration. Here the UE uses a dedicated transport channel, and this procedure is used to decrease the spreading factor of the physical dedicated channel. This way this variable bitrate service increases the throughput on the downlink.

A variable bitrate service that has large traffic variations should have transport formats and transport format combinations defined for lower spreading factors than currently used on the physical channel. Then after the physical channel reconfiguration that lowers the spreading factors these transport formats and transport format combinations could be used to increase the throughput for this user.

However, if the transport formats and transport format combinations have not been previously defined to support a lower spreading factor, a Transport channel reconfiguration must be used instead in order to get any increased throughput.

Only downlink physical parameters are changed here since the uplink in this scenario doesn't need to increase its capacity.

Detailed examples of messages exchange and parameters used is reported in Annex B, Subclause B.2.2.

7.1.2.3 Decrease DL data, no Transport channel type switching

Since downlink channelisation codes are a scarce resource a UE with a too high, allocated gross bit rate (low spreading factor) must be reconfigured and use a more appropriate channelisation code (with higher spreading factor). This could be triggered by a threshold for the Transport Channel Traffic Volume and some inactivity timer, i.e. that the Transport Channel Traffic Volume stays a certain time below this threshold.

After the physical channel has been reconfigured, some of the transport formats and transport format combinations that require a low SF can not be used. However, these are stored and could be used if the physical channel is reconfigured later to use a lower spreading factor.

Detailed examples of messages exchange and parameters used is reported in Annex B, Subclause B.2.3.

7.1.2.4 Decreased UL data, with switch from DCH/DCH to RACH/FACH

In the network the UE traffic can be evaluated and the network can observe which transport format combinations that are used in the UL. The network could also simply look at how much data the UE transmits or use measurement reports.

If the UE is transmitting a low amount of data in the uplink and there is little traffic in the downlink, this could trigger a switch from a dedicated transport channel to a common transport channel. Depending on if the already defined RACH/FACH configuration is possible/preferred in the cell that the UE will be in after the switch, a Transport channel reconfiguration or a Physical channel reconfiguration procedure is used.

In the example below the UE has stayed in cells with a similar RACH and FACH configuration when using a dedicated transport channel. Therefore, the Physical channel reconfiguration procedure can be used. In 8.1.3.2 this is not the case and a Transport channel reconfiguration is used instead.

After the UE has performed the transport channel type switch to the RACH/FACH substate, all transport channel parameters such as transport formats for the dedicated transport channel are stored. The same configuration of the dedicated transport channels could then be reused if the UE switches back to the DCH/DCH substate.

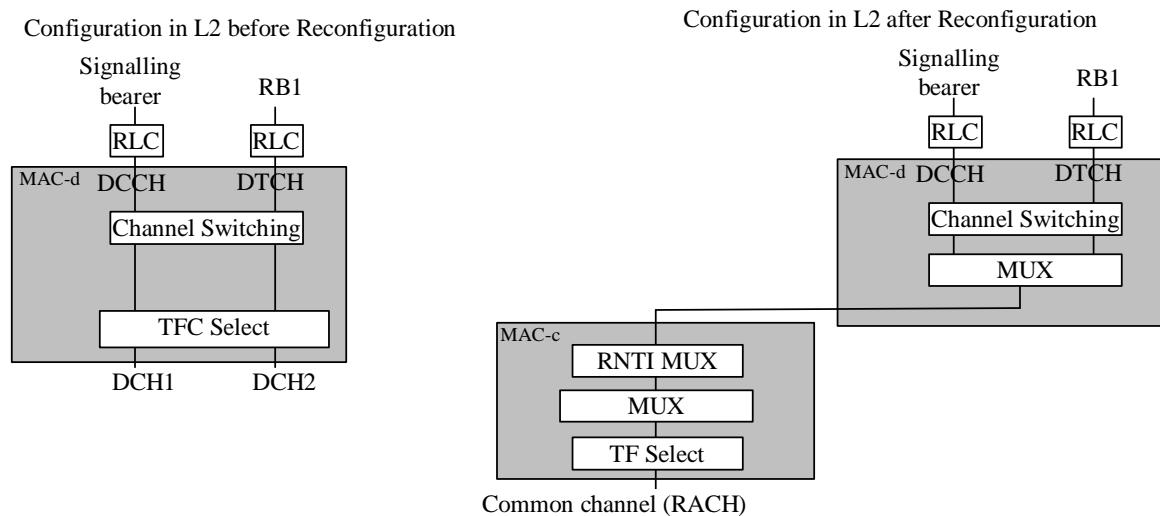

Figure 7-3: Configuration in the UTRAN UL before and after the Physical channel reconfiguration

Detailed examples of messages exchange and parameters used is reported in Annex B, Subclause B.2.4.

7.1.3 Examples of Transport Channel Reconfiguration

This RRC procedure is used to reconfigure the transport channel and the physical channels, and can by that also trigger Transport channel type switching.

Below, several examples of Transport channel reconfiguration are shown, triggered by different amount of UL or DL data.

7.1.3.1 Increased UL data, with no transport channel type switching

When a UE Transport Channel Traffic Volume increases above a certain threshold, a measurement report is sent to UTRAN. Depending on the overall load situation in the network the UTRAN could decide to increase the uplink capacity for a UE. Since every UE has its "own" code tree, there is no shortage of UL codes with a low spreading factor, and all UEs can have a low spreading factor code allocated.

Therefore, instead of channelisation code assignment as used in the DL, load control in the UL is handled by the allowed transport formats and transport format combinations for each UE. To increase the throughput for a UE in the uplink, UTRAN could send a Transport channel reconfiguration or a TFC Control message.

Here a Transport channel reconfiguration is used. Although, the TFC Control procedure is believed to require less signalling it can only restrict or remove restrictions of the assigned transport format combinations and that may not

always be enough. If a reconfiguration of the actual transport formats or transport format combinations is required, the Transport channel reconfiguration procedure must be used instead.

In the example below, the UE is allowed to send more data in the UL when on dedicated transport channel, although the common transport channel configuration is still the same. To make use of the new transport format combinations the physical channel must also be reconfigured to allow a lower spreading factor.

Detailed examples of messages exchange and parameters used is reported in Annex B, Subclause B.3.1.

7.1.3.2 Decreased DL data, with switch from DCH/DCH to RACH/FACH

In the network the downlink traffic to a UE can be evaluated and the network can observe which transport format combinations that are used.

If a low amount of data is sent to the UE in the downlink and there is little traffic in the uplink, this could trigger a switch from a dedicated transport channel to a common transport channel. Depending on if the already defined RACH/FACH configuration is possible/preferred in the cell that the UE will be connected to after the switch, a Transport channel reconfiguration or a Physical channel reconfiguration procedure is used. In this example the UE has moved to cells with a different FACH or RACH configuration when using a dedicated transport channel, so a Transport channel reconfiguration procedure must be used.

When the UE do the switch from a dedicated transport to a common transport channel the RACH and FACH transport channels are reconfigured with new transport formats if the old configuration is not supported in the new cell. What physical common channel to be used is pointed out in the physical channel parameters.

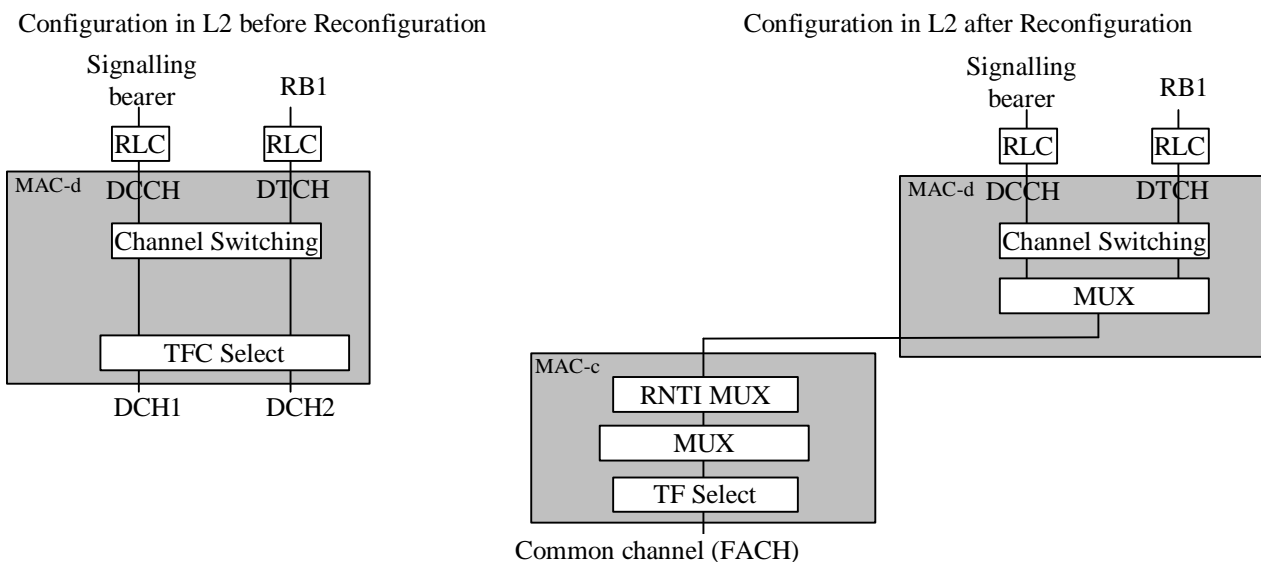

Figure 7-4: Configuration in the UTRAN DL before and after the Transport channel reconfiguration

Detailed examples of messages exchange and parameters used is reported in Annex B, Subclause B.3.2.

7.1.4 Examples of Radio Bearer Reconfiguration

A RB reconfiguration is here used to change how the MUX in MAC of logical channels belonging to different RBs is configured.

The RB Reconfiguration message includes parameters for the new multiplexing configuration in MAC, and a reconfiguration of the Transport channel that both RBs will use. The old obsolete transport channel is also removed (here DCH3 is removed). All other parameters associated with the RBs are unchanged.

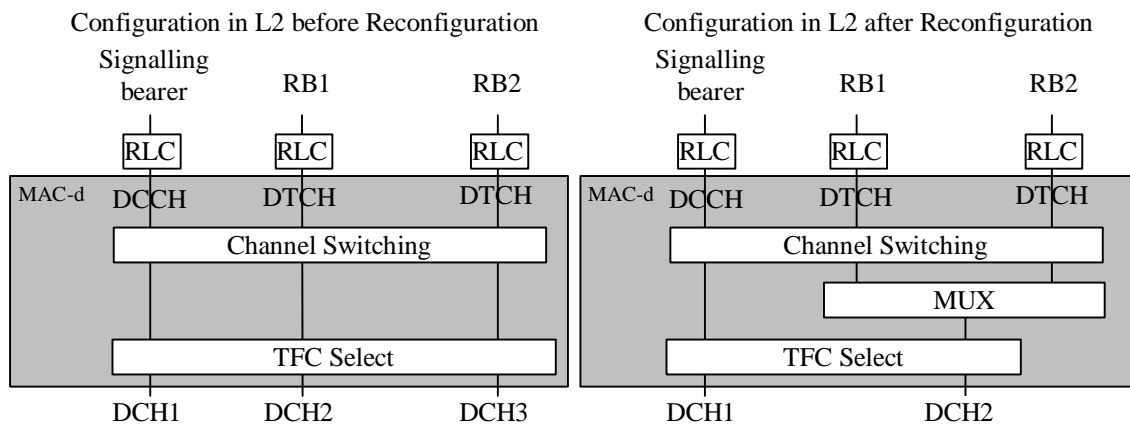

Figure 7-5: Configuration in the UTRAN DL before and after the RB reconfiguration

Detailed examples of messages exchange and parameters used is reported in Annex B, Subclause B.4.

8 Dynamic Resource Allocation

8.1 Code Allocation Strategies for FDD mode

8.1.1 Introduction

Code allocation deals with the problem how different codes are allocated to different connections. The channelisation codes used for spreading are Orthogonal Variable Spreading Factor (OVSF) codes that preserve the orthogonality between a user's physical channel. The OVSF code is shown in the following figure:

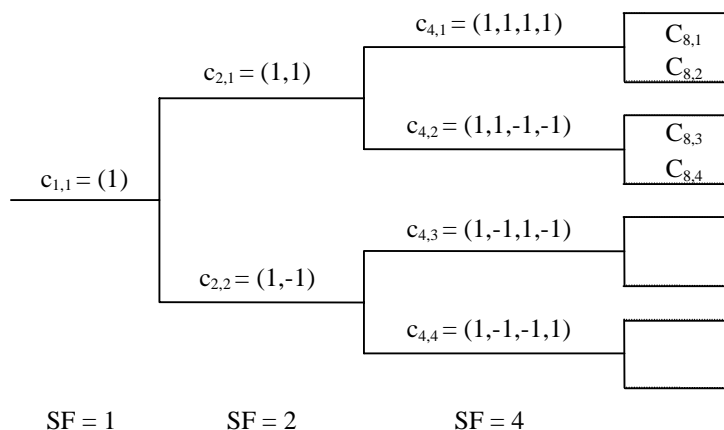

Figure 8-1: OVFS Code Tree

Each level in the code tree is described as $C_{SF,code\ number}$, where the spreading factor (SF) is ranging from 4 to 512 for the chip rate of 3.84 Mcps. A code can be assigned to a UE if and only if no other code on the path from the specific code to the root of the tree or in the sub-tree below the specific code is assigned. For example, a random assignment of large-SF codes to low data rate channels may preclude a large number of small-SF codes. It inefficiently limits the number of remaining codes that could be used by other users. On the contrary, it will be advantageous to assign codes to low data rate users in such a way as to minimise the number of unavailable small-SF codes. Moreover, it is expected to be advantageous to assign users operative at a particular data rate to closely related codes so as to minimise the number of small-SF codes being marked as unavailable. A proper code allocation algorithm is used to find the "closely related code" to prevent the BS from running out of codes and to utilise the system resource effectively. The so-called "closely related code" would be obtained via a code allocation strategy according to the available codes of the BS and the capability of the UE.

8.1.2 Criteria for Code Allocation

OVSF codes are valuable resources in CDMA system. The objective of the code allocation is to support as many users as possible with less complexity.

In the application, different UEs may request for different types of services with different transmission rates. Each UE may have the capability to use more than one code to support different data rates. The following criteria can be envisaged:

1. **Utilisation.** The utilisation is defined as the ratio of assigned bandwidth and overall bandwidth. A code allocation scheme that preserves more small-SF codes has a higher chance to provide a higher utilisation. For example, $C_{4,1}$ and $(C_{8,1}, C_{8,3})$ are the available codes of a BS resulting from two different code allocation schemes. $C_{4,1}$ (which is equivalent to codes $C_{8,1}$ and $C_{8,2}$) can support a symbol rate up to 960 kbps. $(C_{8,1}, C_{8,3})$ can also support the same symbol rate as $C_{4,1}$ does. However, only $C_{4,1}$ can support the UE that requests for 960 kbps symbol rate using only one code (due to the capability of the handset). In this example, the former has more small-SF codes than the latter, thus, it will result in a better utilisation.
2. **Complexity.** The more codes are used, the complexity of the system will be increased. In some cases, there are more than one way to meet the first criterion mentioned above. For example, one UE can use either one code ($C_{4,1}$) or two codes ($C_{8,1}$ and $C_{8,2}$) as the channelisation codes. Under this situation, the code allocation scheme that requires the least codes should be chosen.

8.1.3 Example of code Allocation Strategies

An example of code allocation algorithm based on the two above criteria is presented in the following. In order to indicate the available OVSF codes of the system, an order pair C , called a code-word, is introduced. Let $C=(a_1, a_2, a_3, a_4, a_5, a_6, a_7)$ denote the available codes for SF=(4,8,16,32,64,128,256), respectively, where $a_1 \leq 4$, $a_2 \leq 8$, $a_3 \leq 16$, $a_4 \leq 32$, $a_5 \leq 64$, $a_6 \leq 128$, and $a_7 \leq 256$. The total data rate (*i.e.* it has been normalised by a data rate of an OVSF code with SF=256) supported by C is called the weight W and can be obtained by:

$$W(C) = a_1 \cdot 2^6 + a_2 \cdot 2^5 + a_3 \cdot 2^4 + a_4 \cdot 2^3 + a_5 \cdot 2^2 + a_6 \cdot 2^1 + a_7.$$

$S(n)$ is a set of code-words that can support a total data rate up to n and it can be obtained by:

$$S(n) = \{C | W(C) = n, \forall C\}.$$

The number of codes $N(C)$ required for transmitting a code-word C can be calculated by:

$$N(C) = a_1 + a_2 + a_3 + a_4 + a_5 + a_6 + a_7.$$

Consider a UE which requests for a data rate of n . Define $C_r=(a_1, a_2, a_3, a_4, a_5, a_6, a_7)$ and $C_t=(a_1, a_2, a_3, a_4, a_5, a_6, a_7)$ are the code-words of the system before and after code allocation, respectively. For $W(C_r)=m$, we can find that $W(C_t)=W(C_r)-n=m-n$.

For example, $m=13$ and $n=6$ $C_r=(0,0,0,0,2,1,3)$.

The possible candidates for the allocated codes is one of the element of set $S(6)$, where:

$$S(6) = \{(0,0,0,0,0,0,6), (0,0,0,0,0,1,4), (0,0,0,0,0,2,2), (0,0,0,0,1,0,2), (0,0,0,0,0,3,0), (0,0,0,0,1,1,0)\} \\ \equiv \{C1, C2, C3, C4, C5, C6\}.$$

Thus, the possible code-words of the system after allocating the codes to the UE can be obtained by

$$T(7) = \{C_r - C1, C_r - C2, C_r - C3, C_r - C4, C_r - C5, C_r - C6\} \\ = \{(0,0,0,0,1,1,1), (0,0,0,0,1,1,1), (0,0,0,0,1,1,1), (0,0,0,0,1,1,1), (0,0,0,0,1,0,3), (0,0,0,0,1,0,3)\}.$$

According to the first criterion, $(0,0,0,0,1,1,1)$ is the preferred code-word (denoted as C_{opt}) after the allocation and $C1$, $C2$, $C3$, and $C4$ are possible candidates for the allocated code-words. The number of codes required for these code-words are $N(C1)=6$, $N(C2)=5$, $N(C3)=4$, and $N(C4)=3$. According to the second criterion, $C4$ would be chosen because it uses the least codes.

In general, it is not feasible to examine all of the possible code-words from the set $S(n)$ as illustrated above, especially for a large value of n . It is also a time-consuming process to find $T(m-n)$ by subtraction of the code-words individually. Here, a fast code allocation algorithm can be used to find the preferred code-word C_{opt} , where:

$$C_{opt} = C_r - (C_r - (0,0,0,0,0,0,n)).$$

In the above example, $C_r = (0,0,0,0,2,1,3)$, $n=6$, and $C_r - (0,0,0,0,0,0,6) = (0,0,0,0,1,1,1)$. Therefore, $C_{opt} = (0,0,0,0,2,1,3) - (0,0,0,0,1,1,1) = (0,0,0,0,1,0,2) = C_4$.

In a particular implementation of the code allocation algorithm, the BS could maintain a list of available codes. When UE requests for channel codes, the number of codes of different SF required supporting the required data rate could be identified by the code allocation algorithm. Upon identification of codes of suitable SFs, the BS will assign the codes from the table.

In the real system, the MS can use only k codes for transmitting data. In some cases, the fast code allocation algorithm cannot be applied. Therefore, two situations may occur:

Situation I. $N(C_{opt}) \leq k$:

- The procedure described above can be used and the allocated code-word $C = C_{opt}$.

Situation II. $N(C_{opt}) > k$:

- In this situation, the fast code allocation algorithm may not be applied because the MS can not support as many codes as that determined by C_{opt} . In this case, the allocated code-word C is the one that $N(C)=k$. However, the new call requests will be blocked if the MS can not support the requested data rate with the given number of codes k .

8.1.4 PDSCH code management

In this subclause two typical examples are given of the way in which the UTRAN might configure usage of the DSCH.

Where the DSCH is supported the information provided on TFCI(field 2) has to enable the UE to look up both the TFC used on the DSCH CCTrCH as well as the PDSCH channelisation code. Hence this subclause also provides guidance on how to use the various options provided in the RRC protocol for signalling this mapping table.

PDSCH code management is simplified if a bearer is configured such that in any one TTI it is possible to select codes for transmission toward a single user from a wide range of the available set of PDSCH codes. However, since the length of the TFCI(field 2) is limited this can mean that the number of possible transport format combinations that can be used for this user at a given spreading factor is limited. In Table 8-1 an example of a possible mapping table is shown, where as discussed the bearer has been configured to give the UTRAN a high degree of flexibility in code assignment but with a restricted number of TFC options per spreading factor. In the example the TFCI (field 2) is assumed to be 5 bits long, the PDSCH code sub-tree is 5 spreading factors deep and the UTRAN allows only one possible TFC per spreading factor.

Table 8-1: Example of a table, which the UE must build to map TFCI (field 2) to CTFC and PDSCH channelisation code

TFCI (field 2)	CTFC	PDSCH Channelisation code
0	α	SF=128, Code number = 0
1	α	SF=128, Code number = 1
2	α	SF=128, Code number = 2
3	α	SF=128, Code number = 3
:	:	:
15	α	SF=128, Code number = 15
16	β	SF=64, Code number = 0
17	β	
:	:	:
23	β	SF=64, Code number = 7
24	χ	SF=32, Code number = 0
:	:	:
27	χ	SF=32, Code number = 3
28	δ	SF=16, Code number = 0
29	δ	SF=16, Code number = 1
30	ϵ	SF=8, Code number = 0

In order to signal this mapping table it is possible to make use of 'for' loops in order to reduce the amount of signalling information that has to be transferred in order to describe the mapping, this would be done as follows:

for TFCI2 range 0 to 15:

Channelisation codes have SF=128, and the code numbers corresponding to the TFCI2 values range from 0 to 15.

for TFCI2 range 16 to 23:

Channelisation codes have SF=64, and the code numbers corresponding to the TFCI2 values range from 0 to 7.

:

:

for TFCI2 range 0 to 15:

CTFC = α

for TFCI2 range 16 to 23:

CTFC = β

:

:

This method for signalling the mapping table is possible by using the 'code range' CHOICE in the RRC 'PDSCH code mapping' IE and by using the 'TFCI range' CHOICE in the RRC 'Transport format combination set' IE.

It is also possible that under some circumstances an operator may prefer or need to configure the bearer such that there are only a restricted set of PDSCH codes which may be used for a certain UE but where a large number of possible transport format combinations must be supported on each code. This approach might be taken if for example a large number of services are being multiplexed toward the user. In this case, given the limited number of TFCI (field 2) bits the only option may be to restrict the range of PDSCH codes that can be assigned to the UE. An example of the mapping table for this case is shown in Table 2, the 5 bits of TFCI(field2) in this case being used to differentiate between different TFCs.

Table 8-2: Another example of the table which the UE must build to map TFCI to CTFC and channelisation code

TFCI (field 2)	CTFC	PDSCH Channelisation code
0	α	SF=32, Code number = 0
1	β	SF=32, Code number = 0
2	γ	SF=32, Code number = 0
3	δ	SF=32, Code number = 0
4	ϵ	SF=32, Code number = 0
5	ζ	SF=32, Code number = 0
:	:	:
31	η	SF=32, Code number = 0

In this case in order to signal the mapping between TFCI (field 2) and CTFC it is most efficient to use explicit signalling, i.e. to have the CTFC identified individually for each possible value of TFCI(field 2). With regards to identifying the mapping between TFCI(field 2) and the channelisation code, it is on this occasion most efficient to identify the range of TFCI(field2) values for which the PDSCH channelisation code should be applied. This method for signalling the mapping table is possible by using the 'TFCI range' CHOICE in the RRC 'PDSCH code mapping' IE and by using the 'Explicit' CHOICE in the RRC 'Transport format combination set' IE.

8.2 DCA (TDD)

The purpose of DCA is on one side the limitation of the interference (keeping required QoS) and on the other side to maximise the system capacity due to minimising reuse distance.

In order to save battery life time, a UE in idle mode does not perform and report measurements for DCA. ISCP measurements can be started at call establishment. UE TS ISCP measurements are reportable in CELL_DCH state and limited to the current serving cell also in CELL_FACH state.

The channel allocation algorithm will be a distributed, interference adapted approach implemented on network side in the RNC base on local signal strength measurements performed in the UE and the Node B. A priori knowledge about other used channels in the vicinity can be implicitly used without additional signalling traffic.

8.2.1 Channel Allocation

For the UTRA-TDD mode a physical channel is characterised by a combination of its carrier frequency, time slot, and spreading code as explained in the clause on the physical channel structure.

Channel allocation covers both:

- resource allocation to cells (slow DCA);
- resource allocation to bearer services (fast DCA).

8.2.1.1 Resource allocation to cells (slow DCA)

Channel allocation to cells follows the rules below:

- A reuse one cluster is used in the frequency domain. In terms of an interference-free DCA strategy a timeslot-to-cell assignment is performed, resulting in a time slot clustering. A reuse one cluster in frequency domain does not need frequency planning. If there is more than one carrier available for a single operator also other frequency reuse patterns >1 are possible.
- Any specific time slot within the TDD frame is available either for uplink or downlink transmission. UL/DL resources allocation is thus able to adapt itself to time varying asymmetric traffic.
- In order to accommodate the traffic load in the various cells the assignment of the timeslots (both UL and DL) to the cells is dynamically (on a coarse time scale) rearranged (slow DCA) taking into account that strongly interfering cells use different timeslots. Thus resources allocated to adjacent cells may also overlap depending on the interference situation.

- Due to idle periods between successive received and transmitted bursts, UEs can provide the network with interference measurements in time slots different from the one currently used. The availability of such information enables the operator to implement the DCA algorithm suited to the network.
- For instance, the prioritised assignment of time slots based on interference measurements results in a clustering in the time domain and in parallel takes into account the demands on locally different traffic loads within the network.

8.2.1.2 Resource allocation to bearer services (fast DCA)

Fast channel allocation refers to the allocation of one or multiple physical channels to any bearer service Resource units (RUs) are acquired (and released) according to a cell-related preference list derived from the slow DCA scheme.

1. The following principles hold for fast channel allocation: The basic RU used for channel allocation is one code / timeslot / (frequency).
2. Multirate services are achieved by pooling of resource units. This can be made both in the code domain (pooling of multiple codes within one timeslot = **multicode** operation) and time domain (pooling of multiple timeslots within one frame = **multislot** operation). Additionally, any combination of both is possible. Simulation results reported in Appendix A, recommend that the DCA prefers code pooling, over time slot pooling, for UDD packet data; the use of code pooling in fact results in lower number of unsatisfied users.
3. Since the maximal number of codes per time slot in UL/DL depends on several physical circumstances like, channel characteristics, environments, etc. (see description of physical layer) and whether additional techniques to further enhance capacity are applied (for example smart antennas), the DCA algorithm has to be independent of this number. Additionally, time-hopping can be used to average inter-cell interference in case of low-medium bit rate users.
4. Channel allocation differentiates between RT and NRT bearer services:
 - RT services: Channels remain allocated for the whole duration the bearer service is established. The allocated resources may change because of a channel reallocation procedure (e.g. VBR).
 - NRT services: Channels are allocated for the period of the transmission of a dedicated data packet only UDD channel allocation is performed using 'best effort strategy', i.e. resources available for NRT services are distributed to all admitted NRT services with pending transmission requests. The number of channels allocated for any NRT service is variable and depends at least on the number of current available resources and the number of NRT services attempting for packet transmission simultaneously. Additionally, prioritisation of admitted NRT services is possible.
5. Channel reallocation procedures (intra-cell handover) can be triggered for many reasons:
 - To cope with varying interference conditions.
 - In case of high rate RT services (i.e. services requiring multiple resource units) a 'channel reshuffling procedure' is required to prevent a fragmentation of the allocated codes over to many timeslots. This is achieved by freeing the least loaded timeslots (timeslots with minimum used codes) by performing a channel reallocation procedure.
 - When using smart antennas, channel reallocation is useful to keep spatially separated the different users in the same timeslot.

8.2.2 Measurements Reports from UE to the UTRAN

While in active mode the DCA needs measurements for the reshuffling procedure (intra-cell handover). The specification of the measurements to be performed is contained in Section 7.4 in [3]. In this subclause the relevant measurement reports are presented:

- Pathloss of a sub-set of cells (pathloss is quantified in N_{PL} [e.g. 128] intervals ; [max. number of cells is 30]).
- Inter-cell interference measurements of all DL time slots requested by the UTRAN (interference is quantified in N_{ICI} [e.g. 32] intervals, due to asymmetry up to 14 time slots are possible).
- BER of serving link (quantified in N_{BER} [e.g. 16] intervals).

- Transmission power of the UE on serving link (separated in N_{TX} [e.g. 64] intervals).
- DTX flag link.

Further measurements and reports can be requested by the UTRAN.

The RLC informs the DCA about transmission errors. The interaction between DCA and RLC depends on the RLC operation mode.

9 Power Management

9.1 Variable Rate Transmission

9.1.1 Examples of Downlink Power Management

When an RB connection with variable rate transmission is established, the RRC considers the down-link traffic conditions, then assigns the TFCS to MAC and allowable transmission power to L1. The allowable transmission power can be determined according to the service requirements and the traffic conditions, and is updated for each user when the traffic conditions change. RRC also assigns a measurement to Node B that sets the allowable transmission power to the transmitted code power.

During a call, the physical layer averages the transmission power for that UE over one or several frames. If the averaged transmission power for the UE becomes higher than the allowable transmission power, that is, the channel conditions are bad, L1 indicates to MAC that the "Allowable transmission power has been reached". The MAC in response reduces the data rate within TFCS, and the power control procedure then reduces the total transmission power for that UE and excess interference to other UEs is avoided. The PDUs that can not be transmitted in a TTI shall be buffered according to the discard function set by RRC.

When channel conditions improve and the averaged transmission power falls [margin] dB below than the allowable transmission power the physical layer indicates to MAC that the "Average transmission power is below allowable transmission power by margin dB" (the values for [margin] are chosen to match the power requirements of different increments for the transport channels within the TFCS). If there is enough data to be sent the MAC in response increases the data rate by increasing the number of transport blocks delivered to L1 and the physical layer increases the total transmission power to the UE by the predefined amount. This allows data that was buffered during bad channel conditions to be delivered to the UE.

Simulation results on down-link variable rate packet transmission are provided in Appendix E.

9.1.2 Examples of Uplink Power Management

When an RB connection with variable rate transmission is established, the RRC assigns the TFCS and the allowable transmission power to the UE. The maximum allowed UE transmitter power is defined in [9].

During a call, the physical layer averages the transmission power over one or several frames. If the UE output power measured over at least [t1] ms is [margin1] dB within the maximum, the UE shall adapt the transport format combination corresponding to the next lower bit-rate. The PDUs that can not be transmitted in a TTI shall be buffered according to the discard function set by RRC.

When channel conditions improve and the averaged transmission power falls [margin] dB below than the allowable transmission power (the values for [margin] are chosen to match the power requirements of different increments in the number of transport channels within the TFCS) and there is enough data to be sent the UE shall continuously estimate whether the output power needed for a switch to the transport format combination corresponding to the next higher bit-rate does not exceed [margin] dB below the maximum. If the UE has enough power to support that up-switch for at least [t2] ms the UE shall increase the data rate by increasing the number of transport blocks delivered to L1 and the physical layer increases the total transmission power by the predefined amount. This allows data that was buffered during bad channel conditions to be transmitted to Node B.

UE transport format selection shall be done according to [18] considering logical channel priorities. If the bit rate of a logical channel carrying data from a codec supporting variable rate operation is impacted by the transport format combination selection, the codec data rate shall be adopted accordingly.

Minimum requirements for t1, t2 (multiple of 10ms) and margin as well as maximum delay requirements for a transport format combination switch are defined in [16].

9.2 Site Selection Diversity Power Control (SSDT)

Site Selection Diversity Transmit Power Control (SSDT) is a form of power control for the downlink that can be applied while a UE is in soft handover (SHO). This subclause explains how SSDT works, and provides some examples when SSDT should be used. Simulations have been performed comparing SHO with SSDT to normal SHO: results are presented in Annex D.

In SHO, a UE has DL connections to more than one cell. Thus, one UE contributes to the DL interference in several cells. SSDT is a power control method that reduces the DL interference generated while the UE is in SHO. The principle of SSDT is that the best cell of the active set is dynamically chosen as the only transmitting site, and the other cells involved turn down their DPDCHs. The DPCCH is transmitted as normally (see figure below).

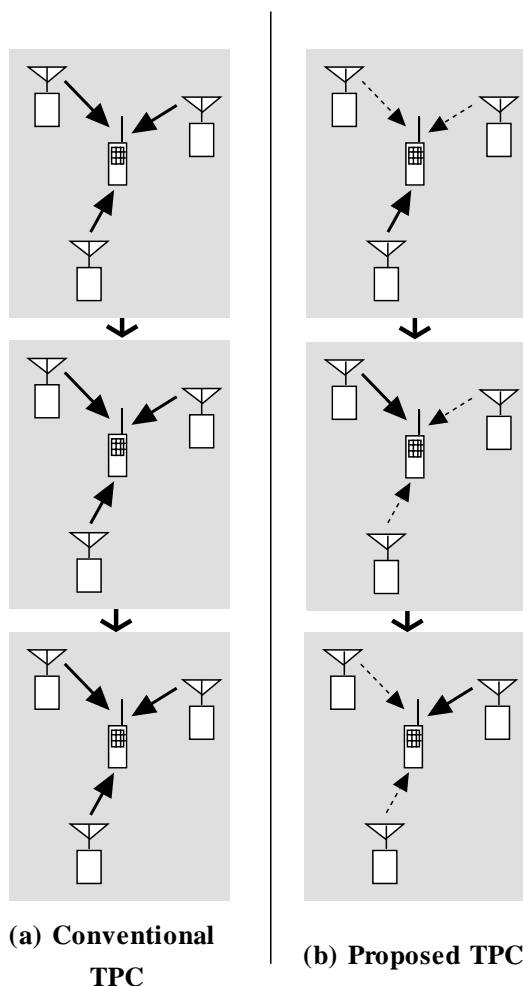

Figure 9-1: Principle of SSDT in comparison to conventional SHO

Each cell is given a temporary identification number. The UE measures the pilot power of the PCCPCHs, and chooses the best one as its 'primary' cell. The temporary id of this primary cell (the 'primary id') is transmitted on the UL DPCCH to all Node Bs of the active set. A cell that has been selected as primary station transmits its dedicated channels with the power necessary to reach the desired SIR target, whereas all other cells switch off their downlink DPDCH transmission. The 'primary id' is updated by the UE at a frequency of 5, 10 or 20ms. The frequency depends on the SSDT mode and is set by the UTRAN.

In order for the UE to continuously perform measurements and to maintain synchronisation, the 'secondary' cells continue to transmit pilot information on the DPCCH.

The prerequisite for using SSST during an RRC connection or during a part of an RRC connection is that all Node B involved support SSST. SSST is controlled by L3 procedures. The control involves assignment of temporary ids, setting an SSST mode and switching SSST on or off. The control information itself (temporary ids) terminates in the L1 of Node B and UE respectively.

9.3 Examples of balancing Downlink power

9.3.1 Adjustment loop

Adjustment loop is a method for balancing downlink power among active set cells during soft handover. For adjustment loop, DL reference power P_{REF} and DL power convergence coefficient r ($0 < r < 1$) are set in the active set cells during soft handover so that the two parameters are common to the cells. For simplicity, DL powers of two cells are considered in this explanation. Adjustment loop works in addition to inner loop power control, and DL power at slot i of two cells, $P_1(i)$, and $P_2(i)$, are updated at a certain interval (typically in every slot as in this explanation) as follows:

$$P_1(i+1) = P_1(i) + (1 - r)(P_{REF} - P_1(i)) + S_{INNERLOOP1}(i)$$

$$P_2(i+1) = P_2(i) + (1 - r)(P_{REF} - P_2(i)) + S_{INNERLOOP2}(i)$$

where $S_{INNERLOOP1}(i)$ is the result of the inner loop power control.

The difference is derived from the two equations above if TPC error does not occur i.e. $S_{INNERLOOP1}(i)$ and $S_{INNERLOOP2}(i)$ are equal:

$$P_1(i+1) - P_2(i+1) = r(P_1(i) - P_2(i)) = r^i(P_1(1) - P_2(1))$$

Therefore the difference converges at zero when r is smaller than one. Simulation results are available in Appendix F.

10 Radio Link Surveillance

10.1 Mode Control strategies for TX diversity

10.1.1 TX diversity modes

TX diversity modes can be classified into two categories:

- Open loop modes
- Closed loop modes

In open loop mode no feedback information from the UE to the node B is transmitted in order to control how the signal is transmitted from the diversity antennas. This is in contrast to closed loop operation where UE sends feedback information to the Node B in order to optimise the transmission from the diversity antennas.

For a detailed description of TX diversity techniques in both FDD and TDD mode, refer to [L1 Spec].

10.1.2 Mode Control Strategies

10.1.2.1 DPCH

What mode will be used on DPDCH and when is controlled by UTRAN. Important criteria for the mode control are the radio channel conditions. This is because depending on the radio channel different modes will provide the best performance.

Regarding the downlink performance there are two important factors that should be considered when doing mode control:

- Maximum Doppler frequency (i.e., speed of the UE).
- Number of multipath components.

Basically the UE could measure both of these and report back to UTRAN. As it happens both of these could be measured by UTRAN as well. Therefore, there is no need to signal this information from UE.

The use of TX diversity on dedicated channels is signalled to the UE in call set-up phase.

10.1.2.2 Common channels

Only open loop can be used for PCCPCH, SCCPCH, and AICH. For common channels the UE gets information about the use of TX diversity through system information broadcast on BCCH. Each of the different common channels above can utilise TX diversity irrespective of it is used on any of the other common channels.

11 Codec mode control

11.1 AMR mode control

The AMR speech codec consists of the multi-rate speech codec with eight source rates from 4.75 kbit/s to 12.2 kbit/s [12]. The change between the AMR specified rates could occur in the WCDMA in downlink, when traffic on the air interface exceeds the acceptable load, or when the connection based FER value indicates the bad quality of the connection. In uplink the corresponding change can be made when there is need to extend the uplink coverage area for speech by using several AMR modes or when the measured load on the air interface is reported to exceed the acceptable level.

In principle the speech coder is capable of switching its bit rate every 20 ms speech frame upon command. [12] However in practice the AMR mode adaptation is needed less frequently.

In WCDMA the network architecture has been defined to consist of two different network domains; UTRAN and Core Network (CN). Due to this definition and decisions about the location of the Transcoder, the AMR related functions are forced to divide between the previously mentioned network domains.

The location of the Transcoder in WCDMA was defined to be in the core network domain, and logically outside the Access Stratum. Thus also the location of the AMR speech codec is into the Core Network as well.

From the data transfer point of view the defined location of the encoder in the NW side means that at least all AMR coded data is going to be transmitted not only via Iub and air interface but also via Iu –interface (see Figure 11-1).

The functionality of the codec mode control on the contrary can not locate in the Transcoder, because this control entity needs information from the air interface to make decision about the valid AMR modes for the AMR related connections. Thus the only domain, which can provide this kind of information from the air interface to AMR codec mode control entity, is UTRAN. In GSM the control of the codec mode is provided by the BTS, but in WCDMA this solution is not applicable due to soft handover procedure defined for the dedicated traffic channels. Thus the AMR mode control function should be a part of the RNC functionality. In RNC the most natural place to perform the control of the AMR mode is RRM, because RRM is already responsible for reserving and controlling resources from the air interface. Thus all information, which is needed for the AMR adaptation, can be found from the RRM, which is a part of the current L3 functionality (see Figure 11-1).

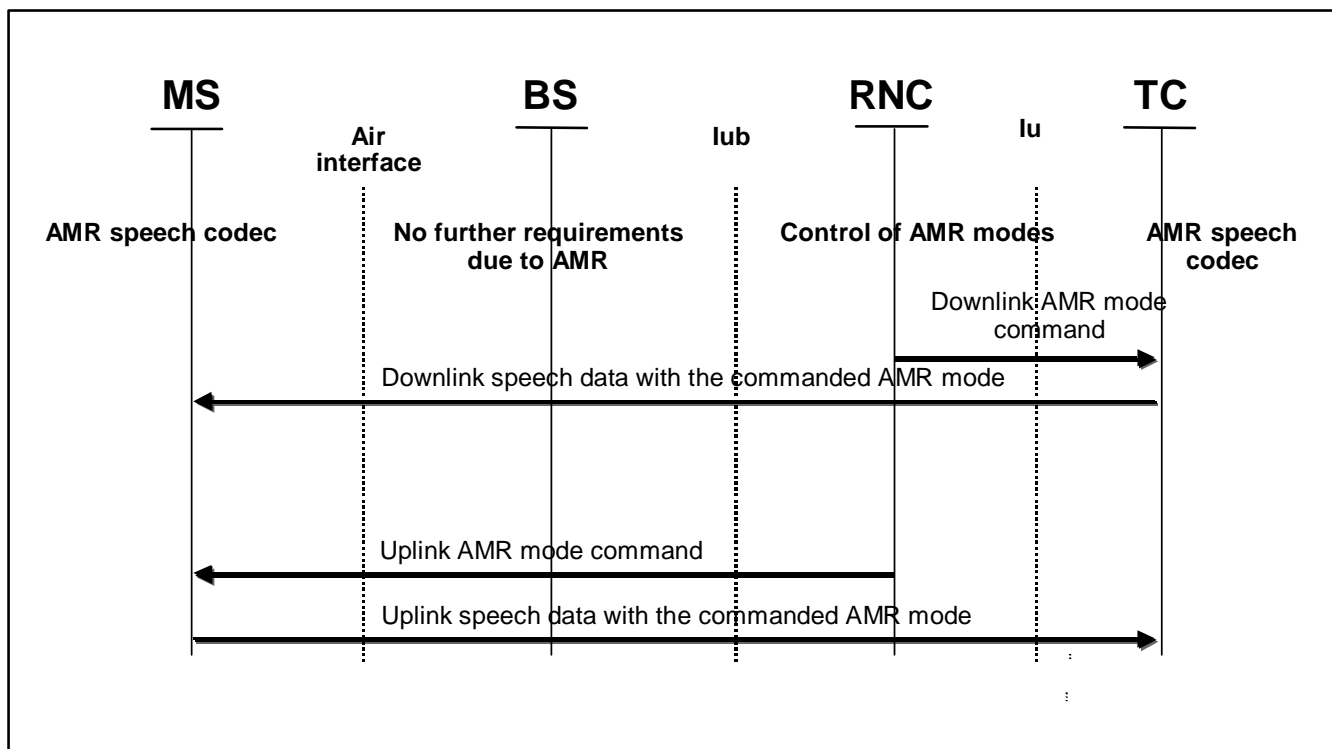

Figure 11-1

In the WCDMA the AMR mode adaptation is carried out with the aid of AMR mode control function, which is responsible for detecting the need of the AMR mode adaptation and to initiate required procedures to change the current AMR mode to the newly selected AMR mode. The AMR mode change request can be made with the aid of the AMR mode command, which is sent from the RNC either to the Transcoder for downlink data transfer or to the UE for uplink data transfer. In principle the supported AMR mode adaptation can be asymmetric, which implies the possibility to use different AMR modes in uplink and downlink during active speech call.

Therefore, the role of the RRM during the AMR coded speech call will be basically the role of the supervisor of the connection.

The AMR mode command is used to change the current AMR mode to the new one, which suits better to the conditions on the air interface. The command is sent from the UTRAN to the appropriate AMR codec, which locates either in the transcoder or in the UE. In which encoder the command is sent depends on direction of the data transmission. If the AMR mode - in question - is intended to be used in downlink the command is sent to the encoder inside the transcoder via Iu -interface, whereas AMR code needed on uplink is sent to the UE through air interface.

The initialisation of AMR mode command will base on load information, which has been received from the air interface. The following table shows the required information during the AMR mode adaptation in WCDMA:

Information used in AMR control	Load
Downlink information	BS reports total BS transmission power
Uplink information	BS measurers total interference level

When RRM indicates the need for the AMR mode adaptation, RRC may generate the requested AMR mode command and send it to the encoder, or RRC may request MAC -d to perform the same functions. Which layer is used depend on whether the AMR mode command is intended to use on uplink or on downlink, and whether inband or outband signalling is used for transferring the command from the UTRAN to the encoder.

For the downlink, the AMR mode command from RNC to TC is realised as inband.

Transport format for the transport channel carrying the different classes of AMR source codec provides an unambiguous mapping of the codec mode that is used.

Annex A: Simulations on Fast Dynamic Channel Allocation

A.1 Simulation environment

The presented simulations are performed in the following environments and services according to the requirements in the following documents:

- ETSI TR 101 112, Selection procedures for the choice of radio transmission technologies of the Universal Mobile Telecommunications System UMTS (UMTS 30.03), version 3.2.0, April 1998.
- Seppo Hämäläinen, Peter Slanina, Magnus Hartman, Antti Lappeteläinen, Harri Holma, Oscar Salonaho, A Novel Interface Between Link and System Level Simulations, Acts Mobile Communications Summit '97, pp. 599-604, Aalborg/Denmark, Oct 7-10, 1997.

Absolute capacities [kbit/s/MHz/cell] were published in:

- ETSI Tdoc SMG2 306/98, UTRA TDD Link Level and System Level Simulation Results for ITU Submission, Source: Siemens, Helsinki, Sep 8-11, 1998.
1. Macro (Vehicular) environment for the UDD 144 kbit/s service.
 2. Micro (Outdoor-to-Indoor Pedestrian) environment for the UDD 384 kbit/s service.

A.2 Results

The relative load of the cell is used for the abscissa (horizontal axis) in all of the plots. Here, a relative load of 100% refers to the maximum cell load obtainable with code-pooling under the ETSI unsatisfied user criterion (in accordance with ETSI TR 101 112). Vertically, the percentage of unsatisfied users is shown.

A.2.1 Macro UDD 144

In the Macro environment the UDD 144 service is simulated with Hybrid ARQ Type II-III using an adaptive code-rate between 1 and $\frac{1}{2}$.

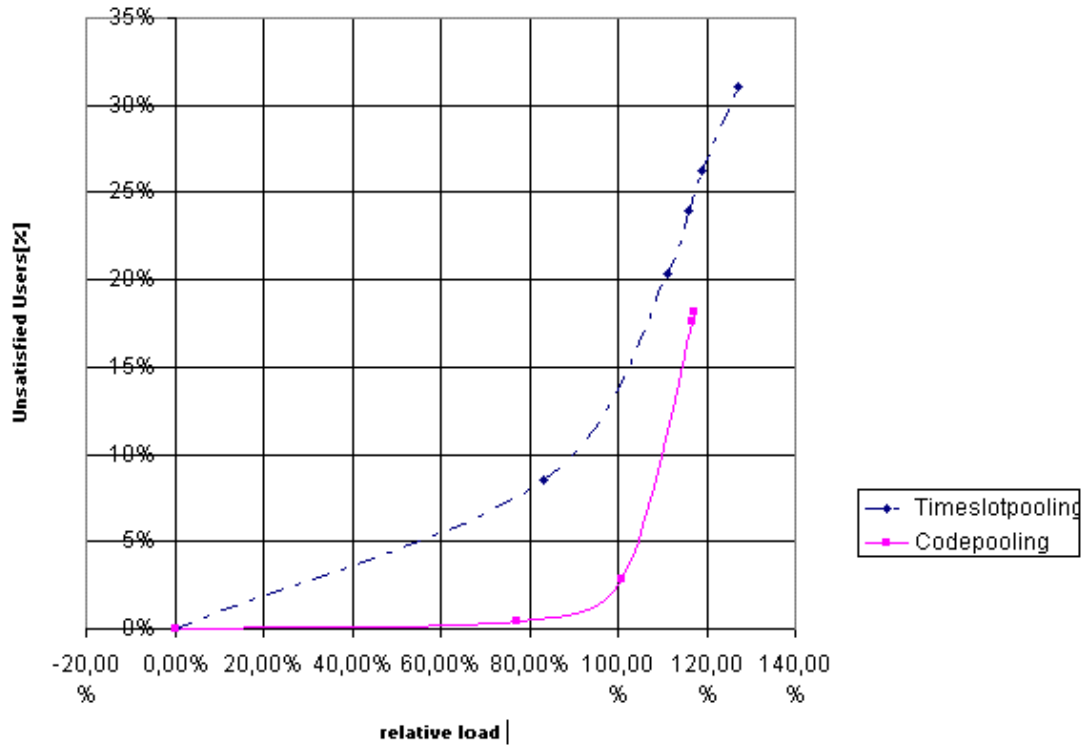

Figure A-1

A.2.2 Micro UDD 384

In the Micro environment the UDD 384 service is simulated with Hybrid ARQ I using code-rates 1 and 2/3.

A.2.2.1 Code rate 1

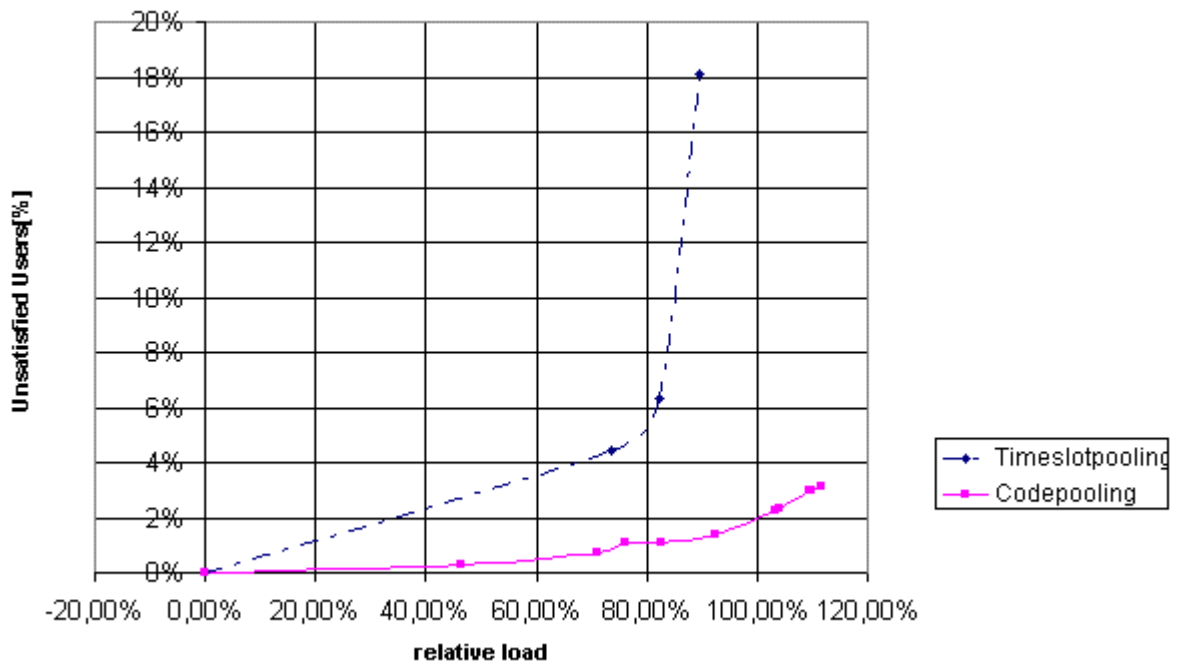

Figure A-2

A.2.2.2 Code rate 2/3

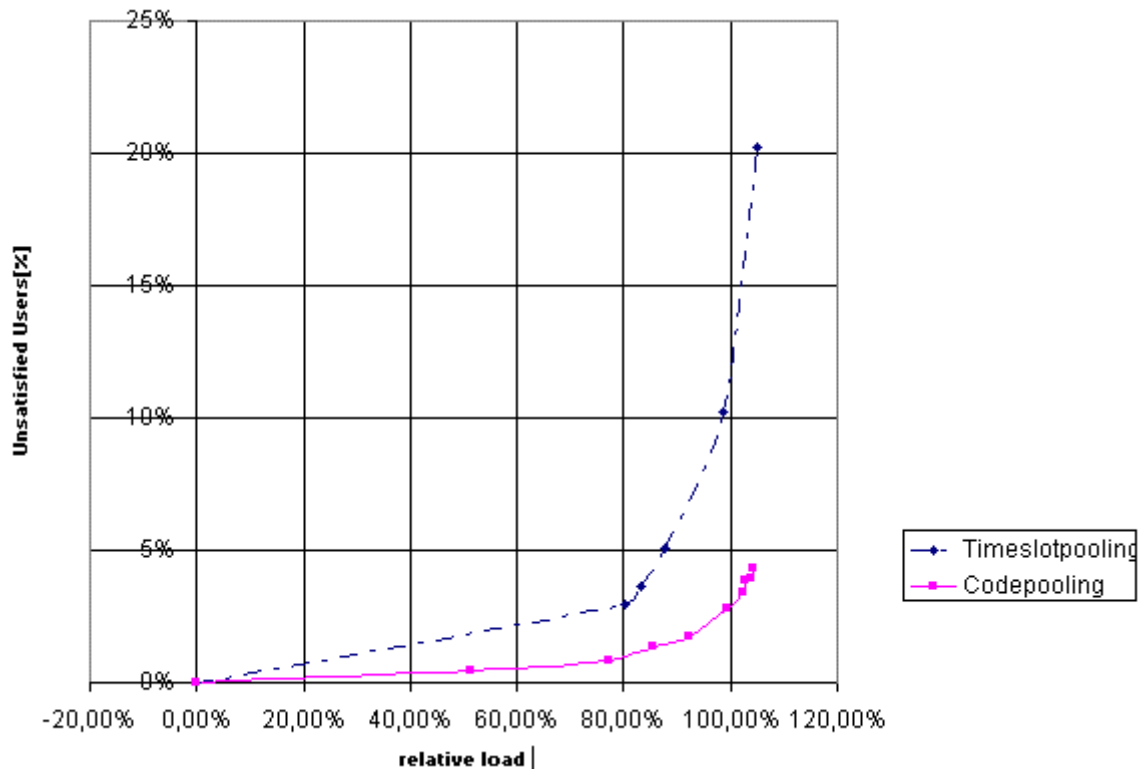

Figure A-3

A.3 Conclusions

With both Hybrid ARQ I and Hybrid ARQ II code pooling performs better than time slot pooling. This is explained as follows: Code-pooling performs better in conjunction with the initial transmission of Hybrid ARQ Type II-III. Timeslot pooling suffers from a high probability of low CIR in at least one of the used timeslots of the PDU. This leads to a high initial transmission failure probability because the initial transmission is sent almost uncoded. When code-pooling is applied, the whole PDU depends on the same interference level on all codes: the probabilities of low CIR on each spreading-code within the same timeslot are strongly coupled.

- The probability of PDU transmission failure for code-pooling is approximately the same as the probability of low CIR in a single timeslot.
- The probability of PDU transmission failure for timeslot-pooling is approximately the same as the probability of low CIR in at least one of the used timeslots.

This advantage of code-pooling results in lower numbers of unsatisfied users. These results clearly recommend that the DCA prefers code pooling over timeslot pooling for UDD packet data in TDD mode.

Annex B: Radio Bearer Control – Overview of Procedures: message exchange and parameters used

B.1 Examples of Radio Bearer Setup

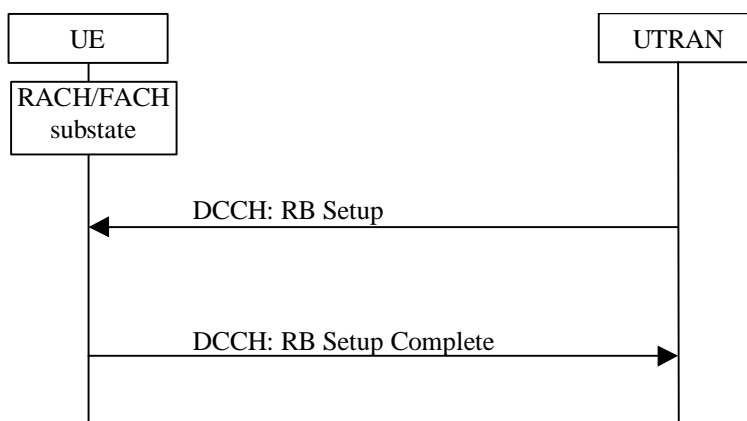

Figure B-1: Radio Bearer setup on common transport channel

B.1.1 RRC Parameters in RB Setup

This message includes **RB identity** for the new RB and **RLC info**. It also includes **two different multiplexing configurations** giving the transport channel this RB could be mapped onto. One configuration to be used on a common transport channel and one for a dedicated transport channel.

For the common transport channel this message includes a new **Transport format set for FACH**, and a **Transport format set for RACH**.

For the dedicated transport channel (pre-configured, not yet used) this message includes the **transport formats for DCH1 and DCH2**, and also the **transport format combinations** used in e.g. B.2.1, after the switch.

B.1.2 RRC Parameters in RB Setup Complete

This message only includes the message type.

B.2 Examples of Physical Channel Reconfiguration

This RRC procedure is used to reconfigure the Physical channel and can by that also trigger Transport channel type switching.

Below several examples of Physical Channel reconfigurations are shown, triggered by different amount of UL or DL data.

B.2.1 Increased UL data, with switch from RACH/FACH to DCH/DCH

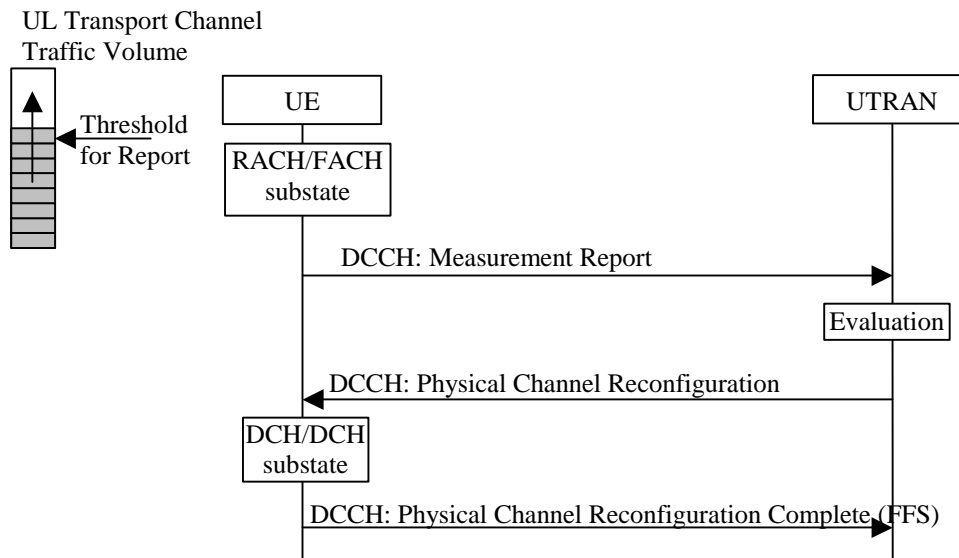

Figure B-2: Physical channel reconfiguration triggered by increased UL data and with a switch from RACH/FACH to DCH/DCH

B.2.1.1 RRC Parameters in Measurement Report

This message includes a **Measurement Identity number** so that UTRAN can associate this report with a Measurement control message. It also includes the **Measurement result** stating RB Identity and optionally Reporting Quantities (i.e. RLC Buffer Payload, Average of RLC Buffer Payload, and Variance of RLC Buffer Payload for each RB).

B.2.1.2 RRC Parameters in Physical Channel Reconfiguration

This message includes **DL channelisation codes** and **DL scrambling code** for the DPCH. It also includes **UL channelisation codes** and **scrambling code** for the DPCH.

B.2.1.3 RRC Parameters in Physical Channel Reconfiguration Complete

This message only includes the message type.

B.2.2 Increased DL data, no Transport channel type switching

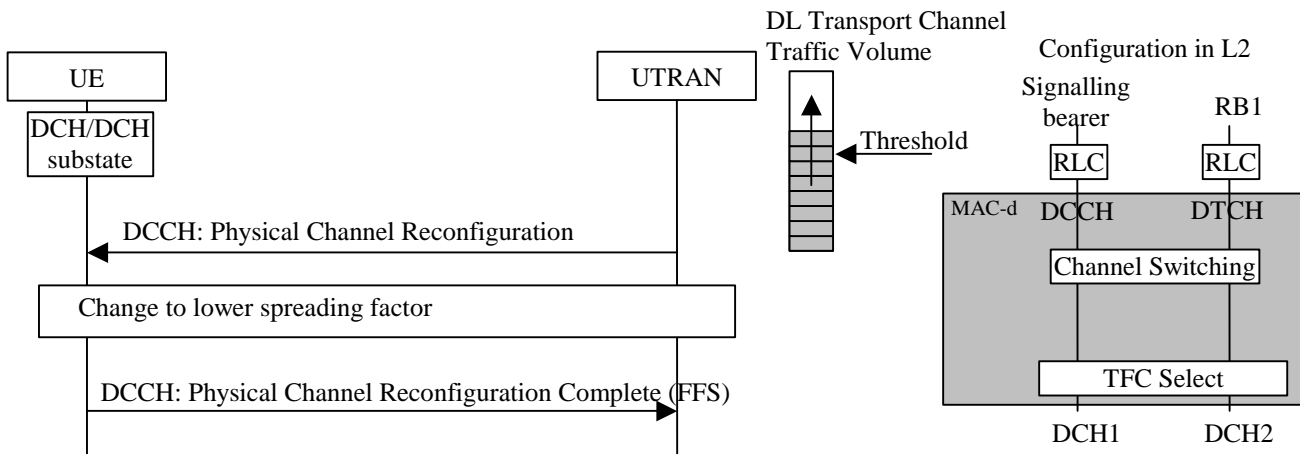

Figure B-3: Physical channel reconfiguration triggered by increased DL data and configuration in UTRAN DL

B.2.2.1 RRC Parameters in Physical Channel Reconfiguration

This message includes **new DL channelisation codes** for the DPCH with lower spreading factor for all cells that the UE is connected to.

B.2.2.2 RRC Parameters in Physical Channel Reconfiguration Complete

No identified parameters

B.2.3 Decrease DL data, no Transport channel type switching

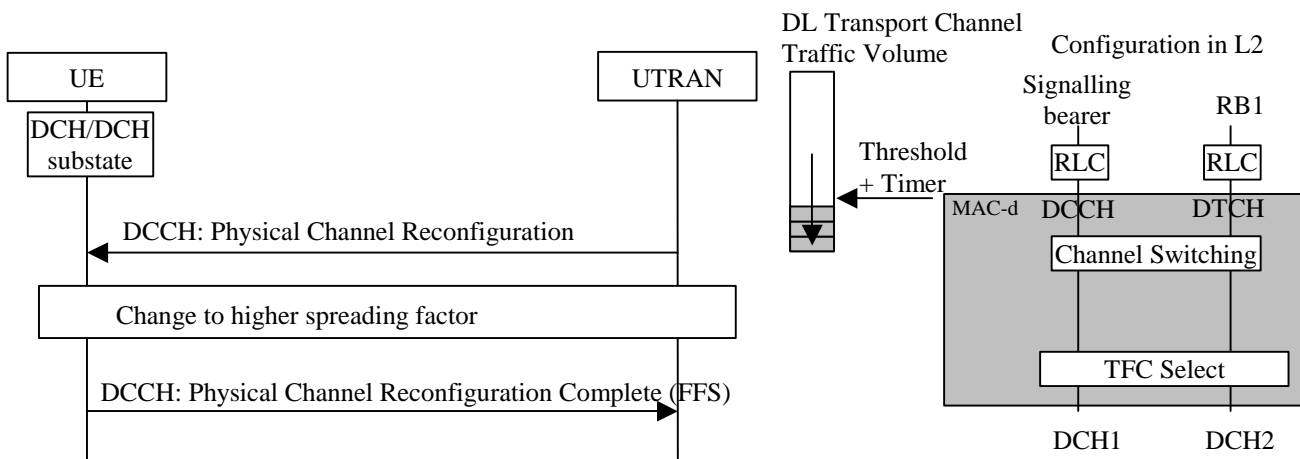

Figure B-4: Physical channel reconfiguration triggered by decreased DL data and configuration in UTRAN DL

B.2.3.1 RRC Parameters in Physical Channel Reconfiguration

This message includes new **DL channelisation codes** for DPCH with higher spreading factor for all cells that the UE is connected to.

B.2.3.2 RRC Parameters in Physical Channel Reconfiguration Complete

This message only includes the message type.

B.2.4 Decreased UL data, with switch from DCH/DCH to RACH/FACH

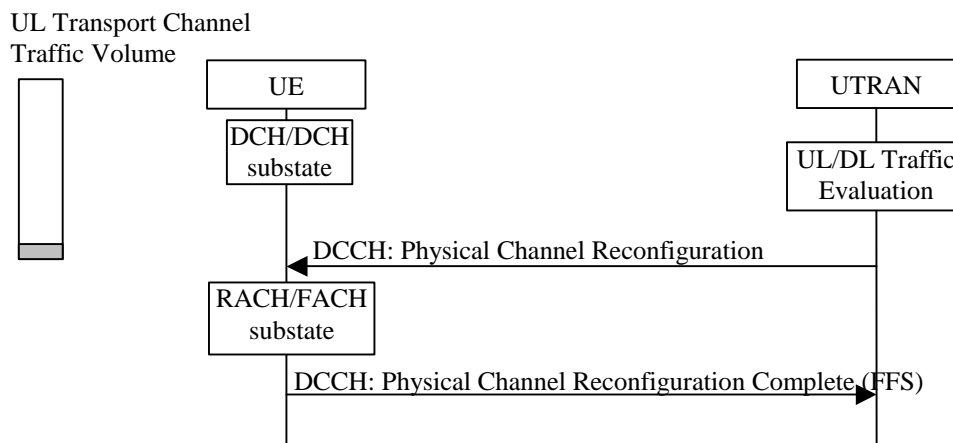

Figure B-5: Physical channel reconfiguration triggered by decreased UL data and with a switch from DCH/DCH to RACH/FACH

B.2.4.1 RRC Parameters in Physical Channel Reconfiguration

This message includes a **PRACH spreading factor** for the UL i.e. stating the minimum spreading factor to be used, and the **preamble signatures** that are allowed. Further, for the PRACH, which **access slots** are allowed and the **preamble spreading code** is included.

For the DL the message includes **scrambling code**, i.e. indicating to which cells FACH the UE should be connected to, and a **channelisation code** for the secondary CCPCH.

NOTE: The common channel parameters are the same that is transmitted on the BCCH. The reason to send it in this message is to remove the necessity for the UE to read BCCH at this switch.

B.2.4.2 RRC Parameters in Physical Channel Reconfiguration Complete

This message only includes the message type.

B.3 Examples of Transport Channel Reconfiguration

B.3.1 Increased UL data, with no transport channel type switching

In the example below, the UE is allowed to send more data in the UL when on dedicated transport channel, although the common transport channel configuration is still the same. To make use of the new transport format combinations the physical channel must also be reconfigured to allow a lower spreading factor.

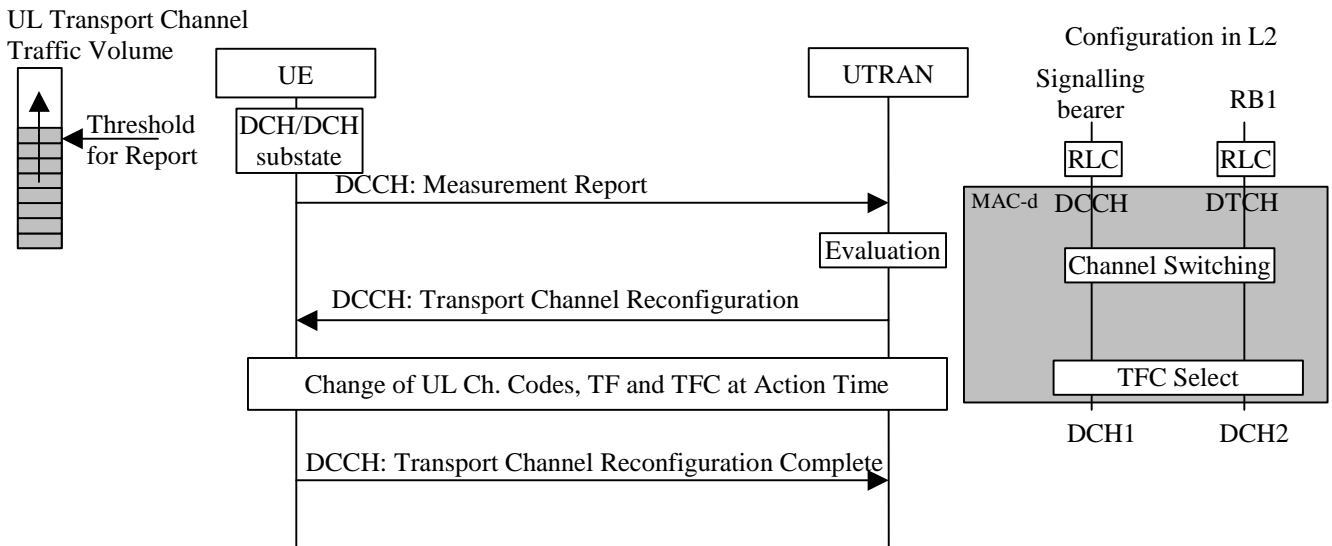

Figure B-6: Transport channel reconfiguration triggered by increased UL data and configuration in UTRAN DL

B.3.1.1 RRC Parameters in Measurement Report

This message includes a **Measurement Identity number** so that UTRAN can associate this report with a Measurement control message. It also includes the **Measurement result** stating RB Identity and optionally Reporting Quantities (i.e. RLC Buffer Payload, Average of RLC Buffer Payload, and Variance of RLC Buffer Payload for each RB).

B.3.1.2 RRC Parameters in Transport Channel Reconfiguration

This message includes a new **Transport format set** for DCH2 and a new **Transport format combination set**. An **Activation time** must also be included if the different TFCIs can not coexist during the reconfiguration.

It also includes **UL channelisation codes** for the DPCH.

B.3.1.3 RRC Parameters in Transport Channel Reconfiguration Complete

This message only includes the message type.

B.3.2 Decreased DL data, with switch from DCH/DCH to RACH/FACH

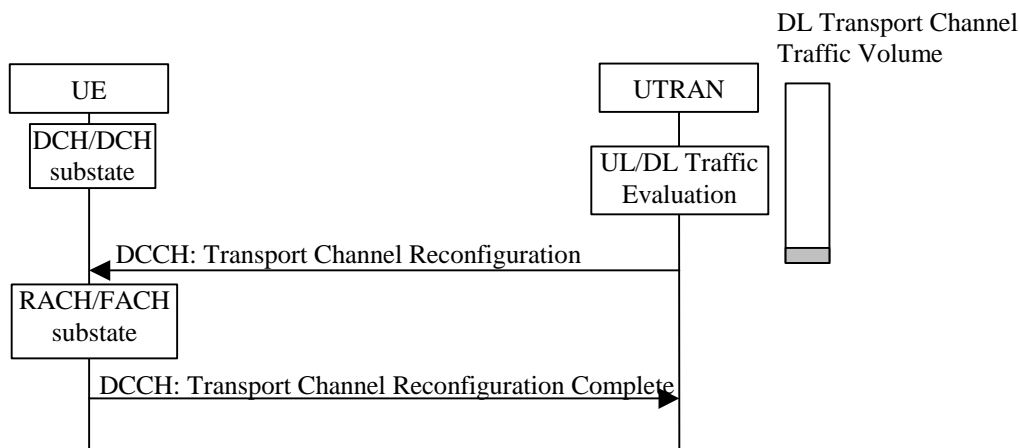

Figure B-7: Transport channel reconfiguration triggered by decreased DL data and with a switch from DCH/DCH to RACH/FACH

B.3.2.1 RRC Parameters in Transport Channel Reconfiguration

This message includes new **Transport format set for RACH**, a **PRACH spreading factor** i.e. stating the minimum spreading factor to be used, and the **preamble signatures** that are allowed. Further, for the PRACH, which **access slots** are allowed and the **preamble spreading code** is included.

For the DL the message includes a new **Transport format set for FACH**, the **scrambling code**, i.e. indicating to which cells FACH the UE should be connected to, and a **channelisation code** for the secondary CCPCH.

NOTE: The common channel parameters are the same that is transmitted at the BCCH. The reason to send it in this message is to remove the necessity for the UE to read BCCH at this switch.

B.3.2.2 RRC Parameters in Transport Channel Reconfiguration Complete

This message only includes the message type.

B.4 Examples of RB Reconfiguration

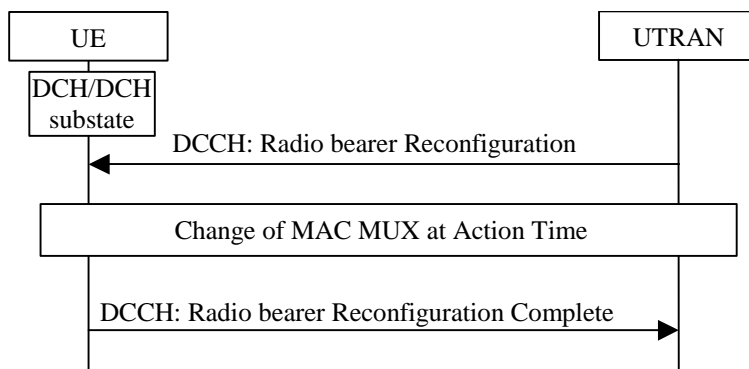

Figure B-8: RB Reconfiguration

B.4.1 RRC Parameters in Radio Bearer Reconfiguration

This message includes a multiplexing option with Transport channel identity DCH2 for both RB1 and RB2, stating that both these RBs should use the same transport channel. For each of these two RBs a **Logical channel identity value** and a **priority** must be given to define the MAC MUX.

Also included is a new **Transport format set** for DCH2 and a new **Transport format combination set** (both for UL and DL if the multiplexing is changed both in UL and DL).

It is also possible to reconfigure the physical channel and include new **channelisation codes** for the DPCH with different spreading factor for all cells that the UE is connected to.

B.4.2 RRC Parameters in Radio Bearer Reconfiguration Complete

This message only includes the message type.

Annex C: Flow-chart of a Soft Handover algorithm

In this Appendix a flow-chart of the Soft Handover algorithm described in subclause 6.1.4.1 is presented.

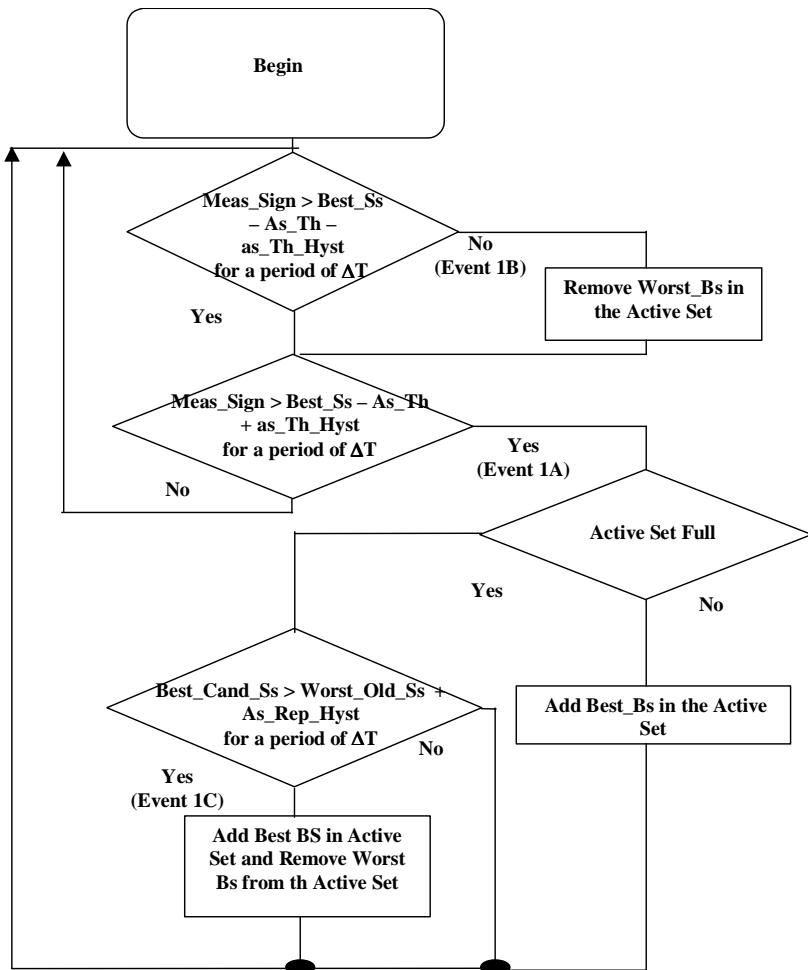

Figure C-1: flow-chart of a Soft Handover algorithm

Annex D: SSDT performance

Site Selection Diversity Transmit Power (SSDT) is described in subclause 10.2.

Computer simulations were carried out to investigate the behaviour of SSDT under ETSI&ITU-R guidelines for IMT-2000 RTT evaluation. The results are compared to a conventional power control method, where the transmit power of all BS involved is controlled so that the correct target SIR value is reached.

The figure below shows capacity versus Doppler frequency for SSDT and conventional TPC (normal SHO). The simulations show that SSDT is superior to normal SHO at low speed, and that increases capacity by reducing overall interference. The capacity gains are approximately 40% without UE's diversity and 50% with UE's diversity at walking speed. At high mobile speed, the advantage of SSDT gradually diminishes. The performance degradation of SSDT at higher speed is caused by the limited update frequency of the primary cell id.

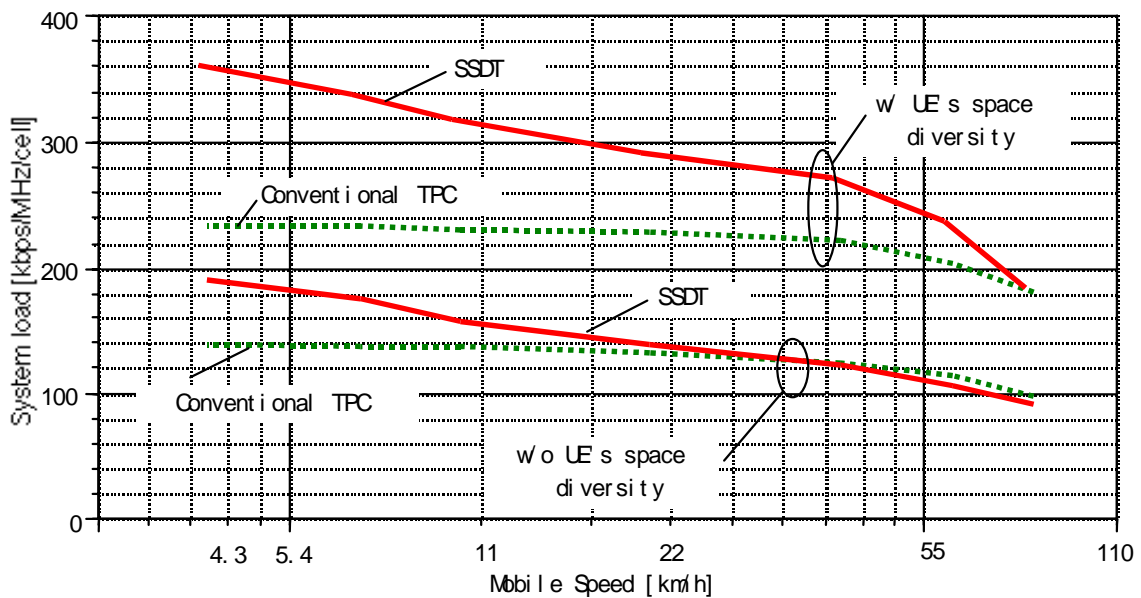

Figure D-1: Capacity versus Doppler frequency for SSDT and conventional TPC (normal SHO)

Annex E: Simulation results on DL Variable Rate Packet Transmission

E.1 Simulation assumption

The simulation model is based on the ARIB's model used for RTT proposal. Following are detailed assumptions:

- down-link, vehicular environment system-level simulation (ITU model);
- perfect SIR estimation (no delay on SIR estimation);
- UDD144k users and SPEECH users are considered;
- voice activation of 50 % for SPEECH service;
- traffic call model is not introduced for UDD service (continuous transmission).

Other simulation parameters are shown in Tables 17.1 and 17.2.

Table E-1: Environment models

Cell radius	1000 m
Site to site separation	3000 m
Cell layout	wrap around
Data sample cell	all cells
# of sectors	3
UE speed	120 km/h

Table E-2: Power setting and other parameters

	SPEECH 8kbps	UDD 144kbps
Diversity	No	No
Processing gain	512 (27.1dB)	67.4 (18.3dB)
TCH max. TX power	30 dBm	30 dBm
TCH min. TX power	10 dBm	10 dBm
BCH TX power	30 dBm	30 dBm
HO algorithm settings		
DHO windows	3 dB	N/A
Active set update rate	0.5 second	0.5 second
Active set max. size	2	1
Required Eb/No	8.8 dB	2.9 dB
TCH allowable TX power (TXPOW_ALLOWABLE)	-	30, 27, 24 dBm
Number of users	60, 62, 64, 68, 70	5

E.2 Simulation results

Tables 17.3, 17.4 and 17.5 are simulation results for TXPOW_ALLOWABLE of 30, 27 and 24 dBm, respectively. In these tables, 'satisfied user' means the user having sufficiently good quality, i.e., the required Eb/No is satisfied, more than 95% of the session time. The results show that:

- Compared with "Fixed Rate", "Variable Rate" can achieve the same or higher data rate as well as better quality for both services.
- "Variable Rate" can accommodate more users by allocating a lower power threshold for high-rate packet users.

- "Variable Rate" can control the average transmission power not only for UDD144k users but also for SPEECH users. This means that "Variable Rate" can keep the system stable by allocating an appropriate power threshold (TXPOW_ALLOWABLE).

Because of these advantages, the system may tolerate high-power emergent users.

Table E-3: Simulation results for TXPOW_ALLOWABLE = 30 dBm

Number of users (SPEECH + UDD144k)	Fixed Rate				Variable Rate				
	SPEECH		UDD144k		SPEECH		UDD144k		
	satisfied user	Average TXPOW [dBm]	Satisfied user	average TXPOW [dBm]	satisfied user	average TXPOW [dBm]	satisfied user	average TXPOW [dBm]	average data rate [times]
60 + 5	100 %	21.9	93.6 %	25.8	97.58 %	23.8	90.82 %	28.6	1.59
62 + 5	100 %	22.8	41.6 %	26.6	99.59 %	28.6	97.26 %	28.6	1.44
64 + 5	-	-	-	-	99.97 %	28.6	99.54 %	28.6	1.31
66 + 5	-	-	-	-	100 %	28.6	100 %	28.6	1.18
68 + 5	-	-	-	-	100 %	28.6	99.98 %	28.6	1.04
70 + 5	-	-	-	-	99.94 %	28.6	100 %	28.6	0.91

Table E-4: Simulation results for TXPOW_ALLOWABLE = 27 dBm

Number of users (SPEECH + UDD144k)	Fixed Rate				Variable Rate				
	SPEECH		UDD144k		SPEECH		UDD144k		
	satisfied user	Average TXPOW [dBm]	satisfied user	average TXPOW [dBm]	satisfied user	average TXPOW [dBm]	satisfied user	average TXPOW [dBm]	average data rate [times]
60 + 5	100 %	21.9	93.6 %	25.8	99.98 %	25.6	99.92 %	25.6	1.29
62 + 5	100 %	22.8	41.6 %	26.6	100 %	25.6	100 %	25.6	1.19
64 + 5	-	-	-	-	100 %	25.6	100 %	25.6	1.08
66 + 5	-	-	-	-	100 %	25.6	100 %	25.6	0.97
68 + 5	-	-	-	-	100 %	25.6	100 %	25.6	0.85

Table E-5: Simulation results for TXPOW_ALLOWABLE = 24 dBm

Number of users (SPEECH + UDD144k)	Fixed Rate				Variable Rate				
	SPEECH		UDD144k		SPEECH		UDD144k		
	satisfied user	Average TXPOW [dBm]	satisfied user	average TXPOW [dBm]	satisfied user	average TXPOW [dBm]	satisfied user	average TXPOW [dBm]	average data rate [times]
60 + 5	100 %	21.9	93.6 %	25.8	100 %	22.6	100 %	22.6	0.97
62 + 5	100 %	22.8	41.6 %	26.6	100 %	22.6	100 %	22.6	0.88
64 + 5	-	-	-	-	100 %	22.6	100 %	22.6	0.79

Annex F: Simulation results on Adjustment loop

F.1 Simulation conditions

The performance of adjustment loop is evaluated by means of computer simulation. The assumptions of the simulation are as follows:

- Active set is determined when a call is originated. During the call, sector average of path loss does not change, and the active set is not updated.
- Maximum active set size is three. Relative threshold for soft handover is 6 dB.
- Initial DL power is set to a value common to all active set cells.
- During a call, DL power is not synchronised by messages from RNC.
- Average holding time is 10 sec.
- Path loss of 3.5th power law, log-normal shadowing, and equal level 4 path Rayleigh fading are considered.
- Both uplink and downlink power is updated by inner loop power control in every slot.
- Delay of inner loop power control is one slot.
- Outer loop power control is employed, in which target FER is 0.01.
- Step size of inner loop power is 1 dB.
- When the SIR of TPC command is smaller than a threshold, the degraded TPC command is not used for inner loop power control.
- Reception error of TPC commands is generated in accordance with received SIR.
- Power control range is 20 dB.
- DL reference power P_{REF} is the centre value of power control range.
- DL power convergence coefficient r is 0.96.

F.2 Simulation results

Figure F-1 shows average of DL power difference among cells during soft handover, Figure F-2 shows FER, and Figure F-3 shows average DL power of all calls. During soft handover, DL power is the sum of DL powers of the active set cells. In these figures, performance with adjustment loop (ON) is compared with the performance without adjustment loop (OFF). The performance depends on the DL reference power, i.e. the centre value of the power control range. In this result, ratios of active set size of two and three were both 0.22, and both degraded TPC command rate and TPC error rate were approximately 2 percent.

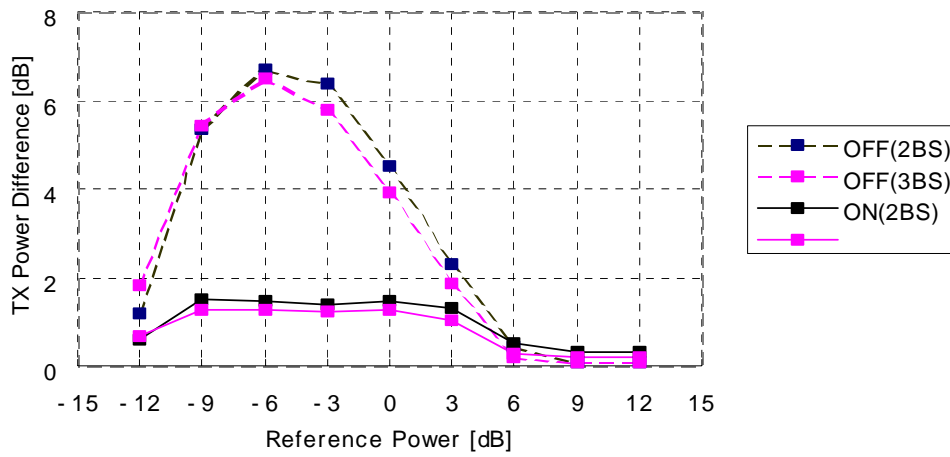

Figure F-1: DL power difference

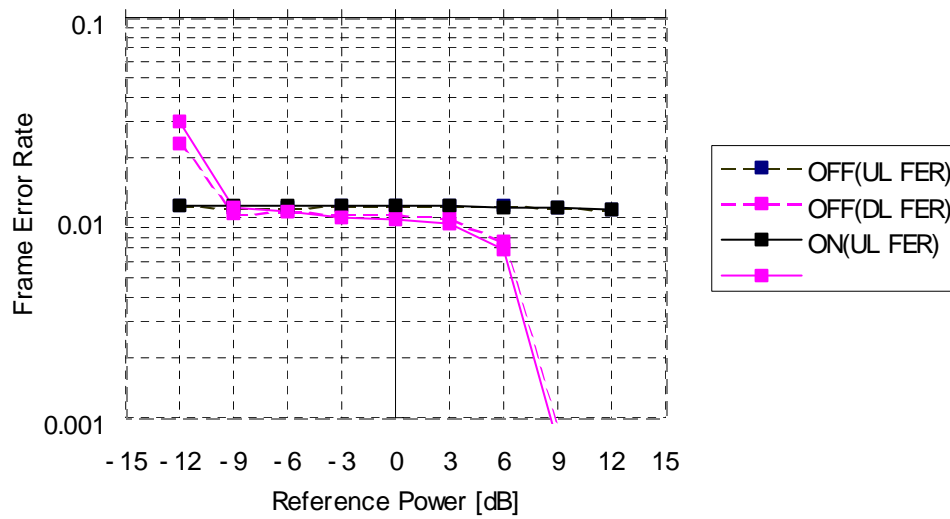

Figure F-2: Frame Error Rate

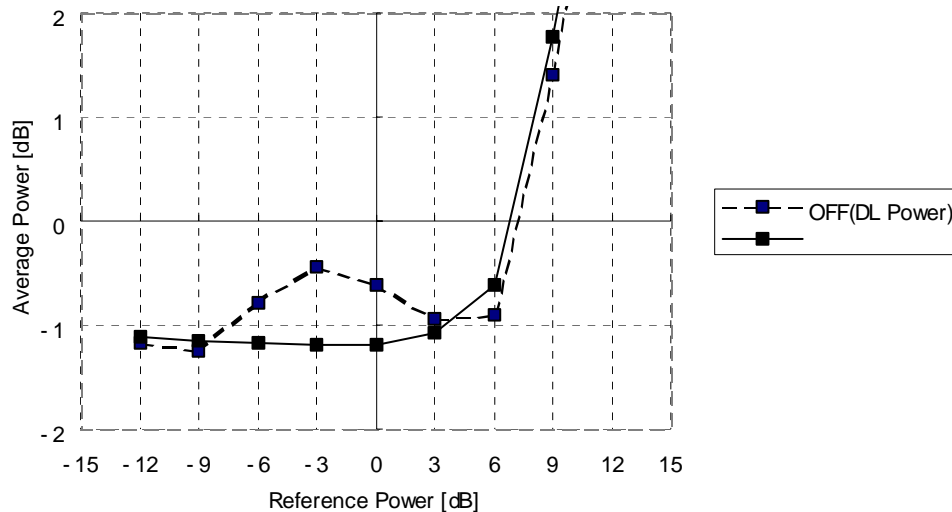

Figure F-3: Average DL power

F.3 Interpretation of results

When the reference power is between -9 dB and 6 dB, FER is maintained at a target value and average DL power stays relatively low. However, when the reference power is less than -9 dB, FER becomes large due to small maximum DL power. On the other hand, when the reference power is more than 6 dB, average DL power is increased due to large minimum DL power.

When adjustment loop is not employed, average DL power depends on the centre value of power control range. With adjustment loop, average DL power is not sensitive to the centre value of power control range. This means that it is possible to keep DL power low quite easily.

With adjustment loop, it is possible to eliminate power drifting problem without the need of frequent signalling of DL Reference Power, and without negative impact on DL inner loop power control.

During soft handover, DL Reference Power is reported from RNC to Node-Bs in NBAP messages. If synchronised Radio Link Reconfiguration is not used, power drifting cannot be eliminated since it is not possible to set the DL Reference Power at all Node-Bs at the same time. If synchronised Radio Link Reconfiguration is used, there is a high probability that the difference of the DL Reference Power and the current DL power is large due to large delays. In such cases, if DL power is set equal to DL Reference Power in a slot in each Node-B, the DL power may become too low or too high. Therefore this may have significant negative impact on DL inner loop power control. It should be also noted that frequent signalling of DL Reference Power will have significant increase of control traffic from RNC to Node-B.

With adjustment loop, DL power adjustment is much smaller than a step of inner loop power control even when the difference of the DL Reference Power and the current DL power is large. This means that it is possible to achieve the high performance of DL inner loop power control.

Annex G:

Simulation results for CPCH

This appendix presents the results of CPCH simulations performed with the OPNET Modeller tool for various traffic loading and cell capacity scenarios. Simulation assumptions and results are presented. The last subclause of the appendix presents RRM strategies based on the simulation results.

G.1 Simulation Assumptions

- Results of Link Level Simulations with ITU channel model is used.
- The preamble detection probability as a function of SNR.
- Window-based and timer-based ARQ is used. So it was captured end-to-end delays.
- 50-200 mobiles are randomly distributed in the coverage area of one cell.
- The access Preamble ramp-up and the collision resolution steps are simulated.
- Each packet is processed serially and independently of others, i.e. aggregation of packets in the UE is not simulated.
- The following tuneable parameters exist in the simulations:
 - N_Max_Frames: maximum length in frames of individual packet.
 - Number of ramp-ups max: number of AP power ramp up cycles without APCH response before access is aborted and packet transmission fails.
 - Traffic model: includes packet inter-arrival time, session inter-arrival time, # of packets per packet call, number of packet calls per session, Session length, average packet size, etc.
 - Three various CPCH channel selection algorithms.
- The following traffic model is used in the simulations:
 - Average packet size: E-mail application 160, 480, 1000 bytes.
 - # of packets in a packet call = 15.
 - Packet call inter-arrival time = 0,120.
 - # of packet calls within a session =1.
 - Average inter-packet arrival time = 30, 100, 200 ms.
 - CPCH channel data rates: 2.048 Msps (512 kbps), 384 ksps (96 kbps), 144 ksps (36 kbps), 64 ksps (16 kbps).
 - Session arrival = Poisson.
- The following results are captured:
 - End-to-End Delay, D(e-e), includes UL retransmissions and DL ACK transmission.
 - Unacknowledged Mode End-to-End Delay, D(un).
 - RLC queuing delay, QD.
 - Radio Access Delay, AD.
 - MAC collisions, event count for event in which 2 UE attempt access to same CPCH channel in same slot.

- Throughput (S1) includes ARQ re-transmissions/ excludes detected MAC collisions/excludes undetected collisions as well.
- Unacknowledged Mode Throughput (S2) excludes ARQ re-transmissions / excludes MAC collisions.
- Offered Load (ρ), total offered traffic normalised to total available capacity (bandwidth).
- Undetected collisions per sec.
- Detected collisions per sec.

G.2 CPCH Channel Selection Algorithms

The three CPCH channel selection algorithms are: Simple, recency, idle-random.

G.2.1 Simple CPCH channel selection algorithm

In this method, the UE monitors the available capacity and the highest available rate from the Base Node. The UE then picks a CPCH channel and a slot randomly and contends for the CPCH.

G.2.2 The recency table method

In this method, the UE monitors the AP-AICH and constructs a recency table, which includes time-stamps, which aid the selection of the CPCH channel. The simulation assumes perfect knowledge of the transmission of AP-AICH (CPCH channel transition from idle to busy) from the base Node. In reality, there will be discrepancies in the information in the table since the UE is required to receive FACH and DL-DPCCH (while transmitting on the UL CPCH) and thus will may not be able to receive all AP-AICHs. The UE selects the CPCH channel with the oldest AP-AICH timestamp.

G.2.3 The idle-random method

In this method, the UE monitors the idle-AICH (channel idle) and AP-AICH (channel busy) and has perfect information on the availability of the CPCH channels. The UE monitors the AP-AICH and CD-AICH for 10 ms. then it picks a CPCH channel randomly from the available ones in the desired data rate category. Note that this method is sensitive to back-off methods. When the traffic load is high and there are multiple CPCH channels, this method outperforms the other methods given the right back-off parameters.

G.3 Simulation Results

G.3.1 Cases A-B: Comparison of idle-random method and the recency method for 30 ms packet inter-arrival time, 480 bytes, and 6 CPCH channels, each @384 ksps

36 cases were ran over to compare the throughput delay performance of the two methods when the packet inter-arrival time is 30 ms. This was done for various packet lengths (158 bytes, 480 bytes, 1000 bytes, 2000 bytes), various rates (6 CPCH @ 384 ksps, 16 CPCH @ 144 ksps, 32 CPCH @ 64 ksps), various N_Max_Frames (8,16,24,32,64), and the three CPCH channel selection algorithms. In all cases, the idle-random method performed better. When the packet inter-arrival time was increased, the throughput delay performance of the recency method almost overlapped with the idle-random case (see Scenarios C-D-E).

Results presented here compare idle-random method and the recency method for 30 ms packet inter-arrival time, 480 bytes, and 6 CPCH @384 ksps:

Table G-1: Idle random case

α	S1	D(e-e)
.34	.33	.3
.44	.42	.338
.53	.5	.375
.65	.70	.430
.95	.76	.92

Table G-2: Recency table case

α	S1	D(e-e)
.36	.335	.36
.45	.42	.375
.67	.583	.55
.97	.76	1.73

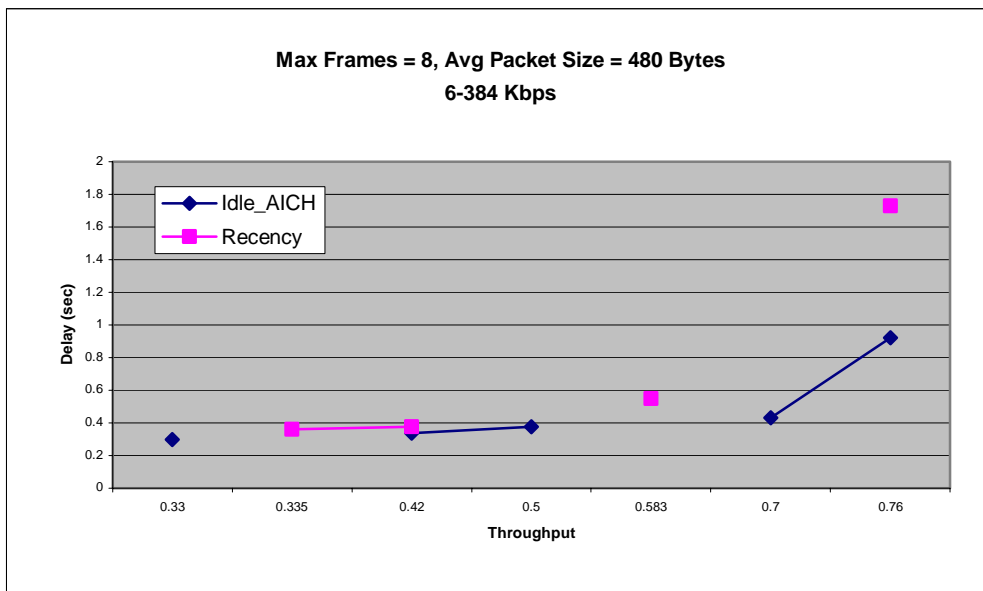

Figure G-1: Delay vs. Throughput

G.3.2 Case C-D-E: Comparison of the three methods for multiple CPCH

Recency table and the idle random methods out-perform the simple case significantly. However, the recency method performs almost as well as the idle-random case in these simulation runs for two reasons: 1) the recency table case in the simulation does not have any discrepancies in its information 2) the back-off for idle-random is not optimised and therefore it performs slightly worse when the packet inter-arrival time is high (e.g., 100 ms).

At D (un) of 300 ms, we have the following throughputs:

Simple case, S1 = .55.

Recency table: S1 = .8.

Idle-random S1 = .78.

Table G-3, Table G-4, Table G-5 provide results for the comparison of the three CPCH channel selection algorithms considering:

Packet inter-arrival time 100 ms.

Maximum frame per packet 8.

Average packet size 480.

12 channels: 4 – 384 CPCH; 4 – 144 CPCH; 4 – 64 CPCH.

Table G-3: E-mail_1_with the simple algorithm

Sess	ρ	S1	D(un)	QD	AD	TD	MAC Collision
20	0.310	0.280	0.121	0.070	0.013	0.038	677,000.000
16	0.390	0.360	0.155	0.100	0.015	0.039	106,000.000
10	0.630	0.550	0.300	0.237	0.020	0.042	266,000.000
8	0.776	0.650	0.660	0.589	0.025	0.045	436,700.000
6.8	0.923	0.76	1.324	1.245	0.033	0.046	714,700.000
6.6	1.00	0.812	3.23	3.15	0.036	0.047	983,300.000

Table G-4: E-mail_1_with the recency table algorithm

Sess	ρ	S1	D(un)	QD	AD	TD	MAC Collision
20	0.283	0.280	0.110	0.062	0.009	0.038	96,500.000
16	0.380	0.377	0.116	0.069	0.010	0.038	162,000.000
12	0.477	0.470	0.131	0.081	0.012	0.038	251,000.000
10	0.566	0.565	0.140	0.088	0.014	0.038	354,700.000
8	0.779	0.736	0.203	0.149	0.016	0.038	733,300.000
7.1	0.846	0.800	0.290	0.235	0.017	0.038	860,000.000

Table G-5: E-mail_1_with the idle random algorithm

Sess	ρ	S1	D(un)	QD	AD	TD	MAC Collision
20	0.282	0.280	0.102	0.056	0.007	0.039	65,100.000
16	0.351	0.350	0.118	0.072	0.007	0.039	89,000.000
12	0.458	0.454	0.124	0.076	0.008	0.040	137,500.000
10	0.558	0.554	0.148	0.109	0.008	0.041	215,000.000
8	0.667	0.657	0.211	0.160	0.009	0.042	344,000.000
7.1	0.741	0.736	0.260	0.208	0.010	0.043	472,000.000
6.5	0.825	0.800	0.350	0.296	0.012	0.043	644,000.000
6.3	0.876	0.837	0.544	0.488	0.013	0.043	765,300.000

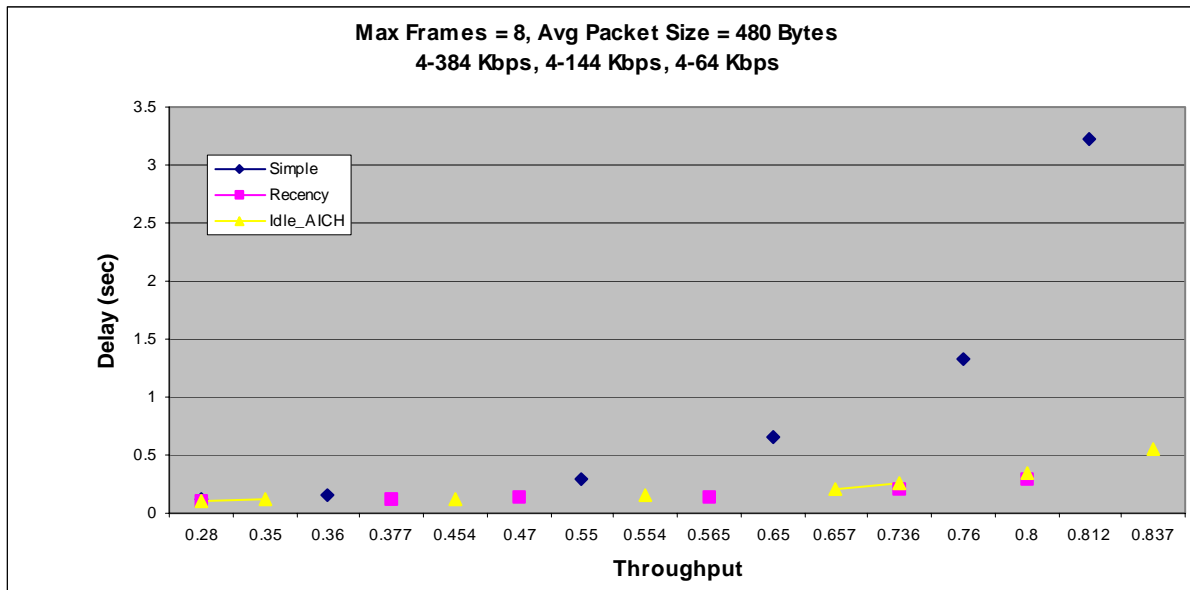

Figure G-2: Delay vs. Throughput

G.3.3 Cases E-F: Impact of packet inter-arrival time

Increasing the packet inter-arrival time from 100 to 200 ms, the throughput delay performance improves significantly. Increasing the packet inter-arrival time, the packet model resembles the Poisson arrival model more. The motivation to increase the packet inter-arrival time to improve the overall delay performance of all methods. This can be achieved in practice by having the TFCI and being able to send more packets during a single CPCH transmission if it arrives in the RLC buffer. This is quite possible from a single logical channel. Both Table 19.6 and Table 19.7 provide results for:

Idle Random Algorithm.

Average packet size 480.

16 CPCH channels: 4 – 384 CPCH; 4 – 144 CPCH; 4 – 64 CPCH.

Case E (Table G-6) corresponds to packet inter-arrival time of 100 ms presented in the previous subclause (Table G-5), which is repeated here for convenience. Table G-7 addresses the case of 200 ms packet arrival time.

Table G-6: E-mail_1_with idle random algorithm

Sess	ρ	S1	D(un)	QD	AD	TD	MAC Collision
20	0.282	0.280	0.102	0.056	0.007	0.039	65,100.000
16	0.351	0.350	0.118	0.072	0.007	0.039	89,000.000
12	0.458	0.454	0.124	0.076	0.008	0.040	137,500.000
10	0.558	0.554	0.148	0.109	0.008	0.041	215,000.000
8	0.667	0.657	0.211	0.160	0.009	0.042	344,000.000
7.1	0.741	0.736	0.260	0.208	0.010	0.043	472,000.000
6.5	0.825	0.800	0.350	0.296	0.012	0.043	644,000.000
6.3	0.876	0.837	0.544	0.488	0.013	0.043	765,300.000

Table G-7: E-mail_3_with idle random algorithm

Sess	ρ	S1	D(un)	QD	AD	TD	MAC Collision
20	0.275	0.273	0.067	0.022	0.007	0.038	61,600
16	0.329	0.326	0.074	0.028	0.007	0.039	81,900
10	0.470	0.467	0.076	0.029	0.008	0.040	152,700
8	0.558	0.554	0.079	0.031	0.008	0.041	233,300
7	0.616	0.610	0.091	0.041	0.009	0.042	300,000
6.5	0.656	0.647	0.142	0.091	0.009	0.042	345,300
6.3	0.681	0.673	0.112	0.061	0.009	0.042	388,000
4.95	0.819	0.79	0.178	0.123	0.012	0.043	637,000
4.9	0.867	0.824	0.205	0.148	0.014	0.043	746,700

G.3.4 Case G: Number of mobiles in a cell

There could potentially be hundreds of UEs in parallel session as shown by the table in this case. In third case, there are 930 UEs in parallel session if 25% of the capacity was allocated to Packet Data services. Idle-Random CPCH channel is used. There are 6 CPCH channels @ 384ksp which is equivalent to 25% of cell capacity. Table G-8 addresses the case of 200 ms packet inter-arrival time.

Table G-8: Delay vs. Number of UEs @ 25% of cell

Mobiles	ρ	S1	D(un)	QD	AD	TD	MAC Coll
318	.257	.256	.08	.031	.011	.038	55,766
750	.609	.604	.137	.078	.017	.042	300,000
930	.798	.772	.241	.175	.022	.044	595,000

G.3.5 Case H-I: Comparison of recency and idle-random methods for single CPCH

The recency method outperforms the random-idle for a single CPCH case and high inter-arrival time of 200 ms as shown by tables in cases F and G. The reason for this is the non-optimised back-off mechanism for the random-idle case. Table G-9 and Table G-10 compare recency and idle-random methods assuming a single 2 Msps CPCH, 200 ms packet inter-arrival, 480 bytes messages.

Table G-9: Idle-random method

ρ	S1	D(un)	QD	AD	TD	MAC Coll
.56	.535	.23	.171	.0448	.0137	200,833
.768	.684	.97	.883	.0729	.0137	398,000

Table G-10: Recency Table method

ρ	S1	D(un)	QD	AD	TD	MAC Coll
.574	.634	.0927	.057	.022	.0137	153,333
.813	.675	.131	.086	.031	.0136	318,666

G.3.6 Case H and J: Comparison of single CPCH and multiple CPCH, idle-random at 2 Msps

As can be seen from the table the multiple CPCH case performs significantly better than the single CPCH case. Note that the packet length in the multiple CPCH case is 1000 bytes whereas in the single CPCH case it is 480 bytes. This case outperforms the single CPCH channel with the recency method as well (Case I). Table G-11 refers to the idle-random method in case of single 2 Msps CPCH, 200 ms packet inter-arrival, 480 bytes messages; Table G-12 refers to the same methods but considering 4 CPCH @ 2Msps, 300 ms inter-arrival time, 1000 byte messages.

Table G-11: Single CPCH with 200 ms packet inter-arrival

\square	\square S1	D(un)	QD	AD	TD	MAC Coll
.56	.535	.23	.171	.0448	.0137	200,833
.768	.684	.97	.883	.0729	.0137	398,000

Table G-12: Multiple CPCH with 300 ms packet inter arrival

\square	S1	D(un)	QD	AD	TD	MAC Coll
.57	.61	.067	.02	.012	.035	6.35 %
.76	.71	.096	.045	.016	.035	14.6%
.82	.75	.104	.05	.019	.035	18.1%
.88	.76	.171	.115	.021	.035	20%
.93	.8	.242	.184	.023	.035	23%
.975	.81	.367	.28	.025	.035	25%

G.4 Discussion on idle-AICH and use of TFCI

As the packet inter-arrival time decreases, the throughput delay performance of all the CPCH channel selection algorithms degrades. At low packet inter-arrival times, the idle-random method clearly out-performs the recency method. The simple method performs worst in all cases. When the packet-inter-arrival time increases to 100-200 ms, then the recency method performs similar to the idle-random case. Note that at high packet inter-arrival times (very low channel loading), the throughput delay performance of all cases improves significantly. In reality, if we do not have fixed packet length and let the UE transmit the incoming packets from the higher layer midst the CPCH transmission, then the packet inter-arrival times will be higher values. By optimising the random-idle case with appropriate back-off mechanism and incorporating the impact of the discrepancies in the recency table, the random-idle case will perform better at high packet inter-arrival times as well. So, we propose adoption of use of idle-AICH to provide for more knowledge of the CPCH channel usage.

G.5 Recommended RRM Strategies

- Use the idle-AICH channel selection algorithm to improve the performance when the packet inter-arrival time is small.
- Use of TFCI is recommended so that the packet arrival process become less clustered and approach the Poisson statistics. This will ensure better throughput delay performance.

Annex H:

Examples of RACH/PRACH Configuration

This appendix illustrates examples of RACH/PRACH configurations in a cell.

H.1 Principles of RACH/PRACH Configuration

In one cell, several RACHs and PRACHs may be configured by an operator, in order to meet the performance requirements in regard to the expected traffic volume. The model of RACH and PRACH described in [5] defines a one-to-one mapping between a certain RACH and a PRACH.

The RACHs mapped to the PRACHs may all employ the same Transport Format and Transport Format Combination Sets, respectively. It is however also possible that individual RACH Transport Format Sets are applied on each available RACH/PRACH. The parameters that define pairs of RACH and PRACH are specified in [9], in the information element "PRACH system information list".

The "PRACH system information list" IE defines sets of "PRACH system information", one for each pair of RACH and PRACH that shall be configured in a cell. The "PRACH system information list" IE is included in SIB 5 and SIB 6. The total number of configured RACH/PRACH pairs corresponds to the sum of PRACH system information multiplicity factors used in both SIB5 and SIB 6.

A PRACH could therefore be defined in a pragmatic way simply as a common uplink physical channel, which is indicated in system information. It is straightforward for the UE to count the indicated RACH/PRACH pairs, perform a selection and configure itself for accessing the selected channel. There are however some restrictions on the choice of parameters to be included in PRACH system information. Restrictions are especially due to the requirement that the PRACH receiver in the Node B must be capable to identify unambiguously on which PRACH a random access is received. This is necessary to perform the mapping of the decoded PRACH message part to the correct RACH transport channel associated with the PRACH. For complexity reasons it is furthermore a desired feature that PRACH identification in FDD mode is completed in the preamble transmission phase in order to decode the PRACH message part, which follows the preamble, as generally there might be different transport format parameters defined on each RACH.

Taking into account the above requirements, the RACH/PRACH model allows to configure different PRACHs in the following two ways:

1. For each PRACH indicated in system information a different preamble scrambling code is employed in FDD and a different timeslot is employed in TDD. For each PRACH, sets of "available signatures" in FDD or "available channelisation codes" in TDD, and "available subchannel numbers" are defined in the "PRACH info (for RACH)" Information Element in [9]. Any PRACH with an individual scrambling code in FDD or individual timeslot in TDD may employ the complete or a subset of signatures in FDD or channelisation codes in TDD, and subchannels.
2. Two (or more) PRACHs indicated in system information use a common preamble scrambling code in FDD and common timeslot in TDD. In this case each PRACH shall employ a distinct (non-overlapping) set of "available signatures" in FDD or "available channelisation codes" in TDD, and "available subchannel numbers" in order to enable Node B to identify from the received random access signal which PRACH and respective RACH is used.

Figure H.1 for FDD and H.2 for TDD show examples of suitable RACH/PRACH configurations for one cell. The upper part of the figure illustrates the one-to-one mapping between a RACH and a PRACH. In FDD each RACH is specified via an individual Transport Format Set (TFS). The associated PRACH employs a Transport Format Combination Set (TFCS), with each TFC in the set corresponding to one specific TF of the RACH. In TDD each RACH/PRACH combination supports a single TF with the associated TFS. The maximum number of PRACH per cell is currently limited to 16. The maximum number of RACHs must be the same due to the one-to-one correspondence between a RACH and a PRACH.

With each PRACH, in FDD a scrambling code is associated, and in TDD a single timeslot is associated. [9] allows to address 16 different scrambling codes in FDD. Also, to each PRACH a set of "available subchannels" and "available signatures" in FDD or "available channelisation codes" in TDD is assigned.

For each PRACH a set of up to eight "PRACH partitions" can be defined for establishment of Access Service Classes (ASCs). A PRACH partition is defined as the complete or a subset of the "available signatures" in FDD or "available channelisation codes" in TDD, and "available subchannel numbers" defined for one PRACH. An ASC consists of a PRACH partition and a persistence value. PRACH partitions employed for ASC establishment may be overlapping (note that Figure H.1 and H2 only illustrates cases of non-overlapping PRACH partitions).

PRACH 0 and PRACH 1 in Figure H.1 employ the full set of PRACH subchannels and preamble signatures and are identified by using different preamble scrambling codes. Similarly in figure H.2 PRACH 0 & 1 employ the full set of PRACH subchannels and channelisation codes and are identified by using different timeslots.

PRACH 2 and PRACH 3 illustrate a configuration where a common scrambling code in FDD (figure H.1) and a common timeslot timeslot in TDD (figure H.2) but distinct (non-overlapping) partitions of "available subchannels" and "available signatures" in FDD and "available channelisation codes" in TDD are assigned. This configuration in FDD may e.g. be appropriate for establishment of two RACH/PRACH pairs, one with 10 and the other with 20 ms TTI.

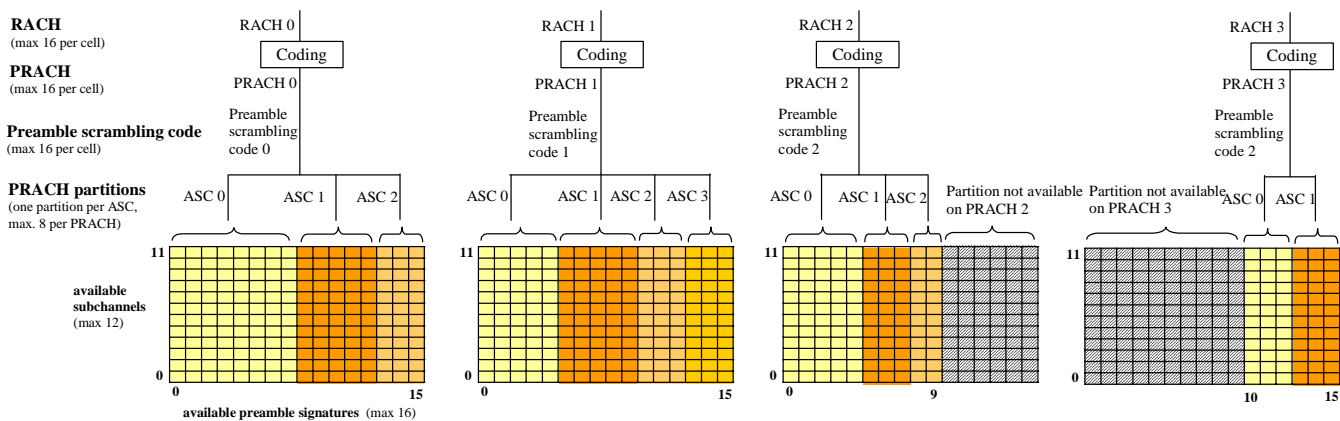

Figure H.1: Examples of FDD RACH/PRACH configurations in a cell

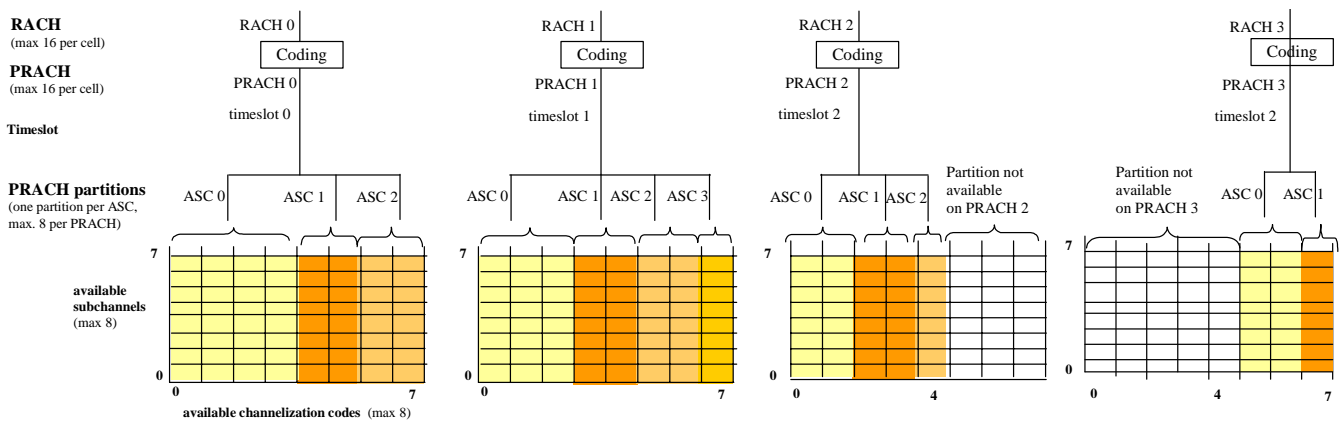

Figure H.2: Examples of TDD RACH/PRACH configurations in a cell

NOTE 1: ASC partitions by subchannel are possible but not shown.

NOTE 2: TDD example shows 8 subchannels. In TDD 1, 2, and 4 subchannels are also possible. Description of TDD subchannels can be found in [17].

Annex I: Example of PCPCH assignment with VCAM

This subclause illustrates an example of PCPCH assignment using the mapping rule specified in [9] for the Versatile Channel Assignment Method (VCAM) for the case that the number of PCPCHs, K, is larger than 16.

Table I-1 shows the mapping of pairs of AP signature/subchannel numbers and CA signature numbers to PCPCH indices k. In the shown example the number of minimum available spreading factors is set to R = 2, and the number of PCPCHs is K=21.

Table I-1: Example of PCPCH assignment with VCAM

PCPCH (k)	A ₀ = 128			A ₁ = 256			
	AP ₀ (AP ₀), CA ₀	AP ₂ (AP ₁), CA ₇	AP ₁ (AP ₂), CA ₁₄	AP ₀ (AP ₃), CA ₀	AP ₁ (AP ₄), CA ₅	AP ₂ (AP ₅), CA ₁₀	AP ₃ (AP ₆), CA ₁₅
0	AP ₀ (AP ₀), CA ₀	AP ₂ (AP ₁), CA ₇	AP ₁ (AP ₂), CA ₁₄	AP ₀ (AP ₃), CA ₀	AP ₁ (AP ₄), CA ₅	AP ₂ (AP ₅), CA ₁₀	AP ₃ (AP ₆), CA ₁₅
1	AP ₁ (AP ₁), CA ₀	AP ₀ (AP ₂), CA ₇	AP ₂ (AP ₀), CA ₁₄	AP ₁ (AP ₄), CA ₀	AP ₂ (AP ₅), CA ₅	AP ₃ (AP ₆), CA ₁₀	
2	AP ₂ (AP ₂), CA ₀	AP ₁ (AP ₀), CA ₇	AP ₀ (AP ₁), CA ₁₄	AP ₂ (AP ₅), CA ₀	AP ₃ (AP ₆), CA ₅	AP ₀ (AP ₃), CA ₁₁	
3	AP ₀ (AP ₀), CA ₁	AP ₂ (AP ₁), CA ₈	AP ₁ (AP ₂), CA ₁₅	AP ₃ (AP ₆), CA ₀	AP ₀ (AP ₃), CA ₆	AP ₁ (AP ₄), CA ₁₁	
4	AP ₁ (AP ₁), CA ₁	AP ₀ (AP ₂), CA ₈	AP ₂ (AP ₀), CA ₁₅	AP ₀ (AP ₃), CA ₁	AP ₁ (AP ₄), CA ₆	AP ₂ (AP ₅), CA ₁₁	
5	AP ₂ (AP ₂), CA ₁	AP ₁ (AP ₀), CA ₈	AP ₀ (AP ₁), CA ₁₅	AP ₁ (AP ₄), CA ₁	AP ₂ (AP ₅), CA ₆	AP ₃ (AP ₆), CA ₁₁	
6	AP ₀ (AP ₀), CA ₂	AP ₂ (AP ₁), CA ₉		AP ₂ (AP ₅), CA ₁	AP ₃ (AP ₆), CA ₆	AP ₀ (AP ₃), CA ₁₂	
7	AP ₁ (AP ₁), CA ₂	AP ₀ (AP ₂), CA ₉		AP ₃ (AP ₆), CA ₁	AP ₀ (AP ₃), CA ₇	AP ₁ (AP ₄), CA ₁₂	
8	AP ₂ (AP ₂), CA ₂	AP ₁ (AP ₀), CA ₉		AP ₀ (AP ₃), CA ₂	AP ₁ (AP ₄), CA ₇	AP ₂ (AP ₅), CA ₁₂	
9	AP ₀ (AP ₀), CA ₃	AP ₂ (AP ₁), CA ₁₀		AP ₁ (AP ₄), CA ₂	AP ₂ (AP ₅), CA ₇	AP ₃ (AP ₆), CA ₁₂	
10	AP ₁ (AP ₁), CA ₃	AP ₀ (AP ₂), CA ₁₀		AP ₂ (AP ₅), CA ₂	AP ₃ (AP ₆), CA ₇	AP ₀ (AP ₃), CA ₁₃	
11	AP ₂ (AP ₂), CA ₃	AP ₁ (AP ₀), CA ₁₀		AP ₃ (AP ₆), CA ₂	AP ₀ (AP ₃), CA ₈	AP ₁ (AP ₄), CA ₁₃	
12	AP ₀ (AP ₀), CA ₄	AP ₂ (AP ₁), CA ₁₁		AP ₀ (AP ₃), CA ₃	AP ₁ (AP ₄), CA ₈	AP ₂ (AP ₅), CA ₁₃	
13	AP ₁ (AP ₁), CA ₄	AP ₀ (AP ₂), CA ₁₁		AP ₁ (AP ₄), CA ₃	AP ₂ (AP ₅), CA ₈	AP ₃ (AP ₆), CA ₁₃	
14	AP ₂ (AP ₂), CA ₄	AP ₁ (AP ₀), CA ₁₁		AP ₂ (AP ₅), CA ₃	AP ₃ (AP ₆), CA ₈	AP ₀ (AP ₃), CA ₁₄	
15	AP ₀ (AP ₀), CA ₅	AP ₂ (AP ₁), CA ₁₂		AP ₃ (AP ₆), CA ₃	AP ₀ (AP ₃), CA ₉	AP ₁ (AP ₄), CA ₁₄	
16	AP ₁ (AP ₁), CA ₅	AP ₀ (AP ₂), CA ₁₂		AP ₀ (AP ₃), CA ₄	AP ₁ (AP ₄), CA ₉	AP ₂ (AP ₅), CA ₁₄	
17	AP ₂ (AP ₂), CA ₅	AP ₁ (AP ₀), CA ₁₂		AP ₁ (AP ₄), CA ₄	AP ₂ (AP ₅), CA ₉	AP ₃ (AP ₆), CA ₁₄	
18	AP ₀ (AP ₀), CA ₆	AP ₂ (AP ₁), CA ₁₃		AP ₂ (AP ₅), CA ₄	AP ₃ (AP ₆), CA ₉	AP ₀ (AP ₃), CA ₁₅	
19	AP ₁ (AP ₁), CA ₆	AP ₀ (AP ₂), CA ₁₃		AP ₃ (AP ₆), CA ₄	AP ₀ (AP ₃), CA ₁₀	AP ₁ (AP ₄), CA ₁₅	
20	AP ₂ (AP ₂), CA ₆	AP ₁ (AP ₀), CA ₁₃		AP ₀ (AP ₃), CA ₅	AP ₁ (AP ₄), CA ₁₀	AP ₂ (AP ₅), CA ₁₅	

NOTE:

- SF (A₀) = 128, Number of AP (S₀) = 3: Re-numbered AP0 = AP₀, AP1 = AP₁, AP2 = AP₂

- $SF(A_1) = 256$, Number of AP (S_1) = 4: Re-numbered AP3 = AP₀, AP4 = AP₁, AP5 = AP₂, AP6 = AP₃
- $P_0 = P_1 = 21$
- $T_0 = T_1 = 16$.
- In this example, $M_0 = 7$, $M_1 = 21$

Annex J: Change history

Change history							
Date	TSG #	TSG Doc.	CR	Rev	Subject/Comment	Old	New
12/1999	RP-06	RP-99661	-		Approved at TSG-RAN #6 and placed under Change Control	-	3.0.0
03/2000	RP-07	RP-000049	001		PDSCH code usage and signalling	3.0.0	3.1.0
06/2000	RP-08	RP-000228	003	1	Stage 2 description for Handover to UTRAN	3.1.0	3.2.0
09/2000	RP-09	RP-000366	004	2	Clarification on RRC security and capability information transfer during handover to UTRAN	3.2.0	3.3.0
	RP-09	RP-000366	006		Variable Rate Transmission	3.2.0	3.3.0
12/2000	RP-10	RP-000576	008		PRACH/RACH configuration	3.3.0	3.4.0
	RP-10	RP-000576	009	1	Example of VCAM mapping rule	3.3.0	3.4.0
	RP-10	RP-000576	010	1	Predefined configurations for R'99	3.3.0	3.4.0
	RP-10	RP-000576	011		Utilisation of compressed mode for BSIC reconfirmation	3.3.0	3.4.0
03/2001	RP-11	RP-010034	012	1	Principles of RACH/PRACH Configuration in TDD	3.4.0	3.5.0
	RP-11	RP-010034	013	1	Radio Bearer Control corrections	3.4.0	3.5.0
	RP-11	RP-010034	014		Correction to idle mode tasks	3.4.0	3.5.0
	RP-11	-	-		Upgrade to Release 4 - no technical change	3.5.0	4.0.0
09/2001	RP-13	RP-010552	016		Update of preconfiguration description	4.0.0	4.1.0
	RP-13	RP-010552	018		Alignment with 25.304	4.0.0	4.1.0
03/2002	RP-15	RP-020076	020		Clarification regarding the transfer of RRC information across interfaces other than Uu	4.1.0	4.2.0
	RP-15	RP-020076	022		Correction to TDD DCA Description	4.1.0	4.2.0

History

Document history		
V4.0.0	March 2001	Publication
V4.1.0	September 2001	Publication
V4.2.0	March 2002	Publication