

Universal Mobile Telecommunications System (UMTS); Radio resource management strategies (3GPP TR 25.922 version 3.3.0 Release 1999)



Reference

RTR/TSGR-0225922UR3

Keywords

UMTS

ETSI

650 Route des Lucioles
F-06921 Sophia Antipolis Cedex - FRANCE

Tel.: +33 4 92 94 42 00 Fax: +33 4 93 65 47 16

Siret N° 348 623 562 00017 - NAF 742 C
Association à but non lucratif enregistrée à la
Sous-Préfecture de Grasse (06) N° 7803/88

Important notice

Individual copies of the present document can be downloaded from:

<http://www.etsi.org>

The present document may be made available in more than one electronic version or in print. In any case of existing or perceived difference in contents between such versions, the reference version is the Portable Document Format (PDF). In case of dispute, the reference shall be the printing on ETSI printers of the PDF version kept on a specific network drive within ETSI Secretariat.

Users of the present document should be aware that the document may be subject to revision or change of status. Information on the current status of this and other ETSI documents is available at <http://www.etsi.org/tb/status/>

If you find errors in the present document, send your comment to:
editor@etsi.fr

Copyright Notification

No part may be reproduced except as authorized by written permission.
The copyright and the foregoing restriction extend to reproduction in all media.

© European Telecommunications Standards Institute 2000.

All rights reserved.

Intellectual Property Rights

IPRs essential or potentially essential to the present document may have been declared to ETSI. The information pertaining to these essential IPRs, if any, is publicly available for **ETSI members and non-members**, and can be found in ETSI SR 000 314: "*Intellectual Property Rights (IPRs); Essential, or potentially Essential, IPRs notified to ETSI in respect of ETSI standards*", which is available from the ETSI Secretariat. Latest updates are available on the ETSI Web server (<http://www.etsi.org/ipr>).

Pursuant to the ETSI IPR Policy, no investigation, including IPR searches, has been carried out by ETSI. No guarantee can be given as to the existence of other IPRs not referenced in ETSI SR 000 314 (or the updates on the ETSI Web server) which are, or may be, or may become, essential to the present document.

Foreword

This Technical Report (TR) has been produced by the ETSI 3rd Generation Partnership Project (3GPP).

The present document may refer to technical specifications or reports using their 3GPP identities, UMTS identities or GSM identities. These should be interpreted as being references to the corresponding ETSI deliverables.

The cross reference between GSM, UMTS, 3GPP and ETSI identities can be found under www.etsi.org/key .

Contents

Foreword.....	6
1 Scope	7
2 References	7
3 Definitions and abbreviations.....	7
3.1 Definitions	7
3.2 Abbreviations	7
4 Idle Mode Tasks	9
4.1 Service type in Idle mode	9
4.2 Criteria for Cell Selection and Reselection	9
4.2.1 Cell Selection Criteria.....	9
4.2.2 Immediate Cell Evaluation	9
4.2.3 Cell Re-selection.....	10
4.3 Location Registration	10
5 RRC Connection Mobility	10
5.1 Handover	10
5.1.1 Strategy.....	10
5.1.2 Causes.....	10
5.1.3 Hard Handover.....	11
5.1.4 Soft Handover.....	11
5.1.4.1 Soft Handover Parameters and Definitions	11
5.1.4.2 Example of a Soft Handover Algorithm.....	12
5.1.4.3 Soft Handover Execution	13
5.1.5 Inter Radio Access Technology Handover	14
5.1.5.1 Handover 3G to 2G	14
5.1.5.2 Handover 2G to 3G	14
5.1.5.2.1 Introduction	14
5.1.5.2.2 Predefined radio configuration information	14
5.1.5.2.3 Security and UE capability information	15
5.1.5.2.4 UE capability information	15
5.1.5.2.5 Handover to UTRAN information flows, typical example.....	15
5.1.6 Measurements for Handover.....	18
5.1.6.1 Monitoring of FDD cells on the same frequency	18
5.1.6.2 Monitoring cells on different frequencies	18
5.1.6.2.1 Monitoring of FDD cells on a different frequency	18
5.1.6.2.2 Monitoring of TDD cells	18
5.1.6.2.2.2 Setting of compressed mode parameters with prior timing information between FDD serving cell and TDD target cells.....	19
5.1.6.2.3 Monitoring of GSM cells.....	19
6 Admission Control	21
6.1 Introduction	21
6.2 Examples of CAC strategies.....	21
6.3 Scenarios	22
6.3.1 CAC performed in SRNC.....	22
6.3.2 CAC performed in DRNC	23
6.3.2.1 Case of DCH.....	23
6.3.2.2 Case of Common Transport Channels.....	23
7 Radio Bearer Control	24
7.1 Usage of Radio Bearer Control procedures.....	24
7.1.1 Examples of Radio Bearer Setup	24
7.1.2 Examples of Physical Channel Reconfiguration.....	25
7.1.2.1 Increased UL data, with switch from RACH/FACH to DCH/DCH.....	25
7.1.2.2 Increased DL data, no Transport channel type switching	26
7.1.2.3 Decrease DL data, no Transport channel type switching	26

7.1.2.4	Decreased UL data, with switch from DCH/DCH to RACH/FACH	26
7.1.3	Examples of Transport Channel Reconfiguration.....	27
7.1.3.1	Increased UL data, with no transport channel type switching.....	27
7.1.3.2	Decreased DL data, with switch from DCH/DCH to RACH/FACH	28
7.1.4	Examples of Radio Bearer Reconfiguration	28
8	Dynamic Resource Allocation	29
8.1	Code Allocation Strategies for FDD mode.....	29
8.1.1	Introduction.....	29
8.1.2	Criteria for Code Allocation	30
8.1.3	Example of code Allocation Strategies.....	30
8.1.4	PDSCH code management.....	31
8.2	DCA (TDD)	33
8.2.1	Channel Allocation	33
8.2.1.1	Resource allocation to cells (slow DCA)	33
8.2.1.2	Resource allocation to bearer services (fast DCA).....	34
8.2.2	Measurements Reports from UE to the UTRAN	34
9	Power Management.....	35
9.1	Variable Rate Transmission	35
9.1.1	Examples of Downlink Power Management	35
9.1.2	Examples of Uplink Power Management	35
9.2	Site Selection Diversity Power Control (SSDT)	35
9.3	Examples of balancing Downlink power.....	37
9.3.1	Adjustment loop.....	37
10	Radio Link Surveillance.....	37
10.1	Mode Control strategies for TX diversity.....	37
10.1.1	TX diversity modes.....	37
10.1.2	Mode Control Strategies	37
10.1.2.1	DPCH.....	37
10.1.2.2	Common channels.....	38
11	Codec mode control	38
11.1	AMR mode control.....	38
Annex A: Simulations on Fast Dynamic Channel Allocation.....		40
A.1	Simulation environment	40
A.2	Results	40
A.2.1	Macro UDD 144.....	40
A.2.2	Micro UDD 384	41
A.2.2.1	Code rate 1	41
A.2.2.2	Code rate 2/3.....	42
A.3	Conclusions	42
Annex B: Radio Bearer Control – Overview of Procedures: message exchange and parameters used.....		43
B.1	Examples of Radio Bearer Setup	43
B.1.1	RRC Parameters in RB Setup.....	43
B.1.2	RRC Parameters in RB Setup Complete	43
B.2	Examples of Physical Channel Reconfiguration	43
B.2.1	Increased UL data, with switch from RACH/FACH to DCH/DCH.....	44
B.2.1.1	RRC Parameters in Measurement Report	44
B.2.1.2	RRC Parameters in Physical Channel Reconfiguration	44
B.2.1.3	RRC Parameters in Physical Channel Reconfiguration Complete.....	44
B.2.2	Increased DL data, no Transport channel type switching.....	45
B.2.2.1	RRC Parameters in Physical Channel Reconfiguration	45
B.2.2.2	RRC Parameters in Physical Channel Reconfiguration Complete.....	45
B.2.3	Decrease DL data, no Transport channel type switching	45
B.2.3.1	RRC Parameters in Physical Channel Reconfiguration.....	45

B.2.3.2	RRC Parameters in Physical Channel Reconfiguration Complete.....	46
B.2.4	Decreased UL data, with switch from DCH/DCH to RACH/FACH.....	46
B.2.4.1	RRC Parameters in Physical Channel Reconfiguration	46
B.2.4.2	RRC Parameters in Physical Channel Reconfiguration Complete.....	46
B.3	Examples of Transport Channel Reconfiguration	46
B.3.1	Increased UL data, with no transport channel type switching.....	46
B.3.1.1	RRC Parameters in Measurement Report	47
B.3.1.2	RRC Parameters in Transport Channel Reconfiguration	47
B.3.1.3	RRC Parameters in Transport Channel Reconfiguration Complete.....	47
B.3.2	Decreased DL data, with switch from DCH/DCH to RACH/FACH.....	47
B.3.2.1	RRC Parameters in Transport Channel Reconfiguration	48
B.3.2.2	RRC Parameters in Transport Channel Reconfiguration Complete.....	48
B.4	Examples of RB Reconfiguration	48
B.4.1	RRC Parameters in Radio Bearer Reconfiguration	48
B.4.2	RRC Parameters in Radio Bearer Reconfiguration Complete.....	48
Annex C: Flow-chart of a Soft Handover algorithm.....		49
Annex D: SSDT performance.....		50
Annex E: Simulation results on DL Variable Rate Packet Transmission.....		51
E.1	Simulation assumption	51
E.2	Simulation results.....	51
Annex F: Simulation results on Adjustment loop.....		53
F.1	Simulation conditions.....	53
F.2	Simulation results.....	53
F.3	Interpretation of results	55
Annex G: Simulation results for CPCH		56
G.1	Simulation Assumptions	56
G.2	CPCH Channel Selection Algorithms	57
G.2.1	Simple CPCH channel selection algorithm	57
G.2.2	The recency table method.....	57
G.2.3	The idle-random method	57
G.3	Simulation Results.....	57
G.3.1	Cases A-B: Comparison of idle-random method and the recency method for 30 ms packet inter-arrival time, 480 bytes, and 6 CPCH channels, each @384 ksps.....	57
G.3.2	Case C-D-E: Comparison of the three methods for multiple CPCH	58
G.3.3	Cases E-F: Impact of packet inter-arrival time.....	60
G.3.4	Case G: Number of mobiles in a cell.....	61
G.3.5	Case H-I: Comparison of recency and idle-random methods for single CPCH	61
G.3.6	Case H and J: Comparison of single CPCH and multiple CPCH, idle-random at 2 Msps	62
G.4	Discussion on idle-AICH and use of TFCI	62
G.5	Recommended RRM Strategies	62
Annex H: Change history		63

Foreword

This Technical Report (TR) has been produced by the 3rd Generation Partnership Project (3GPP).

The contents of the present document are subject to continuing work within the TSG and may change following formal TSG approval. Should the TSG modify the contents of the present document, it will be re-released by the TSG with an identifying change of release date and an increase in version number as follows:

Version x.y.z

where:

- x the first digit:
 - 1 presented to TSG for information;
 - 2 presented to TSG for approval;
 - 3 or greater indicates TSG approved document under change control.
- y the second digit is incremented for all changes of substance, i.e. technical enhancements, corrections, updates, etc.
- z the third digit is incremented when editorial only changes have been incorporated in the document.

1 Scope

The present document shall describe RRM strategies supported by UTRAN specifications and typical algorithms.

2 References

The following documents contain provisions which, through reference in this text, constitute provisions of the present document.

- References are either specific (identified by date of publication, edition number, version number, etc.) or non-specific.
- For a specific reference, subsequent revisions do not apply.
- For a non-specific reference, the latest version applies.

- [1] 3GPP Homepage: www.3gpp.org.
- [2] 3GPP TS 25.212: "Multiplexing and channel coding".
- [3] 3GPP TS 25.215: "Physical layer – Measurements (FDD)".
- [4] 3GPP TS 25.301: "Radio Interface Protocol Architecture".
- [5] 3GPP TS 25.302: "Services provided by the Physical Layer".
- [6] 3GPP TS 25.303: "Interlayer Procedures in Connected Mode".
- [7] 3GPP TS 25.304: "UE procedures in Idle Mode and Procedures for Cell Reselection in Connected Mode".
- [8] 3GPP TS 25.322: "RLC Protocol Specification".
- [9] 3GPP TS 25.331: "RRC Protocol Specification".
- [10] 3GPP TS 25.921: "Guidelines and Principles for protocol description and error handling".
- [11] 3GPP TR 21.905: "Vocabulary for 3GPP Specifications".
- [12] 3GPP TS 26.010: "Mandatory Speech Codec speech processing functions AMR Speech Codec General Description".
- [13] 3GPP TS 23.022: "Functions related to Mobile Station (MS) in idle mode"
- [14] 3GPP TS 33.102: "3G Security; Security Architecture".

3 Definitions and abbreviations

3.1 Definitions

For the purposes of the present document, the terms and definitions given in [9] apply.

3.2 Abbreviations

For the purposes of the present document, the following abbreviations apply:

ARQ	Automatic Repeat Request
BCCH	Broadcast Control Channel

BCH	Broadcast Channel
C-	Control-
CC	Call Control
CCCH	Common Control Channel
CCH	Control Channel
CCTrCH	Coded Composite Transport Channel
CN	Core Network
CRC	Cyclic Redundancy Check
DC	Dedicated Control (SAP)
DCA	Dynamic Channel Allocation
DCCH	Dedicated Control Channel
DCH	Dedicated Channel
DL	Downlink
DRNC	Drift Radio Network Controller
DSCH	Downlink Shared Channel
DTCH	Dedicated Traffic Channel
FACH	Forward Link Access Channel
FAUSCH	Fast Uplink Signalling Channel
FCS	Frame Check Sequence
FDD	Frequency Division Duplex
GC	General Control (SAP)
HO	Handover
ITU	International Telecommunication Union
kbps	kilo-bits per second
L1	Layer 1 (physical layer)
L2	Layer 2 (data link layer)
L3	Layer 3 (network layer)
LAC	Link Access Control
LAI	Location Area Identity
MAC	Medium Access Control
MM	Mobility Management
Nt	Notification (SAP)
OCCCH	ODMA Common Control Channel
ODCCH	ODMA Dedicated Control Channel
ODCH	ODMA Dedicated Channel
ODMA	Opportunity Driven Multiple Access
ORACH	ODMA Random Access Channel
ODTCH	ODMA Dedicated Traffic Channel
PCCH	Paging Control Channel
PCH	Paging Channel
PDU	Protocol Data Unit
PHY	Physical layer
PhyCH	Physical Channels
RACH	Random Access Channel
RLC	Radio Link Control
RNC	Radio Network Controller
RNS	Radio Network Subsystem
RNTI	Radio Network Temporary Identity
RRC	Radio Resource Control
SAP	Service Access Point
SCCH	Synchronisation Control Channel
SCH	Synchronisation Channel
SDU	Service Data Unit
SRNC	Serving Radio Network Controller
SRNS	Serving Radio Network Subsystem
TCH	Traffic Channel
TDD	Time Division Duplex
TFCI	Transport Format Combination Indicator
TFI	Transport Format Indicator
TMSI	Temporary Mobile Subscriber Identity
TPC	Transmit Power Control
U-	User-

UE	User Equipment
UE _R	User Equipment with ODMA relay operation enabled
UL	Uplink
UMTS	Universal Mobile Telecommunications System
URA	UTRAN Registration Area
UTRA	UMTS Terrestrial Radio Access
UTRAN	UMTS Terrestrial Radio Access Network

4 Idle Mode Tasks

4.1 Service type in Idle mode

Services are distinguished into categories defined in [7]; also the categorisation of cells according to services they can offer is provided in [7].

In the following, some typical examples of the use of the different types of cells are provided:

- "Operator only" cell. The aim of this type of cell is to allow the operator using and test newly deployed cells without being disturbed by normal traffic.

4.2 Criteria for Cell Selection and Reselection

4.2.1 Cell Selection Criteria

The goal of the cell selection procedures is to fast find a cell to camp on. To speed up this process, at "power up" or when returning from "out of coverage", the UE shall start with the stored information from previous network contacts. If the UE is unable to find any of those cells the Initial cell search will be initiated.

If it is not possible to find a cell from a valid PLMN the UE will choose a cell in a forbidden PLMN and enter a "limited service state". In this state the UE regularly attempt to find a suitable cell on a valid PLMN. If a better cell is found the UE has to read the system information for that cell. The cell to camp on is chosen by the UE on link quality basis. However, the network can set cell re-selection thresholds in order to take other criteria into account, such as, for example:

- available services;
- cell load;
- UE speed.

In CDMA, it is important to minimise the UE output power, and also to minimise the power consumption in the UE.

In order to achieve that, an 'Immediate Cell Evaluation Procedure' at call set up can ensure that the UE transmits with the best cell, while keeping the power consumption low.

4.2.2 Immediate Cell Evaluation

It is important that the UE chooses the best cell (according to the chosen criteria) prior to a random access on the RACH. In idle mode, this applies to RRC message RRC Connection Request. This is the aim of the immediate cell evaluation. This procedure shall be fast and there shall not be any hysteresis requirements between the different cells. However, it must be possible to rank two neighbouring cells by means of an offset. This offset is unique between two cells. This implies that this value must be a part of the system information in the serving cell. This offset is introduced for system tuning purposes, in order to 'move' the 'cell border'.

Before the access on the RACH can be initiated the UE also needs to check the relevant parts of system information for making the access. The time it takes to perform an immediate cell evaluation and select a new cell is dependent on the time it takes to read the system information. This can be optimised by the scheduling of the system information at the

BCCH, the better scheduling the faster cell evaluation. In particular, at call set up, it would be important to select the optimal cell, i.e. the one where the UE uses the lowest output power.

4.2.3 Cell Re-selection

The cell reselection procedure is a procedure to check the best cell to camp on. The evaluation of the measurements for this procedure is always active, in idle mode, after the cell selection procedure has been completed and the first cell has been chosen. The goal of the procedure is to always camp on a cell with good enough quality even if it is not the optimal cell all the time.

It is also possible to have a time to trigger and hysteresis criteria in the cell reselection to control the number of cell reselections. The parameters needed for the cell reselection procedure (e.g., the offset value and the hysteresis) are unique on a cell to neighbour cell relation basis. These have therefore to be distributed, together with time to trigger value, in system information in the serving cell. This implies that the UE does not need to read the system information in the neighbouring cells before the cell reselection procedure finds a neighbouring cell with better quality.

4.3 Location Registration

The location registration procedure is defined in TS [13]. The strategy used for the update of the location registration has to be set by the operator and, for instance, can be done regularly and when entering a new registration area. The same would apply for the update of the NAS defined service area which can be performed regularly and when entering a new NAS defined service area.

5 RRC Connection Mobility

5.1 Handover

5.1.1 Strategy

The handover strategy employed by the network for radio link control determines the handover decision that will be made based on the measurement results reported by the UE/RNC and various parameters set for each cell. Network directed handover might also occur for reasons other than radio link control, e.g. to control traffic distribution between cells. The network operator will determine the exact handover strategies. Possible types of Handover are as follows:

- Handover 3G -3G;
- FDD soft/softer handover;
- FDD inter-frequency hard handover;
- FDD/TDD Handover;
- TDD/FDD Handover;
- TDD/TDD Handover;
- Handover 3G - 2G (e.g. Handover to GSM);
- Handover 2G - 3G (e.g. Handover from GSM).

5.1.2 Causes

The following is a non-exhaustive list for causes that could be used for the initiation of a handover process.

- Uplink quality;
- Uplink signal measurements;
- Downlink quality;

- Downlink signal measurements;
- Distance;
- Change of service;
- Better cell;
- O&M intervention;
- Directed retry;
- Traffic;
- Pre-emption.

5.1.3 Hard Handover

The hard handover procedure is described in [6].

Two main strategies can be used in order to determine the need for a hard handover:

- received measurements reports;
- load control.

5.1.4 Soft Handover

5.1.4.1 Soft Handover Parameters and Definitions

Soft Handover is an handover in which the mobile station starts communication with a new Node-B on a same carrier frequency, or sector of the same site (softer handover), performing utmost a change of code. For this reason Soft Handover allows easily the provision of macrodiversity transmission; for this intrinsic characteristic terminology tends to identify Soft Handover with macrodiversity even if they are two different concepts; for its nature soft handover is used in CDMA systems where the same frequency is assigned to adjacent cells. As a result of this definition there are areas of the UE operation in which the UE is connected to a number of Node-Bs. With reference to Soft Handover, the "Active Set" is defined as the set of Node-Bs the UE is simultaneously connected to (i.e., the UTRA cells currently assigning a downlink DPCH to the UE constitute the active set).

The Soft Handover procedure is composed of a number of single functions:

- Measurements;
- Filtering of Measurements;
- Reporting of Measurement results;
- The Soft Handover Algorithm;
- Execution of Handover.

The measurements of the monitored cells filtered in a suitable way trigger the reporting events that constitute the basic input of the Soft Handover Algorithm.

The definition of 'Active Set', 'Monitored set', as well as the description of all reporting events are given in TS 25.331.

Based on the measurements of the set of cells monitored, the Soft Handover function evaluates if any Node-B should be added to (Radio Link Addition), removed from (Radio Link Removal), or replaced in (Combined Radio Link Addition and Removal) the Active Set; performing than what is known as "Active Set Update" procedure.

5.1.4.2 Example of a Soft Handover Algorithm

A describing example of a Soft Handover Algorithm presented in this section which exploits reporting events 1A, 1B, and 1C described in TS 25.331. It also exploits the Hysteresis mechanism and the Time to Trigger mechanism described in TS 25.331. Any of the measurements quantities listed in TS 25.331 can be considered.

Other algorithms can be envisaged that use other reporting events described in TS 25.331; also load control strategies can be considered for the active set update, since the soft handover algorithm is performed in the RNC.

For the description of the Soft Handover algorithm presented in this section the following parameters are needed:

- AS_Th: Threshold for macro diversity (reporting range);
- AS_Th_Hyst: Hysteresis for the above threshold;
- AS_Rep_Hyst: Replacement Hysteresis;
- ΔT : Time to Trigger;
- AS_Max_Size: Maximum size of Active Set.

The following figure describes this Soft Handover Algorithm.

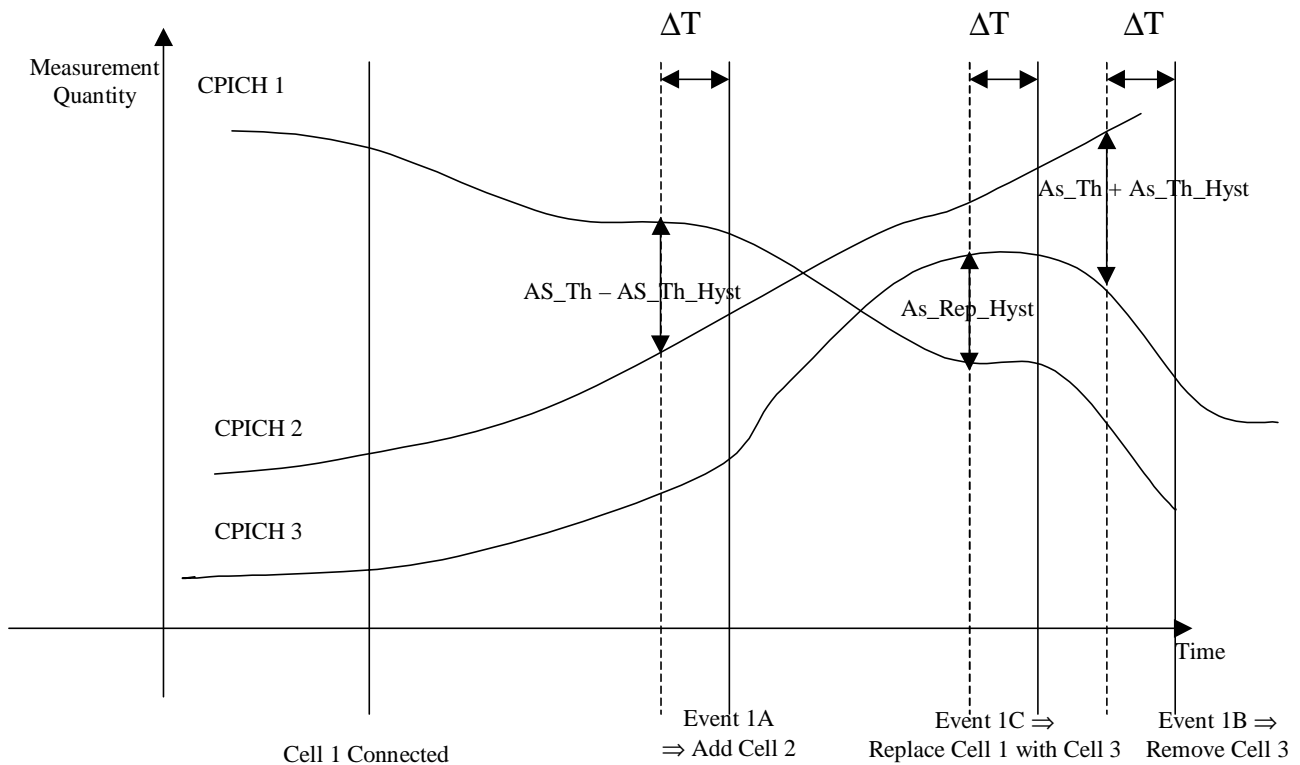

Figure 5-1: Example of Soft Handover Algorithm

As described in the figure above:

- If Meas_Sig is below $(Best_Ss - AS_Th - AS_Th_Hyst)$ for a period of ΔT remove Worst cell in the Active Set.
- If Meas_Sig is greater than $(Best_Ss - AS_Th + AS_Th_Hyst)$ for a period of ΔT and the Active Set is not full add Best cell outside the Active Set in the Active Set.
- If Active Set is full and Best_Cand_Ss is greater than $(Worst_Old_Ss + AS_Rep_Hyst)$ for a period of ΔT add Best cell outside Active Set and Remove Worst cell in the Active Set.

Where:

- Best_Ss :the best measured cell present in the Active Set;
- Worst_Old_Ss: the worst measured cell present in the Active Set;
- Best_Cand_Set:the best measured cell present in the monitored set.
- Meas_Sign :the measured and filtered quantity.

A flow-chart of the above described Soft Handover algorithm is available in Appendix C.

5.1.4.3 Soft Handover Execution

The Soft Handover is executed by means of the following procedures described in [6]:

- Radio Link Addition (FDD soft-add);
- Radio Link Removal (FDD soft-drop);
- Combined Radio Link Addition and Removal.

The serving cell(s) (the cells in the active set) are expected to have knowledge of the service used by the UE. The new cell decided to be added to the active set shall be informed that a new connection is desired, and it needs to have the following minimum information forwarded from the RNC:

- Connection parameters, such as coding schemes, number of parallel code channels etc. parameters which form the set of parameters describing the different transport channel configurations in use both uplink and downlink.
- The UE ID and uplink scrambling code.
- The relative timing information of the new cell, in respect to the timing UE is experiencing from the existing connections (as measured by the UE at its location). Based on this, the new Node-B can determine what should be the timing of the transmission initiated in respect to the timing of the common channels (CPICH) of the new cell.

As a response the UE needs to know via the existing connections:

- What channelisation code(s) are used for that transmission. The channelisation codes from different cells are not required to be the same as they are under different scrambling codes.
- The relative timing information, which needs to be made available at the new cell is indicated in Figure 5-1 (shows the case where the two involved cells are managed by different Node-Bs).

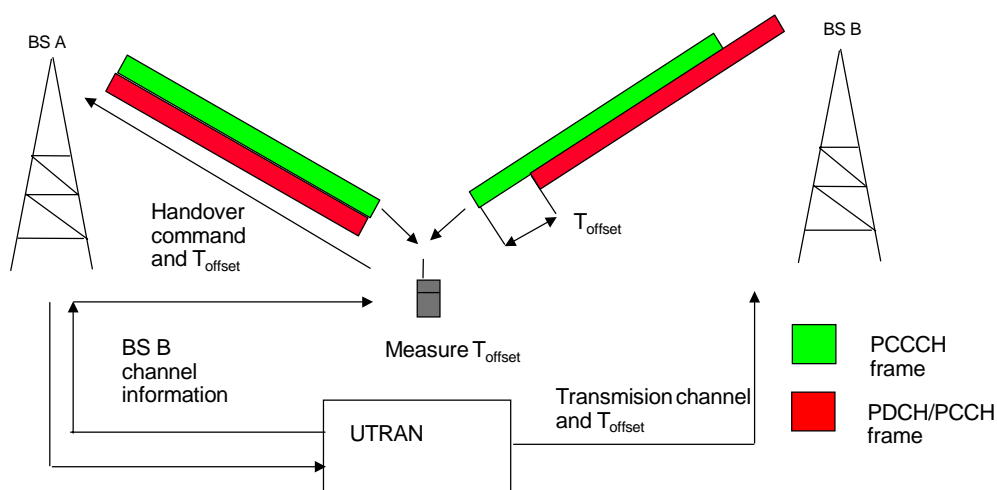

Figure 5-2: Making transmissions capable to be combined in the Rake receiver from timing point of view

At the start of diversity handover, the reverse link dedicated physical channel transmitted by the UE, and the forward link dedicated physical channel transmitted by the diversity handover source Node-B will have their radio frame

number and scrambling code phase counted up continuously as usual, and they will not change at all. Naturally, the continuity of the user information mounted on them will also be guaranteed, and will not cause any interruption.

5.1.5 Inter Radio Access Technology Handover

5.1.5.1 Handover 3G to 2G

The handover from UTRA to GSM offering world-wide coverage already today has been one of the main design criteria taken into account in the UTRA frame timing definition.

The handover from UTRA/FDD to GSM can be implemented without simultaneous use of two receiver chains. Although the frame length is different from GSM frame length, the GSM traffic channel and UTRA FDD channels use similar multi-frame structure.

A UE can do the measurements by using idle periods in the downlink transmission, where such idle periods are created by using the downlink Compressed Mode as defined in WG1 Specification. The Compressed Mode is under the control of the UTRAN, and the UTRAN should communicate to the UE which frame is slotted.

Alternatively independent measurements not relying on the Compressed Mode, but using a dual receiver approach can be performed, where the GSM receiver branch can operate independently of the UTRA FDD receiver branch.

The Handover from UTRA/TDD to GSM can be implemented without simultaneous use of two receiver chains. Although the frame length is different from GSM frame length, the GSM traffic channel and UTRA TDD channels rely on similar multi-frame structure.

A UE can do the measurements either by efficiently using idle slots or by getting assigned free continuous periods in the downlink part obtained by reducing the spreading factor and compressing in time TS occupation in a form similar to the FDD Compressed Mode. The low-cost constraint excludes the dual receiver approach.

For smooth inter-operation, inter-system information exchanges are needed in order to allow the UTRAN to notify the UE of the existing GSM frequencies in the area and vice versa. Further more integrated operation is needed for the actual handover where the current service is maintained, taking naturally into account the lower data rate capabilities in GSM when compared to UMTS maximum data rates reaching all the way to 2 Mbits/s.

5.1.5.2 Handover 2G to 3G

In the following clauses, first the general concept and requirements are introduced. Next the typical flow of information is described.

5.1.5.2.1 Introduction

The description provided in the following mainly deals with the use of predefined radio configuration during handover from 2G to 3G. However, the description of the handover information flows also includes details of other RRC information transferred during handover e.g. UE radio capability and security information.

5.1.5.2.2 Predefined radio configuration information

In order to reduce the size of certain size critical messages in UMTS, a network may download/ pre-define one or more radio configurations in a mobile. A predefined radio configuration mainly consists of radio bearer- and transport channel parameters. A network knowing that the UE has suitable predefined configurations stored can then refer to the stored configuration requiring only additional parameters to be transferred.

Predefined configurations may be applied when performing handover from another RAT to UTRAN. In the case of handover from GSM to UTRAN, the performance of handover to UTRAN is improved when it is possible to transfer the handover to UTRAN command within a non-segmented GSM air interface message.

Furthermore, it is important to note that it is a network option whether or not to use pre-configuration; the handover to UTRAN procedures also support transfer of a handover to UTRAN command including all parameters.

NOTE: In case segmentation is used, subsequent segments can only be transferred after acknowledgement of earlier transmitted segments. In case of handover however, the quality of the UL may be quite poor resulting in a failure to transfer acknowledgements. This implies that it may be impossible to quickly transfer a segmented handover message. Segmentation over more than two GSM air interface messages will have a significantly detrimental, and unacceptable, impact on handover performance.

The UE shall be able to store upto 16 different predefined configurations, each of which is identified with a separate pre-configuration identity. The UE need not defer accessing the network until it has obtained all predefined configurations. The network may use different configurations for different services e.g. speech, circuit switched data. Moreover, different configurations may be needed because different UTRAN implementations may require service configurations to be customised e.g. different for micro and macro cells.

The predefined configurations stored within the UE are valid within the scope of a PLMN; the UE shall consider these configurations to be invalid upon PLMN re-selection. Furthermore, a value tag is associated with each individual pre-defined configuration. This value tag, that can have 16 values, is used by the UE and the network to ensure the stored pre-defined configuration(s) is the latest/required version.

The current facilities in 25.331 have focused on the use of predefined configurations during handover from GSM to UTRAN. The same principles may also be applied for the handover procedures used within UTRAN e.g. handover including SRNC relocation. Use of predefined configurations in these cases may require extension of the currently defined RRC procedures.

5.1.5.2.3 Security and UE capability information

The security requirements concerning handover to UTRAN are specified in [14].

The initialisation parameters for ciphering are required to be transferred to the target RNC prior to the actual handover to UTRAN to ensure the immediate start of ciphering. For UEs involved in CS & PS domain services, R99 specifications support handover for the CS domain services while the PS domain services are re-established later. Consequently, in R99 only the START for the CS domain service needs to be transferred prior to handover. The START for the PS domain may be transferred at the end of the handover procedure, within the HANDOVER TO UTRAN COMPLETE message.

It should be noted that inter RAT handover normally involves a change of ciphering algorithm, in which case the new algorithm is included within the HANDOVER TO UTRAN COMMAND message.

Activation of integrity protection requires additional information transfer e.g. FRESH. Since the size of the HANDOVER TO UTRAN COMMAND message is critical, the required integrity protection information can not be included in this message. Instead, integrity protection is started immediately after handover by means of the security mode control procedure. Therefore, the HANDOVER TO UTRAN COMMAND and the HANDOVER TO UTRAN COMPLETE messages are not integrity protected.

5.1.5.2.4 UE capability information

When selecting the RRC radio configuration parameters to be included in the HANDOVER TO UTRAN COMMAND message, UTRAN should take into account the capabilities of the UE. Therefore, the UE radio capability information should be transferred to the target RNC prior to handover to UTRAN

5.1.5.2.5 Handover to UTRAN information flows, typical example

The handover to UTRAN procedure may include several subsequent information flows. The example described in this section is representative of a typical sequence of information flows. It should be noted that some procedures may actually be performed in parallel e.g. configuration of UTRA measurements and downloading of pre-defined configurations.

NOTE: Since work is ongoing in this area, the names of the information flows provided in the following diagrams may not reflect the latest status of standards/ CRs.

The description includes the different network nodes and interfaces involved in the handover to UTRAN procedure.

Flow 1: Downloading of predefined configuration information within UTRA

If the mobile uses UTRA prior to entering another RAT, it may download predefined configuration information as shown in the following diagram. UTRAN broadcasts predefined configuration information within the system information. The UE should read and store all the configurations broadcast by UTRAN. The configurations should be used when re- entering UTRAN.

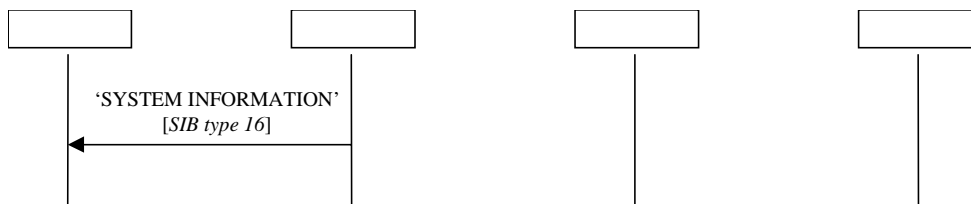

Flow 2: UE capability, security and pre- defined configuration information exchange

In order to prepare for handover to UTRAN, the BSS may retrieve UE capability, security and pre- defined configuration status information by means of the sequence shown below. This procedure may not only be invoked upon initial entry of a mobile supporting UTRA within GSM, but also when the mobile continues roaming within the GSM network. It should be noted that, the mobile could also send the information automatically by means of the early classmark change procedure.

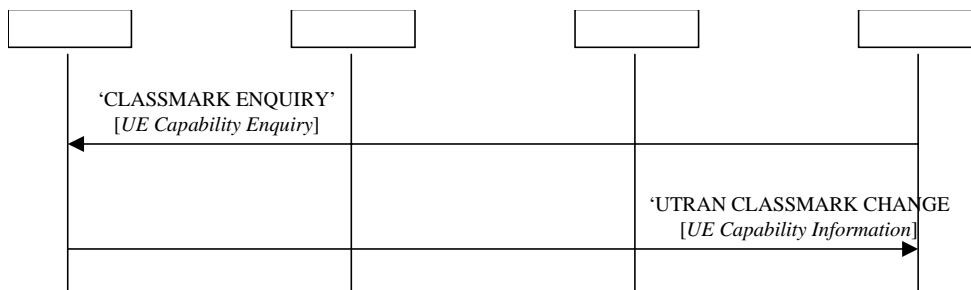

Furthermore, pre- defined configuration status information may be transferred to the BSS during handover from UTRAN.

The BSS has to store the received information until the handover to UTRAN is invoked.

NOTE 1: During the handover procedure, the stored UE capability and security information is sent to the target RNC.

NOTE 2: Depending on the received predefined configuration status information, the BSS may need to invoke the procedure for downloading predefined configurations, as described in flow 4

Flow 3: Configuration of UTRA measurements

The BSS configures the UTRA measurements to be performed by the mobile, including the concerned thresholds and the reporting parameters, by means of the following information flow.

NOTE: The BSS may possibly decide the measurement configuration to be used based upon previously received UE capability information (e.g. supported modes & bands)

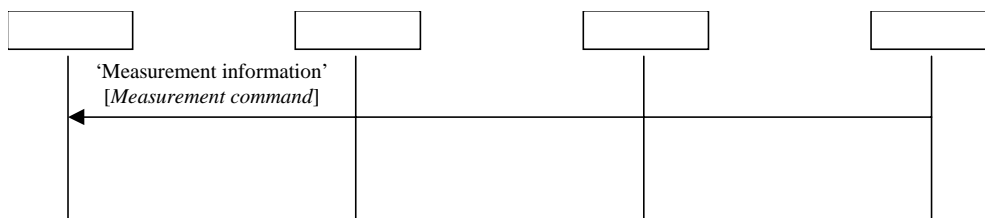

NOTE: The network may also provide information about neighbouring UTRAN cells within the CHANNEL RELEASE message.

Flow 4: Downloading of pre- defined radio bearer configurations within GSM

The pre-defined configuration status information (indicating which configurations are stored, as well as their value tags) is included in the UTRAN CLASSMARK CHANGE message. This information may indicate that the UE does not have the required predefined configuration stored, in which case the BSS should initiate the transfer of these configurations by means of the information flow shown below.

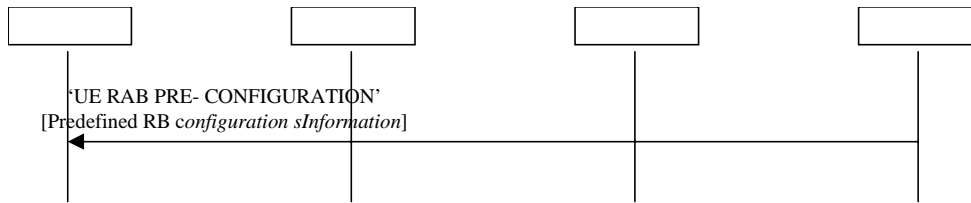

Flow 5: Handover

When the BSS decides that handover to UTRAN should be performed, triggered by the reception of a measurement report, it initiates the handover procedure. Next, the CN requests resources by sending a Relocation request to the target RNC. This message should include the UE capability and security information previously obtained by the BSS. The pre- defined configuration status information should be included in the Relocation request also. The main reason for this is that when selecting the predefined configuration to be indicated within the handover to UTRAN command message, the target RNC should know if the UE has downloaded all predefined configurations or only a subset.

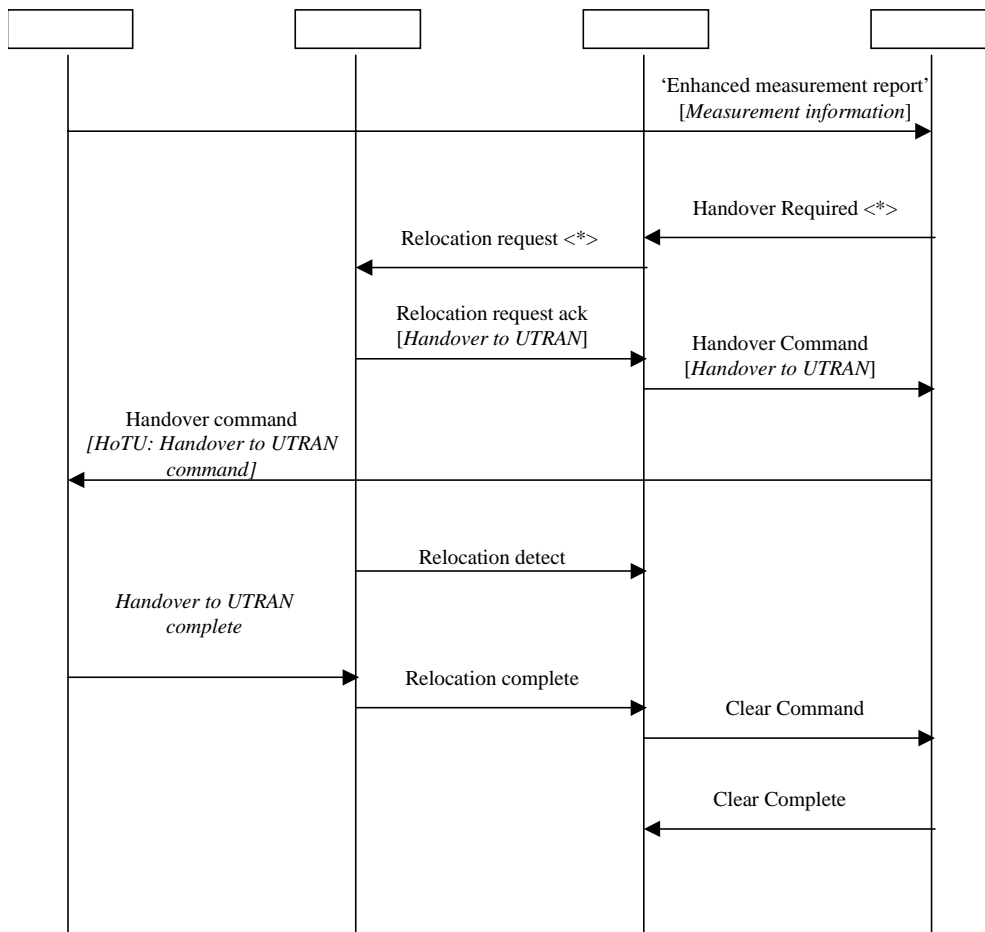

The relocation request includes an indication of the service type for which the handover is requested. This information is used by the target RNC to select the predefined configuration to be used by the UE, which is included within the handover to UTRAN command.

5.1.6 Measurements for Handover

5.1.6.1 Monitoring of FDD cells on the same frequency

During the measurement process of cells on the same frequencies, the UE shall find the necessary synchronisation to the cells to measure using the primary and secondary synchronisation channels and also the knowledge of the possible scrambling codes in use by the neighbouring cells.

5.1.6.2 Monitoring cells on different frequencies

5.1.6.2.1 Monitoring of FDD cells on a different frequency

Upper layers may ask FDD UE to perform preparation of inter-frequency handover to FDD. In such case, the UTRAN signals to the UE the handover monitoring set, and if needed, the compressed mode parameters used to make the needed measurements. Setting of the compressed mode parameters defined in [3] for the preparation of handover from UTRA FDD to UTRA FDD is indicated in the following section. The compressed mode for IFHO preparation from UTRA-FDD to UTRA-FDD has two different modes. One is "selection-mode". The UE must identify the cell during this mode. The other is "reselection-mode". The UE measures signal strength by the scrambling code already known. Selection mode / reselection mode parameter sets are described in section 5.6.1.2.1.1/5.6.1.2.1.2 respectively.

Measurements to be performed by the physical layer are defined in [3].

5.1.6.2.1.1 Setting of the compressed mode parameters for selection mode

During the transmission gaps, the UE shall perform measurements so as to be able to report to the UTRAN the frame timing, the scrambling code and the E_c/I_o of Primary CCPCH of up FDD cells in the handover monitoring set.

When compressed mode is used for cell acquisition at each target FDD frequency, the parameters of compressed mode pattern are fixed to be:

	TGL	TGD	TGP1	TGP2	PD
Pattern1	7	24/15	4	20	M
Pattern2	7	24/15	4	140	M
Pattern3	7	2	4	Not Used	M
Pattern4	7	2	4	20	M
Pattern5	7	2	4	140	M
Pattern6	14	3	6	18	M
Pattern7	14	3	6	138	M

NOTE: The frequency switching time required for UE is assumed to be 666us (equal to the slot duration) which includes implementation margin. This assumption means UE will consume 1slot of TGL for frequency switching (go and return) time.

5.1.6.2.1.2 Setting of the compressed mode parameters for reselection mode

This parameter sets are used for UE which already know the downlink scrambling code. UTRAN indicate which pattern will be used by UE. According to the result during reselection mode, If needed, UTRAN will indicate the transition back to the selection mode.

	TGL	TGD	TGP1	TGP2	PD
Pattern8	7	0	72	Not Used	M
Pattern9	7	0	144	Not Used	M

5.1.6.2.2 Monitoring of TDD cells

Upper layers may ask dual mode FDD/TDD UE to perform preparation of inter-frequency handover to TDD. In such case, the UTRAN signals to the UE the handover monitoring set, and if needed, the compressed mode parameters used to make the needed measurements. Setting of the compressed mode parameters defined in [3] for the preparation of handover from UTRA FDD to UTRA TDD is indicated in the following section. Measurements to be performed by the physical layer are defined in section 5.

5.1.6.2.2.1 Setting of the compressed mode parameters

When compressed mode is used for cell acquisition at each target TDD frequency, the parameters of compressed mode pattern are fixed to be:

TGL	TGD	TGP	PD

NOTE: settings for cell acquisition are FFS.

5.1.6.2.2.2 Setting of compressed mode parameters with prior timing information between FDD serving cell and TDD target cells

When UTRAN or UE have this prior timing information, the compressed mode shall be scheduled by upper layers with the intention that SCH on the specific TDD base station can be decoded at the UE during the transmission gap.

TGL	SFN	SN
4	(calculated by UTRAN)	(calculated by UTRAN)

5.1.6.2.3 Monitoring of GSM cells

Upper layers may ask dual mode FDD/GSM UE to perform preparation of inter-frequency handover to GSM. In such case, the UTRAN signals to the UE the handover monitoring set, and, if needed, the compressed mode parameters used to make the needed measurements.

The involved measurements are GSM BCCH power measurements (Section 5.1.6.2.3.1), initial GSM SCH or FCCH acquisition (Section 5.1.6.2.3.2), acquisition/tracking of GSM SCH or FCCH when timing information between UTRA serving cells and the target GSM cell is available (Section 5.1.6.2.3.3), and BSIC reconfirmation (Section 5.1.6.2.3.4).

5.1.6.2.3.1 Setting of compressed mode parameters for Power measurements

When compressed mode is used for GSM BCCH power measurements, the parameters of compressed mode pattern are fixed to be:

Pattern No.	TGL	TGD	TGP	PD
1	3	0	8	128

Pattern 1 allows measuring all the adjacent cell signal levels even with the maximum of 32 frequencies, if two measurements are done during each transmission gap. The pattern can be repeated by sending the measurement request again, if more measurement data is desired.

In order to fulfil the expected GSM power measurements requirement, the UE can get effective measurements samples during a time window of length T_{meas} , equal to the transmission gap length reduced by an implementation margin of $[2 \cdot 500 \mu s + 200 \mu s]$, which includes the maximum allowed delay for a UE's synthesiser to switch from one FDD frequency to one GSM frequency and switch back to FDD frequency, plus some additional implementation margin.

5.1.6.2.3.2 Setting of compressed mode parameters for first SCH decoding without prior knowledge of timing information

The setting of the compressed mode parameters is described in this section when used for first SCH decoding of one cell when there is no knowledge about the relative timing between the current FDD cells and the neighbouring GSM cell.

On upper layers command, UE shall pre-synchronise to the each of GSM cells in the handover monitoring set and decode their BSIC [GSM 05-series].

When compressed mode is used to perform initial FCCH/SCH acquisition, the compressed mode pattern belongs to the list of patterns in table.

In order to fulfil the expected GSM SCH speed requirement, the UE can get effective measurements samples during a time window of length T_{meas} , equal to the transmission gap length reduced by an implementation margin of $[2 \cdot 500 \mu s]$

+ 200 µs], that includes the maximum allowed delay for a UE's synthesiser to switch from one FDD frequency to one GSM frequency and switch back to FDD frequency, plus some additional implementation margin.

	TGL	TGD	TGP	PD parallel search / serial search
Pattern 1	7	0	2	40/64
Pattern 2	7	0	3	39/63
Pattern 3	7	2	9	63/252
Pattern 4	7	3	12	99/123
Pattern 5	14	0	2	12/26
Pattern 6	14	2	6	24/48
Pattern 7	14	2	8	34/58
Pattern 8	14	2	12	60/84
Pattern 9	10	12	48	108/828
Pattern 10	10	0	48	240/1440

The pattern duration for the parallel search (time until a GSM FCCH or SCH burst is found) and for the serial search (time until a FCCH burst is found) is given.

The patterns 5...8 should mainly be used in such cases where the present signal level suddenly drops and very little time to execute the handover is available. Patterns 1...4 are significantly more optimal from the point of view of the transmission power control than the other ones, while patterns 5...8 consume less slots for the measurements on the average.

Patterns 1...4 may use any pattern described in [2]. Patterns 5...10 must use the double frame method.

The patterns 9 and 10 are optimised for least consumption of slots for the measurements on the average using the parallel search. The patterns 9 and 10 achieve about the same or half the speed of the synchronisation to GSM from GSM.

Each pattern corresponds to a different compromise between speed of GSM SCH search and rate of use of compressed frames. On upper layers command, the repetition of the selected pattern can be stopped and/or replaced by one of the other listed patterns. Upper layers may also decide to alternate the use of different patterns periods.

Depending on the UE's capabilities, the search procedure may be sequential (tracking of FCCH burst before decoding of the first SCH) or parallel (parallel tracking of FCCH and SCH bursts). The latter solution achieves SCH decoding faster than the first one, thus decreasing the needed number of repeated patterns.

Once the UE has completed the search it signals the UTRAN with FCCH-found or SCH-found, both with the timing of the associated SCH burst, or with FCCH/SCH-not-found [GSM 05-series].

In case of FCCH-found, the UTRAN can continue the current pattern until also SCH is found or stop it and schedule a single, properly aligned gap for SCH search as described in 5.1.6.2.3.3.

Whenever UE receives a new neighbour cell with a sufficiently high power level [GSM 05-series], it shall perform a new SCH search procedure.

When a compressed mode pattern is available, then it is up to the UE to trigger this search procedure with the available transmission gaps. In this case, no specific signalling is needed between the UE and the UTRAN.

When a compressed mode pattern is not available, the UE shall initiate the search procedure by sending a "request new cell search" message to the UTRAN. Based on the UE's capabilities for serial or parallel search as described above, the UTRAN then determines a suitable compressed mode pattern and signals this to the UE. The upper layers can delay the onset of this pattern depending on the timing priority the Network Operator has set for new BSIC identification.

5.1.6.2.3.3 Setting of compressed mode parameters for first SCH decoding with prior timing information between UTRAN serving cells and GSM target cells

UTRAN or UE may have some prior knowledge of timing difference between some FDD cells in UE's active set and some GSM cells in the handover monitoring set. When this information is acquired by the UE (e.g. after initial FCCH/SCH detection) and on upper layers command, the UE shall report it to the upper layers for verification of UTRAN's information, and feedback of this information from UTRAN to the other UE.

When UTRAN or UE have this prior timing information, the compressed mode shall be scheduled by upper layers with the intention that SCH (or FCCH if needed) on a specific GSM band can be decoded at the UE during the transmission gap.

The transmission gap parameters used for GSM FCCH/SCH tracking with prior timing information are:

TGL	SFN	SN
4	(calculated by UTRAN)	(calculated by UTRAN)

In addition to normal compressed mode parameters, UTRAN signals the following information to the UE:

- The GSM carrier for which the particular compressed frame is intended (BS ID, carrier no, etc.)

Once the UE has completed the search, it signals the UTRAN with the timing of the associated SCH burst or with SCH-not-found.

5.1.6.2.3.4 Setting of compressed mode parameters for SCH decoding for BSIC reconfirmation and procedure at the UE

In this paragraph it is assumed that the UE has successfully decoded one SCH burst of a given neighbouring GSM cell during the call.

When a compressed mode pattern is available, then it is up to the UE to trigger and perform the BSIC reconfirmation procedure with the available transmission gaps. In this case, no specific signalling is needed between the UE and the UTRAN for BSIC reconfirmation procedure.

When no compressed mode pattern is available then it is up to the UE to trigger and perform the BSIC reconfirmation procedure. In that case, UE indicates to the upper layers the schedule of the SCH burst of that cell, and the size of the necessary transmission gap necessary to capture one SCH burst. The Network Operator decides the target time for BSIC reconfirmation and the upper layers uses this and the schedule indicated by the UE to determine the appropriate compressed mode parameters.

The compressed mode parameters shall be one of those described in [3].

5.1.6.2.3.5 Parameterisation of the compressed mode for handover preparation to GSM

Whereas section 5.1.6.2.3.2 described the compressed mode parameterisation for the initial synchronisation tracking or reconfirmation for one cell and the compressed mode parameters for power measurement for one of multiple cells, there is a need to define the global compressed mode parameters when considering the monitoring of all GSM cells.

6 Admission Control

6.1 Introduction

In CDMA networks the 'soft capacity' concept applies: each new call increases the interference level of all other ongoing calls, affecting their quality. Therefore it is very important to control the access to the network in a suitable way (Call Admission Control - CAC).

6.2 Examples of CAC strategies

Principle 1: Admission Control is performed according to the type of required QoS.

"Type of service" is to be understood as an implementation specific category derived from standardised QoS parameters.

The following table illustrates this concept:

Table 6-1: (*) Premium service: Low delay, high priority. () Assured Service: A minimum rate below the mean rate is guaranteed, service may use more bandwidth if available, medium priority. (***) Best Effort: No guaranteed QoS, low priority**

Service	Domain	Transport Channel	Type of service	CAC performed
Voice	CS	DCH	Premium (*)	YES
	IP	DCH	Premium (*)	YES
Web	IP	DSCH	Assured Service (**)	YES
	IP	DSCH	Best Effort (***)	NO

Other mappings are possible like for instance:

PSTN domain: Premium service, IP domain: Best Effort.

Principle 2: Admission Control is performed according to the current system load and the required service.

The call should be blocked if none of the suitable cells can efficiently provide the service required by the UE at call set up (i.e., if, considering the current load of the suitable cells, the required service is likely to increase the interference level to an unacceptable value). This would ensure that the UE avoids wasting power affecting the quality of other communications.

In this case, the network can initiate a re-negotiation of resources of the on-going calls in order to reduce the traffic load.

Assumption: Admission Control is performed by CRNC under request from SRNC.

6.3 Scenarios

6.3.1 CAC performed in SRNC

Figure 6-1 is to be taken as an example. It describes the general scheme that involves Admission Control when no Iur is used and the CRNC takes the role of SRNC.

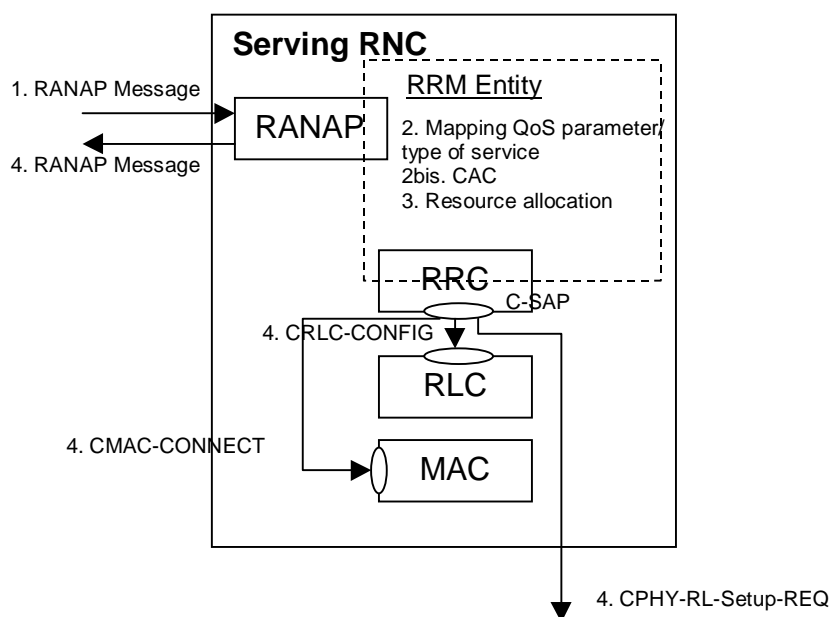

Figure 6-1: This model shows how standardised RANAP and RRC layers are involved in the CAC process

1. CN requests SRNC for establishing a RAB indicating QoS parameters.

2. According to QoS parameters the requested service is assigned a type of service. CAC is performed according to the type of service.
3. Resources are allocated according to the result of CAC.
4. Acknowledgement is sent back to CN according to the result of CAC. Sub_layers are configured accordingly.

Steps 2 to 4 may also be triggered by SRNC for reconfiguration purpose within the SRNC (handovers intra-RNC, channels reconfigurations, location updates).

6.3.2 CAC performed in DRNC

If a radio link is to be set up in a node-B controlled by another RNC than the SRNC a request to establish the radio link is sent from the SRNC to the DRNC. CAC is always performed in the CRNC, and if Iur is to be used as in this example, CAC is performed within the DRNC.

6.3.2.1 Case of DCH

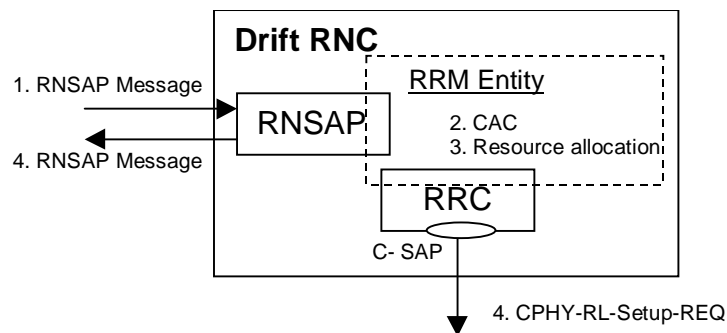

Figure 6-2: This model shows how standardised RNSAP and RRC layers are involved in the CAC process

1. SRNC requests DRNC for establishing a Radio Link, indicating DCH characteristics. These implicitly contain all QoS requirements and are enough as inputs to the CAC algorithm.
2. CAC is performed according to DCH characteristics.
3. Resources are allocated according to the result of CAC.
4. Acknowledgement is sent back to the SRNC according to the result of CAC.

6.3.2.2 Case of Common Transport Channels

When transmitting on Common Transport Channels a UE may camp on a new cell managed by a new RNC. SRNC is notified by UE through RRC messages that connection will be set up through a new DRNC. Subsequently SRNC initiates connection through new DRNC.

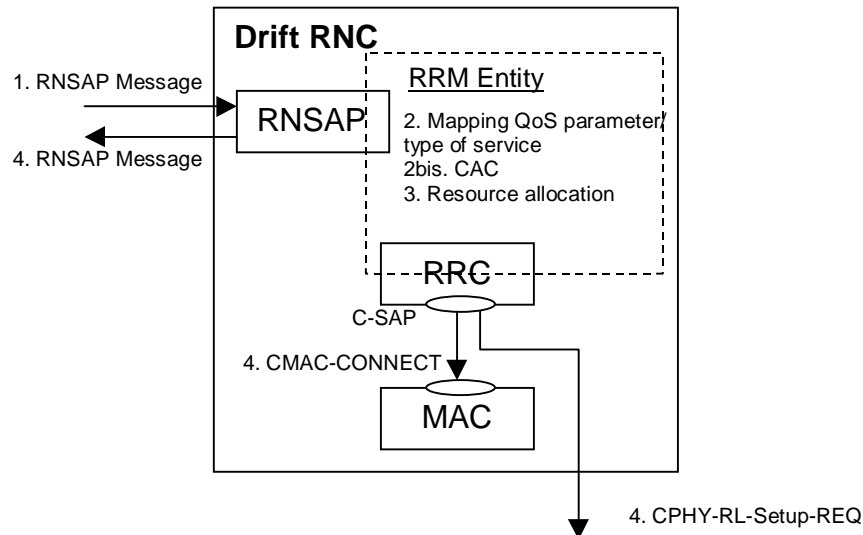

Figure 6-3: This model shows how standardised RNSAP and RRC layers are involved in the CAC process

1. SRNC requests DRNC for establishing a Radio Link. A RNSAP message contains the QoS parameters and the type of Common Transport Channel to be used.
2. According to QoS parameters the requested service is assigned a type of service. CAC is performed according to the type of service and to the type of Common Transport Channel requested by SRNC.
3. Resources are allocated according to the result of CAC.
4. Acknowledgement is sent back to the SRNC according to the result of CAC. L1 and MAC are configured accordingly by RRC layer.

7 Radio Bearer Control

7.1 Usage of Radio Bearer Control procedures

Radio Bearer (RB) Control procedures are used to control the UE and system resources. This section explains how the system works with respect to these procedures and how e.g. traffic volume measurements could trigger these procedures.

7.1.1 Examples of Radio Bearer Setup

In order to set up a new RB, a RRC connection must have been established, and some NAS negotiation has been performed. The RB Setup message comes from UTRAN and depending on the requirement of the service a common or a dedicated transport channel could be used. In the example below the UE is using a common transport channel for the RRC connection and stays on the common transport channel after the RB setup.

However, transport channel parameters such as transport formats and transport format combinations are configured not only for the used common transport channel, but also for dedicated transport channel for future use.

All physical parameters are the same before and after the RB setup in this example.

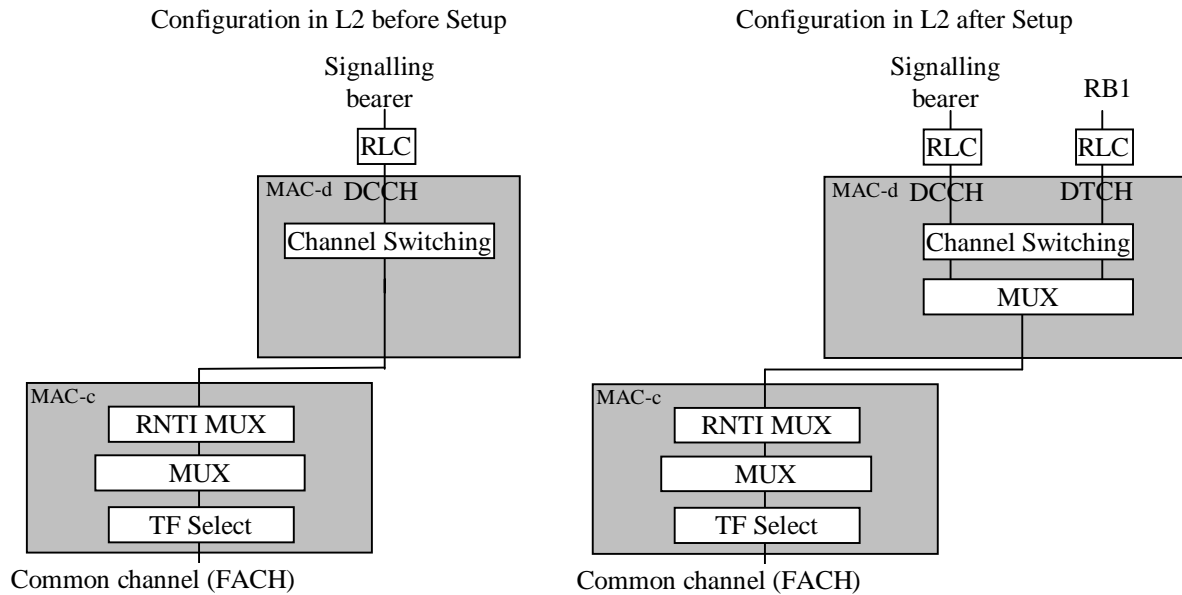

Figure 7-1: Configuration of L2 in the UTRAN DL before and after the RB setup

Detailed examples of messages exchange and parameters used is reported in Appendix B, Section. B.1.

7.1.2 Examples of Physical Channel Reconfiguration

This RRC procedure is used to reconfigure the Physical channel and can by that also trigger Transport channel type switching.

Below several examples of Physical Channel reconfigurations are shown, triggered by different amount of UL or DL data.

7.1.2.1 Increased UL data, with switch from RACH/FACH to DCH/DCH

A UE that is in the RACH/FACH substate can transmit a small amount of user data using the common transport channels. For larger amounts it is more appropriate to use a dedicated transport channel. Since each UE doesn't know the total load situation in the system UTRAN decides if a UE should use common transport channels or a dedicated transport channel.

The monitoring of UL capacity need is handled by a UTRAN configured measurement in the UE. When the amount of data in the RLC buffer to be transmitted in the UL increases over a certain threshold the UE sends a measurement report to UTRAN. This threshold to trigger the report is normally given in System Information, but UTRAN can also control the threshold in a UE dedicated Measurement Control message.

Since, UTRAN has the current status of the total UL need it can decide which UEs that should be switched to a dedicated transport channel. If UTRAN has pre-configured the transport formats and transport format combinations to be used on the dedicated transport channel for the UE, a Physical channel reconfiguration procedure could be used to assign dedicated physical resources.

The spreading factor for the physical channels assigned then give, which transport format combinations that are allowed to use.

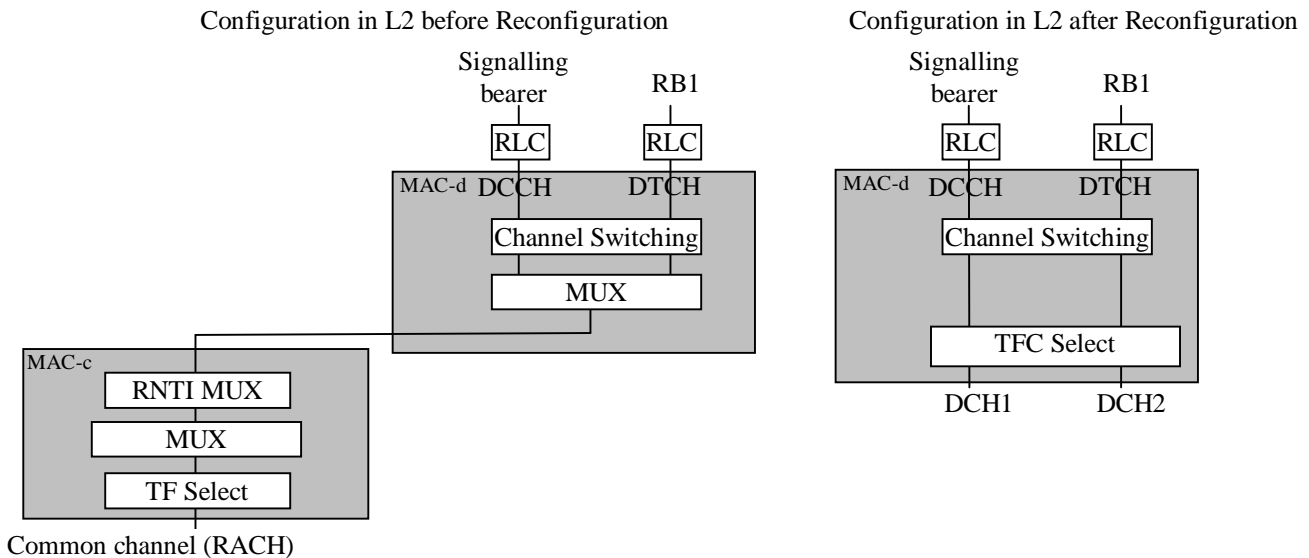

Figure 7-2: Configuration in the UTRAN UL before and after the Physical channel reconfiguration

Detailed examples of messages exchange and parameters used is reported in Appendix B, Section. B.2.1.

7.1.2.2 Increased DL data, no Transport channel type switching

If the RLC buffer increases above a certain threshold in the network the UTRAN can do a physical channel reconfiguration. Here the UE uses a dedicated transport channel, and this procedure is used to decrease the spreading factor of the physical dedicated channel. This way this variable bitrate service increases the throughput on the downlink.

A variable bitrate service that has large traffic variations should have transport formats and transport format combinations defined for lower spreading factors than currently used on the physical channel. Then after the physical channel reconfiguration that lowers the spreading factors these transport formats and transport format combinations could be used to increase the throughput for this user.

However, if the transport formats and transport format combinations have not been previously defined to support a lower spreading factor, a Transport channel reconfiguration must be used instead in order to get any increased throughput.

Only downlink physical parameters are changed here since the uplink in this scenario doesn't need to increase its capacity.

Detailed examples of messages exchange and parameters used is reported in Appendix B, Section. B.2.2.

7.1.2.3 Decrease DL data, no Transport channel type switching

Since downlink channelisation codes are a scarce resource a UE with a too high, allocated gross bit rate (low spreading factor) must be reconfigured and use a more appropriate channelisation code (with higher spreading factor). This could be triggered by a threshold for the RLC buffer content and some inactivity timer, i.e. that the buffer content stays a certain time below this threshold.

After the physical channel has been reconfigured, some of the transport formats and transport format combinations that require a low SF can not be used. However, these are stored and could be used if the physical channel is reconfigured later to use a lower spreading factor.

Detailed examples of messages exchange and parameters used is reported in Appendix B, Section B.2.3.

7.1.2.4 Decreased UL data, with switch from DCH/DCH to RACH/FACH

In the network the UE traffic can be evaluated and the network can observe which transport format combinations that are used in the UL. The network could also simply look at how much data the UE transmits or use measurement reports.

If the UE is transmitting a low amount of data in the uplink and there is little traffic in the downlink, this could trigger a switch from a dedicated transport channel to a common transport channel. Depending on if the already defined RACH/FACH configuration is possible/preferred in the cell that the UE will be in after the switch, a Transport channel reconfiguration or a Physical channel reconfiguration procedure is used.

In the example below the UE has stayed in cells with a similar RACH and FACH configuration when using a dedicated transport channel. Therefore, the Physical channel reconfiguration procedure can be used. In 8.1.3.2 this is not the case and a Transport channel reconfiguration is used instead.

After the UE has performed the transport channel type switch to the RACH/FACH substate, all transport channel parameters such as transport formats for the dedicated transport channel are stored. The same configuration of the dedicated transport channels could then be reused if the UE switches back to the DCH/DCH substate.

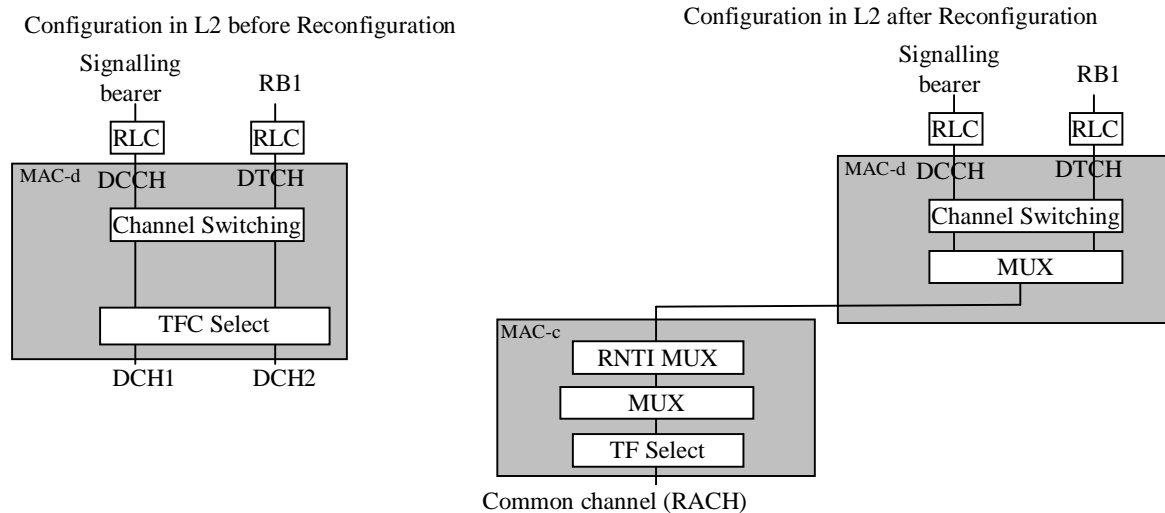

Figure 7-3: Configuration in the UTRAN UL before and after the Physical channel reconfiguration

Detailed examples of messages exchange and parameters used is reported in Appendix B, Section. B.2.4.

7.1.3 Examples of Transport Channel Reconfiguration

This RRC procedure is used to reconfigure the transport channel and the physical channels, and can by that also trigger Transport channel type switching.

Below, several examples of Transport channel reconfiguration are shown, triggered by different amount of UL or DL data.

7.1.3.1 Increased UL data, with no transport channel type switching

When a UE RLC buffer content increases above a certain threshold, a measurement report is sent to UTRAN. Depending on the overall load situation in the network the UTRAN could decide to increase the uplink capacity for a UE. Since every UE has its "own" code tree, there is no shortage of UL codes with a low spreading factor, and all UEs can have a low spreading factor code allocated.

Therefore, instead of channelisation code assignment as used in the DL, load control in the UL is handled by the allowed transport formats and transport format combinations for each UE. To increase the throughput for a UE in the uplink, UTRAN could send a Transport channel reconfiguration or a TFC Control message.

Here a Transport channel reconfiguration is used. Although, the TFC Control procedure is believed to require less signalling it can only restrict or remove restrictions of the assigned transport format combinations and that may not always be enough. If a reconfiguration of the actual transport formats or transport format combinations is required, the Transport channel reconfiguration procedure must be used instead.

In the example below, the UE is allowed to send more data in the UL when on dedicated transport channel, although the common transport channel configuration is still the same. To make use of the new transport format combinations the physical channel must also be reconfigured to allow a lower spreading factor.

Detailed examples of messages exchange and parameters used is reported in Appendix B, Section. B.3.1.

7.1.3.2 Decreased DL data, with switch from DCH/DCH to RACH/FACH

In the network the downlink traffic to a UE can be evaluated and the network can observe which transport format combinations that are used.

If a low amount of data is sent to the UE in the downlink and there is little traffic in the uplink, this could trigger a switch from a dedicated transport channel to a common transport channel. Depending on if the already defined RACH/FACH configuration is possible/preferred in the cell that the UE will be connected to after the switch, a Transport channel reconfiguration or a Physical channel reconfiguration procedure is used. In this example the UE has moved to cells with a different FACH or RACH configuration when using a dedicated transport channel, so a Transport channel reconfiguration procedure must be used.

When the UE do the switch from a dedicated transport to a common transport channel the RACH and FACH transport channels are reconfigured with new transport formats if the old configuration is not supported in the new cell. What physical common channel to be used is pointed out in the physical channel parameters.

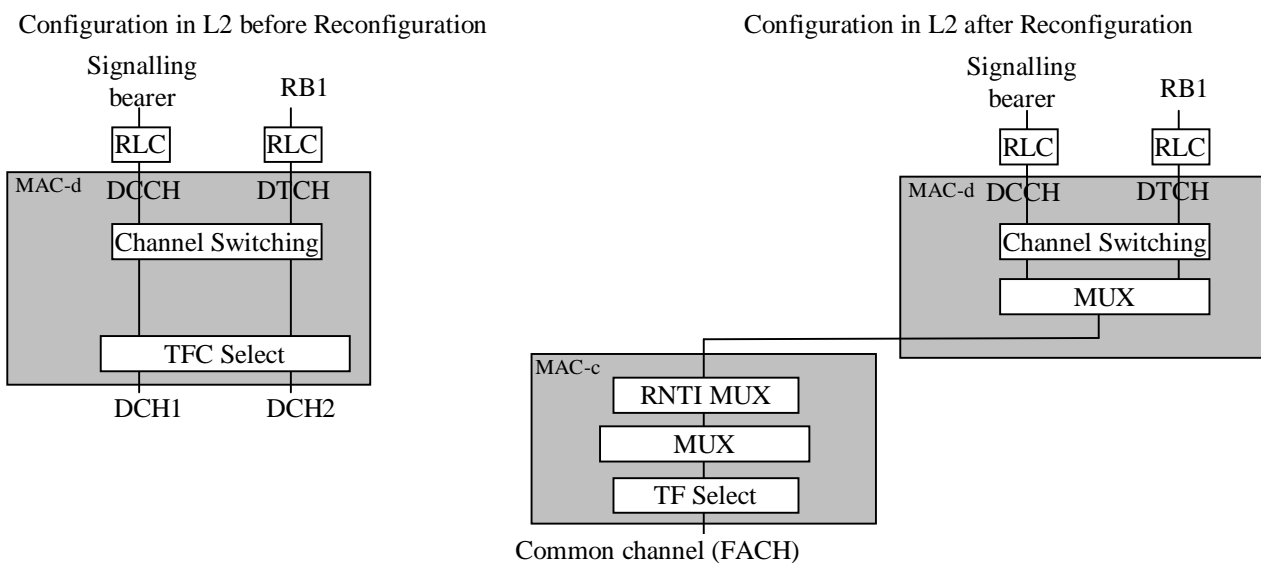

Figure 7-4: Configuration in the UTRAN DL before and after the Transport channel reconfiguration

Detailed examples of messages exchange and parameters used is reported in Appendix B, Section. B.3.2.

7.1.4 Examples of Radio Bearer Reconfiguration

A RB reconfiguration is here used to change how the MUX in MAC of logical channels belonging to different RBs is configured.

The RB Reconfiguration message includes parameters for the new multiplexing configuration in MAC, and a reconfiguration of the Transport channel that both RBs will use. The old obsolete transport channel is also removed (here DCH3 is removed). All other parameters associated with the RBs are unchanged.

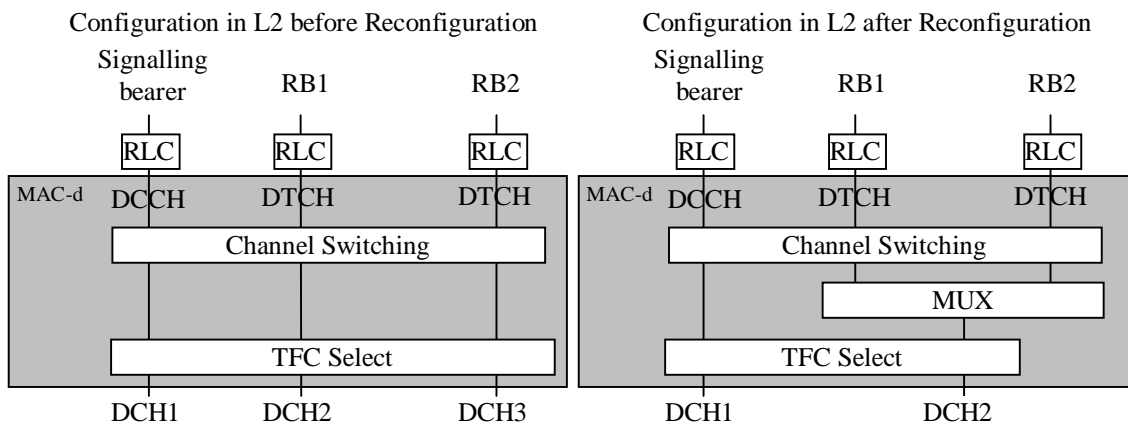

Figure 7-5: Configuration in the UTRAN DL before and after the RB reconfiguration

Detailed examples of messages exchange and parameters used is reported in Appendix B, Section. B.4.

8 Dynamic Resource Allocation

8.1 Code Allocation Strategies for FDD mode

8.1.1 Introduction

Code allocation deals with the problem how different codes are allocated to different connections. The channelisation codes used for spreading are Orthogonal Variable Spreading Factor (OVSF) codes that preserve the orthogonality between a user's physical channel. The OVFSF code is shown in the following figure:

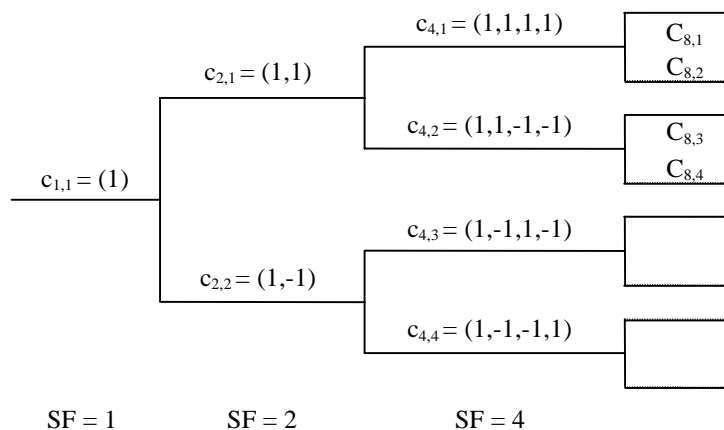

Figure 8-1: OVFSF Code Tree

Each level in the code tree is described as $C_{SF,code\ number}$, where the spreading factor (SF) is ranging from 4 to 512 for the chip rate of 3.84 Mcps. A code can be assigned to a UE if and only if no other code on the path from the specific code to the root of the tree or in the sub-tree below the specific code is assigned. For example, a random assignment of large-SF codes to low data rate channels may preclude a large number of small-SF codes. It inefficiently limits the number of remaining codes that could be used by other users. On the contrary, it will be advantageous to assign codes to low data rate users in such a way as to minimise the number of unavailable small-SF codes. Moreover, it is expected to be advantageous to assign users operative at a particular data rate to closely related codes so as to minimise the number of small-SF codes being marked as unavailable. A proper code allocation algorithm is used to find the "closely related code" to prevent the BS from running out of codes and to utilise the system resource effectively. The so-called "closely related code" would be obtained via a code allocation strategy according to the available codes of the BS and the capability of the UE.

8.1.2 Criteria for Code Allocation

OVSF codes are valuable resources in CDMA system. The objective of the code allocation is to support as many users as possible with less complexity.

In the application, different UEs may request for different types of services with different transmission rates. Each UE may have the capability to use more than one code to support different data rates. The following criteria can be envisaged:

1. **Utilisation.** The utilisation is defined as the ratio of assigned bandwidth and overall bandwidth. A code allocation scheme that preserves more small-SF codes has a higher chance to provide a higher utilisation. For example, $C_{4,1}$ and $(C_{8,1}, C_{8,3})$ are the available codes of a BS resulting from two different code allocation schemes. $C_{4,1}$ (which is equivalent to codes $C_{8,1}$ and $C_{8,2}$) can support a symbol rate up to 960 kbps. $(C_{8,1}, C_{8,3})$ can also support the same symbol rate as $C_{4,1}$ does. However, only $C_{4,1}$ can support the UE that requests for 960 kbps symbol rate using only one code (due to the capability of the handset). In this example, the former has more small-SF codes than the latter, thus, it will result in a better utilisation.
2. **Complexity.** The more codes are used, the complexity of the system will be increased. In some cases, there are more than one way to meet the first criterion mentioned above. For example, one UE can use either one code ($C_{4,1}$) or two codes ($C_{8,1}$ and $C_{8,2}$) as the channelisation codes. Under this situation, the code allocation scheme that requires the least codes should be chosen.

8.1.3 Example of code Allocation Strategies

An example of code allocation algorithm based on the two above criteria is presented in the following. In order to indicate the available OVSF codes of the system, an order pair C , called a code-word, is introduced. Let $C=(a_1, a_2, a_3, a_4, a_5, a_6, a_7)$ denote the available codes for SF=(4,8,16,32,64,128,256), respectively, where $a_1 \leq 4$, $a_2 \leq 8$, $a_3 \leq 16$, $a_4 \leq 32$, $a_5 \leq 64$, $a_6 \leq 128$, and $a_7 \leq 256$. The total data rate (*i.e.* it has been normalised by a data rate of an OVSF code with SF=256) supported by C is called the weight W and can be obtained by:

$$W(C) = a_1 \cdot 2^6 + a_2 \cdot 2^5 + a_3 \cdot 2^4 + a_4 \cdot 2^3 + a_5 \cdot 2^2 + a_6 \cdot 2^1 + a_7.$$

$S(n)$ is a set of code-words that can support a total data rate up to n and it can be obtained by:

$$S(n) = \{C | W(C) \leq n, \forall C\}.$$

The number of codes $N(C)$ required for transmitting a code-word C can be calculated by:

$$N(C) = a_1 + a_2 + a_3 + a_4 + a_5 + a_6 + a_7.$$

Consider a UE which requests for a data rate of n . Define $C_r=(a_1, a_2, a_3, a_4, a_5, a_6, a_7)$ and $C_l=(a_1, a_2, a_3, a_4, a_5, a_6, a_7)$ are the code-words of the system before and after code allocation, respectively. For $W(C_r)=m$, we can find that $W(C_l)=W(C_r)-n=m-n$.

For example, $m=13$ and $n=6$ $C_r=(0,0,0,0,2,1,3)$.

The possible candidates for the allocated codes is one of the element of set $S(6)$, where:

$$S(6) = \{(0,0,0,0,0,0,6), (0,0,0,0,0,1,4), (0,0,0,0,0,2,2), (0,0,0,0,1,0,2), (0,0,0,0,0,3,0), (0,0,0,0,1,1,0)\} \\ \equiv \{C1, C2, C3, C4, C5, C6\}.$$

Thus, the possible code-words of the system after allocating the codes to the UE can be obtained by

$$T(7) = \{C_r - C1, C_r - C2, C_r - C3, C_r - C4, C_r - C5, C_r - C6\} \\ = \{(0,0,0,0,1,1,1), (0,0,0,0,1,1,1), (0,0,0,0,1,1,1), (0,0,0,0,1,1,1), (0,0,0,0,1,0,3), (0,0,0,0,1,0,3)\}.$$

According to the first criterion, $(0,0,0,0,1,1,1)$ is the preferred code-word (denoted as C_{opt}) after the allocation and $C1$, $C2$, $C3$, and $C4$ are possible candidates for the allocated code-words. The number of codes required for these code-words are $N(C1)=6$, $N(C2)=5$, $N(C3)=4$, and $N(C4)=3$. According to the second criterion, $C4$ would be chosen because it uses the least codes.

In general, it is not feasible to examine all of the possible code-words from the set $S(n)$ as illustrated above, especially for a large value of n . It is also a time-consuming process to find $T(m-n)$ by subtraction of the code-words individually. Here, a fast code allocation algorithm can be used to find the preferred code-word C_{opt} , where:

$$C_{opt} = C_r - (C_r - (0,0,0,0,0,0,n)).$$

In the above example, $C_r = (0,0,0,0,2,1,3)$, $n=6$, and $C_r - (0,0,0,0,0,0,6) = (0,0,0,0,1,1,1)$. Therefore, $C_{opt} = (0,0,0,0,2,1,3) - (0,0,0,0,1,1,1) = (0,0,0,0,1,0,2) = C_4$.

In a particular implementation of the code allocation algorithm, the BS could maintain a list of available codes. When UE requests for channel codes, the number of codes of different SF required supporting the required data rate could be identified by the code allocation algorithm. Upon identification of codes of suitable SFs, the BS will assign the codes from the table.

In the real system, the MS can use only k codes for transmitting data. In some cases, the fast code allocation algorithm cannot be applied. Therefore, two situations may occur:

Situation I. $N(C_{opt}) \leq k$:

- The procedure described above can be used and the allocated code-word $C = C_{opt}$.

Situation II. $N(C_{opt}) > k$:

- In this situation, the fast code allocation algorithm may not be applied because the MS can not support as many codes as that determined by C_{opt} . In this case, the allocated code-word C is the one that $N(C)=k$. However, the new call requests will be blocked if the MS can not support the requested data rate with the given number of codes k .

8.1.4 PDSCH code management

In this section two typical examples are given of the way in which the UTRAN might configure usage of the DSCH.

Where the DSCH is supported the information provided on TFCI(field 2) has to enable the UE to look up both the TFC used on the DSCH CCTrCH as well as the PDSCH channelisation code. Hence this section also provides guidance on how to use the various options provided in the RRC protocol for signalling this mapping table.

PDSCH code management is simplified if a bearer is configured such that in any one TTI it is possible to select codes for transmission toward a single user from a wide range of the available set of PDSCH codes. However, since the length of the TFCI(field 2) is limited this can mean that the number of possible transport format combinations which can be used for this user at a given spreading factor is limited. In Table 8-1 an example of a possible mapping table is shown, where as discussed the bearer has been configured to give the UTRAN a high degree of flexibility in code assignment but with a restricted number of TFC options per spreading factor. In the example the TFCI (field 2) is assumed to be 5 bits long, the PDSCH code sub-tree is 5 spreading factors deep and the UTRAN allows only one possible TFC per spreading factor.

Table 8-1: Example of a table which the UE must build to map TFCI (field 2) to CTFC and PDSCH channelisation code

TFCI (field 2)	CTFC	PDSCH Channelisation code
0	α	SF=128, Code number = 0
1	α	SF=128, Code number = 1
2	α	SF=128, Code number = 2
3	α	SF=128, Code number = 3
:	:	:
15	α	SF=128, Code number = 15
16	β	SF=64, Code number = 0
17	β	
:	:	:
23	β	SF=64, Code number = 7
24	χ	SF=32, Code number = 0
:	:	:
27	χ	SF=32, Code number = 3
28	δ	SF=16, Code number = 0
29	δ	SF=16, Code number = 1
30	ϵ	SF=8, Code number = 0

In order to signal this mapping table it is possible to make use of 'for' loops in order to reduce the amount of signalling information which has to be transferred in order to describe the mapping, this would be done as follows:

for TFCI2 range 0 to 15:

Channelisation codes have SF=128, and the code numbers corresponding to the TFCI2 values range from 0 to 15.

for TFCI2 range 16 to 23:

Channelisation codes have SF=64, and the code numbers corresponding to the TFCI2 values range from 0 to 7.

:

:

for TFCI2 range 0 to 15:

CTFC = α

for TFCI2 range 16 to 23:

CTFC = β

:

:

This method for signalling the mapping table is possible by using the 'code range' CHOICE in the RRC 'PDSCH code mapping' IE and by using the 'TFCI range' CHOICE in the RRC 'Transport format combination set' IE.

It is also possible that under some circumstances an operator may prefer or need to configure the bearer such that there are only a restricted set of PDSCH codes which may be used for a certain UE but where a large number of possible transport format combinations must be supported on each code. This approach might be taken if for example a large number of services are being multiplexed toward the user. In this case, given the limited number of TFCI (field 2) bits the only option may be to restrict the range of PDSCH codes which can be assigned to the UE. An example of the mapping table for this case is shown in Table 2, the 5 bits of TFCI(field2) in this case being used to differentiate between different TFCs.

Table 8-2: Another example of the table which the UE must build to map TFCI to CTFC and channelisation code

TFCI (field 2)	CTFC	PDSCH Channelisation code
0	α	SF=32, Code number = 0
1	β	SF=32, Code number = 0
2	γ	SF=32, Code number = 0
3	δ	SF=32, Code number = 0
4	ϵ	SF=32, Code number = 0
5	ζ	SF=32, Code number = 0
:	:	:
31	η	SF=32, Code number = 0

In this case in order to signal the mapping between TFCI (field 2) and CTFC it is most efficient to use explicit signalling, i.e. to have the CTFC identified individually for each possible value of TFCI(field 2). With regards to identifying the mapping between TFCI(field 2) and the channelisation code, it is on this occasion most efficient to identify the range of TFCI(field2) values for which the PDSCH channelisation code should be applied. This method for signalling the mapping table is possible by using the 'TFCI range' CHOICE in the RRC 'PDSCH code mapping' IE and by using the 'Explicit' CHOICE in the RRC 'Transport format combination set' IE.

8.2 DCA (TDD)

8.2.1 Channel Allocation

For the UTRA-TDD mode a physical channel is characterised by a combination of its carrier frequency, time slot, and spreading code as explained in the chapter on the physical channel structure.

Channel allocation covers both:

- resource allocation to cells (slow DCA);
- resource allocation to bearer services (fast DCA).

8.2.1.1 Resource allocation to cells (slow DCA)

Channel allocation to cells follows the rules below:

- A reuse one cluster is used in the frequency domain. In terms of an interference-free DCA strategy a timeslot-to-cell assignment is performed, resulting in a time slot clustering. A reuse one cluster in frequency domain does not need frequency planning. If there is more than one carrier available for a single operator also other frequency reuse patterns >1 are possible.
- Any specific time slot within the TDD frame is available either for uplink or downlink transmission. UL/DL resources allocation is thus able to adapt itself to time varying asymmetric traffic.
- In order to accommodate the traffic load in the various cells the assignment of the timeslots (both UL and DL) to the cells is dynamically (on a coarse time scale) rearranged (slow DCA) taking into account that strongly interfering cells use different timeslots. Thus resources allocated to adjacent cells may also overlap depending on the interference situation.
- Due to idle periods between successive received and transmitted bursts, UEs can provide the network with interference measurements in time slots different from the one currently used. The availability of such information enables the operator to implement the DCA algorithm suited to the network.
- For instance, the prioritised assignment of time slots based on interference measurements results in a clustering in the time domain and in parallel takes into account the demands on locally different traffic loads within the network.

8.2.1.2 Resource allocation to bearer services (fast DCA)

Fast channel allocation refers to the allocation of one or multiple physical channels to any bearer service Resource units (RUs) are acquired (and released) according to a cell-related preference list derived from the slow DCA scheme.

1. The following principles hold for fast channel allocation: The basic RU used for channel allocation is one code / timeslot / (frequency).
2. Multirate services are achieved by pooling of resource units. This can be made both in the code domain (pooling of multiple codes within one timeslot = **multicode** operation) and time domain (pooling of multiple timeslots within one frame = **multislot** operation). Additionally, any combination of both is possible. Simulation results reported in Appendix A, recommend that the DCA prefers code pooling, over time slot pooling, for UDD packet data; the use of code pooling in fact results in lower number of unsatisfied users.
3. Since the maximal number of codes per time slot in UL/DL depends on several physical circumstances like, channel characteristics, environments, etc. (see description of physical layer) and whether additional techniques to further enhance capacity are applied (for example smart antennas), the DCA algorithm has to be independent of this number. Additionally, time-hopping can be used to average inter-cell interference in case of low-medium bit rate users.
4. Channel allocation differentiates between RT and NRT bearer services:
 - RT services: Channels remain allocated for the whole duration the bearer service is established. The allocated resources may change because of a channel reallocation procedure (e.g. VBR).
 - NRT services: Channels are allocated for the period of the transmission of a dedicated data packet only UDD channel allocation is performed using 'best effort strategy', i.e. resources available for NRT services are distributed to all admitted NRT services with pending transmission requests. The number of channels allocated for any NRT service is variable and depends at least on the number of current available resources and the number of NRT services attempting for packet transmission simultaneously. Additionally, prioritisation of admitted NRT services is possible.
5. Channel reallocation procedures (intra-cell handover) can be triggered for many reasons:
 - To cope with varying interference conditions.
 - In case of high rate RT services (i.e. services requiring multiple resource units) a 'channel reshuffling procedure' is required to prevent a fragmentation of the allocated codes over to many timeslots. This is achieved by freeing the least loaded timeslots (timeslots with minimum used codes) by performing a channel reallocation procedure.
 - When using smart antennas, channel reallocation is useful to keep spatially separated the different users in the same timeslot.

8.2.2 Measurements Reports from UE to the UTRAN

While in active mode the DCA needs measurements for the reshuffling procedure (intra-cell handover). The specification of the measurements to be performed is contained in Section 7.4 in [3]. In this section the relevant measurement reports are presented:

- Pathloss of a sub-set of cells (pathloss is quantified in N_{PL} [e.g. 128] intervals; [max. number of cells is 30]).
- Inter-cell interference measurements of all DL time slots requested by the UTRAN (interference is quantified in N_{ICI} [e.g. 32] intervals, due to asymmetry up to 14 time slots are possible).
- BER of serving link (quantified in N_{BER} [e.g. 16] intervals).
- Transmission power of the UE on serving link (separated in N_{TX} [e.g. 64] intervals).
- DTX flag link.

Further measurements and reports can be requested by the UTRAN.

The RLC informs the DCA about transmission errors. The interaction between DCA and RLC depends on the RLC operation mode.

9 Power Management

9.1 Variable Rate Transmission

9.1.1 Examples of Downlink Power Management

When an RB connection with variable rate transmission is established, the RRC considers the down-link traffic conditions, then assigns the TFCS to MAC and allowable transmission power to L1. The allowable transmission power can be determined according to the service requirements and the traffic conditions, and is updated for each user when the traffic conditions change. RRC also assigns a measurement to Node B that sets the allowable transmission power to the transmitted code power.

During a call, the physical layer averages the transmission power for that UE over one or several frames. If the averaged transmission power for the UE becomes higher than the allowable transmission power, that is, the channel conditions are bad, L1 indicates to MAC that the "Allowable transmission power has been reached". The MAC in response reduces the data rate within TFCS, and the power control procedure then reduces the total transmission power for that UE and excess interference to other UEs is avoided. The PDUs that can not be transmitted in a TTI shall be buffered according to the discard function set by RRC.

When channel conditions improve and the averaged transmission power falls [margin] dB below than the allowable transmission power the physical layer indicates to MAC that the "Average transmission power is below allowable transmission power by margin dB" (the values for [margin] are chosen to match the power requirements of different increments for the transport channels within the TFCS). If there is enough data to be sent the MAC in response increases the data rate by increasing the number of transport blocks delivered to L1 and the physical layer increases the total transmission power to the UE by the predefined amount. This allows data that was buffered during bad channel conditions to be delivered to the UE.

Simulation results on down-link variable rate packet transmission are provided in Appendix E.

9.1.2 Examples of Uplink Power Management

When an RB connection with variable rate transmission is established, the RRC assigns the TFCS and the allowable transmission power to the UE. . The maximum allowed UE transmitter power is defined in [25.331].

During a call, the physical layer averages the transmission power over one or several frames. If the UE output power measured over at least [t1] ms is [margin1] dB within the maximum, the UE shall adapt the transport format combination corresponding to the next lower bit-rate. The PDUs that can not be transmitted in a TTI shall be buffered according to the discard function set by RRC.

When channel conditions improve and the averaged transmission power falls [margin] dB below than the allowable transmission power (the values for [margin] are chosen to match the power requirements of different increments in the number of transport channels within the TFCS) and there is enough data to be sent the UE shall continuously estimate whether the output power needed for a switch to the transport format combination corresponding to the next higher bit-rate does not exceed [margin] dB below the maximum. If the UE has enough power to support that up-switch for at least [t2] ms the UE shall increase the data rate by increasing the number of transport blocks delivered to L1 and the physical layer increases the total transmission power by the predefined amount. This allows data that was buffered during bad channel conditions to be transmitted to Node B.

UE transport format selection shall be done according to [25.321] considering logical channel priorities. If the bit rate of a logical channel carrying data from a codec supporting variable rate operation is impacted by the transport format combination selection, the codec data rate shall be adopted accordingly.

Minimum requirements for t1, t2 (multiple of 10ms) and margin as well as maximum delay requirements for a transport format combination switch are defined in [25.133].

9.2 Site Selection Diversity Power Control (SSDT)

Site Selection Diversity Transmit Power Control (SSDT) is a form of power control for the downlink that can be applied while a UE is in soft handover (SHO). This section explains how SSDT works, and provides some examples

when SSDT should be used. Simulations have been performed comparing SHO with SSDT to normal SHO: results are presented in Appendix D.

In SHO, a UE has DL connections to more than one cell. Thus, one UE contributes to the DL interference in several cells. SSDT is a power control method that reduces the DL interference generated while the UE is in SHO. The principle of SSDT is that the best cell of the active set is dynamically chosen as the only transmitting site, and the other cells involved turn down their DPDCHs. The DPCCH is transmitted as normally (see figure below).

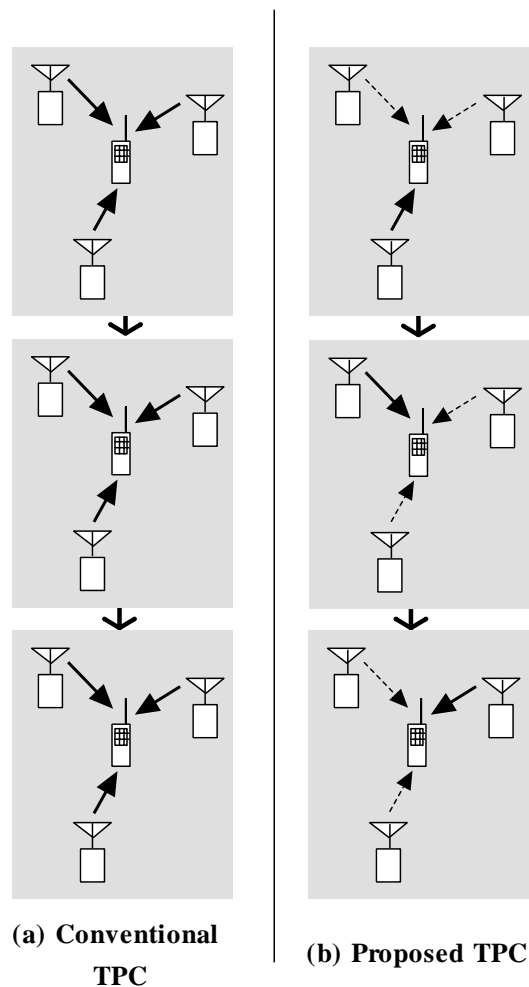

Figure 9-1: Principle of SSDT in comparison to conventional SHO

Each cell is given a temporary identification number. The UE measures the pilot power of the PCCPCHs, and chooses the best one as its 'primary' cell. The temporary id of this primary cell (the 'primary id') is transmitted on the UL DPCCH to all Node Bs of the active set. A cell that has been selected as primary station transmits its dedicated channels with the power necessary to reach the desired SIR target, whereas all other cells switch off their downlink DPDCH transmission. The 'primary id' is updated by the UE at a frequency of 5, 10 or 20ms. The frequency depends on the SSDT mode and is set by the UTRAN.

In order for the UE to continuously perform measurements and to maintain synchronisation, the 'secondary' cells continue to transmit pilot information on the DPCCH.

The prerequisite for using SSDT during an RRC connection or during a part of an RRC connection is that all Node B involved support SSDT. SSDT is controlled by L3 procedures. The control involves assignment of temporary ids, setting an SSDT mode and switching SSDT on or off. The control information itself (temporary ids) terminates in the L1 of Node B and UE respectively.

9.3 Examples of balancing Downlink power

9.3.1 Adjustment loop

Adjustment loop is a method for balancing downlink power among active set cells during soft handover. For adjustment loop, DL reference power P_{REF} and DL power convergence coefficient r ($0 < r < 1$) are set in the active set cells during soft handover so that the two parameters are common to the cells. For simplicity, DL powers of two cells are considered in this explanation. Adjustment loop works in addition to inner loop power control, and DL power at slot i of two cells, $P_1(i)$, and $P_2(i)$, are updated at a certain interval (typically in every slot as in this explanation) as follows:

$$P_1(i+1) = P_1(i) + (1 - r)(P_{REF} - P_1(i)) + S_{INNERLOOP1}(i)$$

$$P_2(i+1) = P_2(i) + (1 - r)(P_{REF} - P_2(i)) + S_{INNERLOOP2}(i)$$

where $S_{INNERLOOP1}(i)$ is the result of the inner loop power control.

The difference is derived from the two equations above if TPC error does not occur i.e. $S_{INNERLOOP1}(i)$ and $S_{INNERLOOP2}(i)$ are equal:

$$P_1(i+1) - P_2(i+1) = r(P_1(i) - P_2(i)) = r^i(P_1(1) - P_2(1))$$

Therefore the difference converges at zero when r is smaller than one. Simulation results are available in Appendix F.

10 Radio Link Surveillance

10.1 Mode Control strategies for TX diversity

10.1.1 TX diversity modes

TX diversity modes can be classified into two categories:

- Open loop modes
- Closed loop modes

In open loop mode no feedback information from the UE to the node B is transmitted in order to control how the signal is transmitted from the diversity antennas. This is in contrast to closed loop operation where UE sends feedback information to the Node B in order to optimise the transmission from the diversity antennas.

For a detailed description of TX diversity techniques in both FDD and TDD mode, refer to [L1 Spec].

10.1.2 Mode Control Strategies

10.1.2.1 DPCH

What mode will be used on DPCH and when is controlled by UTRAN. Important criteria for the mode control are the radio channel conditions. This is because depending on the radio channel different modes will provide the best performance.

Regarding the downlink performance there are two important factors which should be considered when doing mode control:

- Maximum Doppler frequency (i.e., speed of the UE).
- Number of multipath components.

Basically the UE could measure both of these and report back to UTRAN. As it happens both of these could be measured by UTRAN as well. Therefore, there is no need to signal this information from UE.

The use of TX diversity on dedicated channels is signalled to the UE in call set-up phase.

10.1.2.2 Common channels

Only open loop can be used for PCCPCH, SCCPCH, and AICH. For common channels the UE gets information about the use of TX diversity through system information broadcast on BCCH. Each of the different common channels above can utilise TX diversity irrespective of it is used on any of the other common channels.

11 Codec mode control

11.1 AMR mode control

The AMR speech codec consists of the multi-rate speech codec with eight source rates from 4.75 kbit/s to 12.2 kbit/s [12]. The change between the AMR specified rates could occur in the WCDMA in downlink, when traffic on the air interface exceeds the acceptable load, or when the connection based FER value indicates the bad quality of the connection. In uplink the corresponding change can be made when there is need to extend the uplink coverage area for speech by using several AMR modes or when the measured load on the air interface is reported to exceed the acceptable level.

In principle the speech coder is capable of switching its bit rate every 20 ms speech frame upon command. [12] However in practice the AMR mode adaptation is needed less frequently.

In WCDMA the network architecture has been defined to consist of two different network domains; UTRAN and Core Network (CN). Due to this definition and decisions about the location of the Transcoder, the AMR related functions are forced to divide between the previously mentioned network domains.

The location of the Transcoder in WCDMA was defined to be in the core network domain, and logically outside the Access Stratum. Thus also the location of the AMR speech codec is into the Core Network as well.

From the data transfer point of view the defined location of the encoder in the NW side means that at least all AMR coded data is going to be transmitted not only via Iub and air interface but also via Iu –interface (see Figure 11-1).

The functionality of the codec mode control on the contrary can not locate in the Transcoder, because this control entity needs information from the air interface to make decision about the valid AMR modes for the AMR related connections. Thus the only domain, which can provide this kind of information from the air interface to AMR codec mode control entity, is UTRAN. In GSM the control of the codec mode is provided by the BTS, but in WCDMA this solution is not applicable due to soft handover procedure defined for the dedicated traffic channels. Thus the AMR mode control function should be a part of the RNC functionality. In RNC the most natural place to perform the control of the AMR mode is RRM, because RRM is already responsible for reserving and controlling resources from the air interface. Thus all information, which is needed for the AMR adaptation, can be found from the RRM, which is a part of the current L3 functionality (see Figure 11-1).

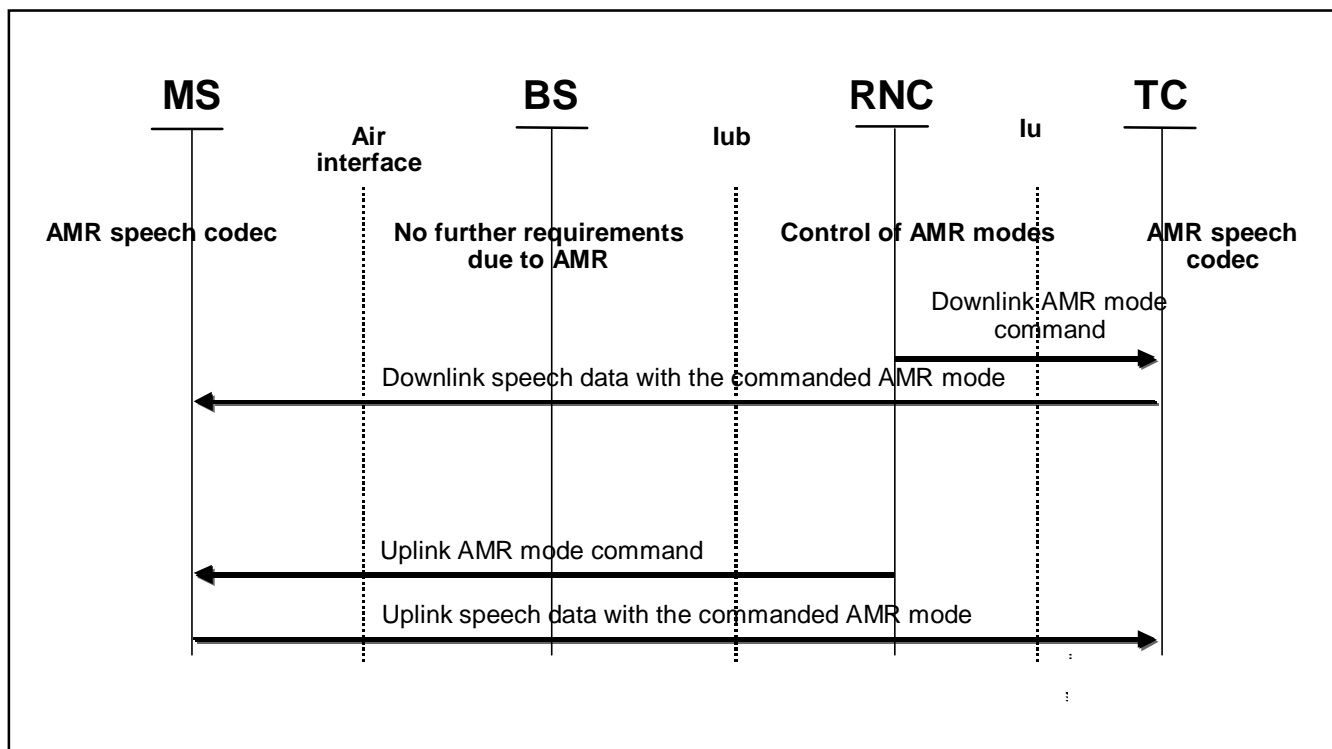

Figure 11-1

In the WCDMA the AMR mode adaptation is carried out with the aid of AMR mode control function, which is responsible for detecting the need of the AMR mode adaptation and to initiate required procedures to change the current AMR mode to the newly selected AMR mode. The AMR mode change request can be made with the aid of the AMR mode command, which is sent from the RNC either to the Transcoder for downlink data transfer or to the UE for uplink data transfer. In principle the supported AMR mode adaptation can be asymmetric, which implies the possibility to use different AMR modes in uplink and downlink during active speech call.

Therefore, the role of the RRM during the AMR coded speech call will be basically the role of the supervisor of the connection.

The AMR mode command is used to change the current AMR mode to the new one, which suits better to the conditions on the air interface. The command is sent from the UTRAN to the appropriate AMR codec, which locates either in the transcoder or in the UE. In which encoder the command is sent depends on direction of the data transmission. If the AMR mode - in question - is intended to be used in downlink the command is sent to the encoder inside the transcoder via Iu -interface, whereas AMR code needed on uplink is sent to the UE through air interface.

The initialisation of AMR mode command will base on load information, which has been received from the air interface. The following table shows the required information during the AMR mode adaptation in WCDMA:

Information used in AMR control	Load
Downlink information	BS reports total BS transmission power
Uplink information	BS measurers total interference level

When RRM indicates the need for the AMR mode adaptation, RRC may generate the requested AMR mode command and send it to the encoder, or RRC may request MAC -d to perform the same functions. Which layer is used depend on whether the AMR mode command is intended to use on uplink or on downlink, and whether inband or outband signalling is used for transferring the command from the UTRAN to the encoder.

For the downlink, the AMR mode command from RNC to TC is realised as inband.

Transport format for the transport channel carrying the different classes of AMR source codec provides an unambiguous mapping of the codec mode that is used.

Annex A: Simulations on Fast Dynamic Channel Allocation

A.1 Simulation environment

The presented simulations are performed in the following environments and services according to the requirements in the following documents:

- ETSI TR 101 112, Selection procedures for the choice of radio transmission technologies of the Universal Mobile Telecommunications System UMTS (UMTS 30.03), version 3.2.0, April 1998.
- Seppo Hämäläinen, Peter Slanina, Magnus Hartman, Antti Lappeteläinen, Harri Holma, Oscar Salonaho, A Novel Interface Between Link and System Level Simulations, Acts Mobile Communications Summit '97, pp. 599-604, Aalborg/Denmark, Oct 7-10, 1997.

Absolute capacities [kbit/s/MHz/cell] were published in:

- ETSI Tdoc SMG2 306/98, UTRA TDD Link Level and System Level Simulation Results for ITU Submission, Source: Siemens, Helsinki, Sep 8-11, 1998.
1. Macro (Vehicular) environment for the UDD 144 kbit/s service.
 2. Micro (Outdoor-to-Indoor Pedestrian) environment for the UDD 384 kbit/s service.

A.2 Results

The relative load of the cell is used for the abscissa (horizontal axis) in all of the plots. Here, a relative load of 100% refers to the maximum cell load obtainable with code-pooling under the ETSI unsatisfied user criterion (in accordance with ETSI TR 101 112). Vertically, the percentage of unsatisfied users is shown.

A.2.1 Macro UDD 144

In the Macro environment the UDD 144 service is simulated with Hybrid ARQ Type II-III using an adaptive code-rate between 1 and $\frac{1}{2}$.

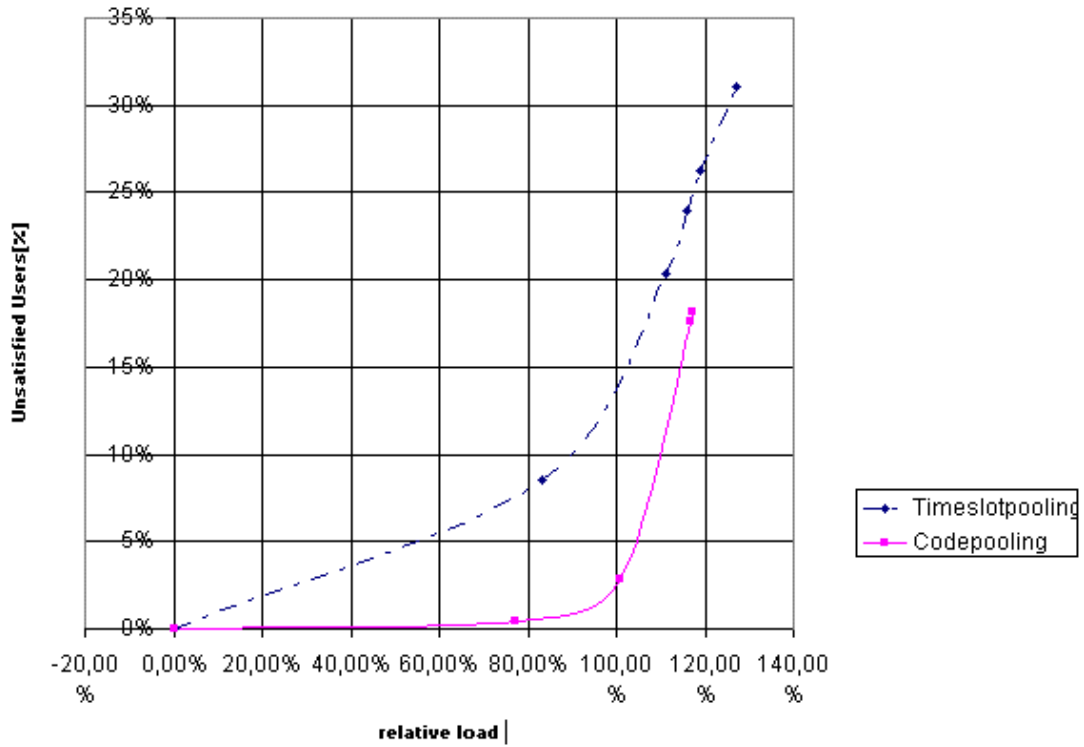

Figure A-1

A.2.2 Micro UDD 384

In the Micro environment the UDD 384 service is simulated with Hybrid ARQ I using code-rates 1 and 2/3.

A.2.2.1 Code rate 1

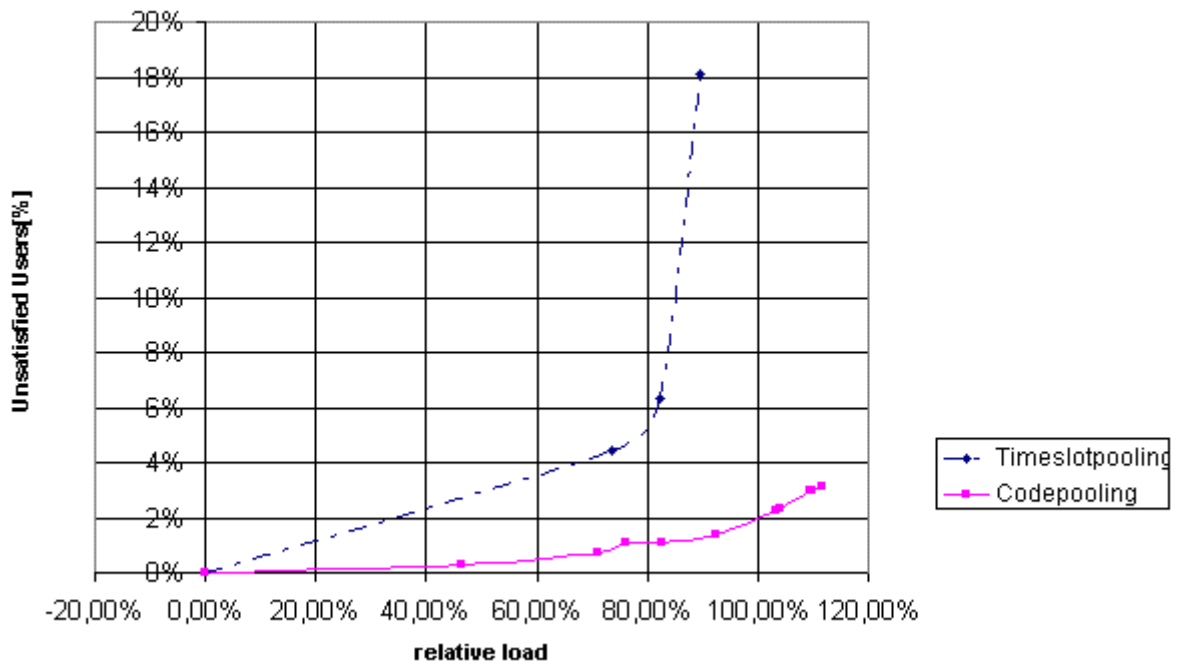

Figure A-2

A.2.2.2 Code rate 2/3

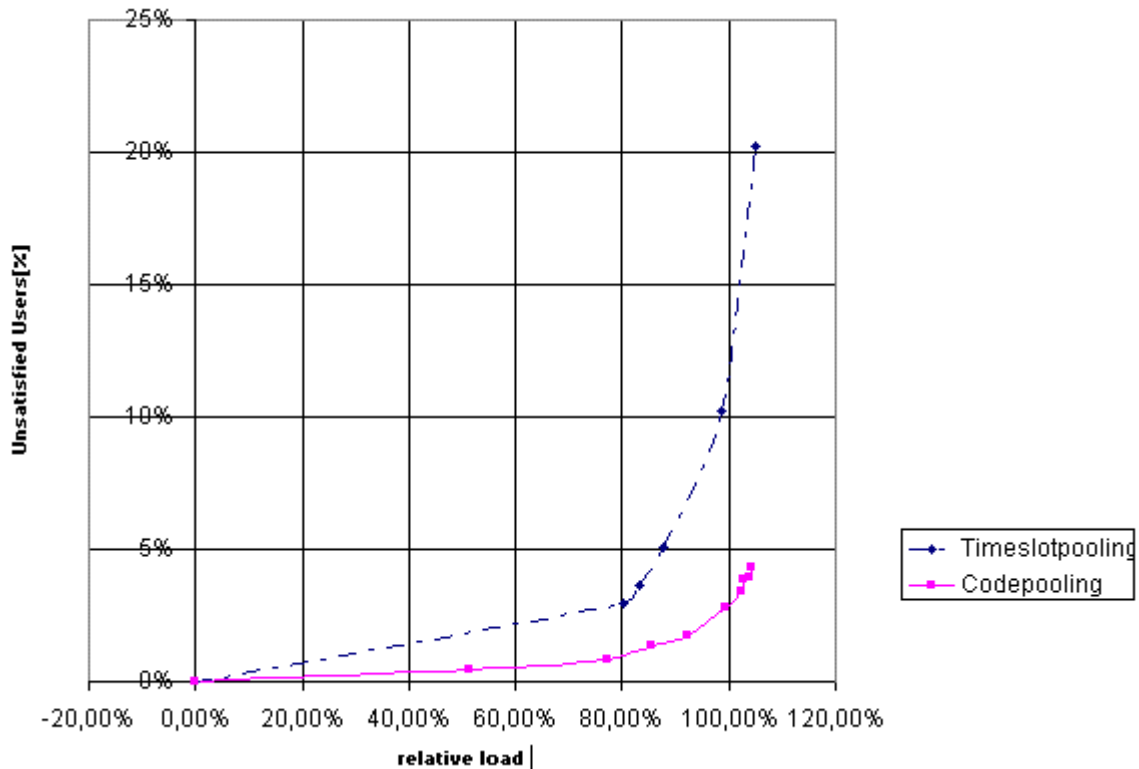

Figure A-3

A.3 Conclusions

With both Hybrid ARQ I and Hybrid ARQ II code pooling performs better than time slot pooling. This is explained as follows: Code-pooling performs better in conjunction with the initial transmission of Hybrid ARQ Type II-III. Timeslot pooling suffers from a high probability of low CIR in at least one of the used timeslots of the PDU. This leads to a high initial transmission failure probability because the initial transmission is sent almost uncoded. When code-pooling is applied, the whole PDU depends on the same interference level on all codes: the probabilities of low CIR on each spreading-code within the same timeslot are strongly coupled.

- The probability of PDU transmission failure for code-pooling is approximately the same as the probability of low CIR in a single timeslot.
- The probability of PDU transmission failure for timeslot-pooling is approximately the same as the probability of low CIR in at least one of the used timeslots.

This advantage of code-pooling results in lower numbers of unsatisfied users. These results clearly recommend that the DCA prefers code pooling over timeslot pooling for UDD packet data in TDD mode.

Annex B: Radio Bearer Control – Overview of Procedures: message exchange and parameters used

B.1 Examples of Radio Bearer Setup

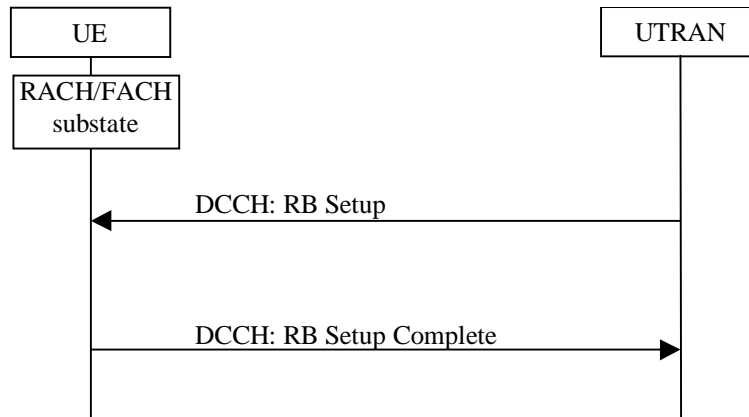

Figure B-1: Radio Bearer setup on common transport channel

B.1.1 RRC Parameters in RB Setup

This message includes **RB identity** for the new RB and **RLC info**. It also includes **two different multiplexing configurations** giving the transport channel this RB could be mapped onto. One configuration to be used on a common transport channel and one for a dedicated transport channel.

For the common transport channel this message includes a new **Transport format set for FACH**, and a **Transport format set for RACH**.

For the dedicated transport channel (pre-configured, not yet used) this message includes the **transport formats for DCH1 and DCH2**, and also the **transport format combinations** used in e.g. B.2.1, after the switch.

B.1.2 RRC Parameters in RB Setup Complete

This message only includes the message type.

B.2 Examples of Physical Channel Reconfiguration

This RRC procedure is used to reconfigure the Physical channel and can by that also trigger Transport channel type switching.

Below several examples of Physical Channel reconfigurations are shown, triggered by different amount of UL or DL data.

B.2.1 Increased UL data, with switch from RACH/FACH to DCH/DCH

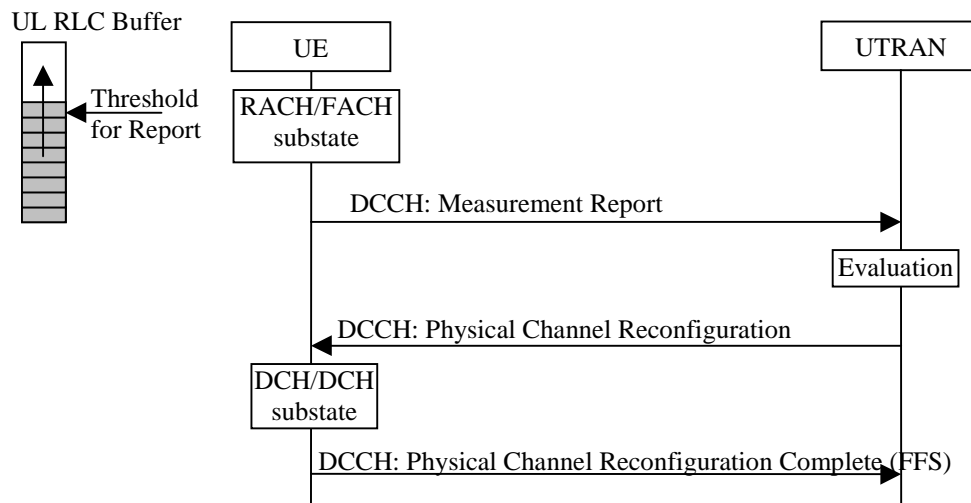

Figure B-2: Physical channel reconfiguration triggered by increased UL data and with a switch from RACH/FACH to DCH/DCH

B.2.1.1 RRC Parameters in Measurement Report

This message includes a **Measurement Identity number** so that UTRAN can associate this report with a Measurement control message. It also includes the **Measurement result** stating what triggered the report and optionally the RLC buffer payload.

B.2.1.2 RRC Parameters in Physical Channel Reconfiguration

This message includes **DL channelisation codes** and **DL scrambling code** for the DPCH. It also includes **UL channelisation codes** and **scrambling code** for the DPCH.

B.2.1.3 RRC Parameters in Physical Channel Reconfiguration Complete

This message only includes the message type.

B.2.2 Increased DL data, no Transport channel type switching

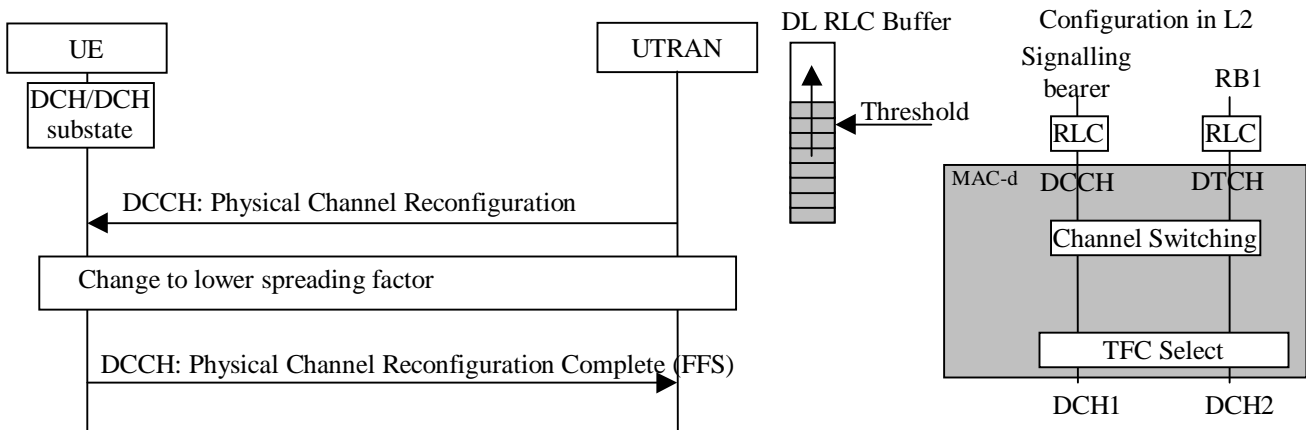

Figure B-3: Physical channel reconfiguration triggered by increased DL data and configuration in UTRAN DL

B.2.2.1 RRC Parameters in Physical Channel Reconfiguration

This message includes **new DL channelisation codes** for the DPCH with lower spreading factor for all cells that the UE is connected to.

B.2.2.2 RRC Parameters in Physical Channel Reconfiguration Complete

No identified parameters

B.2.3 Decrease DL data, no Transport channel type switching

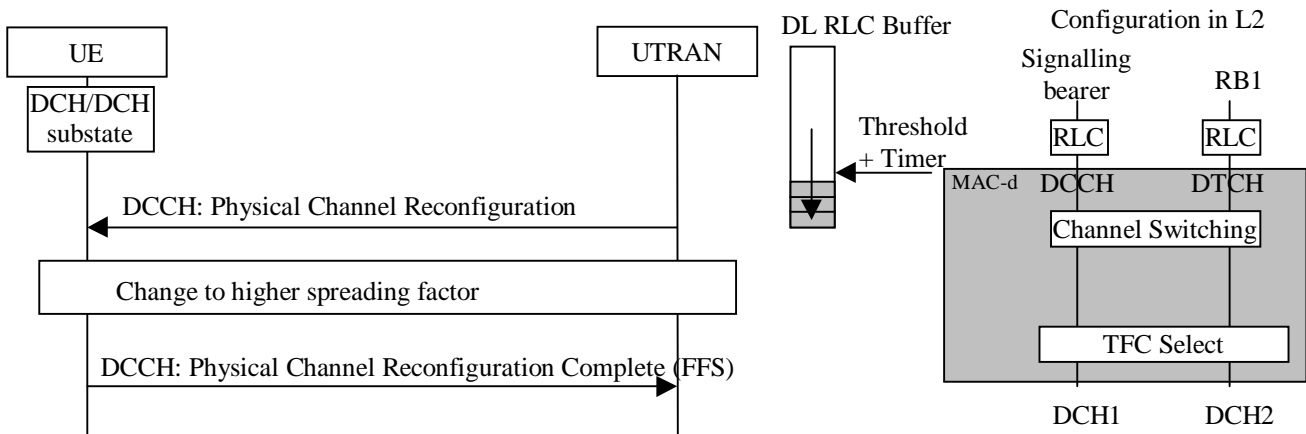

Figure B-4: Physical channel reconfiguration triggered by decreased DL data and configuration in UTRAN DL

B.2.3.1 RRC Parameters in Physical Channel Reconfiguration

This message includes **new DL channelisation codes** for DPCH with higher spreading factor for all cells that the UE is connected to.

B.2.3.2 RRC Parameters in Physical Channel Reconfiguration Complete

This message only includes the message type.

B.2.4 Decreased UL data, with switch from DCH/DCH to RACH/FACH

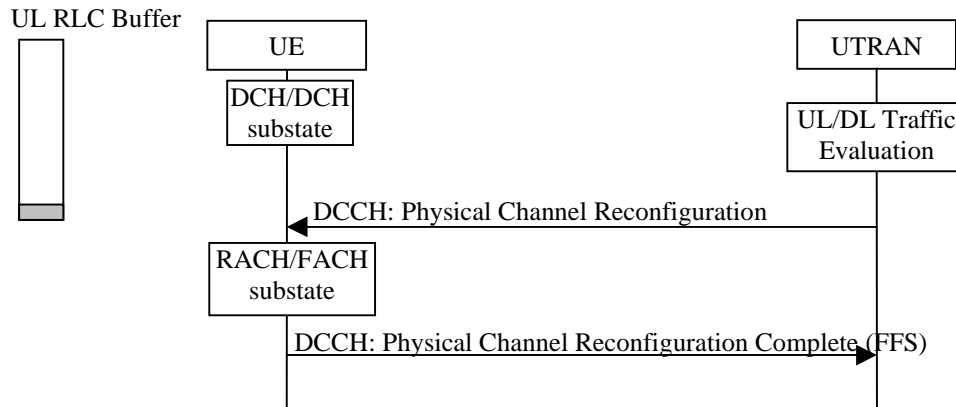

Figure B-5: Physical channel reconfiguration triggered by decreased UL data and with a switch from DCH/DCH to RACH/FACH

B.2.4.1 RRC Parameters in Physical Channel Reconfiguration

This message includes a **PRACH spreading factor** for the UL i.e. stating the minimum spreading factor to be used, and the **preamble signatures** that are allowed. Further, for the PRACH which **access slots** that are allowed and the **preamble spreading code** is included.

For the DL the message includes **scrambling code**, i.e. indicating to which cells FACH the UE should be connected to, and a **channelisation code** for the secondary CCPCH.

NOTE: The common channel parameters are the same that is transmitted on the BCCH. The reason to send it in this message is to remove the necessity for the UE to read BCCH at this switch.

B.2.4.2 RRC Parameters in Physical Channel Reconfiguration Complete

This message only includes the message type.

B.3 Examples of Transport Channel Reconfiguration

B.3.1 Increased UL data, with no transport channel type switching

In the example below, the UE is allowed to send more data in the UL when on dedicated transport channel, although the common transport channel configuration is still the same. To make use of the new transport format combinations the physical channel must also be reconfigured to allow a lower spreading factor.

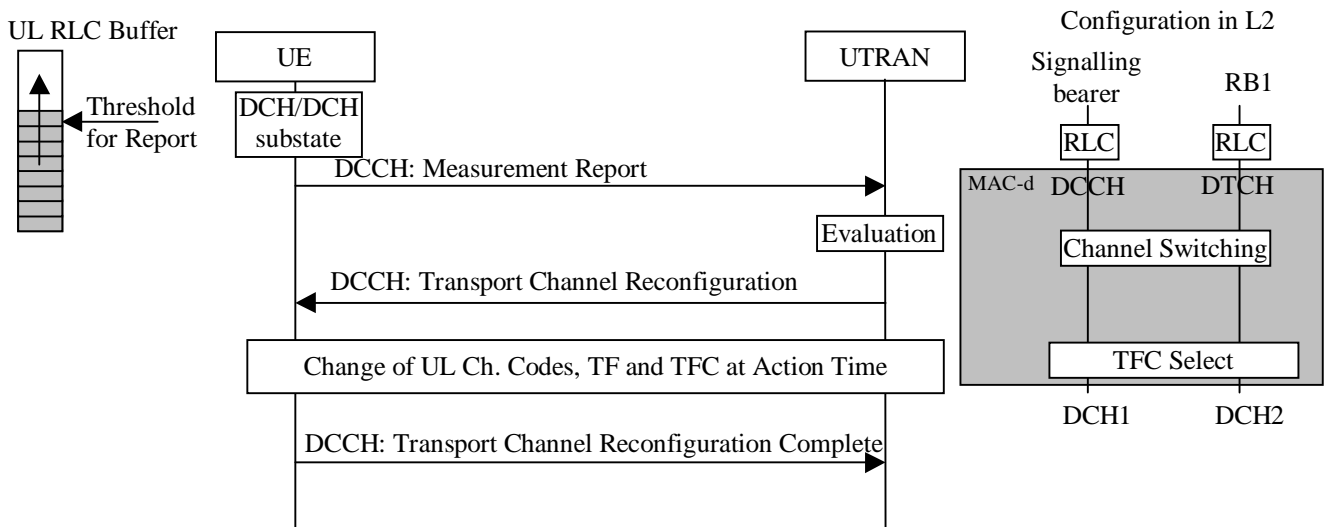

Figure B-6: Transport channel reconfiguration triggered by increased UL data and configuration in UTRAN DL

B.3.1.1 RRC Parameters in Measurement Report

This message includes a **Measurement Identity number** so that UTRAN can associate this report with a Measurement control message. It also includes the **Measurement result** stating what triggered the report and optionally the RLC buffer payload.

B.3.1.2 RRC Parameters in Transport Channel Reconfiguration

This message includes a new **Transport format set** for DCH2 and a new **Transport format combination set**. An **Activation time** must also be included if the different TFCIs can not coexist during the reconfiguration.

It also includes **UL channelisation codes** for the DPCH.

B.3.1.3 RRC Parameters in Transport Channel Reconfiguration Complete

This message only includes the message type.

B.3.2 Decreased DL data, with switch from DCH/DCH to RACH/FACH

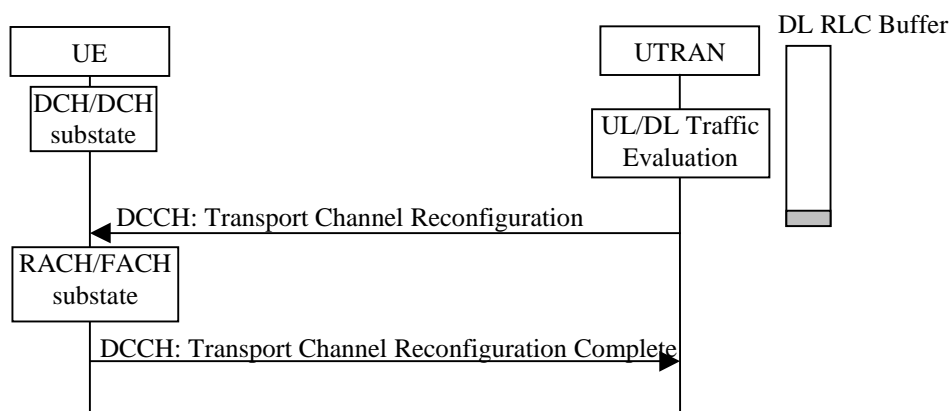

Figure B-7: Transport channel reconfiguration triggered by decreased DL data and with a switch from DCH/DCH to RACH/FACH

B.3.2.1 RRC Parameters in Transport Channel Reconfiguration

This message includes new **Transport format set for RACH**, a **PRACH spreading factor** i.e. stating the minimum spreading factor to be used, and the **preamble signatures** that are allowed. Further, for the PRACH which **access slots** that are allowed and the **preamble spreading code** is included.

For the DL the message includes a new **Transport format set for FACH**, the **scrambling code**, i.e. indicating to which cells FACH the UE should be connected to, and a **channelisation code** for the secondary CCPCH.

NOTE: The common channel parameters are the same that is transmitted at the BCCH. The reason to send it in this message is to remove the necessity for the UE to read BCCH at this switch.

B.3.2.2 RRC Parameters in Transport Channel Reconfiguration Complete

This message only includes the message type.

B.4 Examples of RB Reconfiguration

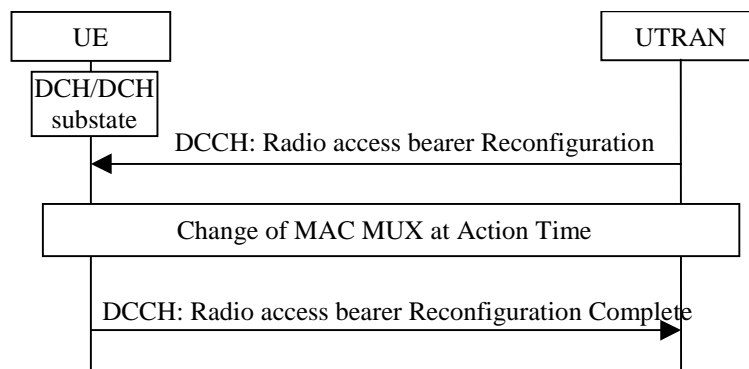

Figure B-8: RB Reconfiguration

B.4.1 RRC Parameters in Radio Bearer Reconfiguration

This message includes a multiplexing option with Transport channel identity DCH2 for both RB1 and RB2, stating that both these RBs should use the same transport channel. For each of these two RBs a **Logical channel identity value** and a **priority** must be given to define the MAC MUX.

Also included is a new **Transport format set** for DCH2 and a new **Transport format combination set** (both for UL and DL if the multiplexing is changed both in UL and DL).

It is also possible to reconfigure the physical channel and include new **channelisation codes** for the DPCH with different spreading factor for all cells that the UE is connected to.

B.4.2 RRC Parameters in Radio Bearer Reconfiguration Complete

This message only includes the message type.

Annex C: Flow-chart of a Soft Handover algorithm

In this Appendix a flow-chart of the Soft Handover algorithm described in section 6.1.4.1 is presented.

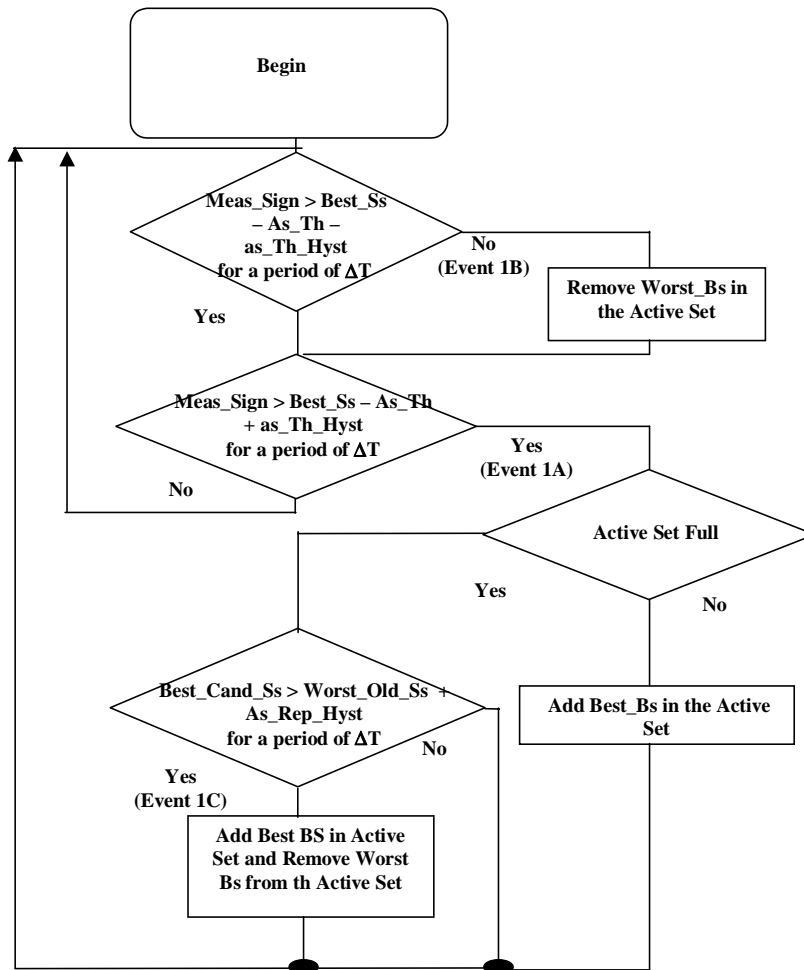

Figure C-1: flow-chart of a Soft Handover algorithm

Annex D: SSDT performance

Site Selection Diversity Transmit Power (SSDT) is described in section 10.2.

Computer simulations were carried out to investigate the behaviour of SSDT under ETSI&ITU-R guidelines for IMT-2000 RTT evaluation. The results are compared to a conventional power control method, where the transmit power of all BS involved is controlled so that the correct target SIR value is reached.

The figure below shows capacity versus Doppler frequency for SSDT and conventional TPC (normal SHO). The simulations show that SSDT is superior to normal SHO at low speed, and that increases capacity by reducing overall interference. The capacity gains are approximately 40% without UE's diversity and 50% with UE's diversity at walking speed. At high mobile speed, the advantage of SSDT gradually diminishes. The performance degradation of SSDT at higher speed is caused by the limited update frequency of the primary cell id.

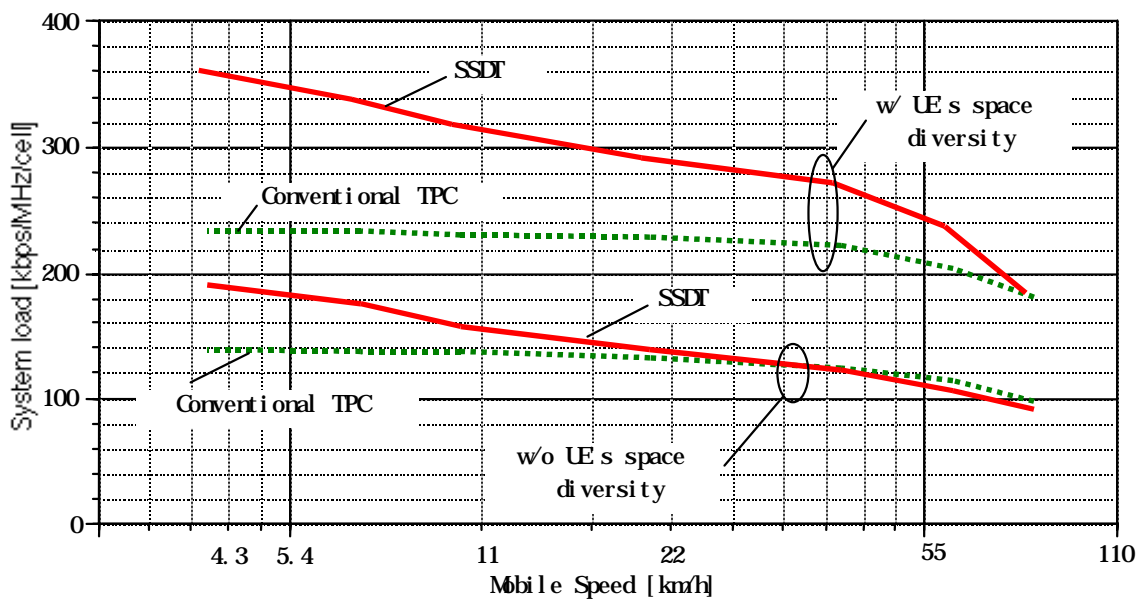

Figure D-1: Capacity versus Doppler frequency for SSDT and conventional TPC (normal SHO)

Annex E: Simulation results on DL Variable Rate Packet Transmission

E.1 Simulation assumption

The simulation model is based on the ARIB's model used for RTT proposal. Following are detailed assumptions:

- down-link, vehicular environment system-level simulation (ITU model);
- perfect SIR estimation (no delay on SIR estimation);
- UDD144k users and SPEECH users are considered;
- voice activation of 50 % for SPEECH service;
- traffic call model is not introduced for UDD service (continuous transmission).

Other simulation parameters are shown in Tables 17.1 and 17.2.

Table E-1: Environment models

Cell radius	1000 m
Site to site separation	3000 m
Cell layout	wrap around
Data sample cell	all cells
# of sectors	3
UE speed	120 km/h

Table E-2: Power setting and other parameters

	SPEECH 8kbps	UDD 144kbps
Diversity	No	No
Processing gain	512 (27.1dB)	67.4 (18.3dB)
TCH max. TX power	30 dBm	30 dBm
TCH min. TX power	10 dBm	10 dBm
BCH TX power	30 dBm	30 dBm
HO algorithm settings		
DHO windows	3 dB	N/A
Active set update rate	0.5 second	0.5 second
Active set max. size	2	1
Required Eb/No	8.8 dB	2.9 dB
TCH allowable TX power (TXPOW_ALLOWABLE)	-	30, 27, 24 dBm
Number of users	60, 62, 64, 68, 70	5

E.2 Simulation results

Tables 17.3, 17.4 and 17.5 are simulation results for TXPOW_ALLOWABLE of 30, 27 and 24 dBm, respectively. In these tables, 'satisfied user' means the user having sufficiently good quality, i.e., the required Eb/No is satisfied, more than 95% of the session time. The results shows that:

- Compared with "Fixed Rate", "Variable Rate" can achieve the same or higher data rate as well as better quality for both services.
- "Variable Rate" can accommodate more users by allocating a lower power threshold for high-rate packet users.

- "Variable Rate" can control the average transmission power not only for UDD144k users but also for SPEECH users. This means that "Variable Rate" can keep the system stable by allocating an appropriate power threshold (TXPOW_ALLOWABLE).

Because of these advantages, the system may tolerate high-power emergent users.

Table E-3: Simulation results for TXPOW_ALLOWABLE = 30 dBm

Number of users (SPEECH + UDD144k)	Fixed Rate				Variable Rate				
	SPEECH		UDD144k		SPEECH		UDD144k		
	satisfied user	Average TXPOW [dBm]	Satisfied user	average TXPOW [dBm]	satisfied user	average TXPOW [dBm]	satisfied user	average TXPOW [dBm]	average data rate [times]
60 + 5	100 %	21.9	93.6 %	25.8	97.58 %	23.8	90.82 %	28.6	1.59
62 + 5	100 %	22.8	41.6 %	26.6	99.59 %	28.6	97.26 %	28.6	1.44
64 + 5	-	-	-	-	99.97 %	28.6	99.54 %	28.6	1.31
66 + 5	-	-	-	-	100 %	28.6	100 %	28.6	1.18
68 + 5	-	-	-	-	100 %	28.6	99.98 %	28.6	1.04
70 + 5	-	-	-	-	99.94 %	28.6	100 %	28.6	0.91

Table E-4: Simulation results for TXPOW_ALLOWABLE = 27 dBm

Number of users (SPEECH + UDD144k)	Fixed Rate				Variable Rate				
	SPEECH		UDD144k		SPEECH		UDD144k		
	satisfied user	Average TXPOW [dBm]	satisfied user	average TXPOW [dBm]	satisfied user	average TXPOW [dBm]	satisfied user	average TXPOW [dBm]	average data rate [times]
60 + 5	100 %	21.9	93.6 %	25.8	99.98 %	25.6	99.92 %	25.6	1.29
62 + 5	100 %	22.8	41.6 %	26.6	100 %	25.6	100 %	25.6	1.19
64 + 5	-	-	-	-	100 %	25.6	100 %	25.6	1.08
66 + 5	-	-	-	-	100 %	25.6	100 %	25.6	0.97
68 + 5	-	-	-	-	100 %	25.6	100 %	25.6	0.85

Table E-5: Simulation results for TXPOW_ALLOWABLE = 24 dBm

Number of users (SPEECH + UDD144k)	Fixed Rate				Variable Rate				
	SPEECH		UDD144k		SPEECH		UDD144k		
	satisfied user	Average TXPOW [dBm]	satisfied user	average TXPOW [dBm]	satisfied user	average TXPOW [dBm]	satisfied user	average TXPOW [dBm]	average data rate [times]
60 + 5	100 %	21.9	93.6 %	25.8	100 %	22.6	100 %	22.6	0.97
62 + 5	100 %	22.8	41.6 %	26.6	100 %	22.6	100 %	22.6	0.88
64 + 5	-	-	-	-	100 %	22.6	100 %	22.6	0.79

Annex F: Simulation results on Adjustment loop

F.1 Simulation conditions

The performance of adjustment loop is evaluated by means of computer simulation. The assumptions of the simulation are as follows:

- Active set is determined when a call is originated. During the call, sector average of path loss does not change, and the active set is not updated.
- Maximum active set size is three. Relative threshold for soft handover is 6 dB.
- Initial DL power is set to a value common to all active set cells.
- During a call, DL power is not synchronised by messages from RNC.
- Average holding time is 10 sec.
- Path loss of 3.5th power law, log-normal shadowing, and equal level 4 path Rayleigh fading are considered.
- Both uplink and downlink power is updated by inner loop power control in every slot.
- Delay of inner loop power control is one slot.
- Outer loop power control is employed, in which target FER is 0.01.
- Step size of inner loop power is 1 dB.
- When the SIR of TPC command is smaller than a threshold, the degraded TPC command is not used for inner loop power control.
- Reception error of TPC commands is generated in accordance with received SIR.
- Power control range is 20 dB.
- DL reference power P_{REF} is the centre value of power control range.
- DL power convergence coefficient r is 0.96.

F.2 Simulation results

Figure F-1 shows average of DL power difference among cells during soft handover, Figure F-2 shows FER, and Figure F-3 shows average DL power of all calls. During soft handover, DL power is the sum of DL powers of the active set cells. In these figures, performance with adjustment loop (ON) is compared with the performance without adjustment loop (OFF). The performance depends on the DL reference power, i.e. the centre value of the power control range. In this result, ratios of active set size of two and three were both 0.22, and both degraded TPC command rate and TPC error rate were approximately 2 percent.

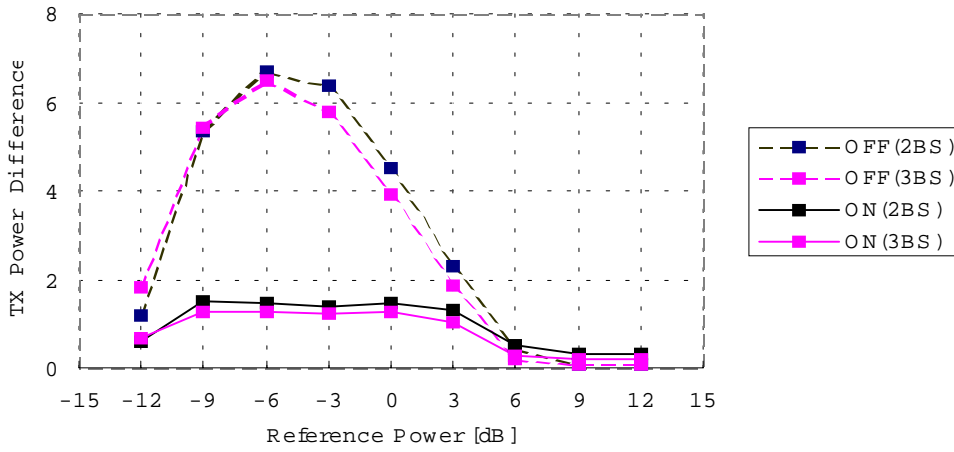

Figure F-1: DL power difference

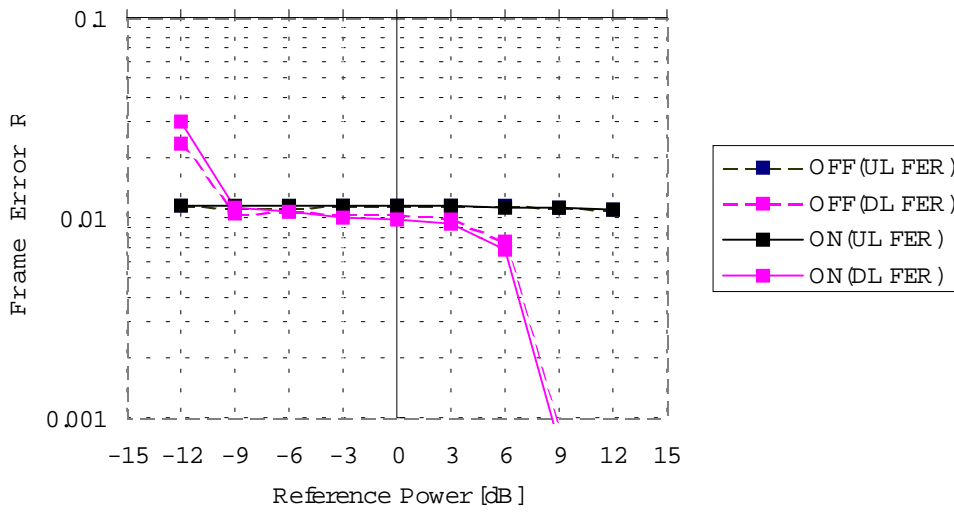

Figure F-2: Frame Error Rate

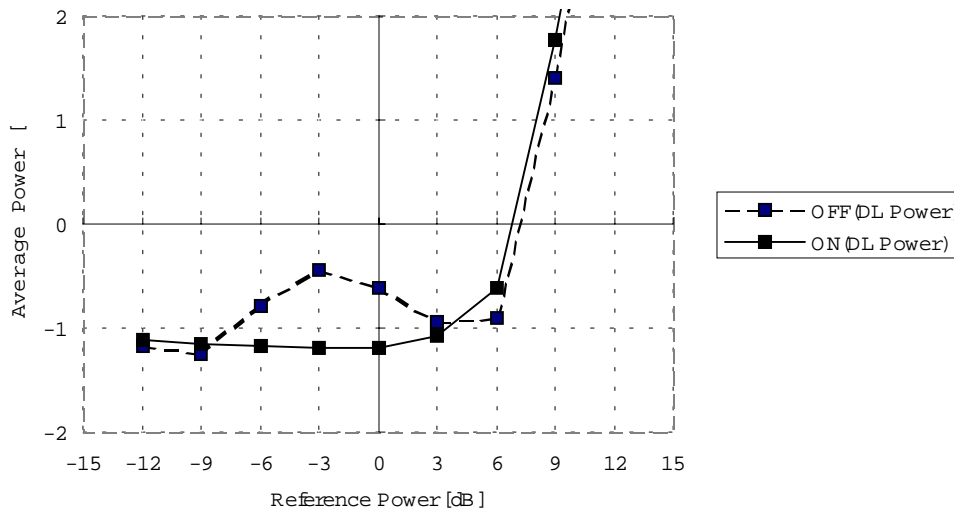

Figure F-3: Average DL power

F.3 Interpretation of results

When the reference power is between -9 dB and 6 dB, FER is maintained at a target value and average DL power stays relatively low. However, when the reference power is less than -9 dB, FER becomes large due to small maximum DL power. On the other hand, when the reference power is more than 6 dB, average DL power is increased due to large minimum DL power.

When adjustment loop is not employed, average DL power depends on the centre value of power control range. With adjustment loop, average DL power is not sensitive to the centre value of power control range. This means that it is possible to keep DL power low quite easily.

With adjustment loop, it is possible to eliminate power drifting problem without the need of frequent signalling of DL Reference Power, and without negative impact on DL inner loop power control.

During soft handover, DL Reference Power is reported from RNC to Node-Bs in NBAP messages. If synchronised Radio Link Reconfiguration is not used, power drifting cannot be eliminated since it is not possible to set the DL Reference Power at all Node-Bs at the same time. If synchronised Radio Link Reconfiguration is used, there is a high probability that the difference of the DL Reference Power and the current DL power is large due to large delays. In such cases, if DL power is set equal to DL Reference Power in a slot in each Node-B, the DL power may become too low or too high. Therefore this may have significant negative impact on DL inner loop power control. It should be also noted that frequent signalling of DL Reference Power will have significant increase of control traffic from RNC to Node-B.

With adjustment loop, DL power adjustment is much smaller than a step of inner loop power control even when the difference of the DL Reference Power and the current DL power is large. This means that it is possible to achieve the high performance of DL inner loop power control.

Annex G: Simulation results for CPCH

This appendix presents the results of CPCH simulations performed with the OPNET Modeller tool for various traffic loading and cell capacity scenarios. Simulation assumptions and results are presented. The last section of the appendix presents RRM strategies based on the simulation results.

G.1 Simulation Assumptions

- Results of Link Level Simulations with ITU channel model is used.
- The preamble detection probability as a function of SNR.
- Window-based and timer-based ARQ is used. So it was captured end-to-end delays.
- 50-200 mobiles are randomly distributed in the coverage area of one cell.
- The access Preamble ramp-up and the collision resolution steps are simulated.
- Each packet is processed serially and independently of others, i.e. aggregation of packets in the UE is not simulated.
- The following tuneable parameters exist in the simulations:
 - N_Max_Frames: maximum length in frames of individual packet.
 - Number of ramp-ups max: number of AP power ramp up cycles without APCH response before access is aborted and packet transmission fails.
 - Traffic model: includes packet inter-arrival time, session inter-arrival time, # of packets per packet call, number of packet calls per session, Session length, average packet size, etc.
 - Three various CPCH channel selection algorithms.
- The following traffic model is used in the simulations:
 - Average packet size: E-mail application 160, 480, 1000 bytes.
 - # of packets in a packet call = 15.
 - Packet call inter-arrival time = 0,120.
 - # of packet calls within a session =1.
 - Average inter-packet arrival time = 30, 100, 200 ms.
 - CPCH channel data rates: 2.048 Msps (512 kbps), 384 ksps (96 kbps), 144 ksps (36 kbps), 64 ksps (16 kbps).
 - Session arrival = Poisson.
- The following results are captured:
 - End-to-End Delay, D(e-e), includes UL retransmissions and DL ACK transmission.
 - Unacknowledged Mode End-to-End Delay, D(un).
 - RLC queuing delay, QD.
 - Radio Access Delay, AD.
 - MAC collisions, event count for event in which 2 UE attempt access to same CPCH channel in same slot.

- Throughput (S1) includes ARQ re-transmissions/ excludes detected MAC collisions/excludes undetected collisions as well.
- Unacknowledged Mode Throughput (S2) excludes ARQ re-transmissions / excludes MAC collisions.
- Offered Load (ρ), total offered traffic normalised to total available capacity (bandwidth).
- Undetected collisions per sec.
- Detected collisions per sec.

G.2 CPCH Channel Selection Algorithms

The three CPCH channel selection algorithms are: Simple, recency, idle-random.

G.2.1 Simple CPCH channel selection algorithm

In this method, the UE monitors the available capacity and the highest available rate from the Base Node. The UE then picks a CPCH channel and a slot randomly and contends for the CPCH.

G.2.2 The recency table method

In this method, the UE monitors the AP-AICH and constructs a recency table, which includes time-stamps, which aid the selection of the CPCH channel. The simulation assumes perfect knowledge of the transmission of AP-AICH (CPCH channel transition from idle to busy) from the base Node. In reality, there will be discrepancies in the information in the table since the UE is required to receive FACH and DL-DPCCH (while transmitting on the UL CPCH) and thus will may not be able to receive all AP-AICHs. The UE selects the CPCH channel with the oldest AP-AICH timestamp.

G.2.3 The idle-random method

In this method, the UE monitors the idle-AICH (channel idle) and AP-AICH (channel busy) and has perfect information on the availability of the CPCH channels. The UE monitors the AP-AICH and CD-AICH for 10 ms. then it picks a CPCH channel randomly from the available ones in the desired data rate category. Note that this method is sensitive to back-off methods. When the traffic load is high and there are multiple CPCH channels, this method outperforms the other methods given the right back-off parameters.

G.3 Simulation Results

G.3.1 Cases A-B: Comparison of idle-random method and the recency method for 30 ms packet inter-arrival time, 480 bytes, and 6 CPCH channels, each @384 ksps

36 cases were ran over to compare the throughput delay performance of the two methods when the packet inter-arrival time is 30 ms. This was done for various packet lengths (158 bytes, 480 bytes, 1000 bytes, 2000 bytes), various rates (6 CPCH @ 384 ksps, 16 CPCH @ 144 ksps, 32 CPCH @ 64 ksps), various N_Max_Frames (8,16,24,32,64), and the three CPCH channel selection algorithms. In all cases, the idle-random method performed better. When the packet inter-arrival time was increased, the throughput delay performance of the recency method almost overlapped with the idle-random case (see Scenarios C-D-E).

Results presented here compare idle-random method and the recency method for 30 ms packet inter-arrival time, 480 bytes, and 6 CPCH @384 ksps:

Table G-1: Idle random case

\square	S1	D(e-e)
.34	.33	.3
.44	.42	.338
.53	.5	.375
.65	.70	.430
.95	.76	.92

Table G-2: Recency table case

\square	S1	D(e-e)
.36	.335	.36
.45	.42	.375
.67	.583	.55
.97	.76	1.73

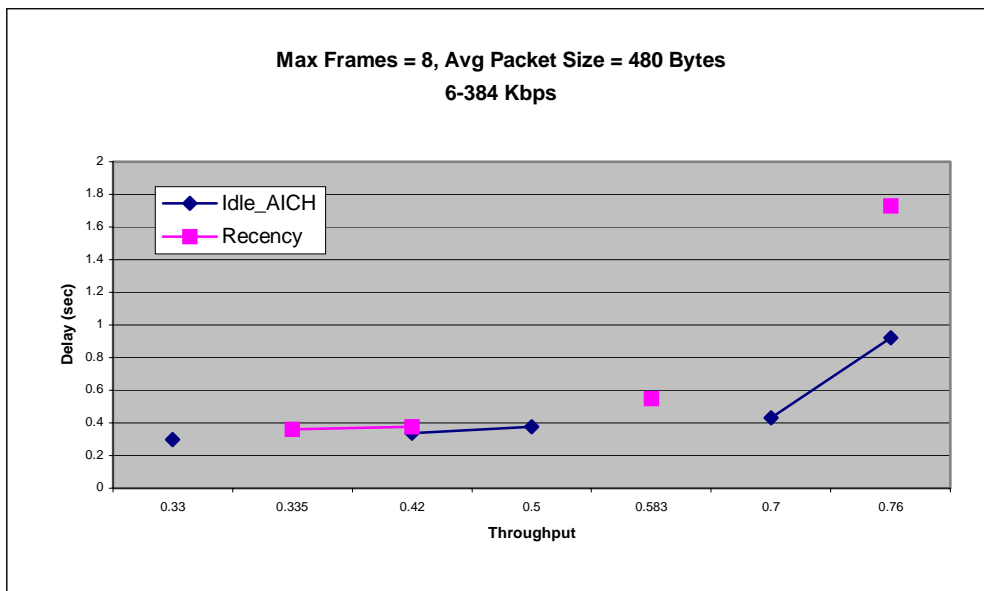

Figure G-1: Delay vs. Throughput

G.3.2 Case C-D-E: Comparison of the three methods for multiple CPCH

Recency table and the idle random methods out-perform the simple case significantly. However, the recency method performs almost as well as the idle-random case in these simulation runs for two reasons: 1) the recency table case in the simulation does not have any discrepancies in its information 2) the back-off for idle-random is not optimised and therefore it performs slightly worse when the packet inter-arrival time is high (e.g., 100 ms).

At D (un) of 300 ms, we have the following throughputs:

Simple case, S1 = .55.

Recency table: S1 = .8.

Idle-random S1 = .78.

Table G-3, Table G-4, Table G-5 provide results for the comparison of the three CPCH channel selection algorithms considering:

Packet inter-arrival time 100 ms.

Maximum frame per packet 8.

Average packet size 480.

12 channels: 4 – 384 CPCH; 4 – 144 CPCH; 4 – 64 CPCH.

Table G-3: E-mail_1_with the simple algorithm

Sess	ρ	S1	D(un)	QD	AD	TD	MAC Collision
20	0.310	0.280	0.121	0.070	0.013	0.038	677,000.000
16	0.390	0.360	0.155	0.100	0.015	0.039	106,000.000
10	0.630	0.550	0.300	0.237	0.020	0.042	266,000.000
8	0.776	0.650	0.660	0.589	0.025	0.045	436,700.000
6.8	0.923	0.76	1.324	1.245	0.033	0.046	714,700.000
6.6	1.00	0.812	3.23	3.15	0.036	0.047	983,300.000

Table G-4: E-mail_1_with the recency table algorithm

Sess	ρ	S1	D(un)	QD	AD	TD	MAC Collision
20	0.283	0.280	0.110	0.062	0.009	0.038	96,500.000
16	0.380	0.377	0.116	0.069	0.010	0.038	162,000.000
12	0.477	0.470	0.131	0.081	0.012	0.038	251,000.000
10	0.566	0.565	0.140	0.088	0.014	0.038	354,700.000
8	0.779	0.736	0.203	0.149	0.016	0.038	733,300.000
7.1	0.846	0.800	0.290	0.235	0.017	0.038	860,000.000

Table G-5: E-mail_1_with the idle random algorithm

Sess	ρ	S1	D(un)	QD	AD	TD	MAC Collision
20	0.282	0.280	0.102	0.056	0.007	0.039	65,100.000
16	0.351	0.350	0.118	0.072	0.007	0.039	89,000.000
12	0.458	0.454	0.124	0.076	0.008	0.040	137,500.000
10	0.558	0.554	0.148	0.109	0.008	0.041	215,000.000
8	0.667	0.657	0.211	0.160	0.009	0.042	344,000.000
7.1	0.741	0.736	0.260	0.208	0.010	0.043	472,000.000
6.5	0.825	0.800	0.350	0.296	0.012	0.043	644,000.000
6.3	0.876	0.837	0.544	0.488	0.013	0.043	765,300.000

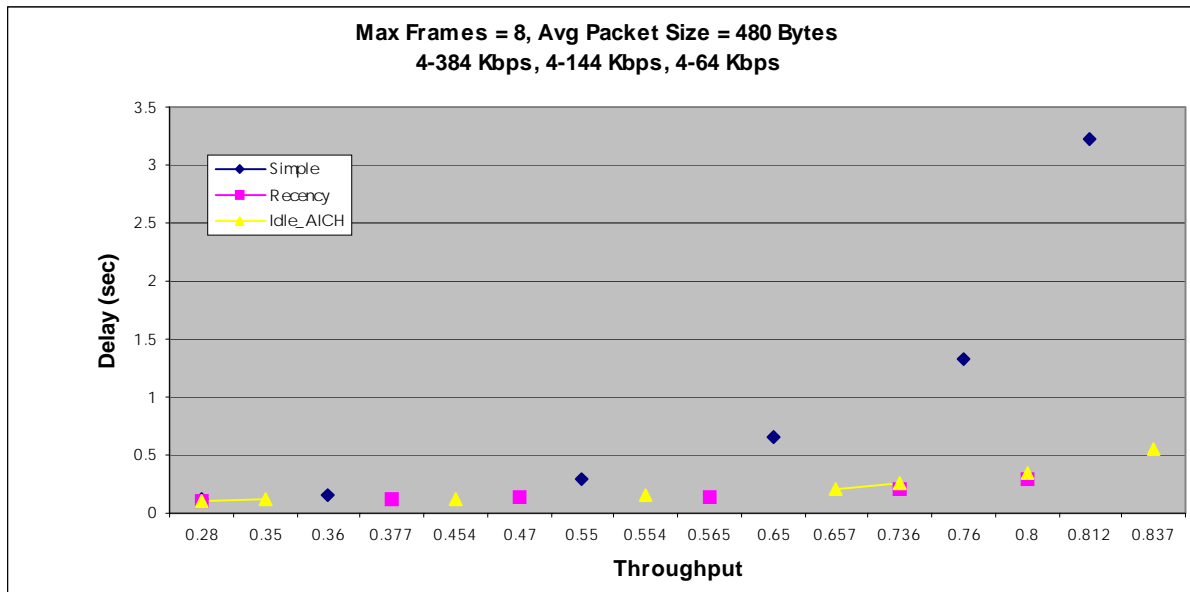

Figure G-2: Delay vs. Throughput

G.3.3 Cases E-F: Impact of packet inter-arrival time

Increasing the packet inter-arrival time from 100 to 200 ms, the throughput delay performance improves significantly. Increasing the packet inter-arrival time, the packet model resembles the Poisson arrival model more. The motivation to increase the packet inter-arrival time to improve the overall delay performance of all methods. This can be achieved in practice by having the TFCI and being able to send more packets during a single CPCH transmission if it arrives in the RLC buffer. This is quite possible from a single logical channel. Both Table 19.6 and Table 19.7 provide results for:

Idle Random Algorithm.

Average packet size 480.

16 CPCH channels: 4 – 384 CPCH; 4 – 144 CPCH; 4 – 64 CPCH.

Case E (Table G-6) corresponds to packet inter-arrival time of 100 ms presented in the previous section (Table G-5) which is repeated here for convenience. Table G-7 addresses the case of 200 ms packet arrival time.

Table G-6: E-mail_1_with idle random algorithm

Sess	ρ	S1	D(un)	QD	AD	TD	MAC Collision
20	0.282	0.280	0.102	0.056	0.007	0.039	65,100.000
16	0.351	0.350	0.118	0.072	0.007	0.039	89,000.000
12	0.458	0.454	0.124	0.076	0.008	0.040	137,500.000
10	0.558	0.554	0.148	0.109	0.008	0.041	215,000.000
8	0.667	0.657	0.211	0.160	0.009	0.042	344,000.000
7.1	0.741	0.736	0.260	0.208	0.010	0.043	472,000.000
6.5	0.825	0.800	0.350	0.296	0.012	0.043	644,000.000
6.3	0.876	0.837	0.544	0.488	0.013	0.043	765,300.000

Table G-7: E-mail_3_with idle random algorithm

Sess	ρ	S1	D(un)	QD	AD	TD	MAC Collision
20	0.275	0.273	0.067	0.022	0.007	0.038	61,600
16	0.329	0.326	0.074	0.028	0.007	0.039	81,900
10	0.470	0.467	0.076	0.029	0.008	0.040	152,700
8	0.558	0.554	0.079	0.031	0.008	0.041	233,300
7	0.616	0.610	0.091	0.041	0.009	0.042	300,000
6.5	0.656	0.647	0.142	0.091	0.009	0.042	345,300
6.3	0.681	0.673	0.112	0.061	0.009	0.042	388,000
4.95	0.819	0.79	0.178	0.123	0.012	0.043	637,000
4.9	0.867	0.824	0.205	0.148	0.014	0.043	746,700

G.3.4 Case G: Number of mobiles in a cell

There could potentially be hundreds of UEs in parallel session as shown by the table in this case. In third case, there are 930 UEs in parallel session if 25% of the capacity was allocated to Packet Data services. Idle-Random CPCH channel is used. There are 6 CPCH channels @ 384ksp/s which is equivalent to 25% of cell capacity. Table G-8 addresses the case of 200 ms packet inter-arrival time.

Table G-8: Delay vs. Number of UEs @ 25% of cell

Mobiles	ρ	S1	D(un)	QD	AD	TD	MAC Coll
318	.257	.256	.08	.031	.011	.038	55,766
750	.609	.604	.137	.078	.017	.042	300,000
930	.798	.772	.241	.175	.022	.044	595,000

G.3.5 Case H-I: Comparison of recency and idle-random methods for single CPCH

The recency method outperforms the random-idle for a single CPCH case and high inter-arrival time of 200 ms as shown by tables in cases F and G. The reason for this is the non-optimised back-off mechanism for the random-idle case. Table G-9 and Table G-10 compare recency and idle-random methods assuming a single 2 Msps CPCH, 200 ms packet inter-arrival, 480 bytes messages.

Table G-9: Idle-random method

ρ	S1	D(un)	QD	AD	TD	MAC Coll
.56	.535	.23	.171	.0448	.0137	200,833
.768	.684	.97	.883	.0729	.0137	398,000

Table G-10: Recency Table method

ρ	S1	D(un)	QD	AD	TD	MAC Coll
.574	.634	.0927	.057	.022	.0137	153,333
.813	.675	.131	.086	.031	.0136	318,666

G.3.6 Case H and J: Comparison of single CPCH and multiple CPCH, idle-random at 2 Msps

As can be seen from the table the multiple CPCH case performs significantly better than the single CPCH case. Note that the packet length in the multiple CPCH case is 1000 bytes whereas in the single CPCH case it is 480 bytes. This case outperforms the single CPCH channel with the recency method as well (Case I). Table G-11 refers to the idle-random method in case of single 2 Msps CPCH, 200 ms packet inter-arrival, 480 bytes messages; Table G-12 refers to the same methods but considering 4 CPCH @ 2Msps, 300 ms inter-arrival time, 1000 byte messages.

Table G-11: Single CPCH with 200 ms packet inter-arrival

\square	\square S1	D(un)	QD	AD	TD	MAC Coll
.56	.535	.23	.171	.0448	.0137	200,833
.768	.684	.97	.883	.0729	.0137	398,000

Table G-12: Multiple CPCH with 300 ms packet inter arrival

\square	S1	D(un)	QD	AD	TD	MAC Coll
.57	.61	.067	.02	.012	.035	6.35 %
.76	.71	.096	.045	.016	.035	14.6%
.82	.75	.104	.05	.019	.035	18.1%
.88	.76	.171	.115	.021	.035	20%
.93	.8	.242	.184	.023	.035	23%
.975	.81	.367	.28	.025	.035	25%

G.4 Discussion on idle-AICH and use of TFCI

As the packet inter-arrival time decreases, the throughput delay performance of all the CPCH channel selection algorithms degrades. At low packet inter-arrival times, the idle-random method clearly out-performs the recency method. The simple method performs worst in all cases. When the packet-inter-arrival time increases to 100-200 ms, then the recency method performs similar to the idle-random case. Note that at high packet inter-arrival times (very low channel loading), the throughput delay performance of all cases improves significantly. In reality, if we do not have fixed packet length and let the UE transmit the incoming packets from the higher layer midst the CPCH transmission, then the packet inter-arrival times will be higher values. By optimising the random-idle case with appropriate back-off mechanism and incorporating the impact of the discrepancies in the recency table, the random-idle case will perform better at high packet inter-arrival times as well. So, we propose adoption of use of idle-AICH to provide for more knowledge of the CPCH channel usage.

G.5 Recommended RRM Strategies

- Use the idle-AICH channel selection algorithm to improve the performance when the packet inter-arrival time is small.
- Use of TFCI is recommended so that the packet arrival process become less clustered and approach the Poisson statistics. This will ensure better throughput delay performance.

Annex H: Change history

Change history					
TSG-RAN#	Version	CR	Tdoc RAN	New Version	Subject/Comment
RAN_06	-	-	RP-99661	3.0.0	(12/99) Approved at TSG-RAN #6 and placed under Change Control
RAN_07	3.0.0	001	RP-000049	3.1.0	(03/00) PDSCH code usage and signalling
RAN_08	3.1.0	003	RP-000228	3.2.0	(06/00) Stage 2 description for Handover to UTRAN
RAN_09	3.2.0	004	RP-000366	3.3.0	(09/00) Clarification on RRC security and capability information transfer during handover to UTRAN
RAN_09	3.2.0	006	RP-000366	3.3.0	Variable Rate Transmission

History

Document history		
V3.0.0	January 2000	Publication
V3.1.0	March 2000	Publication
V3.2.0	June 2000	Publication
V3.3.0	September 2000	Publication