

# ETSI TR 125 905 V7.2.0 (2008-01)

---

*Technical Report*

**Universal Mobile Telecommunications System (UMTS);  
Feasibility study on improvement of  
the Multimedia Broadcast / Multicast Service (MBMS)  
in UTRAN  
(3GPP TR 25.905 version 7.2.0 Release 7)**

---



---

**Reference**

RTR/TSGR-0225905v720

---

**Keywords**

UMTS

**ETSI**

650 Route des Lucioles  
F-06921 Sophia Antipolis Cedex - FRANCE

---

Tel.: +33 4 92 94 42 00 Fax: +33 4 93 65 47 16

Siret N° 348 623 562 00017 - NAF 742 C  
Association à but non lucratif enregistrée à la  
Sous-Préfecture de Grasse (06) N° 7803/88

---

**Important notice**

---

Individual copies of the present document can be downloaded from:

<http://www.etsi.org>

The present document may be made available in more than one electronic version or in print. In any case of existing or perceived difference in contents between such versions, the reference version is the Portable Document Format (PDF). In case of dispute, the reference shall be the printing on ETSI printers of the PDF version kept on a specific network drive within ETSI Secretariat.

Users of the present document should be aware that the document may be subject to revision or change of status. Information on the current status of this and other ETSI documents is available at

<http://portal.etsi.org/tb/status/status.asp>

If you find errors in the present document, please send your comment to one of the following services:

[http://portal.etsi.org/chaicor/ETSI\\_support.asp](http://portal.etsi.org/chaicor/ETSI_support.asp)

---

**Copyright Notification**

---

No part may be reproduced except as authorized by written permission.  
The copyright and the foregoing restriction extend to reproduction in all media.

© European Telecommunications Standards Institute 2008.  
All rights reserved.

**DECT**<sup>TM</sup>, **PLUGTESTS**<sup>TM</sup>, **UMTS**<sup>TM</sup>, **TIPHON**<sup>TM</sup>, the TIPHON logo and the ETSI logo are Trade Marks of ETSI registered for the benefit of its Members.

**3GPP**<sup>TM</sup> is a Trade Mark of ETSI registered for the benefit of its Members and of the 3GPP Organizational Partners.

---

## Intellectual Property Rights

IPRs essential or potentially essential to the present document may have been declared to ETSI. The information pertaining to these essential IPRs, if any, is publicly available for **ETSI members and non-members**, and can be found in ETSI SR 000 314: *"Intellectual Property Rights (IPRs); Essential, or potentially Essential, IPRs notified to ETSI in respect of ETSI standards"*, which is available from the ETSI Secretariat. Latest updates are available on the ETSI Web server (<http://webapp.etsi.org/IPR/home.asp>).

Pursuant to the ETSI IPR Policy, no investigation, including IPR searches, has been carried out by ETSI. No guarantee can be given as to the existence of other IPRs not referenced in ETSI SR 000 314 (or the updates on the ETSI Web server) which are, or may be, or may become, essential to the present document.

---

## Foreword

This Technical Report (TR) has been produced by ETSI 3rd Generation Partnership Project (3GPP).

The present document may refer to technical specifications or reports using their 3GPP identities, UMTS identities or GSM identities. These should be interpreted as being references to the corresponding ETSI deliverables.

The cross reference between GSM, UMTS, 3GPP and ETSI identities can be found under <http://webapp.etsi.org/key/queryform.asp>.

# Contents

Intellectual Property Rights .....	2
Foreword.....	2
Foreword.....	6
1 Scope .....	7
2 References .....	7
3 Definitions, symbols and abbreviations .....	7
4 Introduction .....	8
5 Outline of proposals .....	8
5.1 Dual receiver UEs .....	8
5.1.1 FDD + WCDMA DL .....	8
5.1.1.1 UE capabilities .....	8
5.1.1.2 Scenario 1: MBMS multicarrier Rel-6 network: .....	9
5.1.1.3 Scenario 2: MBMS multicarrier Rel-6 network + optimisations for Rel-7 dual receiver UEs.....	9
5.1.1.4 Scenario 3: Rel-6 network (single carrier or multicarrier) + separate independent MBMS downlink only frequency for Rel-7 dual receiver UEs (FDD) .....	9
5.1.1.5 Architecture.....	10
5.1.2 FDD + TD-CDMA DL .....	11
5.1.2.1 UE capability requirements for support of MBMS .....	11
5.1.2.2 Backwards compatibility.....	12
5.1.2.3 Simultaneous TDD and FDD operation .....	12
5.1.2.3.1 Dual receiver requirements.....	12
5.1.2.3.2 FDD transmit and TDD receive operation.....	12
5.1.2.4 Scenarios .....	13
5.1.2.4.1 Scenario 1: Non-integrated RAN.....	13
5.1.2.4.2 Scenario 2: Integrated RAN .....	13
5.1.3 LCR TDD + LCR TDD DL .....	13
5.1.3.1 UE capability requirements.....	14
5.1.3.2 Scenarios .....	14
5.1.3.2.1 Scenario 1: TDD + TDD DL .....	14
5.1.3.2.2 Scenario 2: TDD + Multicarrier TDD DL .....	14
5.1.3.2.3 Scenario 3: TDD + (Multicarrier) TDD DL .....	14
5.1.3.3 System architecture .....	15
5.1.3.4 Backwards compatibility.....	15
5.1.3.5 Dual receiver requirements .....	15
5.2 SFN operation for MBMS .....	16
5.2.1 Time multiplexing of MBMS SFN with unicast carrier .....	16
5.2.2 SFN MBMS for auxiliary carrier .....	16
5.2.2.1 Single/Dual Receiver Aspects.....	17
5.2.3 SFN operation with transmission delay offset .....	17
5.3 Chip Combining (1.28 Mcps TDD).....	17
6 Analysis of the proposals .....	18
6.1 Dual receiver UEs .....	18
6.1.1 FDD + WCDMA DL .....	18
6.1.1.1 Scenario 1: MBMS multicarrier Rel-6 network: .....	18
6.1.1.1.1 Impact.....	18
6.1.1.1.2 Analysis of the dual receiver UE behaviour .....	18
6.1.1.1.3 Backwards compatibility .....	18
6.1.1.2 Scenario 2: MBMS multicarrier Rel-6 network + optimisations for Rel-7 dual receiver UEs.....	19
6.1.1.2.1 Impact.....	19
6.1.1.2.2 Analysis of the dual receiver UE behaviour .....	19
6.1.1.2.3 Backwards compatibility .....	19

6.1.1.3	Scenario 3: Rel-6 network (single carrier or multicarrier) + separate independent MBMS downlink only frequency for Rel-7 dual receiver UEs (FDD) .....	19
6.1.1.3.1	Impact.....	19
6.1.1.3.2	Analysis of the dual receiver UE behaviour .....	20
6.1.1.3.3	Backwards compatibility .....	20
6.1.2	FDD + TD-CDMA DL .....	20
6.1.2.1	Scenario 1: Non-integrated RAN .....	20
6.1.2.1.1	Architecture/network implication.....	21
6.1.2.1.2	Functions and procedures .....	22
6.1.2.1.3	Support of service continuity.....	24
6.1.2.1.3.1	Mobility in intra-TDD cells .....	24
6.1.2.1.3.2	Support of service continuity .....	24
6.1.2.1.3.3	Service continuity in pre-Rel.6 FDD UTRAN.....	25
6.1.2.1.3.3	Service continuity in Rel.6 FDD UTRAN .....	25
6.1.2.1.4	Connection state of the UE.....	26
6.1.2.1.5	Specification Impacts .....	26
6.1.2.1.6	Benefits and drawbacks .....	26
6.1.2.2	Scenario 2: Integrated RAN .....	27
6.1.2.2.1	Architecture/network implication.....	28
6.1.2.2.1.1	Integrated RAN based on Rel.6 MBMS framework .....	28
6.1.2.2.1.2	Integrated RAN, using the "one tunnel" approach.....	30
6.1.2.2.2	Functions and procedures .....	32
6.1.2.2.3	Support of service continuity.....	35
6.1.2.2.4	Connection state of the UE.....	36
6.1.2.2.5	Specification Impacts .....	36
6.1.2.2.6	Benefits and drawbacks .....	37
6.1.2a	LCR TDD + LCR TDD DL.....	37
6.1.2a.1	Scenario 1: TDD + TDD DL.....	37
6.1.2a.1.1	Analysis of functions .....	37
6.1.2a.1.2	Specification impacts.....	38
6.1.2a.1.3	Evaluation.....	38
6.1.2a.2	Scenario 2: TDD + Multicarrier TDD DL.....	38
6.1.2a.2.1	Analysis of functions .....	38
6.1.2a.2.2	Specification impacts.....	38
6.1.2a.2.3	Evaluation.....	39
6.1.2a.3	Scenario 3: TDD + Multicarrier TDD DL.....	39
6.1.2a.3.1	Analysis of functions .....	39
6.1.2a.3.2	Specification impacts.....	39
6.1.2a.3.3	Evaluation.....	40
6.1.3	Interference considerations for simultaneous operation of unicast and MBMS auxiliary carrier .....	40
6.1.3.1	Solution 1: Allow a guard band between paired the UL carrier and the unpaired MBMS carrier .....	40
6.1.3.2	Solution 2: Smart scheduling .....	40
6.1.3.3	Solution 3: GSM fallback for MBMS dedicated frequency .....	40
6.1.4	RF Aspects of Re-configuration of Rx diversity terminal to support two independent frequency layers.....	41
6.2	SFN operation for MBMS .....	41
6.2.1	TD-CDMA - Time multiplexing of MBMS with unicast carrier.....	41
6.2.1A	1.28 Mcps TDD - Time multiplexing of MBMS with unicast carrier .....	42
6.2.2	TD-CDMA - MBMS for auxiliary carrier .....	42
6.2.2A	1.28 Mcps TDD - MBMS for dedicated carrier.....	43
6.2.3	MBMS dedicated carrier with SFN operations – Study 1 (FDD).....	43
6.2.3.1	Simulation assumptions and physical channel conditions.....	43
6.2.3.2	Spectral efficiency.....	44
6.2.4	MBMS dedicated carrier with SFN operations – Study 2 (FDD).....	44
6.2.4.1	Simulation assumptions and physical channel conditions.....	44
6.2.4.2	Spectral efficiency.....	45
7	Conclusions and Recommendations.....	46
7.1	Conclusions.....	46
7.1.1	Dual receiver UEs.....	46
7.1.2	Network architecture considerations for separate MBMS carrier.....	46
7.1.3	SFN operation for MBMS .....	46

**Annex A: Change history .....48**  
History .....49

---

# Foreword

This Technical Report (TR) has been produced by ETSI 3rd Generation Partnership Project (3GPP).

The present document may refer to technical specifications or reports using their 3GPP identities, UMTS identities or GSM identities. These should be interpreted as being references to the corresponding ETSI deliverables.

The cross reference between GSM, UMTS, 3GPP and ETSI identities can be found under <http://webapp.etsi.org/key/queryform.asp>.

The contents of the present document are subject to continuing work within the TSG and may change following formal TSG approval. Should the TSG modify the contents of the present document, it will be re-released by the TSG with an identifying change of release date and an increase in version number as follows:

Version x.y.z

where:

- x the first digit:
  - 1 presented to TSG for information;
  - 2 presented to TSG for approval;
  - 3 or greater indicates TSG approved document under change control.
- y the second digit is incremented for all changes of substance, i.e. technical enhancements, corrections, updates, etc.
- z the third digit is incremented when editorial only changes have been incorporated in the document.

---

# 1 Scope

The present document summarizes the work done under the study item "Improvement of the Multimedia Broadcast Multicast Service (MBMS) in UTRAN" defined in [1] by listing technical concepts addressing the objectives of the study item, analysing these technical concepts and recommending a way forward of the study item.

---

# 2 References

The following documents contain provisions which, through reference in this text, constitute provisions of the present document.

- References are either specific (identified by date of publication, edition number, version number, etc.) or non-specific.
- For a specific reference, subsequent revisions do not apply.
- For a non-specific reference, the latest version applies. In the case of a reference to a 3GPP document (including a GSM document), a non-specific reference implicitly refers to the latest version of that document *in the same Release as the present document*.

- [1] 3GPP TD RP-050746: "Proposed Study Item on Improvement of the Multimedia Broadcast Multicast Service (MBMS) in UTRAN".
- [2] MBMS User Service Extensions WI description, <http://www.3gpp.org/specs/WorkItem-info/WI--34038.htm>
- [3] Packet Switched Streaming Enhancements (PSSe) WI, [http://www.3gpp.org/ftp/tsg\\_sa/TSG\\_SA/TSGS\\_32/docs/SP-060361.zip](http://www.3gpp.org/ftp/tsg_sa/TSG_SA/TSGS_32/docs/SP-060361.zip)
- [4] 3GPP TR 25.803 v6.0.0 – "S-CCPCH Performance for MBMS"
- [5] 3GPP TS 25.346: "Introduction of the Multimedia Broadcast/Multicast Service (MBMS) in the Radio Access Network (RAN); Stage 2".

---

# 3 Definitions, symbols and abbreviations

## 3.1 Definitions

For the purposes of the present document, the following terms and definitions apply.

<defined term>: <definition>.

## 3.2 Symbols

For the purposes of the present document, the following symbols apply:

<symbol> <Explanation>

## 3.3 Abbreviations

For the purposes of the present document, the following abbreviations apply:

UMTS	Universal Mobile Telecommunications System
UTRAN	UMTS Terrestrial Radio Access Network
MBMS	Multimedia Broadcast Multicast Service



MCCH	MBMS point-to-multipoint Control Channel
MICH	MBMS notification Indicator Channel
MTCH	MBMS point-to-multipoint Traffic Channel
SFN	Single Frequency Network

---

## 4 Introduction

The objective of this study item [1] is to analyse the feasibility and merits of potential improvement of MBMS in the Release 7 RAN specifications. It is the intention that the introduction of MBMS based on Release 6 due to these enhancements should not be delayed, and that these improvements should be able to be integrated on top of the Rel6 functionalities smoothly. The study should progress based on the current framework of Release 6 MBMS in backward compatible ways.

The potential improvements of MBMS described in this technical report are as follows:

- Support for a dual receiver UE receiving simultaneously MBMS and dedicated services on separate carriers.
- SFN operation of MBMS in the physical layer

---

## 5 Outline of proposals

### 5.1 Dual receiver UEs

#### 5.1.1 FDD + WCDMA DL

Since MBMS is intended to serve a large user population, the usage of radio resources must be managed efficiently to avoid system overload due to MBMS services which could degrade the quality of the unicast services. With the use of dual receiver UE, the overload traffic condition can be reduced by delivering the MBMS traffic over a separate frequency band from that used for unicast services.

Thereby the impact between dedicated and MBMS traffic can be minimized, and the available data rates for MBMS can be maximized.

Even though the UE with dual receiver capability enables the reception of MBMS services on a separate frequency band, it is not yet clear how MBMS services can be delivered over a separate frequency band in the current MBMS infrastructure. One possible way of achieving this is the use of overlay FDD networks for delivery of MBMS services. This allows UMTS operators to offer subscribers MBMS services without impacting other voice and data services. The additional functional and infrastructure requirements imposed by MBMS via overlay spectrum is analyzed based on the current Rel.6 MBMS framework.

##### 5.1.1.1 UE capabilities

A dual receiver UE for the study in the scope of this SI should be capable of simultaneously receiving dedicated services and MBMS PtP / PtM services on one frequency A plus MBMS services sent on PtM bearers on a separate frequency B e.g.:

- Frequency A (FDD, dedicated services + MBMS, frequency on which the UE is camping for reception of dedicated services):
  - Channels necessary independent from MBMS
  - MICH or MCCH (FFS) independently from the MBMS services on frequency B
  - MTCH, (FFS) depending on the reception of MBMS services on frequency B with the dual receiver
- Frequency B (FDD) (additional MBMS capabilities):
  - BCCH

- MICH or MCCH (FFS) independently from the reception of MBMS services or dedicated services on frequency A
- MTCH with the dual receiver, possibly depending on the reception of MBMS services on the frequency A

Detailed capabilities depend on the scenario and are FFS.

Dual receiver UEs can be useful for different scenarios as outlined below:

### 5.1.1.2 Scenario 1: MBMS multicarrier Rel-6 network:

In this scenario an operator has deployed a multicarrier network with more than one 5MHz frequency. In order to allow to build UEs with a dual receiver several issues in the Rel-6 specification need to be clarified as listed below:

- Rel-6 frequency convergence and counting used to allow the network to transmit MBMS in only one frequency
- Rel-7 rules for dual receiver UEs without network impact allow to receive dedicated and MBMS services in certain scenarios

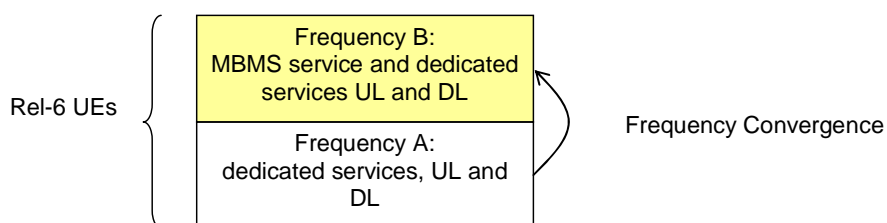
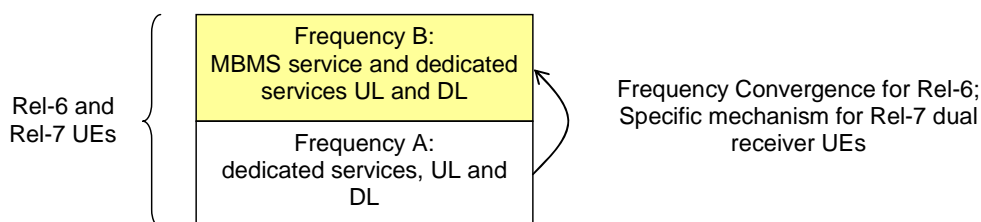

**Figure 1: MBMS multicarrier network in Rel6 with Rel-7 dual receiver UEs**

### 5.1.1.3 Scenario 2: MBMS multicarrier Rel-6 network + optimisations for Rel-7 dual receiver UEs

In order to optimize the usage of the capabilities of a dual receiver UE some specific optimizations are beneficial.

- Rel-6 frequency convergence and counting used for transmission in only one frequency
- Rel-7 rules for dual receiver UEs without network impact allow to receive dedicated and MBMS services with no restriction
- Rel-7 mechanisms for dual receiver UEs allow resource optimization to receive dedicated and MBMS services with no restriction

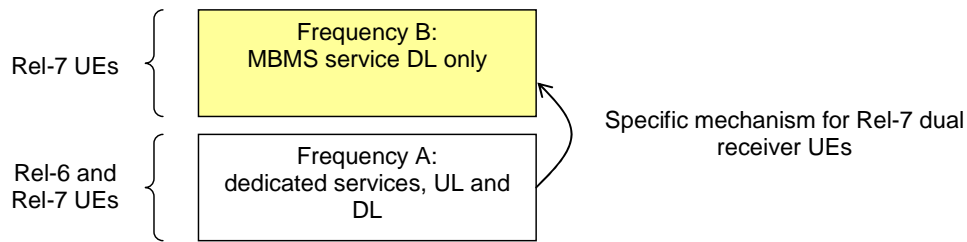

**Figure 2: MBMS multicarrier Rel-6 network + optimisations for Rel-7 dual receiver UEs**

### 5.1.1.4 Scenario 3: Rel-6 network (single carrier or multicarrier) + separate independent MBMS downlink only frequency for Rel-7 dual receiver UEs (FDD)

In order to optimize the usage of the capabilities of a dual receiver UE some specific optimizations are beneficial.

- Mechanisms for paging on the Rel 6 network which allows to activate the dual receiver for reception of MBMS services



**Figure 3: Rel-6 network (single carrier or multicarrier) + separate independent MBMS downlink only frequency for Rel-7 dual receiver UEs (FDD)**

5.1.1.5 Architecture

Different architectures can be imagined, depending on the level of integration of the overlay network together.

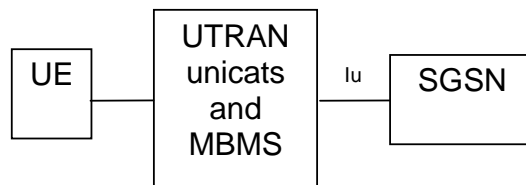

**Figure 4: Network infrastructure of overlay MBMS with support of counting/PtP establishment**

Figure 5 shows a scenario where the overlay network is managed by dedicated equipment and counting and PTP establishment are coordinated via the Iur interface.

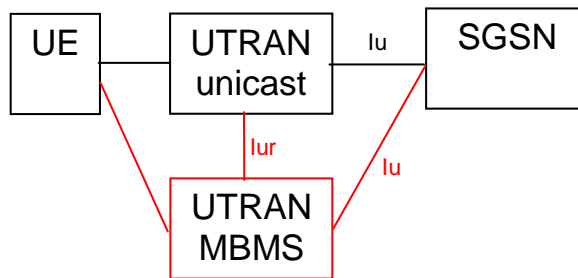

**Figure 5: Network infrastructure of overlay MBMS with coordinated support of counting/PtP establishment on Iur**

Figure 6 shows a scenario where the overlay network is managed by dedicated equipment, reducing the impact on the the UTRAN handling unicast services.

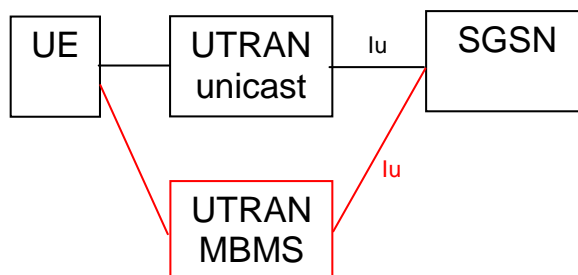

**Figure 6: Network infrastructure of overlay MBMS without support of counting**

The choice of the architecture might not impact standards, and thus be an implementation choice.

### 5.1.2 FDD + TD-CDMA DL

Most 3G operators have at least one or more markets that have both paired spectrum and unpaired spectrum. By its very nature, FDD is well matched to symmetrical services and hence paired spectrum, whereas TDD is well matched to either symmetrical or asymmetrical services and hence unpaired spectrum. Given the high degree of asymmetry in MBMS traffic, a solution that utilises both paired and unpaired spectrum in an efficient manner can help maximise an operators spectrum assets for delivery of MBMS services. The purpose of this part of the study is to investigate the use of TDD as an overlay network to FDD network for delivery of MBMS services. This not only allows UMTS operators to offer to their subscribers MBMS services without impacting other voice and data services, but also provides to the operators an attractive way to fully utilise their existing unpaired spectrum.

For the case when unpaired/TDD spectrum is dedicated to MBMS, all time slots in a radio frame are assigned as DL. However, if, it is deemed necessary that only a portion of the unpaired/TDD spectrum is to be allocated to MBMS, then through time slicing, the remaining non-MBMS slots can be assigned to other services (non-MBMS) in the radio frame (see Figure 7). This provides a flexible operation scenario, thus providing a spectrum management according to the application demand.

The UE which is capable of simultaneous reception of non-MBMS services over FDD and MBMS service over TDD downlink carrier is referred to as "FDD with Downlink Only TDD (FDOT)" in this document.

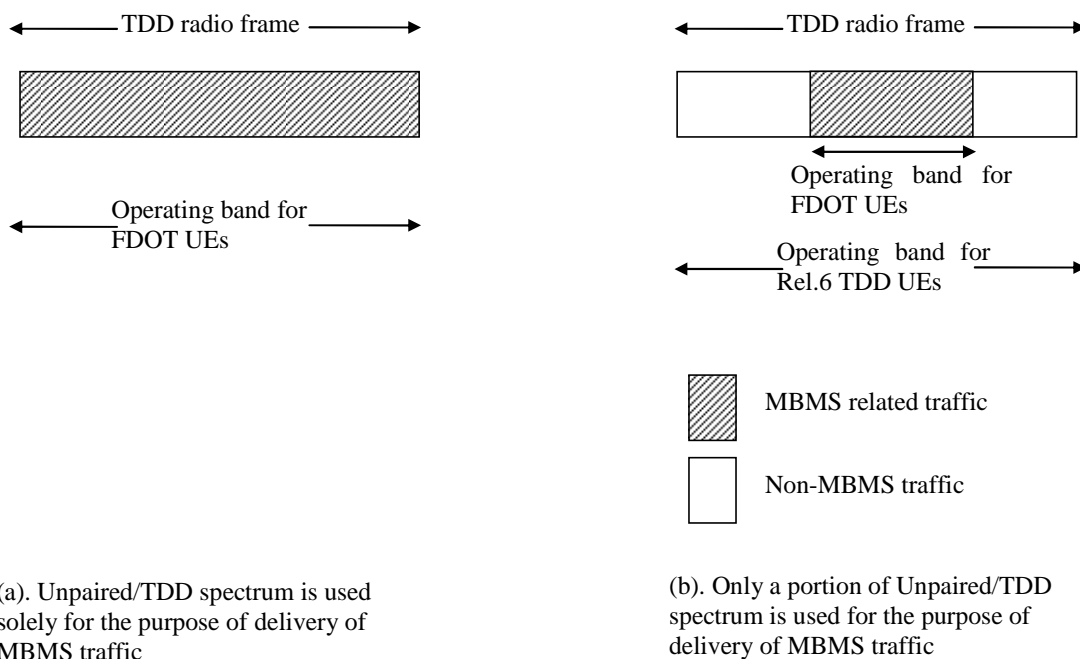

**Figure 7: Delivery of MBMS over unpaired/TDD spectrum**

MBMS over unpaired/TDD spectrum allows UMTS operators to offer to their subscribers MBMS services without impacting the performance of their other services, particularly those which are provided over paired spectrum. The additional functional and infrastructure requirements imposed by MBMS via overlay spectrum are analyzed based on the current Rel.6 MBMS framework.

#### 5.1.2.1 UE capability requirements for support of MBMS

Unpaired/TDD spectrum is used for the transmission of MBMS traffic and MBMS traffic related control information in downlink. All uplink communication could be carried over FDD spectrum. Thus, the minimum UE capability requirement for MBMS over unpaired/TDD spectrum is TDD/FDD dual receiver and FDD transmitter at the UE. We refer to this UE as an FDD with Downlink Only TDD (FDOT). The difference between an FDOT UE and a Rel.6 TDD UE in terms of receiving MBMS traffic on a TDD carrier is shown in Figure 7.

For the FDOT UE, the necessary control signalling for MBMS service announcement, service activation, user joining/leaving, counting and other control signalling will be carried over FDD spectrum. This enables network operators the use of existing control functionalities ensuring backwards compatibility with the Rel.6 MBMS framework. Table 1 summaries the MBMS functional split between FDD and TDD carriers in an overlay MBMS network.

**Table 1: The MBMS functional split between FDD and TDD carriers in an overlay MBMS network.**

Function	FDD	TDD
Service announcement	X	
Service activation/joining	X	
Delivery of MICH: MBMS notification		X
Delivery of MCCH: session starts/stop indication, etc		X
Delivery of MTCH		X
Delivery of MSCH		X
Delivery of DTCH (MBMS p-t-p bearer)	X	
User leaving	X	
Uplink communication (counting response, cell update, URA update, etc)	X	

### 5.1.2.2 Backwards compatibility

The network architecture for supporting an FDOT UE ensures backwards compatibility for both Rel.6 FDD and TDD UEs. For the FDOT UE, the MBMS control information is transmitted over the FDD spectrum and using the MBMS service announcement an indication of those MBMS services provided over TDD spectrum is signalled. Therefore, FDD UEs that are camped onto the FDD system are unaffected by the introduction of MBMS over TDD spectrum. The FDOT UEs with TDD/FDD dual receiver capability can camp onto the FDD system and receive MBMS service over TDD spectrum.

In order to guarantee backwards compatibility for Rel.6 (and earlier) TDD capable UEs, the non-MBMS services are made available over a portion of the TDD spectrum, effectively time slicing the TDD carrier as shown in Figure 7(b). Thus, the Rel.6 TDD UEs can camp onto the TDD system and operate normally.

### 5.1.2.3 Simultaneous TDD and FDD operation

The FDOT UE requires simultaneous operation of TDD RX and FDD TX/RX. The impact of supporting FDD and TDD in the same device and operating both technologies simultaneously needs to be considered.

#### 5.1.2.3.1 Dual receiver requirements

Simultaneous operation of TDD and FDD in the same device requires a dual receiver. The TDD receiver in the FDOT UE is used for MBMS services transmitted over unpaired spectrum and the FDD receiver is used for MBMS and non-MBMS traffic transmitted over FDD spectrum. There may be some possibility of hardware reuse in the same device between the two technologies although it should be borne in mind that simultaneous operation of TDD and FDD is required, which may necessitate some duplication of receiver functionality.

#### 5.1.2.3.2 FDD transmit and TDD receive operation

MBMS services transmitted over TDD spectrum are required to operate in the same device and at the same time as FDD. From an RF perspective, the impact of uplink FDD transmissions internal to the device should have minimal impact on the quality of downlink TDD reception which is also internal to the same device. These issues are under the remit of RAN4 and would need to be investigated.

Having MBMS services transmitted over TDD spectrum with all uplink communication via FDD spectrum simplifies the device substantially since the TDD portion of the device does not require a transmitter. This means the device consists of one transmitter and two receivers. Moreover, this also means there are no impacts on FDD receive from TDD transmit.

#### 5.1.2.4 Scenarios

For support of the FDOT UE we consider the level of interaction required between the TDD and FDD networks. Two different deployment scenarios are selected for further investigation. Both scenarios are fully analysed in clause 6 with respect to:

- architecture/network implication;
- functions and procedures;
- support of service continuity;
- connection state of the UE;
- specification impacts; and
- benefits and drawbacks.

##### 5.1.2.4.1 Scenario 1: Non-integrated RAN

In this scenario, MBMS services are supported over TDD using p-t-m. The MBMS service is broadcast over the entire service area using TDD MBMS bearers regardless of the number of users that have activated the service in the service area. The control information with respect to the higher layer MBMS service announcement and service activation are communicated over FDD. While in the TDD coverage area, the FDOT UE can receive the MBMS services. As such, no interaction between TDD and FDD networks is required at the RAN level and no counting procedure is required.

The non-integrated RAN architecture for MBMS over TDD spectrum is designed to ensure backwards compatibility for Rel.6 TDD UEs and FDD UEs (agnostic of the release).

This deployment scenario well suits the provision of MBMS broadcast applications such as mobile TV, where the same application content is broadcast at a given time everywhere in the network.

##### 5.1.2.4.2 Scenario 2: Integrated RAN

In this scenario, MBMS services are supported over TDD using p-t-m. The MBMS service is made available over TDD cells only if the number of users, who have activated the service in the cell, is larger than a pre-defined threshold. Otherwise, the MBMS service is provided to the activated users using point-to-point connection over FDD carriers. Note that the pre-defined threshold value may be one indicating at least one user has activated the MBMS service in the cell. This avoids the transmission of MBMS traffic in an empty cell.

The non-integrated RAN architecture for MBMS over TDD spectrum is designed to ensure backwards compatibility for both Rel.6 TDD and FDD UEs.

This deployment scenario requires interaction between TDD and FDD networks at the RAN level. This scenario not only provides MBMS service continuity at the edge of TDD coverage it also provides a better radio resource utilization and efficient spectrum management according to service demand in TDD spectrum.

#### 5.1.3 LCR TDD + LCR TDD DL

The study in this section applies only to 1.28 Mcps TDD.

For the time being it would be envisaged that the operators will provide over UMTS network the MBMS services, which may require fairly high data transmission rate. For TDD mode in UMTS, the bandwidth of a single carrier is much narrower than that of FDD mode, therefore there would be some cases where the provided MBMS services can occupy the whole radio resources of a cell. In those cases separating one carrier to operate in downlink only for the transmission of MBMS services will intuitively lead to a number of benefits. The purpose of this part of the study is to investigate the use of TDD downlink only as an overlay network to Rel-6 TDD network for delivery of MBMS services. The deployment scheme of this study is to allow operators to be able to deploy MBMS function without impacting other voice and data services.

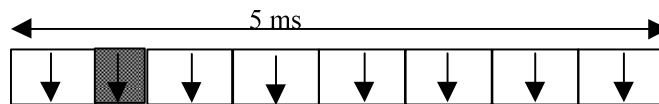

**Figure 7a: Delivery of MBMS over dedicated DL carrier**

In case a TDD spectrum is dedicated to MBMS services as stated, all time slots in a radio subframe should be assigned as DL (as seen in Figure 7a) It is expected that the spectrum efficiency could be remarkably improved provided that a special subframe structure is designed for TDD DL due to the fact that the current TDD subframe structure serves to cater for the transmission requirements for both downlink and uplink.

Within the special TDD subframe, there may be modification in the slot structures in comparison with Rel-6 TDD time slots. Further the special slots embedded in the traditional LCR TDD could be combined and appear as a short time slot for the delivery of System Information and MBMS control signalling. Therefore all the timeslots should fully be assigned to the delivery of MBMS services and correlative signalings.

### 5.1.3.1 UE capability requirements

It is anticipated that the Rel-7 TDD DL carrier should be only used for transmission of MBMS traffic and its associated control information in downlink. All uplink transmission would take place in the Rel-6 TDD network. Therefore the UE minimum capability is dual receiver for Rel-6 TDD/ Rel-7 TDD DL and single Rel-6 TDD transmitter in that there is a requirement for simultaneous reception for information provided by Rel-6 TDD/ Rel-7 TDD DL.

### 5.1.3.2 Scenarios

#### 5.1.3.2.1 Scenario 1: TDD + TDD DL

In this scenario, TDD operators deploy a Rel-7 MBMS DL network with a standalone frequency band on the basis of a Rel-6 TDD network with the following configurations:

- Rel-6 TDD network: traditional services + MBMS, with generic channel configurations as for Rel-6 TDD network
- Rel-7 TDD DL network: additional MBMS provision, configured only with BCCH, MICH, MCCH, MSCH and MTCH

#### 5.1.3.2.2 Scenario 2: TDD + Multicarrier TDD DL

In this scenario, TDD operators deploy a multicarrier MBMS DL network within a standalone frequency band on the basis of a Rel-6 TDD network. The introduced multicarrier MBMS DL network utilizes a carrier cluster, two or more basic carriers with a bandwidth of 1.6MHz for each.

The following configurations apply to this scenario:

- Rel-6 TDD network: traditional services + MBMS, with generic channel configurations as for Rel-6 TDD network
- Rel-7 Multicarrier TDD DL network: additional MBMS provision, configured with BCCH, MICH, MCCH, MSCH and MTCH in its preferred carrier and with MTCH in its secondary carriers

#### 5.1.3.2.3 Scenario 3: TDD + (Multicarrier) TDD DL

In this scenario, TDD operators deploy a single carrier (or multicarrier) MBMS DL network within a standalone frequency band based upon a Rel-6 TDD network. The Rel-6 TDD network broadcasts the system information and control message relevant to the MBMS services carried onto the introduced MBMS DL network.

The following configurations apply to this scenario:

- Rel-6 Mixed TDD network: traditional services + MBMS, with generic channel configurations as for Rel-6 TDD network, additionally carrying controlling information for additional MBMS services to be transmitted over Rel-7 Multicarrier TDD DL network

- Rel-7 (Multicarrier) TDD DL network: additional MBMS provision, configured with only MTCH

### 5.1.3.3 System architecture

This part of the document investigates a system architecture (as seen in Figure 7b) taking account of the scenarios in subclause 5.1.3.2. In the system architecture, the same Rel-6 TDD RNC can be reused for supporting delivery of MBMS services over TDD DL with enhancement in terms of e.g. coordination between dedicated services via Rel-6 TDD network and MBMS services over TDD DL. In this sense, that RNC is an integrated Rel-7 TDD RNC based upon Rel-6 TDD RNC.

The essence of integration in Rel-7 TDD RNC provides possibility for it to flexibly assign resources of two networks with high efficiency from the perspective of Radio Resource Management, which is implementation dependent. Whether counting or not is up to the choice of Rel-7 TDD RNC according to the type of application.

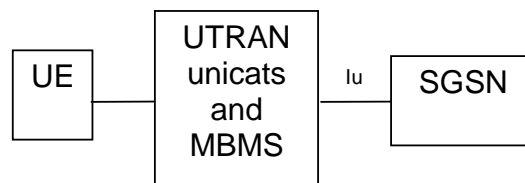

**Figure 7b: System architecture for overlay MBMS over dedicated DL carrier**

In some cases the MBMS service, which is subject to the control of Rel-6 TDD, can be made available over Rel-7 TDD DL cells given that the service is suited to broadcast, or the number of users, who have activated the service in the overlay area, is larger than a pre-defined threshold. Otherwise, the MBMS service is provided to the activated users using PTP or PTM connection over Rel-6 TDD carriers.

In order to receive an MBMS service over Rel-7 TDD DL, UE can be in RRC Idle mode with regard to the Rel-7 TDD DL cell, which means that there is no impact on UE's connection state against Rel-6 TDD cell.

There is no requirement of mobility for UE with respect to Rel-7 TDD DL. The UE mobility between Rel-6 TDD cells respects the same procedures as defined in Rel-6 specifications. If the UE moves between Rel-7 TDD DL cells which belong to the same MBMS cell group, it is not needed to re-establish an RLC entity and re-initialise PDCP entity between the UE and the related Rel-7 TDD RNC for the services received. However, if the cells belong to different MBMS cell groups, the UE is required to re-establish the RLC entities and re-initialise the PDCP entities.

### 5.1.3.4 Backwards compatibility

The system architecture described in section 5.1.3.3 would make sure that it is backward compatible for UEs working in Rel-6 TDD mode. For Rel-7 TDD DL network there is limited system information broadcast in BCCH compared to Rel-6 TDD network, which could force mischoosing Rel-6 TDD UEs to give up camping on that. There is no impact to Rel-6 TDD UEs camped on Rel-6 TDD network after introduction of Rel-7 TDD DL network. In scenario 3 the backwards compatibility would be ensured by the means of consolidated classification of MCCH control signalling among Rel-6 TDD network and Rel-7 TDD DL network, where Rel-6 UEs could automatically omit the parsing of the information element applicable only to Rel-7 UEs. While the details and its potential complexity resulted should need further investigation.

### 5.1.3.5 Dual receiver requirements

Simultaneous reception of Rel-6 TDD/ Rel-7 TDD DL in the same device requires a dual receiver. The Rel-7 TDD DL receiver in the UE is used only for MBMS services transmitted over standalone spectrum and the Rel-6 TDD receiver is used for MBMS and non-MBMS traffic. There may be possibility for certain hardware implementation where only one receiver would be used to receive from both Rel-6 TDD and Rel-7 TDD DL in time multiplexing mode at the sacrifice of higher signal interruption between two bands.

MBMS services transmitted over Rel-7 TDD DL spectrum are required to operate in the same device and at the same time as Rel-6 TDD. From an RF perspective, the impact of uplink Rel-6 TDD transmissions internal to the device should have minimal impact on the quality of downlink Rel-7 TDD DL reception which is also internal to the same device. This may require stringent isolation of frequency band in between Rel-6 TDD and Rel-7 TDD DL, which is under the remit of RAN4 and would need to be investigated.



## 5.2 SFN operation for MBMS

It has been identified in RAN WG1 that the use of a common cell ID, facilitating a so-called single-frequency network (SFN), leads to significant improvements over release 6 MBMS spectral efficiency. In this transmission method, identical and closely time-synchronised signals are transmitted from multiple cells. Delayed versions of the signal are observed at the receiver due to the multi-cell transmission. These may be treated as multipath components and can be combined in the receiver in a similar fashion to existing UTRA receivers. By doing so, intercell interference is transformed into useful signal energy and the distribution of C/I across the coverage area is improved. This in turn leads to higher possible data rates for MBMS and higher spectral efficiencies. In some situations the C/I improvements can be such that the system becomes code (rather than interference) limited. As such, higher order modulations (e.g. 16-QAM) become applicable for MTCH transmission. Design considerations of relevance to an SFN physical layer architecture are:

- Configuration of a common scrambling code,
- Base site synchronisation,
- Receiver support for sufficient delay spread (of the order of 33 $\mu$ s),
- Support for UE discontinuous reception (DRX),
- Receiver support for suitable equaliser technology,
- Backwards compatibility with the existing UTRA physical layer architectures in existing spectral assignments,
- Flexibility of resource partitioning between unicast and MBMS SFN transmissions;
- Support for higher order modulation schemes on S-CCPCH,
- Minimisation of required signalling,
- Support for UE receive diversity,
- Support for mobility.

Two possibilities have been discussed for multiplexing of SFN transmissions with non-SFN transmissions. These are time division multiplexing (same carrier) and frequency division multiplexing (separate carriers) as discussed in subclauses 5.2.1 and 5.2.2 respectively.

It has been identified that under certain deployment scenarios, SFN performance may sometimes be improved via the creation of phase offsets or delay offsets between cells participating in an SFN transmission. Application of these techniques is considered to be a Node-B implementation issue.

### 5.2.1 Time multiplexing of MBMS SFN with unicast carrier

With a TDD air-interface, due to the self-contained time-slotted nature of the transmission, it is possible to time multiplex SFN MBMS transmissions with existing non-SFN (e.g. unicast) transmissions on a single carrier. With this approach, non-SFN timeslots would employ a cell-specific cell ID (i.e. scrambling code and midamble base code) whilst SFN MBMS timeslots would employ a common cell ID (an identical scrambling code and midamble base code are utilised across multiple cells).

The spectral efficiency of the MBMS transmissions can therefore be improved via common cell ID transmission without the need for a dedicated carrier. Timeslots reserved for existing MTCH transmission methods in Release 6 may be replaced or augmented by SFN timeslot transmissions. It is possible to alter the portion of time resources assigned to unicast and SFN broadcast/multicast services.

### 5.2.2 SFN MBMS for auxiliary carrier

In this approach, SFN MBMS transmissions are provided on a separate carrier to non-SFN (e.g. unicast) transmissions. The SFN auxiliary carrier would employ a common cell ID (scrambling code) whilst the non-SFN carrier would employ a cell-specific cell ID. This configuration applies to both TDD and FDD air-interface methods.

### 5.2.2.1 Single/Dual Receiver Aspects

The UE may be able to support reception of SFN MBMS services in parallel with other (e.g. unicast) services. In addition, the UE is required to perform normal background operations in support of mobility. When SFN MBMS transmission is performed on a separate carrier to the unicast services, the reception capability of the terminal needs to be considered.

If the receiver is capable of reception on only a single carrier this leads to a requirement that e.g. reception of the unicast and SFN MBMS services are multiplexed in time or the unicast and multicast service are provided for such UEs on the unicast carrier. If the receiver is capable of simultaneous reception of two separate carriers, the unicast and SFN MBMS services for that UE do not need to be time multiplexed.

### 5.2.3 SFN operation with transmission delay offset

In some scenarios, multi-path components from strongest neighbouring cells may overlap with each other due to insufficient spatial separation. In such cases, and when SFN transmission is deployed, a gain arises only from power enhancement by multiple signal replica overlapping rather than that in MRC fashion.

In order to promote SFN operation performance in these deployments, additional diversity may be provided by applying different delays to base stations participating in an SFN transmission. By means of introducing an artificial delay in SFN MBMS transmission, multiple components from serving and neighbouring cells are better discriminated and thus utilised.

## 5.3 Chip Combining (1.28 Mcps TDD)

Chip Combining is a technique that bears some relation to Space Code Transmit Diversity (SCTD) in existing releases except that the combining is performed between cells with different scrambling codes instead of between transmit antennas of the same cell with the same scrambling code.

Chip Combining has been proposed as another form of combining method for p-t-m transmissions for 1.28 Mcps TDD mode. All involved cells still keep their own configuration of scrambling code (i.e. different cells participating in the p-t-m transmission have different scrambling codes on the MBMS timeslots). As for SFN transmission, in Chip Combining mode, all Node Bs involved are closely time synchronized, which is an inherent characteristic of TDD systems.

The UE interested in one p-t-m MBMS service gets the active configuration, such as the midamble codes and the scrambling codes used in the current cell and in the involved neighbouring cells from BCCH and/or MCCH. The UE must monitor the signal strengths of the involved cells and must select a number of cells to combine. In an active p-t-m timeslot, the UE performs channel estimation of each cell to be combined and gets the system matrixes of each involved cell respectively, and then, one compound system matrix can be formed by combining the system matrix of these involved cells. After that, the UE uses joint detection algorithm to recover the MBMS data with the compound system matrix.

Chip Combining brings no change and requirement to network equipment. However, in order to approach the performance offered by SFN, a relatively large number of cells must be detected and efficiently combined by the UE. Alternatively, chip combining could be used for small service areas (only a small number of cells participate in a simulcast transmission). In this case the number of cells which must be combined by the UE can be reduced and the performance loss compared to SFN is then lowered.

A UE should have a minimum capability to detect and combine a certain number of cells so that performance of the MBMS p-t-m (and hence coverage of the MBMS service) can be guaranteed. The complexity of the UE and the performance of the chip combining method would have some bearing on the choice of this minimum number of cells that must be combined by the UE.

---

## 6 Analysis of the proposals

### 6.1 Dual receiver UEs

#### 6.1.1 FDD + WCDMA DL

##### 6.1.1.1 Scenario 1: MBMS multicarrier Rel-6 network:

###### 6.1.1.1.1 Impact

The following points need clarification in the standards and are proposed to be addressed during a work item phase:

- Counting  
Since according to the proposed UE capabilities there is a capability for uplink transmission only on one frequency, and in order not to impact the behaviour of the network the UE is only allowed to respond to counting on the uplink frequency corresponding to the frequency where counting is indicated in the MCCH, thus the UE should not respond the counting initiated on frequencies that are received using the dual receiver capabilities.
- PtP establishment  
Today when the UE initiates a RRC Connection setup / Cell Update message in order to respond to PtP bearer establishment request there is no indication of the related services. Therefore a network in Rel-6 should never expect a request for a MBMS PtP bearer on which it has not initiated a PtP bearer establishment. Therefore a dual receiver UE should today only respond to the PtP bearer establishment indication on the corresponding uplink frequency where PtP bearer establishment is indicated in the MCCH
- Frequency convergence
  - Idle / Cell/URA\_PCH / CELL\_FACH state procedure  
Frequency convergence is today performed in order to allow that UEs that are camping on a frequency on which a MBMS service is not broadcast to select to the frequency on which the service is broadcast. A dual receiver UE as defined above does in principle not need to follow the frequency convergence. However the network could perform counting, re-counting, or switch to PtP bearer at any time. In those cases the UE should answer always on the frequency corresponding to the frequency on which it as received the indication for counting / PtP establishment.
  - CELL\_DCH procedure  
According to the Rel-6 specifications the UE should indicate to the network if its preferred frequency is different from the frequency that is currently used for dedicated services. However for a dual receiver UE, even if the prioritized service is sent on a different frequency on a PtM bearer there is no real problem for this UE, and indicating to the network the wish to change frequency would have more drawbacks than advantages.
- MBMS cell selection:  
In the case that a Rel-6 UE is performing frequency convergence it will follow the Rel-6 inter frequency cell selection rules. For a dual receiver UE there is today no explication on how it should select on which it would best receive MBMS MTCH / MSCH / MCCH / MICH using its dual receiver capabilities.

###### 6.1.1.1.2 Analysis of the dual receiver UE behaviour

In the above scenario a UE with the above mentioned dual receiver capabilities the UE will always be able to receive the MBMS service it has subscribed. However in order to perform counting and PtP request the UE would still need to perform frequency convergence. The allowed UE behaviour in this case should be clarified in the specifications.

###### 6.1.1.1.3 Backwards compatibility

This proposal is seen as completely backwards compatible, i.e. UEs with the dual receiver capability can operate on Rel-6 networks, and Rel-6 UEs can share the same network as dual receiver UEs.

### 6.1.1.2 Scenario 2: MBMS multicarrier Rel-6 network + optimisations for Rel-7 dual receiver UEs

#### 6.1.1.2.1 Impact

The following points need clarification in the standards and are proposed to be addressed during a work item phase:

- **Additional information on the BCCH / MCCH**  
In order to remove the drawbacks as mentioned above it is necessary that the UE can respond to the counting / MBMS PtP establishment on a different frequency / cell compared to the cell on which the UE is informed about the counting.
- **Linking of counting response / PtP bearer request**  
Also in order to make sure that the RNC can link the counting response / PtP establishment request it is necessary that a UE with dual receiver capabilities that responds to messages received on a MCCH sent on a different cell compared to the cell that the UE is camping on includes some additional information to the message sent to the network.
- **Dual receiver capability indication**  
A UE with dual receiver capabilities for UMTS is able to efficiently receive MBMS services and dedicated services in parallel. However in Rel-6 the network has no information on the limitations of a UE, or the extra freedom that the UE has in order to receive MBMS services. In the case that the UE is able to receive MTCH on a different frequency than the dedicated services it is important to inform the network of this capability, e.g. at RRC connection establishment or any other occasion.
- **MBMS cell selection**  
One additional possibility to facilitate the dual receiver operation would be to link the MBMS cells on Freq B to the cell on Freq A that the UE is camping on. In this way for each cell that the UE is camping on in frequency A an indication would be given which cell or set of cells in frequency B are collocated, and thus restrict the number of cells from which the UE needs to choose for the reception of MBMS services
- **Configuration information**  
In a further step parts of the configuration, e.g. MCCH, MTCH, MSCH and / or radio bearer configuration of the cells and services in the frequency B would be broadcast on the frequency A, such that a UE would only need to receive MTCH / MSCH on the frequency B, but neither BCCH nor MCCH

#### 6.1.1.2.2 Analysis of the dual receiver UE behaviour

In the above scenario a UE with the above mentioned dual receiver capabilities will always be able to receive the MBMS service it has subscribed, without having any impact from MBMS services any more. This allows that the UE does not need to follow frequency convergence for any case, and thus there is no more impact for the UE for the case of simultaneous reception of dedicated and MBMS data.

#### 6.1.1.2.3 Backwards compatibility

This proposal is seen as completely backwards compatible, i.e. UEs with the dual receiver capability can operate on Rel-6 networks, and Rel-6 UEs can share the same network as dual receiver UEs.

### 6.1.1.3 Scenario 3: Rel-6 network (single carrier or multicarrier) + separate independent MBMS downlink only frequency for Rel-7 dual receiver UEs (FDD)

#### 6.1.1.3.1 Impact

The following points need clarification in the standards and are proposed to be addressed during a work item phase:

- **Indication that MBMS services are provided**  
In order to allow to have a DL only carrier without receiver equipment it is possible to introduce for Rel-7 DL only MBMS carriers. In order to prevent Rel-6 UEs from reselecting to this DL only MBMS carrier it would be necessary that on this carrier some relevant SIBs are not sent, that they are blocked for operator use or any other possibility that prevents Rel-6 and earlier UEs to select to these cells

- Indication as MBMS DL only carrier  
Once it is taken care of that UEs do not expect cells of Frequency B to provide dedicated service it is necessary that a specific indication broadcast that indicates to UEs that a given cell provides MBMS DL only services, such that UEs with dual receiver recognize the cells in this frequency as cells providing MBMS DL only carrier and listen to the MCCH / MTCH / MICH / MSCH of those cells.
- Optimization of dual receiver activation  
In order to allow Rel-7 dual receiver MBMS UEs to discover MBMS DL only cells efficiently it is necessary to give a specific indication in a Rel-7 extension on BCCH or MCCH, e.g. a MBMS DL only cell info list. This list could also be limited to the cells MBMS DL only cells that have the same coverage as the cells that provide dedicated services. We believe that it should be possible to add inter frequency FDD as well as TDD cells in this extension. Apart from this the above sections cover the necessary extensions in order to allow to address dual receiver UEs.

Specific optimisations for backwards compatibility:

Although it would in principle be possible that UEs without dual receivers could receive MBMS services on a MBMS DL only spectrum (e.g. by moving back to the frequency providing regular services as soon as the UE receives paging messages on the MBMS DL only frequency or when the UE wants to initiate a call) there would be big limitations e.g. in terms of counting, and PtP establishment. Therefore it should be FFS whether it is worthwhile to specify behaviour for UEs without dual receiver capability that would be camping on MBMS DL only cells

#### 6.1.1.3.2 Analysis of the dual receiver UE behaviour

Compared to the above scenarios this scenario does not really bring an advantage for the UE but rather for the network operation. This allows to deploy only the necessary elements for MBMS and allows therefore cost reductions for the deployment of an MBMS dedicated network.

#### 6.1.1.3.3 Backwards compatibility

This proposal is not really backwards compatible, Rel-6 UEs can not use the standalone MBMS frequency, but they can continue to use the Rel-6 carrier. The standalone carrier can be used in order to map "enhanced" services that are linked to a UE with the necessary capabilities.

### 6.1.2 FDD + TD-CDMA DL

#### 6.1.2.1 Scenario 1: Non-integrated RAN

For the non-integrated RAN scenario, TDD is used for the delivery of MBMS traffic and its related downlink control information. The MBMS service is broadcast over the entire service area using TDD MBMS (p-t-m) bearers regardless of the number of users that have activated the service in the service area. The control information with respect to the higher layer MBMS service announcement and service activation are communicated over FDD. The UE is required to have minimum capability of TDD/FDD dual receiver and FDD transmitter. We refer to this UE as FDD with Downlink Only TDD (FDOT).

The service announcement and service activation are carried out using higher layer NAS signalling over default unicast radio bearers. The MBMS service is broadcast in the entire service area covered by TDD for the duration of the service regardless of the user's service activation. The MBMS p-t-m bearer is used to deliver the service. As two separate bearers are used for higher layer signalling and MBMS traffic, no interaction between TDD and FDD networks is required at the RAN level.

While in the TDD coverage area, the FDOT UE can receive the MBMS services over TDD. When the FDOT UE is not in the TDD coverage area, the FDOT UE can receive the service either via an FDD unicast bearer or FDD p-t-p/p-t-m MBMS bearer.

For the non-integrated RAN scenario, the higher layer signalling can be communicated over an established (or default) PDP context, which is associated with the FDD element of the FDOT UE. Thus, there are no requirements for the FDD part of the FDOT UE or for that matter the FDD RAN to have MBMS capabilities. However, the TDD downlink only element of the FDOT UE is required to be MBMS capable as is the TDD RAN.

In summary, the non-integrated RAN scenario can be implemented over a pre/post-Rel.6 FDD RAN and Rel.6 TDD RAN. This scenario is well suited to the provision of MBMS broadcast applications such as mobile TV, where the same application content is broadcast at a given time everywhere in the network.

## 6.1.2.1.1 Architecture/network implication

Figure 8 depicts the MBMS network architecture showing MBMS related entities involved in providing MBMS over TDD.

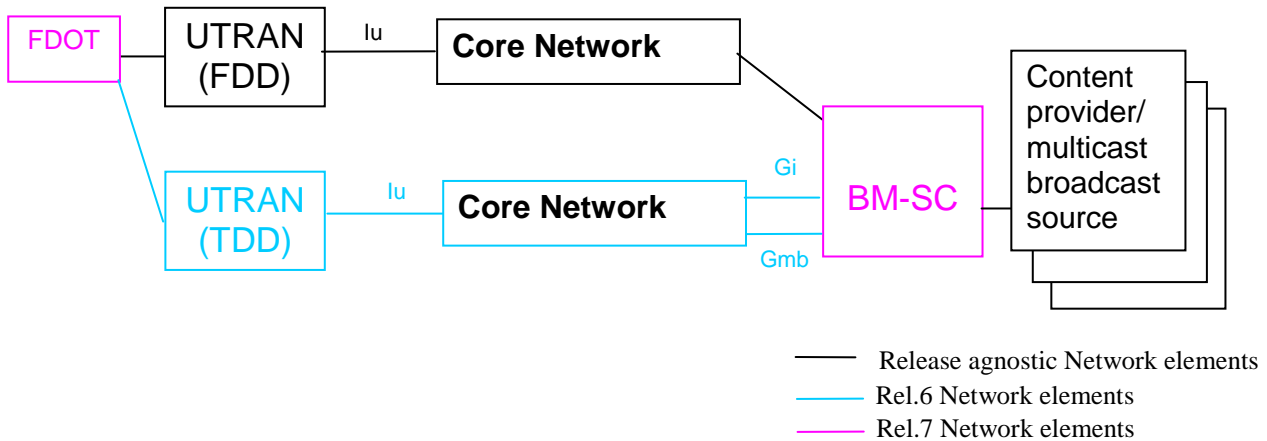

**Figure 8: Network infrastructure of overlay MBMS using TDD: non-integrated RAN.**

An overlay TDD UTRAN is used to deliver the MBMS related traffic using point-to-multipoint delivery. The FDD UTRAN and TDD UTRAN are connected to the core network over separate lu interfaces. There is no need for "tight coupling" between the FDD and TDD UTRAN elements, either with a common FDD and TDD RNC or with the provisioning of an interface interconnecting the TDD RNC and FDD RNC.

Figure 9 illustrates signalling flow involved in allowing the FDOT UE to enable the MBMS broadcast mode over overlay TDD in non-integrated RAN scenario.

In "non-integrated RAN" scenario, MBMS service context (MBMS service ID, MBMS Bearer Service Type, MBMS session Attributes (MBMS service area information, QoS parameters)) is established in UTRAN-TDD (in the service area) for all the MBMS services available for the duration of the session. UTRAN-TDD broadcasts the available MBMS services over the entire service area covered by TDD for all the active services.

If a user has activated the service while out of TDD coverage area, the service is made available to the UE over FDD MBMS (p-t-p or p-t-m) bearers when Rel.6 FDD UTRAN is used. Otherwise, the service is provided over FDD unicast bearers and the 3GPP PSS service supported by the BM-SC, when a pre-Rel.6 FDD UTRAN is being used, following the procedures defined in [2] and [3] SA WIs. This would provide service continuity at the edge of the TDD coverage area. The procedures used are described in subclause 2.3.

It is assumed that the terminal always has in place the default PDP Context that is automatically setup upon the terminal's bootstrap over the FDD UTRAN. The sequence of actions in order to allow the FDOT UE to enable the MBMS broadcast mode over TDD UTRAN is the following.

1. The FDOT UE uses the "default PDP Context" over FDD mode in order to receive the MBMS Service Announcement, using interactive service announcement mechanisms over point-to-point bearers as described in [3] and [4]. The service announcement document is structured according to the XML schema defined in [4], in more detail the User Service Description instance will contain an <accessGroup> element with an <accessBearer> child element indicating the fact that the delivery of this MBMS service is performed using TDD broadcast bearers or FDD MBMS bearers. After the service announcement document is parsed the terminal fetches the service description document from the URL contained in the <sessionDescriptionURI> element, over the default PDP context. The session description document contains the TMGI for this MBMS service in SDP parameter as defined in [4].

Note that as the pre-Rel.6 FDD network is not capable of supporting MBMS. Hence, the service announcement (in case of Non-integrated RAN with pre-Rel.6 FDD and Rel.6 TDD) indicates that the MBMS service is supported only over TDD.

2. The terminal performs the MBMS service registration procedures as defined in [3] and [4], where the necessary authentication mechanisms are performed in the BM-SC. All this message exchange is performed

over the FDD default PDP context. Before proceeding with the service registration, the terminal should check whether there is TDD coverage in the area and the FDOT UE capability of receiving MBMS over TDD.

3. The terminal performs the MSK request procedures as described in [5], in order to be able to derive the MTK key and decrypt the received SRTP-encrypted multimedia traffic. The MBMS multimedia traffic is encrypted with SRTP using the MTK key. This allows operators to apply charging for the reception of the MBMS traffic.
4. Given that in step 1 the <accessBearer> element of the service announcement was indicating that the multimedia traffic for this MBMS service is delivered over TDD MBMS bearers, the terminal starts listening to the MCCH of the TDD UTRA in order to identify the appropriate MTCH for the TMGI that defines this MBMS service.
5. After identifying the appropriate service information, the FDOT UE "tunes in" to the appropriate TDD MTCH to start receiving the multimedia MBMS traffic. It uses the MTK derived from the MSK procedures as described in [5] in order to decrypt the received multimedia traffic.

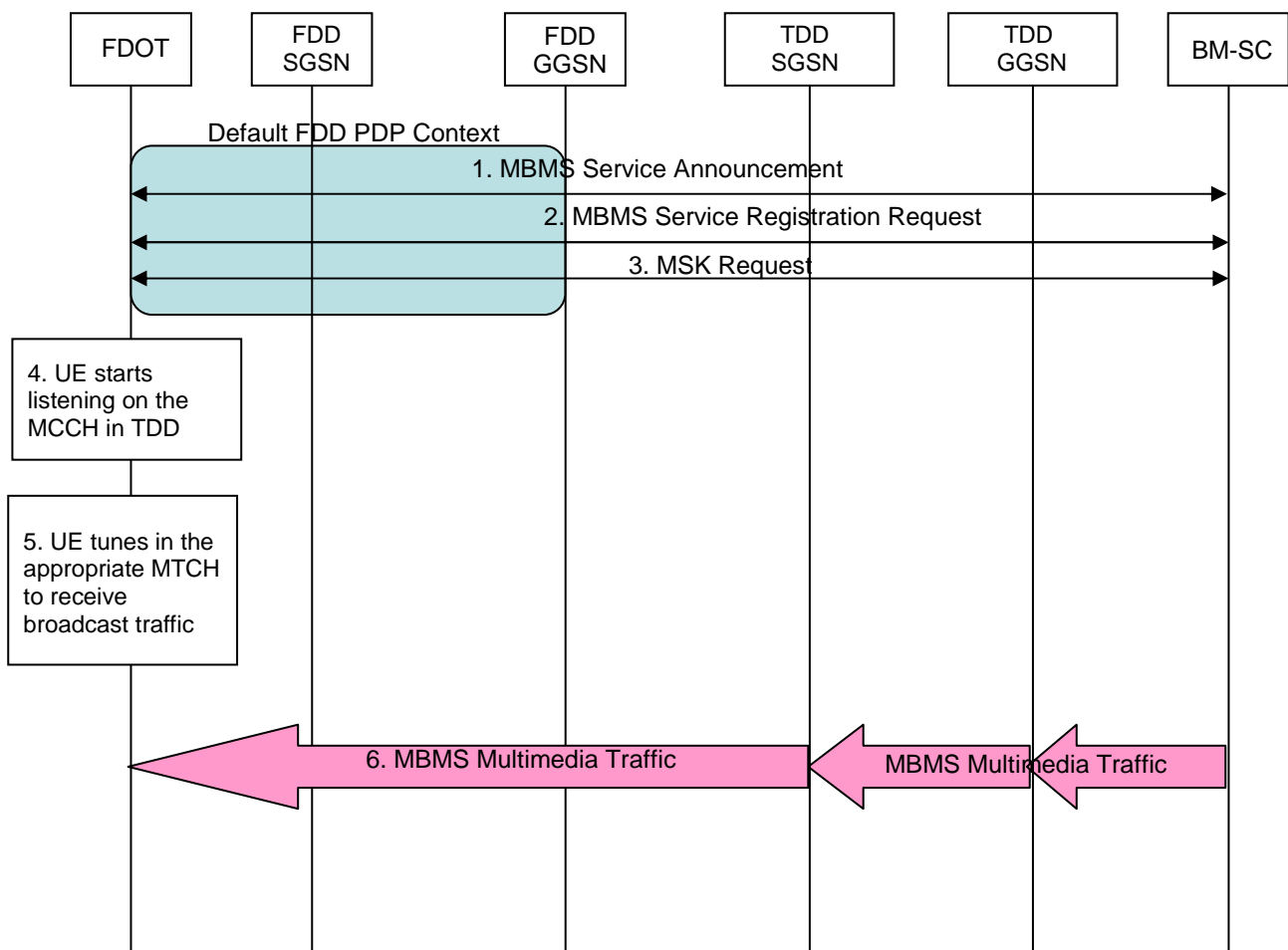

Figure 9: Signalling flow seen in MBMS using UTRA TDD: non-integrated RAN scenario.

Note that the UE does not require a common Radio Resource Management layer between the FDD and TDD modes of operation. The "convergence" of the MBMS User service procedures is performed in higher layers of the UE's protocol stack and in the BM-SC..

6.1.2.1.2 Functions and procedures

The service announcement document which is structured according to the XML schema defined in [4] should be modified to include the delivery of MBMS traffic over unpaired/TDD spectrum and/or paired/FDD spectrum while service announcement is over FDD.

In the current Rel.6 system, MBMS broadcast services only requires activating the service locally at the FDOT UE in order to receive the service. However, according to the overlay TDD system with non-integrated RAN scenario requires the FDOT UE to perform service registration and to acquire MBMS Security Keys in order to receive the MBMS service. Thus, service announcements need to be modified to include the requirement for service registration in order to receive the TDD MBMS service.

Note that service announcement, service registration and MBMS security key request are NAS procedures which are out of the RAN scope. In the interest of completeness this information has been provided.

To receive an MBMS service, the FDOT UE should be directed to the appropriate channel carrying the MBMS traffic. If the service is available over TDD, after the successful service registration/security key request procedure, the FDOT UE listens to the system information (BCCH) on the TDD cell and discovers the MCCH, MICH, MSCH and MTCH channels over TDD.

As the MBMS service is broadcast over the TDD cell independently of the number of users which have activated the service in the cell, no counting procedure is required. Also no UL communication is carried out over the unpaired spectrum. As the MBMS service is available in every cell at a given time instance, neither URA update nor Cell update is required on the TDD cell/URA change.

The functional procedures required for the reception of MBMS over TDD with non-integrated RAN scenario can be described in three main steps as illustrated in Figure 10.

Step 1: The FDOT UE (with dual receiver capability) receives the MBMS service announcement over FDD spectrum. The service announcement may take place before the session starts and/or during the session. Thus, the MBMS service may already be broadcast over TDD spectrum. The FDOT UE would not be able to receive the service yet, as it does not have necessary security keys to decode the MBMS traffic.

Step 2: The FDOT UE performs the service registration over the default PDP context on UTRAN-FDD and obtains the necessary security keys for the service.

Step 3: The FDOT UE receives the MBMS service.



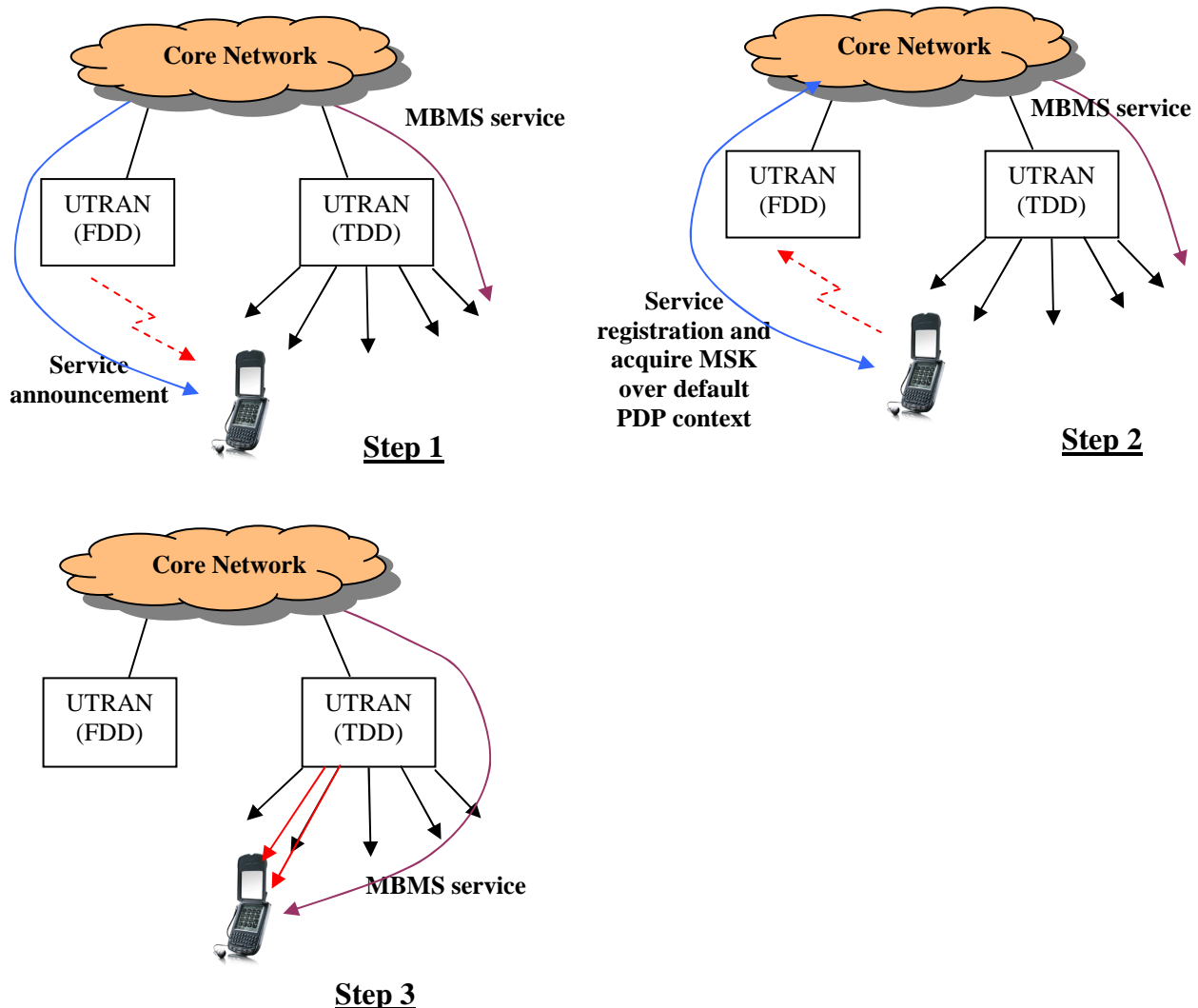

Figure 10: Steps involved in reception of MBMS service over TDD according to non-integrated RAN scenario.

### 6.1.2.1.3 Support of service continuity

#### 6.1.2.1.3.1 Mobility in intra-TDD cells

The FDOT UE mobility between TDD cells within the service area does not affect the MBMS reception.

If the FDOT UE moves between TDD cells which belong to the same MBMS cell group, the FDOT UE is not required to re-establish an RLC entity and a re-initialise PDCP entity for the service received. However, if the cells belong to different MBMS cell groups, then the FDOT UE is required to re-establish the RLC and re-initialise the PDCP entities.

#### 6.1.2.1.3.2 Support of service continuity

The FDOT UE service registration and MSK request procedure is carried over FDD using the default PDP context and the procedures are transparent to the FDD UTRAN elements. Also, the FDD UTRAN does not establish an MBMS service context at the RNC thus no MBMS bearer is established over FDD. This situation causes loss of service when the user moves away from the TDD coverage area. The loss of service at the edge of the TDD coverage area can be avoided by enabling the FDOT UE to request MBMS service in FDD UTRAN over unicast FDD bearers using PSS service supported by the BM-SC in Rel.7, from the SA WIs [2] and [3].

Two different procedures for support of service continuity at the edge of TDD coverage can be envisaged depending on what release (Rel.6 or pre-Rel.6) is used for FDD UTRAN.

### 6.1.2.1.3.3 Service continuity in pre-Rel.6 FDD UTRAN

When the TDD signal strength is reduced below a pre-defined threshold, the FDOT UE initiates a RRC connection request in order to establish a streaming bearer for the reception of MBMS. If the core network is capable of delivering the MBMS service over streaming bearers, a streaming bearer is established between the FDOT UE and the network. Thus the MBMS traffic is delivered over the streaming bearer in pre-Rel.6 FDD UTRAN.

The FDOT UE behaviour at the edge of the TDD coverage area is illustrated in Figure 11. During the time interval  $T_0$  to  $T_1$  the TDD signal strength is good hence the perceptual quality received is also good. At  $T_1$  the TDD signal strength reaches the pre-defined threshold value  $Th_1$ , which determines the FDOT is being close to the edge of the TDD coverage area. The FDOT initiates a RRC connection request in order to establish a streaming bearer at  $T_1$ . At  $T_2$  a streaming bearer is established and MBMS is delivered over FDD. During  $T_1$  to  $T_2$  interval, the FDOT receives TDD signal even though with a degraded signal strength. Smart application procedure such as forward and backwards error concealment mechanisms, could recover the service from the degraded signal received during  $T_1$  to  $T_2$  period. With appropriate settings of  $Th_1$  and advanced application procedures, the service interruption seen at the edge of the TDD coverage area can be minimised.

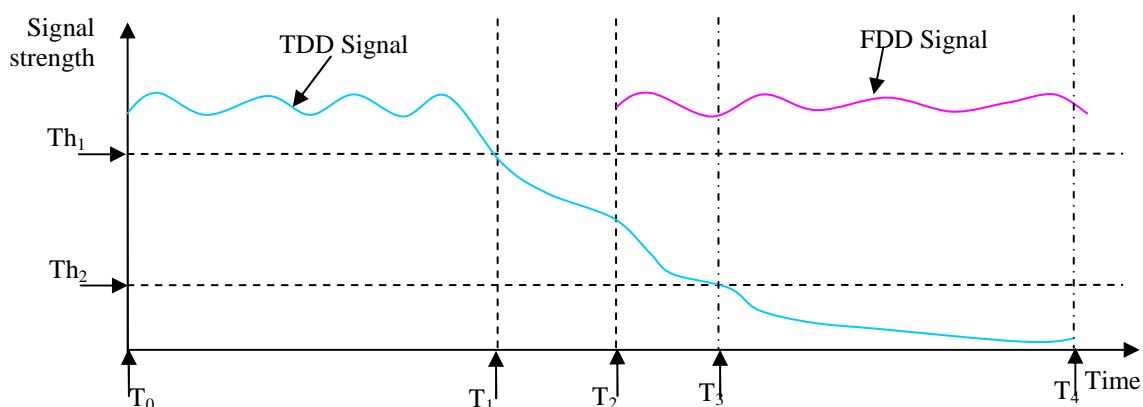

$T_0 - T_1$  Good quality MBMS over TDD

$T_2 - T_4$  Good quality MBMS over FDD

$T_1 - T_2$  Moderate to good quality MBMS (use error concealment and smart application layer procedure)

$T_1$  - Request for streaming bearer

$T_2$  - Streaming bearer establishment

$T_3$  - Loss of MBMS service over TDD

$Th_1, Th_2$  - threshold values

**Figure 11: The FDOT UE behaviour at the edge of the TDD coverage area.**

When the FDOT UE returns to a TDD coverage area from out of TDD coverage, the FDOT UE acquires MCCH information if the interested MBMS service is available in the TDD cell for the reception of the service. If the FDOT UE was receiving the MBMS service over MBMS p-t-p or streaming bearer in FDD UTRAN, the FDOT UE informs the reception of MBMS over TDD to the FDD UTRAN. Thus, the FDD UTRAN initiates connection release for the streaming bearer over FDD.

### 6.1.2.1.3.3 Service continuity in Rel.6 FDD UTRAN

The FDOT UE informs the FDD UTRAN for the loss of MBMS service due to the loss of TDD coverage. This can be informed by initiating a Cell update procedure or RRC connection procedure with the cause is set to "loss of MBMS over TDD" and including the MBMS service ID. FDD UTRAN establishes MBMS p-t-p (or p-t-m) bearer for the delivery of the corresponding MBMS service to the FDOT UE.

When the FDOT UE returns to a TDD coverage area from out of TDD coverage, the FDOT UE acquires MCCH information if the interested MBMS service is available in the TDD cell for the reception of the service. If the FDOT UE was receiving the MBMS service over MBMS p-t-p bearer in FDD UTRAN, the FDOT UE informs the reception of

MBMS over TDD to the FDD UTRAN. Thus, the FDD UTRAN initiates connection release for the p-t-p bearer over FDD.

#### 6.1.2.1.4 Connection state of the UE

Only downlink transmission is available in TDD UTRAN. Therefore, the FDOT UE could only be in Idle state in TDD UTRAN. However, the FDOT UE may be in connected (CELL\_DCH, CELL\_FACH, URA\_PCH or CELL\_PCH) or Idle states (depending on the FDOT UE activity) in FDD UTRAN while receiving the MBMS traffic over TDD UTRAN.

#### 6.1.2.1.5 Specification Impacts

##### **Modification required for Rel.5/6 RAN specification**

No modification requires.

##### **Modification required for Rel.7 RAN specification**

**TDD BCCH information:** In one deployment scenario TDD spectrum is used solely for the delivery of MBMS, system information transmitted over BCCH needs modification as some information (such as RACH information) may not be required.

If the MBMS service is provided only over a portion of TDD spectrum while non-MBMS services are supported over the remaining portion of TDD spectrum for TDD Rel.6 UEs, no modification is required to BCCH. This would allow backwards compatibility to TDD Rel.6 UEs.

FDOT UEs may be unaware of whether the MBMS service is provided over a portion of TDD spectrum or the entire TDD spectrum. Hence the BCCH information on the system which uses entire TDD spectrum for the delivery of MBMS service should be structured such a way to allow the FDOT UE to follow a common procedure in acquiring MCCH information in both deployment scenarios.

**Cell update/RRC connection procedure:** The MBMS service ID should be included in the cell update and RRC connection procedure in case they are initiated with related to MBMS loss/reception over TDD.

**Reception of MBMS over TDD/FDD:** at some geographical location, a FDOT UE may receive the same MBMS service over both TDD and FDD. In this scenario, a FDOT UE procedure should be defined such that the FDOT UE may select signals over TDD or FDD or the FDOT UE may receive both signals and perform selective combining at the application layer.

##### **Modification required for Rel.7 SA specifications**

**Service announcement:** The parameter within the service announcement document should be modified to indicate the service is available over TD-CDMA downlink carrier only or is available over either FDD (in case no TDD coverage) or TD-CDMA downlink carrier.

**Service registration/MSK request:** The FDOT UE is required to perform service registration and to acquire MBMS Security Keys in order to decode the MBMS service, which is delivered to RAN using broadcast delivery method.

**MBMS over streaming bearers:** modification is required at the multimedia service centre in order to provide MBMS services over streaming bearers.

Note: This is only applicable if pre-Rel.6 FDD UTRAN is used.

Note that both service announcement and service registration/MSK request mechanisms are out of scope of the RAN activities; hence modification required should be addressed in the relevant SA specifications.

#### 6.1.2.1.6 Benefits and drawbacks

##### **Benefits**

MBMS over TDD with "non-integrated RAN scenario with Rel.6 FDD and TDD" supports high bit rate MBMS delivery without impacting the quality of on going dedicated services such as voice or data. The other benefits include:

- The MBMS can be supported in Rel.6 or pre-Rel.6 FDD UTRAN with overlay Rel.6 TDD UTRAN.
- No upgrade is required to the existing UTRAN-FDD network.
- No impact on the core-network

- No additional RAN procedures are required to support the MBMS service.
- No counting procedure is required for support of MBMS over TDD.
- Provide service continuity at the edge of the TDD coverage area
- Ideally suited to "mobile-TV-like" applications

#### **Drawbacks**

- MBMS service is broadcast in the entire service area regardless of the number of FDOT UEs activating the service in the cell. This could result in inefficient radio resource utilization in TDD cells depending upon the nature of the services being offered.
- Small increase in UL loads in UTRAN-FDD from cell update/ RRC connection, service joining/leaving due to the MBMS support in TDD.

### 6.1.2.2 Scenario 2: Integrated RAN

For the integrated RAN scenario, TDD is used as a downlink auxiliary carrier to FDD UTRAN for the delivery of MBMS traffic and its related downlink control information. Multicast signalling procedures over FDD are used for the service establishment. The UE is required to have a minimum capability of TDD/FDD dual receiver and FDD transmitter. We refer to this UE as FDD with Downlink Only TDD (FDOT).

The MBMS services are delivered over either FDD or TDD bearers depending on the radio requirements. P-t-m bearers are being used for MBMS support over TDD. The MBMS service is made available over TDD cells only if the number of users, who have activated the service in the cell, is larger than a pre-defined threshold. Otherwise, the MBMS service is provided to the activated users using point-to-point connection over FDD carriers. This requires interaction between FDD and TDD networks at UTRAN level.

While in the TDD coverage area, the FDOT UE can receive the MBMS services over TDD. When the FDOT UE is not in the TDD coverage area, the FDOT UE can receive the service via an FDD p-t-p/p-t-m MBMS bearer.

In the integrated RAN scenario, FDD UTRAN makes the decision on the support of MBMS over FDD p-t-p/p-t-m MBMS bearer or TDD p-t-m MBMS bearer depending on the service demand. This provides an efficient resource management in UTRAN.

In addition, the integrated RAN scenario allows fast switching (low service interruption) between MBMS delivery over TDD and FDD MBMS bearers. This is specially benefited in enabling service continuity at the edge of TDD coverage areas.

As the UE service joining and leaving at any time is allowed in the integrated RAN scenario, more flexible charging models can be applied.

Two different deployment scenarios are investigated under the "Integrated RAN" scenario. The first scenario is based on the Rel.6 MBMS framework and this does not have any impacts on the core network elements or BM-SC. However, this requires an Iur (logical) interface between the FDD RNC and TDD RNC. This is referred to as "Integrated RAN based on Rel.6 MBMS framework" in this document.

The second scenario is based on "one tunnel approach", which is being investigated in SA2 [1] to enable direct tunnelling for user plane between RNC and GGSN within PS domain. The one tunnel approach has also been proposed in [2] as an UTRAN evolution to achieve LTE architectural benefits for HSPA by gradual introduction of a flat network architecture. This is referred to as "Integrated RAN based on one-tunnel approach" in this document.

6.1.2.2.1 Architecture/network implication

6.1.2.2.1.1 Integrated RAN based on Rel.6 MBMS framework

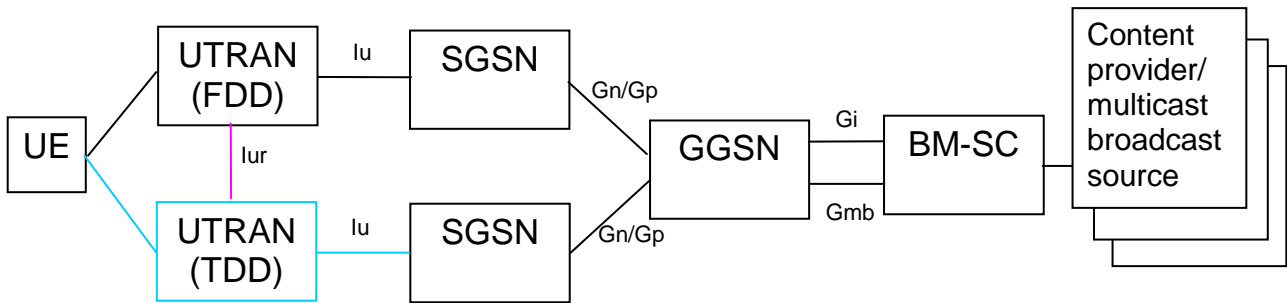

**Figure 12: Network infrastructure of overlay MBMS using TDD: integrated RAN based on Rel.6 MBMS framework.**

Figure 12 depicts the MBMS network architecture showing MBMS related entities involved in providing MBMS over TDD in an "Integrated RAN based on Rel.6 MBMS framework". The MBMS service is delivered over the overlay TDD network. Both UTRAN-FDD and UTRAN-TDD is assumed to use a common GGSN. FDD-RNC is connected to TDD-RNC via Iur interface.

Figure 13 illustrates signalling flow involved in allowing the UE to enable the MBMS multicast mode over overlay TDD in "Integrated RAN based on Rel.6 MBMS framework". The sequence of actions in order to allow the UE to enable the MBMS multicast mode over TDD UTRAN is the following.

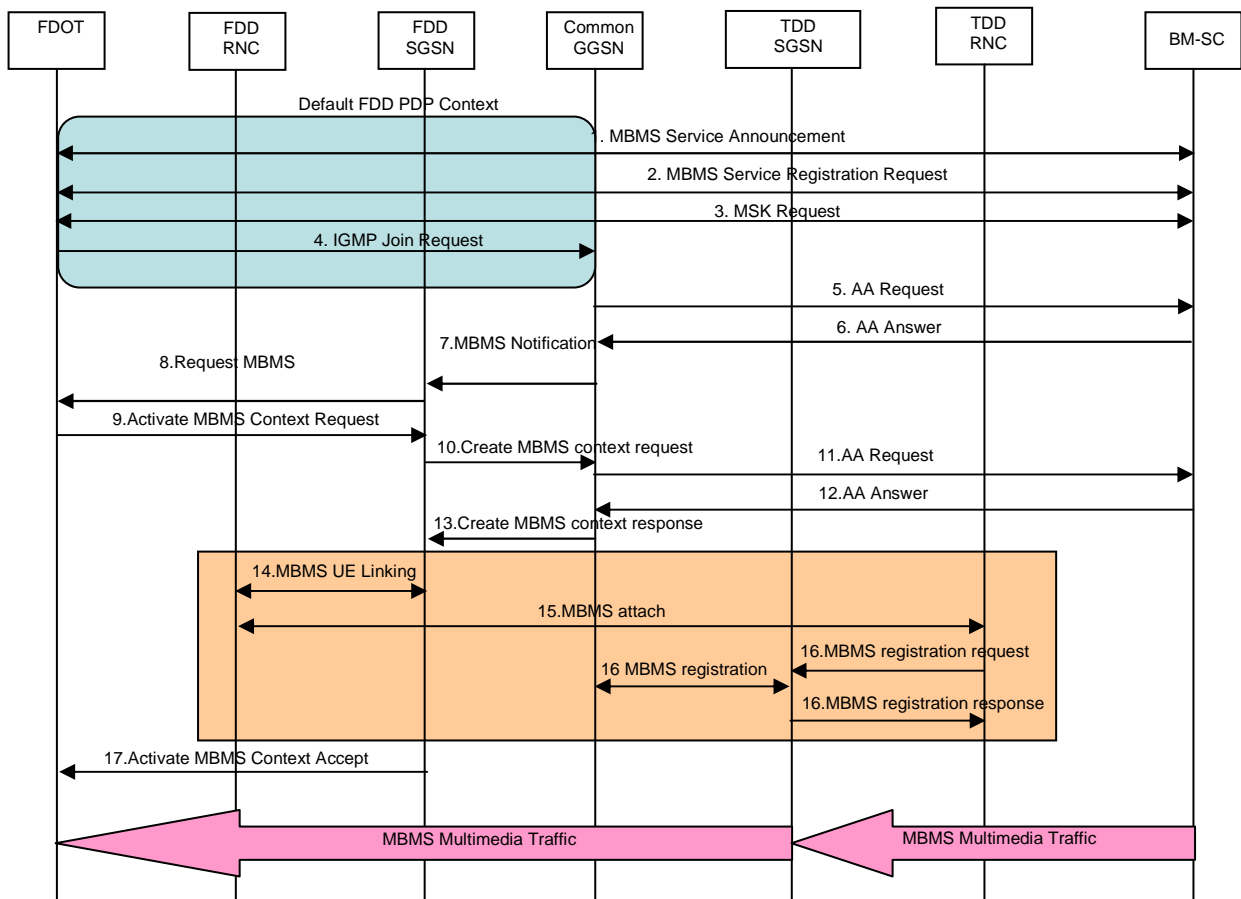

**Figure 13: Signalling flow seen in MBMS using UTRA TDD: Integrated RAN based on Rel.6 MBMS framework.**

1. The terminal uses the "default PDP Context" over FDD mode in order to transport the MBMS Service Announcement, using interactive service announcement mechanisms over point-to-point bearers as described in [3]. The service announcement document is structured according to the XML schema defined in [3]. In more detail the User Service Description instance will contain an <accessGroup> element with an <accessBearer> child element indicating the fact that the delivery of this MBMS service is performed using either TDD p-t-m or FDD p-t-p bearers. In the same descriptor it is indicated to the terminal whether the service will use multicast or broadcast delivery mode.
2. The terminal performs the MBMS service registration procedures as defined in [4], where the necessary authentication mechanisms are performed in the BM-SC. All this message exchange is performed over the FDD default PDP context.
3. The terminal performs the MSK request procedures as described in [4], in order to be able to derive the MTK key and decrypt the received traffic multimedia traffic.
4. The terminal sends an "IGMP Join" request to the multicast group that is interested to join over the default PDP context using FDD unicast bearers, the IP multicast address of the group is extracted from the SDP description document for this particular MBMS service. The FDD GGSN receives the "IGMP Join" request as in [5].
5. The FDD GGSN initiates the appropriate Gmb interface signaling in order to request authorization from the BM-SC for the terminal with the particular IMSI to receive traffic for this particular multicast group.
6. The authorization decision, which is based on subscription data in the BM-SC, is provided in the MBMS Authorization Response together with the APN to be used for creation of the MBMS UE context.  

Note: In this case, common GGSN for TDD and FDD networks is assumed. Hence the APN points to the common GGSN.
7. The GGSN sends an MBMS Notification Request (IP multicast address, APN, Linked NSAPI) to the FDD SGSN. Linked NSAPI is set equal to the NSAPI of the PDP context over which the Join request was received. The IP multicast address is the one requested by the UE in the Join request. The APN indicates the APN of the common GGSN selected by BM-SC. If the request is received correctly, the SGSN acknowledges the received message to the GGSN, this message is omitted from the signalling flow for simplicity.
8. The FDD SGSN sends a Request MBMS Context Activation (IP multicast address, APN, Linked NSAPI) to the UE to request it to activate an MBMS UE Context. The Linked NSAPI allows the UE to associate the MBMS UE Context with the PDP context over which it sent the IGMP Join message in step 4.
9. The UE creates an MBMS UE context and sends an Activate MBMS Context Request message to the FDD SGSN. The message includes IP Multicast address, APN, MBMS\_NSAPI, and MBMS bearer capabilities. The IP multicast address identifies the MBMS multicast service, which the UE wishes to join to, while APN indicates the common GGSN. The MBMS bearer capabilities indicate the maximum QoS the UE can handle.
10. The FDD SGSN creates an MBMS UE context and sends a Create MBMS Context Requests (including IP multicast address, APN, MBMS\_NSAPI, IMSI, MSISDN, RAI, IMEI-SV, RAT Type) to the GGSN.
11. The GGSN sends an MBMS Authorization Request (including IMSI, MSISDN, RAI, IMEI-SV, RAT Type, CGI/SAI) seeking authorization for the activating terminal.
12. The authorization decision is provided in the MBMS Authorization Response. The BM-SC creates an MBMS UE Context. If no TMGI has been allocated for this MBMS bearer service, the BM-SC will allocate a new TMGI. This TMGI will be passed to the common GGSN via the MBMS Registration Response message.
13. The GGSN creates an MBMS UE context and sends a Create MBMS Context Response to the FDD SGSN.
14. The FDD SGSN provides to the RAN the MBMS UE context via the MBMS UE linking procedure. The signaling flow is used to link a specific UE to one or several MBMS service context in the FDD RNC. The message contains the list of MBMS service IDs activated by the UE. If there has not been an MBMS service context related to an MBMS service Id then the FDD RNC creates an MBMS service context as a result of this procedure.

15. The MBMS UE context is established at the TDD RNC as a result of MBMS Iur UE linking via "MBMS Attach" procedure. This procedure requires an Iur interface between FDD RNC and TDD RNC. During the procedure, the information related to a particular MBMS service, which is activated by the UE is delivered to the TDD RNC. The information includes APN and IP multicast address for the particular MBMS service, i.e.:TMGI.
16. The "MBMS Registration" procedure is initiated by the TDD RNC, in the case if there is no MBMS service context for the MBMS service in this RNC. The procedure is initiated by the TDD RNC, as soon as a MBMS Iur UE linking is received and there is no existing MBMS context for the required MBMS service.
 

Note: During the procedure described in steps (15) and (16), the MBMS service context for the required service is established at both FDD and TDD RNCs.
17. The FDD SGSN sends an Activate MBMS Context Accept (TMGI, MBMS bearer capabilities) to the terminal. The terminal after the MBMS context is established starts receiving the MBMS multimedia traffic, in case encryption is used the MTK is utilised to decrypt the received traffic.

#### 6.1.2.2.1.2 Integrated RAN, using the "one tunnel" approach

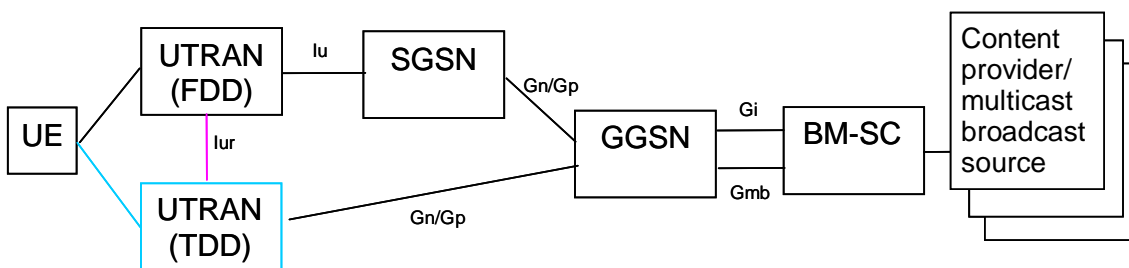
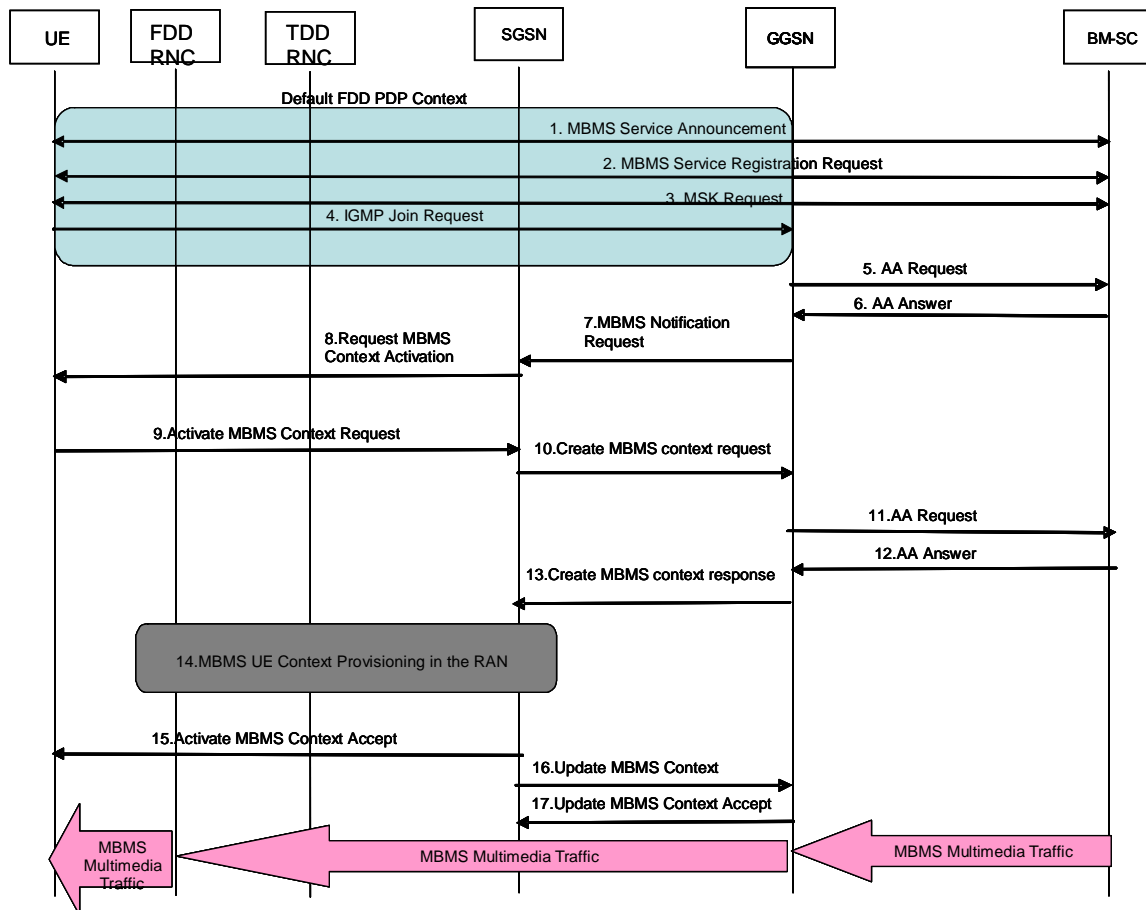

**Figure 14: Network infrastructure of overlay MBMS using TDD: integrated RAN using the "one tunnel" approach**

3GPP SA2 is working in [1] in an optimized architecture for the delivery of PS services over the CN. The essence of this architecture is the by-passing of the SGSN for the delivery of the PS user plane traffic from the GGSN to the RAN. Additional functionality is added in the GGSN and SGSN CN nodes to make this possible.

What is proposed in this architecture approach is that for the case of the FDOT UEs the termination of the Gn tunnel (GTP-U) for the case of the MBMS traffic is going to terminate to the TDD RNC directly. That way the maximum efficiency is performed both in terms of air-interface, but also CN nodes' utilization. It is understood that a number of modifications in the CN nodes and interfaces involved is necessary for this architectural approach, but given that SA2 is working on the evolution of the "one tunnel" architecture at the moment, additions to this working document can be performed in a timely manner.

This tdoc proposes a possibility for a set of modifications that can adapt the integrated RAN solution for the delivery of MBMS service traffic over TDD to the "one tunnel" approach. Nevertheless if this is the preferred architecture liaising with 3GPP SA2 is necessary in order to achieve alignment.



**Figure 15: Signalling flow seen in MBMS using UTRA TDD: Integrated RAN using the "one tunnel" approach**

Steps 1-4: The signalling procedures described in subclause 2.1.1.1, utilising the default PDP context over FDD bearers apply. The service announcement indicates that the transport of the MBMS traffic is going to take place over the TD-CDMA network.

Steps 5-9: The signalling procedures described in subclause 2.1.1.1 apply.

Step 10: The message "Create MBMS Context Request" following the "one tunnel approach" described in [1][6] indicates the reserved "not allocated" value for the traffic path as the Iu bearer is not yet allocated in the RAN.

Step 11-13: The signalling procedures described in subclause 2.1.1.1 apply.

Step 14: The SGSN allocates the appropriate resources in the RAN for the MBMS context by exchanging signalling information with the FDD and TDD RNCs, separating the CP and UP paths over the Iu and Iur interfaces. Similar procedures with the ones defined in section 2.1.1.1 for the messages 14-16 apply.

Step 15: The signalling procedures described in subclause 2.1.1.1 apply.

Step 16: After the MBMS Context is provisioned in the RAN the SGSN updates the MBMS context indicating to the GGSN the RAN address and the TEID of the TDD RNC.

Step 17: The GGSN updates the MBMS Context and returns the Update MBMS Context Response message. The tunnel between the GGSN and the TDD RNC is established.

The GGSN in that case will send the MBMS user plane traffic directly to the TD-CDMA RNC following the "one tunnel" approach defined in 3GPP.



### 6.1.2.2.2 Functions and procedures

The service announcement document which is structured according to the XML schema defined in [3] should be modified to include the delivery of MBMS traffic over unpaired/TDD spectrum and/or paired/FDD spectrum while service announcement is over FDD.

The UE is required to join the service in order to receive the necessary security keys to decode the MBMS traffic. The same joining procedure as in Rel.6 can be used. The UE capabilities (dual receiver capability) should be indicated to the network during the joining procedure.

The FDD-RNC is implicitly registered to the corresponding SGSN via UE linking procedure. After the MBMS context is established at the FDD-RNC, the FDD-RNC sends MBMS Attached request signal to the TDD-RNC over Iur interface. This triggers explicit MBMS registration at the TDD-RNC.

Counting procedure is required to identify the number of users who have activated the service in the system. Counting request is sent over MCCH which is transmitted over either TDD or FDD. However, the counting response from the UE is transmitted over FDD spectrum. When to initiate the counting request is implementation specific and may be controlled by the FDD-RNC according to the UL load condition.

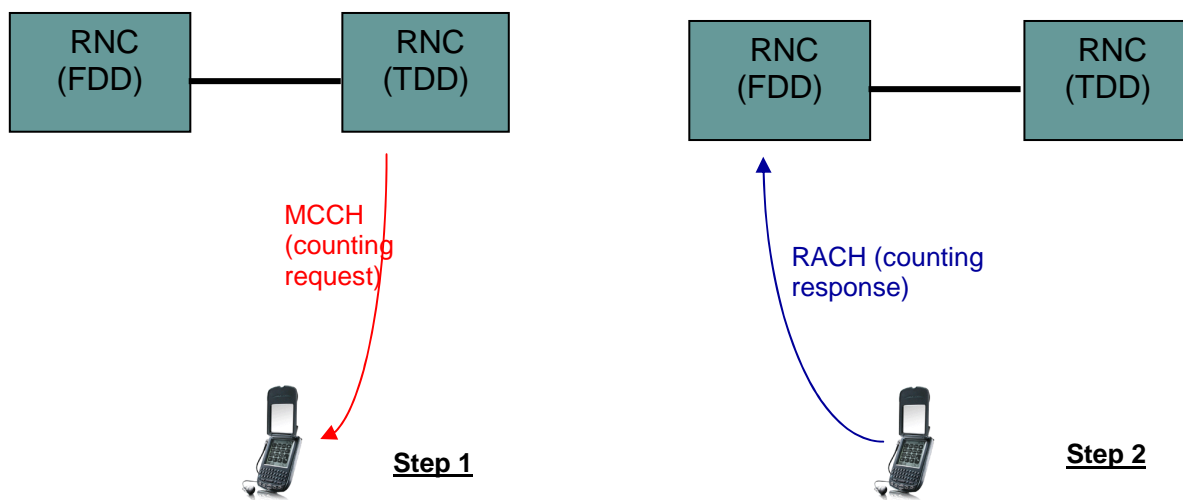

**Figure 16: Steps involved in counting procedure in MBMS over TDD: integrated RAN scenario.**

The transmission mode decision is made by the FDD-UTRAN based on the number of UEs that have joined the service and from the response to counting. If the number of UEs that have joined the service in a TDD cell is larger than a pre-defined threshold, p-t-m TDD bearer is established. Otherwise, p-t-p/p-t-m transmission is established over FDD spectrum. The transition between the two transmission modes is shown in Figure 17. UE linking may trigger the transition from p-t-p to p-t-m. Counting response may trigger the p-t-m to p-t-p transition. If transmission mode is changed, the UEs are informed about the decision over DCCH in FDD.

If the user wishes to leave the service, it initiates a service leaving procedure over FDD to UTRAN-FDD. The leaving does not change the transmission mode.

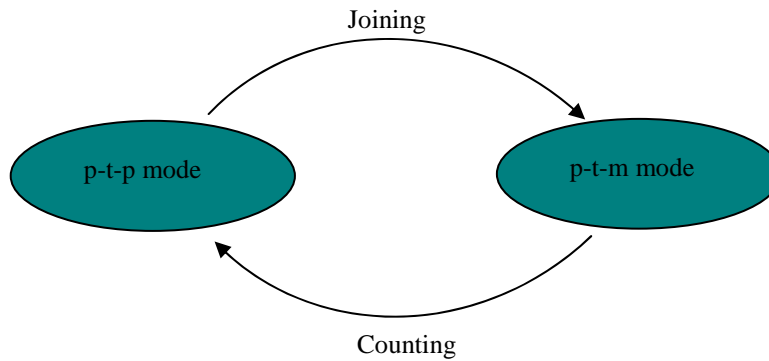

**Figure 17: The transmission mode transition in MBMS over TDD with support of counting.**

The functional procedures required for the reception of MBMS over TDD: integrated RAN scenario with support of counting can be described in seven steps as illustrated in Figure 18.

Step 1: The FDOT UE receives the MBMS service announcement over FDD spectrum. The service announcement may take place before the session starts and/or during the session. Thus, the MBMS service may or may not already being delivered over TDD spectrum. The UE would not be able to receive the service yet, as it has not joined the service.

Step 2: The UE joins the service over UTRAN-FDD. The joining procedure may also trigger MBMS service registration at the TDD RNC via attached procedure over Iur. The MBMS service registration procedure results in MBMS service context available at both TDD and FDD RNC for a given MBMS service. The UE is informed about the transmission mode (p-t-p or p-t-m) and delivery mode (over FDD or over TDD) during the joining procedure.

Step 3: The UE should listen to the BCCH, MCCH, MICH, MSCH and MTCH which are transmitted over the TDD cell. The UE receives the MBMS service over TDD.

Step 4: The UE leaves the service by initiating a leaving procedure over UTRAN-FDD.

Step 5: The FDD-RNC may send counting request over MCCH in TDD.

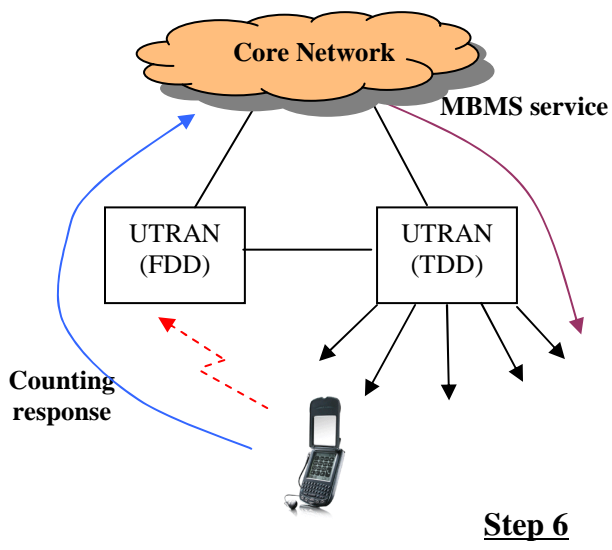
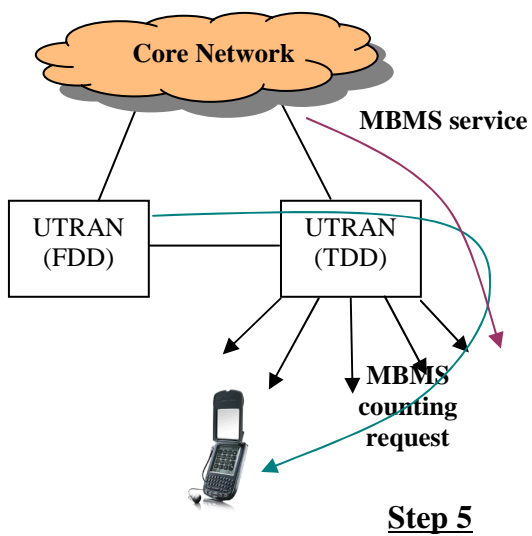
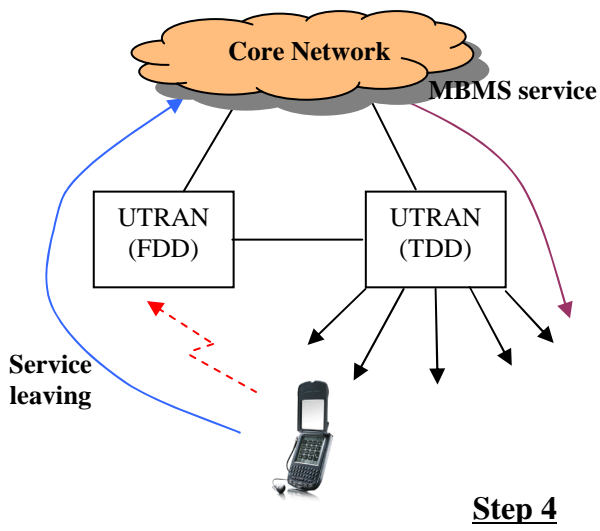
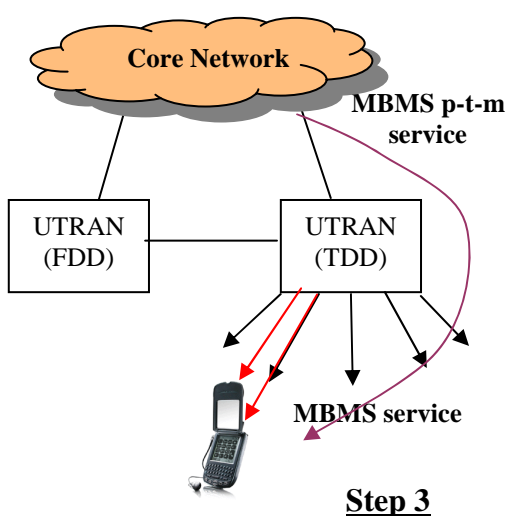
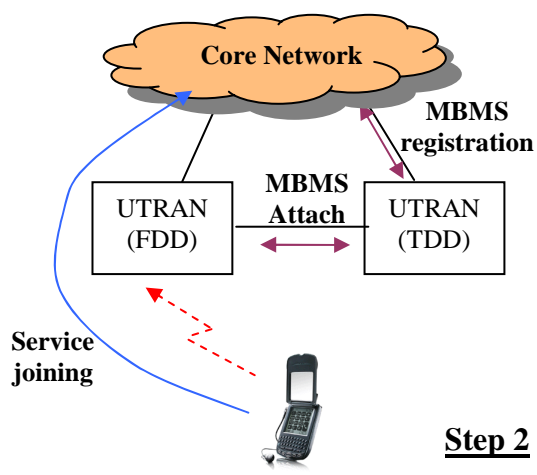
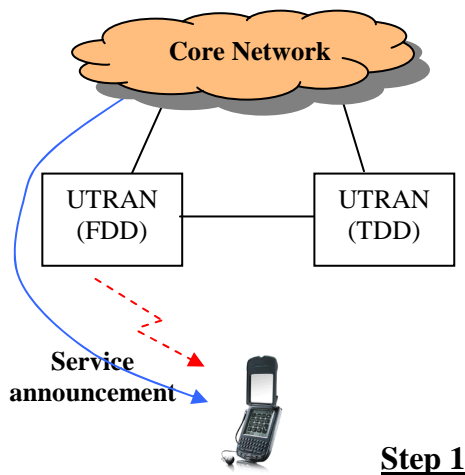

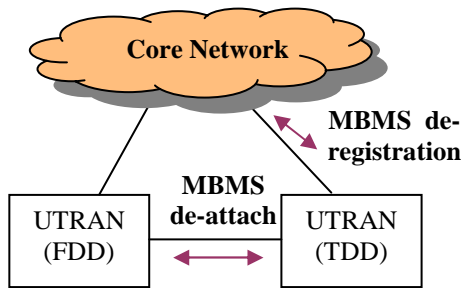

### Step 7

**Figure 18: Steps involved in reception of MBMS service over TDD with support of counting.**

Step 6: The UE responds to the counting request by sending a counting response over FDD UL.

Step 7: The FDD-RNC changes the decision on transmission mode to p-t-p transmission over FDD. This may trigger TDD RNC de-linking and/or TDD-RNC de-registration, which clears the MBMS service context at the TDD-RNC.

#### 6.1.2.2.3 Support of service continuity

Mobility in FDD cells follows same procedures (such as Cell update, URA update) as in Rel.6 specification.

MBMS critical information informing all MBMS services currently configured for p-t-m transmission is periodically transmitted in MBMS activated cells. The critical information also contains radio bearer information for each MBMS service and neighbouring cell information. Thus, the UE mobility between TDD cells does not affect the MBMS reception if the service is available in the cell.

While receiving the MBMS service over TDD, if the FDOT UE moves to a new TDD cell where the service is not available, the FDOT UE first checks whether the service is available over p-t-m MBMS bearer over FDD. If the service is available over FDD p-t-m MBMS bearer, it tunes to the MTCH over FDD and receives the MBMS service over FDD.

If the service is not available either over FDD p-t-m MBMS or TDD p-t-m MBMS bearers, the FDOT UE initiates "Cell Update" or "RRC connection" procedure (depending on the UE states in FDD UTRAN) with cause set to "MBMS p-t-p bearer request" over FDD uplink. The message also contains MBMS ID (or MBMS IDs if more than one service is activated), TDD Cell ID and FDD Cell ID. FDD UTRAN may set up a p-t-p or p-t-m MBMS FDD bearer or p-t-m MBMS TDD bearer and the UE is informed of the delivery mechanism over the dedicated unicast bearer.

If the UE moves to a area where there is no TDD coverage, the FDOT UE initiates "cell update" or "RRC connection" procedure with cause set to "MBMS p-t-p bearer request" over FDD uplink. The message may include the MBMS service ID. FDD UTRAN may set up a p-t-p or p-t-m MBMS FDD bearer and the UE is informed of the delivery mechanism over the dedicated unicast bearer.

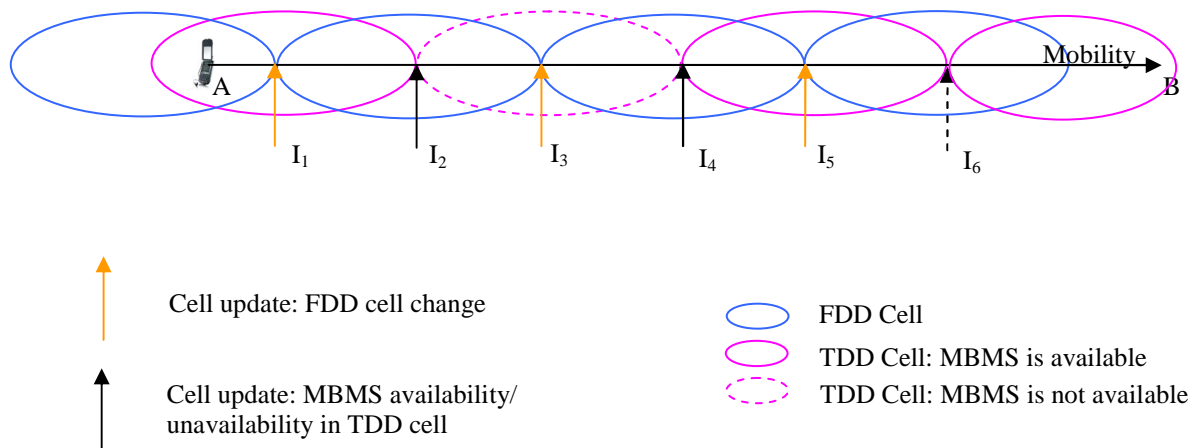

**Figure 19: Cell Update instances seen in overlay TDD MBMS system**

Figure 19 illustrates cell update instances seen in overlay TDD MBMS system. The UE state in FDD is assumed to be CELL\_PCH. The UE moves from point A to point B. a number of cell update instances can be seen. Instances  $I_1$ ,  $I_3$  and  $I_5$  are resulted due to the FDD cell change, thus the same cell update procedure as in Rel.6 is applied. Instance  $I_2$  is resulted because the UE is moving to a TDD cell where the MBMS service is not available. The UE initiates cell update procedure to request a p-t-p MBMS bearer over FDD. The message includes cause: MBMS p-t-p bearer request, MBMS ID (or MBMS IDs if more than one service is activated), FDD cell ID and TDD cell ID. At Instance  $I_4$ , the UE moves to a TDD cell where the service is available over p-t-m MBMS bearer while receiving the MBMS service over FDD p-t-p MBMS bearer. The cell update is sent to the network to inform that the service is available over TDD. The message includes the cause: MBMS reception over TDD, MBMS ID (or MBMS IDs if more than one service is activated), TDD cell ID and FDD cell ID. Even though, the TDD cell is change at Instance  $I_6$ , this would not cause cell update as the MBMS service is available in the cell which the UE is moving to.

#### 6.1.2.2.4 Connection state of the UE

Only downlink transmission is available in TDD UTRAN. Therefore, the FDOT UE could only be in Idle state in TDD UTRAN. However, the FDOT UE may be in connected (CELL\_DCH, CELL\_FACH, URA\_PCH or CELL\_PCH) or Idle states (depending on the FDOT UE activity) in FDD UTRAN while receiving the MBMS traffic over TDD UTRAN.

#### 6.1.2.2.5 Specification Impacts

##### Modification required for Rel.6 RAN specification

No modification requires.

##### Modification required for Rel.7 RAN specification

**TDD BCCH information:** In one deployment scenario TDD spectrum is used solely for the delivery of MBMS, system information transmitted over BCCH needs modification as some information (such as RACH information) may not be required.

If the MBMS service is provided only over a portion of TDD spectrum while non-MBMS services are supported over the remaining portion of TDD spectrum for TDD Rel.6 UEs, no modification is required to BCCH. This would allow backwards compatibility to TDD Rel.6 UEs.

FDOT UEs may be unaware of whether the MBMS service is provided over a portion of TDD spectrum or the entire TDD spectrum. Hence the BCCH information on the system which uses entire TDD spectrum for the delivery of MBMS service should be structured such a way to allow the FDOT UE to follow a common procedure in acquiring MCCH information in both deployment scenarios.

**Cell update/RRC connection procedure:** One new "cause" values as "MBMS reception over TDD" should be added to the list of "cause" values specified to be used in cell update and RRC connection procedures. Furthermore, the MBMS service ID (or MBMS service IDs if more than one service is activated), TDD cell ID and FDD cell ID should also be

included in the cell update and RRC connection procedure in case they are initiated with related to MBMS loss/reception over TDD or to a counting response.

Reception of MBMS over TDD/FDD: at some geographical location, a FDOT UE may receive the same MBMS service over both TDD and FDD p-t-m MBMS bearer. In this scenario, a FDOT UE procedure should be defined such that the FDOT UE may select signals over TDD or FDD or the FDOT UE may receive both signals and perform selective combining at the application layer.

#### **Modification required for Rel.7 SA specifications**

In case of the "one tunnel" architecture changes required in TR23.809. Otherwise there is no further impact.

### 6.1.2.2.6 Benefits and drawbacks

#### **Benefits**

MBMS over TDD with "Integrated RAN scenario with Rel.6 FDD and TDD" supports high bit rate MBMS delivery without impacting the quality of on going dedicated services such as voice or data. The other benefits include:

- No impact on the core-network or BM-SC, in case the Rel.6 MBMS procedures are being used. For the case of the "one tunnel" approach, which is work in progress in SA2, it is required to make the necessary changes in [1].
- No additional procedures are required to support the MBMS service.
- Multicasting allows transmission of the MBMS multimedia only to the parts of the core network and UTRAN that have subscribers added to these particular multicast groups, therefore the load on the UTRAN/Core Network is reduced.
- More flexible charging models can be applied, compared to the case that the FDD and TDD RANs are not integrated.
- Allow efficient radio resource management as MBMS may be delivered over FDD p-t-p or TDD p-t-m bearers based on the number of UEs, which has activated the service.
- Allow fast switching (low service interruption) between MBMS delivery over TDD and FDD MBMS bearers. This is specially benefited in enabling service continuity at the edge of TDD coverage areas.

#### **Drawbacks**

- Some upgrade is required to the existing UTRAN-FDD network:
  - This is required for the Iur interface between FDD-RNC and TDD-RNC
  - Some functional upgrade is required at the FDD-RNC to trigger TDD-RNC linking over the Iur interface.
- Increase in UL loads in UTRAN-FDD due to cell update triggered by TDD cell change.
- Small increase in UL loads in UTRAN-FDD from cell update/ RRC connection due to the MBMS support in TDD.

## 6.1.2a LCR TDD + LCR TDD DL

### 6.1.2a.1 Scenario 1: TDD + TDD DL

#### 6.1.2a.1.1 Analysis of functions

In this scenario, from RAN's perspective, the Rel-7 TDD DL network operates separately. The Rel-7 TDD DL network need broadcast its system information in order to announce its specific MBMS ability and corresponding MBMS channel configurations. In addition, it is required for the Rel-7 TDD DL network to transmit MBMS control signaling over its MCCH for the MBMS services carried over Rel-7 TDD DL network.

This scenario does not preclude the cases where several Rel-7 TDD DL carriers are deployed separately with limited coordination among the MCCH control signalling for those Rel-7 TDD DL carriers. In those cases system information is separately transmitted over each Rel-7 TDD DL carrier. However, all the MCCH control signalling for those Rel-7 TDD DL carriers can be mixed in a coordination manner and repeatedly delivered over each Rel-7 TDD DL carrier. The detailed mechanism for that mix needs further study, while it may be desirable to merge the different part of MCCH control signalling for those Rel-7 TDD DL carriers, or to bring all services carried over those carriers into one common list for duplicated transmission. In case those Rel-7 TDD DL carriers are deployed with different coverage, it is desirable to transmit the coordinated MCCH control signalling over the Rel-7 TDD DL carrier with minimum radio coverage.

In this scenario, the service announcement related to the MBMS services delivered over the Rel-7 TDD DL carrier(s) could be broadcast to UEs onto the short time slot (as indicated in subclause 5.1.3) without establishment of a PDP context. Some modification inside application layer protocol may be needed in order to guarantee the integrity of service announcement received by UEs. However, the details of that modification are out of the scope of this study.

#### 6.1.2a.1.2 Specification impacts

The following modifications are required for RAN specifications in Rel-7 to support this scenario.

Physical layer support: Special timeslot structure and its relevant aspects are defined.

Cell selection/reselection: If operating in SFN mode, a MBMS SFN cluster instead of a cell will be targeted for UE selection/reselection.

BCCH information: Only SIB3, SIB5 and SIB11 applies to the standalone MBMS carrier and other Rel-6 SIBs are not applicable any more.

MBMS control signalling: Some MBMS control signaling in Rel-6 are simplified, since e.g. the neighbour cell information for combining is not needed.

#### 6.1.2a.1.3 Evaluation

Benefits:

- No impact to Rel-6 TDD services
- No upgrade required for core network

Drawbacks:

- Small enhancement of Rel-6 TDD RNC

#### 6.1.2a.2 Scenario 2: TDD + Multicarrier TDD DL

##### 6.1.2a.2.1 Analysis of functions

This scenario allows several Rel-7 TDD DL carriers to operate as a binding carrier cluster with several DL only carriers. For a cell supporting downlink carrier binding, the downlink common control signaling including BCCH, MICH, MCCH and MSCH can be only distributed on the preferred carrier within a carrier cluster. Other carriers in the carrier cluster are termed by secondary carriers, which are only used to transmit MBMS traffic without carrying common control signaling. The control signaling in preferred carriers takes the responsibility of the notification of the MBMS services in both preferred carriers and secondary carriers. For a binding carrier band, only the preferred carrier can act as the target for UE camping.

This scenario requires that all of the Rel-7 TDD DL carriers are deployed with same coverage as much as possible, otherwise it will lead to waste of spectrum resources.

##### 6.1.2a.2.2 Specification impacts

The following modifications are required for RAN specifications in Rel-7 to support the deployment scheme.

Physical layer support: Special subframe and its relevant aspects are defined.

Cell selection/reselection: Beacon channel is only configured in the preferred carrier, and only the preferred carrier acts as the target for cell selection/reselection on behalf of the whole carrier cluster.

BCCH information: Specific system information blocks are used to indicate the standalone spectrum and some Rel-6 SIBs are not applicable any more.

MBMS control signalling: Some MBMS control signaling in Rel-6 are simplified, since e.g. the neighbour cell information for combining is not needed.

RRM aspects: The RRM coordination among the carrier cluster is expected in order to improve the spectrum efficiency for delivery of MBMS services.

### 6.1.2a.2.3 Evaluation

Benefits:

- Be able to support high bit rate MBMS services
- No upgrade required for core network
- No impact to Rel-6 TDD services

Drawbacks:

- Small enhancement of Rel-6 TDD RNC
- Switching among different Rel-7 TDD DL carriers may result in lower frequency efficiency

## 6.1.2a.3 Scenario 3: TDD + Multicarrier TDD DL

### 6.1.2a.3.1 Analysis of functions

This scenario allows a Rel-6 TDD carrier and one or more Rel-7 TDD DL carriers to operate as a binding carrier cluster. In the binding carrier cluster it is necessary to associate a Rel-6 TDD cell with one or more cells supporting Rel-7 TDD DL only carrier. The downlink common control signaling including BCCH, MICH, MCCH and MSCH for multicarrier MBMS DL is only distributed on the associated Rel-6 TDD cell. The multicarrier MBMS DL network is only used to transmit MBMS traffic. The control signaling in associated Rel-6 TDD cell takes the responsibility of the notification of the MBMS services broadcast in the corresponding multicarrier MBMS DL cell. For a binding carrier band in this case, no DL carrier acts as the target for camping. UEs wishing to receive services from multicarrier MBMS DL cell should at the first step scan the associated Rel-6 TDD cell and read the associated control information for the services.

### 6.1.2a.3.2 Specification impacts

The following modifications are required for RAN specifications in Rel-7 to support the deployment scheme.

Physical layer support: Special subframe and its relevant aspects are defined.

Cell selection/reselection: In this scenario there is no configuration of beacon channel in Rel-7 TDD DL cell, the UE camps an associated Rel-6 TDD cell when receiving the traffic over Rel-7 TDD DL cell.

BCCH information: In this scenario, specific system information for standalone spectrum is combined with Rel-6 SIBs carried over an associated Rel-6 TDD cells.

MBMS control signalling: The MBMS control information for standalone spectrum is coupled in Rel-6 MBMS control information carried over MCCH of its associated Rel-6 TDD cells.

RRM aspects: The association between Rel-6 TDD cells and the Rel-7 TDD DL cells should be taken into account for system operation. Furthermore this association may trigger additional RRM coordination process between Rel-6 TDD cells and Rel-7 TDD DL cells.



### 6.1.2a.3.3 Evaluation

Benefits:

- Be able to support high bit rate MBMS services
- No upgrade required for core network
- No impact to Rel-6 TDD services
- Close coupling of Rel-6 TDD carrier and Rel-7 TDD DL carrier

Drawbacks:

- Small enhancement of Rel-6 TDD RNC
- Coordination between Rel-6 TDD cell and Rel-7 TDD DL may trigger additional RRM process

### 6.1.3 Interference considerations for simultaneous operation of unicast and MBMS auxiliary carrier

It is a potential scenario that the unicast service is supported over a paired carrier while MBMS is supported over an unpaired carrier. In this case, measures must be implemented such that out of band emissions from UL transmission do not cause significant interference to MBMS reception. If simultaneous operation is to be supported in the same device, the degree of interference caused depends on the proximity of the paired UL carrier to the unpaired carrier.

There are three proposed methods to resolve the issue of MBMS receiver desensitization:

- Solution 1: Allow a guard band between paired the UL carrier and the unpaired MBMS carrier
- Solution 2: Smart scheduling
- Solution 3: GSM fallback for MBMS dedicated frequency

#### 6.1.3.1 Solution 1: Allow a guard band between paired the UL carrier and the unpaired MBMS carrier

Simultaneous operation of a UE receiving an unpaired MBMS carrier co-located with a UE transmitting on an UL FDD carrier is possible with a guard band. The size of the guard band is dependent on the assumptions for UE to UE co-existence but a value of approximately 10 MHz would seem reasonable.

The feasibility of simultaneous reception of an unpaired MBMS carrier and transmission on an UL FDD carrier in the same UE platform is still being studied by RAN WG4. Aspects that are being considered are duplex filter requirements, antenna isolations, and expected Tx/Rx performance.

#### 6.1.3.2 Solution 2: Smart scheduling

Node-B schedules resources appropriately such that the UL is never transmitted by the UE at the same time as the MBMS signal is being received. i.e. avoid the simultaneous operation of transmission and reception at the UE via smart scheduling.

Note: Final analysis of the efficiency and the viability of this solution is still missing

#### 6.1.3.3 Solution 3: GSM fallback for MBMS dedicated frequency

A UE disables the use of the UMTS for unicast transmission and instead camps on a GSM cell during the reception of the MBMS service on the MBMS dedicated layer. The UE would in that case not be able to participate in counting, and therefore whether a UE is allowed to do so would depend on the MBMS service and / or needs to be network controlled. The important requirement to be able to perform speech calls, receive notifications and SMS, perform RA/LA update etc. is still satisfied in GSM. The network should be able to control whether it is allowed to disable the use of UMTS MBMS for unicast service during the reception of a MBMS service which would also impact the UEs capability to respond to counting.

Remaining uncertainties include:

- Signalling overhead due to LA / RA at reselection to / from GSM
- Overhead due to release of RRC connection for PCH state UEs transition to / from GSM

Note: Final analysis of the efficiency and the viability of this solution is still missing.

### 6.1.4 RF Aspects of Re-configuration of Rx diversity terminal to support two independent frequency layers

Some issues have been raised with regard to simultaneous reception in the UE of 2 carrier frequencies (also referred to as 'dual LO') in order to simultaneously receive a unicast carrier and a dedicated MBMS carrier. Further study is expected from RAN WG4 to further the understanding of these issues in order that appropriate system procedures and performance requirements can be derived in any ongoing work. Issues raised include:

- The need for each receiver path to have equivalent radiated (i.e. including antenna and subsystems) and conducted sensitivity and blocking performance requirements needs to be understood.
- The operation of two LOs at nearby frequencies (e.g. adjacent downlink carriers) presents challenges to avoid interaction of the LOs and thereby degradation of LO spurious performance.
- Simultaneous dual carrier frequency reception and transmission on unicast carrier may result in a different Tx-Rx separation for each of the receiver paths which could impact receiver sensitivity and blocking performance. This issue depends on passband bandwidths, centre frequencies and duplex spacing for the bands concerned.
- Potential size, cost, and current drain implications of an architecture that supports dual carrier frequency reception compared to one that supports only single carrier frequency reception.
- The loss of diversity gain if a 2 branch diversity receiver is reconfigured so that one branch is used for reception of the dedicated MBMS carrier and the other branch is used for reception of the unicast carrier.

## 6.2 SFN operation for MBMS

### 6.2.1 TD-CDMA - Time multiplexing of MBMS with unicast carrier

The common cell ID for 3.84Mcps TDD has been studied in RAN WG1 and a summary of the results obtained with realistic simulation assumptions are captured below. Existing release 6 MBMS for 3.84Mcps TDD can support approximately 20 x 64kbps channels at 95% coverage using 12 out of 15 timeslots [4]. This corresponds to a spectral efficiency of approximately 0.25 bps/Hz. From Table 2 below it can be seen that for a variety of simulation environments employing a common cell ID, with varying site-to-site distances, there is a considerable increase in throughput. For the same partition of the unicast and broadcast/multicast timeslots, i.e. 12 out of 15 for broadcast/multicast, the spectral efficiency is increased to 0.7 bps/Hz, i.e. nearly a three-fold improvement.

	Scenario I (case 1 LTE)	Scenario II (case 2 LTE)	Scenario III (case 3 LTE)	Scenario IV (TDD R6 MBMS)
Site-to-site distance	500m	2500m <sup>†</sup>	1732m	1000m
Timeslot throughput	290 kbps	290 kbps	290 kbps	290 kbps
Spectral efficiency (12/15 timeslots)	0.7 bps/Hz	0.7 bps/Hz	0.7 bps/Hz	0.7 bps/Hz

**Table 2. SFN S-CCPCH throughput at 95% coverage.**

<sup>†</sup> The site-to-site distance is increased from the LTE case 2 value of 500m.

It is found that the limiting factor in the timeslot throughput in the outlined results is the realistic maximum FEC code rate for the number of physical codes transmitted, i.e. the results presented in Table 2 are mainly code limited. To improve the performance further, the S-CCPCH physical resource can be expanded. This can be simply effected by allowing the use of 16QAM for the S-CCPCH. The throughputs for the same simulation scenarios with 16QAM are presented in Table 3. It is observed that by using 16QAM the timeslot throughput has increased further in all but one of the scenarios and that for the non-power limited scenarios of I and IV the timeslot throughput is approximately 500kbps

or better. For a similar partition of resources as previously presented this corresponds to spectral efficiencies of >1.1 bps/Hz, or in excess of a four-fold increase upon the release 6 MBMS values.

	Scenario I (case 1 LTE)	Scenario II (case 2 LTE)	Scenario III (case 3 LTE)	Scenario IV (TDD R6 MBMS)
Site-to-site distance	500m	2500m <sup>†</sup>	1732m	1000m
Timeslot throughput	590 kbps	348 kbps	265 kbps	497 kbps
Spectral efficiency (12/15 timeslots)	1.42 bps/Hz	0.83 bps/Hz	0.64 bps/Hz	1.19 bps/Hz

**Table 3. SFN S-CCPCH with 16QAM throughput at 95% coverage.**

<sup>†</sup> The site-to-site distance is increased from the LTE case 2 value of 500m.

### 6.2.1A 1.28 Mcps TDD - Time multiplexing of MBMS with unicast carrier

The common cell ID for 1.28 Mcps TDD has been studied in RAN WG1 and a summary of the respective results obtained with realistic simulation assumptions are captured below. Existing release 6 MBMS for 3.84 Mcps TDD can support approximately 2 x 64kbps channels at 95% coverage using 3 out of 6 time slots [4]. This corresponds to a spectral efficiency of approximately 0.08bps/Hz for 1.28 Mcps TDD. From Table 3a below it can be seen that for a variety of simulation environments employing a common cell ID, with varying site-to-site distances, there is a considerable increase in throughput. Simulations for the single scenario studied show a seven-fold increase compared to Rel-6 performance, i.e. 0.6bps/Hz.

	Scenario (LCR TDD R6 MBMS)
UE receiver diversity	None
Timeslot throughput	192 kbps
Spectral efficiency(5/7 timeslots)	0.6bps/Hz

**Table 3a. SFN S-CCPCH throughput at 95% coverage.**

It is found that the limiting factor in the timeslot throughput in the outlined results is the realistic maximum FEC code rate for the number of physical codes transmitted, i.e. the results presented in Table 3a are mainly code limited. To improve the performance further, the S-CCPCH physical resource can be expanded. This can be simply effected by allowing the use of 16QAM for the S-CCPCH. The throughputs for the same simulation scenarios with 16QAM are presented in Table 3b. It is observed that by using 16QAM the timeslot throughput shows a fifteen-fold increase compared to release 6 performance, i.e 1.2bps/Hz.

	Scenario (LCR TDD R6 MBMS)
UE receiver diversity	2 branches
Timeslot throughput	384kbps
Spectral efficiency (5/7 time slots)	1.2 bps/Hz

**Table 3b. SFN S-CCPCH with 16QAM throughput at 95% coverage.**

### 6.2.2 TD-CDMA - MBMS for auxiliary carrier

If a dedicated auxiliary carrier is used to deliver broadcast/multicast MBMS transmissions using a common cell ID, the proportion of TDD timeslots of the dedicated carrier that can carry the MTCH is increased. Assuming 1 timeslot for signalling then a total of 14 out of 15 timeslots of the auxiliary carrier maybe dedicated to broadcast/multicast MBMS channels. This leads to the spectral efficiency values presented in Table 4. It is observed that using a TDD auxiliary carrier to deliver broadcast/multicast MBMS channels via a common cell ID approach results in spectral efficiencies ranging between 0.81 and 1.65 bps/Hz for the variety of simulation environments studied.

	Scenario I (case 1 LTE)	Scenario II (case 2 LTE)	Scenario III (case 3 LTE)	Scenario IV (TDD R6 MBMS)
Site-to-site distance	500m	2500m <sup>†</sup>	1732m	1000m

Spectral efficiency QPSK (14/15 timeslots)	0.81 bps/Hz	0.81 bps/Hz	0.81 bps/Hz	0.81 bps/Hz
Spectral efficiency 16QAM (14/15 timeslots)	1.65 bps/Hz	0.97 bps/Hz	0.74 bps/Hz	1.39 bps/Hz

**Table 4. SFN S-CCPCH spectral efficiency with auxiliary carrier at 95% coverage.**

<sup>†</sup> The site-to-site distance is increased from the LTE case 2 value of 500m.

## 6.2.2A 1.28 Mcps TDD - MBMS for dedicated carrier

If a dedicated carrier is used to deliver broadcast/multicast MBMS transmissions using a common cell ID, the proportion of TDD timeslots of the dedicated carrier that can carry the MTCH is increased. Assuming the MBSFN Special timeslot for signalling then a total of 7 MBSFN Traffic timeslots of the carrier may be dedicated to broadcast/multicast MBMS channels. This leads to the spectral efficiency values presented in Table 4a.

	Scenario I	Scenario II
Site-to-site distance	1386m	2500m
Spectral efficiency QPSK (7 timeslots)	0.94 bps/Hz	0.90 bps/Hz
Spectral efficiency 16QAM (7 timeslots)	1.70bps/Hz	1.60 bps/Hz

**Table 4a. SFN S-CCPCH spectral efficiency with dedicated carrier at 95% coverage.**

## 6.2.3 MBMS dedicated carrier with SFN operations – Study 1 (FDD)

### 6.2.3.1 Simulation assumptions and physical channel conditions

System level simulation assumptions are stated in Table 5, considered power delay profile corresponds to a 3 km/h Vehicular A channel [4] and 90% of the transmit power is dedicated for MBMS and the remaining 10% transmit power for CPICH.

**Table 5: System level assumptions**

Parameter	Value
Cellular Layout	19 Hexagonal cells, 3-sector sites
Site to site distance	2800 m
Node-B antenna gain + cable loss	17 dBi
Antenna front-to-back ratio	28 dB
Horizontal antenna pattern	60 degrees (-3dB) beamwidth
Vertical antenna pattern loss	Not considered
Propagation model	Path loss = $128.1 + 37.6 \cdot \log(R)$
Standard deviation of slow fading	8.0 dB
Correlation b/w sites for slow fading	0.5
Node-B total transmit power	43 dBm
Thermal noise	-174 dBm/Hz
UE noise figure	9 dB
HHO hysteresis	3dB (only for Soft Combining)

For advanced receiver types, spectral efficiency might be limited by the availability of channelization codes. In order to fully utilize the available power for MBMS, combinations of different physical channel configurations may need to be considered. Below, S-CCPCH with three configurations is specified, in which all use 64 kbps information bit rate and 80 ms TTIs.

- Configuration 1: QPSK, SF = 32 (slot format #10) and coding rate 0.28.
- Configuration 2: QPSK, SF = 64 (slot format #8) and coding rate 0.594.

- Configuration 3: 16QAM, SF = 128 (as slot format #4) and coding rate 0.536.

Configuration 3 is the most code-space efficient, but also the least energy efficient.

### 6.2.3.2 Spectral efficiency

The combinations of the S-CCPCH configurations in subclause 6.2.3.1, maximizing the spectral efficiency for 95% coverage and 1% BLER, are summarized in Table 6 for the following receiver types:

- Rake
- Type-1
- Type-2
- Type-3

The performance of the receiver schemes operating in SFN mode are compared with release 6 soft combining [4] of three radio links. An implementation margin of 1.6 dB has been added in the simulations to model loss due to non-ideal channel estimation, transmitter and receiver impairments, etc. The achieved capacity and spectral efficiency are summarized in Table 7 and in Table 8. With 16QAM, the system can achieve up to 84 MBMS 64 kbps channels and spectral efficiency at 1.075 b/s/Hz, provided Type-3 receivers capable of equalizing 7 radio links are used. The spectral efficiency achieved by Type-2 receivers capable of equalizing 7 radio links is around 0.525 b/s/Hz. It can further be noticed that using two receive antennas doubles the spectral efficiency in general.

**Table 6: Best combinations of different configurations that maximize spectral efficiency (using 90% of the cell power).**

Receiver type, # of RLS, (SFN operation schemes or soft combining schemes)	# of channels for configuration 1	# of channels for configuration 2	# of channels for configuration 3
Rake, 3RLs	18	0	0
Type-2, 3RLs	19	0	0
Type-2, 3RLs (SFN)	24	0	0
Type-2, 7RLs (SFN)	22	19	0
Type-1, 3RLs	28	7	0
Type-3, 3RLs	26	11	0
Type-3, 3RLs (SFN)	16	31	0
Type-3, 7RLs (SFN)	0	43	41

**Table 7: MBMS capacity and spectrum efficiency achieved by SFN operation (using 90% of the cell power).**

Receiver	Receiver capable of equalizing 3 RLS	Receiver capable of equalizing 7 RLS
Type-2	1.536 Mbps	2.624 Mbps
	0.307 b/s/Hz	0.525 b/s/Hz
Type-3	3.008 Mbps	5.376 Mbps
	0.602 b/s/Hz	1.075 b/s/Hz

**Table 8: MBMS capacity and spectrum efficiency achieved by soft combining (using 90% of the cell power).**

Receiver	Receiver capable of soft combining 3 RLS
Rake	1.152 Mbps
	0.2304 b/s/Hz
Type-1	2.240 Mbps
	0.448 b/s/Hz
Type-2	1.216 Mbps
	0.2432 b/s/Hz
Type-3	2.368 Mbps
	0.4736 b/s/Hz

## 6.2.4 MBMS dedicated carrier with SFN operations – Study 2 (FDD)

### 6.2.4.1 Simulation assumptions and physical channel conditions

System level simulation assumptions correspond to the LTE Cases 1 and 3, with TU channel delay profile, and 90% of the transmit power is dedicated for MBMS and the remaining 10% for CPICH. The used transport block sizes (TBSs)

are defined in Table 9 and S-CCPCH slot format #10, with an 80ms TTI and a spreading factor of 32 along with an 8-bit TFCI are considered. For ease of simulation with higher order modulation, the turbo encoding chain of HS-DSCH is applied to the transport channels carried by S-CCPCH.

**Table 9: The TBS parameters used in the system simulations**

TBS	SF	Data symbols per slot per code	Data symbols per TTI per code (80 ms)	Bits per QAM Symbol	Data bits per TTI per code (80 ms)	Code rate	Information bits	Spectral Efficiency (bps/Hz)
1	32	76	9120	2	18240	0.3	5472	0.42
2	32	76	9120	2	18240	0.5	9120	0.71
3	32	76	9120	2	18240	0.7	12768	0.99
4	32	76	9120	2	18240	0.9	16416	1.27
5	32	76	9120	4	36480	0.3	10944	0.85
6	32	76	9120	4	36480	0.5	18240	1.41
7	32	76	9120	4	36480	0.7	25536	1.98
8	32	76	9120	4	36480	0.9	32832	2.54
9	32	76	9120	6	54720	0.3	16416	1.27
10	32	76	9120	6	54720	0.5	27360	2.12
11	32	76	9120	6	54720	0.7	38304	2.97
12	32	76	9120	6	54720	0.9	49248	3.82

### 6.2.4.2 Spectral efficiency

Figure 21 shows network simulation results, in which ICE indicates ideal channel estimation and PCE models practical channel estimation (AWGN added to ideal channel taps, with variance corresponding to 15 CPICH symbols sliding average window). The results are obtained for 30 chips per antenna LMMSE Type-2 and Type-3 receivers. Furthermore, transmitter and receiver impairments were modeled as a limit on the maximum achievable signal-to-noise ratio of 20 dB. The simulation results suggest that when considering ICE and Type-3 receiver, an area spectral efficiency at 95% coverage and 1% BLER is in the region of 0.6bps/Hz are achievable for the LTE Case 3 deployment scenario, and even greater area spectral efficiency – in excess of 2bps/Hz – are possible for LTE Case 1. However, it is noticed that the spectral efficiency degrades with channel estimation enabled, i.e. with PCE, possibly due to the limitation of the current CPICH structure.

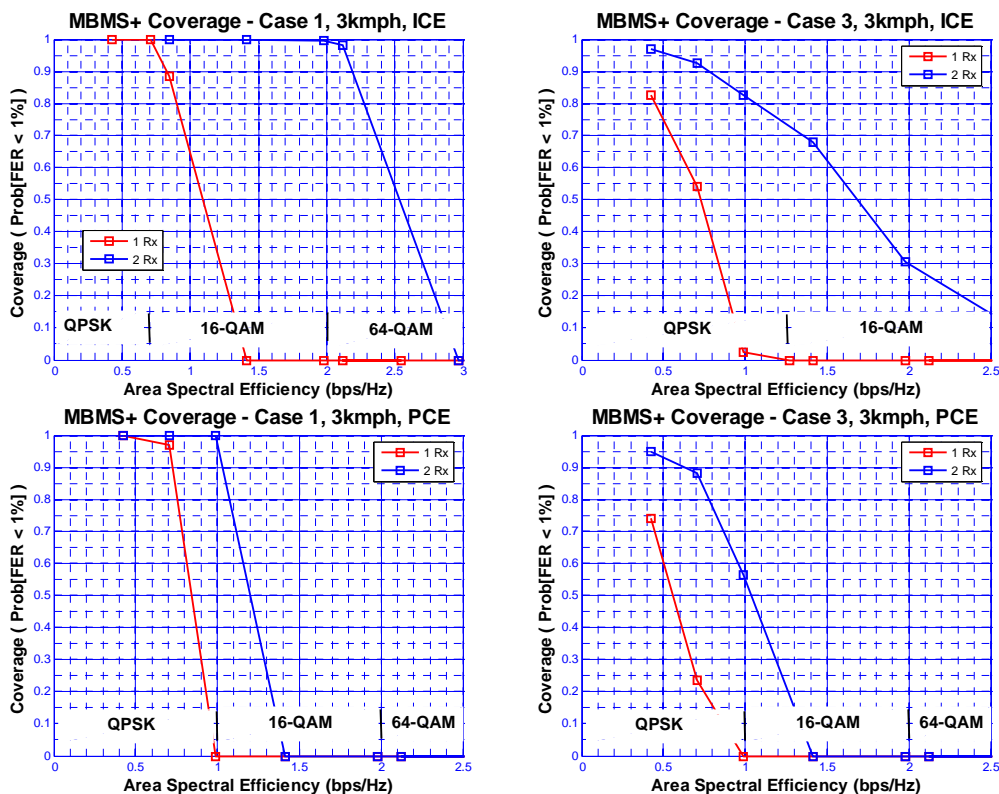

**Figure 21 Coverage vs. spectral efficiency**

---

## 7 Conclusions and Recommendations

### 7.1 Conclusions

#### 7.1.1 Dual receiver UEs

The study shows that three approaches i.e. FDD+WCDMA DL, FDD+TD-CDMA DL and LCR TDD+LCR TDD DL in subclauses 5.1 and 6.1 have lots of commonalities in terms of signalling and procedures, apart from frequency convergence scenarios in FDD+WCDMA DL.

#### 7.1.2 Network architecture considerations for separate MBMS carrier

For support of separate carrier MBMS deployment, two different scenarios have been identified and studied based on the level of interaction between the Radio Resource Management (RRM) of unicast operation and that of MBMS operation.

1. Non-integrated RAN scenario
2. Integrated RAN scenario.

The non-integrated scenario supposes an independent FDD / TDD MBMS DL only carrier overlaid on top of a carrier providing pre/post-Rel.6 FDD services. Counting would not be provided, hence this architecture would be more suitable for "mobile TV" like applications.

In order to provide service continuity at the edge of an MBMS DL only carrier coverage area, a number of solutions have been analysed for the non-integrated scenario. The applicability of these solutions depends on the capability of the underlying FDD unicast network.

The integrated deployment scenario requires interaction between MBMS network RRM and unicast network RRM at RAN level. This scenario not only provides MBMS service continuity at the edge of MBMS DL only carrier coverage, but may also allow for better radio resource utilization and efficient spectrum management according to service demand in MBMS DL only spectrum due to the fact that counting is supported.

For the case in which the Rel.6 MBMS procedures are used, the integrated scenario may be implemented without impact on the core network or BM-SC. However, for the case of the "one-tunnel" approach, this may need to be taken into account in the ongoing work in progress in SA2. Specifically for TDD the integrated approach may also allow for more flexible charging models to be applied compared to the non-integrated RAN scenario. For both TDD and FDD it may further allow for fast switching (low service interruption) between MBMS delivery over MBMS DL only carrier and FDD MBMS bearers. This is especially beneficial in enabling service continuity at the edge of MBMS DL only carrier coverage areas.

#### 7.1.3 SFN operation for MBMS

It was concluded at the joint RAN WG session in RAN1#47 and RAN2#56 that features in section 5.2 and 6.2 could be considered in a work item for improvements of MBMS in UTRAN.

The operation according to sections 5.2.1 and 6.2.1 does not require an auxiliary dedicated MBMS carrier and would represent a physical layer upgrade to the existing TDD Rel-6 MBMS.

## 7.2 Recommendations

It is recommended that 3GPP TSG RAN should consider the following principles in any new work item or items for improvement of MBMS in UTRAN. Simultaneous reception on different carriers is possible, but not mandated from the UEs. Further study from RAN4 is expected to better understand issues relating to simultaneous reception on different carriers.

Full mobility/paging etc. support should be provided by all UEs without mandating 2 LO, including operation on SFN.

This covers the following cases:

- Additional DL carrier without SFN
- Additional DL-only carrier with or without SFN
- Non DL-only carrier with SFN (TDD only)
- Additional binded DL-only carriers with or without SFN (LCR TDD only)
- Additional DL-only carriers with or without SFN binded with Non DL-only carrier (LCR TDD only)



## Annex A: Change history

Change history							
Date	TSG #	TSG Doc.	CR	Rev	Subject/Comment	Old	New
2006-05	RAN2#53	R2-061321			Proposed Skeleton TR		0.0.0
2006-08	RAN2#54	R2-062441			Updates after RAN2#53	0.0.0	0.0.1
2006-09	RAN2#54	R2-062673			Updates after RAN2#54	0.0.1	0.0.2
2006-09	RAN#33	RP-060604			TR version 0.0.2 was endorsed as TR version 1.0.0	0.0.2	1.0.0
2006-11	RAN2#56	R2-063643			Updates after the joint RAN WG session during RAN1#47 and RAN2#56	1.0.0	2.0.0
2006-11	RP-34	RP-060849			The TR was approved with removal of editor's notes.	2.0.0	2.1.0
	RP-34	-			Placed under change control	2.1.0	7.0.0
2007-06	RP-36	RP-070409	0001		1.28Mcps TDD MBMS physical layer improvements related changes	7.0.0	7.1.0
	RP-36	RP-070409	0002		Introduce MBMS LCR TDD Physical Layer Enhancement	7.0.0	7.1.0
2007-12	RP-38	RP-070902	0003		More improvement on Dedicated Carrier for 1.28Mcps TDD MBMS	7.1.0	7.2.0

---

## History

<b>Document history</b>		
V7.1.0	June 2007	Publication
V7.2.0	January 2008	Publication