

ETSI TR 123 973 V16.1.0 (2020-11)



TECHNICAL REPORT

**LTE;
5G;
User data interworking, coexistence and migration
(3GPP TR 23.973 version 16.1.0 Release 16)**



Reference

DTR/TSGS-0223973vg10

Keywords

5G,LTE

ETSI

650 Route des Lucioles
F-06921 Sophia Antipolis Cedex - FRANCE

Tel.: +33 4 92 94 42 00 Fax: +33 4 93 65 47 16

Siret N° 348 623 562 00017 - NAF 742 C
Association à but non lucratif enregistrée à la
Sous-Préfecture de Grasse (06) N° 7803/88

Important notice

The present document can be downloaded from:

<http://www.etsi.org/standards-search>

The present document may be made available in electronic versions and/or in print. The content of any electronic and/or print versions of the present document shall not be modified without the prior written authorization of ETSI. In case of any existing or perceived difference in contents between such versions and/or in print, the prevailing version of an ETSI deliverable is the one made publicly available in PDF format at www.etsi.org/deliver.

Users of the present document should be aware that the document may be subject to revision or change of status.

Information on the current status of this and other ETSI documents is available at

<https://portal.etsi.org/TB/ETSIDeliverableStatus.aspx>

If you find errors in the present document, please send your comment to one of the following services:

<https://portal.etsi.org/People/CommiteeSupportStaff.aspx>

Copyright Notification

No part may be reproduced or utilized in any form or by any means, electronic or mechanical, including photocopying and microfilm except as authorized by written permission of ETSI.

The content of the PDF version shall not be modified without the written authorization of ETSI.

The copyright and the foregoing restriction extend to reproduction in all media.

© ETSI 2020.

All rights reserved.

DECT™, **PLUGTESTS™**, **UMTS™** and the ETSI logo are trademarks of ETSI registered for the benefit of its Members.

3GPP™ and **LTE™** are trademarks of ETSI registered for the benefit of its Members and of the 3GPP Organizational Partners.

oneM2M™ logo is a trademark of ETSI registered for the benefit of its Members and of the oneM2M Partners.

GSM® and the GSM logo are trademarks registered and owned by the GSM Association.

Intellectual Property Rights

Essential patents

IPRs essential or potentially essential to normative deliverables may have been declared to ETSI. The information pertaining to these essential IPRs, if any, is publicly available for **ETSI members and non-members**, and can be found in ETSI SR 000 314: "*Intellectual Property Rights (IPRs); Essential, or potentially Essential, IPRs notified to ETSI in respect of ETSI standards*", which is available from the ETSI Secretariat. Latest updates are available on the ETSI Web server (<https://ipr.etsi.org/>).

Pursuant to the ETSI IPR Policy, no investigation, including IPR searches, has been carried out by ETSI. No guarantee can be given as to the existence of other IPRs not referenced in ETSI SR 000 314 (or the updates on the ETSI Web server) which are, or may be, or may become, essential to the present document.

Trademarks

The present document may include trademarks and/or tradenames which are asserted and/or registered by their owners. ETSI claims no ownership of these except for any which are indicated as being the property of ETSI, and conveys no right to use or reproduce any trademark and/or tradename. Mention of those trademarks in the present document does not constitute an endorsement by ETSI of products, services or organizations associated with those trademarks.

Legal Notice

This Technical Report (TR) has been produced by ETSI 3rd Generation Partnership Project (3GPP).

The present document may refer to technical specifications or reports using their 3GPP identities. These shall be interpreted as being references to the corresponding ETSI deliverables.

The cross reference between 3GPP and ETSI identities can be found under <http://webapp.etsi.org/key/queryform.asp>.

Modal verbs terminology

In the present document "**should**", "**should not**", "**may**", "**need not**", "**will**", "**will not**", "**can**" and "**cannot**" are to be interpreted as described in clause 3.2 of the [ETSI Drafting Rules](#) (Verbal forms for the expression of provisions).

"**must**" and "**must not**" are **NOT** allowed in ETSI deliverables except when used in direct citation.

Contents

Intellectual Property Rights	2
Legal Notice	2
Modal verbs terminology.....	2
Foreword.....	4
1 Scope	5
2 References	5
3 Definitions and abbreviations.....	6
3.1 Definitions	6
3.2 Abbreviations	6
4 Architectural Assumptions and Principles	7
4.1 Architectural Assumptions	7
4.2 Architectural Principles	7
5 Deployment Scenarios.....	7
6 Solutions.....	7
6.1 Solution #1: Direct SBA UDM-HSS Interworking.....	7
6.1.1 Introduction.....	7
6.1.2 High-level Description.....	7
6.1.3 Services and Illustrated Procedures	8
6.1.4 Impacts on existing services and interfaces	9
6.1.5 Evaluation	9
6.2 Solution #2: UDM/HSS FE interaction reusing legacy protocol.....	9
6.2.1 Introduction.....	9
6.2.2 High-level Description.....	9
6.2.2.1 Authentication and Registration.....	9
6.2.2.2 IP address continuity of interworking without N26 from 5GS to EPS.....	10
6.2.2.3 T-ADS for IMS voice.....	11
6.2.2.4 Supporting IMS related procedures.....	12
6.2.2.5 SMS over NAS.....	13
6.2.3 Services and Illustrated Procedures	14
6.2.3.1 Authentication and Registration.....	14
6.2.3.2 IP address continuity of interworking without N26 from 5GS to EPS.....	16
6.2.3.3 T-ADS for IMS voice.....	17
6.2.3.4 Supporting IMS related procedures.....	18
6.2.3.5 SMSF address storage and retrieval	19
6.2.3.6 MT SMS domain selection.....	19
6.2.4 Impacts on existing services and interfaces	21
6.2.4.1 Authentication impacts.....	21
6.2.4.2 IP address continuity impacts.....	21
6.2.4.3 T-ADS for voice impacts	22
6.2.4.4 Supporting IMS related procedures.....	22
6.2.5 Evaluation	22
6.3 Solution #3: Deployment and coexistence without interworking between UDM and existing HSS.....	22
6.3.1 Introduction.....	22
6.3.2 High-level Description.....	22
6.3.3 Services and Illustrated Procedures	27
6.3.4 Impacts on existing services and interfaces	28
6.3.5 Evaluation	28
7 Conclusions	28
Annex A: Change history	29
History	30

Foreword

This Technical Report has been produced by the 3rd Generation Partnership Project (3GPP).

The contents of the present document are subject to continuing work within the TSG and may change following formal TSG approval. Should the TSG modify the contents of the present document, it will be re-released by the TSG with an identifying change of release date and an increase in version number as follows:

Version x.y.z

where:

- x the first digit:
 - 1 presented to TSG for information;
 - 2 presented to TSG for approval;
 - 3 or greater indicates TSG approved document under change control.
- y the second digit is incremented for all changes of substance, i.e. technical enhancements, corrections, updates, etc.
- z the third digit is incremented when editorial only changes have been incorporated in the document.

Introduction

During the network migration to 5GC, it is possible for operators to deploy separate HSS and UDM/UDR in e.g. multi-vendor scenario. This document describes the scenarios of separate UDM and HSS with separate repositories and with a common repository, and provides the corresponding solutions for these scenarios.

1 Scope

This Technical Report describes scenarios for co-existence of subscription data pertaining to legacy system (EPS) with data pertaining to the 5G system, when the HSS+UDM defined in Rel-15 is separated and both UDM and HSS are independent, and provides solutions to support this deployment where necessary.

NOTE 1: The subscription data referred to by this Technical Report comprises both static as well as dynamic data, including IMS, LCS, SMS data.

This technical report includes:

- diverse scenarios related to the storage of subscription data including, but not limited to, those of common repository for subscription data from EPS and 5GS, as well as separate repositories for EPS and 5GS subscription data; and
- the solutions supporting relevant procedures in TS 23.502 [2] (for e.g. authentication, mobility, handover and procedures for IMS and SMS handling in interworking between 5G system and EPS),

Provisioning aspects are out of the scope of this document.

Direct interactions between the EPS UDR and the 5GS UDR are out of the scope of this document.

2 References

The following documents contain provisions which, through reference in this text, constitute provisions of the present document.

- References are either specific (identified by date of publication, edition number, version number, etc.) or non-specific.
- For a specific reference, subsequent revisions do not apply.
- For a non-specific reference, the latest version applies. In the case of a reference to a 3GPP document (including a GSM document), a non-specific reference implicitly refers to the latest version of that document *in the same Release as the present document*.

- [1] 3GPP TR 21.905: "Vocabulary for 3GPP Specifications".
- [2] 3GPP TS 23.502: "Procedures for the 5G System".
- [3] 3GPP TS 23.335: "User Data Convergence (UDC); Technical realization and information flows; Stage 2".
- [4] 3GPP TS 29.335: "User Data Convergence (UDC); User data repository access protocol over the Ud interface; Stage 3".
- [5] 3GPP TS 23.002: "Network architecture".
- [6] 3GPP TS 23.501: "System Architecture for the 5G System".
- [7] 3GPP TS 23.228: "IP Multimedia Subsystem".
- [8] 3GPP TS 23.380: "IMS Restoration Procedures".
- [9] 3GPP TS 29.505: "5G System; Usage of the Unified Data Repository services for Subscription Data".
- [10] 3GPP TS 29.228: "IP Multimedia (IM) Subsystem Cx and Dx Interfaces; Signalling flows and message contents".
- [11] 3GPP TS 29.328: "IP Multimedia (IM) Subsystem Sh interface; Signalling flows and message contents".

- [12] 3GPP TS 33.501: "Security architecture and procedures for 5G System".
- [13] 3GPP TS 33.401: "System Architecture Evolution (SAE) - Security architecture".
- [14] 3GPP TS 23.794: "Study on Enhanced IMS to 5GC Integration".
- [15] 3GPP TS 23.060: "General Packet Radio Service (GPRS); Service description; Stage 2".
- [16] 3GPP TS 23.401: "General Packet Radio Service (GPRS) enhancements for Evolved Universal Terrestrial Radio Access Network (E-UTRAN) access".
- [17] 3GPP TS 24.229: "IP multimedia call control protocol based on Session Initiation Protocol (SIP) and Session Description Protocol (SDP); Stage 3".
- [18] 3GPP TS 29.214: "Policy and charging control over Rx reference point".
- [19] 3GPP TS 23.632: "User data interworking, coexistence and migration; Stage 2".
- [20] 3GPP TS 29.563: "5G System (5GS); Home Subscriber Server (HSS) services for interworking with Unified Data Management (UDM); Stage 3".
- [21] 3GPP TS 23.040: "Technical realization of the Short Message Service (SMS)".
- [22] 3GPP TS 23.204: "Support of SMS over generic 3GPP IP access; Stage 2".
- [23] 3GPP TS 29.272: "Mobility Management Entity (MME) and Serving GPRS Support Node (SGSN) related interfaces based on Diameter protocol".

3 Definitions and abbreviations

3.1 Definitions

For the purposes of the present document, the terms and definitions given in TR 21.905 [1] and the following apply. A term defined in the present document takes precedence over the definition of the same term, if any, in TR 21.905 [1].

5G Repository: Repository hosting subscription data for 5G UEs.

5GS UDR: term used to identify the Unified Data Repository defined in TS 23.501 [6] (clause 4.2.5).

EPS UDR: term used to identify the User Data Repository defined in TS 23.335 [3] (clause 4.2.3).

3.2 Abbreviations

For the purposes of the present document, the abbreviations given in TR 21.905 [1] and the following apply. An abbreviation defined in the present document takes precedence over the definition of the same abbreviation, if any, in TR 21.905 [1].

5GC	5G Core
5GS	5G System
5GS UDR	5G Unified Data Repository
HSS FE	Home Subscriber Server Front End
EPS	Enhanced Packet core System
EPS UDR	EPS User Data Repository
E-UTRAN	Evolved Universal mobile telecommunications system Terrestrial Radio Access Network
UDM	Unified Data Management

4 Architectural Assumptions and Principles

4.1 Architectural Assumptions

The 5GS data storage architecture defined in TS 23.501 [6], for structured data, is used as the baseline network architecture.

The User Data Convergence concept specified in TS 23.335 [3], is used for reference to EPS/legacy system architecture for data storage, when layered architecture is deployed (i.e. application front-end decoupled from data repository using the standard interface Ud defined in TS 29.335 [4]).

The Home Subscriber Server (HSS) architecture specified in clause 4.1.1 of TS 23.002 [5], is used for reference to EPS/legacy system architecture for data storage, when non-layered HSS architecture is deployed (i.e. monolithic deployment where user data are stored within the entity itself (or in an external entity via non-standard interfaces)).

4.2 Architectural Principles

In the UDC concept used for reference, HSS FE and EPS UDR defined in TS 23.335 [3] are assumed to interact for any data required by the study: no standardization will be considered for the interface between HSS FE and EPS UDR.

5 Deployment Scenarios

This document supports the following deployment scenarios:

Scenario 1: the HSS FE and UDM are separately deployed and the user data of 5GC, EPC, CS and IMS domains are also stored separately in different repositories (i.e. EPS UDR storing user data for EPC, CS and IMS domains, and 5GC UDR storing user data for 5GS domain). It is assumed that the HSS is deployed using the UDC architecture in TS 23.335 [3].

Scenario 2: a common repository (acting as EPS UDR and 5GS UDR) is shared between separate HSS and UDM, in which both the user data for 5GC, EPC, CS and IMS domains are stored. It is also assumed that the HSS is deployed using the UDC architecture in TS 23.335 [3].

6 Solutions

6.1 Solution #1: Direct SBA UDM-HSS Interworking

6.1.1 Introduction

This solution applies to deployment scenario 1 and 2.

This solution proposes a new Service Based Interface between UDM and HSS.

6.1.2 High-level Description

This contribution proposes a service based interface between HSS and UDM. The architecture for this solution is outlined in the following figure:

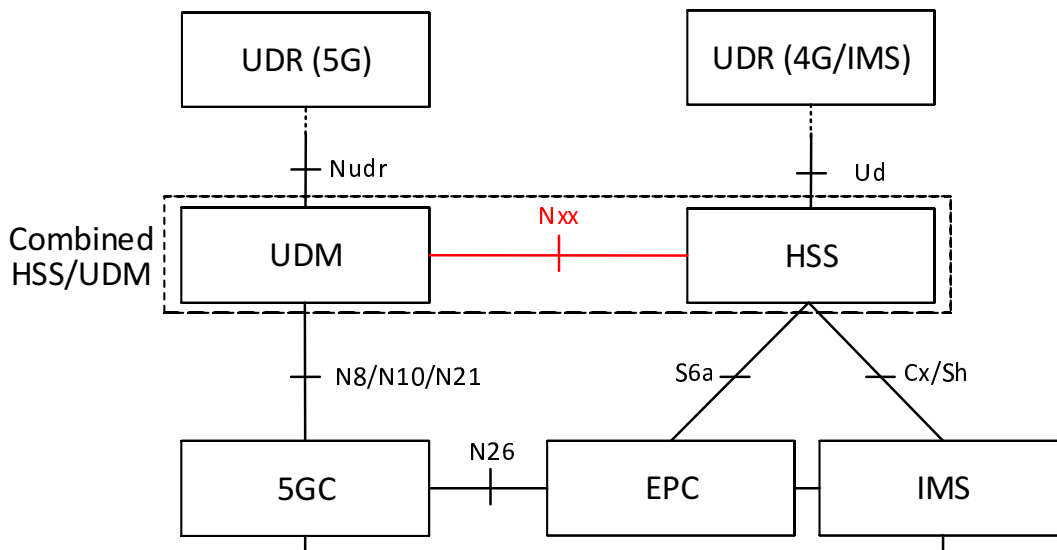

Figure 6.1.2-1: Architecture for Direct UDM-HSS Interworking with independent UDRs

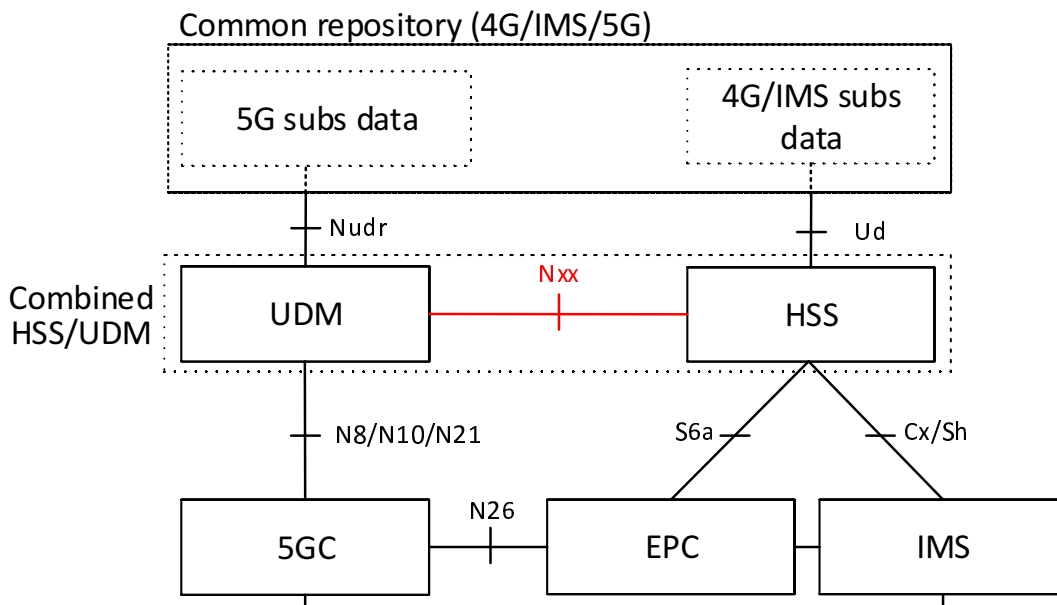

Figure 6.1.2-2: Architecture for Direct UDM-HSS Interworking with a common repository

A new reference point between UDM and HSS within the combined HSS/UDM (i.e. Nxx as depicted in Figures 6.1.2-1 and 6.1.2-2) is proposed. The new interface for interworking between HSS and UDM is proposed to be based on SBI principles.

NOTE: The UDM and the HSS may be deployed in a stand-alone manner and could be from different vendors.

6.1.3 Services and Illustrated Procedures

The Procedures and protocols for the Nxx interface are documented in TS 23.632 [19] and TS 29.563 [20] respectively.

Editor's note: The correct references need to be added when available. Nxx name may also need update.

6.1.4 Impacts on existing services and interfaces

Following impacts are identified:

a) Impacts in HSS:

New SBA service as documented in TS 23.632 [19] and TS 29.563 [20] respectively.

This SBA service has to follow registration/discovery/selection procedures (by means of interaction with NRF or by configuration) as defined for Rel-15 or its evolution/adaptation to Rel-16.

No impacts to existing interfaces or procedures.

b) Impacts in UDM

New SBA service as documented in documented in TS 23.632 [19] and TS 29.563 [20] respectively.

6.1.5 Evaluation

This solution identifies an approach that can work for both layered and not layered architectures of HSS.

In addition, it supports all the procedures that have been defined on EPS and 5GS without any impact on any other interface than the one between HSS and UDM this solution defines.

6.2 Solution #2: UDM/HSS FE interaction reusing legacy protocol

6.2.1 Introduction

This solution applies to deployment scenario 1 and 2.

The assumption of this solution is that 5GS UDR and EPS UDR are separate, between which there is no interface for direct interactions. The EPS and IMS profiles are stored in EPS UDR and the 5GS profile is stored in 5GS UDR.

UDM and HSS FE interacts to retrieve or update the required user data for the following procedures:

- Authentication procedure, i.e. initial attach/registration.
- Network Provided Location Information (NPLI).
- Procedure on IP address continuity of interworking without N26 from 5GS to EPS.
- T-ADS query for IMS voice.
- IMS related procedures related to Cx/Dx and Sh interfaces.
- SMS over NAS.

To avoid the impact on legacy HSS, the interactions for retrieving or updating user data are initiated by UDM through reusing existing HSS supported protocol and procedures, i.e. this solution only requires UDM to retrieve or update user data stored in EPS UDR via HSS FE. The interface between HSS FE and EPS UDR is also not impacted.

6.2.2 High-level Description

6.2.2.1 Authentication and Registration

A new interface, Shu, between UDM and HSS FE is introduced, by which UDM initiates interactions with HSS FE to retrieve or update user data stored in EPS UDR. Shu is a Point-to-Point reference point.

UDM is the only access point both to 5GC and EPC.

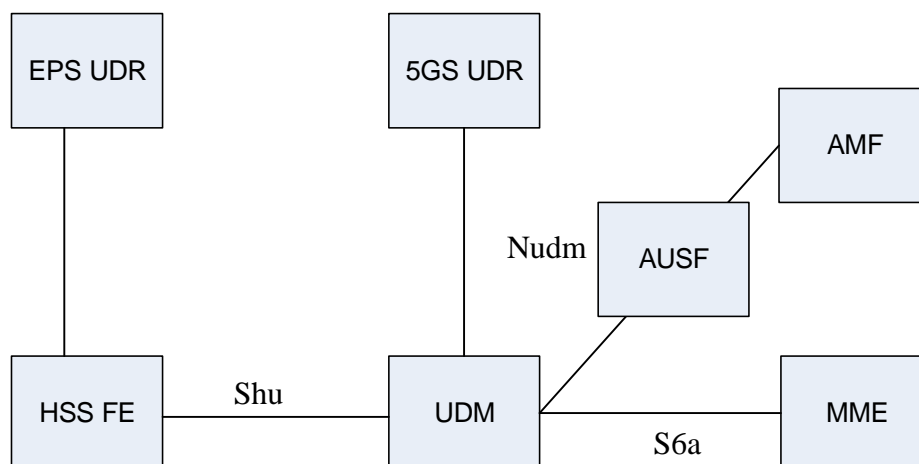

Figure 6.2.2.1.1: Solution architecture

In some 5G deployment, when a 4G subscriber is updated to 5G subscriber, the 4G subscription profile keeps stored in EPS UDR while the new 5G subscription data is provisioned in 5GS UDR. In this case it is assumed that the authentication data is only stored in EPS UDR and is reused by 5GS authentication.

For new 5G subscriber, all the subscription data is stored in 5GS UDR. Therefore, the solution described in this clause does not apply.

In this scenario, when a UE with 5GS subscription registers on 5GS, the UDM needs to interact with HSS FE to retrieve authentication vector(s) generated in EPS UDR.

NOTE 1: The UDM is a combo node which simultaneously supports UDM and HSS FE functionality.

NOTE 2: The authentication vector(s) can be authentication vector(s) for SGSN, which is 5 tuple vector that UDM can convert it into 5GC authentication vector(s) by implementation to avoid impact on HSS.

In the case of single registration in 5G, in order to cancel the registration in the other RAT, the UDM supports to perform a fake 4G registration in the HSS, as shown in Figure 6.2.3.1-2. This trigger the HSS to cancel the 4G registration. When the UE moves back to 4G, the HSS sends cancel location to UDM which trigger the UDM to deregister the UE in 5G.

6.2.2.2 IP address continuity of interworking without N26 from 5GS to EPS

Shu interface defined in clause 6.2.2.1 is reused.

UDM is the only access point both to 5GC and EPC.

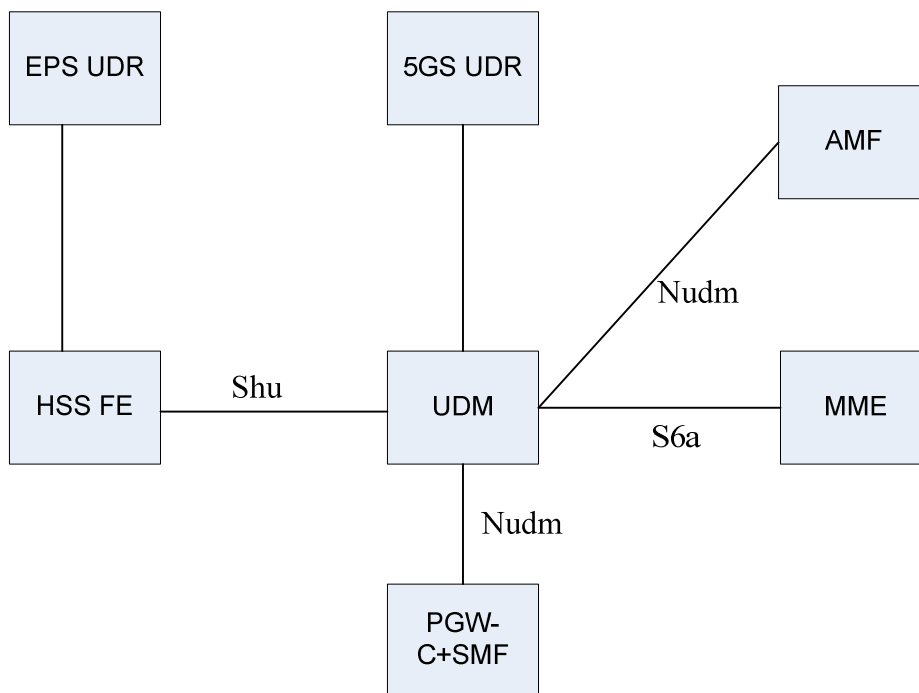

Figure 6.2.2.2-1: Solution architecture

When a UE initially registers in 5GC, the FQDN for the S5/S8 interface of the PGW-C+SMF is registered into UDM via Nudm as specified in clause 4.11.2 of TS 23.502 [2].

When UE attaches in EPS due to interworking without N26, the procedure specified in clause 4.11.2 of TS 23.502 [2] applies. When MME sends Update Location Request to UDM, after forwarding the request to HSS FE, UDM needs to retrieve the stored PGW-C+SMF FQDN and add it into the Update Location Ack message returned from HSS FE.

The MME use PGW-C+SMF FQDN received from the Update Location Ack message to determine the address of PGW-C+SMF.

6.2.2.3 T-ADS for IMS voice

Shu interface defined in clause 6.2.2.1 is reused.

UDM is the only access point both to 5GC, EPC and IMS, i.e. UDM supports S6a and Sh interfaces along with Nudm.

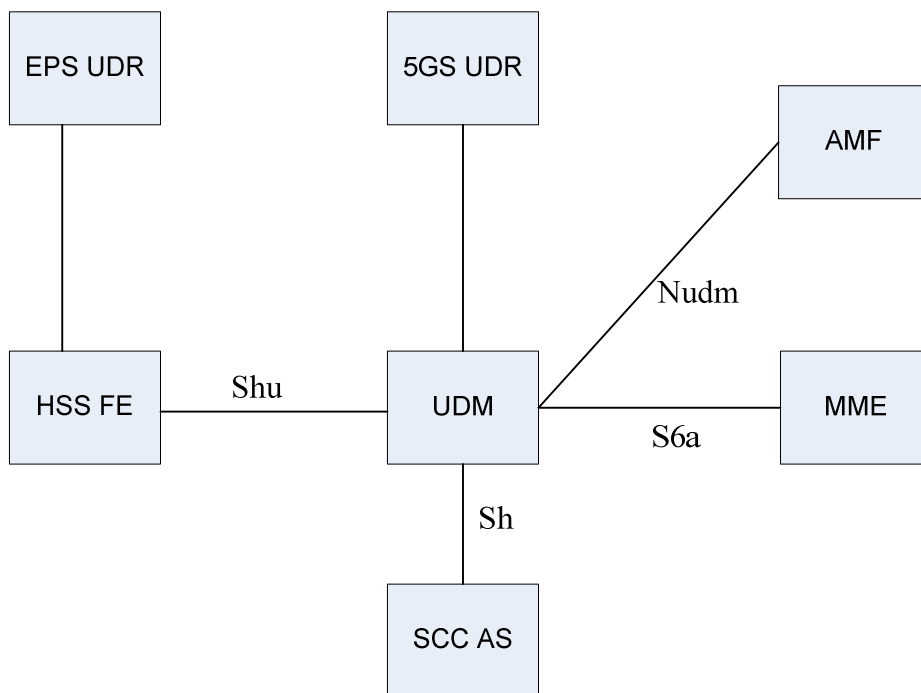

Figure 6.2.2.3-1: Solution architecture

SCC AS initiates T-ADS query towards UDM via Sh interface as specified in TS 29.328 [11].

To handle T-ADS query, the UDM queries T-ADS information towards HSS FE to get T-ADS information related to EPS and UMTS. HSS FE may query MME and SGSN to get information as specified in TS 23.401 [16] and TS 23.060 [15].

After receiving response of T-ADS query from HSS FE, UDM responds T-ADS query to SCC AS based on the T-ADS information received from HSS FE and T-ADS information in UDM. UDM may query AMF to get necessary information as specified in TS 23.501 [6].

6.2.2.4 Supporting IMS related procedures

Shu interface defined in clause 6.2.2.1 is reused.

UDM, which is a combo node supporting UDM and HSS functionalities, is the only access point both to 5GC, EPC and IMS.

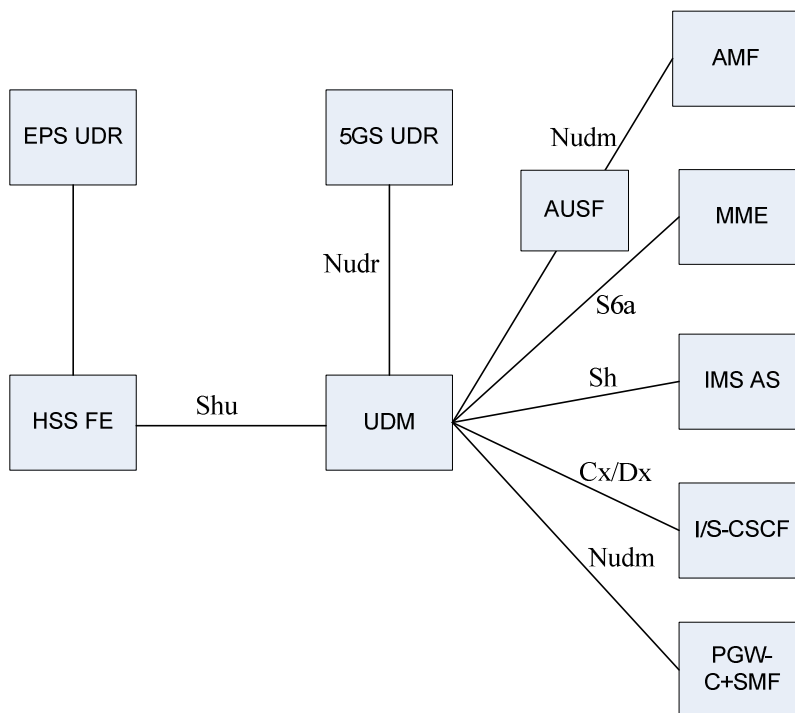

Figure 6.2.2.4-1: Solution architecture

Since IMS profile is stored in EPS UDR, the UDM needs to forward all the requests received from IMS via Cx/Dx or Sh interfaces to HSS FE to handle, and further forwards all the responses from HSS FE to IMS.

For some scenarios that HSS FE and EPS UDR may generate requests to IMS, the UDM needs to forward all the requests received from HSS FE to IMS via Cx/Dx or Sh interfaces to handle, and further forwards all the responses from IMS to HSS FE.

6.2.2.5 SMS over NAS

Shu interface defined in clause 6.2.2.1 is reused.

UDM is the only access point both to SMSF, SMS router and SMSC/SM GMSC.

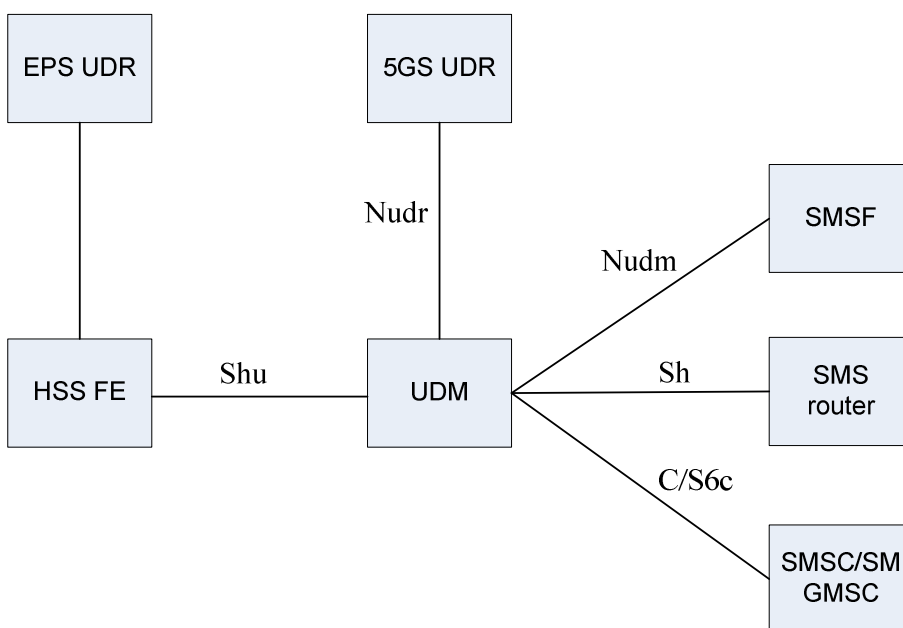

Figure 6.2.2.5-1: Solution architecture

6.2.3 Services and Illustrated Procedures

6.2.3.1 Authentication and Registration

The procedure of the interaction between UDM and HSS FE for Authentication vector(s) Retrieval is shown in Figure 6.2.3.1-1.

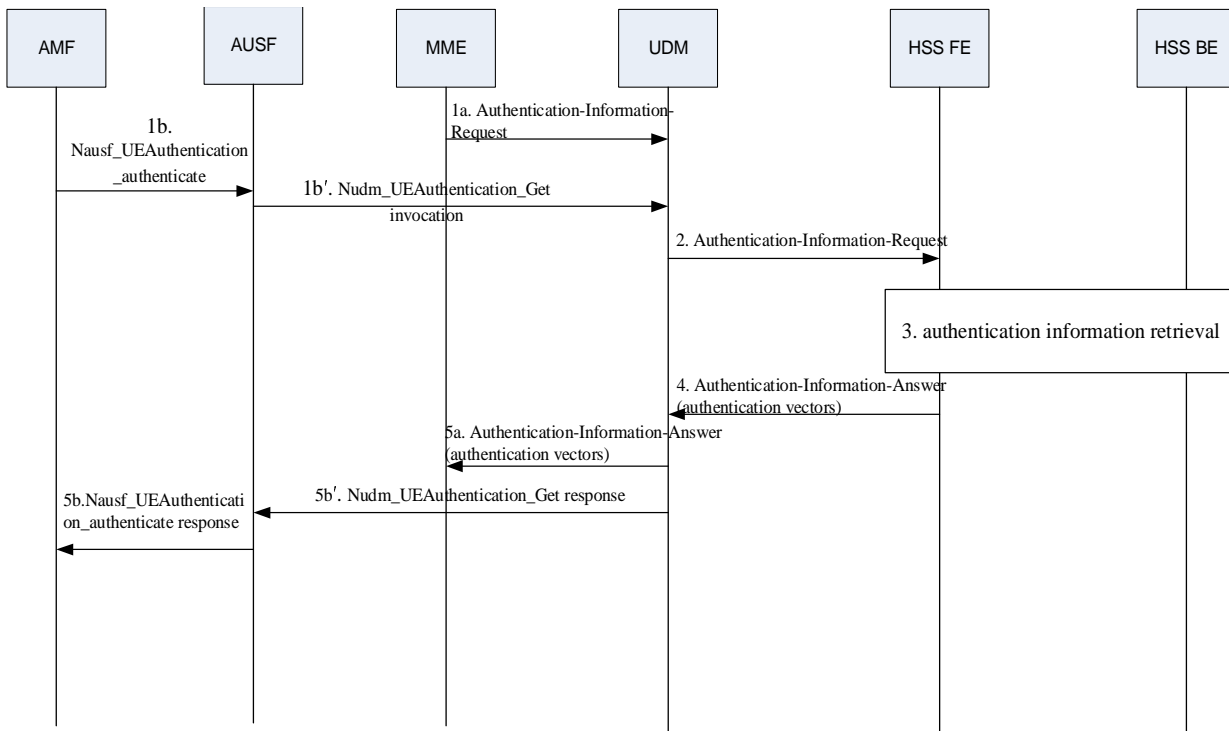

Figure 6.2.3.1-1: Authentication vectors Retrieval Procedure between UDM and HSS FE

- 1a. When the UE attaches from EPS, MME sends Authentication-Information-Request to UDM to get authentication information for the UE. The MME message is sent to UDM by DRA routing (i.e. based on IMSI range).
- 1b. When the UE registers from 5GS, AMF invokes Nausf_UEAuthentication_authenticate service operation to AUSF to get authentication information for the UE.
- 1b'. AUSF invokes Nudm_UEAuthentication_Get service operation.
2. When UDM receives Nudm_UEAuthentication_Get, it determines to generate and send S6a Authentication-Information-Request message to HSS-FE based on local configuration, to retrieve UTRAN authentication vectors, if the authentication information is stored in EPS UDR due to operator's deployment.
3. HSS FE interacts with EPS UDR to retrieve requested type of authentication information of the UE via legacy UDC architecture.
4. HSS FE returns Authentication-Information-Answer with E-UTRAN authentication vectors or UTRAN authentication vectors to UDM.
5. if MAP_SEND_AUTHENTICATION_INFO response is received, UDM converts CS or PS authentication vectors to 5GS authentication vectors.
- 5a. UDM forwards Authentication-Information-Answer with E-UTRAN authentication vectors to MME.

5b'. If UTRAN authentication vectors are received, UDM generates the respond to Nudm_UEAuthentication_Get service operation invocation with 5GS authentication vectors converted from UTRAN authentication vectors, and sends the respond to AUSF.

5b. AUSF response the AMF invoked Nausf_UEAuthentication_authenticate service.

NOTE: How UDM converts authentication vector is implementation specific.

The procedure of the interaction between UDM and HSS FE for single Registration is shown in Figure 6.2.3.1-1.

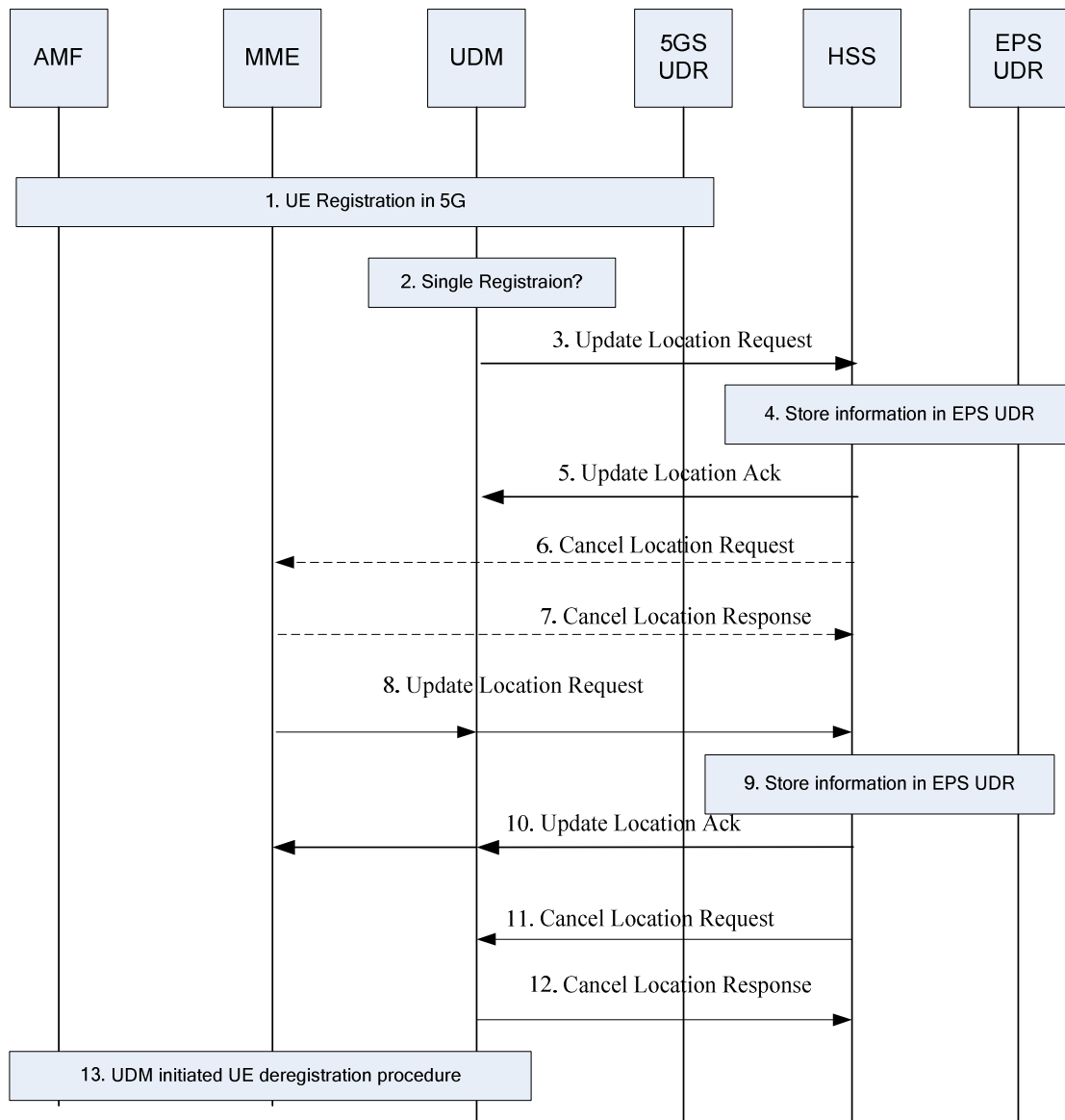

Figure 6.2.3.1-2: Single Registration Procedure between UDM and HSS FE

1. The UE is registered in 5G. The AMF perform UE registration in UDM. The AMF indicates whether it requires single registration or dual registration.
2. If the AMF requires single registration then the following steps are performed. Otherwise the procedure stops.
3. The UDM selects the HSS FE based on the SUPI and sends Update Location Request to HSS FE. In this message a dedicated MME Identity is included. This dedicated MME Identity is pointing to the UDM. From HSS FE point of view, the UDM is now acted as a MME. This message also includes an indication to indicate single registration and an indication to indicate the skip of subscription data so the HSS FE will not send the UE 4G subscription data.
4. The HSS FE stores the dedicated MME Identity into EPS UDR via Ud interface.

5. The HSS FE sends Update Location Response to UDM.
6. If the UE has been registered in an old MME, the HSS FE sends Cancel Location Request towards this old MME. This message will be routed to MME directly based on the old MME Identity.
7. The old MME deregisters the UE and sends Cancel Location Response to the HSS FE.
8. After the UE reselects 4G and performs Tracking Area Update procedure in 4G, the new MME sends Update Location Request towards the HSS FE. As the UDM is the only access point both to 5GC and EPC, this message is sent to UDM and the UDM relays this message to HSS FE.
9. The HSS stores the new MME information into EPS UDR via Ud interface.
10. The HSS sends Update Location Response to new MME via UDM including the UE 4G subscription.
11. Because the UE has been registered in 5G and a dedicated MME Identity pointing to the UDM is stored in the EPS UDR, the EPS UDR triggers the HSS FE to send Cancel Location Request towards the UDM. This message will be routed to UDM based on the dedicated MME Identity.
12. UDM sends Cancel Location Response to HSS FE.
13. Upon receiving Cancel Location Request from HSS FE targeting to deregister the UE in 5G, the UDM initiated Deregistration procedure to deregister the UE in 5G.

6.2.3.2 IP address continuity of interworking without N26 from 5GS to EPS

The procedure of the interaction between UDM and HSS FE is shown in Figure 6.2.3.2-1.

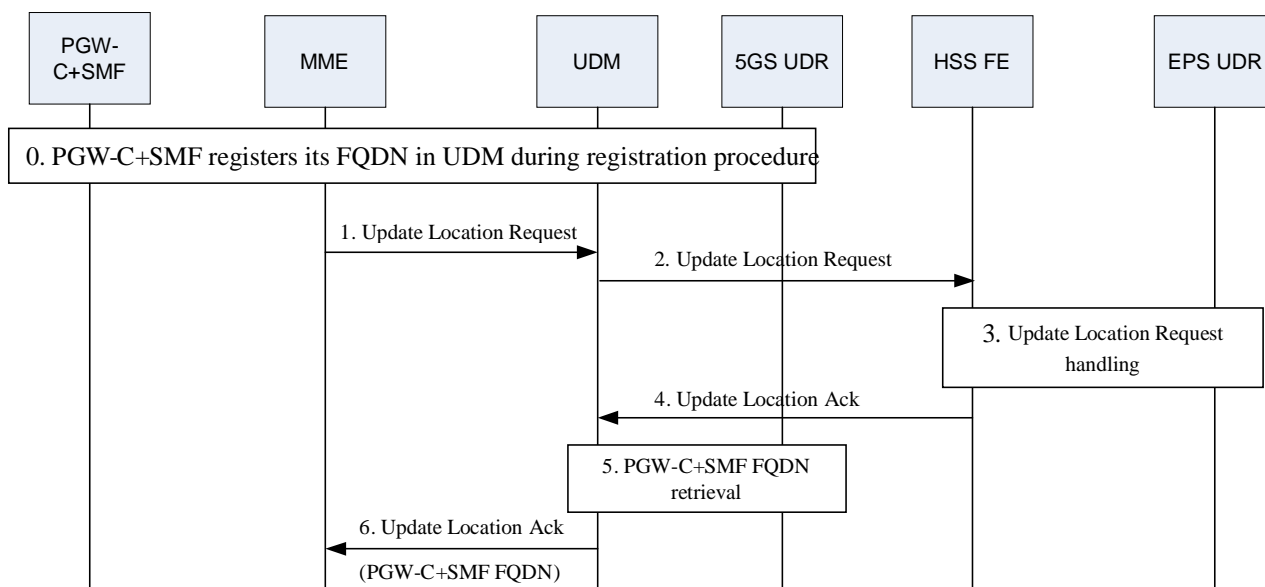

Figure 6.2.3.2-1: IP continuity procedure for interworking without N26 from 5GS to EPS

0. PGW-C+SMF registers its FQDN in UDM during registration procedure. UDM stores the FQDN in 5GS UDR.
1. When the UE attaches in EPS due to interworking without N26 from 5GS to EPS, during the procedure, MME sends Update Location Request to UDM.
2. UDM forwards Update Location Request to HSS FE for further handling.
3. HSS FE interacts with EPS UDR to handle Update Location Request.
4. HSS FE returns Update Location Ack to UDM.
5. after receiving Update Location Ack, UDM retrieve PGW-C+SMF FQDN from 5GS UDR.

- UDM generates a new Update Location Ack to add PGW-C+SMF FQDN into the message and forwards the message to MME.

NOTE: The other signalling interactions not related to the solution are not present in this figure for simplification.

6.2.3.3 T-ADS for IMS voice

The procedure of the interaction between UDM and HSS FE is shown in Figure 6.2.3.3-1.

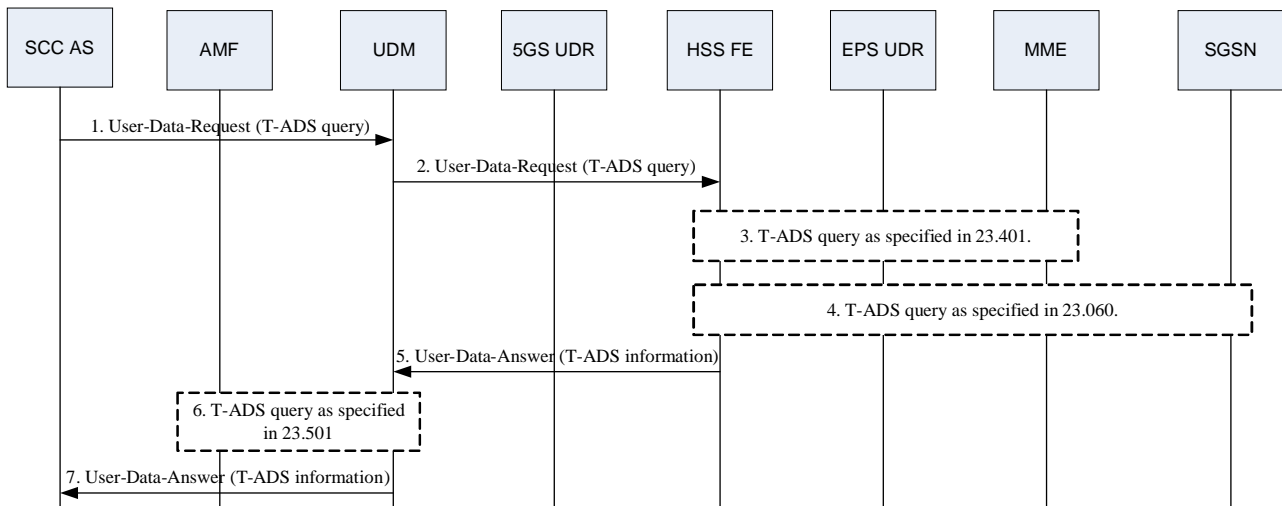

Figure 6.2.3.3-1: T-ADS Procedure between UDM and HSS FE

- SCC AS initiates T-ADS query towards UDM by sending a User-Data-Request message via Sh interface.
- UDM forwards this User-Data-Request message to get T-ADS information related to EPS and UMTS.
- HSS FE may query MME to get more T-ADS information as specified in TS 23.401 [16].
- HSS FE may query SGSN to get more T-ADS information as specified in TS 23.060 [15].
- HSS FE returns T-ADS information based on the information it derives by sending a User-Data-Answer message.
- after receiving T-ADS information from HSS FE, UDM may query AMF for more T-ADS information as specified in TS 23.501 [6].
- UDM determines T-ADS result based on T-ADS information received from HSS FE and AMF and responds to SCC AS with the T-ADS information by sending a User-Data-Answer message.

NOTE: The other signalling interactions not related to the solution are not present in this figure for simplification.

For the single registration case the following message flow in figure 6.2.3.3-2 applies:

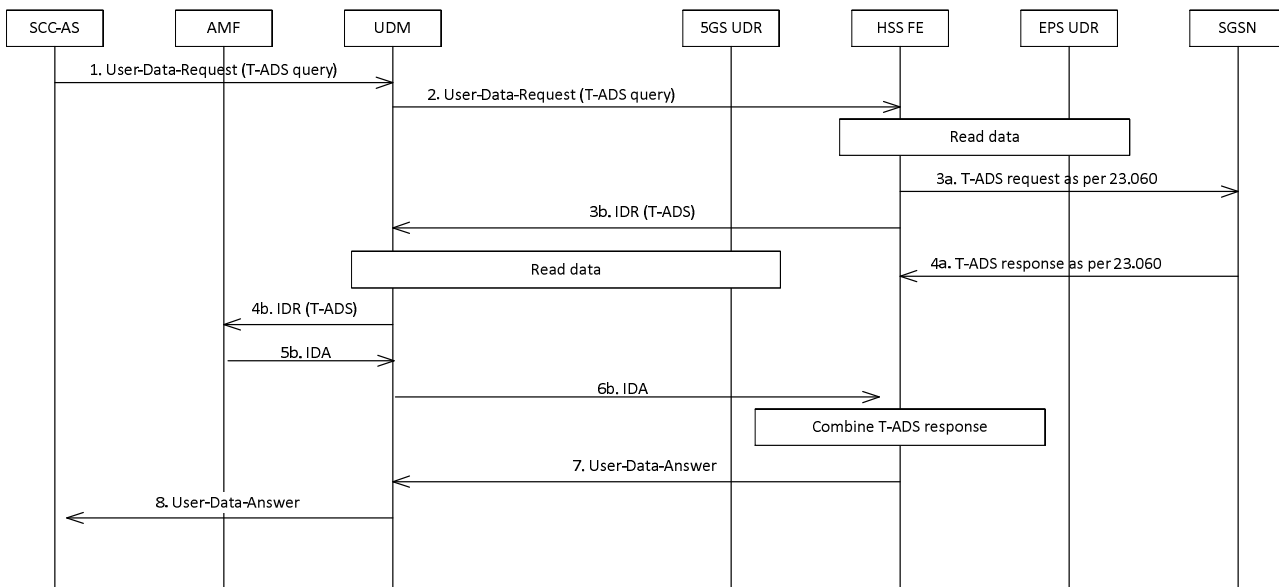

Figure 6.2.3.3-2: T-ADS Procedure with Single registration and UE is 5GS registered

In Figure 6.2.3.3-2 it is clear that due to the fake registration concept, the HSS is the entity that is in charge of taking T-ADS decisions, and not the UDM, even when the UE is registered in the 5GS with the UDM.

6.2.3.4 Supporting IMS related procedures

The procedure of the interaction between UDM and HSS FE is shown in Figure 6.2.3.4-1.

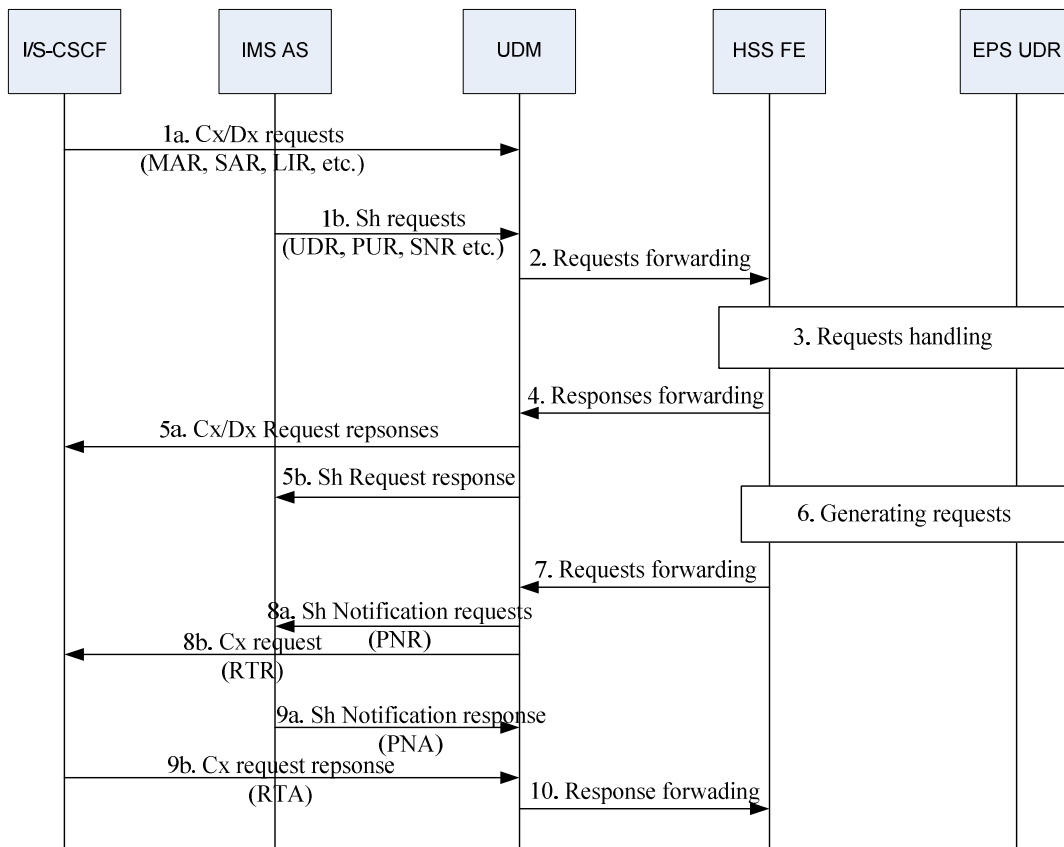

Figure 6.2.3.4-1: IMS procedures between UDM and HSS FE

- 1a or 1b. UDM receives Cx/Dx requests or Sh requests from IMS.
2. UDM identifies these requests are for IMS procedures, and forwards the requests to HSS FE.
3. HSS FE interacts with EPS UDR to handle the requests.
4. HSS FE sends responses to the requests to UDM.
- 5a or 5b. UDM forwards the received responses to IMS accordingly.
6. EPS UDR and HSS FE may generates requests to IMS, e.g. PNR to IMS AS or RTR to S-CSCF.
7. HSS FE sends the requests to UDM.
- 8a or 8b. UDM forwards the requests to IMS accordingly.
- 9a or 9b. IMS sends responses to the requests to UDM.
10. UDM forwards the responses to HSS FE.

NOTE: The other signalling interactions not related to the solution are not present in this figure for simplification.

6.2.3.5 SMSF address storage and retrieval

The procedure of the interaction between UDM and HSS FE is shown in Figure 6.2.3.5-1.

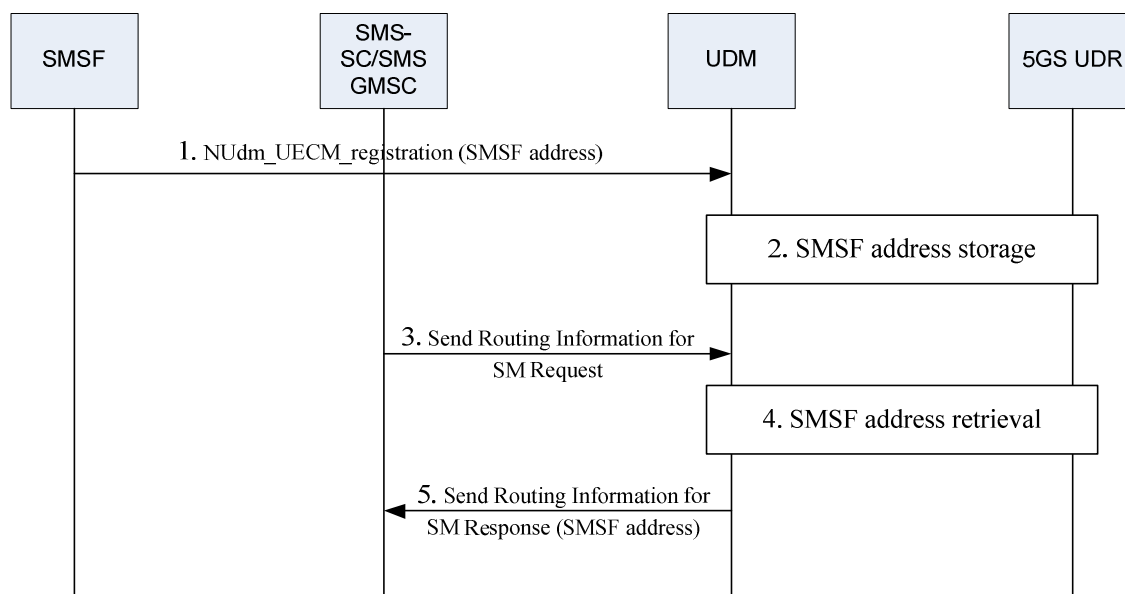

Figure 6.2.3.5-1: SMSF address storage and retrieval between UDM and HSS FE

1. SMSF invokes Nudm_UECM_Registration service operation to register its address in UDM.
2. UDM interacts with 5GS UDR to store the SMSF address.
3. When SMS-SC or SMS GMSC initiates MT SMS delivery procedure, SMS-SC or SMS GMSC send MAP request i.e. Send Routing Information for SM request, to UDM.
4. UDM interacts with 5GS UDR to retrieve stored SMSF address.
5. UDM responds with SMSF address.

6.2.3.6 MT SMS domain selection

The procedure of the interaction between UDM and HSS FE for MT SMS domain selection is shown in Figure 6.2.3.6-1.

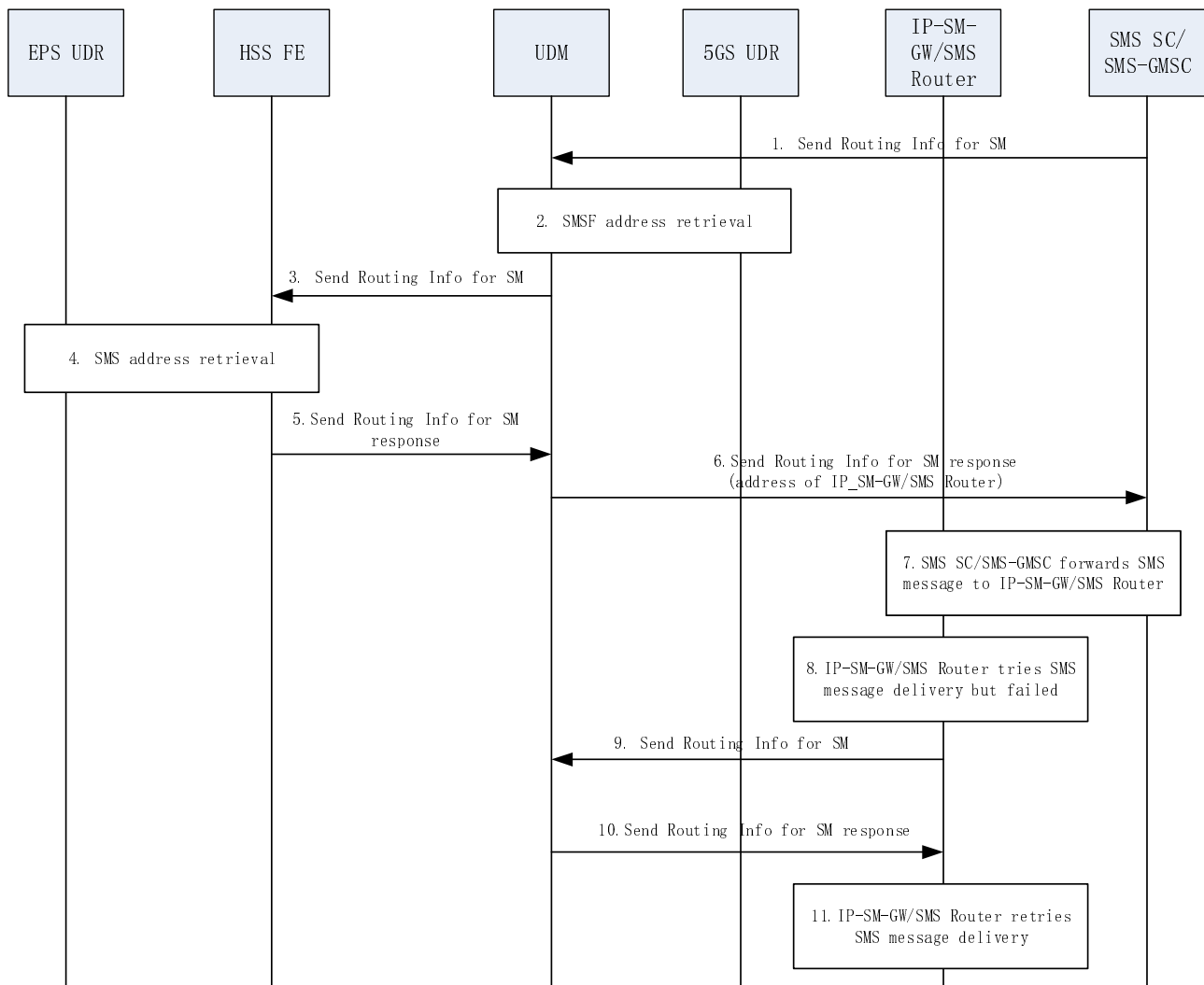

Figure 6.2.3.6-1: MT SMS domain selection

1. SMS SC/SMS-GMSC sends MAP Send Routing Info for SM request to UDM to query routing address for MT SMS.
2. UDM retrieves SMSF address from 5GS UDR as specified in clause 6.2.3.5.
3. UDM forwards MAP Send Routing Info for SM request to HSS FE to query more routing addresses for MT SMS.
4. HSS FE retrieves SMS routing addresses stored in EPS UDR.
5. HSS FE sends Send Routing Info for SM response with all addresses currently available, e.g. IP-SM-GW/ SMS Router address, MME address and MSC address.
6. Based on configured policy, UDM selects the SMS routing address to be used for SMS SC/SMS-GMSC, e.g. IP-SM-GW/SMS Router address, and returns the address to SMS SC/SMS-GMSC.
7. SMS SC/SMS-GMSC forwards SMS message to IP-SM-GW/SMS Router.
8. IP-SM-GW/SMS Router fails to deliver the SMS message to the UE via IMS.
9. IP-SM-GW/SMS Router may query UDM again to get other address for SMS delivery retry.
10. Based on configured policy, UDM returns other available SMS routing address to IP-SM-GW/SMS Router.
11. IP-SM-GW/SMS Router retries message delivery to the received address.

6.2.3.7 Messages-Waiting-Data handling

In this solution, the Messages-Waiting-Data as specified in TS 23.040 [21] are stored in HSS.

When SMS related entities, e.g. SMS SC/SMS-GMSC or IP-SM-GW, send corresponding requests to create or modify the Messages-Waiting-Data as specified in TS 23.040 [21] and TS 23.204 [22], the UDM forwards the requests with no change to HSS FE. The HSS FE interacts with EPS UDR to complete the handling of the Messages-Waiting-Data. The HSS FE sends responses to the UDM, which forwards the responses to the corresponding entities.

When the HSS detects or is informed that the MS/UE is reachable or is available again, the HSS clears corresponding flags and alerts SMS SC/SMS-GMSC as specified in TS 23.040 [21]. The UDM forwards the messages in these procedures.

When the UDM receives UE reachability notification, addition to the procedures defined in TS 23.502 [2], the UDM acts as a MME and generates request to HSS HE to notify the reachability of the UE as specified in TS 29.272 [23].

6.2.4 Impacts on existing services and interfaces

6.2.4.1 Authentication impacts

UDM supports:

- generating Diameter S6a Authentication-Information-Request message based on Nudm_UEAuthentication_Get service operation;
- forwarding Diameter S6a Authentication-Information-Request message to HSS-FE and Authentication-Information-Answer message with authentication vectors to MME;
- converting UTRAN authentication vector into 5GS authentication vector;
- generating the respond to Nudm_UEAuthentication_Get service operation invocation with 5GS authentication vectors, and sends the respond to AMF;
- generating and sending Location Update Request message to perform fake 4G registration in HSS FE when the UE is registered in 5G;
- de-registering the UE in 5G when it receives Cancel Location request with dedicated MME Identity from the HSS FE.

HSS FE: No impact.

5GS UDR: No impact.

EPS UDR: No impact.

6.2.4.2 IP address continuity impacts

UDM supports:

- forwarding Diameter S6a Update Location Request message to HSS FE;
- retrieving PGW-C+SMF FQDN from 5GS UDR after receiving Update Location Ack from HSS FE;
- generating new Update Location Ack to add PGW-C+SMF FQDN into the message and forwarding the message to MME.

HSS FE: No impact.

5GS UDR: No impact.

EPS UDR: No impact.

6.2.4.3 T-ADS for voice impacts

UDM supports:

- forwarding User-Data-Answer message to HSS FE;
- determine T-ADS result based on T-ADS information received from HSS FE and AMF.

HSS FE: No impact.

5GS UDR: No impact.

EPS UDR: No impact.

6.2.4.4 Supporting IMS related procedures

UDM supports:

- forwarding requests for IMS procedures received from IMS to HSS FE and further forwarding responses from HSS FE to IMS;
- forwarding requests for IMS procedures received from HSS FE to IMS and further forwarding responses from IMS to HSS FE.

HSS FE: No impact.

5GS UDR: No impact.

EPS UDR: No impact.

6.2.5 Evaluation

This solution has no impact on entities other than UDM.

The Solution does not provide the possibility to deploy a pure UDM without HSS functionality.

The EPS and 5GS UDRs both need to keep up to date registration status for the UE, i.e. the EPS UDR has to know the registration status of the UE also when the UE is in the 5GS (due to the fake registration concept). This means that there is duplication of registration data in EPS and 5GS UDR, which is adding load and storage requirement to the system

Due to the fake registration concept, the T-ADS master node is always the legacy HSS, not the UDM, even when the UE is 5GS registered. So, the functional allocation between 5GS and EPS specific entities is blurred for as long as there are combined 4G/5G subscribers.

Implementation to convert UTRAN authentication vectors to 5GS authentication vectors is needed.

NOTE: The above implementation should be evaluated by SA WG3.

6.3 Solution #3: Deployment and coexistence without interworking between UDM and existing HSS

6.3.1 Introduction

This solution applies to deployment scenario 1 and 2.

This solution proposes a deployment and coexistence alternative which avoids the need of specification of interworking procedures between UDM and the existing HSS.

6.3.2 High-level Description

This solution proposes an alternative for coexistence between UDM and HSS based on:

- Deploying HSS and UDM in a single network entity, referred as Combined HSS/UDM, supporting interfaces and procedures specified for 5GC, EPC and IMS.
- UDM and HSS deployed in the Combined network entity may interact with a 5GS UDR that stores 4G/IMS/5G subscription data for 5G enabled users (when using a common repository). The 5GS UDR may also store 2G/3G subscription profiles for 5G enabled users in case coexistence with 2G/3G networks is required. Alternatively, the Combined HSS/UDM may also use separate repositories for subscription data of 5G enabled users.
- The functions of the Combined HSS/UDM are provided by a single network entity, so that the interactions between HSS and UDM within the Combined entity are performed internally and therefore it is not required to define such interworking.
- The existing HSS and EPS UDR keep serving only 4G users. The existing EPS UDR may also store 2G/3G subscription profiles for non 5G enabled users in case coexistence with 2G/3G networks is required.
- A routing solution routes Diameter EPC/IMS requests to either the Combined HSS/UDM for 5G enabled users or the existing HSS for 4G only users. This kind of solution can be achieved e.g. by using a network entity that provides SLF/DRA functionality and/or by local configuration in network entities interacting with HSS (e.g. configuring IMSI ranges in MME), and other alternatives may be possible. The routing solution includes redundancy mechanisms to prevent single point of failure issues.
- Considering that HLR is an integral part of the HSS, both within the existing HSS and the HSS within the Combined HSS/UDM, the routing solution is also required to route MAP requests to either the Combined HSS/UDM for 5G enabled users or the existing HSS for non 5G enabled users. This enables the coexistence of 2G/3G domain in both HSS platforms including the support for MAP based SMS use cases.
- There is no need of interworking between UDM and existing HSS out of the Combined network entity.
- The different options regarding deployment of subscription data repository are described below, gathering the considerations described previously.
- **Option 1:** A common repository is used for the Combined HSS/UDM. Subscription data of new 5G enabled users is directly provisioned in 5GS UDR. Subscription data of existing 4G users that becomes 5G enabled is relocated from existing EPS UDR to 5GS UDR. When and how the subscription data relocation is performed depends on the overall migration plan and the procedure designed for that purpose, and it is out of scope of the description of this solution.

This option may be considered the most appropriate for a multivendor deployment, while providing centralization of subscription data, allowing consolidation of user profiles for a given user in a single repository. This consolidation simplifies provisioning process, providing a single point of provisioning and ensuring data consistency.

It minimizes deployment impacts, providing a flexible network evolution to 5G while users become 5G enabled through subscription relocation according to plans and speed chosen by the operator.

Additionally, this option may be considered to follow a smooth evolution of the subscription data repository used for 5G enabled users to a cloud native deployment.

Figures 6.3.1-1 and 6.3.1-2 show the network architecture using a common repository for the Combined HSS/UDM:

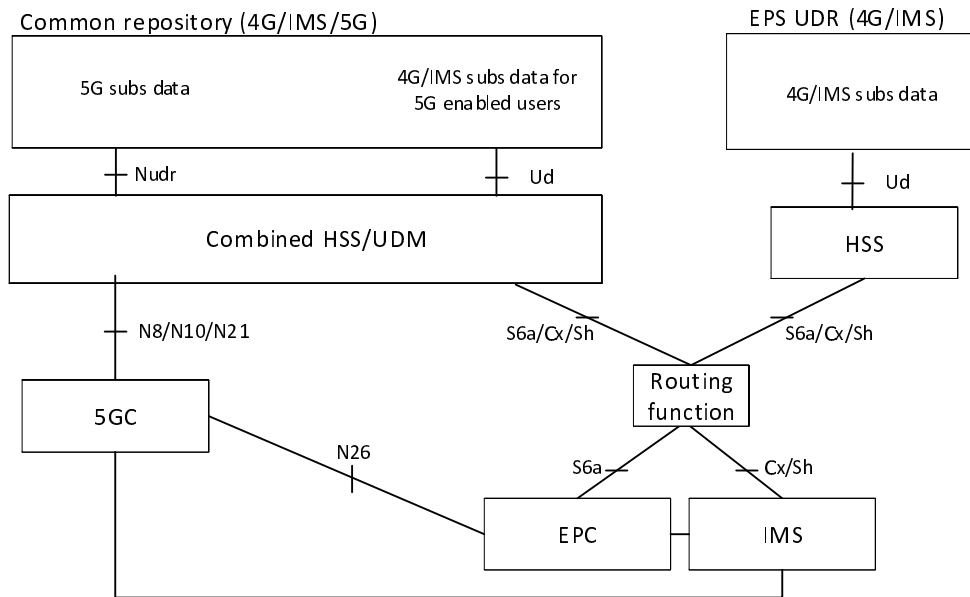

Figure 6.3.1-1: Coexistence of existing HSS and Combined HSS/UDM with common repository used by the Combined entity

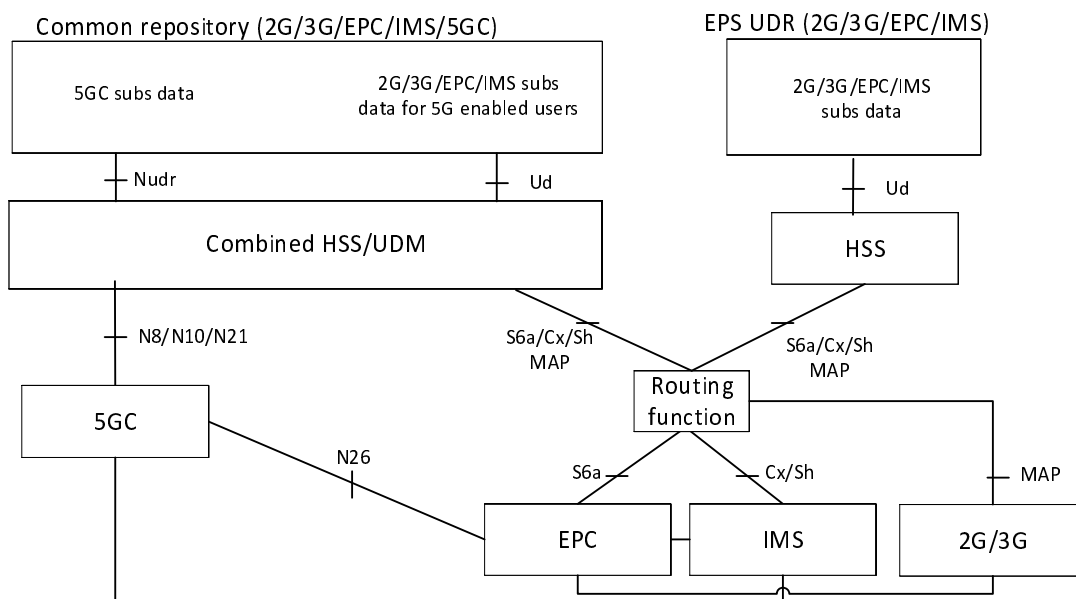

Figure 6.1.1-2: Coexistence of existing HSS and Combined HSS/UDM with common repository used by the Combined entity – Including MAP access

- **Option 2:** Separate repositories are deployed for subscription data of 5G enabled users accessed by the Combined HSS/UDM. In this case, provisioning and/or subscription relocation to EPS UDR used by the Combined HSS/UDM is also needed.

This option allows multivendor deployment for 5G enabled users and legacy users, as well as keeping open the way for the evolution of the subscription data repository used for 5G enabled users to a cloud native deployment. However, subscription data centralization is not achieved, and deployment, management and provisioning of subscription repositories becomes not optimal and complex.

Figures 6.3.1-3, and 6.3.1-4 show the network architecture using separate repositories for the Combined HSS/UDM:

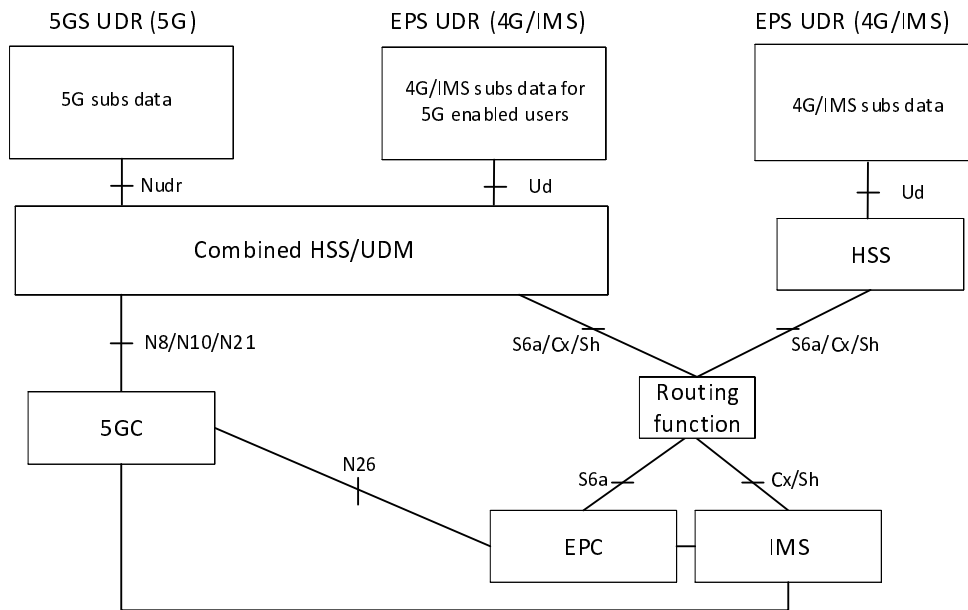

Figure 6.3.1-3: Coexistence of existing HSS and Combined HSS/UDM with separate repositories deployed for the Combined entity

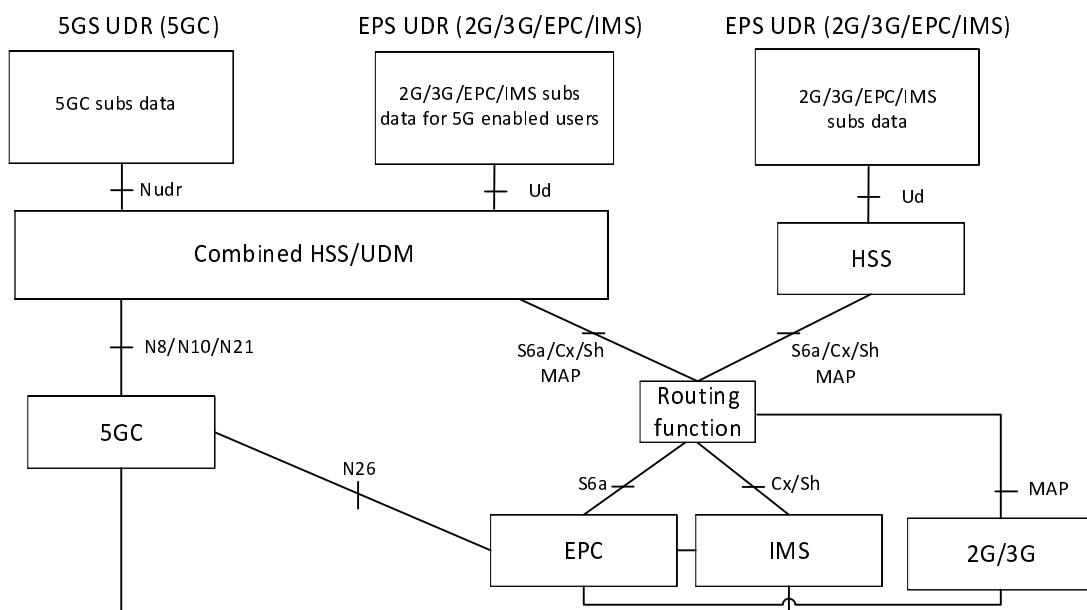

Figure 6.3.1-4: Coexistence of existing HSS and Combined HSS/UDM with separate repositories deployed for the Combined entity - Including MAP access

- **Option 3:** Separate repositories are used and the existing EPS UDR keeps storing 4G/IMS subscription data for 5G enabled users as well as 4G only users, as shown in figures 6.3.1-5, and figure 6.3.1-6. Subscription relocation is not required in this option.

Both the existing HSS and the HSS within the Combined entity interact with the EPS UDR using the same proprietary Ud interface, implying that a multivendor deployment will require integration of the non-standard Ud interface with the HSS in the Combined HSS/UDM.

This option does not allow centralization of user profiles for a given user in a single repository, making provisioning more complex as multiple subscription repositories are required to be populated for the same user.

It enables evolution of subscription repository to cloud native technology only for the 5G profiles. EPC and IMS profiles are assumed to be kept in the existing EPS UDR using legacy repository technology.

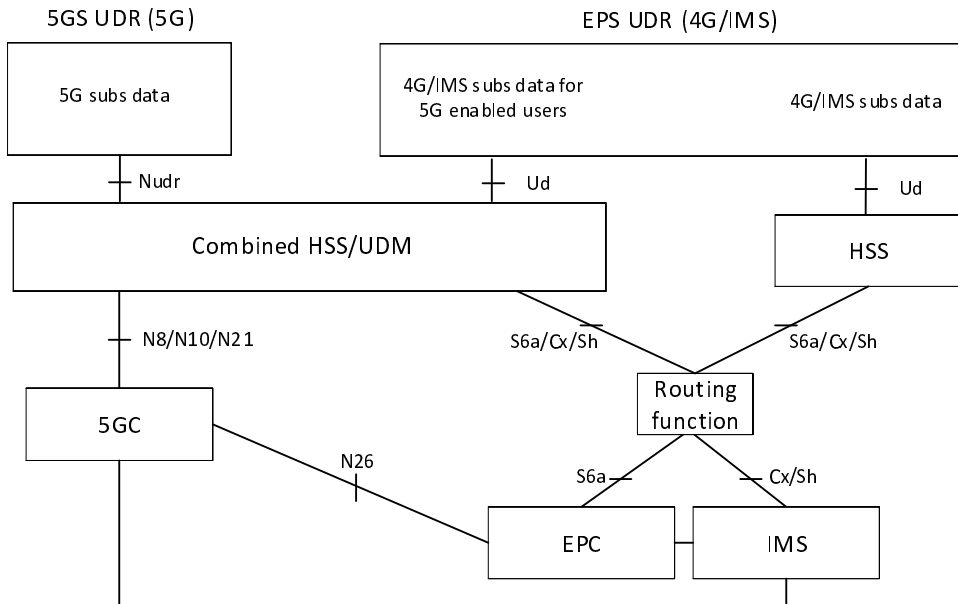

Figure 6.3.1-5: Coexistence of existing HSS and Combined HSS/UDM with separate repositories using existing EPS UDR for 4G/IMS subscription data

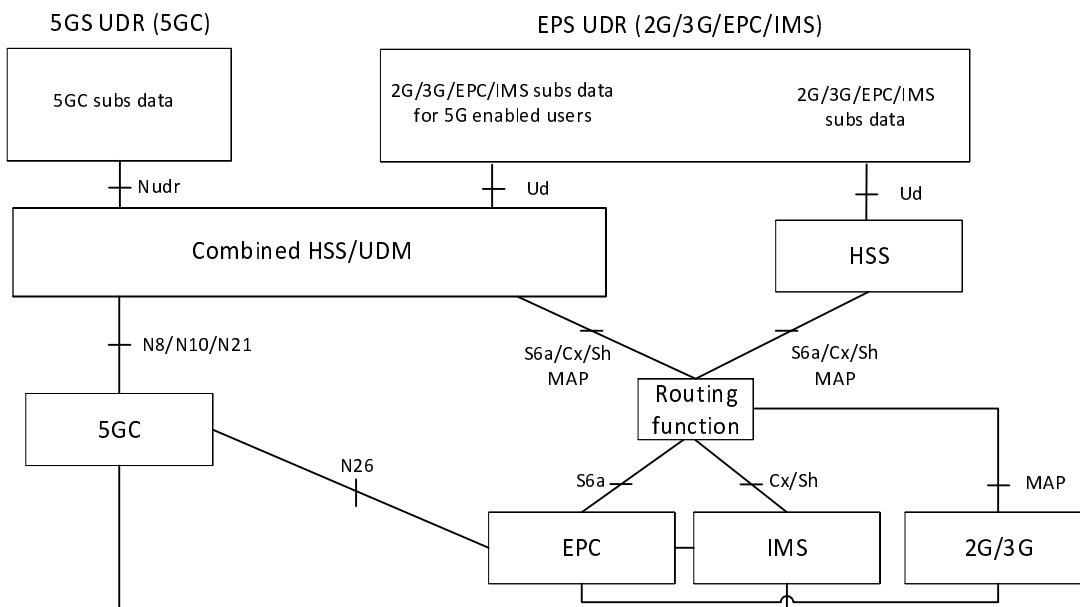

Figure 6.3.1-6: Coexistence of existing HSS and Combined HSS/UDM with separate repositories using existing EPS UDR for 4G/IMS subscription data - Including MAP access

- **Option 4:** Another option is to deploy a single repository to store subscription data for all domains used by the Combined HSS/UDM and the existing HSS, as depicted in figures 6.3.1-7, and 6.3.1-8. This option may not require subscription relocation either.

This alternative allows user profiles centralization, although in a multivendor deployment it will require integration of the non-standard Ud interface with the HSS in the Combined HSS/UDM.

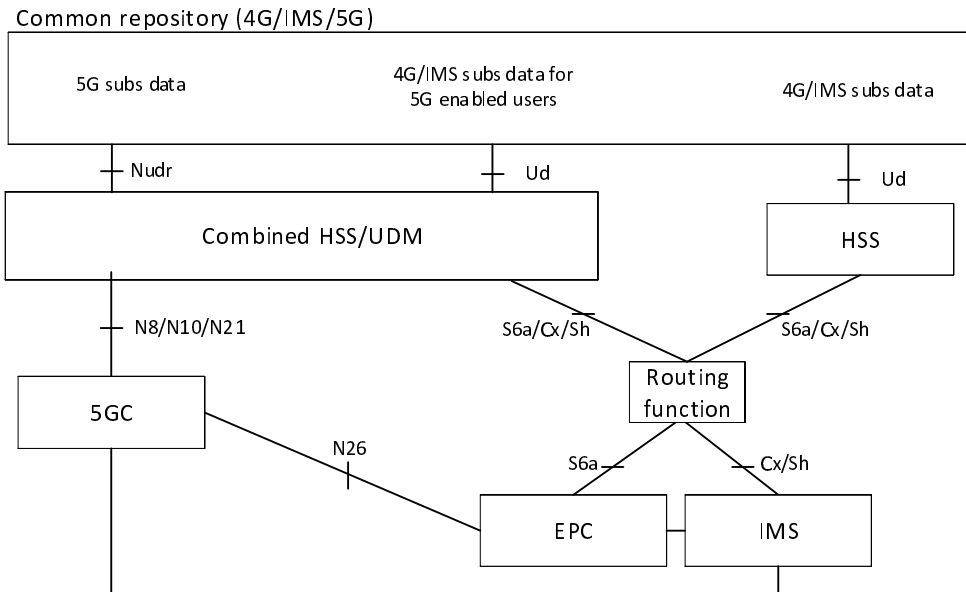

Figure 6.3.1-7: Coexistence of existing HSS and Combined HSS/UDM using a common repository

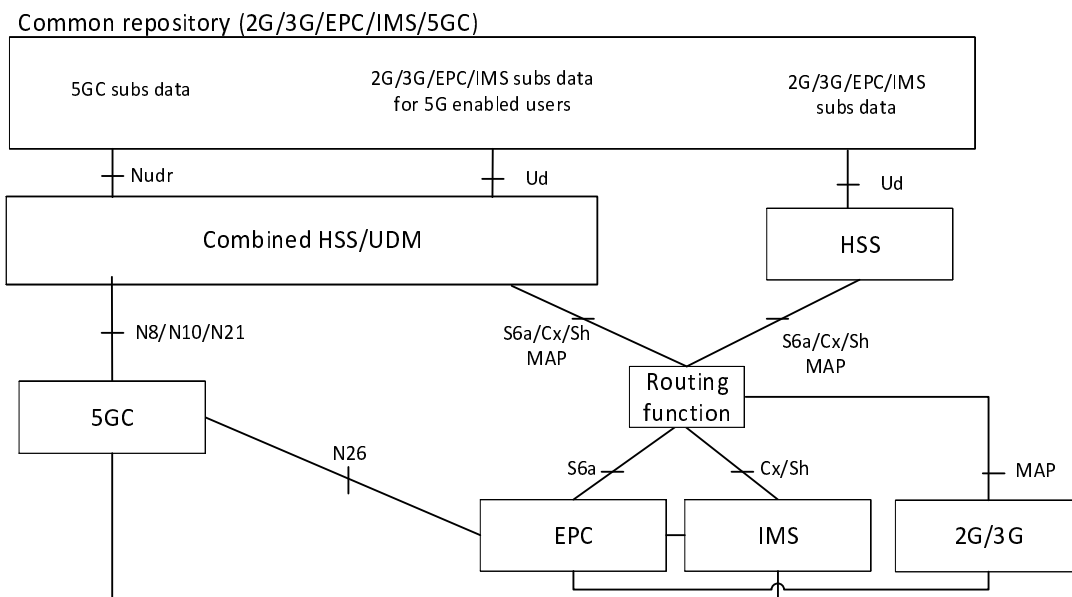

Figure 6.3.1-8: Coexistence of existing HSS and Combined HSS/UDM using a common repository - Including MAP access

6.3.3 Services and Illustrated Procedures

The interactions between UDM and HSS within the Combined network entity are internal, so it is not required to define such interworking.

6.3.4 Impacts on existing services and interfaces

This solution has no impact on existing services and interfaces.

6.3.5 Evaluation

Solution 3 proposes a coexistence scenario where a Combined HSS/UDM network entity serving 5G enabled users can coexist without interaction with any existing HSS supporting EPC and IMS for 4G only users. Since there is no interaction needed between UDM and the existing HSS out of the Combined entity, this solution does not require any standardization effort. Additionally, this solution avoids any impact on existing nodes (HSS, EPS UDR), services, protocols and interfaces. Some options require migration of subscriber data.

For IMS and EPC services, the solution requires the use of a routing solution which can be based on standard functions (e.g. DRA/SLF) and it is normally deployed in the operator's network for different purposes.

In case of coexistence with 2G/3G networks (including support for MAP based SMS use cases) is required, the routing solution is also required to route MAP requests to either the Combined HSS/UDM for 5G enabled users or the existing HSS for non 5G enabled users.

Impacts are limited to provisioning/configuration updates for the routing function to route Diameter EPC/IMS requests and/or MAP requests to either the Combined HSS/UDM for 5G enabled users or the existing HSS for non 5G enabled users.

This solution offers different UDR deployment alternatives, from which option 1 as described previously is considered the option providing the most future proof benefits in terms of centralization/consolidation of subscription data for 5G enabled users, management of subscription data, multivendor support and network evolution.

However, an operator may find among the different alternatives proposed the option that fits better its network evolution plans, based on the current deployment and evaluation of the aspects the operator considers as most relevant.

7 Conclusions

It is concluded that normative work, as specified in the present document and TS 29.563 [20], proceeds based on solution defined in clause 6.1 as normative optional feature, both stage 2 and stage 3 for deployments in which upgrading legacy systems to service based architectures is a feasible/acceptable option for the network operator.

Solutions defined in clauses 6.2 and 6.3 are concluded as implementation/deployment options with no need of normative work for scenarios where migration of subscription data or upgrades of legacy systems are not possible/feasible.

Annex A: Change history

Change history							
Date	Meeting	TDoc	CR	Rev	Cat	Subject/Comment	New version
2019-05	SP#84	SP-190466				Generated from v0.2.0 for plenary approval	1.0.0
2019-08	SP#84	-	-	-	-	MCC Editorial update for publication after TSG SA approval	16.0.0
2019-09	SP#85	SP-190623	0001	-	F	TR 23.973 clean up	16.1.0

History

Document history		
V16.1.0	November 2020	Publication