

ETSI TR 123 911 V3.0.1 (2001-10)

Technical Report

**Digital cellular telecommunications system (Phase 2+) (GSM);
Universal Mobile Telecommunications System (UMTS);
Technical Report on Out-of-band transcoder control
(3GPP TR 23.911 version 3.0.1 Release 1999)**



Reference

RTS/TSGN-0223911UR1

Keywords

GSM, UMTS

ETSI

650 Route des Lucioles
F-06921 Sophia Antipolis Cedex - FRANCE

Tel.: +33 4 92 94 42 00 Fax: +33 4 93 65 47 16

Siret N° 348 623 562 00017 - NAF 742 C
Association à but non lucratif enregistrée à la
Sous-Préfecture de Grasse (06) N° 7803/88

Important notice

Individual copies of the present document can be downloaded from:

<http://www.etsi.org>

The present document may be made available in more than one electronic version or in print. In any case of existing or perceived difference in contents between such versions, the reference version is the Portable Document Format (PDF). In case of dispute, the reference shall be the printing on ETSI printers of the PDF version kept on a specific network drive within ETSI Secretariat.

Users of the present document should be aware that the document may be subject to revision or change of status.

Information on the current status of this and other ETSI documents is available at

<http://portal.etsi.org/tb/status/status.htm>

If you find errors in the present document, send your comment to:

editor@etsi.fr

Copyright Notification

No part may be reproduced except as authorized by written permission.
The copyright and the foregoing restriction extend to reproduction in all media.

© European Telecommunications Standards Institute 2001.

All rights reserved.

Intellectual Property Rights

IPRs essential or potentially essential to the present document may have been declared to ETSI. The information pertaining to these essential IPRs, if any, is publicly available for **ETSI members and non-members**, and can be found in ETSI SR 000 314: "*Intellectual Property Rights (IPRs); Essential, or potentially Essential, IPRs notified to ETSI in respect of ETSI standards*", which is available from the ETSI Secretariat. Latest updates are available on the ETSI Web server (<http://www.etsi.org/legal/home.htm>).

Pursuant to the ETSI IPR Policy, no investigation, including IPR searches, has been carried out by ETSI. No guarantee can be given as to the existence of other IPRs not referenced in ETSI SR 000 314 (or the updates on the ETSI Web server) which are, or may be, or may become, essential to the present document.

Foreword

This Technical Report (TR) has been produced by the ETSI 3rd Generation Partnership Project (3GPP).

The present document may refer to technical specifications or reports using their 3GPP identities, UMTS identities or GSM identities. These should be interpreted as being references to the corresponding ETSI deliverables.

The cross reference between GSM, UMTS, 3GPP and ETSI identities can be found under www.etsi.org/key.

Contents

Intellectual Property Rights	2
Foreword.....	2
Foreword.....	4
1 Scope	5
2 References	5
3 Definitions and Abbreviations.....	5
4 Introduction	5
5 Service requirements	6
6 Interaction with existing services	6
7 Proposed procedures.....	7
7.1 In-band TFO (enhancement)	7
7.2 Out-of-band transcoder control (Alternative 1).....	8
7.3 Out-of-band transcoder control (Alternative 2).....	11
7.4 Out-of-band transcoder control (Alternative 3).....	14
7.5 Out-of-band transcoder control (Alternative 4).....	17
7.5.1 UMTS UE – UMTS UE call, APM possible in the whole path of the call.....	17
7.5.2 UMTS MS – UMTS MS call, APM not possible in the whole path of the call.....	19
7.5.3 UMTS UE – GSM UE call.....	20
7.5.4 GSM MS to UMTS UE call, APM supported in GSM	22
7.5.5 Handover from UMTS to GSM, after end-to-end transcoder free operation establishment.....	24
8 Comparison of proposed procedures	25
8.1 Service limitations.....	25
8.1.1 Network to be applied	25
8.2 Impacts on the current system.....	25
8.2.1 Impacts to the current GSM system	25
8.2.2 Impacts to the specifications	25
8.2.3 Punctuality for Release 99.....	26
8.3 Configuration	26
8.3.1 Hardware configurations	26
8.4 Quality of service	27
8.4.1 Transmission quality	27
8.5 Maintenance for future expansion.....	27
8.5.1 Transcoder type addition	27
8.5.2 Transcoder reallocation	27
9 Conclusion.....	27
Annex A (informative): Change history	29
History	30

Foreword

This Technical Report (TR) has been produced by the 3rd Generation Partnership Project (3GPP).

The contents of the present document are subject to continuing work within the TSG and may change following formal TSG approval. Should the TSG modify the contents of the present document, it will be re-released by the TSG with an identifying change of release date and an increase in version number as follows:

Version x.y.z

where:

- x the first digit:
 - 1 presented to TSG for information;
 - 2 presented to TSG for approval;
 - 3 or greater indicates TSG approved document under change control.
- y the second digit is incremented for all changes of substance, i.e. technical enhancements, corrections, updates, etc.
- z the third digit is incremented when editorial only changes have been incorporated in the document.

1 Scope

The purpose of the present document is to study:

1. The feasibility of out-of-band transcoder control in UMTS/IMT-2000 networks.
2. The impact of out-of-band transcoder control on the UMTS/IMT-2000 specifications.

The present document introduces one enhanced in-band transcoder control procedure and four out-of-band transcoder control procedures that might be adaptable for transcoder control in UMTS/IMT-2000 networks. Then compare each procedure from various point of views to seek the most feasible procedure.

2 References

The following documents contain provisions which, through reference in this text, constitute provisions of the present document.

- References are either specific (identified by date of publication, edition number, version number, etc.) or non-specific.
- For a specific reference, subsequent revisions do not apply.
- For a non-specific reference, the latest version applies.

[1] GSM 02.53: "Digital cellular telecommunications system (Phase 2+); Tandem Free Operation (TFO); Service description; Stage 1".

[2] GSM 03.53: "Digital cellular telecommunications system (Phase 2+); Tandem Free Operation (TFO); Service description; Stage 2".

3 Definitions and Abbreviations

Transcoder	The equipment to convert the user information. An example of the transcoder is voice codec equipment.
Transcoder Control	The procedure for avoiding or reverting transcoders that located in the network in case of the mobile to mobile call.

4 Introduction

In order to improve voice quality for mobile to mobile call (MT-MT call) in GSM Phase 2+ network, Tandem Free Operation (TFO) using in-band signalling has been specified. The equivalent function in Japan's PDC (Personal Digital Cellular) network is known as Transcoder Bypass, which has been specified to make use of out-of-band signalling control (i.e. by the PDC-MAP protocol).

Besides, there might be other advantage avoiding the transcoders. Since the voice coding rate used by mobile is relatively lower than 64kbps coding rate that is used in the fixed network, The transcoder avoiding connection could be used to reduce inter-Mobile services Switching Centre (MSC) transmission bandwidth.

These advantages should be applied not only for speech calls but also for data communications such as Facsimile, Modem, PPP/PIAFS and so on.

The UMTS Phase 1 network operator should have the option to implement the Transcoder Control by making use of either TFO, out-of-band transcoder control or both.

5 Service requirements

The low bit rate coding (e.g. 8kbps or 16kbps) has been adapted to the voice coding in the mobile networks to make use of radio resources efficiently. The speech quality in the mobile networks is distinctly degraded than the fixed networks using 64kbps PCM format. The degradation of speech quality is more obvious in the case of MT-MT call since there are two transcoders intervened to reform once to the 64kbps PCM format in the network. In this particular case (MT-MT call and each MT uses the same transcoder type), the intervened two transcoders in the network can be avoided and improves the speech quality as the result.

The requirements for transcoder control are as follows:

The capability to negotiate preferable transcoder type to be used between two end nodes and avoid two transcoders in the network.

The originating MT may indicate preferable transcoder type list for transcoder negotiation and the list should be conveyed to the terminating MT through the networks to decide the transcoder type to be used and establish the transcoder avoiding connection.

The terminating MT enables to select transcoder type by menu based on either the preferable transcoder type specified by the originating MT or the capability of the originating MT identified in subscription profile.

– The capability to control (avoiding and reverting) transcoders in the network.

– Avoiding transcoders:

The intervened transcoders in the network should be avoided at anytime depending on the result of transcoder negotiation procedure and the situation of the Call State. Mostly, the followings are typical cases for avoiding transcoders:

– Call establishment phase.

– The transcoder avoiding connection was reverted to the normal call connection by some reasons, then returns back to the Call State that can configure the transcoder avoiding connection again. (Ex. Multiparty call returns to the simple A to B call connection).

– Reverting to the normal call connection from the transcoder avoiding connection:

If the call connection encounters the following situations, the transcoder avoiding connection is reverted to the normal call connection.

- SS interruption.
- DTMF signal.
- The transcoder type to be handled is not only speech codec but also multimedia codec. The transcoder control should have enough expandability to support future enhancements of transcoder type.
- The transcoder control procedure should be independent from the location of the transcoder in the network. (Currently, TSG-S2 has a work item to seek the reasonable transcoder location for UMTS/IMT-2000).
- The transcoder control procedure should not cause the perceivable time lag in case of both establishing transcoder avoiding connection and reverting to normal call connection.
- The transcoder avoiding connection should be maintained if the MT executes hand-over.
- The interworking ability with the existing 2G system (I.e. GSM system) should be clearly defined.

6 Interaction with existing services

This section defines the possible interactions with existing services when a call configures or going to configure the transcoder avoiding connection. When a call encounters the following situations, the transcoder avoiding connection may not be applicable and reverted to the normal call connection.

- Multiparty call.

Where more than two parties are involved in a call, transcoder avoiding connection should be reverted to the normal call connection. If a call connection returns to the simple A to B call, transcoder avoiding connection should be applied again.

- Applying service announcements and tones.

The transcoder avoiding connection should be reverted to the normal call connection when user applied any speech announcements or tones by the network. The followings are typical cases.

- Announcements applied by IN services (ex. Prompting).
- Announcements applied by call forwarding services.
- Notice tones applied to user due to interrupting of call waiting or call hold service.
- DTMF signal is communicated during a call.

7 Proposed procedures

7.1 In-band TFO (enhancement)

The table 7.1-1 illustrates the format of the TFO_REQ Message that is used to identify codec that has been used at sender side. Bit 12 –15 are assigned for codec identification. There are 12 bits out of 16 remained for future codec type expansion.

The table 7.1-2 illustrates the format of Codec_List Expansion Block that is used to identify all codecs that supported at sender side. Bit 2-10 and 12-15 are assigned to identify whether specific codec is supported or not at sender side. There are 10 bits out of 13 remained for future codec type expansion.

According to above analysis, Adding up to 10 types of transcoders is easily expandable for In-band TFO.

In case of adding more than 10 types of transcoders, the message extension can be used. As you can see every message, Bit 19-20 are assigned for indication of message extension.

Table 7.1-1: TFO_Req_Extension_Block

Bit	Description	Comment
Bit 1	"0"	normal IS-Message Sync Bit, constant.
Bit 2	Req_Ident	Identifies the TFO_Req_Extension_Block
	Req_Ident == "0"	REQ or REQ_L: Codec Field identifies the "used" Codec
	Req_Ident == "1"	REQ_P: Codec Field identifies the "preferred" Codec
Bit 3..10	Signature	An 8-bit random number to facilitate the detection of circuit loop back conditions and to identify the messages source
Bit 11	"0"	normal IS-Message Sync Bit, constant
Bit 12.. 15:	Codec	Identifies the GSM Codec, which is currently used (Req_Ident == "0") or which is preferred (Req_Ident == "1") by the sender
	Codec == "0.0.0.0"	GSM Full Rate Codec
	Codec == "0.0.0.1"	GSM Half Rate Codec
	Codec == "0.0.1.0"	GSM Enhanced Full Rate Codec
Bit 16..18:	CRC	CRC protecting Req_Ident, Signature and Codec, see 6.1.2
Bit 19..20:	EX	The normal 2 bits for IS_Message Extension.
	EX == "0.0"	REQ: No other extension block follows
	EX == "1.1"	REQ_L or REQ_P: The Codec_List-Extension Block follows

Table 7.1-2: Codec_List Extension Block

Bit	Description	Comment
Bit 1	"0"	normal IS-Message Sync Bit, constant.
Bit 2..10	Codec_List_1	First part of Codec_List. For each GSM Codec one bit is reserved. If the bit is set to "0" then the specific Codec is not supported; if the bit is set to "1" then the specific Codec could be used. Bit 2: GSM_FR Codec Bit 3: GSM_HR Codec Bit 4: GSM_EFR Codec The remaining bits are reserved for future Codecs.
Bit 11	"0"	normal IS-Message Sync Bit, constant
Bit 12.. 15:	Codec_List_2	Second part of the Codec_List All four bits are reserved for future Codecs
Bit 16..18:	CRC	A 3-bit CRC protecting the Codec_List fields, see 6.2.2
Bit 19..20:	EX	The normal 2 IS_Message Extension bits.
	EX == "0.0"	No other extension block follows.

7.2 Out-of-band transcoder control (Alternative 1)

The origination MSC negotiates with the terminating MSC by ISUP/B-ISUP message in call set up phase. The Application Transport Mechanism (APM) message in ISUP/B-ISUP is used for negotiation. See Note 1 for details of APM message.

In this scenario, the transcoder type information needs to be newly defined as the parameter for APM message.

If this technique is deployed in the GSM network, the interworking with GSM system is possible and this results that the transcoders in the network can be avoided in case of the GSM–UMTS call connection. If this technique is not deployed in the GSM network, FFS is required.

Note 1: The APM message in ISUP is defined in ITU-T Recommendation Q.765 (05/98), Q.761-Q.763 addendum 1 in May 1999. The APM message in B-ISUP is defined in draft Q.2765 and supposed to be finalised in November 1999.

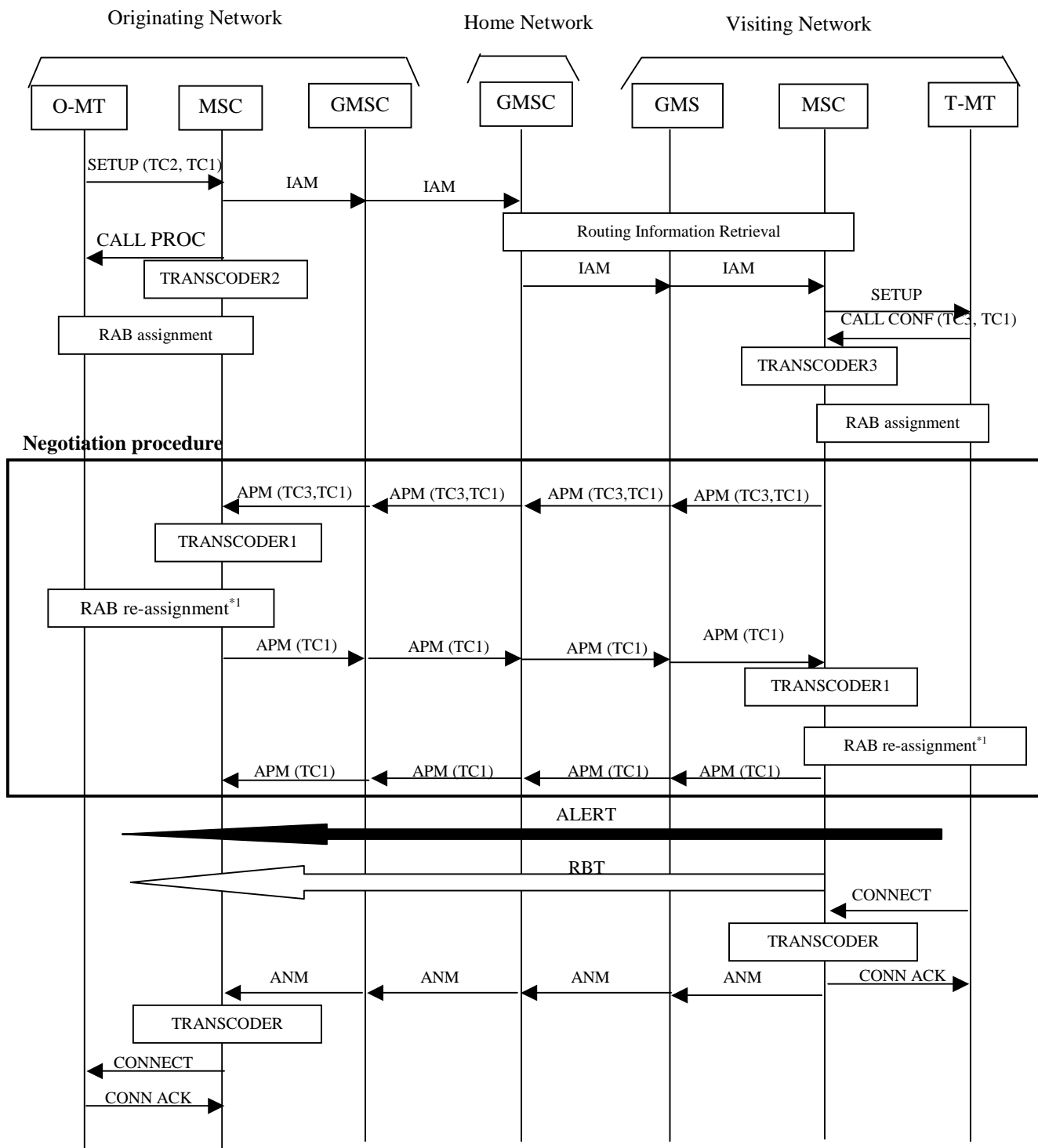

TC1, TC2 and TC3 are the types of the transcoder.

*1: If selected transcoder type isn't the first candidate of transcoder type.

Figure 7.2: Out-of-band transcoder control (Alternative 1)

1. Procedures in the originating network

- A. MT sends SETUP message that includes “transcoder type list” in “bearer capability” parameter to MSC. “Transcoder type list” indicates transcoder types supported by the originating mobile terminal with preferable order. (E.g. speech version 1, then speech version 2)
- B. When MSC receives SETUP message from MT, MSC memorises the “transcoder types” and MSC executes access link set-up procedure to establish access link between mobile terminal and MSC with default bearer capability based on the received SETUP message.
- C. MSC sends IAM message to terminating MSC with specifying the 64kbps UDI bearer for speech path establishment. If REL message is returned because of difficulty for providing UDI path in the transit network, MSC retries to send IAM message again with specifying speech bearer.
- D. When MSC receives “transcoder types” in APM message from terminating MSC, MSC selects a transcoder type referring to the prioritised transcoder list from both originating MT and terminating MT. If necessary, MSC notifies selected transcoder type to the originating MT and executes access link modification procedure with the bearer capability that supports selected transcoder type. MSC sends selected transcoder type with APM message to the terminal MSC to inform the selected transcoder type.
- E. MSC receives the selected transcoder type in APM message from terminating MSC. If selected transcoder in the terminating MSC is the same as the transcoder selected by the originating MSC, it means that the terminating MSC established the appropriate RAB and transcoder in the terminating MSC could be avoidable. If the other transcoder is selected, it means the terminating MSC failed to establish the appropriate RAB. In this case, originating MSC has to abandon to avoid the transcoder either.
- F. When MSC receives ANM message from terminating MSC, transcoder avoiding procedure is executed if possible.

2. Procedures in the terminating network

- A. When MSC receives IAM message from originating MSC, MSC sends SETUP message to MT.
- B. MSC receives CALL CONFIRM message which includes “transcoder type list” in “bearer capability” parameter from MT. The “Transcoder type list” indicates transcoder types supported by the terminating mobile terminal with preferable order. (E.g. speech version 1, then speech version 2)
- C. MSC sends APM message to originating MSC to indicate the terminating transcoder types and executes access link set-up procedure to establish access link between mobile terminal and MSC with default bearer capability.
- D. MSC receives the selected transcoder type in APM message from originating MSC. If necessary, MSC notifies selected transcoder type to the terminating MT and executes access link modification procedure with the bearer capability that supports selected transcoder type. If the MSC fails to modify access link establishment, MSC selects another transcoder and transcoder avoiding procedure is not executed.
- E. MSC sends APM message to the originating MSC to inform selected transcoder type in the terminating MSC.
- F. When MSC receives CONNECT message from MT, MSC sends ANM message to originating MSC and transcoder avoiding procedure is executed if possible.

7.3 Out-of-band transcoder control (Alternative 2)

There are two steps for negotiation in this scenario. Firstly, the terminating MSC informs its MSC address and call reference information to the originating MSC using APM message. The MSC address is conveyed using the generic number parameter. In order to use generic number parameter for MSC address, new number has to be assigned to the number qualifier indicator that manages the information of generic number.

Secondly, originating MSC starts negotiation with terminating MSC using newly defined MAP message. MAP_TRANSCODER_Notification message and MAP_TRANSCODER_Modification message need to be created for transcoder negotiation.

If this technique is deployed in the GSM network, the interworking with GSM system is possible and this results that the transcoders in the network can be avoided in case of the GSM-UMTS call connection. If this technique is not deployed in the GSM network, FFS is required.

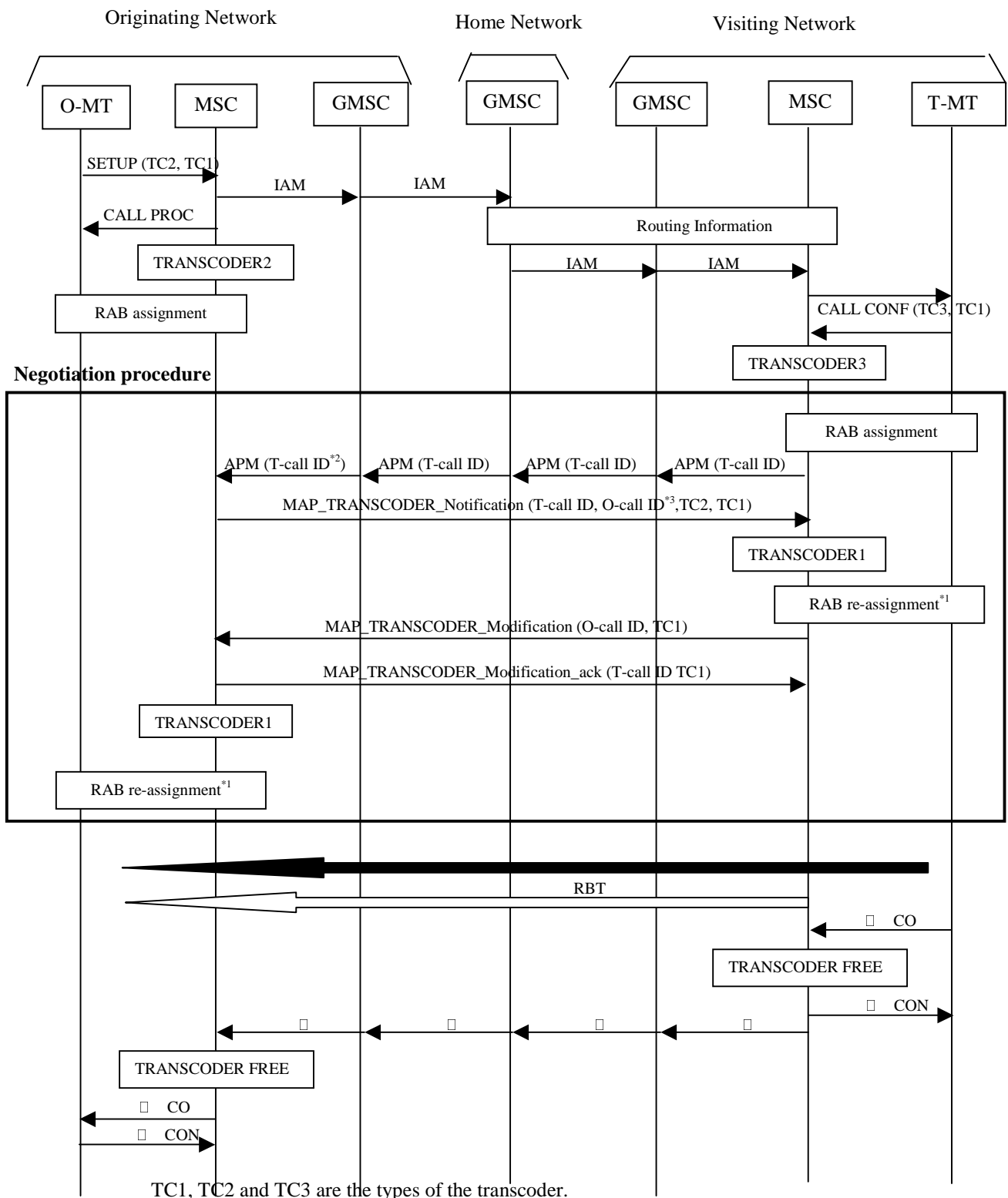

TC1, TC2 and TC3 are the types of the transcoder.

*1 If selected transcoder type isn't the first candidate of transcoder type.

*2 T-call ID: Terminating MSC address and call reference.

*3 O-call ID: Originating MSC address and call reference.

Figure 7.3: Out-of-band transcoder control (Alternative 2)

1. Procedures in the originating network

- a) MT sends SETUP message that includes “transcoder type list” in “bearer capability” parameter to MSC. “Transcoder type list” indicates transcoder types supported by the originating mobile terminal with preferable order. (E.g. speech version 1, then speech version 2)
- b) When MSC receives SETUP message from MT, MSC memorises the “transcoder types” and MSC executes access link set-up procedure to establish access link between mobile terminal and MSC with default bearer capability based on the received SETUP message.
- c) MSC sends IAM message to terminating MSC with specifying the 64kbps UDI bearer for speech path establishment. If REL message is returned because of difficulty for providing UDI path in the transit network, MSC retries to send IAM message again with specifying speech bearer.
- d) MSC receives terminating MSC address and call reference in APM message from terminating MSC, MSC sends transcoder types to terminating MSC by MAP_TRANSCODER_Type_Notification message.
- e) MSC receives the selected transcoder type in MAP_TRANSCODER_Type_Modify message from the terminating MSC. If necessary, MSC notifies selected transcoder type to the originating MT and executes access link modification procedure with the bearer capability that supports selected transcoder type. If the MSC fails to modify access link establishment, MSC selects another transcoder and abandons to avoid transcoder.
- f) MSC notifies the selected transcoder type to the terminating MSC using MAP_TRANSCODER_Type_Modify_ack message.
- g) When MSC receives ANM message from terminating MSC, transcoder avoiding procedure is executed if possible.

2. Procedures in the terminating network

- a) When MSC receives IAM message from originating MSC, MSC sends SETUP message to MT.
- b) MSC receives CALL CONFIRM message which includes “transcoder type list” in “bearer capability” parameter from MT. “Transcoder type list” indicates transcoder types supported by the terminating mobile terminal with preferable order. (E.g. speech version 1, then speech version 2)
- c) MSC sends APM message to originating MSC to inform its MSC address and call reference.
- d) MSC receives the selected transcoder types in MAP_TRANSCODER_Type_Notification message from originating MSC. MSC selects a transcoder type referring to the prioritised transcoder list from both originating MT and terminating MT. If necessary, MSC notifies selected transcoder type to the terminating MT and executes access link modification procedure with the bearer capability that supports selected transcoder type.
- e) MSC sends the selected transcoder type to originating MSC using MAP_TRANSCODER_Type_Modification message.
- f) MSC receives the selected transcoder type from originating MSC that carried by MAP_TRANSCODER_Type_Modify_ack message. If selected transcoder in the originating MSC is the same as the transcoder selected by the terminating MSC, it means that the originating MSC established the appropriate RAB and transcoder in the originating MSC could be avoidable. If the other transcoder is selected, it means the originating MSC failed to establish the appropriate RAB. In this case, terminating MSC has to abandon to avoid the transcoder either.
- g) When MSC receives CONNECT message from MT, MSC sends ANM message to originating MSC and transcoder avoiding procedure is executed if possible.

7.4 Out-of-band transcoder control (Alternative 3)

There are two steps for negotiation in this scenario. Firstly, the originating MSC informs its MSC address and call reference information to the terminating MSC using IAM message. The MSC address is conveyed using the generic number parameter. In order to use generic number parameter for MSC address, new number has to be assigned to the number qualifier indicator that manages the information of generic number.

Secondly, terminating MSC starts negotiation with originating MSC using newly defined MAP message. MAP_TRANSCODER_Notification message and MAP_TRANSCODER_Modification message need to be created for transcoder negotiation.

If this technique is deployed in the GSM network, the interworking with GSM system is possible and this results that the transcoders in the network can be avoided in case of the GSM-UMTS call connection. If this technique is not deployed in the GSM network, FFS is required.

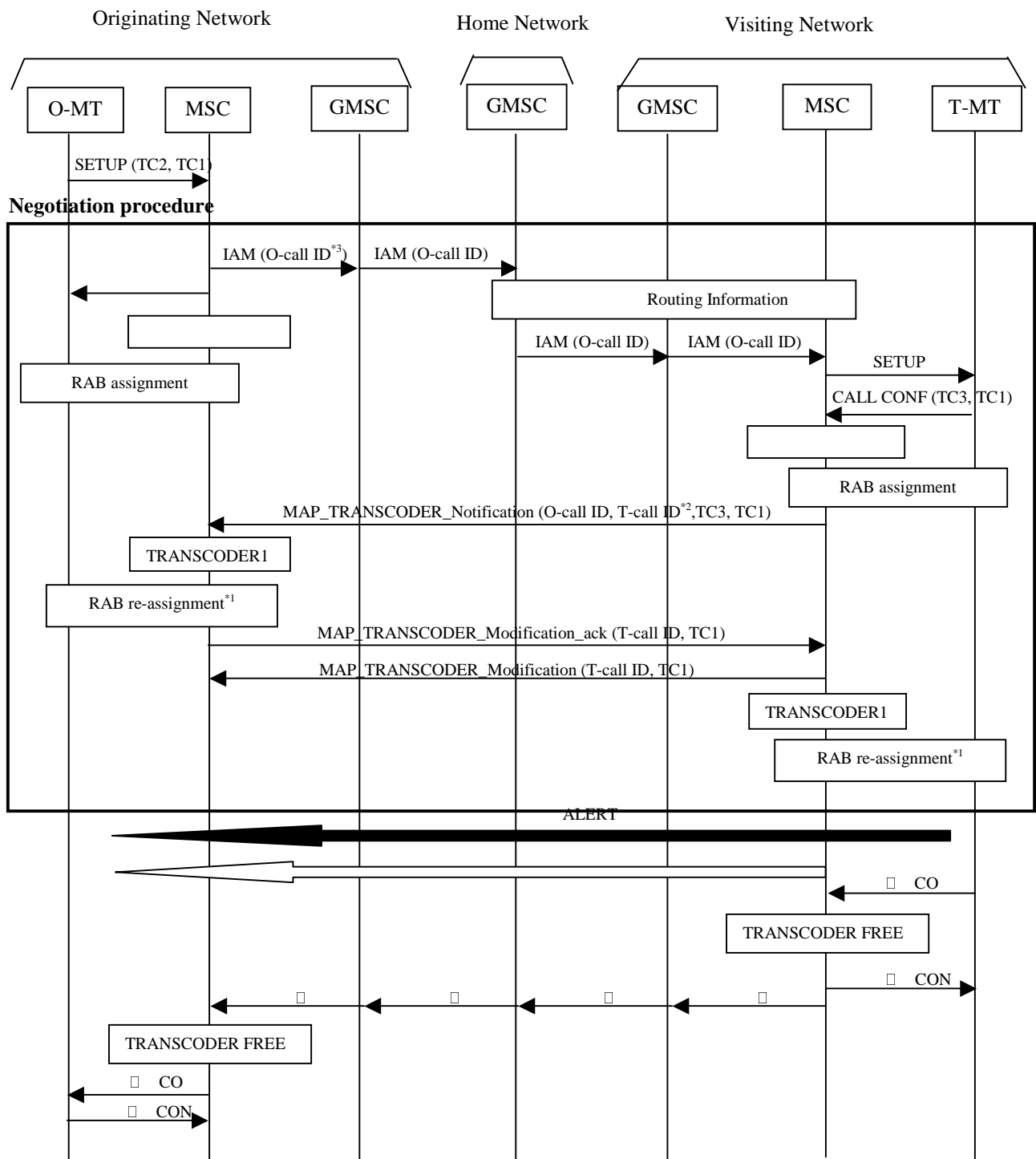

TC1, TC2 and TC3 are the types of the transcoder.

*1 If selected transcoder type isn't the first candidate of transcoder type.

*2 T-call ID: Terminating MSC address and call reference.

*3 O-call ID: Originating MSC address and call reference.

Figure 7.4: Out-of-band transcoder control (Alternative 3)

1. Procedures in the originating network

- a) MT sends SETUP message that includes “transcoder type list” in “bearer capability” parameter to MSC. “Transcoder type list” indicates transcoder types supported by the originating mobile terminal with preferable order. (E.g. speech version 1, then speech version 2)
- b) When MSC receives SETUP message from MT, MSC memorises the “transcoder types” and MSC executes access link set-up procedure to establish access link between mobile terminal and MSC with default bearer capability based on the received SETUP message.
- c) MSC sends IAM message to terminating MSC with its MSC address and call reference information and specifying the 64kbps UDI bearer for speech path establishment. If REL message is returned because of difficulty for providing UDI path in the transit network, MSC retries to send IAM message again with specifying speech bearer.
- d) When MSC receives terminating “transcoder types” in MAP_TRANSCODER_Type_Notification message from terminating MSC, MSC selects a transcoder type referring to the prioritised transcoder list from both originating MT and terminating MT. If necessary, MSC notifies selected transcoder type to the originating MT and executes access link modification procedure with the bearer capability that supports selected transcoder type.
- e) MSC sends the selected transcoder type to terminating MSC using MAP_TRANSCODER_Type_Modification message.
- f) MSC receives the selected transcoder type from terminating MSC that carried by MAP_TRANSCODER_Type_Modification_ack message. If selected transcoder in the terminating MSC is the same as the transcoder selected by the originating MSC, it means that the terminating MSC established the appropriate RAB and transcoder in the terminating MSC could be avoidable. If the other transcoder is selected, it means the terminating MSC failed to establish the appropriate RAB. In this case, originating MSC has to abandon to avoid the transcoder either.
- g) When MSC receives ANM message from terminating MSC, transcoder avoidance procedure is executed if possible.

2. Procedures in the terminating network

- a) When MSC receives IAM message from originating MSC, MSC sends SETUP message to MT.
- b) MSC receives CALL CONFIRM message which includes “transcoder type list” in “bearer capability” parameter from MT. “Transcoder type list” indicates transcoder types supported by the terminating mobile terminal with preferable order. (E.g. speech version 1, then speech version 2)
- c) MSC sends MAP_TRANSCODER_Type_Notification message to originating MSC to indicate the terminating transcoder types and executes access link set-up procedure to establish access link between mobile terminal and MSC with default bearer capability.
- d) MSC receives the selected transcoder types in MAP_TRANSCODER_Type_Modification message from originating MSC. MSC selects a transcoder type referring to the prioritised transcoder list from both originating MT and terminating MT. If necessary, MSC notifies selected transcoder type to the terminating MT and executes access link modification procedure with the bearer capability that supports selected transcoder type.
- e) MSC notifies the selected transcoder type to the originating MSC using MAP_TRANSCODER_Type_Modify_ack message.
- f) When MSC receives CONNECT message from MT, MSC sends ANM message to originating MSC and transcoder avoidance procedure is executed if possible.

7.5 Out-of-band transcoder control (Alternative 4)

- The Bearer Independent Call Control (BICC) protocol, which is being specified in ITU-T SG-11, supports transcoder negotiation capability. BICC can be used to support transcoder free operation, and provides smooth interworking with STM environments.

7.5.1 UMTS UE – UMTS UE call, APM possible in the whole path of the call

This subsection covers the case when the BICC protocol is used from O-MSC to T-MSC. That means the APM mechanism is supported in all the networks in the path of the MS-MS call.

The case with BICC and ISUP interworking, with ISUP either supporting APM or being able to convey it as unrecognised information (appropriate action indicators), is identical from the standpoint of end-to-end negotiation. In such a scenario, however, transcoding is required at the border between BICC and ISUP (TDM).

In this MS-MS call case, transcoder-free operation is achievable by out-of-band end-to-end codec negotiation. Figure 7.5.1 illustrates the signalling sequence including MS-CN and CN-CN interfaces. The list of codecs provided by O-UE, in the SETUP message, is analysed in all the BICC nodes participating in the negotiation. Non-supported codec options are removed from the list in each of these BICC nodes. The T-UE is passed the available codec list in the SETUP message, and selects the codec option (code x) in the received list that has higher preference level. Codec x selection is returned to the T-MSC in the Call confirm message, and carried back to the O-MSC in an APM message. In those sections in the network using BICC, the bearer connection for the call with codec x is established upon receiving the APM message. The bearer has to be set up after receiving the APM (codec x) message because the size of the bearer is dependant upon the codec selected. The O-UE is informed of the selected transcoder in the PROGRESS message, and RAB assignment will occur.

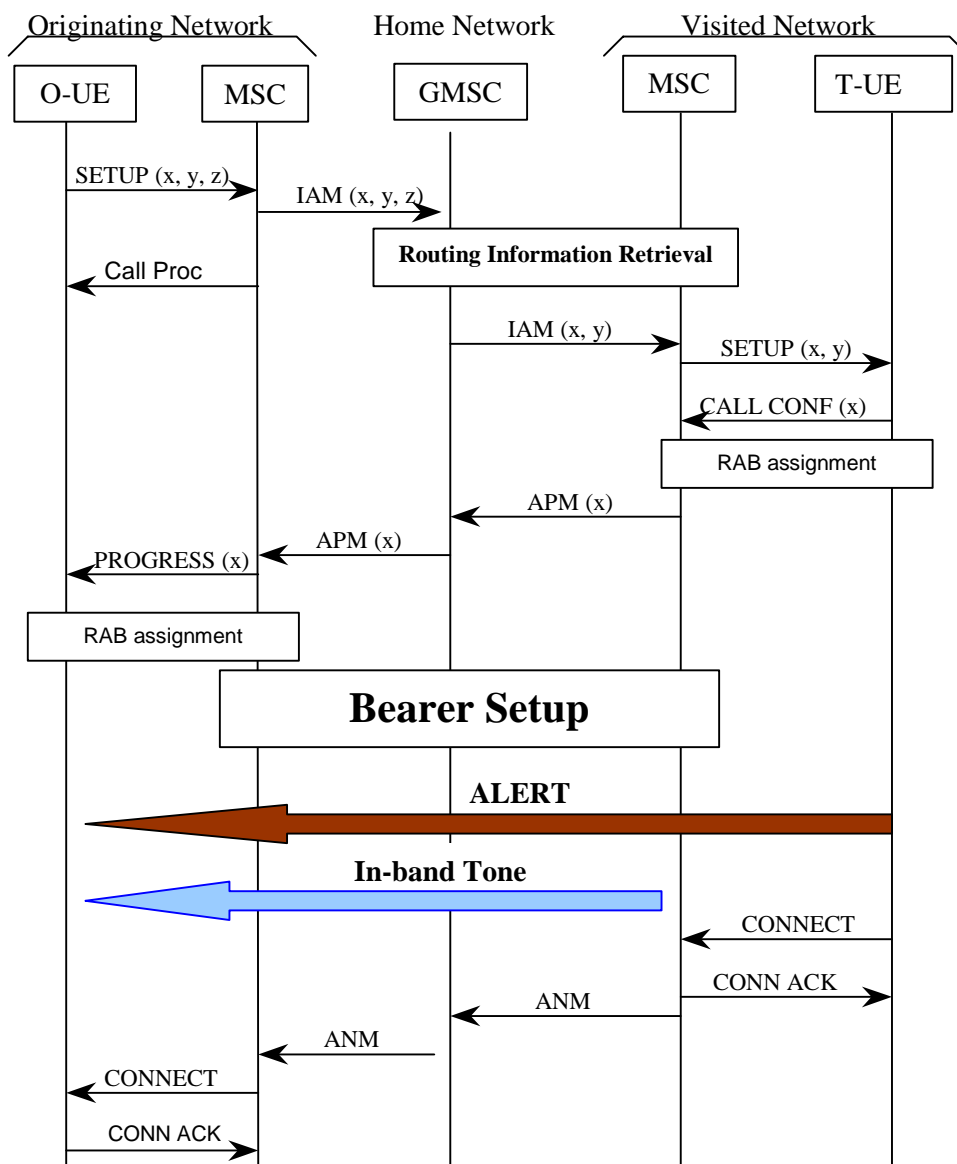

Figure 7.5.1: UMTS UE - UMTS UE call, BICC from O-MSC to T-MSC

7.5.2 UMTS MS – UMTS MS call, APM not possible in the whole path of the call

This subsection covers the case when the APM mechanism is not possible end-to-end because it is not supported in a transit network. In the case of a STM core network, either ISUP can support the transport of the APM mechanism, which can be used to increase the chance of TFO occurring, or if the APM mechanism is not supported, transcoding is applied without indication from the terminating subscriber/network.

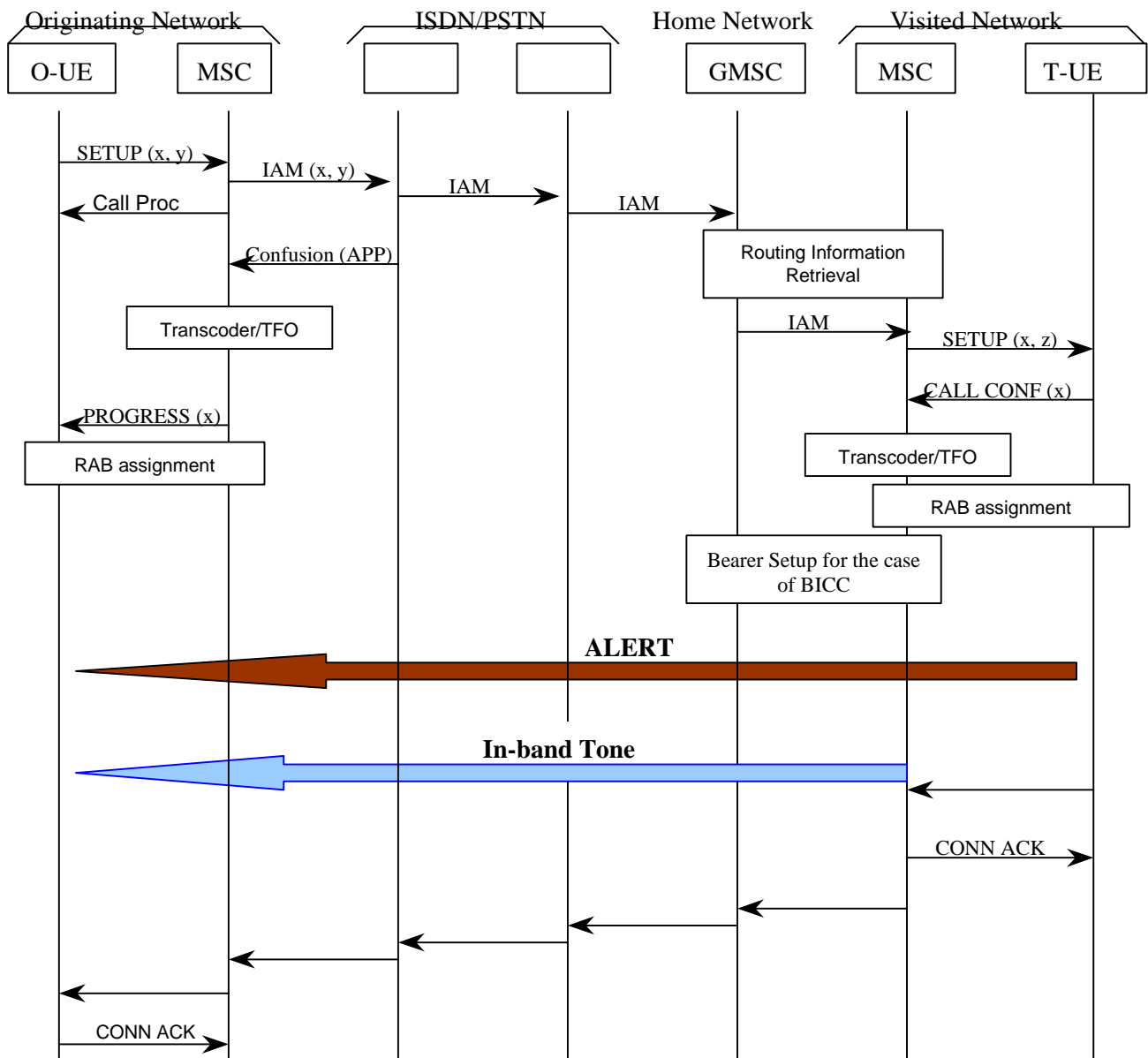

Figure 7.5.2: UMTS UE – UMTS UE call with transit network (PSTN/ISDN) not supporting

In this MS-MS call case, transcoder-free operation is not possible. The only choice is to use TFO to avoid quality degradation, if it can occur (i.e. allocation of transcoders is such that TFO operation can be invoked between the transcoders). Figure 7.5.2 illustrates the CC signalling sequence including UE-CN and CN-CN interfaces. The originating MSC sends an ISUP-IAM to the ISDN/PSTN with the application transport parameter (APP) containing the data needed for codec negotiation. The “pass-on not possible” indicator in the compatibility information of this APP is set to “discard parameter” and the “send notification indicator” is set to “send notification”. ISDN/PSTN does not support APM, so the APP is unrecognised at the entry node to the PSTN/ISDN.

If unrecognised information is not allowed in the ISDN/PSTN, the entry node will follow the “pass-on not possible” indicator and send a “confusion” message to the O-MSC indicating that the APP parameter was discarded. Upon reception of the “confusion” message, the O-MSC knows that out-of-band codec negotiation is not possible end-to-end.

The case when the APM mechanism is supported in the ISDN/PSTN transit network but not the APM-user that performs codec negotiation is solved in a similar way by setting the ATII (application transport instruction indicators) to the appropriate values. In this case the notification is carried out at the APM level. This case is covered in §0.

In the case where the terminating network supports BICC, and GMSC will include a list of codecs it can support in order to achieve low bit rate encoded speech in the terminating core network.

7.5.3 UMTS UE – GSM UE call

Current GSM networks do not support the out-of-band speech codec negotiation. The only choice is to use TFO, where possible, to avoid quality degradation (i.e. allocation of transcoders is unavoidable). Figure 7.5.3 illustrates the CC signalling sequence including MS-CN and CN-CN interfaces. Here, the APM mechanism and the APM-user are supported by BICC transit networks¹ but not by the GSM network where the called party is located. The destination GSM network supports APM but not the APM-user that performs speech codec negotiation. In this case, the MSC will follow the actions indicated in the application transport instruction indicators (ATII) of the APPs in the IAM message, which should be set to continue the connection but notify the peer. Another possibility is that the APM-user is actually supported but it is configured to not carry out negotiation (it may perform other functions as well), in this case the APM-user will implement procedures to deny such negotiation (which is shown in §0).

¹ All the networks (originating, transit and terminating) in figure 7.5.3 are BICC-based. The case of BICC-ISUP interworking is identical from the standpoint of end-to-end speech codec negotiation.

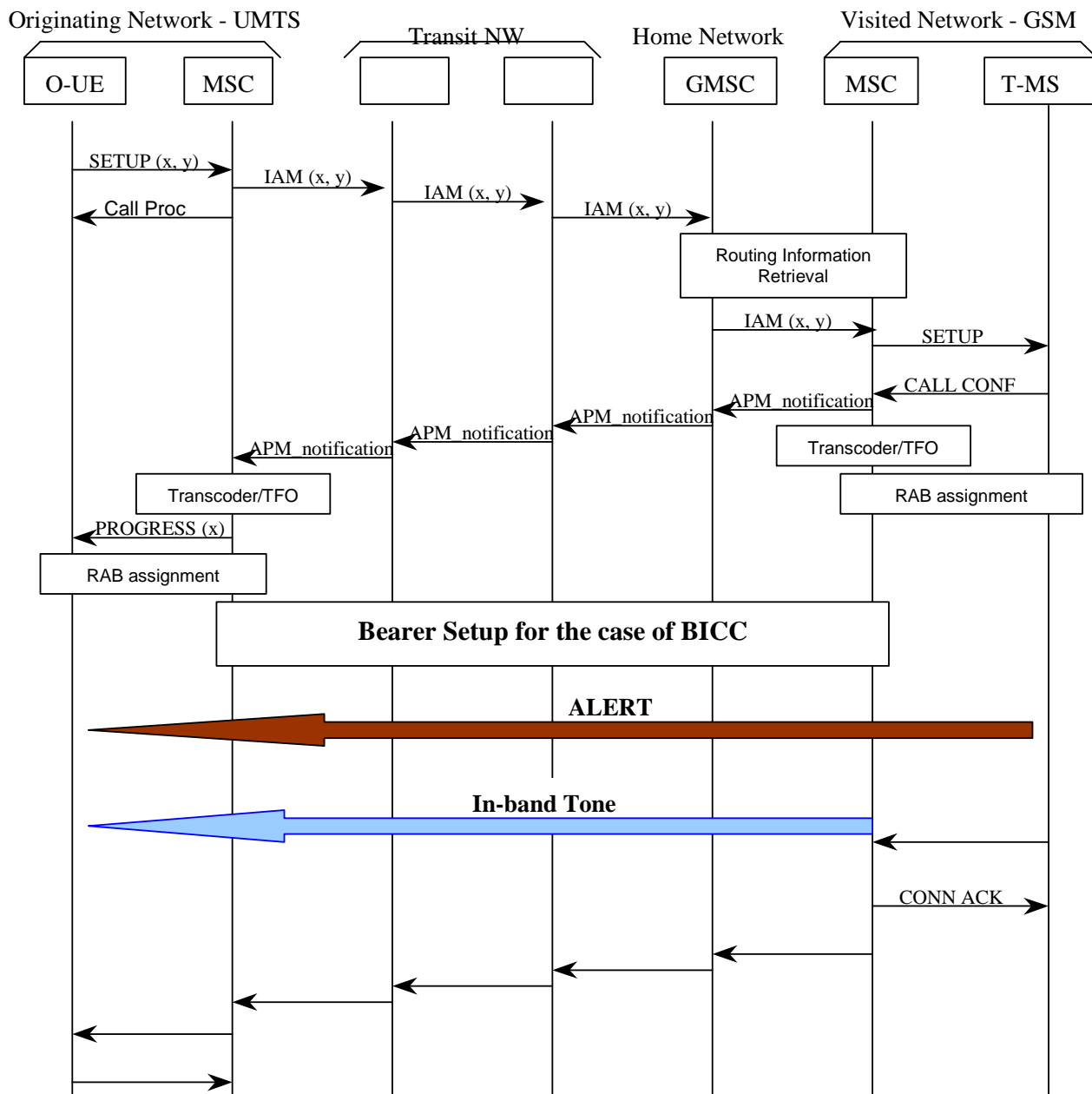

Figure 7.5.3: UMTS UE → GSM MS call, APM-user not supported in the GSM

Figure 7.5.4 illustrates the case when the call is established from a GSM MS to a UMTS MS. Note that, although there is no list of speech codecs in the incoming IAM message. The UMSC and the UE locally negotiate a speech codec for this call.

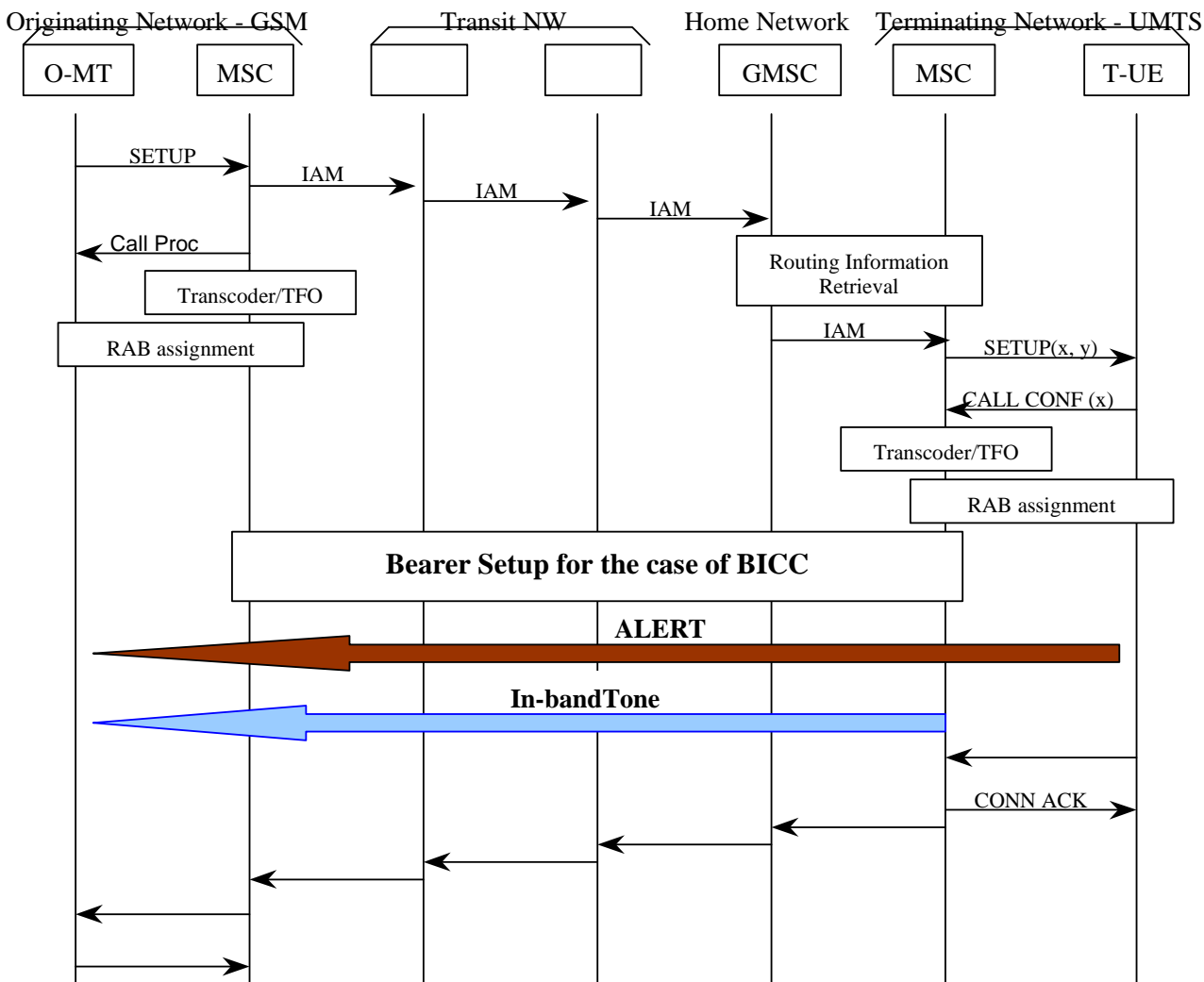

Figure 7.5.4: GSM MS →UMTS UE call, APM-user not supported in the GSM network

7.5.4 GSM MS to UMTS UE call, APM supported in GSM

The signalling flow in figure 7.5.5 below shows the case when the GMSC includes transcoding functionality. Here, the U-CN is non-TDM based (e.g. it uses AAL2 at the transport level). The transcoder/TFO for the UMTS side of the call is allocated in the terminating GMSC thus allowing significant bandwidth savings inside the UMTS core network.

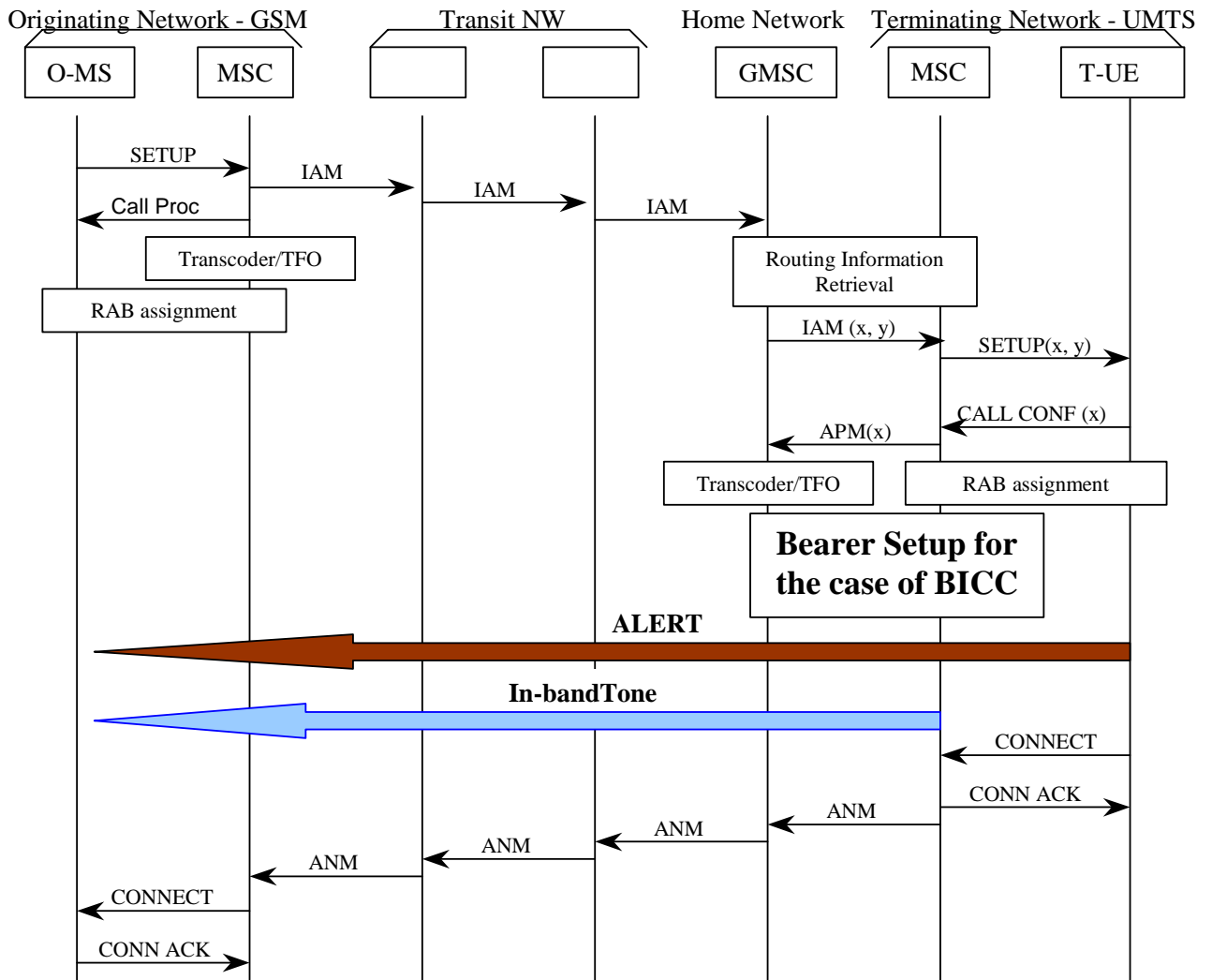

Figure 7.5.5: GSM MS →UMTS UE call, APM-user not supported in the GSM network

7.5.5 Handover from UMTS to GSM, after end-to-end transcoder free operation establishment

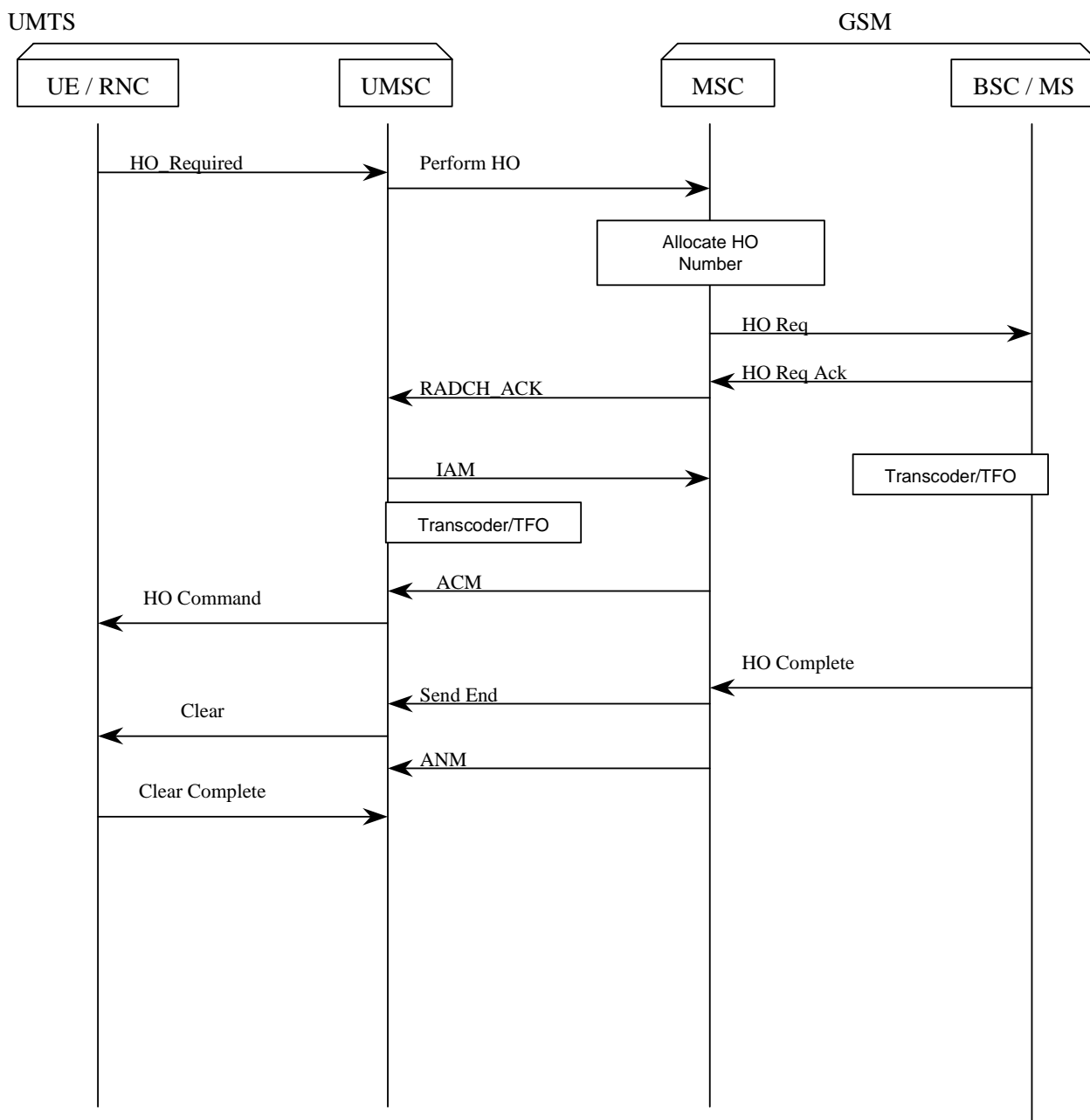

Figure 7.5.6: UMTS → GSM Handover after transcoder free establishment

Figure 7.5.6 illustrates the way that transcoding will be handled for inter MSC Handover from UMTS to GSM. If the transport link between the UMSC and the MSC is TDM, then the UMSC will transcode to PCM. The GSM BSC will perform transcoding in the same manner which currently used in GSM. TFO can be used to reduce quality degradation.

If the transport link between the UMSC and MSC is not TDM (e.g. AAL2 is supported), then the codec negotiation between the UMSC and MSC will be performed using the procedures shown in §0. In this case, the MSC will transcode from low bit rate speech to PCM across the GSM A-interface. The BSC will order the transcoding according to normal operation.

8 Comparison of proposed procedures

This section compares each proposed procedure from various different points of view and assesses the feasibility on specific point of view. Basically, the observation in this section is made based on the service requirements that described in section 5.

8.1 Service limitations

8.1.1 Network to be applied

<<Disadvantage>> [In-band TFO].

In-band TFO is basically created on the STM 64kbps UDI network as the transit network. Therefore, the service that requires wider than 64kbps bearer bandwidth cannot utilise this mechanism. On the other hand, the out-of-band transcoder control is independent from the structure of the call connection path.

<<Disadvantage>> [In-band TFO].

In-band TFO is basically created on the STM 64kbps UDI network as the transit network. Therefore, the fixed transmission bandwidth (i.e. 64kpbs) in the transit network cannot be optimised (minimised) even the low bit rate coding (e.g. 8kbps or 16kbps) is adapted in the transcoder avoiding connection.

<<Advantage>> [Out-of-band Alt.4].

Since this technique has an ability to negotiate transcoder types not only end node to end node but also end node to transit node, a part connection path of the overall call can configure the transcoder avoiding connection and this causes the bandwidth savings.

<<Advantage>> [Out-of-band Alt.4].

Since this technique targets not only 3GPP/IMT-2000 but also inter IMT-2000 families, it would be possible to establish transcoder avoiding connection between 3GPP/IMT-2000 and other IMT-2000 families if this technique is used both IMT-2000 networks and transit network.

8.2 Impacts on the current system

8.2.1 Impacts to the current GSM system

<<Advantage>> [In-band TFO].

Basically, this technique has a compatibility with the TFO that has been used by the current GSM system so that the transcoder avoiding connection may be established between IMT-2000 system and current GSM system if both systems use this technique.

8.2.2 Impacts to the specifications

<<Disadvantage>> [Out-of-band Alt.4].

The following table illustrates the specifications to be impacted by each technique.

The out-of-band Alt.4 has many impacts to the existing specifications that managed by outside of the 3GPP organisation if compared with other alternatives.

Proposed technique	Modifications	Specifications to be impacted
In-band TFO (Enhancement)	Add new codec types	In-band TFO spec. stage 2 (3GPP) In-band TFO spec. stage 3 (3GPP)
Out-of-band (Alternative 1)	Add new application to APM message Define new parameter that carries transcoder_type_list on APM message	N-ISUP specifications (ITU-T)
Out-of-band (Alternative 2)	Add new application to APM message Add new number qualifier indicator to the Generic number field to carry MSC address Add new MAP messages and parameters	N-ISUP specifications (ITU-T) MAP specification : 29.002 (3GPP)
Out-of-band (Alternative 3)	Add new parameter to IAM message Add new number qualifier indicator to the Generic number field to carry MSC address Add new MAP messages and parameters	N-ISUP specifications (ITU-T) MAP specification : 29.002 (3GPP)
Out-of-band (Alternative 4)	Add new application to APM message Add new parameter to IAM message Introduce BICC standard to the network	N-ISUP specifications (ITU-T) : (add new messages) New BICC specifications (ITU-T) Specification regarding to the signalling with external network (3GPP)

8.2.3 Punctuality for Release 99

<<Disadvantage>> [Out-of-band Alt.4] > [Out-of-band Alt.1,2] > [Out-of-band Alt.3].

In case that the specifications to be impacted are not only within the 3GPP specifications, the expected time scale set in the 3GPP cannot be guaranteed. In this sense, the in-band TFO has an advantage since only 3GPP specifications may be impacted. The out-of-band Alt.3 has an advantage than other out-of-band alternatives since there are fewer impacts to the ITU specifications than other alternatives.

8.3 Configuration

8.3.1 Hardware configurations

<<Disadvantage>> [In-band TFO].

Since TFO transcoder has to monitor the TFO message in the PCM form, TFO transcoder cannot be released even transcoder avoiding connection has been established. This limitation requires MSC to have unnecessary transcoders.

8.4 Quality of service

8.4.1 Transmission quality

<<Disadvantage>> [In-band TFO].

In order to communicate between MSCs using in-band TFO message, one bit out of 16 LSB bits is regularly stolen of the 64kbps circuit. This may cause the degradation of communication quality. Especially, in case of high rate data communication such as modem, PPP and PIAFS, this expected bit error might cause disability of communication.

8.5 Maintenance for future expansion

8.5.1 Transcoder type addition

<<Disadvantage>> [In-band TFO].

In order to add new transcoder type in future, all transcoder, circuit by circuit has to be upgraded to accommodate with new transcoder type.

8.5.2 Transcoder reallocation

<<Advantage>> [Out-of-band Alt.4].

The transcoder reallocation is currently studied in the TSG-SA2 (To reallocate transcoder to the edge of the network for the efficient usage of network resources). The out-of-band Alt.4 has much flexibility for this transcoder reallocation because this technique has an ability to negotiate transcoder types not only end node to end node but also end node to transit node.

9 Conclusion

The first judgement has to be made comparison between In-band TFO and Out-of-band transcoder control. It is concluded that the out-of-band transcoder control has more advantages than in-band TFO because of following reasons:

- The out-of-band transcoder control is more cost beneficial than in-band TFO because of the reason described in section 8.3.1.
- There should be a common procedure that can handle all transcoders (including multimedia transcoders) in the network. In this sense, the in-band TFO has a fatal limitation to support multimedia transcoders (i.e. section 8.1.1).

Secondary, the most feasible out-of-band transcoder procedure from four alternatives has to be found. The important facts for consideration are:

- (1) The procedure has to have enough adaptability for the future network structure.
- (2) The procedure has to be met for release 99.

The Out-of-band Alt.4 is the most feasible technique for UMTS/IMT-2000.

The reasons for this conclusion are:

- The Out-of-band Alt.4 have enough adaptability for the future network structure. (i.e. 8.5.2) Moreover, Compatibility for interworking with other IMT-2000 seems much beneficial in future. (i.e. The last item in the 8.1.1).
- The result of the Interim ITU-T SG11 WP1 meeting was reported in the TSG-CN WG2 meeting in 19th July 1999 as follows: Therefore, it is concluded that the out-of-band Alt.4 could meet the time scale for release 99.
 - The concept of the BICC was accepted in the Interim ITU-T SG11 WP1 meeting.
 - The draft version of the BICC specification would be released in December 1999.

Annex A (informative): Change history

Change history						
TSG CN#	Spec	Version	CR	<Phase>	New Version	Subject/Comment
CN#05	23.911	3.0.0		R99		Version 3.0.0 created (October 1999)
	23.911	3.0.0		R99	3.0.1	Editorial clean-up by MCC

History

Document history		
V3.0.0	January 2000	Publication
V3.0.1	October 2001	Publication