

# ETSI TR 123 910 V3.6.0 (2002-09)

---

*Technical Report*

## **Universal Mobile Telecommunications System (UMTS); Circuit switched data bearer services (3GPP TR 23.910 version 3.6.0 Release 1999)**

---



---

Reference

RTR/TSGN-0323910v360

---

Keywords

UMTS

**ETSI**

650 Route des Lucioles  
F-06921 Sophia Antipolis Cedex - FRANCE

Tel.: +33 4 92 94 42 00 Fax: +33 4 93 65 47 16

Siret N° 348 623 562 00017 - NAF 742 C  
Association à but non lucratif enregistrée à la  
Sous-Préfecture de Grasse (06) N° 7803/88

---

**Important notice**

Individual copies of the present document can be downloaded from:

<http://www.etsi.org>

The present document may be made available in more than one electronic version or in print. In any case of existing or perceived difference in contents between such versions, the reference version is the Portable Document Format (PDF). In case of dispute, the reference shall be the printing on ETSI printers of the PDF version kept on a specific network drive within ETSI Secretariat.

Users of the present document should be aware that the document may be subject to revision or change of status.

Information on the current status of this and other ETSI documents is available at

<http://portal.etsi.org/tb/status/status.asp>

If you find errors in the present document, send your comment to:

[editor@etsi.fr](mailto:editor@etsi.fr)

---

**Copyright Notification**

No part may be reproduced except as authorized by written permission.  
The copyright and the foregoing restriction extend to reproduction in all media.

© European Telecommunications Standards Institute 2002.  
All rights reserved.

**DECT™**, **PLUGTESTS™** and **UMTS™** are Trade Marks of ETSI registered for the benefit of its Members.  
**TIPHON™** and the **TIPHON logo** are Trade Marks currently being registered by ETSI for the benefit of its Members.  
**3GPP™** is a Trade Mark of ETSI registered for the benefit of its Members and of the 3GPP Organizational Partners.

---

## Intellectual Property Rights

IPRs essential or potentially essential to the present document may have been declared to ETSI. The information pertaining to these essential IPRs, if any, is publicly available for **ETSI members and non-members**, and can be found in ETSI SR 000 314: "*Intellectual Property Rights (IPRs); Essential, or potentially Essential, IPRs notified to ETSI in respect of ETSI standards*", which is available from the ETSI Secretariat. Latest updates are available on the ETSI Web server (<http://webapp.etsi.org/IPR/home.asp>).

Pursuant to the ETSI IPR Policy, no investigation, including IPR searches, has been carried out by ETSI. No guarantee can be given as to the existence of other IPRs not referenced in ETSI SR 000 314 (or the updates on the ETSI Web server) which are, or may be, or may become, essential to the present document.

---

## Foreword

This Technical Report (TR) has been produced by ETSI 3rd Generation Partnership Project (3GPP).

The present document may refer to technical specifications or reports using their 3GPP identities, UMTS identities or GSM identities. These should be interpreted as being references to the corresponding ETSI deliverables.

The cross reference between GSM, UMTS, 3GPP and ETSI identities can be found under [www.etsi.org/key](http://www.etsi.org/key).

# Contents

Intellectual Property Rights .....	2
Foreword.....	2
Foreword.....	4
1 Scope .....	5
2 References .....	5
3 Definitions and abbreviations.....	6
3.1 Definitions .....	6
3.2 Abbreviations .....	6
4 General .....	7
4.1 Limited set of UMTS PLMN connection models.....	8
4.1.1 Transparent data.....	8
4.1.2 Non-transparent data.....	9
5 UMTS Bearer Services.....	9
5.1 UMTS Bearer Services in Release 99 .....	9
5.1.1 Transparent Data.....	9
5.1.2 Non-Transparent Fax .....	10
5.1.3 NT Data .....	10
5.1.4 Transparent Data for Support of Multimedia.....	10
5.2 BC-IE to RAB QoS Mapping.....	10
5.2.1 Non-transparent services.....	11
5.2.2 Transparent Data, including Multimedia .....	11
6 Iu User Plane .....	12
6.1 NT services.....	12
6.2 T services.....	12
6.2.1 Avoidance of delay at RNC .....	12
6.2.2 Recovery from the loss of ATM cells.....	12
7 RLC .....	13
8 Initial Synchronisation and resynchronisation .....	13
8.1 Modem services (3.1 kHz audio).....	13
8.1.1 Transparent Case .....	13
8.1.2 Non-Transparent Case .....	13
8.2 Digital services .....	13
8.2.1 Transparent case .....	13
8.2.2 Non-Transparent case .....	14
8.3 Loss of synchronisation.....	14
9 Call Control.....	14
10 Handover Issues .....	14
10.1 Signalling issues.....	14
10.1.1 Loss of BC Information during Handover from GSM to UMTS.....	14
10.1.2 Handover from UMTS to GSM .....	14
10.2 User Plane .....	14
10.2.1 Handover from UMTS to GSM .....	14
10.2.2 Handover from GSM to UMTS .....	15
10.2.2.1 Frame layout for the different transparent user rates.....	15
10.2.2.2 A-TRAU' frame format .....	15
10.2.3 Handover within 3G PLMNs.....	17
10.2.4 Handover for 56kbit/s .....	18
<b>Annex A: Change history.....</b>	<b>19</b>
History .....	20

---

# Foreword

This Technical Report (TR) has been produced by the 3<sup>rd</sup> Generation Partnership Project (3GPP).

The contents of the present document are subject to continuing work within the TSG and may change following formal TSG approval. Should the TSG modify the contents of the present document, it will be re-released by the TSG with an identifying change of release date and an increase in version number as follows:

Version x.y.z

where:

- x the first digit:
  - 1 presented to TSG for information;
  - 2 presented to TSG for approval;
  - 3 or greater indicates TSG approved document under change control.
- y the second digit is incremented for all changes of substance, i.e. technical enhancements, corrections, updates, etc.
- z the third digit is incremented when editorial only changes have been incorporated in the document.

---

# 1 Scope

The present document provides an overview of the architecture and issues related to the provision of Circuit Switched Bearer Services in a 3G mobile network.

---

# 2 References

The following documents contain provisions which, through reference in this text, constitute provisions of the present document.

- References are either specific (identified by date of publication, edition number, version number, etc.) or non-specific.
- For a specific reference, subsequent revisions do not apply.
- For a non-specific reference, the latest version applies. In the case of a reference to a 3GPP document (including a GSM document), a non-specific reference implicitly refers to the latest version of that document in the same Release as the present document.

- [1] 3GPP TS 03.10: "GSM Public Land Mobile Network (PLMN) connection types".
- [2] 3GPP TR 21.905: "3G Vocabulary".
- [3] 3GPP TS 22.100: "UMTS Phase 1".
- [4] 3GPP TS 22.002: "Bearer Services Supported by a GSM PLMN".
- [5] 3GPP TS 22.101: "Service Principles".
- [6] 3GPP TS 22.105: "Services and Service Capabilities".
- [7] 3GPP TS 23.002: "Network Architecture".
- [8] 3GPP TS 23.034: "High Speed Circuit Switched Data (HSCSD) -Stage 2".
- [9] 3GPP TS 23.101: "General UMTS Architecture".
- [10] 3GPP TS 23.107: "Quality of Service, Concept and Architecture".
- [11] 3GPP TS 24.022: "Radio Link Protocol (RLP) for circuit switched bearer and teleservices".
- [12] 3GPP TS 25.322: "Radio Link Control (RLC) Protocol Specification".
- [13] 3GPP TS 25.415: "UTRAN Iu Interface user plane protocols".
- [14] 3GPP TS 27.001: "General on Terminal Adaption Functions (TAF) for Mobile Station (MS)".
- [15] 3GPP TS 29.007: "General Requirements on Interworking between the PLMN and the ISDN or PSTN".
- [16] ITU-T Recommendation V.90: "A digital modem and analogue modem pair for use on the Public Switched Telephone Network (PSTN) at data signalling rates of up to 56 000 bit/s downstream and up to 33 600 bit/s upstream".
- [17] VOID.
- [18] 3GPP TS 04.21: "Digital cellular telecommunications system (Phase 2+); Rate adaption on the Mobile Station - Base Station System (MS - BSS) interface".
- [19] 3GPP TS 08.20: "Digital cellular telecommunication system (Phase 2+); Rate adaption on the Base Station System - Mobile-services Switching Centre (BSS - MSC) interface".
- [20] ITU-T Recommendation I.366.1: "Segmentation and Reassembly Service Specific Convergence Sublayer for the AAL type 2".
- [21] ITU-T Recommendation Q.2630.1: "AAL Type 2 Signalling Protocol (Capability Set 1)".

---

## 3 Definitions and abbreviations

### 3.1 Definitions

For the purposes of the present document, terms and definitions given in 3GPP TS 21.905 [2] apply.

### 3.2 Abbreviations

For the purposes of the present document, the following abbreviations apply:

AAL2	ATM Adaptation Layer 2
AIUR	Air Interface User Rate
ATM	Asynchronous Transmission Mode
BC	Bearer Capability
BS	Bearer Service
BSSMAP	Base Station System Mobile Application Protocol
CE	Connection Element
CN	Core Network
CS	Circuit Switched
CT	Circuit
DCE	Data Communication Equipment
DTE	Data Terminal Equipment
DTX	Discontinuous Transmission
IE	Information Element
ITC	Information Transfer Capability
IWF	Interworking Function
MAP	Mobile Application Protocol
MSC	Mobile Services Switching Centre
MT	Mobile Termination
NT	Non-transparent
QoS	Quality of Service
RAB	Radio Access Bearer
RDI	Restricted Digital Information
RLC	Radio link control
RLP	Radio link protocol
RNL	Radio Network Layer
SAP	Service Access Point
SSCS	Service Specific Convergence Sublayer
SDU	Service Data Unit
T	Transparent
TAF	Terminal Adaption Function
TE	Terminal
UDI	Unrestricted Digital Information
UE	User Equipment
UP	User Plane
VLR	Visiting Location Register
WAIUR	Wanted Air Interface User Rate

# 4 General

CS data services in UMTS (UMTS Bearer Services) are build on services provided by the Access Network. These Radio Access Bearer Services are invoked through the RNL-SAP provided by the Iu User Plane to the Non-access stratum on the Core Network side, and the corresponding SAP provided by the RLC to the Non-access stratum on the Terminal side. Transport within the CN (the CN Bearer services) is outside the scope of this document. Interworking with External Bearer services is within the scope of this document. See figure 1.

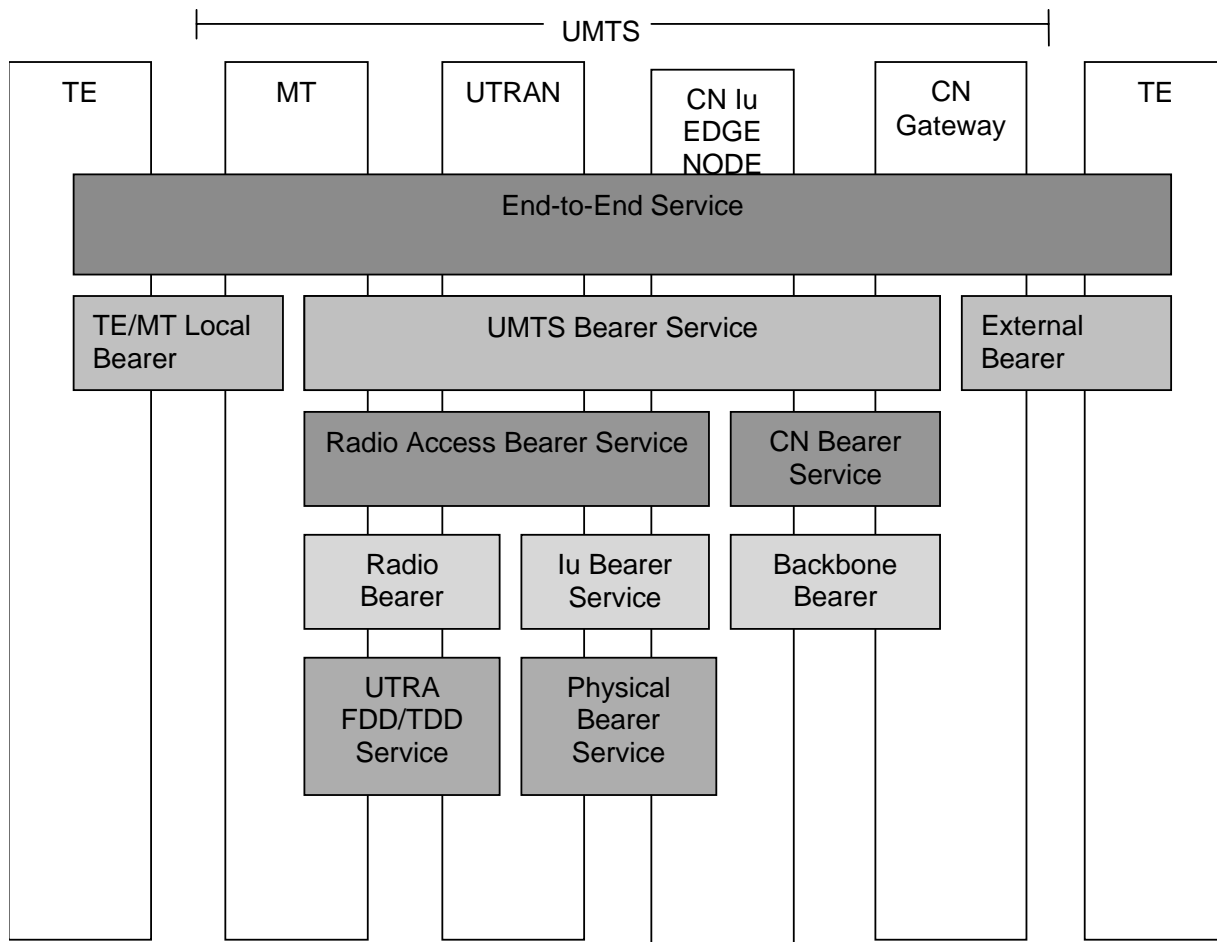

Figure 1



## 4.1 Limited set of UMTS PLMN connection models

### 4.1.1 Transparent data

Figure 2 shows the connection model for synchronous transparent CS data. In general all the user data bits are conveyed between the MT and the IWF as they are received from the TE. This implies that the RLC SDU/ Iu UP frame is transparent.

Figure 3 shows the connection model for asynchronous transparent CS data. The rate adaptation function RA0 from 3GPP TS 04.21 (adapted to the RLC SDU size) is used for converting between asynchronous data and a synchronous bit stream. End-to-end flow control is not applicable in UMTS, thus no status bits are conveyed over RAN/UTRAN (see 3GPP TS 27.001).

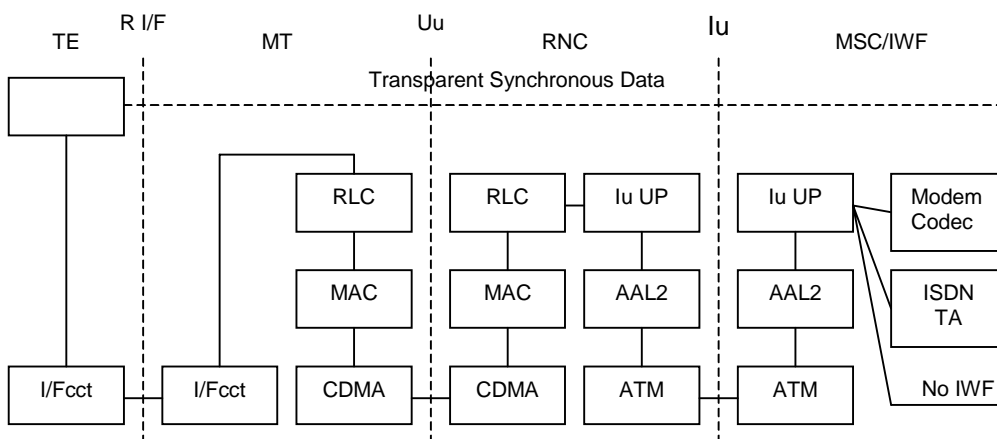

Figure 2 Connection model for Synchronous T CS data

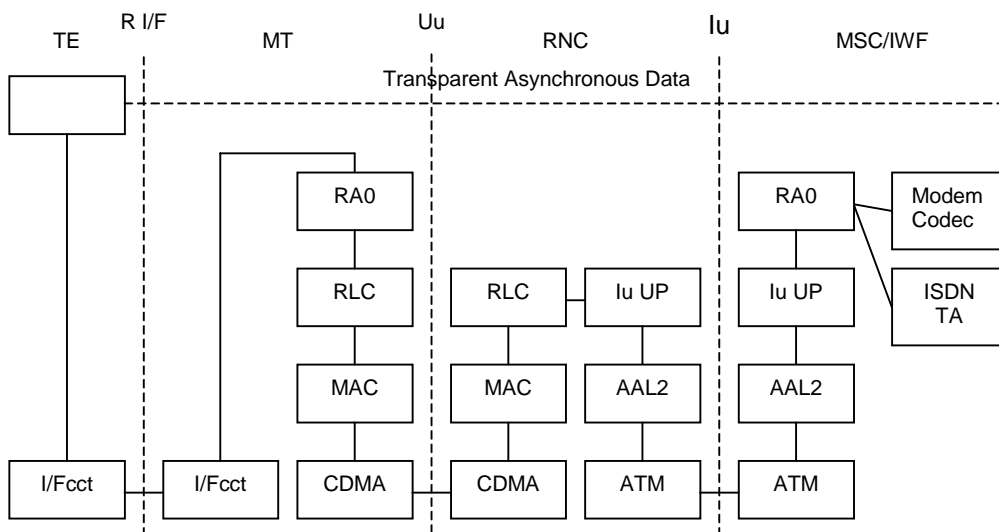

Figure 3 Connection model for Asynchronous T CS data

## 4.1.2 Non-transparent data

Figure 4 shows the connection model for asynchronous non-transparent CS data.

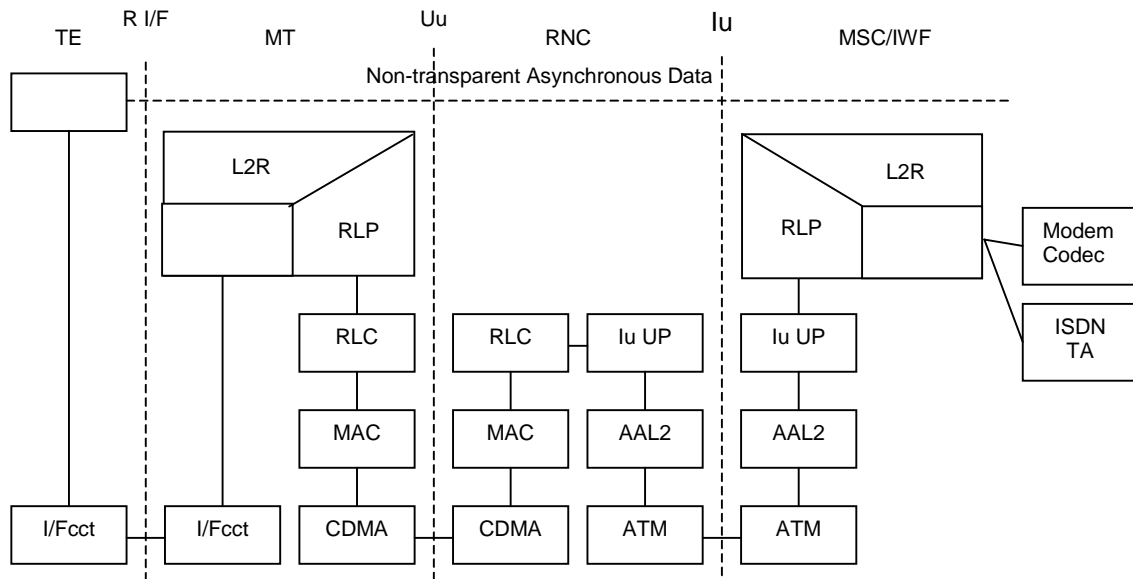

Figure 4 Connection model for Asynchronous NT CS data

## 5 UMTS Bearer Services

The UMTS bearer services are described by the UMTS BC-IE. Four services (or services categories) are currently distinguishable from the UMTS BC-IE:

- Speech.
- Transparent Data for support of Multimedia.
- Transparent Data.
- Non-transparent data.

Speech is currently not in the scope of the present document.

Each UMTS bearer service is supported by a Radio Access Bearers (RAB). The RABs in turn are described by the QoS parameters. There may be one or several RAB candidates for supporting a UMTS bearer service. The possible candidates are described by a mapping of the BC-IE to RAB QoS described in subclause 5.2.

### 5.1 UMTS Bearer Services in Release 99

#### 5.1.1 Transparent Data

This service is distinguished by the following BC-IE parameters:

- ITC = UDI or 3.1 kHz audio or Other ITC = RDI.
- CE = transparent.

For this service the FNUR at the setup is restricted to:

- 64 kbit/s, in case ITC = UDI.
- 56 kbit/s in case ITC = UDI or Other ITC = RDI.

- 28,8 kbit/s, in case ITC = 3,1 kHz audio.

NOTE: ITU-T V.90 [16] is not supported in transparent mode, because asymmetric user rates are not supported in transparent mode.

## 5.1.2 Non-Transparent Fax

Void.

## 5.1.3 NT Data

This service is distinguished by the following BC-IE parameters:

- ITC = UDI or 3.1 kHz audio or Other ITC = RDI.
- CE = non-transparent.

The possible AIURs are limited to 14,4 kbit/s, 28,8 kbit/s and 57,6 kbit/s.

## 5.1.4 Transparent Data for Support of Multimedia

This service is distinguished by the following BC-IE parameters:

- ITC = UDI or 3.1 kHz audio or Other ITC = RDI.
- CE = transparent.
- Other rate adaptation = H.223 and H.245.

For this service the FNUR at the setup is restricted to:

- 64 kbit/s, in case ITC = UDI.
- 56 kbit/s in case Other ITC = RDI.
- 33,6 kbit/s, in case ITC = 3,1 kHz audio.
- 32 kbit/s, in case ITC = UDI.
- 28,8 kbit/s, in case ITC = 3,1 kHz audio.

NOTE: Transmission rates 31.2 and 28.8 kbit/s negotiated by the modems in a 3.1 kHz multimedia call may be used with a rate adaptation to 33.6 kbit/s between the UE and the IWF (ref. to 3GPP TS 27.001 and 29.007). The negotiated values shall be provided by the MSC by way of a MODIFY message.

## 5.2 BC-IE to RAB QoS Mapping

Since UMTS bearer services are described by BC-IEs and RABs by QoS parameters, this section provides implicitly a mapping between the UMTS bearer services and the possible RABs that support them. The QoS mapping is based on TS 23.107.

## 5.2.1 Non-transparent services

Service identified by the BC IE	Non-transparent data	Comments
Traffic Class	Streaming	Subject to operator tuning
RAB Asymmetry Indicator	Symmetric	
Maximum bit rate (1)	14,4 kbit/s, 28,8 kbit/s, 57.6 kbit/s	Maximum bit rate is set to the highest value $\leq$ WAIUR (Note 1)
Guaranteed bit rate	14,4 kbit/s, 28,8 kbit/s, 57.6 kbit/s	Operator may choose any of the possible values less or equal to WAIUR. (Note 1)
Delivery Order	Yes	
Maximum SDU size	576 bits	
Transfer Delay	250 ms	Subject to operator tuning
Traffic Handling Priority	-	Not applicable to the streaming traffic class
Source statistics descriptor	Unknown	
SDU Parameters		
Residual bit error ratio	$10^{-3}$	Subject to operator tuning.
Delivery of erroneous SDUs	No error detection consideration	
SDU format information		
RAB Subflow Combination bit rate	57,6 kbit/s	(Note 2)
RAB Subflow Combination bit rate	28,8 kbit/s	(Note 2)
RAB Subflow Combination bit rate	14,4 kbit/s	
RAB Subflow Combination bit rate	0 kbit/s	indicates DTX, RFCI is not assigned
NOTE 1: If WAIUR is less or equal to 14.4 kbit/s then GBR and MBR shall be set to 14.4 kbit/s.		
NOTE 2: Only RAB subflow combination bit rates $\leq$ maximum bit rate shall be specified.		

## 5.2.2 Transparent Data, including Multimedia

Service identified by the BC IE	Transparent data and BS for support of multimedia service	Comments
Traffic Class	Conversational	Subject to operator tuning
Maximum bit rate	= guaranteed bit rate	
Guaranteed bit rate	FNUR = 64 .. 28.8 kbit/s (Note 2)	GBR for FNUR=56 kbit/s is 64 kbit/s (Note 1)
Delivery Order	Yes	
Maximum SDU size	640 bits for FNUR=32, 56 and 64 kbit/s 576 bits for FNUR=28.8 kbit/s	(Note 3)
Transfer Delay	< 200 ms	Subject to operator tuning
Traffic Handling Priority	-	Not applicable for the conversational traffic class
Source statistics descriptor	Unknown	
SDU Parameters		
SDU error ratio	-	Not applicable
Residual bit error ratio	$10^{-4}$	Subject to operator tuning according to 3GPP TS 23.107. Operator may also choose different value for Multimedia and other transparent data services.
Delivery of erroneous SDUs	-	No error detection in the core network

NOTE 1: In case the FNUR = 56 kbit/s, the GBR is set to 64 kbit/s. Last bit in each data octet is set to 1.

NOTE 2: If the FNUR is changed as a result of a MODIFY procedure during the call, the guaranteed bit rate is not changed.

NOTE 3: The maximum SDU size for FNUR=33.6 kbit/s is still under discussion.

## 6 Iu User Plane

### 6.1 NT services

The Iu user plane is used in support mode, see 3GPP TS 25.415. Each SDU corresponds to one RLP frame and, consequently, is 576 bits long. Each SDU is transported in one Iu UP PDU of Type 1. The range of AIUR values is 14,4, 28,8, 57,6, limited by the maximum bit rate, and varies with the transmission period on the Uu interface, which is 10 ms, 20 ms or 40 ms. The Iu UP signals to the CN when the transmission period changes. The Iu UP primitive Iu-UP-DATA-REQUEST is invoked each time an RLP frame is ready to be sent from the CN towards the UE. DTX indication is not used.

### 6.2 T services

The Iu UP is used in transparent mode, see 3GPP TS 25.415. The payload of the Iu frame will consist of user data bits only for synchronous data, and RA0 synchronous bit streams for asynchronous data.

The payload (SDU) size is fixed, determined by the bit rate. Following table shows SDU size defined by GSM Association - IMT-2000 Steering Group (Typical Radio Interface Parameter Sets). AAL2 is used. The AAL2 SSCS layer must be supported for segmentation and re-assembly.

Bit rate	SDU size (= RLC PDU payload size)
28.8 kbit/s	576 bits
33.6 kbit/s	[Editor's note] Waiting for decision by GSM Association
32 kbit/s	640 bits
56/64 kbit/s	640 bits

The primitive Iu-UP\_UNIT-DATA-REQUEST is invoked at regular intervals in order to have a constant bit rate (every SDU).

#### 6.2.1 Avoidance of delay at RNC

The TTI-to-CPS Packet packaging delay can be avoided by choosing the length of the CPS packet payload so that the payloads of an integer number of CPS Packets fill one TTI. The contents of the whole TTI can be sent further towards the MSC immediately after the reception without waiting for the next TTI.

#### 6.2.2 Recovery from the loss of ATM cells

The ATM cell loss rate is estimated to be very small (less than  $10^{-6}$  ...  $10^{-8}$ ), the quality of transmission being comparable to that of a high quality ISDN.

The following happens if a cell is lost (ref. to I.363.2):

- At least one CPS packet is distorted.
- The distorted CPS packet(s) is/are discarded by the receiver.
- If only one CPS packet is discarded, the upper layer can identify the event by the UUI/SSSAR sequence number, and consequently insert a fill sequence of the length of a CPS payload field to the correct place in the bit stream. I.366.1[20] (SSSAR) describes that UUI takes value between 0 and 26 for final data and value 27 for more data, but UUI should take value 26 for final data considering compatibility with other SSCS specifications. When UUI works as sequence number by repetition of 27 and 26, CPS packet payload size is equal to half a SDU size. This

CPS packet payload size also satisfies the requirement described in subclause 6.2.1. CPS packet payload size is set by Q.2630.1[21] over Iu interface.

- If more than one CPS packets are discarded, the upper layer can identify the event by monitoring the buffer level at the ATM/TDM interface or by monitoring the reception of CPS packets with a timer. (The modulo 2 sequence number cannot indicate the loss of two consecutive CPS packets). The following figures apply for the 40 octet payload field.
- Worst case: 2 packets lost =>  $2 * 40 \text{ octets} * 8 \text{ bits/octet} : 64 \text{ kbit/s} = 10 \text{ ms}$ , i.e. buffer level decreased by 80 octets.
- Consequently, recovery with fill inserted in the correct place is possible, if the ATM cell jitter (i.e. transmission delay variation) is less than 5 ms. With a bigger jitter fill may be inserted in a wrong place in the TDM bit stream.

---

## 7 RLC

The RLC shall be used in transparent mode for T and NT services.

---

## 8 Initial Synchronisation and resynchronisation

### 8.1 Modem services (3.1 kHz audio)

#### 8.1.1 Transparent Case

The IWF does not send any SDUs down link until the modem connection has been established and the modems have synchronised. Thereafter the IWF through connects, mapping data from the fixed network side onto SDUs that are sent toward the MS, and mapping data in the received SDUs to the fixed network side.

The MS sends no SDUs until an SDU is received at the transmission SAP. Until the first access stratum SDU is received, CT 106, 107 and 109 remain in the OFF condition. At the reception of the first SDU, CT 106, CT 107 and CT 109 are changed from OFF to ON at the DCE/DTE (TE/TAF) interface. The data in the received SDUs are mapped to CT 104 and data on CT 103 are mapped to SDUs sent toward the RNC.

#### 8.1.2 Non-Transparent Case

At the IWF, the synchronisation of modems on the transit network is performed after establishment of the physical connection. The RLP establishment may be initiated by the IWF, but is normally initiated by the MS. If the modems synchronise before the RLP has been established, the IWF stores the information received from the other modem in the L2R buffers.

The UE initiates the RLP after the physical connection has been established. When the RLP link has been established, CT107 at the DCE/DTE interface will be changed from "OFF" to "ON". From this time the information from/to the RLP, including status changes, will be mapped by the L2R entity.

### 8.2 Digital services

#### 8.2.1 Transparent case

The procedures are the same as for the modem case, but, depending on implementation, the IWF may through connect before the fixed network leg has been synchronised.

## 8.2.2 Non-Transparent case

The procedures are the same as for the modem case.

## 8.3 Loss of synchronisation

The PLMN side is not synchronous so loss of synchronisation is not possible. For T services, SDUs may be lost or arrive irregularly, which handling is implementation dependent.

Loss of synchronisation on the fixed network side is handled as in GSM.

---

# 9 Call Control

BC-IE negotiation procedures and mapping to ISDN are specified in 3GPP TS 27.001 and 29.007. BC-IE parameter values shall be restricted as indicated in subclause 5.1. See also 3GPP TS 27.001, annex B, table B.5a for further details on the validity of parameter values in GSM.

---

## 10 Handover Issues

### 10.1 Signalling issues

#### 10.1.1 Loss of BC Information during Handover from GSM to UMTS

In the case of inter-MSC handover from GSM to UMTS, the serving GSM MSC/VLR sends a MAP message Prepare Handover carrying the BSSMAP message Handover Request. This message includes the parameter Channel Type, indicating whether radio resources are to be allocated for speech or data (parameter 'Speech or data indicator') and, among other data, the type of data service (transparent/non transparent) and the user rates (both included in the parameter 'Channel rate and type').

As no other bearer capability related parameters are received, it is not possible to distinguish between any other services than 'speech', 'data transparent' and 'data non-transparent'.

The mapping into QoS radio access parameters would be done as described in Section 5.2, limited to the services 'speech', 'data, non-transparent' and 'data, transparent'.

#### 10.1.2 Handover from UMTS to GSM

In case a UMTS call is set up in the CN, the BC IE parameters are mapped into QoS RAB parameters at call setup.

If the CN has to perform a handover towards GSM, the non-anchor MSC needs to perform an assignment based on GSM traffic channel parameters.

In case of handover from UMTS to GSM, the anchor MSC maps the BC IE parameters into GSM traffic channel parameters. This requires that the BC IE is coded according to GSM protocol requirements, i.e. all those parameters ignored in UMTS should nevertheless be correctly specified by the UE in order to perform a handover to GSM.

### 10.2 User Plane

#### 10.2.1 Handover from UMTS to GSM

After a handover from UMTS to GSM the user plane between the anchor MSC and the visited MSC shall comply to the standard GSM A-interface protocols, i.e.:

- A-TRAU or modified V.110 frames as defined in 3GPP TS 04.21 [18] and 3GPP TS 08.20 [19].

- up to four 16kbit/s substreams are multiplexed in one 64kbit/s channel (Split/Combine function and Multiplexing function as defined in 3GPP TS 04.21 [18] and 3GPP TS 08.20 [19]).

## 10.2.2 Handover from GSM to UMTS

After a handover from GSM to UMTS the user plane between the anchor MSC and the visited MSC shall comply to the A-TRAU' protocol except for FNUR = 56 kbit/s (ITC=RDI) and FNUR = 64 kbit/s (ITC=UDI). For both exceptions a plain 64 kbit/s channel is used between the MSCs.

The A-TRAU' protocol is defined as follows:

- A-TRAU' frames are transmitted in regular intervals of 10 ms;
- an A-TRAU' frame consists of two consecutive A-TRAU frames (as defined in 3GPP TS 08.20 [19]) each with a length of 320 bit;
- the A-TRAU' protocol is used on a plain 64 kbit/s channel without substreams;
- the same A-TRAU' format is used for the transparent and non-transparent transmission mode;
- in transparent mode the number of data bits in an A-TRAU' frame depend on the user rate only, each user rate corresponds to a fixed number of data bits (see below);
- in non-transparent mode A-TRAU' frames contain always complete RLP frames, rate adaptation is performed by means of the M2 bit;
- the M1-bit is used to identify 1<sup>st</sup> and 2<sup>nd</sup> frame in both transmission modes.

### 10.2.2.1 Frame layout for the different transparent user rates

The number of data bits in an A-TRAU' frame depend on the user rate only, each user rate corresponds to a fixed number of data bits in an A-TRAU' frame.

Date Rate	Number of data bits per A-TRAU' frame
33,6 kbit/s	336
28,8 kbit/s	288

The data bits are inserted in the A-TRAU' frame starting with D1 of Data field 1 of the first A-TRAU frame. The unused bits are filled with binary '1'.

### 10.2.2.2 A-TRAU' frame format

One A-TRAU' frame consists of two consecutive A-TRAU frames. The following figure shows the format of one A-TRAU frame.



Octet number	bit number								
	0	1	2	3	4	5	6	7	
0	0	0	0	0	0	0	0	0	
1	0	0	0	0	0	0	0	0	
2	1	<b>C1</b>	<b>C2</b>	<b>C3</b>	<b>C4</b>	<b>C5</b>	<b>M1</b>	<b>M2</b>	
3	<b>Z1</b>	D1	D2	D3	D4	D5	D6	D7	36 bit data field 1
4	D8	D9	D10	D11	D12	D13	D14	D15	
5	D16	D17	D18	D19	D20	D21	D22	D23	
6	D24	D25	D26	D27	D28	D29	D30	D31	
7	D32	D33	D34	D35	D36	<b>Z2</b>	D1	D2	36 bit data field 2
8	D3	D4	D5	D6	D7	D8	D9	D10	
9	D11	D12	D13	D14	D15	D16	D17	D18	
10	D19	D20	D21	D22	D23	D24	D25	D26	
11	D27	D28	D29	D30	D31	D32	D33	D34	36 bit data field 3
12	D35	D36	<b>Z3</b>	D1	D2	D3	D4	D5	
13	D6	D7	D8	D9	D10	D11	D12	D13	
14	D14	D15	D16	D17	D18	D19	D20	D21	
15	D22	D23	D24	D25	D26	D27	D28	D29	36 bit data field 4
16	D30	D31	D32	D33	D34	D35	D36	<b>Z4</b>	
17	D1	D2	D3	D4	D5	D6	D7	D8	
18	D9	D10	D11	D12	D13	D14	D15	D16	
19	D17	D18	D19	D20	D21	D22	D23	D24	36 bit data field 5
20	D25	D26	D27	D28	D29	D30	D31	D32	
21	D33	D34	D35	D36	<b>Z5</b>	D1	D2	D3	
22	D4	D5	D6	D7	D8	D9	D10	D11	
23	D12	D13	D14	D15	D16	D17	D18	D19	36 bit data field 6
24	D20	D21	D22	D23	D24	D25	D26	D27	
25	D28	D29	D30	D31	D32	D33	D34	D35	
26	D36	<b>Z6</b>	D1	D2	D3	D4	D5	D6	
27	D7	D8	D9	D10	D11	D12	D13	D14	36 bit data field 7
28	D15	D16	D17	D18	D19	D20	D21	D22	
29	D23	D24	D25	D26	D27	D28	D29	D30	
30	D31	D32	D33	D34	D35	D36	<b>Z7</b>	D1	
31	D2	D3	D4	D5	D6	D7	D8	D9	36 bit data field 8
32	D10	D11	D12	D13	D14	D15	D16	D17	
33	D18	D19	D20	D21	D22	D23	D24	D25	
34	D26	D27	D28	D29	D30	D31	D32	D33	
35	D34	D35	D36	<b>Z8</b>	D1	D2	D3	D4	
36	D5	D6	D7	D8	D9	D10	D11	D12	
37	D13	D14	D15	D16	D17	D18	D19	D20	
38	D21	D22	D23	D24	D25	D26	D27	D28	
39	D29	D30	D31	D32	D33	D34	D35	D36	

Figure 5: A-TRAU 320 bit frame

**Data Bits (Dxx):**

The 288 data bits of an A-TRAU frame are divided in eight fields of 36 bits.

**Control bits (C Bits):**

**C1 to C4:**

The Control bits C1 to C4 define the used data rate. C1 to C4 in the first A-TRAU frame indicate the data rate in send direction.

C1 to C4 in the second A-TRAU frame indicate the used data rate in backward direction. This is required for Rate Control that is required in uplink direction. For details on rate control see 3GPP TS 25.415 [13].

C1	C2	C3	C4	Radio Interface User Rate
1	0	1	1	57,6 kbit/s
1	0	1	0	33,6 kbit/s
1	0	0	0	28,8 kbit/s
0	1	1	1	14,4 kbit/s

**C5:**

C5 is not used, it is set to binary '1'.

**Bit M1:**

An A-TRAU' frame is made of two consecutive A-TRAU which build the transport container for 576 data bits. Bit M1 is used to determine the order of the A-TRAU frames within an A-TRAU' frame.

The two M1 bits are referred to as the Frame Start Identifier. The FSI value is 01. These values are assigned to the M1 bit as shown below:

	M1 bit
First A-TRAU frame	0
Second A-TRAU frame	1

**Bit M2:**

The M2 bit is used to indicate 'valid' A-TRAU' frames. The M2 bit in both of the two consecutive A-TRAU frames relating to an A-TRAU' frame shall have the same value.

Transparent mode:

In transparent mode M2 is clamped to binary '0'.

Non-transparent mode:

In non-transparent mode M2 is used for DTX. If DTX is applied, M2 is set to binary '1'. If DTX is not to be applied, M2 bit is set to binary '0'. The DTX handling is used in both directions for rate adaptation purpose. This means that the sending entity will insert 'fill RLP-frames' with DTX set to binary '1' in case no RLP-frame is available.

Fill frames are also sent in order to adapt the RLP transmission frequency to the AIUR. The ratio between RLP frames and 'fill' RLP frames is defined in the following table:

AIUR	Ratio between RLP and 'fill' RLP frames
57.6 kbit/s	Only valid frames
28.8 kbit/s	1 valid frame followed by 1 'fill' frame
14.4 kbit/s	1 valid frame followed by 3 'fill' frames

**Z bits:**

The bits Zi are used for Framing Pattern Substitution mechanism. This mechanism is defined in 3GPP TS 08.20 [19].

**Mapping of A-TRAU' frames to PCM time slots:**

A-TRAU' frames shall be mapped octet aligned to PCM time slots. I.e. bit number 0 to 7 of each octet of an A-TRAU' frame shall be mapped to bit number 0 to 7 of the PCM time slot.

### 10.2.3 Handover within 3G PLMNs

After a handover from a 3G MSC to another 3G MSC the user plane between the anchor MSC and the visited MSC shall comply to

- the Iu UP protocol if both MSC are connected via an ATM interface.
- the A-TRAU' protocol if both MSC are connected via a TDM interface except for the transparent cases FNUR = 32 kbit/s (ITC = UDI), FNUR = 56 kbit/s (ITC=RDI) and FNUR = 64 kbit/s (ITC=UDI). For these exceptions a plain 64 kbit/s channel is used between the MSCs. The rate adaptation between 64kbit/s and 32kbit/s is based on ITU-T I.460.

## 10.2.4 Handover for 56kbit/s

The FNUR = 56 kbit/s in transparent mode can be supported in GSM by two configurations:

1. without IWF with the following channel codings

- 2\*TCH/F32.0
- 5\*TCH/F9.6

2. with IWF with the following channel coding

- 4\*TCH/F14.4

The FNUR = 56 kbit/s in transparent mode is supported in UMTS by a configuration without IWF only. Therefore handover for 56kbit/s in transparent mode between UMTS and GSM can be supported only for configurations without IWF.

## Annex A: Change history

Change history							
Date	TSG #	TSG Doc.	CR	Rev	Subject/Comment	Old	New
03-2000	TSG#07	NP-000053			Approved to be placed under TSG Change control	2.0.0	3.0.0
06-2000	TSG#08	NP-000223	001		Deletion of T 56 kbit/s for UDI	3.0.0	3.1.0
06-2000	TSG#08	NP-000223	002		Residual bit error ratio in Transparent Data	3.0.0	3.1.0
06-2000	TSG#08	NP-000223	003		Adding the value of GBR of NT services	3.0.0	3.1.0
06-2000	TSG#08	NP-000223	004		Indication of discontinuous transfer for NT data	3.0.0	3.1.0
06-2000	TSG#08	NP-000229	005		Clarification of luUP in Transparent	3.0.0	3.1.0
06-2000	TSG#08	NP-000223	006		Clarification for 56 and 64 kbit/s	3.0.0	3.1.0
06-2000	TSG#08	NP-000223	007		Alignment with 29.007	3.0.0	3.1.0
06-2000	TSG#08	NP-000229	008		Clarification of luUP PDU Type for NT data	3.0.0	3.1.0
09-2000	TSG#09	NP-000543	009		Cleanup of RAB parameter setting	3.1.0	3.2.0
09-2000	TSG#09	NP-000468	011		Transparent 32 kbit/s data rate with I.460 rate adaptation	3.1.0	3.2.0
09-2000	TSG#09	NP-000302	012		Deletion of UMTS NT-RT FAX from R'99	3.1.0	3.2.0
09-2000	TSG#09	NP-000542	014		3.1 kHz multimedia calls at 33.6 kbit/s data rate	3.1.0	3.2.0
09-2000	TSG#09	NP-000543	016		Delivery of erroneous SDUs parameter value	3.1.0	3.2.0
12-2000	TSG#10	NP-000605	018		Handover for 56kbit/s	3.2.0	3.3.0
03-2001	TSG#11	NP-010204	020		A-TRAU' correction	3.3.0	3.4.0
03-2001	TSG#11	NP-010043	022		Correction of service's scope	3.3.0	3.4.0
03-2001	TSG#11	NP-010042	023		RAB- assignment request (RAB parameter)	3.3.0	3.4.0
03-2001	TSG#11	NP-010204	024		A-TRAU' synchronization	3.3.0	3.4.0
06-2001	TSG#12	NP-010255	029		Connection Models for CSD and editorial changes	3.4.0	3.5.0
09-2002	TSG#17	NP-020404	033		Handling of M2 Bit for Handover	3.5.0	3.6.0
09-2002	TSG#17	NP-020404	036		Removal of SDU error ratio for NT services	3.5.0	3.6.0

---

## History

<b>Document history</b>		
V3.0.0	March 2000	Publication
V3.1.0	June 2000	Publication
V3.2.0	September 2000	Publication
V3.3.0	December 2000	Publication
V3.4.0	March 2001	Publication
V3.5.0	June 2001	Publication
V3.6.0	September 2002	Publication