

# ETSI TR 123 908 V3.0.0 (2000-01)

---

*Technical Report*

**Digital cellular telecommunications system (Phase 2+) (GSM);  
Universal Mobile Telecommunications System (UMTS);  
Technical Report on Pre-paging  
(3G TR 23.908 version 3.0.0 Release 1999)**

---



Reference

---

DTR/TSGN-0223908U

Keywords

---

GSM, UMTS

**ETSI**

Postal address

---

F-06921 Sophia Antipolis Cedex - FRANCE

Office address

---

650 Route des Lucioles - Sophia Antipolis  
Valbonne - FRANCE  
Tel.: +33 4 92 94 42 00 Fax: +33 4 93 65 47 16  
Siret N° 348 623 562 00017 - NAF 742 C  
Association à but non lucratif enregistrée à la  
Sous-Préfecture de Grasse (06) N° 7803/88

Internet

---

secretariat@etsi.fr  
Individual copies of this ETSI deliverable  
can be downloaded from  
<http://www.etsi.org>  
If you find errors in the present document, send your  
comment to: editor@etsi.fr

---

**Important notice**

This ETSI deliverable may be made available in more than one electronic version or in print. In any case of existing or perceived difference in contents between such versions, the reference version is the Portable Document Format (PDF). In case of dispute, the reference shall be the printing on ETSI printers of the PDF version kept on a specific network drive within ETSI Secretariat.

---

**Copyright Notification**

No part may be reproduced except as authorized by written permission.  
The copyright and the foregoing restriction extend to reproduction in all media.

© European Telecommunications Standards Institute 2000.  
All rights reserved.

---

## Intellectual Property Rights

IPRs essential or potentially essential to the present document may have been declared to ETSI. The information pertaining to these essential IPRs, if any, is publicly available for **ETSI members and non-members**, and can be found in SR 000 314: *"Intellectual Property Rights (IPRs); Essential, or potentially Essential, IPRs notified to ETSI in respect of ETSI standards"*, which is available from the ETSI Secretariat. Latest updates are available on the ETSI Web server (<http://www.etsi.org/ipr>).

Pursuant to the ETSI IPR Policy, no investigation, including IPR searches, has been carried out by ETSI. No guarantee can be given as to the existence of other IPRs not referenced in SR 000 314 (or the updates on the ETSI Web server) which are, or may be, or may become, essential to the present document.

---

## Foreword

This Technical Report (TR) has been produced by the ETSI 3<sup>rd</sup> Generation Partnership Project (3GPP).

The present document may refer to technical specifications or reports using their 3GPP identities or GSM identities. These should be interpreted as being references to the corresponding ETSI deliverables. The mapping of document identities is as follows:

For 3GPP documents:

3G TS | TR nn.nnn "<title>" (with or without the prefix 3G)

is equivalent to

ETSI TS | TR 1nn nnn "[Digital cellular telecommunications system (Phase 2+) (GSM);] Universal Mobile Telecommunications System; <title>

For GSM document identities of type "GSM xx.yy", e.g. GSM 01.04, the corresponding ETSI document identity may be found in the Cross Reference List on [www.etsi.org/key](http://www.etsi.org/key)

---

# Contents

Foreword .....	4
1 Scope.....	5
2 References.....	5
3 Definitions and Abbreviations .....	5
4 Introduction.....	5
5 Applications of Pre-paging .....	6
5.1 Basic Pre-paging .....	6
5.2 Signalling of terminal capabilities to the GMSC/GGSN in Mobile Terminated Transactions .....	7
5.3 Signalling of current radio environment related capabilities (i.e. GSM, UTRAN coverage area) to the GMSC/GGSN.....	7
5.4 Support of active location information retrieval for the CAMEL Any Time Interrogation (ATI) service .....	8
6 Interaction of Pre-paging with Existing Services .....	8
7 Pre-page Negotiation .....	8
7.1 The VPLMN informs the HLR that it can support Pre-paging.....	8
7.2 HLR and G-MSC Give Permission for Pre-paging.....	8
8 VLR Restoration Procedures .....	9
9 Failure Cases.....	10
9.1 Authentication Failure .....	10
9.2 Loss of Radio Contact.....	11
9.3 The Network Fails to deliver IAM.....	11
10 Drawbacks of Pre-Paging .....	11
10.1 Use of Radio Resource .....	11
10.2 MSRN and Radio Resources in Failure Case .....	12
11 Advantages of Pre-Paging.....	13
11.1 Network Resource Efficiency .....	13
11.2 Advantages of the parallel procedure .....	13
11.3 Early Call Forwarding Cases .....	14
12 Open Issues .....	15
13 Impact of Pre-paging on GSM Release 99 Specifications .....	15
<b>Annex A (informative) : Change history .....</b>	<b>16</b>
History.....	17

---

# Foreword

This Technical Specification has been produced by the 3GPP.

The contents of the present document are subject to continuing work within the TSG and may change following formal TSG approval. If the TSG modify the contents of this TS, it will be re-released by the TSG with an identifying change of release date and an increase in the version number as follows:

Version 3.y.z

where:

- x the first digit:
  - 1 presented to TSG for information;
  - 2 presented to TSG for approval;
  - 3 Indicates TSG approved document under change control.
- y the second digit is incremented for all changes of substance, i.e. technical enhancements, corrections, updates, etc.
- z the third digit is incremented when editorial only changes have been incorporated in the specification;

---

# 1 Scope

The purpose of this Technical Report is to study:

- 1) The potential applications of Pre-paging in GSM/UMTS networks
- 2) The impact of Pre-paging on the GSM/UMTS specifications.
- 3) The interaction of Pre-paging with the work carried out by SMG2 and SMG3 on Classmarks for UMTS (i.e. Service Classmark and Terminal classmark).

It is a requirement of the report that the Pre-paging mechanism must not require an upgrade of the MAP application context version.

---

# 2 References

The following documents contain provisions which, through reference in this text, constitute provisions of the present document.

- References are either specific (identified by date of publication, edition number, version number, etc.) or non-specific.
- For a specific reference, subsequent revisions do not apply.
- For a non-specific reference, the latest version applies.
- A non-specific reference to an ETS shall also be taken to refer to later versions published as an EN with the same number.

[1] GSM 01.04: "Digital cellular telecommunications system (Phase 2+); Abbreviations and acronyms".

---

# 3 Definitions and Abbreviations

UTRAN UMTS Terrestrial Radio Access Network

OR-LCF Optimal Routing - Late Call Forwarding

RNS Radio Network Sub-system

---

# 4 Introduction

In a GSM mobile terminated call, the called mobile station is not paged until after the SRI/PRN procedure is completed. This results in a call path being set up through the GSM network between the GMSC and the VMSC before the mobile station has been paged. In some circumstances this call path may turn out to have been unnecessary if the mobile station does not accept the call (e.g. because the mobile was out of coverage). This represents an inefficient use of network resources.

Pre-paging has been proposed as a means of using network resources in a more efficient manner. In this context, Pre-paging in GSM/UMTS networks refers to the case where the called mobile is paged during the SRI/PRN procedure, i.e. before the MSC/VLR returns the PRN to the GMSC.

Also, this report will study whether Pre-paging is a suitable mechanism to improve the accuracy of location and status information for CAMEL. If so, this could lead to improved services for CAMEL subscribers.

## 5 Applications of Pre-paging

The potential applications of Pre-paging in UMTS are as follows:

1. Basic Pre-paging (i.e. the more efficient use of network resources when mobile terminated calls do not complete)
2. Signalling of terminal capabilities to the GMSC in Mobile Terminated calls
3. Signalling of current radio environment related capabilities (i.e. GSM, UTRAN coverage area) to the GMSC.
4. Support of active location information retrieval for the CAMEL Any Time Interrogation (ATI) service
5. Extension of the scope of Early Call Forwarding on:
  - not reachable (mobile not responding, radio congestion)

Call forwarding on Subscriber Busy will not be studied because the PRN message in MAP version 3 does not support the Subscriber Busy error. It is a requirement that the Pre-paging mechanism must not need an upgrade in the MAP application context version.

### 5.1 Basic Pre-paging

Pre-paging in GSM/UMTS networks refers to the case where the called mobile is paged during the SRI/PRN procedure, i.e. the MSC/VLR returns the PRN to the GMSC after the mobile has responded to the paging message. This is illustrated by **Figure 1**.

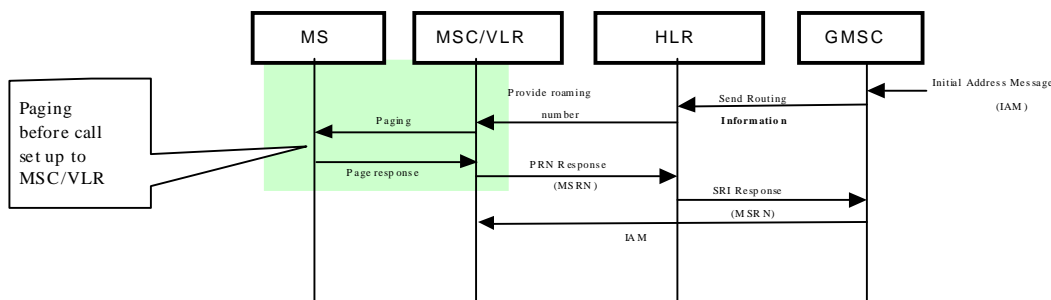

**Figure 1: Basic pre-paging in the UMTS Core Network**

The Pre-paging procedure will need to have the capability to:

- Control when the radio connection in the access network is to be released.
- Define the value of a supervision timer to manage the allocated radio bearer
- Control whether other normal MM/RR procedures (authentication, ciphering) can continue in parallel with incoming call setup after the initial Page Response is received from the MS. This will allow faster incoming call set-ups as access procedures in VMSC are executed in parallel with the core network procedures in GMSC.

The above control information will need to be transferred in the forward direction to the MSC/VLR. Thus the SRI and PRN messages will need to carry additional parameters.

The actual contents of the control parameters sent to the MSC/VLR are for further study.

## 5.2 Signalling of terminal capabilities to the GMSC/GGSN in Mobile Terminated Transactions

The ability to contact the MS for Pre-paging offers opportunities to obtain additional information from the MS in real-time very efficiently as part of generic Pre-paging procedures. This is an example of an enhanced service to CAMEL subscribers. Existing messages will be used where ever possible to “piggy-back” the additional information. The early sending of the MS terminal capabilities will be developed. This will enable decisions to be made in the core network at the earliest opportunity based on the actual status of the MS.

The Pre-paging procedures are likely to be part of the MM procedures (GSM 04.08) which are normally performed in response to Paging from the core network. This will be a one way flow of information of the MS terminal capabilities from the MS towards the core network.

The MS terminal capability information received in the core network (3G MSC/3G SGSN) will be transported transparently to the interrogating node in the core network (3G HLR and subsequently 3G GMSC / 3G GGSN) as part of the existing MAP procedures (GSM 09.02, GSM 03.18)

Thus the MS Terminal Capabilities will be transported to the core network in the following messages:

- Page Response (DTAP signalling)
- PRN Response (MAP signalling)
- SRI Response (MAP signalling)
- Also PSI Response (MAP), ATI Response (MAP) and Initial DP (CAP) will be affected.

The actual contents of the MS Terminal Capabilities fields are for further study. Its relationship to the similar features in GSM will need to be considered – e.g. MS Classmark, MEXE Classmark etc.

The interaction with GSM Location Services (LCS) will need to be considered. It may be possible to also return the information of the actual location of the MS as part of the generic Pre-paging procedures.

## 5.3 Signalling of current radio environment related capabilities (i.e. GSM, UTRAN coverage area) to the GMSC/GGSN.

The ability to contact the MS for Pre-paging offers opportunities to obtain additional information from the serving BSS / RNS in real-time very efficiently as part of general Pre-paging procedures. This is an example of an enhanced service to CAMEL subscribers. Existing messages will be used where ever possible to “piggy-back” the additional information. The early sending of the RNS capabilities will be developed. This will enable decisions to be made in the core network at the earliest opportunity based on the actual status of the serving RNS.

This feature will enable the core network to determine the capability of the access network serving the MS i.e. whether GSM or UMTS coverage serves the MS. This real time information may be useful in the core network when there are functional differences in the access network (for example the location of the Transcoder).

These procedures are likely to be part of the BSSMAP/ RANAP procedures (GSM 08.08) which are normally performed in response to Paging from the core network. This will be a one way flow of information of the serving RNS capabilities from the RNC towards the core network.

The RNS capability information received in the core network (3G MSC/ 3G SGSN) will be transported transparently to the interrogating node in the core network (3G HLR and subsequently 3G GMSC/3G GGSN) as part of the existing MAP procedures (GSM 09.02, GSM 03.18)

Thus the RNS Capabilities will be transported to the core network in the following messages:

- Complete Layer 3 message [Page Response] (BSSMAP/RANAP signalling)
- PRN Response (MAP signalling)
- SRI Response (MAP signalling)
- Also PSI Response (MAP), ATI Response (MAP) and Initial DP (CAP) will be affected.



The actual contents of the RNS Capabilities field are for further study. Its relationship to the similar features in GSM will need to be considered – e.g. MS Classmark, Network Node Capability (e.g. MSC capability) etc.

The interaction with GSM Location Services (LCS) will need to be considered. It may be possible to also return the information of the actual location of the MS as part of the generic Pre-paging procedures.

## 5.4 Support of active location information retrieval for the CAMEL Any Time Interrogation (ATI) service

*[Editor's note: this application will be described in detail within this sub-section.]*

This is an example of an enhanced service to CAMEL subscribers.

---

## 6 Interaction of Pre-paging with Existing Services

Early call forwarding can be extended by Pre-paging to achieve a similar service to OR-LCF on not reachable. However, Pre-paging cannot replace OR-LCF on no reply. More information is given in section 11.3.

Pre-paging has no interaction with Subscriber Busy, since the PRN message in MAP version 3 does not carry the Subscriber Busy error.

No other interactions between Pre-paging and other GSM services have been identified.

---

## 7 Pre-page Negotiation

The supervision timers for SRI and PRN messages are defined as timer value „M“ (i.e. 15-30 seconds). In a typical network paging can take up to about 10 seconds, so the paging supervision timer is generally set to about 15 seconds. This leads to the following conclusions:

If an HLR or a G-MSC uses a supervision timer value for PRN/SRI of 15 seconds, then Pre-paging in the VPLMN might cause the PRN/SRI supervision timers to expire. However, if the PRN/SRI supervision timer value is set to 30 seconds, then Pre-paging is unlikely to cause the supervision timers to expire.

Therefore a mechanism is needed for the VPLMN and HPLMN to negotiate whether Pre-paging should be used in the VPLMN. Two complementary mechanisms are proposed, which will co-exist independently. These mechanisms are:

The VPLMN informs the HLR that it can support Pre-paging if requested.

The HLR and G-MSC give permission to the VPLMN to use Pre-paging if this is the intention.

### 7.1 The VPLMN informs the HLR that it can support Pre-paging

The Update Location message from the VLR back to the HLR can be used to carry back information that the VLR can support Pre-paging on request.

### 7.2 HLR and G-MSC Give Permission for Pre-paging

This mechanism requires that the actual SRI and PRN timer values in the SRI and PRN messages are conveyed to the VLR. The VLR can judge on receiving these actual timer values whether the VLR can perform Pre-Paging.

In this case, the procedures are as follows;

- a) The SRI message should be modified to include a new information element which identifies the actual timer value used in the G-MSC for the SRI message. This new information element would be included after the ellipses in the SRI message.

- b) The PRN message should be modified to include a new information element which identifies the actual timer value used in the G-MSC for the SRI message. This new information element would be included after the ellipses in the PRN message.
- c) The PRN message should be modified to include a new information element which identifies the actual timer value used in the HLR for the PRN message. This new information element would be included after the ellipses in the PRN message.
- d) When the VMSC in the Pre-paging VPLMN receives the modified PRN message, the VMSC makes the following decision:
  - IF the SRI timer and the PRN timer values are both sent, then the VLR uses these timer values to judge whether pre-paging is possible. For example, if the HLR/G-MSC uses short timer values the VPLMN can decide to pre-page on a short paging timer.
  - IF either the SRI timer or the PRN timer values are not sent to the VMSC, then the VMSC is not allowed to use Pre-paging.

If the VPLMN attempts to use Pre-paging but the mobile station does not respond to paging in time, an "Absent Subscriber" error is returned.

## 8 VLR Restoration Procedures

On VLR restoration triggered by a roaming number request, there is no need to change the VLR restoration procedure which started from the RestoreData message. However, the following points are different from the existing procedures when Basic Pre-paging for normal MT call is considered:

Search For MS message is sent at earlier stage in addition to the Page message.

Authentication procedure is executed after PRN ack, if authentication is required

These differences are described in Figure 2

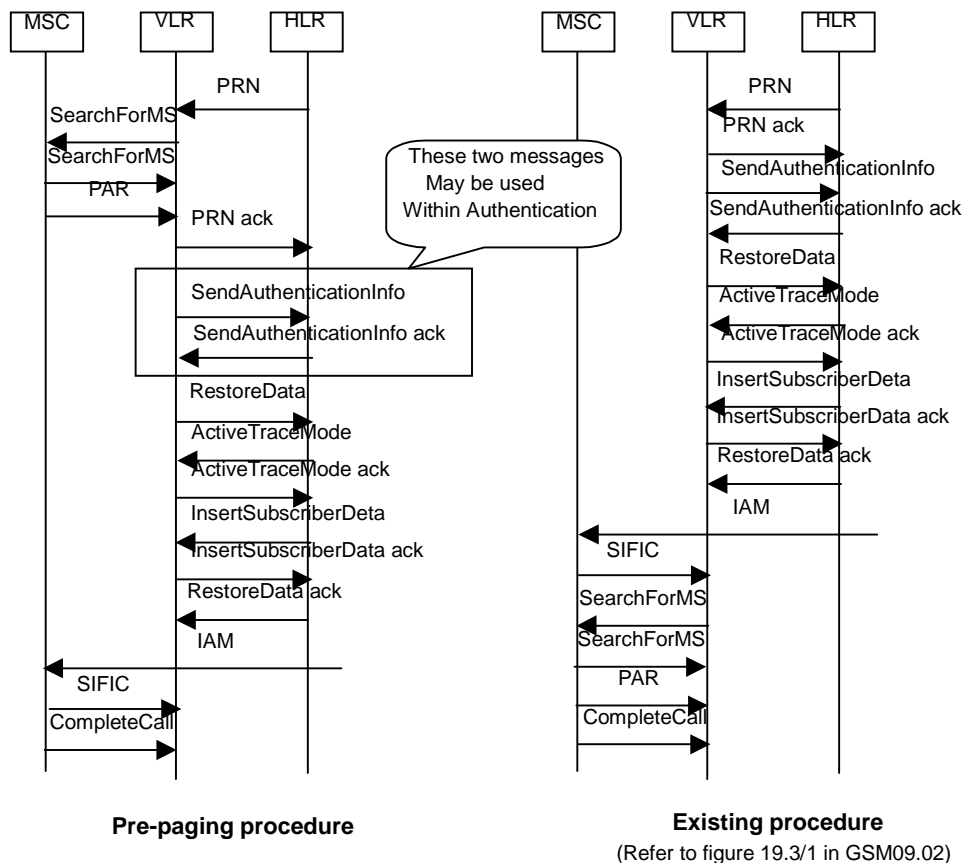

Figure 2 VLR restoration procedures in Pre-paging

## 9 Failure Cases

### 9.1 Authentication Failure

Figure 3 shows two possible cases for authentication failure, i.e where authentication fails before, and then after, SIFIC (Send Information for Incoming Call).

#### Authentication fails before SIFIC

The sequence of events in the case re as follows:

- As soon as authentication fails, the VLR sends the PAR (Process Access Request) negative response message to the MSC.
- When the SIFIC message arrives from the MSC, the VLR sends the SIFIC negative response message.

The PAR negative response message releases the radio resources. The SIFIC negative response message releases the network resources.

#### Authentication fails after SIFIC

The sequence of events in the case re as follows:

- the VLR receives the SIFIC message.
- the VLR waits for the authentication result (i.e. authentication fail)
- The VLR sends the PAR (Process Access Request) negative response message to the MSC.

The PAR negative response message releases the radio resources. The SIFIC negative response message releases the network resources

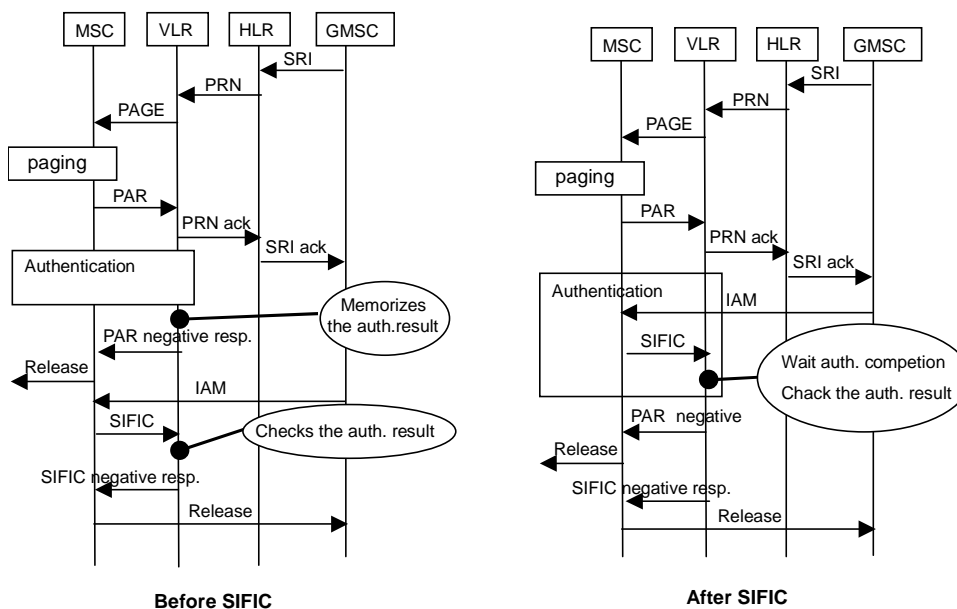

Figure 3 Authentication Failure

## 9.2 Loss of Radio Contact

In the case where the mobile station loses contact with the network before the call completes, the existing GSM radio failure procedures are invoked to release radio and network resources.

There is a possibility that the IAM might be delivered after loss of radio contact. In this case the network will page the mobile station again.

## 9.3 The Network Fails to deliver IAM

Figure 4 shows the case where the IAM is not delivered to the VMSC after the mobile has responded to paging, as follows:

- When the VLR returns a roaming number, the MSC starts the MSRN supervision timer. In non-failure cases, this timer is stopped when the MSC receives the IAM. This MSRN supervision timer is already defined in the GSM specifications.
- If the MSC does not receive IAM, then the MSRN supervision timer expires and the MSC starts the release procedure for radio resources and the MSRN. Note that in the current GSM specifications, expiry of the MSRN supervision timer only leads to the release of the MSRN.

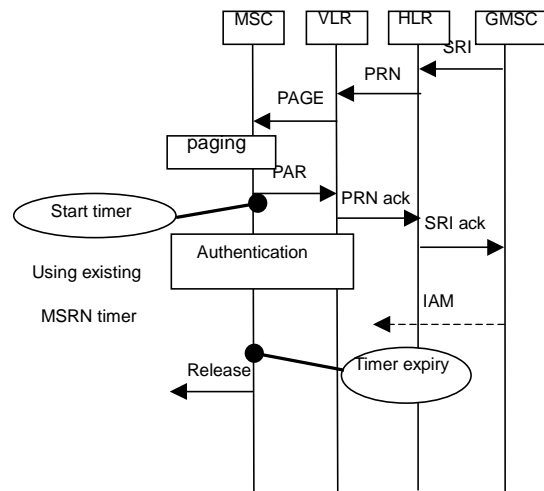

Figure 4 Failure to deliver IAM

## 10 Drawbacks of Pre-Paging

This section identifies and describes the drawbacks of Pre-Paging for the UMTS Core Network.

### 10.1 Use of Radio Resource

Pre-paging is executed during the routing information query procedure, that is, before receiving IAM from the GMSC in the visited network. A major benefit of Pre-Paging is that the call path between HPLMN and VPLMN is not set up in the case where a mobile terminal can not receive a call (e.g. the case of "not reachable").

Pre-paging requires that paging of the mobile terminal is executed at an earlier stage than currently is used in GSM. Therefore, the delay between executing paging and sending SETUP to the mobile terminal becomes a little longer for a Pre-Paging network than an existing GSM network. However, the total time to set up a mobile terminated call is (at worst) unchanged (see Figure 5). In fact the time to set up a call may even be reduced if the routing procedure is executed in parallel with the authentication and encryption procedure.

From the RAN (Radio Access Network) point of view, the paging procedure results in the RAN allocating resources to handle signalling between the mobile terminal and the network. The effect of Pre-Paging in the RAN is that these

resources are allocated a little earlier than is needed compared to a non Pre-Paging RAN. The scale of this inefficiency might be dependent on the type of RAN used, e.g. whether the RAN is GSM or UTRAN.

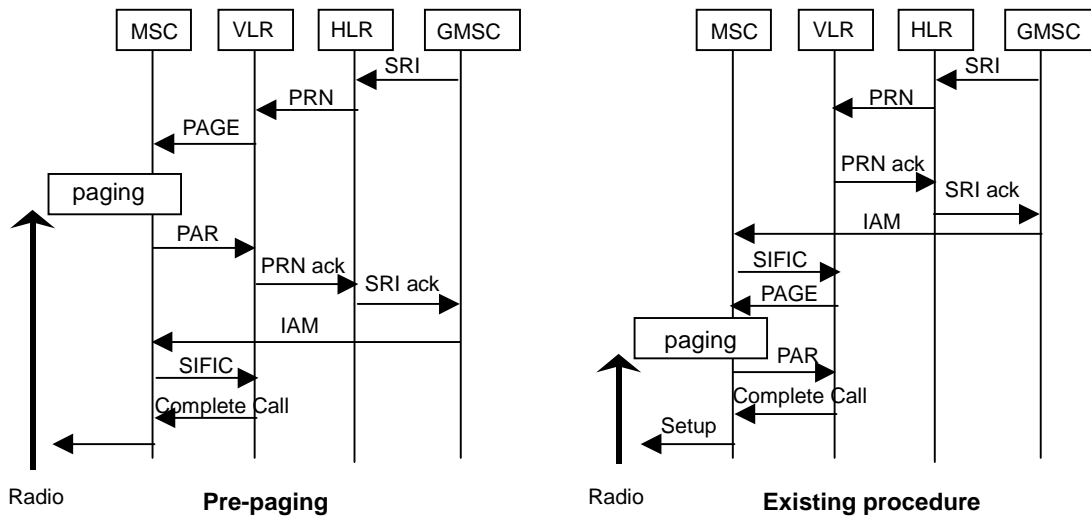

Figure 5: Normal procedure for MT call

## 10.2 MSRN and Radio Resources in Failure Case

In GSM there is a risk that an MSRN is allocated at the VLR without being used. This happens when a mobile terminated call is released at the GMSC by the calling subscriber within the time window which starts with the SRI being sent and ends with the SRI ack being returned

With the introduction of Pre-paging this time window becomes longer and therefore the probability of allocating unused MSRN's increases. Furthermore it is not only the MSRN, but also radio resources which could be allocated without being used. The period for which these resources would be unused could be as much as 90 seconds (i.e. the maximum value of the MSRN supervision timer).

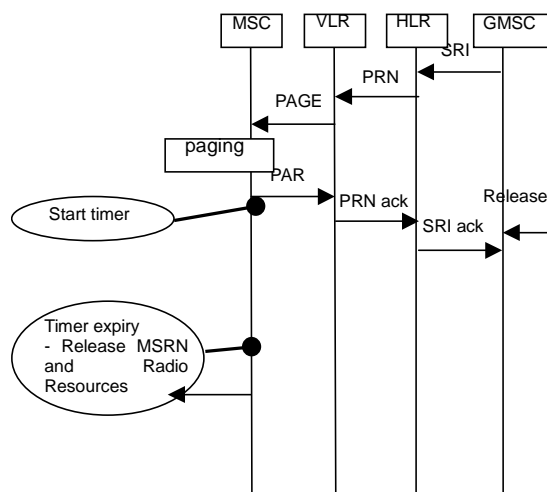

Figure 6 Unused MSRN and Radio Resources

# 11 Advantages of Pre-Paging

## 11.1 Network Resource Efficiency

Pre-paging is executed during the routing information query procedure, that is, before receiving IAM from the GMSC in the visited network. A major benefit of Pre-Paging is that the call path between HPLMN and VPLMN is not set up in the case where a mobile terminal can not receive a call (e.g. the case of “not reachable”).

This can be seen in Figure 7, which illustrates the case where the mobile terminal is not reachable. The savings are: the IAM message from GMSC to visited MSC is not sent if the mobile terminal is not reachable.

The visited MSC does not send the Send\_Info\_For\_Incoming Call message

Therefore the effect of Pre-Paging in the core network is to save resources (i.e. in the GMSC, VMSC, VLR and on inter-network signalling links) in the case where the mobile terminal is not reachable.

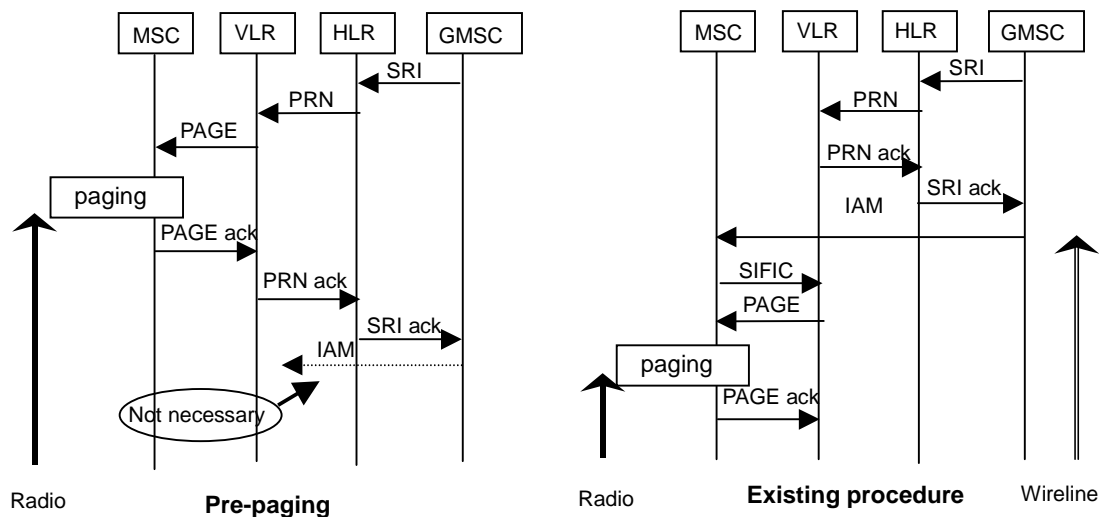
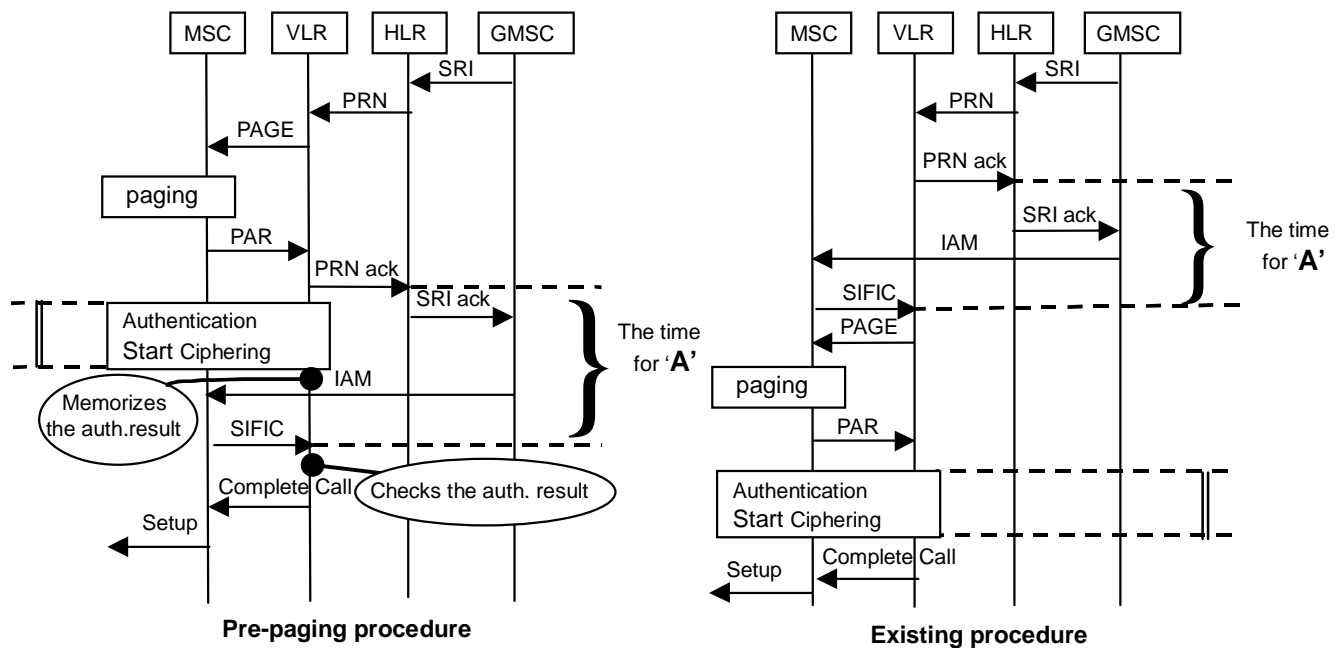

Figure 7: MT call on Not Reachable

## 11.2 Advantages of the parallel procedure

The total time to set up a mobile terminated call is shorter for a pre-paging network than it is for an equivalent non-pre-paging network. This is because the authentication procedure and start ciphering would take place in parallel with the incoming call setup after the Page Response is received from the MS (see Figure 8 ).



**Figure 8: The parallel procedure in Pre-paging**

The rough reduction time within the total time to set up a mobile terminated call is as follows;

The time interval „A“ is defined as the delay between the VLR sending PRN to the HLR, and the VLR receiving the SIFIC message from the VMSC. See Figure 8.

**For the case where the time for Authentication/Start ciphering  $\leq$  the time for ‘A’**

Then call setup time is reduced by the time for Authentication/Start ciphering, because the authentication procedure is executed in parallel with „A“. In this case, the VLR waits for the SIFIC message from the MSC before the VLR sends the complete call message. See Figure 8

**For the case where the time for Authentication/Start ciphering  $>$  the time for ‘A’**

Then call setup time is reduced by the time for „A“, because the authentication procedure is executed in parallel with „A“. In this case, VLR waits for the completion of authentication before the VLR sends complete call message.

The effect of Pre-Paging is that the radio resources are made use of a little longer than for a non Pre-Paging network (see section 10.1). However, because authentication and start ciphering are executed during this extra delay (and in parallel with the routing procedure „A“ mentioned above), then this extra delay is made use of.

## 11.3 Early Call Forwarding Cases

In a Pre-paging network, the SRI message is not returned to the G-MSC until after the called mobile has responded to the page request from the network. It is possible to modify the MAP messages such that the following information can be returned to the HLR and G-MSC in the PRN and SRI messages:

Not reachable (mobile not responding, radio congestion)

On the basis of this information the call can be forwarded by the HLR and G-MSC to another VPLMN, without including a call leg to the original called VPLMN. This shows that early call forwarding can be extended by Pre-paging to achieve a similar service to OR-LCF (on not reachable).

However, Pre-paging does not replace OR-LCF (Call Forwarding on no Reply), i.e. the case where the called mobile responds to paging but the subscriber does not reply. This is because the call path has to be set-up to the original called mobile before the decision to forward the call can be made.

---

## 12 Open Issues

No open issues remain for basic Pre-paging as described in section 5.1.

This report has also proposed further applications beyond basic Pre-paging (see sections 5.2, 5.3 and 5.4). However, it seems likely that the mechanisms to support these further applications will require an upgrade in the MAP application context version. Therefore these further applications have not been studied in detail.

---

## 13 Impact of Pre-paging on GSM Release 99 Specifications

Existing specifications are likely to be affected by Pre-paging work item. Enhancements to the following specifications may be necessary:

- 3G 23.018
- 3G 23.078
- 3G 24.008
- 3G209.002



---

## Annex A (informative) :

### Change history

Change history					
TSG CN#	Spec	Version	CR	New version	Subject/Comment
04	TR 23.908	1.0.0		3.0.0	Version 3.0.0 created, under CN Change Control

---

# History

<b>Document history</b>		
V3.0.0	January 2000	Publication