

Environmental Engineering (EE); The use of alternative energy solutions in telecommunications installations



Reference

DTR/EE-00004

Keywords

power supply

ETSI

650 Route des Lucioles
F-06921 Sophia Antipolis Cedex - FRANCE

Tel.: +33 4 92 94 42 00 Fax: +33 4 93 65 47 16

Siret N° 348 623 562 00017 - NAF 742 C
Association à but non lucratif enregistrée à la
Sous-Préfecture de Grasse (06) N° 7803/88

Important notice

Individual copies of the present document can be downloaded from:

<http://www.etsi.org>

The present document may be made available in more than one electronic version or in print. In any case of existing or perceived difference in contents between such versions, the reference version is the Portable Document Format (PDF). In case of dispute, the reference shall be the printing on ETSI printers of the PDF version kept on a specific network drive within ETSI Secretariat.

Users of the present document should be aware that the document may be subject to revision or change of status. Information on the current status of this and other ETSI documents is available at

<http://portal.etsi.org/tb/status/status.asp>

If you find errors in the present document, please send your comment to one of the following services:

http://portal.etsi.org/chaicor/ETSI_support.asp

Copyright Notification

No part may be reproduced except as authorized by written permission.
The copyright and the foregoing restriction extend to reproduction in all media.

© European Telecommunications Standards Institute 2009.
All rights reserved.

DECT™, **PLUGTESTS™**, **UMTS™**, **TIPHON™**, the TIPHON logo and the ETSI logo are Trade Marks of ETSI registered for the benefit of its Members.

3GPP™ is a Trade Mark of ETSI registered for the benefit of its Members and of the 3GPP Organizational Partners.

LTE™ is a Trade Mark of ETSI currently being registered

for the benefit of its Members and of the 3GPP Organizational Partners.

GSM® and the GSM logo are Trade Marks registered and owned by the GSM Association.

Contents

Intellectual Property Rights	5
Foreword.....	5
Introduction	5
1 Scope	6
2 References	6
2.1 Normative references	7
2.2 Informative references.....	7
3 Definitions, symbols and abbreviations	8
3.1 Definitions	8
3.2 Symbols.....	11
3.3 Abbreviations	11
4 Generator technologies.....	11
4.1 Fuel cells	12
4.1.1 Sources of Hydrogen	12
4.1.2 On site H ₂ production.....	13
4.1.3 Hydrogen storage.....	13
4.1.4 Hydrogen safety.....	14
4.2 Photovoltaic generators	14
4.2.1 Traditional photovoltaic flat module for telecommunications applications.....	14
4.2.2 Short term evolution of solar modules.....	15
4.3 Wind Turbine Generators.....	16
4.3.1 Wind Resource.....	16
4.3.2 The Mechanics of Wind Turbines.....	17
4.4 Micro hydro generators	18
4.5 The Stirling machine	19
5 Energy storage and short term power backup	22
5.1 Batteries.....	24
5.1.1 Lead-acid batteries.....	27
5.1.2 Nickel-Cadmium batteries	28
5.1.3 Nickel-Metal Hydride batteries (Ni-MH)	29
5.1.4 Nickel-Iron batteries (Ni-Fe)	29
5.1.5 Nickel-Zinc batteries (Ni-Zn)	29
5.1.6 Lithium Ion batteries (Li-Ion).....	29
5.1.7 Lithium Ion Polymer batteries (LiP-Ion)	30
5.1.8 Lithium Metal Polymer batteries (LMP)	30
5.1.9 Sodium sulphur (Na-S)	30
5.1.10 Sodium-metal-chloride	30
5.2 Supercapacitors	30
5.3 Fly wheels	31
5.4 Super Magnetic Storage Systems (SMES)	32
5.5 Pumped hydrostorage and compressed air	32
5.6 Reliability of energy storage systems	32
5.7 Safety of energy storage systems	32
6 Power Systems	33
6.1 Fuel cell systems	33
6.2 Photovoltaic systems	35
6.2.1 Off-grid connection system.....	35
6.2.2 In-grid connection system.....	36
6.2.3. Planning of a PV system.....	38
6.3 Wind energy systems.....	38
6.3.1 System design	39
6.3.2 Installation	40

6.4	Hydropower systems	40
7	Hybrid systems	41
7.1	System design.....	41
7.2	Planning of a Hybrid system	43
7.3	Selected Hybrid systems	44
7.3.1	Wind turbine generator combined with fuel consuming generator.....	44
7.3.2	Photovoltaic generator combined with fuel consuming generator.....	45
7.3.3	Photovoltaic generator combined with wind generator and fuel consuming generator	47
8	Cooling systems	48
8.1	Geo-cooling	48
8.1.1	Horizontal collectors.....	51
8.1.2	Vertical probes.....	52
8.1.3	Ground-to-air heat exchanger	52
8.2	Free cooling.....	53
8.3	Absorption machines	56
Annex A:	Bibliography	57
	History	58

Intellectual Property Rights

IPRs essential or potentially essential to the present document may have been declared to ETSI. The information pertaining to these essential IPRs, if any, is publicly available for **ETSI members and non-members**, and can be found in ETSI SR 000 314: "*Intellectual Property Rights (IPRs); Essential, or potentially Essential, IPRs notified to ETSI in respect of ETSI standards*", which is available from the ETSI Secretariat. Latest updates are available on the ETSI Web server (<http://webapp.etsi.org/IPR/home.asp>).

Pursuant to the ETSI IPR Policy, no investigation, including IPR searches, has been carried out by ETSI. No guarantee can be given as to the existence of other IPRs not referenced in ETSI SR 000 314 (or the updates on the ETSI Web server) which are, or may be, or may become, essential to the present document.

Foreword

This Technical Report (TR) has been produced by ETSI Technical Committee Environmental Engineering (EE).

Introduction

In last year's thematic, as greenhouse effect and carbon footprint have been more common and well known also to normal citizen; a lot of attention has been also pointed to the telecommunication community impact. The growing public attention to environmental issues leads industry to work on reducing environmental impacts of their business, also in a framework of Corporate Social Responsibility (CSR) and sustainable development.

High prices for oil and electrical energy, which are generally expected to persist, contribute to stimulate interest in new energy sources.

In telecommunication the alternative energy sources, because of the high cost for Wh, are generally used in remote areas where the public mains is unavailable.

The introduction of new components and technologies on the market has recently increased the energy efficiency of alternative sources and in some cases, the Governments economically support the use of this alternative energy sources.

The consequence of those two facts is a better convenience in the use of this type of energy, especially considering the continuous price increase for traditional fossil sources and electrical energy, beyond the attention that is necessary for reducing ecological impacts.

The need for alternative energy may come also to enable telecommunication services (areas with no power grid), to expand coverage and to deploy high data rate services (active equipment in the access network)

It becomes obvious that the use of alternative energy has to be considered with particular effort for only supplying energy efficient ICT equipment.

One important bibliographical reference is the international document produced by ITU-T (CCITT), in 1985 [i.1]

1 Scope

Due to new power and energy context such as greenhouse effect and other environmental issues, fuel depletion and electricity cost increase, new regulation and standards, telecom operators have to make efforts to use alternatives. The present document covers alternative energy sources completed by current and new energy storage that can be used in ICT. Such alternative energy sources are:

- Fuel Cells.
- Photovoltaic Generators.
- Wind Turbine Generators.
- Micro hydro generators.
- Stirling machine.
- Alternative cooling sources, e.g. geo-cooling, fresh air cooling (or free cooling), absorption machines.

The scope of the present document is to propose an overview about practical solutions for power and cooling systems using the alternative energy sources. Interoperability of heterogeneous alternative energy sources is the key issue. The way to ensure hybrid systems reliability and efficiency is also in the scope of the present document.

Bearing in mind the availability and the maintainability of the power plants for TLC, the present document considers:

- the principle of energy converters operating from alternative energy sources;
- the minimum set of information on energy converters;
- the main sizing parameters;
- the architecture of the power systems using the energy converters either only one type or as a combination of two or more such devices;
- existing and new energy storage;
- cooling solutions from alternative sources (geo-cooling).

New (not traditional) solutions for cooling will be proposed and expanded in a separate document.

2 References

References are either specific (identified by date of publication and/or edition number or version number) or non-specific.

- For a specific reference, subsequent revisions do not apply.
- Non-specific reference may be made only to a complete document or a part thereof and only in the following cases:
 - if it is accepted that it will be possible to use all future changes of the referenced document for the purposes of the referring document;
 - for informative references.

Referenced documents which are not found to be publicly available in the expected location might be found at <http://docbox.etsi.org/Reference>.

NOTE: While any hyperlinks included in this clause were valid at the time of publication ETSI cannot guarantee their long term validity.

2.1 Normative references

The following referenced documents are indispensable for the application of the present document. For dated references, only the edition cited applies. For non-specific references, the latest edition of the referenced document (including any amendments) applies.

Not applicable.

2.2 Informative references

The following referenced documents are not essential to the use of the present document but they assist the user with regard to a particular subject area. For non-specific references, the latest version of the referenced document (including any amendments) applies.

- [i.1] ITU-T (CCITT): "Handbook on Primary Sources of Energy for the Power Supply of Remote Telecommunication Systems", 1985.
- [i.2] CENELEC EN 62282-2: "Fuel cell technologies. Part 2: Fuel cell modules".
- [i.3] CENELEC EN 62282-3-2: "Fuel cell technologies - Part 3-2: Stationary fuel cell power systems - Performance test methods".
- [i.4] Council Directive 87/404/EEC of 25 June 1987 on the harmonization of the laws of the Member States relating to simple pressure vessels.
- [i.5] Council Directive 90/488/EEC of 17 September 1990 amending Directive 87/404/EEC on the harmonization of the laws of the Member States relating to simple pressure vessels.
- [i.6] Council Directive 90/396/EEC of 29 June 1990 on the approximation of the laws of the Member States relating to appliances burning gaseous fuels.
- [i.7] Council directive 1999/92/EC of 25 January 1999 on minimum requirements for improving the safety and health protection of workers potentially at risk from explosive atmospheres.
- [i.8] Council directive 94/9/EC of 23 March 1994 on the approximation of the laws of the Member States concerning equipment and protective systems intended for use in potentially explosive atmospheres.
- [i.9] Council directive 97/23/EC of 29 May 1997 on the approximation of the laws of the Member States concerning pressure equipment.
- [i.10] CENELEC EN 62124: "Photovoltaic (PV) stand-alone systems. Design verification".
- [i.11] CENELEC EN 60904-1: "Photovoltaic Devices Part 1: Measurement of Photovoltaic Current - Voltage Characteristics".
- [i.12] CENELEC EN 60904-2: "Photovoltaic devices - part 2: requirements for reference solar devices".
- [i.13] CENELEC EN 62093: "Balance-of-system components for photovoltaic systems - Design qualification natural environments".
- [i.14] Council directive 2006/66/EC of the European parliament and of the council of 6 September 2006 on batteries and accumulators and waste batteries and accumulators and repealing Directive 91/157/EEC.
- [i.15] CENELEC EN 50272-2: "Safety requirements for secondary batteries and battery installations -- Part 2: Stationary batteries".
- [i.16] ETSI ETS 300 132-1: "Equipment Engineering (EE); Power supply interface at the input to telecommunications equipment; Part 1: Operated by alternating current (ac) derived from direct current (dc) sources".
- [i.17] ETSI EN 300 132-2: "Environmental Engineering (EE); Power supply interface at the input to telecommunications equipment; Part 2: Operated by direct current (dc)".

- [i.18] CENELEC EN 61427: "Secondary cells and batteries for solar photovoltaic energy systems".
- [i.19] IEC 61400-1: "Wind turbines - Part 1: Design requirements".

3 Definitions, symbols and abbreviations

3.1 Definitions

For the purposes of the present document, the following terms and definitions apply:

Air Mass (AM): measure of distance that the direct solar beam travels through the earth atmosphere

NOTE: AM = 1,5 in standards corresponds to a sun elevation of approximately 45°.

air pollution: air with contaminants in it that prevent the air from dispersing as it normally would, and interfere with biological processes

alternative energy: energy derived from non-fossil resource and from renewable source

NOTE: A popular term for "non-conventional" or "clean" energy as renewable.

asynchronous generator: type of electric generator that produces alternating current (AC) electricity to match an existing power source

battery: energy storage device made up of one or more cells filled with electrolyte

NOTE: An electrolyte is a non-metallic conductor between positive and negative plates that carries electric charges through ionic displacement.

capacity factor: amount of power a wind turbine produces over a period of time divided by the amount of power it could have produced if it had run at its full rated capacity over that time period

Carbon Dioxide (CO₂): colourless, odourless non-combustible gas present in the atmosphere

NOTE: It is formed by the combustion of carbon and carbon compounds (such as fossil fuels and biomass), by respiration, which is a slow combustion in animals and plants, and by the gradual oxidation of organic matter in the soil. It is a greenhouse gas that contributes to global climate change, it remains in the atmosphere during about one century.

Carbon Monoxide (CO): colourless, odourless but poisonous combustible gas

NOTE: Carbon monoxide is produced in the incomplete combustion of carbon and carbon compounds, for example, fossil fuels like coal and petroleum.

central power plant: large power plant that generates power for distribution to one or multiple loads

chemical energy: energy liberated in a chemical reaction, as in the combustion of fuels

constant-speed wind turbines: wind turbines that operate at a constant RPM (Revolutions Per Minute speed). They are designed for optimal energy capture at a specific rotor diameter and at a particular wind speed

conventional fuel: fossil fuels: coal, oil, and natural gas

electric power converter: device for transforming electricity to a desired quality and quantity (voltage or current or power or frequency)

energy converter: equipment transforming alternative energy sources (solar, wind, hydro, etc.) into electrical energy

deregulation: process of changing policies and laws of regulation in order to increase competition among suppliers of commodities and services

downwind wind turbine: horizontal axis wind turbine in which the rotor is downwind of the tower

emission: substance or pollutant emitted as a result of a process

energy storage: process of storing or converting energy from one form to another for later use

NOTE: For example, an electrochemical storage device is a battery, an electromechanical storage device is a flywheel.

environment: all the natural and living things around us: The earth, air, weather, plants, human and animals all make up our environment

fossil fuels: fuels formed in the ground from the decayed remains of dead plants and animals

NOTE: It takes millions of years to form fossil fuels. Oil, natural gas, and coal are fossil fuels.

fuel: any material that can be consumed to be converted into energy

gearbox: protective casing for a system of gears

generator: device for converting any energy resource into electrical energy

geothermal: heat that comes from within the Earth

geothermal heating/cooling: method of heating and cooling a building using underground thermal conditions

geothermal power: electricity generated from naturally occurring geological heat sources

green credit: new way to purchase renewable electric generation that divides the generation into two separate products: the commodity energy and the renewable attributes

NOTE: The green credit represents the renewable attributes of a single megawatt of renewable energy. Also known as green tags, renewable energy credits, or renewable energy certificates.

green power: popular term for energy produced from non-pollutant or renewable energy resources

greenfield: site on which a power plant has not previously existed

grid: common term referring to an electricity transmission and distribution system

gust: sudden brief increase in the speed of the wind

horizontal-axis wind turbines: turbines on which the axis of the rotor's rotation is parallel to the wind stream and the ground

hybrid system: power systems combining two or more energy conversion devices, or two or more fuels for the same device, that when integrated, overcome limitations inherent in either

NOTE: In the present document we define that at least one source is from alternative "renewable" energy source.

inverter: equipment that can convert direct current into alternative current

mean power output (of a wind turbine): average power output of a wind energy conversion system at any given mean wind speed

mean wind speed: average wind speed over a specified time period and height above the ground

mechanical energy: energy possessed by an object due to its motion (kinetic energy) or its potential energy

median wind speed: wind speed with 50 % probability of occurring

nacelle: cover for the gearbox, drive train, and generator of a wind turbine

natural gas: hydrocarbon gas obtained from underground sources, often in association with petroleum and coal deposits

NOTE: It generally contains a high percentage of methane, varying amounts of ethane, and inert gases. Natural gas is used as a heating fuel and for electricity generation.

peak wind speed: maximum instantaneous wind speed that occurs within a specific period of time

photovoltaic: application of solar cells for energy by converting sunlight directly into electricity

power quality: stability of frequency and voltage and lack of electrical noise on the power grid

prevailing wind direction: direction from which the wind predominantly blows as a result of the seasons, high and low pressure zones, the tilt of the earth on its axis, and the rotation of the earth

recycling: process of converting into new products materials that are no longer useful as they were originally designed

renewable energy: energy derived from resources that are regenerative or that cannot be depleted

NOTE: Types of renewable energy resources include wind, solar, biomass, geothermal and moving water.

rotor: blades and other rotating components of a system (e.g. rotor of a wind energy conversion turbine in the alternative energy sources field)

solar energy: electromagnetic energy transmitted from the sun (solar radiation)

solid fuels: any fuel that is in solid form, such as wood, peat, lignite, coal, and manufactured fuels such as pulverized coal, coke, charcoal briquettes, and pellets

step-up gearbox: gearbox that increases turbine electricity production in stages by increasing the number of generator revolutions produced by the rotor revolutions

sustainable energy: energy that takes into account present needs while not compromising the availability of energy or a healthy environment in the future

trade wind: consistent system of prevailing winds occupying most of the tropics

NOTE: They constitute the major component of the general circulation of the atmosphere. Trade winds blow northeasterly in the Northern Hemisphere and southeasterly in the Southern Hemisphere. The trades, as they are sometimes called, are the most persistent wind system on earth.

turbine: term used for a wind energy conversion device that produces electricity

NOTE: see also "Wind Turbine".

turbulence: swirling motion of the atmosphere that interrupts the flow of wind

variable-speed wind turbines: turbines in which the rotor speed increases and decreases with changing wind speeds

NOTE: Sophisticated power control systems are required on variable speed turbines to insure that their power maintains a constant frequency compatible with the grid.

vertical axis wind turbines: turbines on which the axis of the rotor's rotation is perpendicular to the ground

Watt-peak (Wp): unit used to express the maximum power produced (or provided) by a photovoltaic module for solar radiation of 1 000 W/m² for a standard spectrum and temperature

wind energy: power generated by converting the mechanical energy of the wind into electrical energy through the use of a wind generator

wind farm: piece of land on which wind turbines are sited for the purpose of electricity generation

wind (turbine) generator: system that converts kinetic energy in the wind into electrical energy

NOTE: See IEC 61400-1 [i.19].

wind power plant: group of wind turbines interconnected to a common utility system

wind resource assessment: process of characterizing the wind resource and its energy potential for a specific site or geographical area

wind speed: rate of flow of wind when it blows undisturbed by obstacles

NOTE: Expressed in m/s.

wind speed frequency curve: curve that indicates the number of hours per year that specific wind speeds occur

wind speed profile: profile of wind speed changes at different heights above the surface of the ground or water

wind turbine: wind energy conversion device that produces electricity

wind turbine rated capacity: power that a wind turbine can produce at its rated wind speed

wind velocity: wind speed and direction in an undisturbed flow

3.2 Symbols

For the purposes of the present document, the following symbols apply:

Wh	watt-hours
Wp	watt peak

3.3 Abbreviations

For the purposes of the present document, the following abbreviations apply:

AC	Alternating Current
AFC	Alkaline Fuel Cell
AM	Air Mass
BB	BroadBand
BMS	Battery Management System
CPV	Concentrating PhotoVoltaic
DC	Direct Current
DMFC	Direct Methanol Fuel Cell
EV	Electrical Vehicle
FC	Fuel Cell
GaAs	Gallium Arsenide
HYP	HYdro-Power
LA	Lead Acid
LVBD	Low Voltage Battery Disconnecter
MCFC	Molten Carbonate Fuel Cell
MPPT	Maximum Power Point Tracker
MTBF	Mean Time Between Failure
MTTR	Mean Time To Repair
PAFC	Phosphoric Acid Fuel Cell
PCM	Phase Change Material
PEM	Proton Exchange Membrane
PEMFC	Proton Exchange Membrane Fuel Cell
PTFE	PolyTetraFluoroEthylene
PV	Photovoltaic
PVG	Photovoltaic Generator
RPM	Round Per Minute
SC	Super Capacitor
SMES	Super Magnetic Energy Systems
SoC	State of Charge
SOFC	Solid Oxide Fuel Cell
TLC	Telecommunication
VRLA	Valve Regulated Lead Acid
WTG	Wind Turbine Generator

4 Generator technologies

This part of the present document describes the alternative energy generation technologies that can be considered as a power source for telecommunication applications.

4.1 Fuel cells

A fuel cell is an electrochemical reactor used to convert the chemical energy (reduction and oxidation) contained in an external fuel into electrical energy (Direct Current output power) characterized by a continuous supply of reactants and flowing out of reaction products. The fuel cell can operate without interruptions as long as the necessary flows are maintained.

The fuel cell reactor is composed of sets of positive and negative electrodes, an electrolyte between them (e.g. salt diluted in water or polymer) and a separator (e.g. PEM) to avoid leakage or cross-over of fuel (e.g. H² or methanol) directly towards the oxidizing agent (e.g. air) without producing useful electrons in external circuit.

Elementary fuel cell voltage are very low (0,1 V to 1 V in open circuit) and several cells are mounted in serial arrangement (stack) to obtain practical voltage for powering telecom equipment. The current is dependant of the plate surface.

There are various types of fuel cells available as showed in the following table.

Table 1: Types of Fuel Cells

FC type	PEMFC	AFC	DMFC	PAFC	MCFC	SOFC
Name	Proton Exchange Membrane Fuel Cell	Alkaline Fuel Cell	Direct Methanol Fuel Cell	Phosphoric Acid Fuel Cell	Molten Carbonate Fuel Cell	Solid Oxide Fuel Cell
Electrolyte	Polymer membrane protons conductive	KOH solution	Polymer membrane protons conductive	Phosphoric acid	Molten Li ₂ CO ₃ and K ₂ CO ₃ in LiAlO ₂ matrix	ZrO ₂ and Y ₂ O ₃
Ions in electrolyte	H ⁺	OH ⁻	H ⁺	H ⁺	CO ₃ ²⁻	O ²⁻
Temperature In operation	40 °C to 80 °C	60 °C to 80 °C	60 °C to 100 °C	180 °C to 220 °C	600 °C to 660 °C	700 °C to 1 000 °C
Fuel	H ₂ (pure or from reformer)	H ₂	Methanol	H ₂ (pure or from reformer)	bio-gas and natural gas	bio-gas and natural gas)
Oxidant	Air	O ₂ (pure)	Air	Air	Air	Air
System efficiency	30 % to 50 %	60 %	20 % to 30 %	40 %	45 %	55 % to 60 %
Applications	Transport, Portable equipment, Cogeneration, Back-up	Spatial	Portable equipment	Cogeneration	Cogeneration, Centralized electricity production	Cogeneration, Centralized electricity production Transport
Developing progress	Small series	Used	Small series	Mature technology	Small series	Small series

The most used in TLC applications are the PEM fuel cells based on a polymer electrolyte in the form of a thin, permeable sheet. Efficiency of the commercial systems is greater than 35 %, and operating temperature is about 40 °C to 80 °C. Cells stack outputs generally range from 50 watt to 250 kW. The higher the operating temperature the less degraded on the hydrogen has to be. PEM fuel cells can provide the solid-state backup power solutions.

The electrical characteristics of fuel cells and their performance tests are described in EN 62282-2 [i.2] and EN 62282-3-2 [i.3].

4.1.1 Sources of Hydrogen

PEM fuel cells use hydrogen as a fuel. Hydrogen for fuel cells can be produced in large central locations and delivered in gaseous, liquid or solid (metal hydride) state in tanks, by pipeline, or can be produced at the fuel cell site using an onsite reformer.

Hydrogen high pressure cylinders tanks are typically used in situations where the fuel cell needs to run for a short period of time (approximately 8 hours).

4.1.2 On site H₂ production

Reforming

There are many types of reforming, each with its own strengths and weaknesses. Steam reforming is often selected for projects because of its ability to provide high efficiency use of valuable fuel inputs. Fuel processors have been developed for a variety of common fuels including methanol (a liquid used as windshield washer and many other common products but highly toxic). Extended run fuel cell systems allow supporting back-up requirements of days versus hours by using compact and convenient liquid fuels.

Electrolyser

In some cases it is possible to produce hydrogen directly on site using a photovoltaic system to electrolyze water (reduction of costs may be achieved in combination with wind and/or grid).

In that case, hydrogen has to be stored in hydrogen storage (see clause 4.1.3) for next use. The H² is still converting in electricity through a fuel cell or a motor+alternator.

This is a solution for interseasonal storage. Even with an efficiency of only 25 % of the H² electrolyser + storage + generator. It can be demonstrated an important gain when producing H² with the wasted excess of energy of PV when battery are charged. The major problem is cost and reliability of this very complex solution.

4.1.3 Hydrogen storage

Hydrogen can be stored in many ways: gas, liquid, in solid hydride.

High pressure storage

Commonly H² is compressed in steel or composite tanks and held at pressures up to 70 MPa.

Most backup power fuel cell systems will use compressed hydrogen as a fuel source located near the fuel cell system. The most typical hydrogen cylinder is often referred to as a "T-cylinder B50", it is approximately 152 cm high and 25 cm wide and holds about 8,5 cubic meters of gas. Multiple tanks are connected together as needed. Each tank weighs approximately 70 kg. An array of four to six tanks contains enough hydrogen to operate a typical 5 kW fuel cell for nine hours at full load. Cylinders are typically pressurized to approximately 200 bar, but the pressure is regulated down to low pressure at the hydrogen tank enclosure to ensure maximum safety and code compliance.

Each T-cylinder stores enough hydrogen to deliver approximately 10 kWh of regulated AC or DC electricity from a fuel cell system. Hydrogen is typically stored outdoors, but can also be located indoors in certain building types if the right safety and ventilation procedures are followed. Suppliers can offer outdoor enclosures or can also recommend approved hydrogen storage options for specific applications.

Liquid storage

H² is liquefied at -252 °C. Liquefying is energy intensive, but liquid hydrogen has three times the amount of energy as an equal weight of gasoline.

Hydride solid storage

Hydrogen can also be stored in metal hydrides - granular metal that absorbs hydrogen. These tanks are comparatively heavy.

Similar, but lighter, are carbon nanotubes, and other carbon absorption techniques still in the experimental stage. Hydrogen can also be stored in chemical hydrides by way of chemical bonds. Chemical hydrides typically allow hydrogen to be stored in conventional tanks that only release hydrogen when a certain catalyst is present, making them very safe for transportation.

4.1.4 Hydrogen safety

Like all good fuels, hydrogen contains a lot of energy. Considering applicable European Directives and standards, hydrogen can be handled safely when guidelines for its safe storage, handling and use are observed. Hydrogen's combustion properties imply the same caution required when using any fuel, as well as care to address the properties unique to hydrogen. Some of hydrogen's special properties actually may provide safety benefits compared to gasoline or other fuels. The hydrogen industry makes, distributes, stores and handles hydrogen nationwide and has compiled an exemplary safety record.

Main references:

- Industrial gas:
 - directive 87/404/EEC [i.4] and its amendment 90/488/EEC [i.5];
 - directive 90/396/EC [i.6];
 - directive 1999/92/EC (ATEX) [i.7] and directive 94/9/EC [i.8];
 - directive 97/23/EC [i.9].
- Hydrogen:
 - Local law and regulation on industrial gas and storage.

4.2 Photovoltaic generators

4.2.1 Traditional photovoltaic flat module for telecommunications applications

Photovoltaic (PV) technology permits the transformation of solar energy directly into electric energy. Solar energy to electric energy conversion takes place within solar cells, which can be amorphous, polycrystalline or monocrystalline, according to their structure. In most cases they are made of silicon. In particular a solar cell is a semiconductor device that converts photons from the sun into electricity. This conversion is called the photovoltaic effect, discovered by Bequerel in 1839.

A photovoltaic module is the basic element of each photovoltaic system. It consists of many solar cells, which are electrically connected and placed between glass and tedlar plate, and framed by an (usually) aluminium frame.

According to the solar cell technology it is possible to distinguish between monocrystalline, polycrystalline and thin film amorphous solar modules. Most commercial crystalline modules consist of 36 or 72 cells. The typical crystalline modules power ranges from a few W to up to 300 W/module with a voltage range from 12 V up to more than 100 V DC. The most important module parameters include a short circuit current, an open circuit voltage and a nominal voltage at 1 000 W/m² solar radiation. Module parameters are measured at standard test conditions (STC) - solar radiation 1 000 W/m², air mass (AM) 1,5 and temperature 25 °C. The documents [i.10], [i.11] and [i.12] give more information about photovoltaic module's characteristics.

A number of solar-modules and other components (batteries, charge regulators, inverters etc.) can form large photovoltaic systems.

Advantages and drawbacks

The advantages of PV include:

- Complementarities with other energy sources, both conventional and renewable.
- Flexibility in terms of implementation. PV systems can be integrated into telecommunication sites.
- Low and simple maintenance.
- Production of electricity without greenhouse gas emissions.
- Long operating life (up to 25 years).

Drawbacks include:

- Low efficiency (7 % to 14 %).
- High costs.
- Possibility of vandalism.

A PV system can deliver electrical energy to a specific appliance consumption or for commercial production in case of electric grid connection.

4.2.2 Short term evolution of solar modules

Reducing cost of PV and improving efficiency are the 2 challenges for the next years. About silicon, after using electronic quality waste, a dedicated industrial process will be favourable to cost decrease, more over other thin film technologies using less material will also be in favour of low cost. The table hereafter shows technologies trends for the next years.

Table 2: PV's technologies trends

Technology	Advantages	Drawback	Market availability
Thin layer CiGS $\eta = 14\%$ to 15% CdTe $\eta = 12\%$ to 15%	Low cost and cheaper than silicon, Sun spectra matched semiconductors	efficiency lower than monocrystal silicon, Longtime stability had to be confirmed	In production since end of 2007
III-V semiconductors multi-junction under concentration $\eta = 35\%$ @ 500 sun	Worldwide efficiency record $\eta = 40,7\%$ in lab, $\eta = 35\%$ in production, Thin layers	Need concentration and tracking equipment, More expensive than silicon	In production by the end of 2008

4.2.3 Photovoltaic Concentrators

A promising approach to lower the cost of electricity generated by solar photovoltaic systems is to use lenses or mirrors to focus, or "concentrate", sunlight from a large area onto a small solar cell receiver. This system is suitable for converting direct solar radiation, so its use is not recommended for places with high ratio of diffuse radiation.

Compared to non-concentrating photovoltaic systems, the required area of solar cells is reduced by the concentration ratio, offering a significant lower price for the photovoltaic system for which the solar cell is one of the most expensive components.

There are many parameters which have to be considered in the design of a concentrating photovoltaic (CPV) system, including: the choice of lenses vs. mirrors; line- vs. point-focus; the concentration ratio, for which values of anywhere between 2 and 1 000 or more are used; and the choice of solar cell technology.

The complete system includes concentrator modules, support and tracking structures, a power processing centre, and land. PV concentrator module components include solar cells, an electrically isolating and thermally conducting housing for mounting and interconnecting the cells, and optical concentrators. The solar cells in today's concentrators are predominantly silicon, although gallium arsenide (GaAs) solar cells may be used because of their high-conversion efficiencies. The housing places the solar cells at the focus of the optical concentrator elements and provides means for dissipating excess heat generated in the solar cells. The optical concentrators are generally Fresnel lenses but can also be mirrors.

The modules have to be mounted on a support structure and, during daylight hours, have to face (or "track") the sun using motors, gears and a controller. Tracking the sun is necessary for high concentration (above approximately 10 "suns" or 10x) and increases the amount of energy captured daily, more than compensating for the losses due to inability to convert diffuse radiation. The concentrator module output flows to a power-processing centre that includes hardware to convert power from Direct Current (DC) to Alternating Current (AC), safety devices, and controls to interface properly with the utility grid or other load.

Current state of worldwide concentrator development shows an extensive typology of technologies, specifically:

- 1-axis-tracking parabolic trough at 50x: a polar-axis tracking reflective trough with 50x concentration on a silicon photovoltaic receiver;
- static (non-tracking) concentrator: a static concentrator with concentration up to 4x. It is mounted south-facing with latitude slope. This concept, although not part of this technology characterization, was found to be a low-cost option comparable with either flat-plate thin film or high concentration PV modules;
- point-focus or dish concentrator at 400x or 1 000x: a reflective dish or a Fresnel lens using high-efficiency concentrator cells operating at a concentration of 400x or 1 000x.

By using optical concentrators to focus direct sunlight onto solar cells, the cell area, and consequently cell cost, can be reduced by a factor of up to one thousand (a 1 000x concentration factor).

This kind of system can be very useful in remote telecommunication sites: the need for a tracker implies the presence of a structure that maintains the panels raised from the land or the roof making it difficult to install in a context where the architectural integration is important. In some remote sites there is not this problem, on the contrary such a system is good because reduces the space occupation that can be a critical element. There is to consider, anyway, that the tracking system can introduce a further source of failure so particular attention is needed in the choice of it. Maintenance costs related to the tracking system have to be considered.

4.3 Wind Turbine Generators

Except for particular sites known for regular wind, wind can be difficult to forecast, it varies from place to place, and from moment to moment.

To be economically practical, a wind turbine should experience year-round average wind speeds of at least 16 km/h. A careful and precise wind survey has to be made before buying a wind system.

4.3.1 Wind Resource

The wind resource - how fast it blows, how often, and when - plays a significant role in its power generation cost. The power output from a wind turbine rises as a cube of wind speed. In other words, if wind speed doubles, the power output increases eight times. Therefore, higher-speed winds are more easily and inexpensively captured.

Wind speeds are divided into seven classes, with class one being the lowest, and class seven being the highest. Their characteristics are shown in the table 3. A wind resource assessment has to be conducted to evaluate the average wind speeds above a section of land (usually 50 metres high), and to assign that area a wind class. Wind turbines operate over a limited range of wind speeds. If the wind is too slow, they will not be able to turn, and if the wind is too fast, they shut down to avoid being damaged.

Table 3: Classes of wind power density

Classes of Wind Power Density at Heights of 10m and 50m				
Wind Class	10 m (33 ft)		50 m (164 ft)	
	Wind Power Density (W/m ²)	Speed m/s (mph)	Wind Power Density (W/m ²)	Speed m/s (mph)
1	0	0	0	0
	100	4,4 (9,8)	200	5,6 (12,5)
	150	5,1 (11,5)	300	6,4 (14,3)
2	200	5,6 (12,5)	400	7,0 (15,7)
3	250	6,0 (13,4)	500	7,5 (16,8)
4	300	6,4 (14,3)	600	8,0 (17,9)
5	400	7,0 (15,7)	800	8,8 (19,7)
6	1 000	9,4 (21,0)	2 000	11,9 (26,6)

The more the wind blows, the more power will be produced by wind turbines. But, of course, the wind does not blow constantly all the time. The term used to describe this is "capacity factor," which is simply the amount of power a turbine actually produces over a period of time divided by the amount of power it could have produced if it had run at its full rated capacity over that time period.

A more precise measurement of output is the "specific yield." This measures the annual energy output per square meter of area swept by the turbine blades as they rotate. Overall, wind turbines capture between 20 % and 40 % of the wind energy. So at a site with average wind speeds of 7 m/s, a typical turbine will produce about 1 100 kilowatt-hours (kWh) per square meter of area per year. An increase in blade length, which in turn increases the swept area, can have a significant effect on the amount of power output from a wind turbine.

The amount of power available in the wind is determined by the equation:

$$W = 1/2 \rho A v^3$$

Where W is power, ρ is air density, A (m²) is the rotor area, and v is the wind speed (m/s). This equation states that the power is equal to one-half, times the air density, times the rotor area, times the cube of the wind speed. Air density varies according to elevation, temperature and weather fronts. For the purposes of calculating wind power, the variations in weather fronts are too small to significantly affect electric power output, so the formula for air density is:

$$\rho = (1,325 \times P) / T$$

Where T is the temperature in Fahrenheit + 459,69 and P is the pressure in inches of mercury adjusted for elevation.

4.3.2 The Mechanics of Wind Turbines

Horizontal Axis Wind Turbines

Modern electric wind turbines come in a few different styles and many different sizes, depending on their use. The most common style, large or small, is the "horizontal axis design" (with the axis of the blades horizontal to the ground). On this turbine, two or three blades spin upwind of the tower that it sits on.

Small wind turbines are generally used for providing power off the TLC, ranging from very small, 250-watt turbines, to 50-kilowatt turbines.

From the outside, horizontal axis wind turbines consist of three major parts: the tower, the blades, and a box behind the turbine blades, called the nacelle. Inside the nacelle is gearbox and generator located, converting motion into electricity. Large turbines do not have tail fins; instead they have hydraulic controls that orient the blades into the wind.

Vertical Axis wind turbine

Vertical wind turbines work independently of the wind orientation and they do not need mechanical system for horizontal rotation, the generator and the gearbox can be placed at the bottom, near the ground, avoiding to put them at the top of the tower. This general conception is generally more simple than for a horizontal wind turbine and it generates less noise. Except for small turbines, this kind of generator does not allow to use a high tower and it has to be considered that the wind speed is usually lower and more turbulent near the ground. Other drawbacks are lower power range and efficiency than the horizontal axis type, typically 50 % lower, low start torque, and pulsating torque at operation, causing mechanical fatigue.

Also in the vertical configuration there is a control logic that stops the generator in case of high wind.

Vertical wind turbines may also have efficient, direct driven internal generators and may, under certain conditions, be mounted on the same mast as other equipment.

4.4 Micro hydro generators

Micro hydro units convert the energy of flowing water into electrical energy. The energy produced by them is renewable and the process does not emit polluting gases.

Micro hydro generators used in stand alone power systems can be DC units, designed to charge a battery bank or to power directly TLC's loads, or AC units designed to supply the household loads directly. Specific micro hydro generators can operate in parallel with the grid in order to resell the green energy produced in excess

In micro hydro systems water turns a wheel or a runner (like a propeller) to rotate a turbine and produce electricity. The wheels come in different shapes and sizes depending on the site and the type of turbine.

There are two types of micro-hydro turbines: impulse and reaction.

Impulse turbine wheels run freely in air. Water is directed onto the runner by jets and then drops away, its energy depleted. Impulse turbines are usually installed on sites with heads greater than ten metres and are the most common type of turbine installed in a domestic system.

Reaction turbine runners rotate fully immersed in water in a sealed case. After passing the turbine the water continues to the waterway via a pipe. These are usually installed in low water head applications.

A micro hydro generator is composed of the turbine, gear-box, generator and control; all parts are built in one unit.

Cross-flow turbines, small Pelton and Kaplan turbines are installed for the utilization of locally available small and medium water quantities.

The cross-flow (or Banki) turbines, like Kaplan, are suitable for heads from 7 m to 60 m and effective flow rates ranging from 20 l/s to 800 l/s. It offers an excellent solution that reconciles quality, performance and price.

Pelton and Kaplan turbines are used for higher head, most efficient at head > 50 m, suitable for heads from 20 m to 180 m, even up to 1 000 m deployment in Norway. Effective flow rates are ranging from 0,5 l/s to 100 l/s.

The data concerning head and available water flow are fundamental for calculating the output power of a micro hydro generator (see figure 1). By intersecting the Y co-ordinate, which shows the head in metres, with the X co-ordinate, which shows the flow in litres per second, the resulting point will be found between different diagonal sections indicating the electrical power generated, expressed in kW. The coloured areas highlight the possible operating points of the various micro hydro generators available.

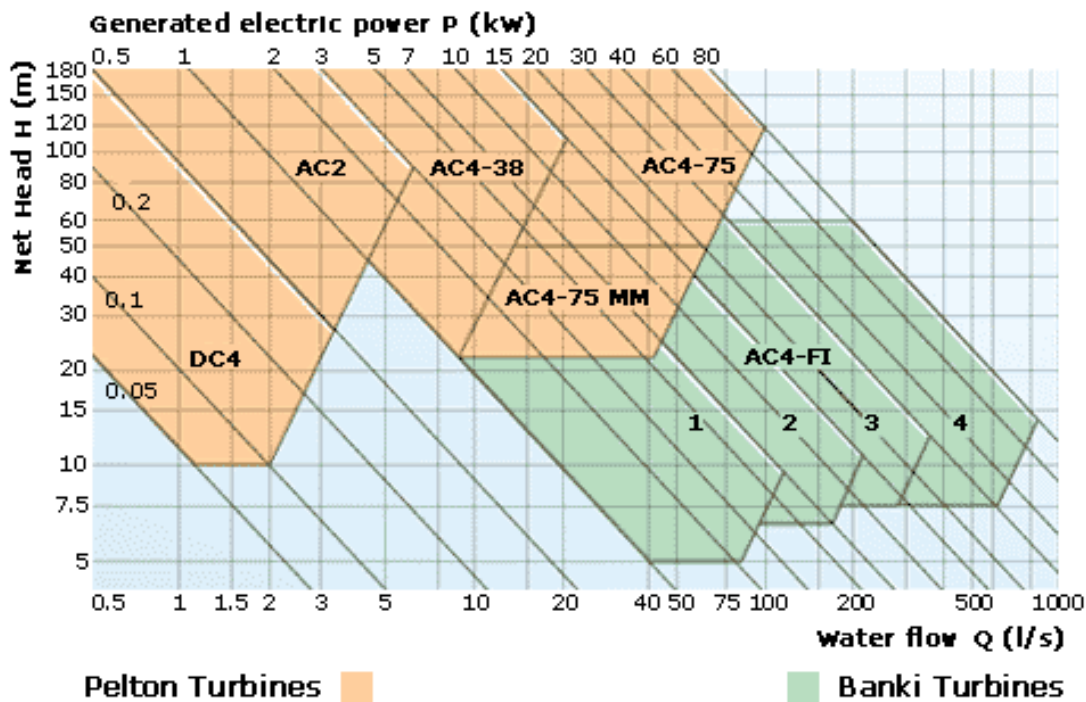

Figure 1: Output power of a micro hydro generator

The output power of a micro hydro generator is obtained by dividing the product of the outflowing water Q (in litre/sec), the fall H (in metres) and the system efficiency by 102:

$$P = Q \times H \times \eta / 102 \text{ (kW)}$$

The system efficiency is the product of the efficiency of the turbine, speed transmission and generator.

4.5 The Stirling machine

The Stirling machine is an external heat engine belonging to the family of the so-called 'hot air engines'. The hot source of this thermo dynamical machine can come from a fluid (liquid or gas) heated by the sun in a linear parabolic concentrator or from a burner using fuel, which can be bio-fuel (see figures 2 and 3)

An improved design of the Stirling machine is the Mr. Ericsson motor. In 1833, John Ericsson invented a thermal air engine composed of a compression cylinder equipped with valves, a heat recovery exchanger, a heat exchanger for the hot source and an expansion cylinder also equipped with valves. This engine seems relevant for small power solar thermodynamical energy system. The thermodynamical cycle in this machine is a Joule cycle, equivalent to the heat recovery gas-turbine cycle. Figure 4 presents the basic configuration scheme. This configuration can easily be « hybridized » (see figure 5), e.g. by using another thermal energy source than the sun – it can be fuel combustion. There is fuel tank G , a burning chamber CC , a heat exchanger « heater » H_f , a pre-heating exchanger used for combustion air P and the exhaust gas chimney (Chem).

The efficiency with solar heat at around 400 °C is around 10 % to 15%. When using a fuel burner, the temperature can be around 800 °C and the efficiency can reach 25 % to 30 % at high load rate.

In addition the solar heat can be stored to reduce fuel consumption and in replacement of electricity storage in battery. This thermal storage is represented on figure 5. A tank S is crossed by a working fluid in serial with the solar heater H_s or the fuel heater H_f . This tank contains a Phase Change Material (PCM). About the PCM thermal storages, the considered material is an eutectic mixture of $NaCl/MgCl_2$, whose melting temperature equals 442 °C, and the melting latent heat equals 280 kJ/kg.



Figure 2: Concentrator system

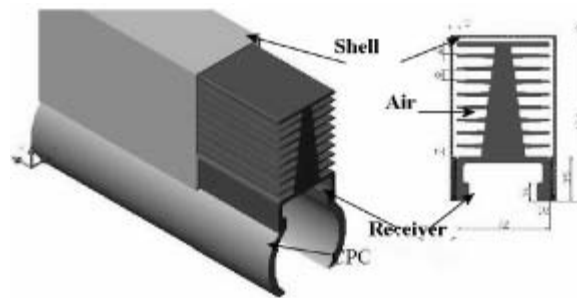

Figure 3: Concentrator second stage (CPC) and « heater »

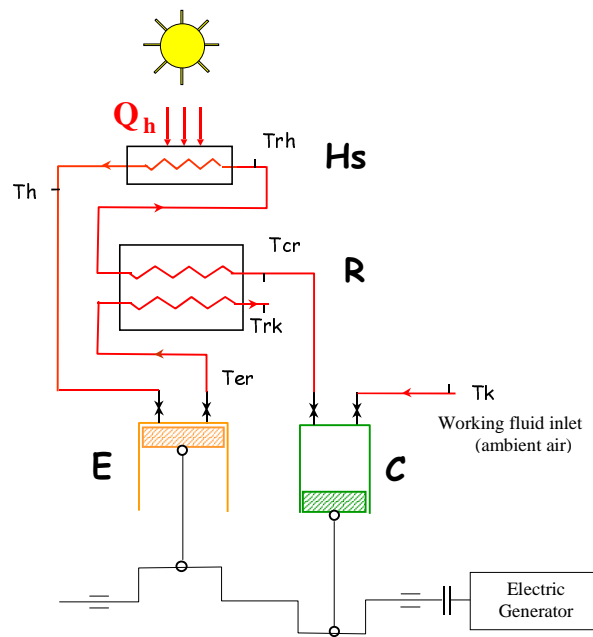

Figure 4: Basic configuration

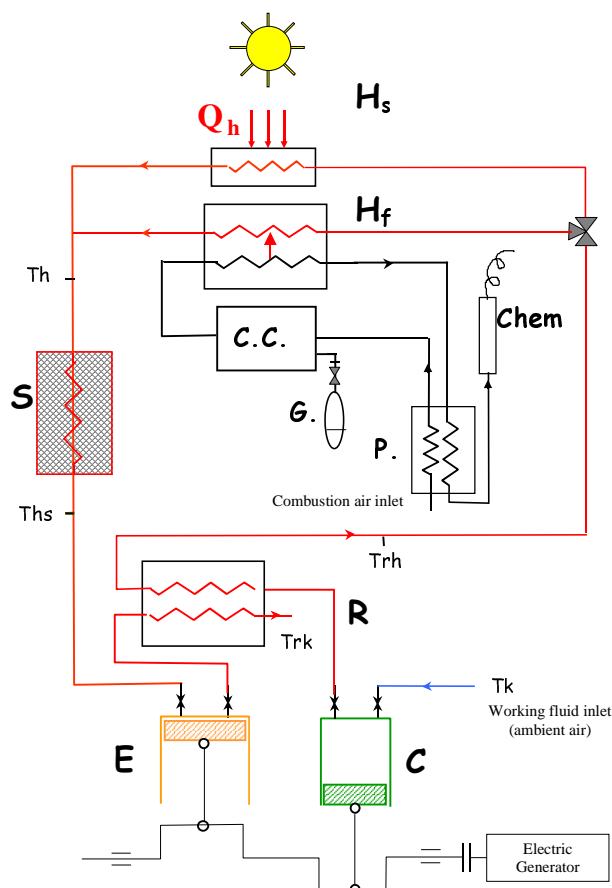

Figure 5: Hybrid system with storage

The advantages of such machine should be:

- long life time and no noise because no internal explosion;
- high efficiency (comparable to diesel engine);
- possibility to use any fuel with the appropriate burner or any source of heat at the right temperature range;
- as a consequence, native hybrid configuration with fuel or sun heat;
- very low pollution with sun heat or total combustion of fuels in good burners.

There are also some difficulties or drawbacks:

- low speed around 500 rpm to 1 500 rpm increasing the size : either the electric machine is bigger, either a speed multiplier device is required;
- only at development stage;
- bigger machine than fast rotating engine;
- thermal inertia avoiding fast speed regulation (not a problem for DC power generation).

Figure 6 shows a prototype machine of the Sandia Labs with a Stirling machine at the centre of a concentrator dish with more than 30 % efficiency, while figure 7 shows a prototype of Ericsson machine from LaTEP thermodynamic laboratory from Pau University.



Figure 6: Stirling machine heated by sun concentrator (Sandia labs 2008)



Figure 7: Ericsson machine prototype (LaTEP Pau 2008)

5 Energy storage and short term power backup

Energy Storage is necessary in these cases:

- a) power supply of a critical load when the primary energy source (mains) is not available in case of maintenance or a fault (backup power);
- b) when there is a need of an additional power, unsustainable by the standard power infrastructure;
- c) when energy in an useful form is advantageously available from various sources and cannot be used as there is not a correspondent demand.

Case a) is well known as backup power for critical apparatus, uninterruptible power supply, telecommunications systems, power plants and medical.

Case b) is becoming more and more popular with the energy storage used to improve the quality of electrical energy distribution in case of sudden perturbations (voltage sags), to minimize the effects of peak demands and/or, with a better stability.

Case c) is typical of renewable energy sources, such as photovoltaic or eolic systems, with a typical intermittent availability.

Combinations of these cases are also possible and load levelling is one example of case b) and c).

The following clauses are focused on energy storage systems for applications that require a significant amount of energy. Among the storage system, the most popular is that of electrochemical cells (batteries) and therefore focus will be on batteries for energy storage. Small batteries such as those used in portable/consumer applications are not dealt with.

The adoption of an energy storage system needs to be evaluated in correlation to the requirements of the application and to the cost of alternative solutions. In general all energy storage systems can be replaced by additional conventional energy generation, however this can lead to oversizing (due to high power and fast response needs), with poor efficiency in the use of energy sources and to bigger investments.

Electrochemical secondary cells/batteries, in the past as well as nowadays, are used in most of the energy storage applications. The most popular is the lead-acid chemistry, and other battery chemistries can offer alternative solutions, with alkaline cells, lithium based cells and high temperature cells. Performances, availability, cost and long term reliability are the criteria useful for the selection of the most suitable technology.

Other energy storage technologies, with different characteristics and output, are available. They include:

- Supercapacitors.
- Flywheels.
- Super Magnetic Storage Systems (SMES).
- Pumped Hydrostorage and Compressed Air.
- Fuel Cells (see also the clause on generation of the present document).

Table 4 and figure 8 summarize the various energy storage technologies.

Table 4: Energy storage technologies

System	Energy Input	Energy Storage	Energy Conversion
Batteries	Electricity	Anode/Cathode Materials	Anode/Cathode Materials
Fuel Cells	Hydrogen	Compressed Gas Tank	Fuel Cell
	Hydrocarbons	Tank	Reformer + Fuel Cell
Supercaps	Electricity	Double Layer	Double layer discharge
SMES (See note 1)	Electricity	Magnetic Field	Electromagnetic
Flywheels	Electricity	Cinetic	Electric Generator
Pumped Hydrostorage	Electricity	Gravitational	Turbine/Generator
CAES (See note 2)	Electricity	Pressurized Tank	Turbine/Generator
ICE + GenSet (See note 3)	Hydrocarbons	Tank	Carnot Cycle Electric Generator
NOTE 1: Super Magnetic Energy Storage.			
NOTE 2: Compressed Air Energy Storage.			
NOTE 3: Internal Combustion Engine and Generator.			

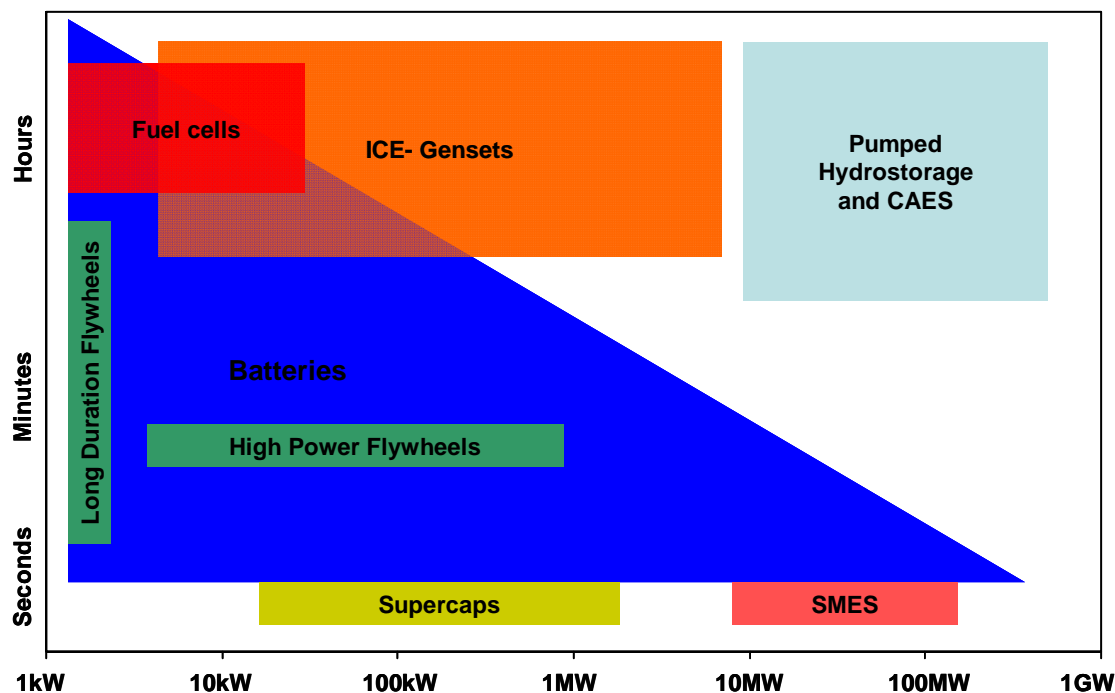

Figure 8: Classification of energy storage system according to the power/energy output

5.1 Batteries

Secondary electrochemical cells, also known as rechargeable batteries or batteries, are able to store electricity in a chemical state as described in figure 9.

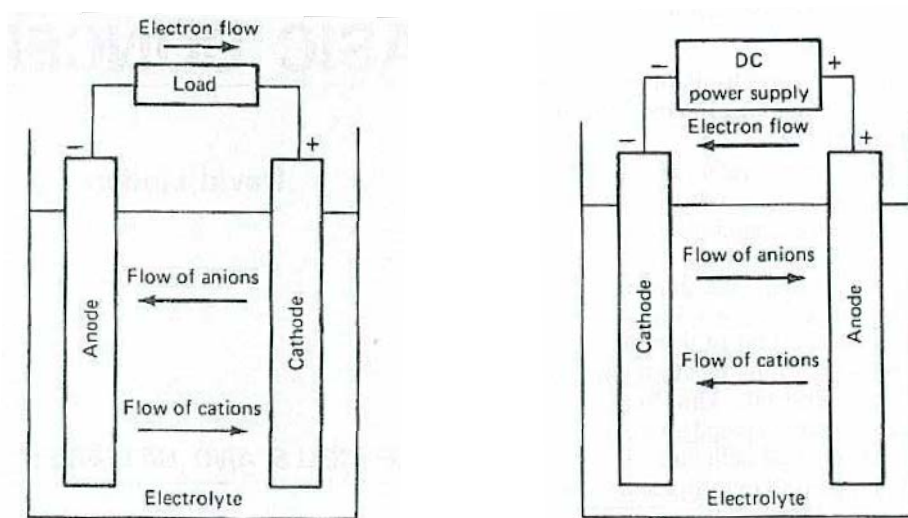

Figure 9: Electrochemical cell scheme and electrical operation of a cell in charge (left) and in discharge (right)

Batteries were the first form used to store electricity and are now largely used in almost all the electricity applications. The lead-acid chemistry has been largely developed and engineered since its discovery about 150 years ago and has achieved a large scale manufacturing and commercialization development. The Nickel-Cadmium chemistry that has been discovered in the beginning of the 1900's, has seen a lower development in Telecom, mostly because of a higher initial cost; this technology that offers long life and high reliability is used in hot climates or in severe environment. In the last decade Nickel-Metal Hydride and Lithium-Ion batteries have seen important developments and have achieved a significant market penetration.

Batteries are generally characterized by high energy efficiency and an almost instantaneous availability. The energy stored can be delivered in short times (peak power demands) as well as over several hours of energy backup. Their performances and actual lifetime are strongly dependant on the service operation, with particular emphasis on the recharge procedure and the environmental conditions. Batteries represent a very reliable form of energy storage and as they generally contain metals and other materials with a significant environmental impact, their disposal should be controlled providing the necessary infrastructures.

Battery Technologies

In telecommunication sites the most used system to store energy is represented by batteries. They are charged by the same energy source that powers the load and then are used to feed it in case of main power source's failure.

There are many battery types but the most used is the lead acid one. There is a lot of research to improve battery technology to have a high energy density and a long life. Good results have been reached for consumer electronics where there are various high performance batteries. In the following tables there is a comparison between some types of batteries.

Tables 5 and 6 provide an overview of typical battery characteristics.

Table 4 gives the following parameters and in particular:

- 1) Faradic Efficiency (Ah efficiency) = (Discharged capacity [Ah]) / (Recharge capacity [Ah]) - in EN 62093 [i.13] the Ah-cycling efficiency is clearly expressed.
- 2) Energy Efficiency = Discharged energy [Wh] / (Recharged Energy [Wh]).
- 3) Energy Density (Wh/l) = (Nominal or Discharged Energy [Wh]) / (Volume of the Battery or the Module [litre]).
- 4) Energy Density (Wh/kg) = (Nominal or Discharged Energy [Wh]) / (Weight of the Battery or of the Module [litre]).

Table 5: Overview of typical battery characteristics

Type	Electrolyte	Faradic Efficiency (%)	Energy efficiency [%]	Energy density [Wh/kg]	Power densities		Life cycle [cycles number] at 20 °C	Operating temperature [°C]
					Peak (W/kg)	continuous (W/kg)		
Lead-acid LA	H ₂ SO ₄	Up to 99 %	75 % to 90 %	20 to 35	120	25	500 to 2 000	-20 to 60
Nickel-Cadmium Ni-Cd	KOH	Up to 99 %	70 % to 87 %	40 to 60	300	140	500 to 2 000	-40 to 60
Ni-metal-hydrid Ni-MH	KOH	Up to 99 %	70 % to 87 %	60 to 80	440	220	500 to 2 500	10 to 50
Lithium-ion Li-ion	LiPF ₆	Up to 99 %	70 % to 95 %	100 to 200	720	360	500 to 4 000	-20 to 60

Table 6: Comparison between various types of batteries (2/2)

Category	Chemistry	Manufacturers Developers	Development Stage	Specific Energy		Management System	Safety Risks
				Wh/kg	Wh/l		
Ambient Temperature Aqueous Electrolyte	Lead-acid LA	worldwide	well established	30	40 to 100	not used	accepted
	Nickel-Cadmium Ni-Cd	worldwide	established	50	40 to 100	not used	accepted
	Nickel-MeHydrid Ni-MH	worldwide	established	60	130	on charge	accepted
	Nickel-Zinc Ni-Zn	Asia-France	not established	70	70	not used	accepted
Lithium	Li-Ion	worldwide	established small sizes	150	Up to 200	necessary	concern
	Li-Ion Polymer	worldwide	established small sizes	130	Up to 180	necessary	limited
	Li-Metal	Europe-Asia	development	180	150	necessary	concern
	Li-Metal Polymer	Canada	established	120	120	necessary	concern
High Temperature Cells	Sodium Sulphur-Na-S	Japan	established	120	140	necessary	concern
	Sodium Metal Chlorides	Switzerland	established	120	120	necessary	limited

Rechargeable batteries are called accumulators or secondary batteries, while the term primary batteries is used for single use ones.

The evolution of battery construction has led to making sealed casing, thin-tube electrodes and electrolyte circulation that are methods to reduce internal resistance and to avoid maintenance.

The energy density increases with temperature and decreases with the discharge rate.

To increase the life cycle and the performance in a context where frequent charge and discharge cycles are needed (that is the case of backup batteries in a remote site, maybe equipped with a not constant power source such as a photovoltaic or wind generator) cycling batteries are used.

So this type of battery has to be used in a telecommunication site for backup purposes.

Batteries with aqueous electrolyte operating at ambient temperature were the first chemistries to be developed, starting more than one century ago.

They are manufactured on a large mass scale and can benefit of a long term research and development activity, of continuous improvements of design and process manufacturing, driven by competitiveness and cost efficiencies.

They are characterized by a high level of reliability, availability. Their performances in terms of specific energy are good and suitable for the majority of conventional applications. However they are lower as compared to other chemistries that have been introduced in the last decades.

The batteries with aqueous electrolyte can be grouped into two categories:

- batteries with acid electrolyte, i.e. the lead acid battery;
- batteries with alkaline electrolyte, or alkaline batteries, of which the most popular are the nickel-cadmium (Ni-Cd) batteries and the nickel-metal hydride (Ni-MH) batteries.

In batteries with aqueous electrolyte, in addition to the primary electrochemical reactions, secondary (side) reactions take place, which effects are:

- reduction of their efficiency;
- progressive water consumption (at different rates according to the various technologies) which may require replacement operations;

- release in the surrounding environment of gases from the electrolysis of water.

This Directive 2006/66/EC [i.14] applies to all types of batteries and accumulators, regardless of their shape, volume, weight, material composition designed for industrial or professional uses.

5.1.1 Lead-acid batteries

Lead acid batteries are made with lead based electrodes and, in the charged state, lead dioxide as positive active material and sponge lead as the negative one. The electrodes are electrically insulated by a separator with ionic conductivity. The electrolyte is a solution of sulphuric acid.

The basic reactions are, at positive and negative plate, the following ones:

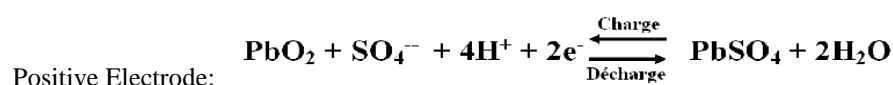
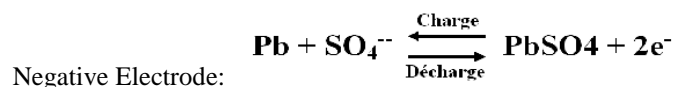

An additional recombination reaction in VRLA is the one in which the H^2 produced at positive plate during charge migrates to negative plate where it efficiently recombines with O^2 produced, thereby reducing loss of water.

Cells are made with a stack of alternated positive and negative electrodes and a separator between two consecutive electrodes. Electrodes of the same polarity are connected together through led bars that end to the outer with the positive and the negative terminal. The stacks are housed in a single container (2 V cell) or in a multi-compartment container (block with $n \times 2$ V, where n is the number of cells connected in series).

Lead acid technologies are differentiated by the type of positive electrode (plate) and by the electrolyte.

In the past, when only conventional cells (also called vented or flooded) cells were available, there was only one type of electrolyte "configuration", i.e. a solution partly absorbed in the active materials/separators and partly in a free liquid phase.

The main (and only one) differentiation in technology was that of positive plates with:

- pasted plates (also called flat plated);
- tubular plates;
- Plantè plates.

In the last two or three decades, with the advent of the so-called Valve Regulated Lead Acid (VRLA) batteries, another important differentiation of the lead acid technologies emerged, i.e. in terms of the electrolyte condition, with the following three types:

- free liquid electrolyte, with vented cell;
- absorbed electrolyte, where the free liquid electrolyte is retained in absorbing glass mat (AGM) which acts also as separator;
- gelled electrolyte, where the free liquid electrolyte is transformed in a gel (semisolid) phase by means of additives.

Lead-acid batteries constitute one of the more economical options for energy storage in renewable energy generation plants, particularly when they are in a standalone configuration, i.e. not connected to a power grid.

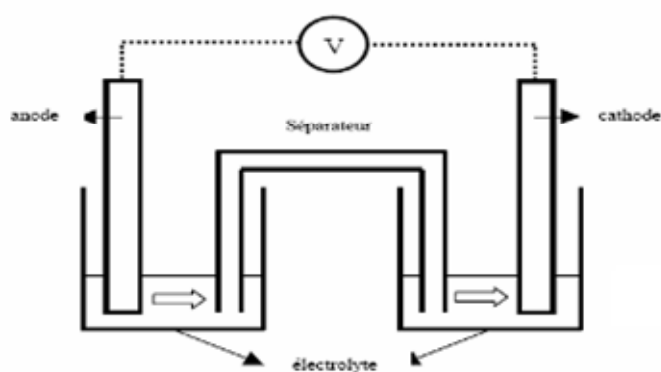

Figure 10: Lead-acid battery installation in a 500 kW renewable sources power plant with combined eolic and photovoltaic generation

5.1.2 Nickel-Cadmium batteries

Ni-Cd chemistry features Nickel Hydroxide as positive electrode, Cadmium as negative electrode and an aqueous solution of potassium hydroxide as electrolyte. Ni-Cd cells have been produced from the beginning of the 1900's, mostly in Europe, North America and in Asia. Several electrode technologies are available. Cells are made with a stack of alternated positive and negative electrodes and a separator between two consecutive electrodes. Electrodes of the same polarity are connected together through internal collector which ends to the outer with the positive and the negative terminals. The stacks are housed in a single container (1,2 V per cell) or in a multi-compartment container (block with $N \times 1,2$ V, where N is the number of cells connected in series). For a typical 48 V application, 36 to 38 cells are connected in series.

The basic reactions are:



Anode's oxidation (2 electrons are released):

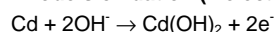

Cathode's reduction (2 electrons are absorbed):

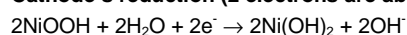

Global oxy-reduccion reaction (transfer of 2 electrons):

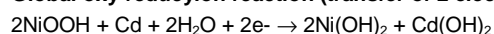

Figure 11: scheme of a Ni-Cd cell with electrochemical reactions

It can be seen that water is participating to the reaction but not KOH and additive, which is a huge difference compared to Lead-Acid; by this way Ni-Cd offers a progressive loss of capacity in operation without risk of sudden death.

The higher initial cost compared to lead-acid is balanced by longer life-time and less maintenance and water refill in hot climate, or by much better performance without over sizing at low temperature. Ni-Cd is characterized by a high level of reliability; the progressive and predictable loss of capacity with ageing may be also an advantage.

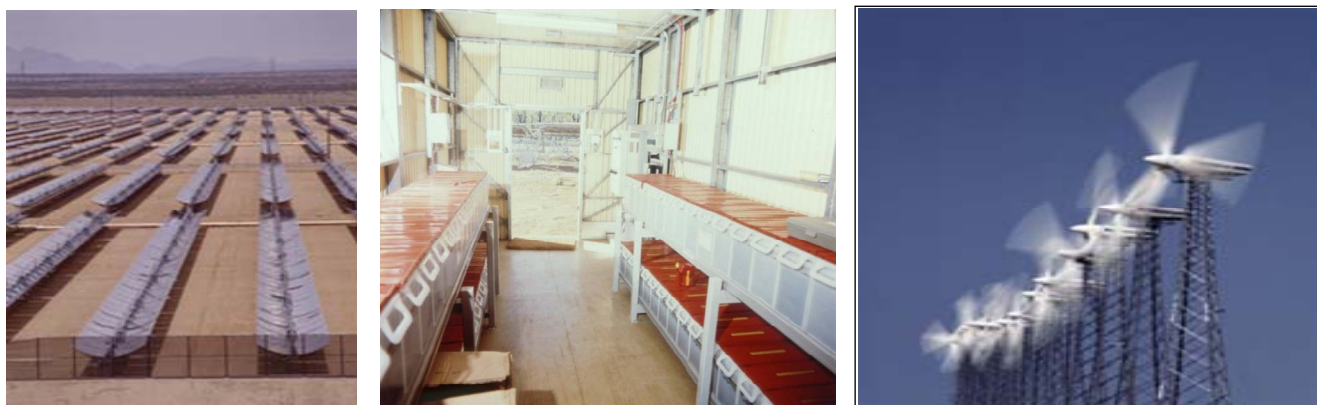

Figure 12: Ni-Cd battery installation for renewable sources power plant

5.1.3 Nickel-Metal Hydride batteries (Ni-MH)

Ni-MH cells use as negative electrode a combination of metallic alloys which are able to absorb and release hydrogen in volumes up to a thousand times their own volume. The positive electrode is Nickel Hydroxide as in Ni-Cd batteries. The electrolyte is an aqueous solution of potassium hydroxide. Small cylindrical cells are mass produced, while the production of large size Ni-MH cells is limited to a few companies.

5.1.4 Nickel-Iron batteries (Ni-Fe)

The Ni-Fe chemistry was introduced more than one century ago. It proved a very robust battery, tolerant of abuse and long lasting. The issues related with its low efficiency, a very high self-discharge and gas emission prevented a significant worldwide diffusion of Ni-Fe cells and they have been progressively replaced by Ni-Cd cells.

5.1.5 Nickel-Zinc batteries (Ni-Zn)

This alkaline battery uses a zinc electrode which makes it very interesting in terms of material cost and environmental compatibility. Cell voltage is one of the highest among alkaline cells (1,65 V vs. 1,25 V of Ni-Cd or Ni-MH) which results in a very high specific energy.

However the zinc electrode is still affected by a very short life and this fact has always prevented the diffusion of this technology. New efforts are being carried out to overcome the anode problems, with several research centres being involved.

5.1.6 Lithium Ion batteries (Li-Ion)

Lithium-ion cells use a transition metal oxide as cathode (typically LiCoO_2 , LiNiO_2 , LiMn_2O_4 and Fe_3PO_4), carbon material as anode (graphite, coke etc.), and a liquid electrolyte that is absorbed by a polymeric foil. The electrolyte consists of an organic solvent (typically ethylene carbonate with several additives) in which a lithium salt (LiPF_6 or LiClO_4) is dissolved.

In lithium-ion cells operating within the allowed voltage range, metallic lithium is not present as it is always in the ionic form. The ions are intercalated in the crystalline structure of the positive and the negative electrodes.

The reactions work like a rocking chair, with Li ion migrating from one electrode to the other.

While small lithium-ion batteries dominate the portable market, medium and large size batteries are not available in large scale but expert forecast mass development of this technologies for EV and Renewable Energy in the coming years. The Lithium ion systems are characterized by very high energy density, excellent cycling capability, high power capability and maintenance free design.

5.1.7 Lithium Ion Polymer batteries (LiP-Ion)

The Lithium Ion Polymer is a solid state cell, with lithiated cobalt oxide as cathode (on an aluminium collector), graphite as anode (on a copper collector) and a polymeric separator.

This technology, developed by several companies, is characterized by very high performances.

5.1.8 Lithium Metal Polymer batteries (LMP)

The electrochemical configuration of the LMP cell consists of a metallic lithium anode, a solid dry conductive polymer electrolyte and a vanadium oxide cathode on an aluminium current collector. The conductive polymer should be kept at temperatures between 40 °C and 60 °C in normal operation to ensure good ionic conductivity.

5.1.9 Sodium sulphur (Na-S)

The sodium-sulphur cells operate only at high temperatures (300 °C to 350 °C). Both electrodes are in a liquid phase, while the separator is in a ceramic form (β'' -alumina). Presently only some industry produces Na-S cells to be used in large battery modules (50 kW) for stationary applications, such as load levelling, peak shaving and improved quality in the electrical energy distribution. The Na-S cell development has been discontinued for safety issues by all developers focused in EV (Electrical Vehicle) applications and applicability in TLC area needs to be studied.

5.1.10 Sodium-metal-chloride

The sodium-metal chloride cell is derived from the sodium-sulphur cell. It can operate only at high temperatures (300 °C to 350 °C). The cathode consists of metallic powder (Ni, Fe) in a tetrachloridealuminate catholite, while the separator is in a ceramic form (β'' -alumina), which features a fast transport rate for sodium ions. In the charged state sodium is transferred to the anode and metal chlorides are produced at the cathode. Sodium metal Chloride systems are characterized by very high energy density, excellent cycling capability, maintenance-free design and stable performance in a wide temperature range.

This technology has provided unlevelled performances in EV (Electrical Vehicle) applications (the most demanding duty for batteries) and applicability in TLC area needs to be studied.

5.2 Supercapacitors

Supercapacitors store electrical energy in the form of an electric field between two electrodes. They have very low internal impedance and can be recharged in seconds. They are characterized by very high values of specific power (W/kg) and are particularly suitable for peak power applications. On the other side their specific energy (Wh/kg or Wh/l) is much lower (about ten times) than that of batteries and, in addition, they feature on discharge a voltage profile decreasing from the nominal voltage to zero, thus limiting the useful energy in actual applications approximately to 1/4 of the available energy (dictated by the minimum operational voltage of the apparatus).

In short, supercapacitors are very good in providing peak power demands but they store low amounts of useful energy and cannot replace batteries in the majority of the current applications. When integrated with a battery, they may significantly increase the high rate performance of the storage systems and extend the overall service life as they can relieve the battery from high power drains, which have an important effect in its degradation.



Figure 13: Supercapacitor Bank, 360 V -150 kW 320 WHr

Open issues:

- operating temperature impact on supercapacitors life (higher temperatures brings to reduced lifetime);
- environmental aspects at the dismissal at the end of life;
- safety (risk of explosion).

5.3 Fly wheels

Flywheels store energy mechanically in the form of kinetic energy, i.e. a mass rotating about an axis. A flywheel energy storage system is an electro-mechanical device that couples a motor/generator with a rotating mass. The motor draws power from the grid to spin the rotor of the flywheel. During a power outage, voltage sag, or other, the kinetic energy stored in the rotor is transformed into electric energy by the generator, and the energy is delivered to the load.

In order to optimize the energy-to-mass ratio, the flywheel needs to spin at the maximum possible speed because kinetic energy only increases linearly with mass but goes as the square of the rotational speed.

Traditional flywheel rotors are usually constructed of steel and are limited to a spin rate of a few thousand Revolutions Per Minute (RPM). Advanced flywheels constructed from carbon fibre materials and magnetic bearings can spin in vacuum at speeds up to 40,000 RPM to 60,000 RPM.

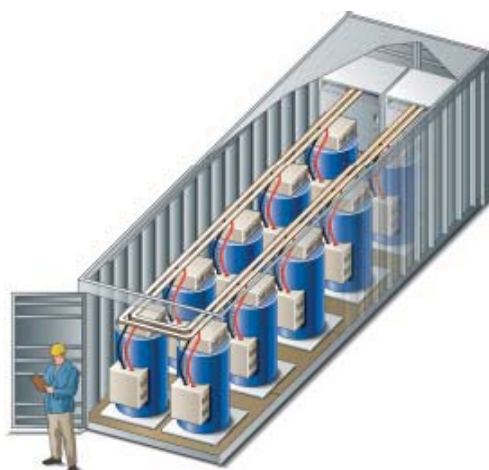

Figure 14: Flywheel system example

The flywheel provides power during the bridging time period between the loss of grid power and either the return of utility power or the start of a back-up energy system (diesel genset). The typical power range of this backup solution is from some kW to tens of MW, for backup times of seconds or hours.

5.4 Super Magnetic Storage Systems (SMES)

Superconducting magnetic energy storage systems store energy in the field of a large magnetic coil with direct current flowing. It can be converted back to AC electric current as needed. Low temperature SMES cooled by liquid helium is commercially available. High temperature SMES cooled by liquid nitrogen is still in the development stage and may become a viable commercial energy storage source in the future. A magnetic field is created by circulating a DC current in a closed coil of superconducting wire. The path of the coil circulating current can be opened with a solid state switch which is modulated on and off. Due to the high inductance of the coil, when the switch is off (open), the magnetic coil behaves as a current source and will force current into the capacitor which will charge to some voltage level. Proper modulation of the solid-state switch can hold the voltage across the capacitor within the proper operating range of the inverter. An inverter converts the DC voltage into AC power. SMES systems are large and generally used for short durations, such as utility switching events.

5.5 Pumped hydrostorage and compressed air

Pumped hydro storage is a conventional energy storage technology utilized by the electrical generation industry. Water is stored in two basins at different levels: when surplus energy is available, water is pumped from the lower level to the upper level, during peak hours the flow of water is reversed to generate electricity. The power output and the cost efficiency of pumped hydro storage depends on the difference in height. Worldwide there are about 100 GW of pumped hydrostorage installations.

Compressed air energy storage uses pressurized air as the energy storage medium. An electric motor-driven compressor is used to pressurize the storage reservoir using off-peak energy and air is released from the reservoir through a turbine during on-peak hours to produce energy. The turbine is essentially a modified turbine that can also be fired with natural gas or distillate fuel. Ideal locations for large compressed air energy storage reservoirs are aquifers, conventional mines in hard rock, and hydraulically mined salt caverns. Air can be stored in pressurized tanks for small systems.

5.6 Reliability of energy storage systems

Conventional Batteries

Conventional batteries, basically Lead- acid (LA) and Ni-Cd with aqueous electrolyte, are usually operated with no management systems, are usually not protected against abuse conditions such as overcharge and over-discharge and frequently there is not any battery disconnecting device. In the user's mind they are called to deliver power under every operating condition, also beyond the limits, that could create irreversible damages which would require replacement.

In this term conventional batteries can be considered as a simple system and therefore offer a high level of reliability.

In addition, the fact that conventional battery are not disconnected whatever the operating conditions, including abusive conditions, can be seen also as an advantage .

High-energy batteries

High-energy batteries such as lithium based or high temperature cells are all integrated with a Battery Management System (BMS).

The purpose of the BMS is to operate the battery within the optimal conditions and to prevent the operation in case of overcharge, over-discharge and over-temperature, with some technology even at the single cell level.

In low power, low voltage batteries this is easily achieved with simple electronic devices. In higher voltage, high energy battery systems will require power electronics and/or mechanical switches.

5.7 Safety of energy storage systems

All energy storage systems present safety risks because of their nature. The risks are associated with:

- the electrical potential between the terminals, which may be very high in large high-voltage systems;
- operational release of substances to the environment;
- leakage of aggressive or toxic substances;

- development of violent reactions under abuse conditions or internal failure.

Conventional Batteries

The safety issues related to the operation of conventional batteries are all well known and in general properly dealt with. The most important are:

- risk of electrical shock or external short circuit, prevented with shrouding of live parts or design of the cell;
- hydrogen gas build up, whose risks are prevented with an adequate ventilation;
- release of corrosive vapour with LA, which has been dramatically reduced with the use ceramic filters and very low gassing rate recombinant cell designs;
- possible thermal instability with LA which may lead to the destruction of the battery and possibly damage to the surrounding equipment.

The lead-acid and Ni-Cd batteries battery installation should be done in accordance to EN 50272-2 [i.15]. The standard applies to stationary secondary batteries and battery installations with a maximum voltage of DC 1 500 V (nominal) and describes the principal measures for protection against hazards generated from:

- electricity;
- gas emission;
- electrolyte.

EN 50272-2 [i.15] provides requirements on safety aspects associated with the erection, use, inspection, maintenance and disposal.

Fire or explosions events with conventional batteries involved happen on a very small extent based in percentage terms, but they happen. There are a number of root causes, from equipment fault to abuse, manufacturing defects, unsafe behaviour and inappropriate design. The fact that conventional batteries have been used for many decades and a limited number of incidents have occurred, lead to a general acceptance of these events.

High energy batteries

High-energy batteries, such as lithium based or high temperature cells, feature components potentially very reactive, do not tolerate abuse and cannot be overcharged or over-discharged and irreversible damages can occur. A dedicated Battery Management System equip such type of battery units to prevent any safety issue and offer the best performance of these technologies. This BMS will be designed to ensure vital functions even in case of failure (for instance redundant independent circuitry) and provide an acceptable level of safety for those battery technologies.

The chances of a mass diffusion of high energy batteries in power applications, are directly linked to the development of intrinsic safe battery units including reliable Battery Management System (BMS).

6 Power Systems

This part of the present document describes the alternative energy converters that actually are considered more interesting as source of power for telecommunication application.

6.1 Fuel cell systems

As a primary source, PEM fuel cells are not competitive. Direct hydrogen systems are not practical because of the cost and logistics related to the fuel. Another problem is the limited life of the main component, the fuel cell stack. Air cooled systems life time is approximately 2 000 hours, while liquid cooled systems may last longer, with manufacturer life time figures ranging from 5 000 to 20 000 hours.

Systems based on liquid fuels will eliminate the problems related to extensive supply of compressed hydrogen. These systems are more complex and reliability will consequently be a challenging issue. The life is in the lower interval of the direct hydrogen systems. On the contrary PEM fuel cell systems are expected to be an important component in many future critical backup power systems for several reasons, the first being that in backup operating mode they require little or no maintenance and can offer high performances over a wide range of climatic conditions. Finally fuel cells are easily scaled to meet increasing run time requirements by simply storing more fuel at the site or adding a hydrogen generation module.

Fuel Cell power system could be used for several telecommunication applications:

- back-up power generator for grid-connected sites;
- secondary power source for PV/Wind/battery hybrid applications. In this application fuel cell is used as a battery charger and will provide the additional power to compensate for the deficit of renewable energy (but the OPEX of this method is very high, with waste of energy and H₂).

The scheme below shows a typical installation of a backup with a fuel cell system: the unit is connected to the DC bus. The start-up procedure of the cell is often set through a clean contact able to check the presence of the primary energy source (the grid). There is also an automatic start-up procedure that checks the depth of discharge by the battery voltage and starts the fuel cell if its level decreases below a fixed value. In this way the unit is also able to face the failure of one or more rectifiers during the normal working condition (with the grid connected).

Since the fuel cell has a start-up time (from some seconds to some minutes) it is required to provide a battery or a supercapacitor as a buffer for the load. The autonomy of the buffer has to be calculated according to the start-up time of the fuel cell and the load power requirement.

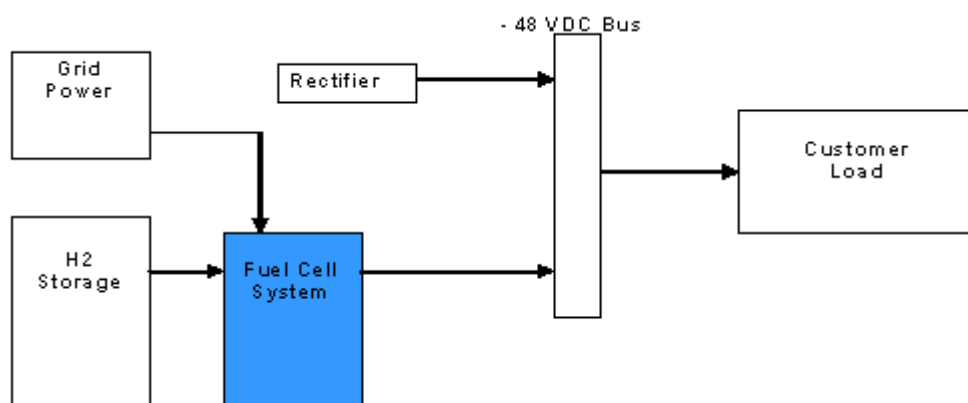

Figure 15: Back-up power application with H₂ tank storage or liquid fuel reformer (grid-connected)

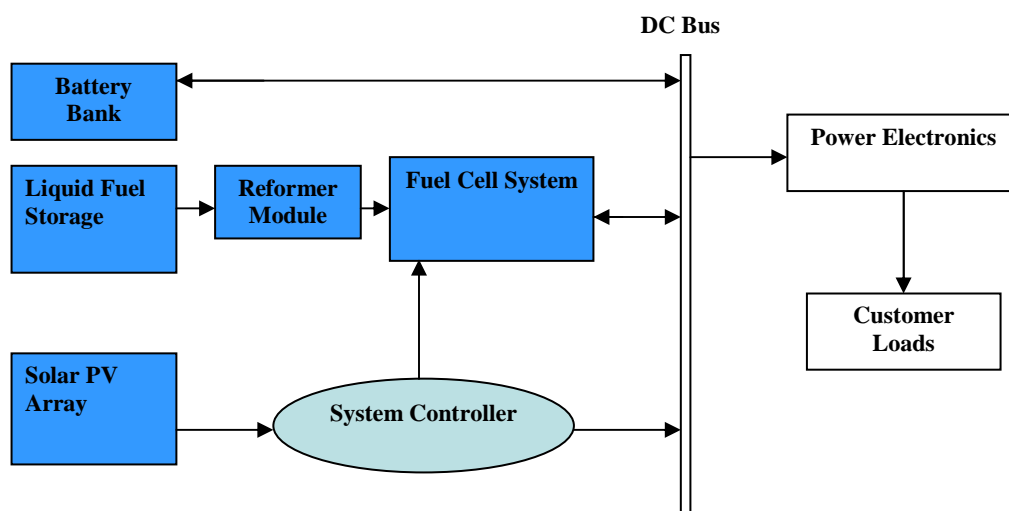

Figure 16: Renewable (PV/Wind) hybrid solution (off-grid)

6.2 Photovoltaic systems

A PV system is the assembly of the mechanical, electrical and electronic devices able to capture the solar energy and produce electrical energy. In the following clauses the different application scenarios of this technology are described, specifically:

- 1) **Direct connection:** in this case the load is directly connected to the energy sources. The power supply device depends strictly on the presence of the solar radiation and a fine regulation of the output power is not possible. This configuration is not used in telecommunication sites due to the high availability requirements of the operation.
- 2) **Off-grid connection:** in this case the energy is supplied to the load and stored in the external batteries which supply the load when the PV is not able to cover all the energy demand. This solution is normally used when the TLC plant is located in a remote site and the electrical grid installation results too much expensive (i.e. a mountain hut or an island).
- 3) **In-grid connection:** two different architectures are possible, the first delivers the whole energy produced to the grid and the required energy for the TLC is taken from the grid itself. In the second one the photovoltaic generator supplies directly the TLC load and the surplus is sent to the grid through an inverter.

6.2.1 Off-grid connection system

An off-grid solution is realized with the following elements:

- 1) Photovoltaic modules: in order to reach the nominal power and voltage, the modules are connected in parallel and series.
- 2) Photovoltaic modules: in order to reach the nominal power and voltage, the modules are connected in parallel and series.
- 3) Charge regulator: used to control the correct charge of the batteries. This element stops the charge if the complete charge is achieved and prevents from the battery's deep discharge. Reverse current from PV to batteries is avoided with diodes.
- 4) Batteries: the correct amount of the battery capacity is the most important value in the system planning. This parameter depends on the average solar radiation, variations over day and season, and on the daily load profile.
- 5) Inverter: needed if AC power is required.

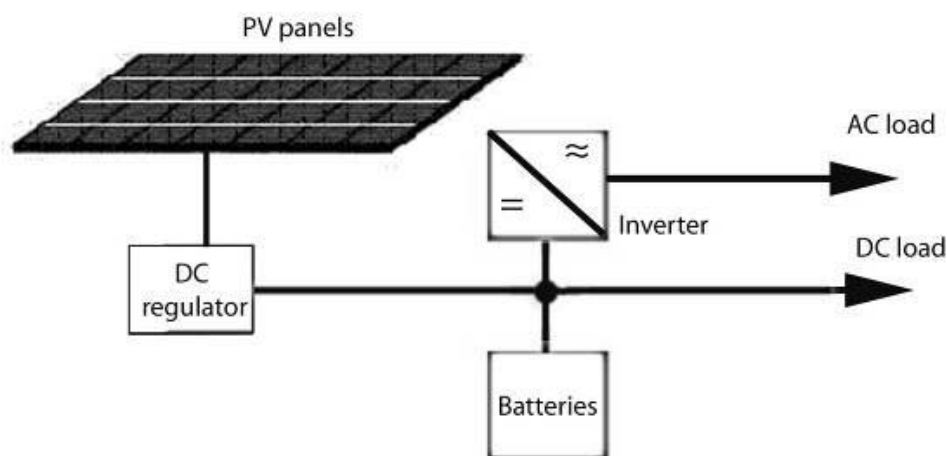

Figure 17: Off-grid photovoltaic power supply system

The AC and DC are supplied to the TLC load in accordance with ETS 300 132-1 [i.16] and EN 300 132-2 [i.17].

General sizing requirements and parameters

Off-grid sizing takes into account the mean power consumption of the load and the worst solar radiation (kWh/m²/d) on the site at the selected tilt angle. That has to allow to maximize energy performance in winter on a South orientation (for North latitude) and an angle equal to the latitude + 15° and not less than 70° in case of snow.

It is also necessary to take into account other parameters:

- albedo coefficient due to clear environment (snow, sand, etc), constant low temperature;
- error estimation on meteorological data;
- local geography and climate (shadows, masks due to mountains, fog, etc.);
- PV performance dispersion compared to nominal data;
- PV efficiency loss with ageing;
- effect of external temperature on junction temperature;
- battery efficiency of charge and effect of lower capacity for low temperature;
- charge voltage of the battery and effect on the reduction of output PV power.

Battery

The batteries are used to store energy for the needs during the night and the periods without sunshine to maintain system availability despite the unpredictable variations in weather. Types and characteristics are shown in EN 61427[i.18]. The sizing will take into account:

- the maximum period (h) without sunstroke;
- battery technology suitable for solar cycling and with a low self discharge;
- effect of low or high temperature on the capacity and ageing acceleration;
- daily depth of discharge;
- allowed total depth of discharge;
- loss of capacity with ageing.

Charge controller

The regulator or charge controller is the central component for energy management of the system and battery protection. It disconnects the load when the battery reaches a predetermined state of discharge and disconnect the battery from the photovoltaic array when the battery is fully charged taking into account possible variations with temperature, rate of charge or discharge, age of the battery.

The charge controller might be integrated with a Maximum Power Point Tracker (MPPT) function to get maximum energy from the solar array.

6.2.2 In-grid connection system

In grid connection system is shown in the following figure. The TLC load is powered by the usual AC/DC power supply system supplied by the grid. Batteries provide the back-up. Due to the continuous electrical energy "interchange" between the PV system and the grid, two different energy counters are required: one counts the energy given to the grid and the other the energy taken from the grid.

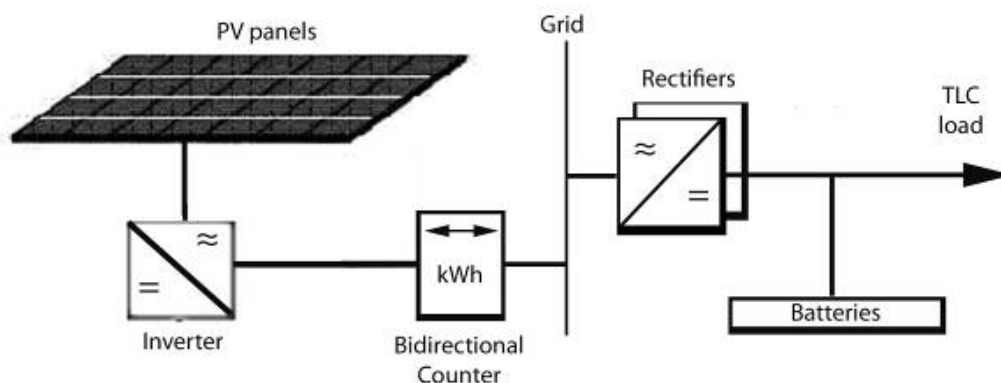

Figure 18: in-grid photovoltaic power supply system - case 1

In situations in which there is not any government contribution or the analysis highlights that there is not any economical convenience, the architecture becomes the one in the figure 19.

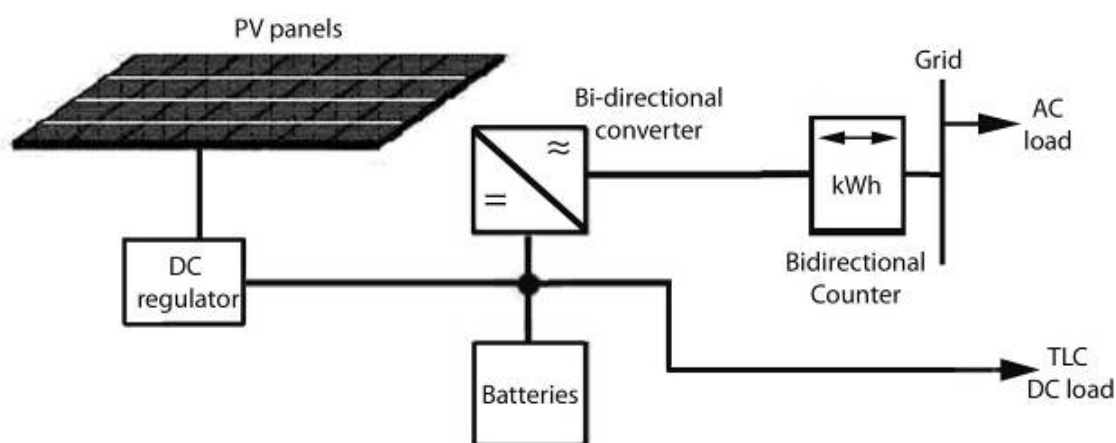

Figure 19: in-grid photovoltaic power supply system - case 2

The energy produced by the photovoltaic generator is used to supply the TLC load and to charge the batteries. The surplus energy produced is given to the grid through a bidirectional converter. In bad weather conditions or when the photovoltaic generator is not able to charge batteries, the bidirectional converter takes energy from the grid working in parallel with the photovoltaic system. The photovoltaic panels have to be decoupled from the bidirectional converter to prevent them to become a load. Also in this configuration a bidirectional counter is needed to measure the energy flux.

As described in figures 18 and 19, the main components are:

- Photovoltaic modules: in order to reach the nominal power and voltage, the modules are connected in parallel and series.
- Inverter: the solar energy is converted to AC power and sent to the grid; its nominal input voltage has a wide range to be compliant with the photovoltaic panels output voltage range.
- Bidirectional counter: measures the energy in both directions and permits to know the difference between the energy taken from the grid and the energy given to the grid.
- Power supply system: feeds the load with energy taken from the grid.
- Batteries: back-up the load during mains failure or no sunstroke.
- DC regulator: gives stable DC output to power the load and charge the batteries. It controls battery voltage and protect them from overcharge and deep discharge.

- Bidirectional converter: with photovoltaic energy present and battery full charged it behaves like an inverter giving power to the grid; when photovoltaic energy is not sufficient to power the load or the battery requires energy to be charged, it behaves like a rectifier powered by the grid.

One part of the produced energy also can be sold to the energy provider.

6.2.3. Planning of a PV system

In order to realize a correct planning of all the elements of a PV system, the variables are:

- 1) Geographical position (latitude).
- 2) Estimated solar radiation (max peak, daily profile).
- 3) Average temperature (this parameter influences the electrical efficiency).
- 4) Surface available for the installation.
- 5) Load peak and daily profile: this parameter is very important in case of off-grid installations, in order to determine the capacity of the batteries.

6.3 Wind energy systems

Wind generators can be very useful in remote sites, especially in mountain ones. The variation of the amount of wind - compared to the instantaneous power need - requires the use of an energy storage system to be able to power the TLC equipment even when the wind speed is too low.

The generating capacity of a wind generator system depends on the wind speed and is influenced by the generator's aerodynamics and its electrical efficiency.

The use of this kind of energy source is very suitable in radio link stations located in high mountain sites where there are favourable climatic conditions and there is a poor mains grid.

Depending on the type of load and of the generator, the structure of the system has to be based on some of the following elements: wind generator, rectifier, battery, inverter and load.

In the configuration of the following figure, the AC power from the wind generator supplies a rectifier that feeds both the batteries and the load. If the wind generator is not able to power the load (because of lack of wind or maintenance) the battery will do; obviously it has to be sized in a correct way. It is a good practise to oversize the battery to have a major support (without excessive cost). In any case it is important to have the historical wind data over a decade at least to be able to size the system.

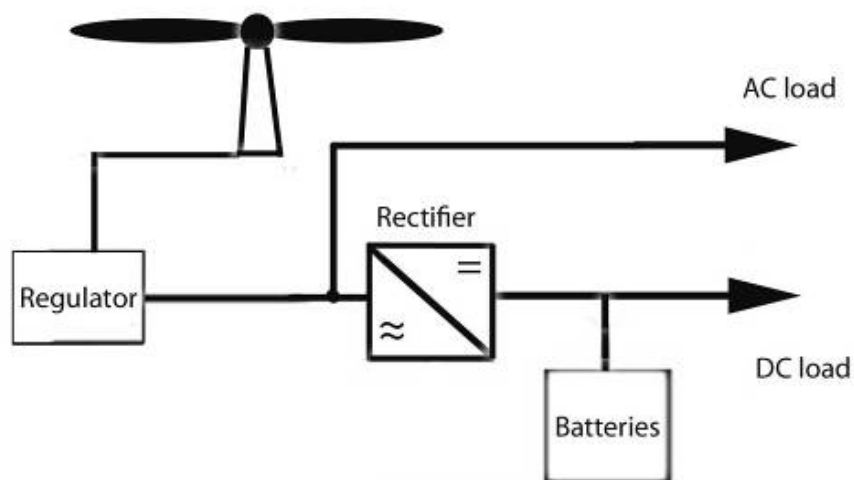

Figure 20: AC power wind energy power supply system

In the following architecture the wind generator supplies directly the TLC in DC; an inverter can be used to generate AC power. In the system there has to be a control logic that protects the battery from overcharge and deep discharge disconnecting it from the source or the load.

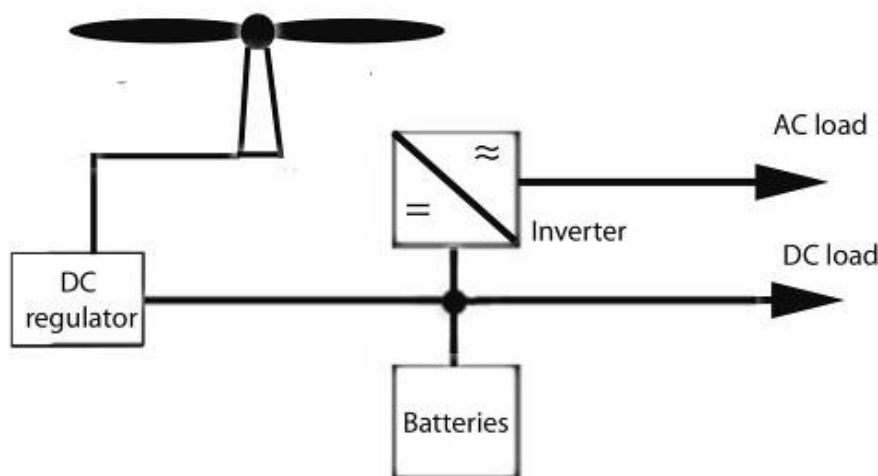

Figure 21: DC power wind energy power supply system

When designing a wind generator system, it is important to consider some parameters such as:

- available wind energy (yearly breakthrough): the energy of the wind goes with the cube of its speed. Each generator has a range of working speeds that it can support;
- wind characteristic of the site: the wind can vary a lot during the year on a specific site and its quantity can be estimated using statistical data;
- equivalent operating hours: the number of hours in a year that the generator should have worked at nominal capacity to provide the energy actually supplied.

6.3.1 System design

To design a wind generator system, the first step is to know the hourly distribution of the wind speed over the year, the second is to choose the generator according to these site characteristics.

The historical data are taken from meteorological stations, balloons and aircrafts considering a typical height of 10 m to 70 m. The values show the mean speed $\langle v \rangle$ of the wind so it is necessary to go from speed to power and hence to find the relationship between $\langle v \rangle^3$ and $\langle v^3 \rangle$. There are simple models (used both in U.S. wind atlas and in the European one) that consider these two quantities simply proportional; following them the relation between speed and power can be written as:

$$P_w = 0,625 \langle v^3 \rangle \approx 1,3 \langle v \rangle^3 \frac{W}{m^2}$$

To go from the power in the wind to the power that can be generated by the turbine, it is necessary to take into account its non linear response. Current turbines usually start to produce at ≤ 3 m/s until a maximum of ≥ 12 m/s.

6.3.2 Installation

The wind generator has to be installed on a tower at a height suitable for the location, according to the topography of the site and to the surrounding objects that can create turbulences.

The reliability of such a system is important especially when used in remote sites; this is guaranteed through the following features:

- Corrosion protection.
- Over speed protection.
- Lightning protection.
- Low maintenance requirements.
- High MTBF.

6.4 Hydropower systems

To determine the hydro potential of water flowing from the river or stream, it is needed to know the flow rate of the water and the head through which the water can fall, as defined in the following:

- the flow rate is the quantity of water flowing past a point at a given time. Typical unit used for flow rate is cubic metres per second (m^3/s);
- the head is the vertical height in metres (m) from the level where the water enters the intake pipe to the level where the water leaves the turbine.

It is important to note that there is a head and a flow rate below which there is no economic advantage in obtaining electrical power. These minimum heads and flow rates are difficult to specify because a combination of high values of one with low values of the other can give some useful power.

The principle scheme to be adopted in a TLC power plant is the one below.

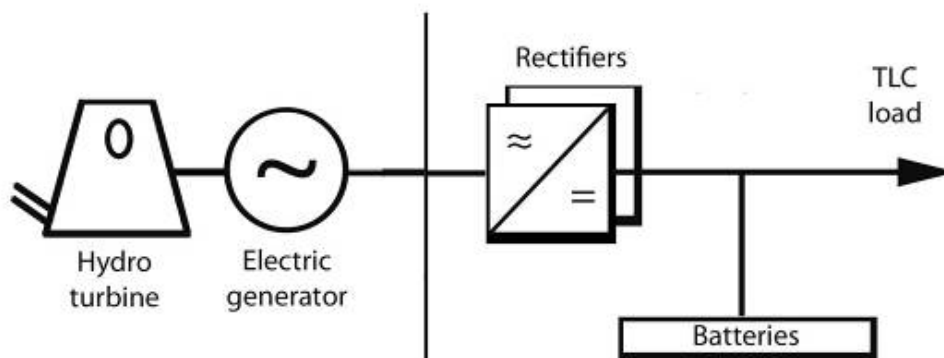

Figure 22: Hydropower supply system

In plants of the size suitable for telecommunication sites, the types of turbine used are mainly: cross flow, Pelton and Francis.

The generator is packed together with the control unit in a single package easy to transport and to install. Such a system needs almost no maintenance, in continuous operation it needs lubrication once a year.

7 Hybrid systems

In some cases it is a good solution to combine alternative and conventional solutions creating an hybrid system that, when integrated, overcome limitations inherent in either.

Incorporating heat, power, and highly-efficient devices can increase overall efficiency and conserve energy for a hybrid system when compared with single generator technologies.

Achieving higher reliability can be accomplished with redundant technologies and/or energy storage. Some hybrid systems typically include both, which can simultaneously improve the quality and availability of power.

Hybrid systems can be designed to maximize the use of renewable fuels, resulting in a system with lower emissions than conventional fossil-fuelled technologies, and to achieve desired attributes at the lowest acceptable cost.

7.1 System design

When designing a hybrid system, there are four main components to be sized: the renewable energy generator (i.e. source and converter), the fuel generator, a controller and a storage system (e.g. battery).

The guidelines to be followed are mainly these:

- the renewable energy source has to be able to provide the required power to the load and charge the battery under the site's average meteorological conditions;
- the fuel generator is dimensioned to have the capacity to supply the load and recharge the battery (without oversizing). Another important element is to choose a generator which rated output is very close to the one required by the load to avoid problems due to a light loaded generator. This is an element to consider also for some types of fuel cells;
- the battery has to be charged by both the sources;
- the sizing of the renewable source has to take into account also the statistics of the meteorological data considering the costs, too;
- the battery has to operate between the renewable energy source and the fuel generator: when the first is not able to power the load, the battery starts operating and, when it is discharged, the fuel generator starts;
- the controller is responsible for the energy management and the control of the different elements. It may act also as central fault management and communication entity for the complete system.

An important aspect is the control strategy used for batteries, it has consequences on the reliability, efficiency and low maintenance of the system. The main tasks are:

- to monitor the state of charge and to start the fuel generator when it reaches the minimum safe level, in this way it is possible to protect the battery against deep discharge and to use the fuel generator as less as possible;
- to avoid overcharging;
- to protect against overvoltage.

The monitoring unit operates with four main thresholds to classify the state of the battery: partial discharge, discharge until a minimum set-point, charge to near full capacity (e.g. 90 %) and full charge.

To be sure that the battery does not continue to feed the load when the low charge threshold is reached a Low Voltage Battery Disconnect (LVBD) has to be installed.

One of the main characteristics of the fuel generator is its starting reliability and time. For fuel cells, it has to be considered that the time they require to reach the stationary conditions can be much longer than the time required by a diesel engine. Usually the reliability target is to have no more than one hour lost in ten years for starting issues.

Since it can happen that, thanks to the availability of the renewable energy sources, the fuel generator stays inactive for long periods, it is necessary to perform periodical test starts to be sure that it is efficient and ready to start in case of need. This strategy is aimed to keep the maintenance as low as possible.

Figure 23 summarizes the different possible solutions available to realize hybrid system.

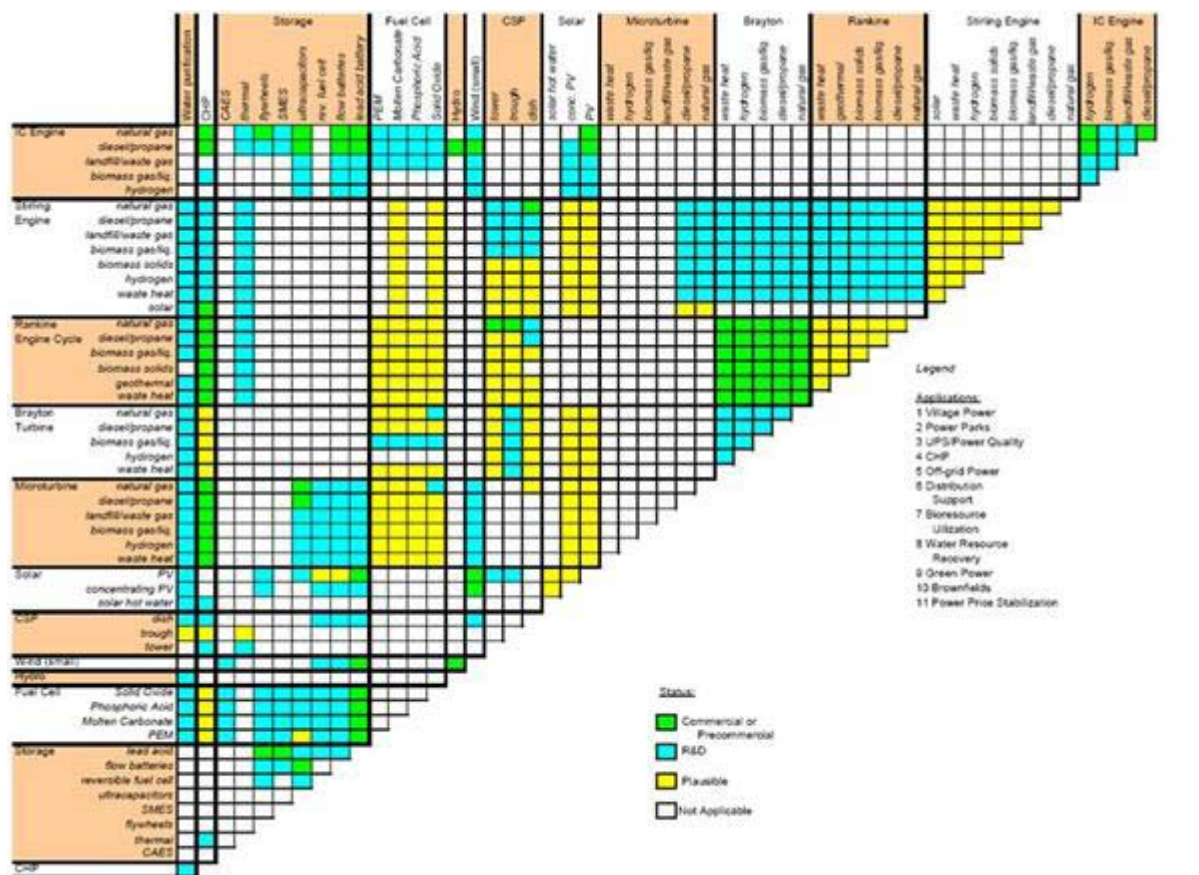

Figure 23: Hybrid systems matrix

NOTE: Data from U.S. DOE Natural Gas / Renewable Energy Workshops August 21, 2001 Golden, Colorado.

In telecommunication applications the most used are described in clause 7.3.

Since the main load, especially in Telecom applications of mobile operators, is of DC type, the two designs of figure 24 are preferable from technical perspective:

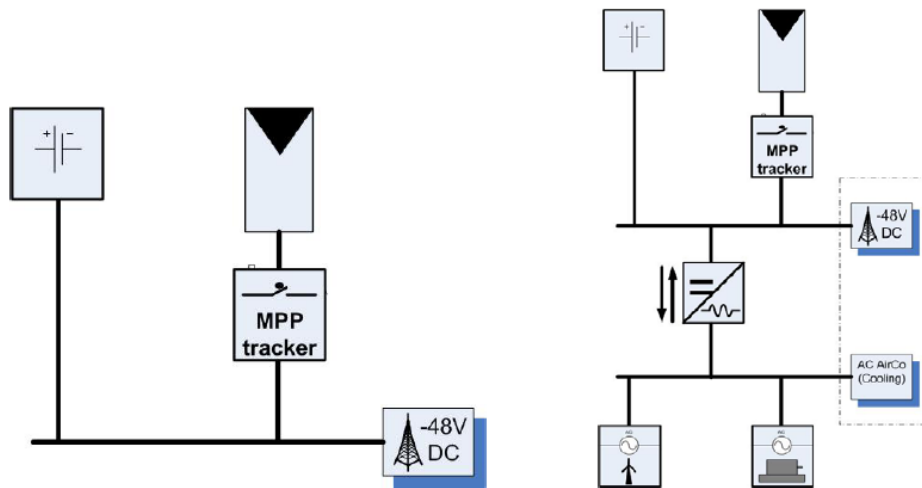

Figure 24: Pure DC and mixed AC/DC technical design of a Hybrid system

The solar battery charger might be equipped with a "Maximum Power Point Tracking" (MPPT) feature. The Inverter in the mixed design is a bidirectional one, possible to transform energy from the DC bus to the AC side and vice versa.

7.2 Planning of a Hybrid system

A possible approach to distinct the different phases during the set-up of a Hybrid site are to distinguish several phases. It should be noted that financial aspects should always be considered in parallel, because of the high initial investments and the considered longer payback period compared to conventional power solutions like, diesel generator, etc.

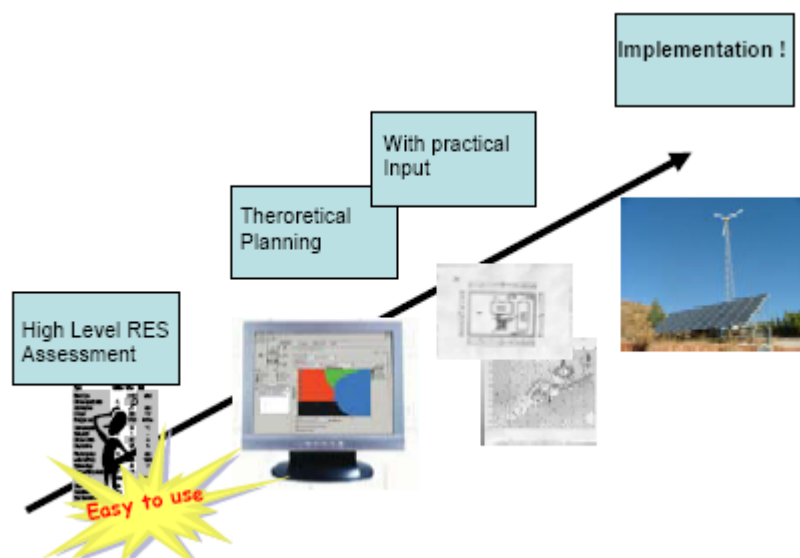

Figure 25: Possible planning approach

The first phase covers the first evaluation to select Hybrid site candidates. This phase should contain a first high level technical design and economic assessment of the renewable energy solution. It is recommended to keep this phase in-house.

The planning phase is a task where the specific detailed planning takes place. For this specific planning tools can be used (e.g. HOMER, RETSCREEN) to get to evaluate the most efficient technical design. This phase is sometimes in-house or outsourced.

Finally the implementation phase kick-off the operational period. However, maintenance aspects, e.g. for WTG, should be considered from the beginning.

7.3 Selected Hybrid systems

7.3.1 Wind turbine generator combined with fuel consuming generator

In power system designing for a remote site the choice of a wind generator may be appropriate considering the climatic data of the location. In the beginning phase four parameters have to be considered:

- Power needed by the load.
- Economical planning and operation costs.
- Available space and site accessibility.
- Possibility for expansion.

The presence of the fuel generator allows to optimize the size of both the wind generator and the battery, reducing installation and running costs. Regular maintenance of the wind generator can be assumed to be on an annual basis.

The architecture of a hybrid system is shown in figure 26:

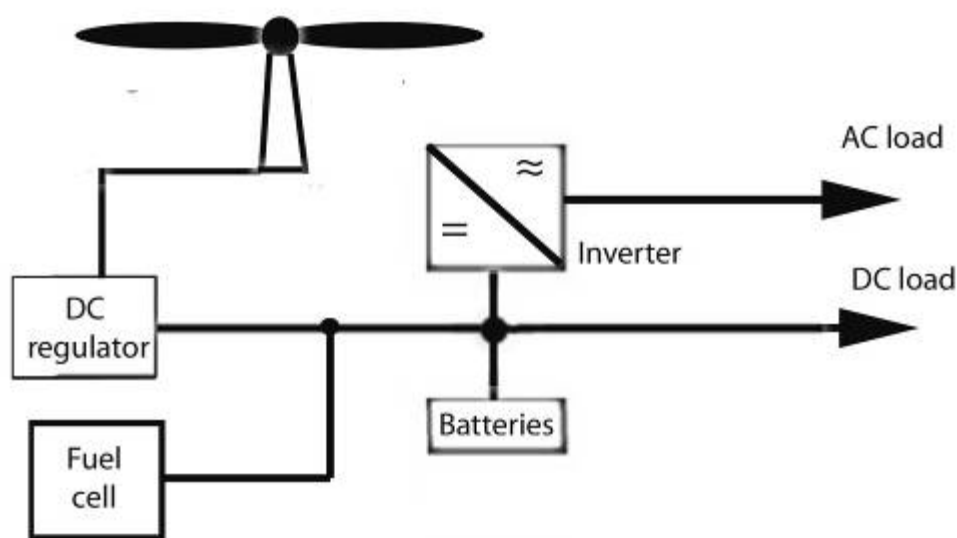

Figure 26: Wind generator combined with fuel generator in the pictures cube with fuel cell has to be replaced with fuel generator

When the wind energy has a suitable intensity, the wind generator powers the load and charges the battery; when it is below the required level the battery gives the missing power. If this condition persists and the battery reaches the minimum SOC, the fuel generator starts feeding the load (and, eventually, charging the battery).

To be able to better manage batteries (for maintenance or replacement) it is good to divide the total battery equipment into two half capacity banks.

Controllers

To manage correctly the battery it is needed to install a control unit that regulates the charge and monitors the state of charge.

It is important to provide an alarm signalling and transmission system that controls both the generators and the subsystems alarms.

Sizing

During the sizing phase of the design, the elements to define are: the size of the wind generator and of the batteries, the size and type of the fuel generator and its quote of energy to provide over the total amount required.

The data from which to start are the following:

- Meteorological and geographical data related to the wind potential.
- Load.
- MTTR.
- System availability.
- Number of starts of the fuel generator.
- Costs (including fuel consumption and its transportation to the site).

Generally the wind generator is sized at a ratio that ranges from 3:1 to 8:1 respect of the required power, while the fuel generator is sized in a way that it is able to power the load and charge the batteries.

Examples

Hereafter there is an example of sizing for a system with the following assumptions:

- Annual average wind speed of 5 m/s described by a typical Weibull distribution.
- Fuel consumption for 1 kWh is 0,3 kg of fuel.
- Number of annual start-ups of the generator is:

$$n_s = \frac{365 \cdot x}{T_R + B}$$

where x is the percentage of the energy supplied by the fuel generator, B is the battery duration in days and T_R is the recharge time in days.

For an 800 W load with 5 days reserve and 30 % energy from the fuel generator with an annual average wind speed of 5 m/s the result is:

- Wind generator power: 3 kW at 9 m/s.
- Battery capacity: 2,5 Ah at 48 V.
- Fuel generator power: 15 kVA.
- Yearly fuel consumption: 1 800 l.
- Start-ups in a year: 20.
- FG service intervention per year: 1.
- WG service intervention per year: 1.

7.3.2 Photovoltaic generator combined with fuel consuming generator

The choice of a photovoltaic generator has some advantages due to high reliability and low maintenance need; the major disadvantage is the high initial cost with substantial interest rate and depreciation costs over the economic life-time.

On the other hand a fuel generator (fuel cell or combustion) is less reliable, requires refuelling and highest maintenance. A good compromise is to combine the two types to obtain improvements about costs, reliability and sizing.

The system architecture is shown in figures 27 and 28 with fuel cell.

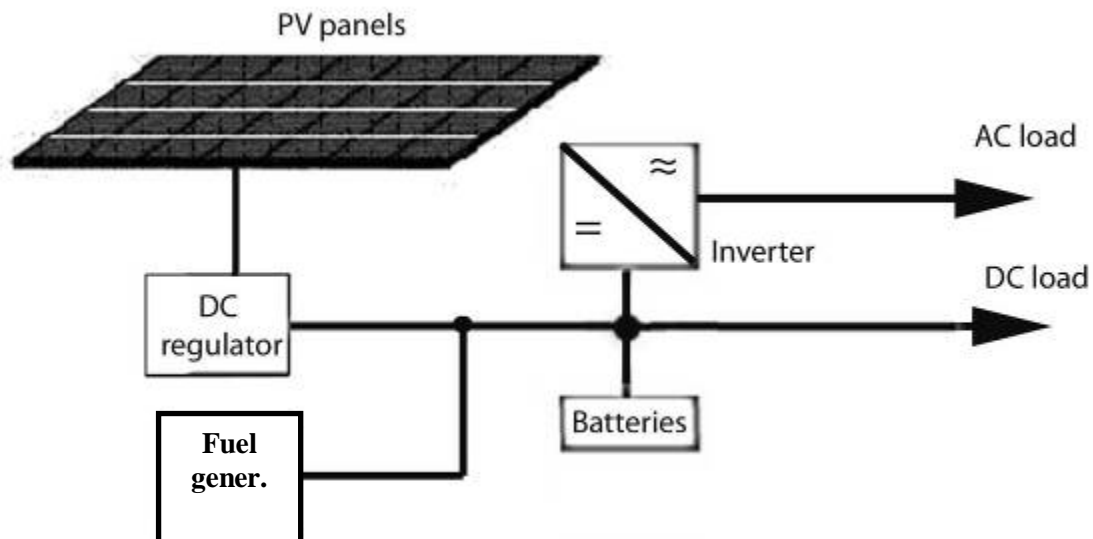

Figure 27: Photovoltaic generator combined with fuel generator

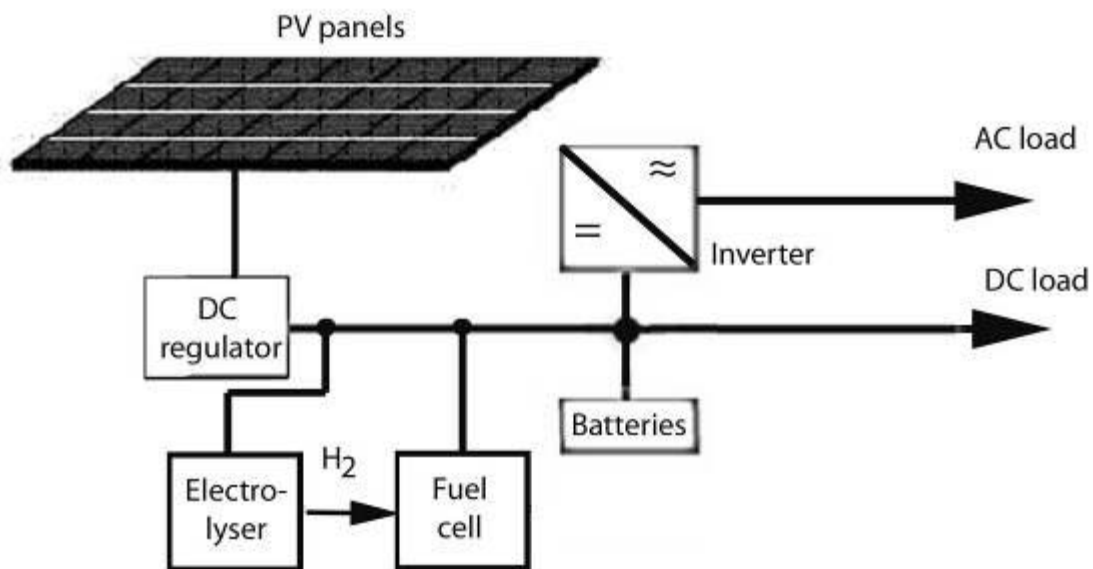

Figure 28: Photovoltaic generator combined with fuel generator (FC with electrolyser)

This approach could lead to a close energy generating system avoiding hydrogen logistic.

For the case of photovoltaic generator combined with fuel cell generator using H₂ produced by an electrolyser, an H₂ compressor and tank are generally used, in order to reduce the size of the H₂ tubes needed for adequate energy storage, as the pressure from the electrolyser is low.

When the solar radiation has the proper intensity the photovoltaic generator provides power to the load and charges the battery; in this situation the fuel generator is in stand-by status. When solar radiation is below a certain level or during night the battery powers the load.

In bad weather conditions and when the SOC of the battery is low, the fuel generator starts powering the load and charging the battery.

The control unit has to provide some important functionalities, such as: overvoltage and deep discharge battery protection, state of charge monitoring to be able to start the fuel generator in time even in case of fail during start-up, collection and transmission of alarms.

About installation the photovoltaic generator has to be installed following the normal criteria used regarding inclination, orientation and shadows awareness. There is a further element related to the fuel generator: if it is a diesel engine the modules have to be installed far away from the exhaust to avoid particles to lay down on the photovoltaic panels.

The fuel tank has to have a capacity suitable to power the load during the time in which the other source is not available. If using fuel cells, particular attention has to be put in the choice and location of the hydrogen tank. It is possible also to produce the hydrogen on site through electrolysis of water, in this case a water tank has to be provided, and a H₂ compressor and gas tank, for adequate H₂ energy storage.

Very important is the lightning protection that can be achieved connecting the system to the earth network through conductors with a cross section of at least 50 mm².

Maintenance

Periodical inspection of the system is needed to assure efficient operation. Photovoltaic generator does not require big operations, the only activities are the cleaning of the module's surface and the visual check for damages (such as glass cracks, opacity, delamination, etc.).

About the fuel generator, if it is a diesel engine the checks regard oil and liquids levels, filters cleaning and starter battery state check; if it is a fuel cell it does not require any special check but the membrane needs to be changed out on a regular basis, estimated every five years, though there is no practical experience yet.

7.3.3 Photovoltaic generator combined with wind generator and fuel consuming generator

Since photovoltaic, wind and fuel generator have each one its own advantages and disadvantages their combination allows to use their complementary characteristics to obtain an efficient system.

In some conditions wind and sun are complementary so it is possible to extend the operating range of the renewable energy generation and, thus, to employ generators with a lower peak power. The possibility that the wind and photovoltaic generator can work in parallel makes the fuel generator to work in a limited time.

The structure of such a system is shown in figure 29.

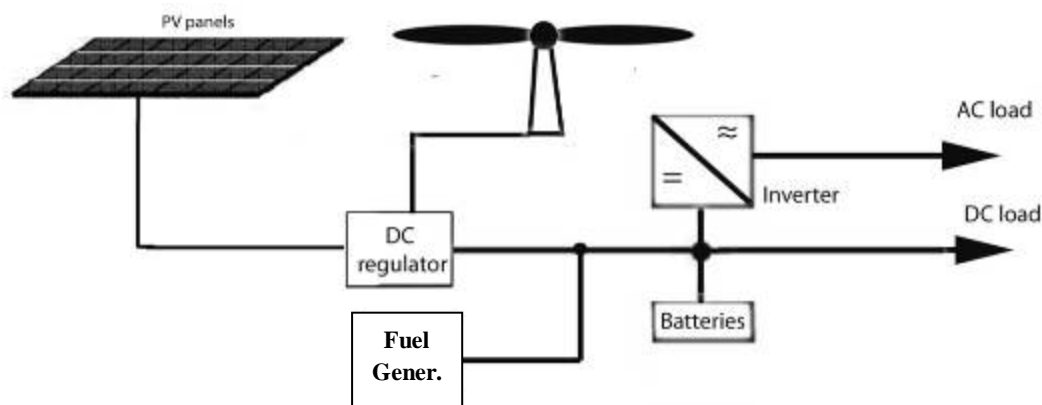

Figure 29: Photovoltaic generator combined with wind and fuel generator

In normal conditions the load is powered by the photovoltaic and wind generators using battery if the level is not sufficient. In case of an excess of energy this will charge the battery. In situations of low sun and wind and with a low battery SOC, the fuel generator will start; its contribute will be between 5 % and 30 % of the yearly total. Due to the intermittent operation requested in this architecture, the fuel generator has to be able to start and stop often in an reliable way.

It is necessary to avoid a state of deep discharge (below 50 %) of the battery for a long period in order to prevent degradation (e.g. sulphation). For this reason in the moments in which the renewable energy sources are not able to give the required power, the load will be fed from the battery and in case of low state of charge the fuel generator has to start feeding the load and charging the battery.

Sizing

When designing the system, the main aspects to consider are:

- The balance between the photovoltaic generator and the wind one.
- The percentage of energy provided by the fuel generator.
- Battery capacity.
- Meteorological data of the site.
- Reliability needed for the application.

To define the proportions between photovoltaic and wind generators, the wind generator has to be considered first because usually wind turbines are available in a certain number of sizes in opposition to photovoltaic modules which are produced in sizes that allow better modularity.

In this solution if the fuel generator work load is kept under 30 % the investment and operation costs will be balanced.

Example

The system in this example is supposed to be in a site at 60° latitude and with a mean wind speed of 6,7 m/s with a load of 450 W. The photovoltaic panels are installed with a tilt angle that maximizes the summer production since in that period the wind is lower than in winter. The fuel generator is a diesel engine that has to provide 5 % of the total power. The equipment will be the following:

- Wind generator: 900 WP at 11 m/s.
- Photovoltaic generator: 1 500 WP.
- Storage battery: 1 100 Ah, 48 V, 5 days.
- Fuel generator: 3 kW.
- Yearly fuel consumption: 0,2 m³.
- Yearly start-ups: 8.
- Yearly maintenance visits: 1.

Existing systems combining by diesel generator and batteries working in cyclic mode can be upgraded to an hybrid system such as the one present in this clause.

8 Cooling systems

8.1 Geo-cooling

In geology, "geothermal" identifies the heat sources within the Earth. In particular, temperature within the Earth increases with increasing depth. Highly viscous or partially molten rock at temperatures between 650 °C and 1 200 °C is postulated to exist everywhere beneath the Earth's surface at depths of 80 km to 100 km, and the temperature at the Earth's centre, nearly 6 400 km deep, is estimated to be around 7 000 °C, as visible in figure 30.

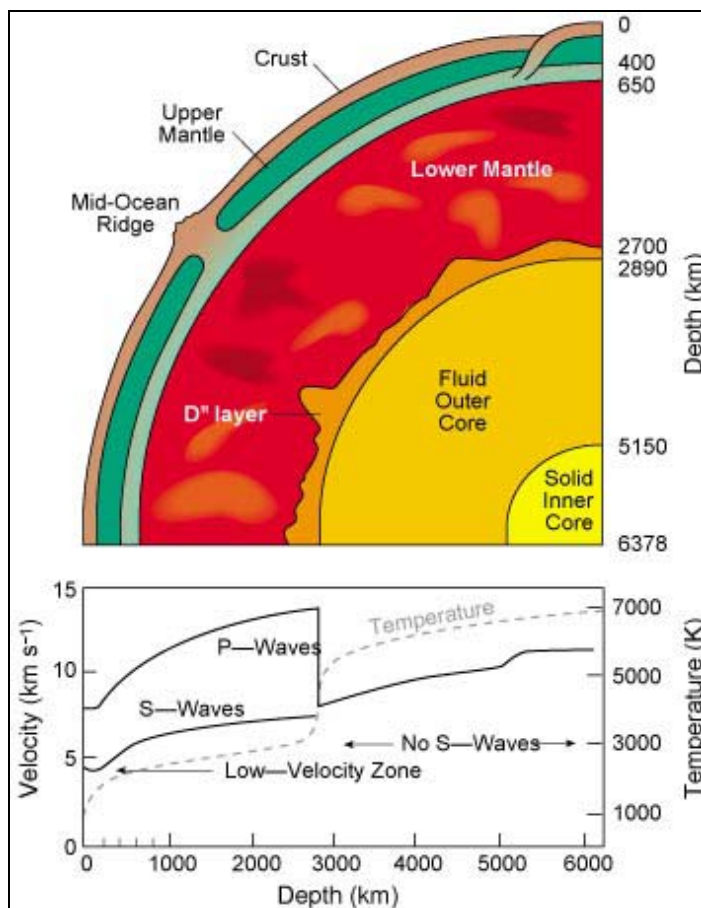
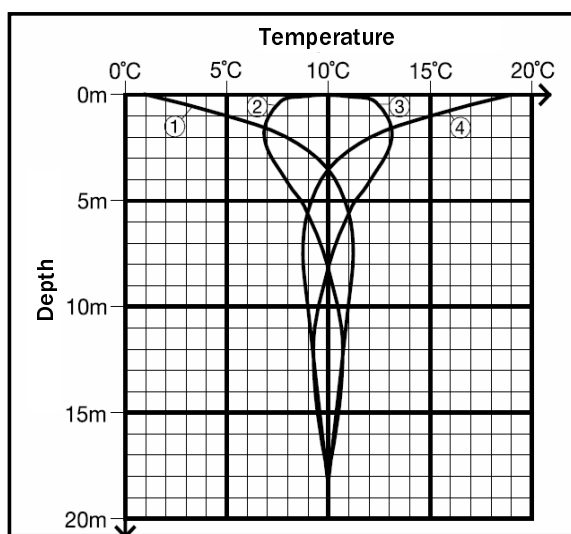

Figure 30: Temperature within the earth vs. depth

Much of the heat is believed to be created by decay of naturally radioactive elements. An estimated 45 to 90 percent of the heat escaping from the Earth originates from radioactive decay of elements within the mantle. Heat flows constantly from its sources within the Earth to the surface. Global terrestrial heat flow is about 45 TW (1 TW = 1 012 W).

Concerning limited depths, as shown in the following figure, a constant temperature of about 10 °C is measured at a depth of 20 m: then, the temperature grows approximately by 3 °C every 100 m.



1: 1st February – 2: 1st May – 3: 1st November – 4: 1st August

Figure 31: Temperature within the earth vs. limited depth

As shown in figure 32, there are different solutions that can draw advantage from the ground source energy (that, at low depth, has mainly a solar origin, while at relevant depth has a geothermal origin). In particular, it can be exploited through:

- groundwater;
- vertical probes;
- horizontal collectors;
- ground to air heat exchanger.

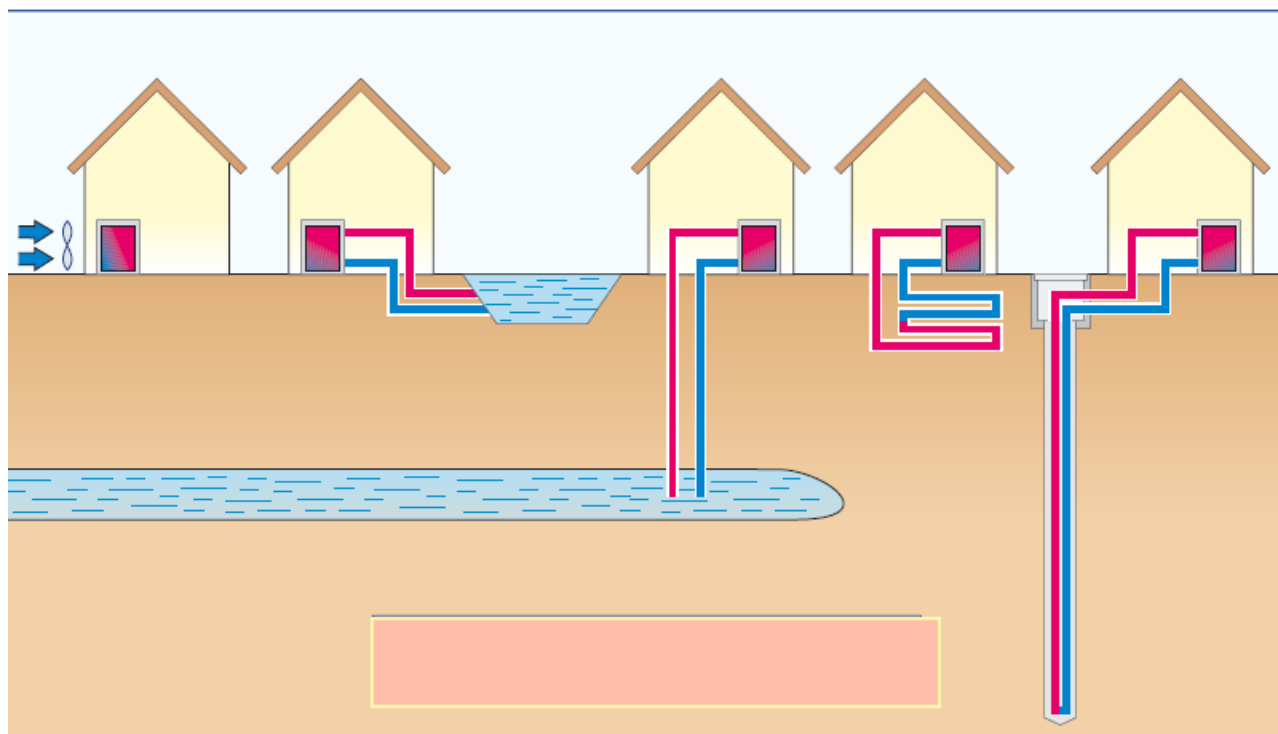

Figure 32: Different solutions for use of ground energy source

Furthermore, several geothermal solutions include the adoption of heat pumps (see figure 33), that can move heat from one location (the "source") to another location (the "sink" or "heat sink"). One common type of heat pump works by exploiting the physical properties of an evaporating and condensing fluid known as a refrigerant. The working fluid, in its gaseous state, is pressurized and circulated through the system by a compressor. On the discharge side of the compressor, the now hot and highly pressurized gas is cooled in a heat exchanger called a condenser until it condenses into a high pressure, moderate temperature liquid. The condensed refrigerant then passes through a pressure-lowering device like an expansion valve, capillary tube, or possibly a work-extracting device such as a turbine. This device then passes the low pressure, barely liquid (saturated vapour) refrigerant to another heat exchanger, the evaporator where the refrigerant evaporates into a gas via heat absorption. The refrigerant then returns to the compressor and the cycle is repeated.

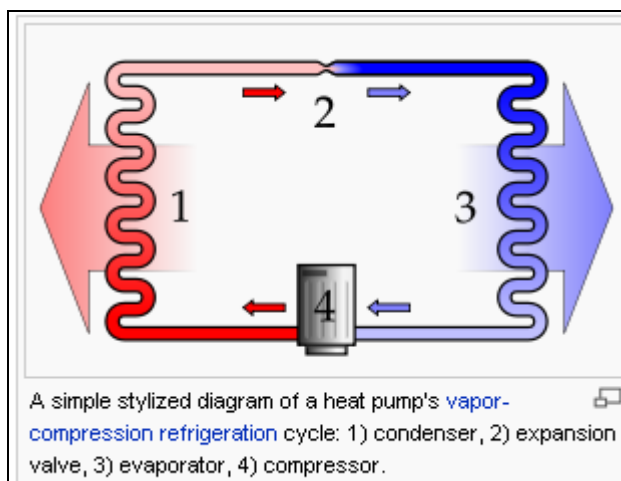

Figure 33: Heat-pump scheme

If the cycle is inverted, the heat pump acts as a refrigerator machine: in this way, geothermal heat can be used for heating in winter, and for cooling in summer. In the following, are reported some in-depth examinations concerning the main geothermal solutions.

8.1.1 Horizontal collectors

The geothermal plants that use horizontal collectors (placed at a depth of 0,8 m to 2 m, see figure 34) are:

- ideal when large area available;
- highly efficient;
- easy and inexpensive to install (no specialist bore hole drilling required).

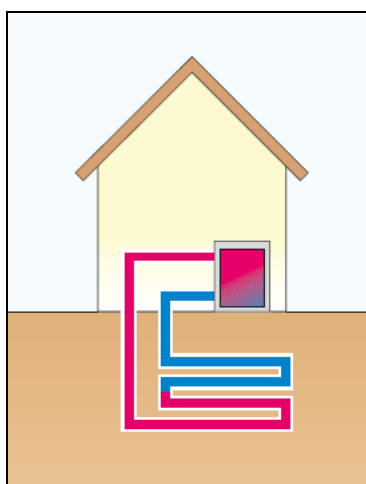

Figure 34: Geothermal plants that use horizontal collectors

Table 7 gives an idea of the thermal power that can be extracted using horizontal collectors.

Table 7: extraction of thermal power with horizontal collectors

Type of ground	Area dissipation [W/m ²]	Collector dissipation [W/m]
Dry and sandy	10 to 15	4 to 6
Humid and sandy	15 to 20	6 to 8
Dry and clayey	20 to 25	8 to 10
Humid and clayey	25 to 30	10 to 12
Water saturated	30 to 40	12 to 16

8.1.2 Vertical probes

The geothermal plants that use vertical probes (placed at a depth of 10 m to 200 m, see figure 35) are:

- ideal when no large area is available and/or there is a huge load to dissipate;
- low-maintenance requiring.

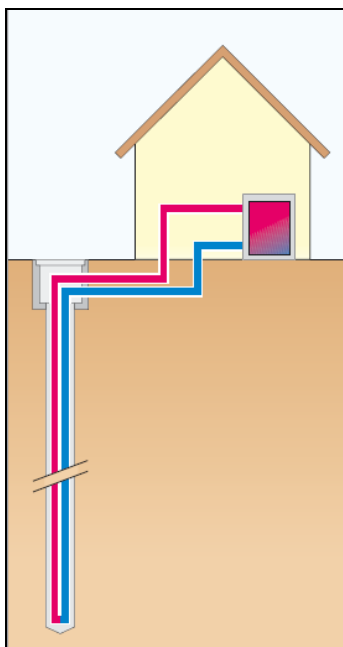

Figure 35: Geothermal plants that use vertical collectors

Table 8 gives an idea of the thermal power that can be extracted using vertical probes.

Table 8: extraction of thermal power with vertical collectors

Type of ground	Probe dissipation [W/m]
Dry sand/gravel	< 20
Dry sediments	20
Rock or humid soil	50
Rock with high conductivity	70
Water saturated sand/gravel	55 to 65
Humid clay	30 to 40
Chalky rock	45 to 60
Sandstone	55 to 65
Granite	55 to 70

8.1.3 Ground-to-air heat exchanger

The geothermal plants that use ground-to-air heat exchanger (see figure 36) conduct fresh air through an underground pipe system to heat it in winter and to cool it in summer. This solution is mainly used for residential buildings, where the load to dissipate is quite limited.

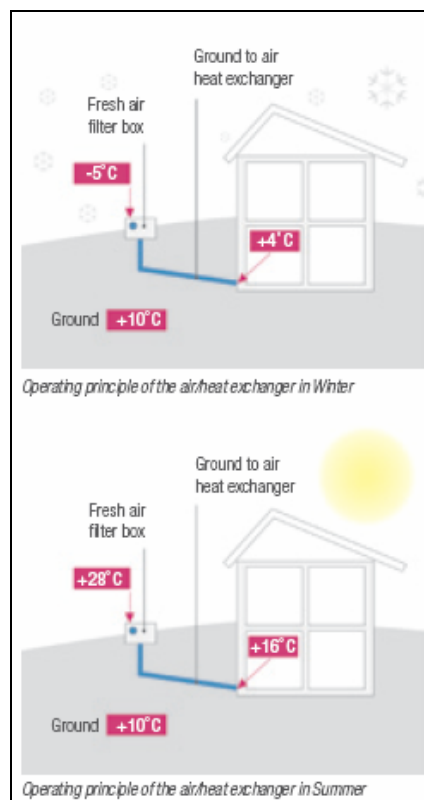

Figure 36: Geothermal plants that use vertical collectors

The specific situation of a TLC (fixed or mobile) site or a Data Centre suggests the adoption of the Geo-cooling option only, considering that the equipment rooms have a high temperature (24 °C and above) in every period of the year. To this end, depending on:

- the specific total amount of the load;
- the geographical reference area;
- the available space around the site.

Every solution described in the previous pages can be adopted. The only significant change concerns the heat pump, which can be avoided in order to reduce payback time of the investment, considering that (unless there are offices located near the equipment rooms) the functionality of heating during the winter is not needed.

8.2 Free cooling

Free cooling (or fresh air cooling) takes place when the external ambient air enthalpy (the term used for a combination of sensible heat and moisture content) is less than the indoor air enthalpy and the cool external air is transferred to the building envelope either directly or indirectly. The implementation of free cooling in TLC or Data Centre sites allows strong reduction of the total number of hours during which the air conditioners are used.

Fresh air cooling throughout year

Depending on climatic conditions the use of outside air throughout year i.e. 100 % of the year for cooling equipment is practicable (TOTAL fresh air cooling).

No refrigerative units are needed. Different options for implementation of fresh air cooling are possible. By hot spot exhaust solution, warm air is directly collected above the cabinets over air ducts and removed outside of the building over exhaust fans (see figure 37). Outside air is supplied through apertures in the outdoor facade or over air ducts if no direct access is available.

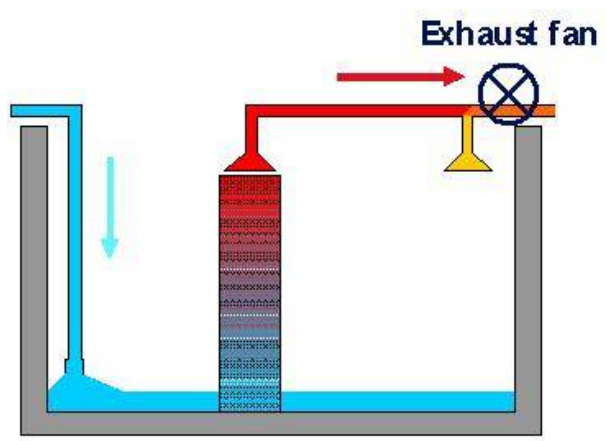

Figure 37: Scheme of total fresh air cooling solution with hot spot exhaust

Air managing in the TLC/ICT rooms

There are basically three main methods for the air inlet within a room:

- "Over" or "Up flow" (see figure 38): the fresh air is distributed from the top side of the room, while the warmed up air is recovered from the bottom (as visible in figure 38). Certainly this is not the most efficient method for air inlet, considering that this solution allows the creation of "stagnation" areas, and if there are heat sources within these areas, it becomes really probable to obtain "hot points" that could lead to equipment damages.

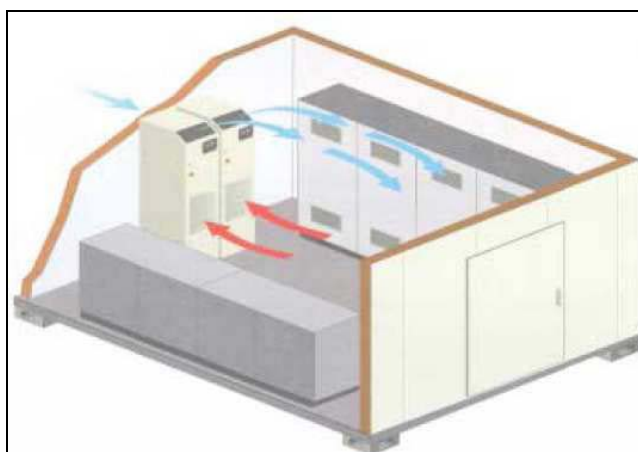

Figure 38: "Over" or "Up flow" air distribution

- "Under" or "Down flow" (see figure 39): the fresh air is distributed from a raised floor, through appropriate grids. This is a more efficient solution with respect to the "Up flow", even if the air flow is the same for all the equipment, while it should be greater where the load is higher. The main problem of this solution is that it's not always possible to realize a raised floor in an existing room (nor is it possible to shut down the TLC equipment or server to allow the civil works).

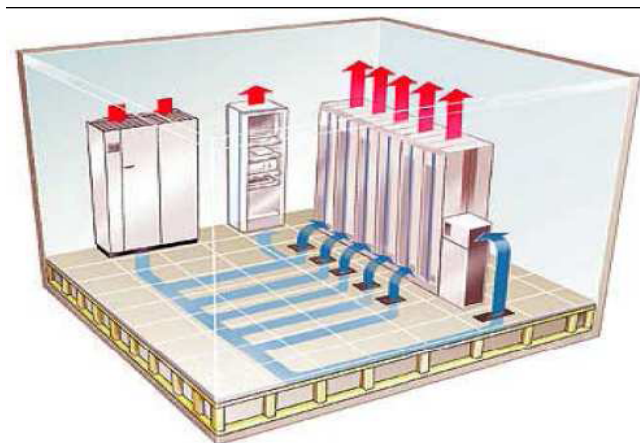

Figure 39: "Under" or "Down flow" air distribution

- "Displacement" (see figure 40): the fresh air flow is distributed at a low speed at the floor level, without the need for raised floor. Moreover, the low air speed allows the creation of a low temperature air layer (with a low turbulence) that reaches the different equipment. The most important benefit is that with this solution, the fresh air capacity is absolutely proportional to the thermal load to dissipate.

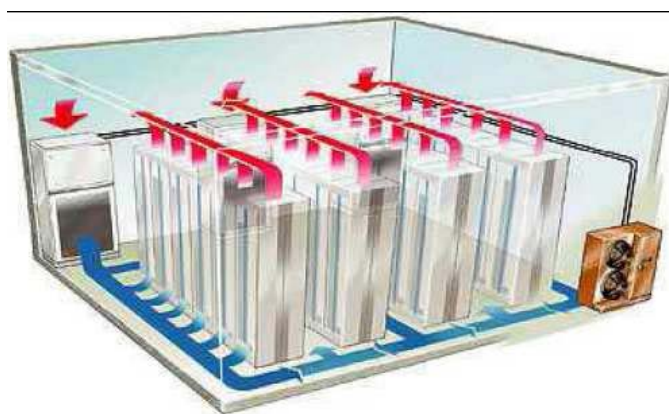

Figure 40: "Displacement" air distribution

The overall benefits of the free cooling adoption obviously depend on several factors: the average external temperature, the amount of total load placed within the room, the method used for the air inlet, etc. Anyway, a situation where the fresh air is used for approximately 70 % to 80 % of the year can be quite easily reached. To this end, the rise of the average temperature allowed within the equipment room can surely help to reach (and probably outperform) the above percentages.

8.3 Absorption machines

In order to get advantage of the heat dissipation from equipment for cooling purposes, absorption cooling systems can be used; these system are currently tested in telecommunication area.

Figure 41 gives an idea of the working principle:

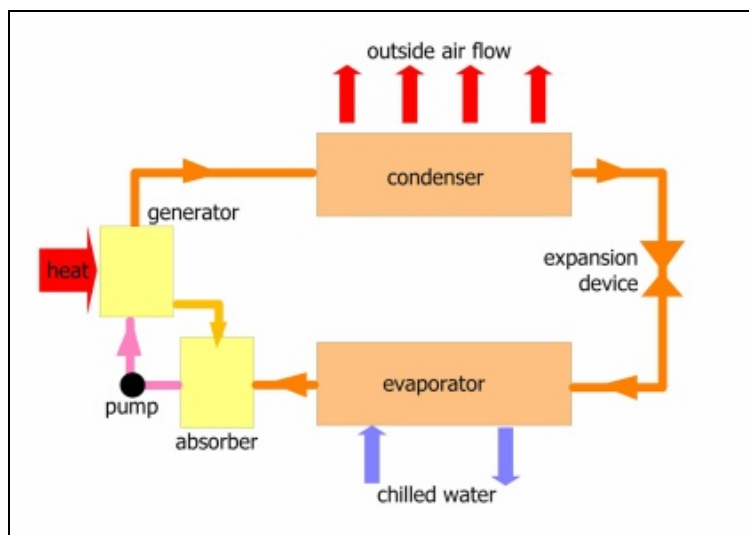

Figure 41: Example of absorption cooling cycle

Annex A: Bibliography

- ETSI EN 300 132-3: "Environmental Engineering (EE); Power supply interface at the input to telecommunications equipment; Part 3: Operated by rectified current source, alternating current source or direct current source up to 400 V".
- ETSI EN 302 099: "Environmental Engineering (EE); Powering of equipment in access network".
- ETSI EN 300 253: "Environmental Engineering (EE); Earthing and bonding of telecommunication equipment in telecommunication centres".
- CENELEC EN 61400-1: "Wind turbine generator systems – Part1: Safety requirements".
- CENELEC EN 61400-2: "Wind turbine generator systems. Safety of small wind turbines".
- CENELEC EN 61400-11: "Wind generator system noise measurement method".
- CENELEC EN 45510-5-3: "Guide for the procurement of power station equipment. Wind turbines".
- CENELEC EN 61400-12: "Wind turbine generator systems. Wind turbine power performance testing".
- CENELEC EN 61400-21: "Wind turbine generator systems. Measurement and assessment of power quality characteristics of grid connected wind turbines".
- CENELEC EN 50308: "Wind turbines. Protective measures. Requirements for design, operation and maintenance".
- CENELEC EN 62124: "Photovoltaic (PV) stand-alone systems. Design verification".
- CENELEC EN 61173: "Overvoltage protection for photovoltaic (PV) power generating systems – Guide".
- CENELEC EN 61727: "Photovoltaic (PV) systems – Characteristics of the utility interface".
- CENELEC EN 50380: "Datasheet and nameplate information for photovoltaic modules".
- CENELEC EN 61721: "Susceptibility of a photovoltaic (PV) module to accidental impact damage".
- CENELEC EN 61724: "Photovoltaic system performance monitoring – Guidelines for measurements, data exchange and analysis".
- CENELEC EN 61277: "Terrestrial photovoltaic (PV) power generating systems – General and guide".
- U.S. DOE Natural Gas / Renewable Energy Workshops August 21, 2001 Golden, Colorado:
<http://www.netl.doe.gov/publications/proceedings/01/hybrids/>.

History

Document history		
V1.1.1	June 2009	Publication