

ETSI TR 102 489 V1.2.1 (2010-02)

Technical Report

Environmental Engineering (EE);
European telecommunications standard for equipment practice;
Thermal Management Guidance for equipment and its deployment



Reference

RTR/EE-00011

Keywordsenvironment, equipment practice, management,
rack**ETSI**

650 Route des Lucioles
F-06921 Sophia Antipolis Cedex - FRANCE

Tel.: +33 4 92 94 42 00 Fax: +33 4 93 65 47 16

Siret N° 348 623 562 00017 - NAF 742 C
Association à but non lucratif enregistrée à la
Sous-Préfecture de Grasse (06) N° 7803/88

Important notice

Individual copies of the present document can be downloaded from:

<http://www.etsi.org>

The present document may be made available in more than one electronic version or in print. In any case of existing or perceived difference in contents between such versions, the reference version is the Portable Document Format (PDF). In case of dispute, the reference shall be the printing on ETSI printers of the PDF version kept on a specific network drive within ETSI Secretariat.

Users of the present document should be aware that the document may be subject to revision or change of status. Information on the current status of this and other ETSI documents is available at

<http://portal.etsi.org/tb/status/status.asp>

If you find errors in the present document, please send your comment to one of the following services:

http://portal.etsi.org/chaicor/ETSI_support.asp

Copyright Notification

No part may be reproduced except as authorized by written permission.
The copyright and the foregoing restriction extend to reproduction in all media.

© European Telecommunications Standards Institute 2010.
All rights reserved.

DECT™, **PLUGTESTS™**, **UMTS™**, **TIPHON™**, the TIPHON logo and the ETSI logo are Trade Marks of ETSI registered for the benefit of its Members.

3GPP™ is a Trade Mark of ETSI registered for the benefit of its Members and of the 3GPP Organizational Partners.

LTE™ is a Trade Mark of ETSI currently being registered

for the benefit of its Members and of the 3GPP Organizational Partners.

GSM® and the GSM logo are Trade Marks registered and owned by the GSM Association.

Contents

Intellectual Property Rights	5
Foreword.....	5
Abstract.....	5
1 Scope	6
2 References	6
2.1 Normative references	6
2.2 Informative references.....	6
3 Definitions and abbreviations.....	7
3.1 Definitions.....	7
3.2 Abbreviations	7
4 ARCM integration overview	8
5 Subrack integration in the same ARCM.....	8
5.1 Configuring equipment in an ARCM	8
5.1.1 Subrack location	8
5.1.2 Cabling.....	9
5.2 Mechanical structure of ARCM	9
5.2.1 Opening geometry for the airflow.....	9
5.2.2 Equipment fastening in the ARCM.....	10
5.2.3 Doors	10
5.3 ARCM cooling issues.....	10
5.3.1 Cooling equipment including fans	10
5.3.2 Air Cooling techniques	10
5.3.3 Air filtering	11
5.4 Impact of the implementation of subracks in an ARCM.....	11
5.5 Impact of the temperature on equipment reliability	12
6 ARCM integration in the same telecommunications equipment room	12
6.1 Positioning the ARCM in a room.....	12
6.1.1 Room layout.....	12
6.1.2 Cabling.....	13
6.1.3 Cooling systems	14
6.2 Mechanical structure of ARCMs in the rows	14
6.2.1 Opening geometry for the airflow.....	14
6.3 Cooling systems for a room.....	14
6.3.1 General design considerations	14
6.3.2 Cooling techniques	15
6.3.2.1 Passive cooling.....	15
6.3.2.2 Warm air extraction (without cool air).....	16
6.3.2.3 Fresh air supply with natural release via pressure relief ventilators.....	17
6.3.2.4 Cool air blowing (with or without relative humidity control).....	17
6.3.3 Room air paths	19
6.3.3.1 Room air supply	19
6.3.3.1.1 Free blow.....	20
6.3.3.1.2 Overhead distribution	20
6.3.3.1.3 Raised floor distribution	20
6.3.3.2 Return air path.....	21
6.3.3.2.1 Direct return to side walls at side/end of room.....	21
6.3.3.2.2 Overhead return	21
7 Thermal evaluation of the equipment/room architecture	21
Annex A: Examples of cooling systems in an ARCM in use prior to EN 300 119-5	23
A.1 Single subrack cooling	23

A.1.1	Air outlet located at the top of the ARCM	23
A.1.2	Air outlet located at the front of the ARCM.....	24
A.2	Multiple subrack cooling.....	25
A.2.1	Serial cooling.....	25
A.2.2	Parallel airflow with air inlet located at the front or the bottom of the ARCM.....	26
A.2.3	Parallel airflow with air inlet located at the sides of the rack.....	28
A.3	300 mm ARCM thermal solution.....	29
A.3.1	Current 300 ARCM thermal solutions.....	29
A.3.2	Alternative 300 cabinet solution.....	30
A.3.3	Simulation test result about proposed thermal solution.....	31
A.3.3.1	Mockup configuration.....	31
A.3.3.2	Component test result	32
A.3.4	Air deflector design	32
A.3.4.1	Key factors in air deflector design.....	32
A.3.4.2	Different air deflector mockup test	32
Annex B:	Example of ARCM cooling systems in a room.....	35
B.1	Room - serial cooling	35
B.2	Room - parallel cooling.....	35
B.3	ETSI 300 ARCM in Central Office.....	36
B.3.1	ETSI 300 mm ARCM solution.....	36
B.3.2	ETSI 300 ARCM in CO	37
B.3.3	Alternative ETSI 300 ARCM instalment in CO.....	38
B.3.3.1	Simulation equipment configuration.....	38
B.3.3.2	Simulation results	39
B.3.3.3	Proposed CO arrangement	40
B.3.3.4	300 mm ARCM in CO simulation	41
Annex C:	Bibliography	43
History	44

Intellectual Property Rights

IPRs essential or potentially essential to the present document may have been declared to ETSI. The information pertaining to these essential IPRs, if any, is publicly available for **ETSI members and non-members**, and can be found in ETSI SR 000 314: "*Intellectual Property Rights (IPRs); Essential, or potentially Essential, IPRs notified to ETSI in respect of ETSI standards*", which is available from the ETSI Secretariat. Latest updates are available on the ETSI Web server (<http://webapp.etsi.org/IPR/home.asp>).

Pursuant to the ETSI IPR Policy, no investigation, including IPR searches, has been carried out by ETSI. No guarantee can be given as to the existence of other IPRs not referenced in ETSI SR 000 314 (or the updates on the ETSI Web server) which are, or may be, or may become, essential to the present document.

Foreword

This Technical Report (TR) has been produced by ETSI Technical Committee Environmental Engineering (EE).

The present document applies to all telecommunications racks/cabinets, miscellaneous racks/cabinets and subracks forming part of the public telecommunications network and defined in EN 300 119 series [i.1].

Abstract

It is often necessary to integrate different subracks into the same rack/cabinet and different racks/cabinets into a common equipment room sharing the common room environment. The integration between equipment and the room is increasingly more important. The present document is intended to provide assistance in integration of equipment and room environment to ensure that the equipment has the required environment and that each equipment rack/cabinet is not detrimental to the other equipment in the locality.

It should be an aid for all integrators and designers with their different elementary knowledge to integrate.

1 Scope

The present document is an aid for all integrators of telecommunication and IT equipment to minimize thermal problems. It establishes recommendations for the thermal management of racks/cabinets, miscellaneous racks/cabinets and locations.

The present document considers only the thermal factors. The integrator should consider the thermal factors in conjunction with the EN 300 119 series [i.1] and other non-thermal factors.

2 References

References are either specific (identified by date of publication and/or edition number or version number) or non-specific.

- For a specific reference, subsequent revisions do not apply.
- Non-specific reference may be made only to a complete document or a part thereof and only in the following cases:
 - if it is accepted that it will be possible to use all future changes of the referenced document for the purposes of the referring document;
 - for informative references.

Referenced documents which are not found to be publicly available in the expected location might be found at <http://docbox.etsi.org/Reference>.

NOTE: While any hyperlinks included in this clause were valid at the time of publication ETSI cannot guarantee their long term validity.

2.1 Normative references

The following referenced documents are indispensable for the application of the present document. For dated references, only the edition cited applies. For non-specific references, the latest edition of the referenced document (including any amendments) applies.

Not applicable.

2.2 Informative references

The following referenced documents are not essential to the use of the present document but they assist the user with regard to a particular subject area. For non-specific references, the latest version of the referenced document (including any amendments) applies.

- [i.1] ETSI EN 300 019 (all parts): "Environmental Engineering (EE); Environmental conditions and environmental test for telecommunications equipment".
- [i.2] CENELEC EN 60950-1 (2006): "Information technology equipment - Safety - Part 1: General requirements".
- [i.3] ETSI EN 300 119-1: "Environmental Engineering (EE); European telecommunication standard for equipment practice; Part 1: Introduction and terminology".
- [i.4] ETSI EN 300 119-2: "Environmental Engineering (EE); European telecommunication standard for equipment practice; Part 2: Engineering requirements for racks and cabinets".
- [i.5] ETSI EN 300 119-3: "Environmental Engineering (EE); European telecommunication standard for equipment practice; Part 3: Engineering requirements for miscellaneous racks and cabinets".

- [i.6] ETSI EN 300 119-4: "Environmental Engineering (EE); European telecommunication standard for equipment practice; Part 4: Engineering requirements for subracks in miscellaneous racks and cabinets".
- [i.7] ETSI EN 300 119-5: "Environmental Engineering (EE); European telecommunication standard for equipment practice; Part 5: Thermal management".
- [i.8] Void.
- [i.9] Void.
- [i.10] Void.
- [i.11] ETSI EN 300 386: "Electromagnetic compatibility and Radio spectrum Matters (ERM); Telecommunication network equipment; ElectroMagnetic Compatibility (EMC) requirements".
- [i.12] ETSI EN 300 019-1-3: "Environmental Engineering (EE); Environmental conditions and environmental tests for telecommunications equipment; Part 1-3: Classification of environmental conditions; Stationary use at weatherprotected locations".
- [i.13] IEC TR 62380: "Reliability data handbook - Universal model for reliability prediction of electronics components, PCBs and equipment".

3 Definitions and abbreviations

3.1 Definitions

For the purposes of the present document, the following terms and definitions apply:

ambient: spatial maximal

NOTE: As defined in EN 300 019 [i.1]) temperature of the air entering the rack/cabinet.

cabinet: free-standing and self-supporting enclosure for housing electrical and/or electronic equipment

NOTE: It is usually fitted with doors and/or panels which may or may not be removable.

equipment: equipped subracks, racks/cabinets and miscellaneous racks/cabinets

integrator: end user/operator of telecommunication or IT equipment or their agent

NOTE: For example, an equipment manufacturer could be an operator's agent.

micro-climate: conditions found within the rack/cabinet/miscellaneous rack/cabinet creating a local ambient for the subrack

NOTE: In practice this will typically result in elevated temperatures and reduced relative humidities to those quoted in EN 300 019 [i.1].

Miscellaneous Rack/Cabinet (MRC): accommodates subracks of several different types of equipment and suppliers

NOTE: It is freely configurable by the Integrator.

Rack: free-standing or fixed structure for housing electrical and/or electronic equipment

3.2 Abbreviations

For the purposes of the present document, the following abbreviations apply:

AHU	Air Handling Unit
ARCM	Any Rack, Cabinet and Miscellaneous rack/cabinet
CO	Central office

DC	Data Centre
EMC	Electro Magnetic Compatibility
IT	Information Technology
MRC	Miscellaneous Rack/Cabinet

4 ARCM integration overview

The integration can be broken down into:

- Positioning equipment in ARCMs including routing the cables.
- Analysing the possible impact of thermal issues on the configuration of racks/cabinets (e.g. location of racks/cabinets) and MRCs (e.g. location, openings, placement of baffles).
- Providing the cooling solutions.

During the integration the following parameters have to be taken into account:

- The available volume.
- The maximum ambient temperature/micro-climate.
- The provision of coherent air flow to avoid hot spots.
- The functional thermal limits of equipment.
- The cabling space

The overall cooling effectiveness needed depends in principle on the type of equipment to be cooled and thermal requirements to be complied with.

Special attention should be taken to check the impact of the installation of different equipment in the same ARCM on their functional thermal limits.

It is often very helpful to check, by suitable hand calculation, thermal simulation and measurement, whether the integration is applicable for the purpose.

5 Subrack integration in the same ARCM

5.1 Configuring equipment in an ARCM

This activity consists of choosing how to combine the different subracks and the cabling in the ARCM.

5.1.1 Subrack location

This phase consists of positioning the different subracks in the ARCM.

The distribution of subracks should take into account the following parameters:

- Maximum power dissipated by the equipment for the maximum traffic load or its intended operational state. For instance, knowledge of the maximum power dissipated will allow the integrator to locate the highest dissipating subracks at the top of the ARCM in order to minimize the increase of temperature experienced by the other subracks.
- Subracks working maximum temperature: For example, subracks, which withstand high temperature can be installed at upper part of the ARCM (where generally the temperature is the highest).

- Thermal restrictions of each subrack. If possible, place the most restrictive subrack in an area not heated by other subracks, for example, at the bottom in an ARCM with natural convection cooling system, or in an area receiving fresh air with as high an air velocity as necessary.
- The position and area of air inlet and air outlet for the different subracks. The porosity of the surface and the obstacles to the airflow in front of the ventilation surface should also be taken into account.
- Air inlet velocity, air outlet velocity of different subracks and estimated air outlet velocity of the ARCM.
- Air velocity inside the ARCM: This should be enhanced as much as possible, by means of subrack distribution or additional subracks, e.g. fans, baffles, etc.
- Environmental class according to EN 300 019 [i.1] (for instance maximum air ambient temperature).
- Estimated direction of the airflow inside the ARCM. It is not recommended to have in the same ARCM two subrack types which blow the air in the opposite direction.
- Recirculation of the air. Where possible, the recirculation of air between subracks should be avoided, unless the design is specifically for serial cooling of the subrack. The risk of recirculation is higher when subracks with different airflow paths are installed together in the ARCM. For instance, where the increase of temperature is significant, the hot air exhausted by a subrack should be prevented from being reused to "cool" another one. Check also the possibility of introducing additional elements to enhance the airflow, such as baffles (to guide the air flows), vertical covers (to improve the performance of the convection, natural or forced), plates (to separate flows and minimize re-circulation).

It is sometimes necessary to assign some space between two adjacent subracks to accommodate the location of the air inlets or the air outlets. This information is generally provided by the manufacturers and detailed in the user's guides.

5.1.2 Cabling

It is recommended that cables within the ARCM are routed in order to minimize the impact on the airflow, without restricting access to other subracks and making best use of the side cable access channels.

Cables and cable bundles can represent a significant obstruction to airflow. When undertaking an analysis of thermal performance accounting for airflow in an ARCM it is important that the analysis takes into account the location of significant amounts of cabling (or wave guides) along with the significance of their obstruction.

5.2 Mechanical structure of ARCM

The thermal issues may have an impact on the mechanical structure of the ARCM, i.e.:

- Opening geometry definition.
- Equipment fastening in the rack.
- Definition of the doors and side panels.

This may lead to the choice of a new kind of ARCM (well adapted to the specific application) or to reuse an existing product (generally, in this case, a compromise has to be found between requirements and performance of the ARCM).

5.2.1 Opening geometry for the airflow

To dissipate the power from the equipment the following parameters have to be considered:

- Position of openings.
- Shape of openings.
- Area and porosity of openings.
- Airflow direction due to the shape of the grid (with or without deflector of air inlet or outlet).

- Air inlet and air outlet temperature.

NOTE: In case of shielded racks, the openings may be well adapted to equipment frequencies.

5.2.2 Equipment fastening in the ARCM

The fastening elements should not obstruct the air circulation. For instance, in the case of transversal cooling, the mounting brackets should be well designed to allow the subrack to be cooled. For ETSI compliant equipment this should already be the case.

5.2.3 Doors

When it is necessary to cool the subracks, cabinet doors, when present, can be punched with a lot of small holes or a grid may be placed at lower part of the door, allowing air access to a front ventilation channel. The degree of perforation may be determined using any of the assessment techniques identified in clause 4.

5.3 ARCM cooling issues

It is a primary requirement for all equipment to be cooled by natural convection. The mechanical architecture of the ARCM should be designed to promote natural convection. Assisted cooling methods should be employed only when natural convection methods are unable to deal with the relevant heat dissipation.

While defining the cooling issues of ARCM the integrator may check the different cooling possibilities:

- What types of cooling techniques have to be used?
- Is natural convection sufficient to provide enough cooling for the equipment and to ensure that the temperature of the issuing air does not exceed 75 °C (in accordance with EN 60950-1 [i.2]) in worst-case conditions (specified in the EN 300 019 series [i.1])?
- Are additional fan trays necessary to supply/extract the air to/from the ARCM?
- Is air filtration necessary?

5.3.1 Cooling equipment including fans

During the configuration of the cooling equipment, the following issues have to be taken into account:

- Power supply interface requirements.
- EMC performance (e.g. voltage dips and spikes generated into the power network).
- Acoustic noise.
- Safety requirements (including fire protection).

5.3.2 Air Cooling techniques

Many cooling solutions already exist but they fall into two main categories:

- Serial cooling.
- Parallel cooling.

Annex A presents cooling system examples. Other approaches are possible. The present document helps the integrator to mix different equipment in an ARCM.

5.3.3 Air filtering

In some instances (see EN 300 019 series [i.1]) air filters (normally provided at the room level) could be required at the equipment inlets. Where air filters are used, precautions should be taken in order to clean or replace them periodically. If the filter is not cleaned or replaced, the micro-climate air inlet temperature for the subracks can increase dramatically, or the air volume through the equipment be reduced and these changes in ventilation performance can lead to equipment malfunction.

5.4 Impact of the implementation of subracks in an ARCM

When integrating a subrack in an ARCM, the integrator should implement subracks that fulfil EN 300 019 series [i.1].

Once implemented in the ARCM these subracks (mainly the ones located at the upper part of the ARCM) are subjected to temperatures which may exceed the maximum temperature specified in the EN 300 019 standards [i.1]. If this subrack does not withstand temperature higher than the maximal temperature specified in the EN 300 019 standards [i.1], then, the ARCM will not be considered to be compliant with the EN 300 019 series [i.1]. In this case the configuration should be modified, for example, a subrack may be moved, removed or the subrack configuration itself be modified.

As an example, in EN 300 019-1-3 [i.12] class 3.1 for a normal controlled environment the ambient temperature will be 40 °C or less for 99 % of the year. Using serial cooling of equipment shown in figure 5.4a is likely to result in the equipment in the MRC not operating in an environment that is in accordance with EN 300 019-1-3 [i.12]. This would be true unless the temperature rise of the subracks is reduced (perhaps by increasing airflows, figure 5.4b) so that the inlet temperatures to all subracks is less than 45 °C. This can be resolved by configuring the MRC with parallel airflow (figure 5.4c) or limiting the number of subracks in the MRC (figure 5.4d).

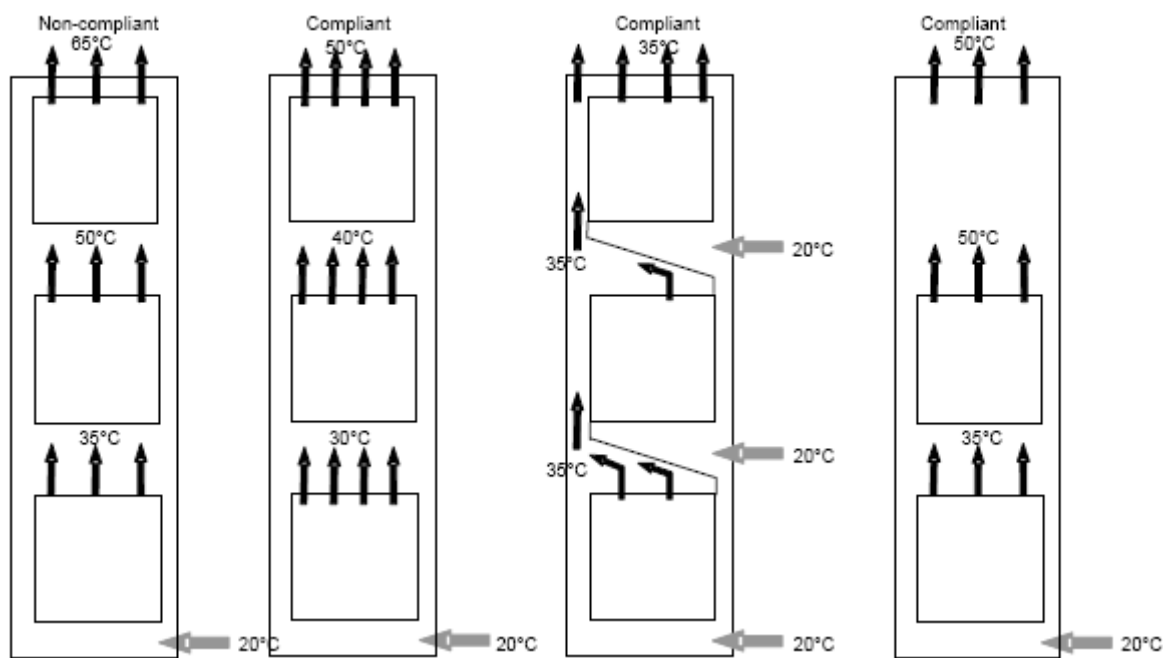

Figure 5.4a

Figure 5.4b

Figure 5.4c

Figure 5.4d

In practice, the room will not deliver the cool air from the fresh air or mechanically cooled supply without some degree of mixing. It is normal practice therefore, to design the cooling system for a normal high air temperature (see EN 300 019-1-3 [i.12] table 1) lower than 40 °C, say 30 °C to 35 °C, so that the temperature of the air entering all ARCMs remains less than 40 °C (see clause 6).

The objective is to configure the MRC through the use of appropriate cooling strategies or careful equipment selection, so that the combination of subracks still satisfy the EN 300 019 series [i.1]. Where more space is required for increased airflow then a larger rack/cabinet could be used by the integrator, for example 900 mm width. In this case the 900 mm width racks offers the possibility of introducing equipment according to the EN 300 119-4 [i.6] leaving an increased space for airflow. In this case it is necessary to verify that this size is acceptable to the operator for their room layout.

5.5 Impact of the temperature on equipment reliability

It should be considered that the failure rate of an electronic circuit depends by the working temperature conditions. The IEC TR 62380 [i.12] provides a model for the reliability prediction of electronic components. The standard assumptions for the reliability prediction are an average room temperature of 20 °C and an average temperature surrounding the components of 40 °C. Then, if the room temperature is higher than 20 °C a higher failure rate can be expected for certain components that have the failure rate with high dependence by the temperature.

In the serial cooling the upper subracks in the ARCM are exposed to highest temperatures and then a higher failure rate may occur.

In order to get the reliability prediction in line with the ARCM configuration, it is recommended to perform the reliability prediction at the temperature condition of each subrack in the ARCM when the serial cooling technique is used (e.g. at or at the expected room temperature when the parallel cooling technique is used). The reliability data at the different room temperatures can be requested to the equipment supplier.

6 ARCM integration in the same telecommunications equipment room

6.1 Positioning the ARCM in a room

This involves positioning the different racks and the cabling in the room.

6.1.1 Room layout

In a room, it is recommended to line up the ARCM in rows, which will be separated by aisles as stated in EN 300 119-2 [i.4]. As an example see the room layout shown below in figure 6.1.1.

Space for cooling equipment is determined by the operator's requirement.

The minimum aisle width is 750 mm as stated in EN 300 119-2 [i.4], but any aisle width can be larger as determined by the operator's requirement or as required to satisfy health and safety requirements.

300 mm deep equipment is normally placed back to back (or to a wall) as stated in EN 300 119-2 [i.4]. In this case all aisles are to the front of the equipment and therefore will require cool air supply so that they are cold aisle.

Where 600 mm equipment is used then a cold aisle is normally created with cool air being supplied in front of the equipment with a hot aisle to the rear of the equipment. For this approach to be effective it is important that alternate rows or equipment face opposite directions so that they are all "front to front" (cold aisle) or "back to back" (hot aisle).

Two types of ARCM installation can be encountered:

- ARCMs installed on a raised floor. In this case the cool air may be introduced from the floor void directly into the room to create a room environment compliant with EN 300 019 [i.1]. Cool air can also be introduced directly into the ARCM. However this can lead to air distribution problems, e.g. some equipment has too much air while others have insufficient air. This is not preferred unless the integrator can guarantee the correct balancing of the cool air distribution at the raised floor outlets whenever new equipment is installed or equipment is removed. External connections are via the bottom or top of the ARCM.
- ARCMs installed directly on the ground (without raised floor), external connections are via the top of the ARCM and cooling is normally provided via the room.

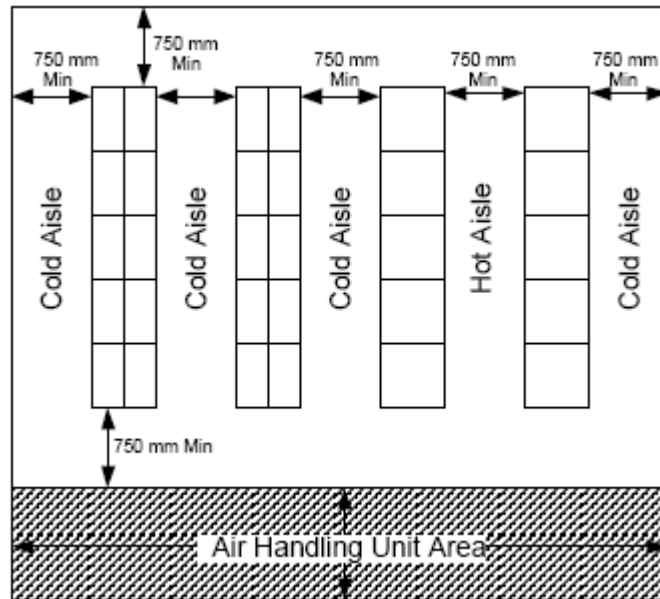

Figure 6.1.1: Room Layout

When determining the layout of ARCMs in a room, the thermal effects of one ARCM on another or of one ARCM row to another need to be considered. ARCMs are positioned in the rows in order to facilitate the inter-rack wiring and to make a complete EMC enclosure for the entire system.

6.1.2 Cabling

The cables are generally routed either over a cable support structure or under a raised floor.

In both cases the cables and the cable support structure should be placed in a way that minimizes the effect on air flow. Placing cables parallel to the ventilation airflow in the main room, or floor void, generally minimizes the effect on airflow. Cables placed perpendicular to the supply airflow into the room (or floor void) are best placed at the opposite end of the room to the ventilation air supply.

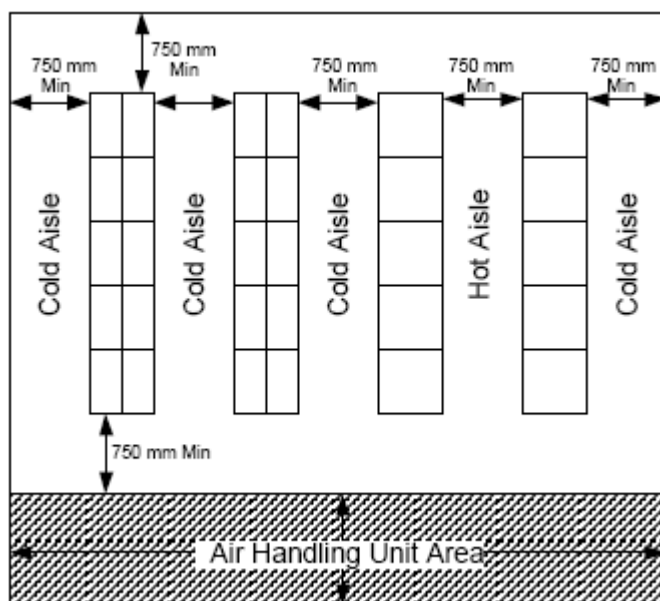

Figure 6.1.2a: Cable position in a floor void

It is important that the cable depth be carefully considered when the cables are in the main air path. Cables in the perimeter zone could be allowed to virtually fill the depth of the air path. However, cables in the air path from the Air Handling Units (AHUs) to the equipment may significantly restrict cooling effectiveness if the proportion of the air path blocked is not controlled. In general cable obstructions can be greater when the cable routes are parallel to the air paths rather than perpendicular.

NOTE: Where possible wave guides should be treated in a similar manner to cables.

The cabling can be arranged over the ceiling or under the floor (as shown in figures 6.1.2b and 6.1.2c), it is important to arrange the cabling to preventing air blockage.



Figure 6.1.2b: Ceiling cabling



Figure 6.1.2c: Underground cabling

6.1.3 Cooling systems

Two cases can be encountered:

- Cooling system exists: in this case, the room layout of the ARCMs has to take into account the existing situation.
- Cooling system does not exist: therefore, the cooling system should be co-ordinated with the room layout. Due to the increase of power dissipated in the equipment, the provision of cooling should be taken into account.
- Consideration should be given in the room cooling design to allow for cooling system component failure. This does not necessarily mean allowing totally redundant systems, e.g. N+1.

6.2 Mechanical structure of ARCMs in the rows

6.2.1 Opening geometry for the airflow

In order to facilitate the cooling of the room, it is recommended that the air outlet of the ARCMs are located in a similar way, in terms of position and direction of airflow.

The recommended configuration is for air to enter the front of the ARCM and leave through the top.

6.3 Cooling systems for a room

6.3.1 General design considerations

The air normally needs to be filtered to remove particles that may be harmful to the equipment. Filtration should achieve contaminant levels (for biological conditions, chemically and mechanically active substances) less than or equal to the limits specified in EN 300 019-1-3 [i.12].

Electrostatic discharge is managed by wearing earthed wristbands. Electrostatic discharges are reduced by wearing earthed wristbands. For information on the electrostatic discharge level withstands by the telecom products refer to EN 300 386 [i.11].

Some cooling systems also offer the potential to control humidity and thus reduce the risk of electrostatic discharge (see clause 6.3.2.3). Where it is considered that corrosion can damage equipment due to high humidity and/or pollution the control of the humidity level should be considered in the design of the cooling system.

Acoustic noise may need to be controlled using acoustic louvers, lined ductwork to meet local environmental regulations.

Where batteries are installed in the facility, then care should be taken to ensure adequate ventilation to adequately dilute and remove any fumes.

In practice, the room will not deliver the cool air from the fresh air or mechanically cooled supply without some degree of mixing. It is good practice therefore, to design the cooling system for a normal high air temperature lower than the highest temperature specified by the reference environmental class (see EN 300 019-1-3 [i.12]) so that the temperature of the air entering all subracks in the ARCMs remains within the maximum temperature defined for the applicable environmental classes of EN 300 019-1-3 [i.12].

6.3.2 Cooling techniques

The following typical cooling techniques can be identified.

6.3.2.1 Passive cooling

For low power applications natural convection can be used where the room airflow is driven by hot air from the equipment rising. An air inlet allowing air into the facility at low level and an air outlet at high level to allow the warm air to leave are required. The inlet and outlet are normally best placed at opposite ends of the facility. Where there is more than one row of equipment then the facility should be configured so that the airflow from the inlet to the outlet is along the aisles. Care should be taken to avoid air filtration overly restricting the airflow.

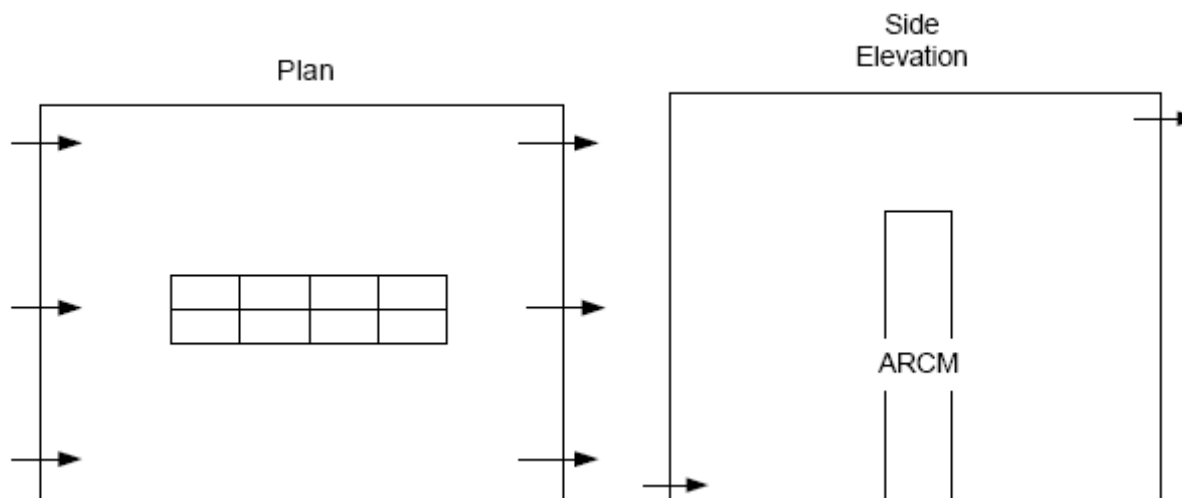

Figure 6.3.2.1a: Option A Passive Cooling

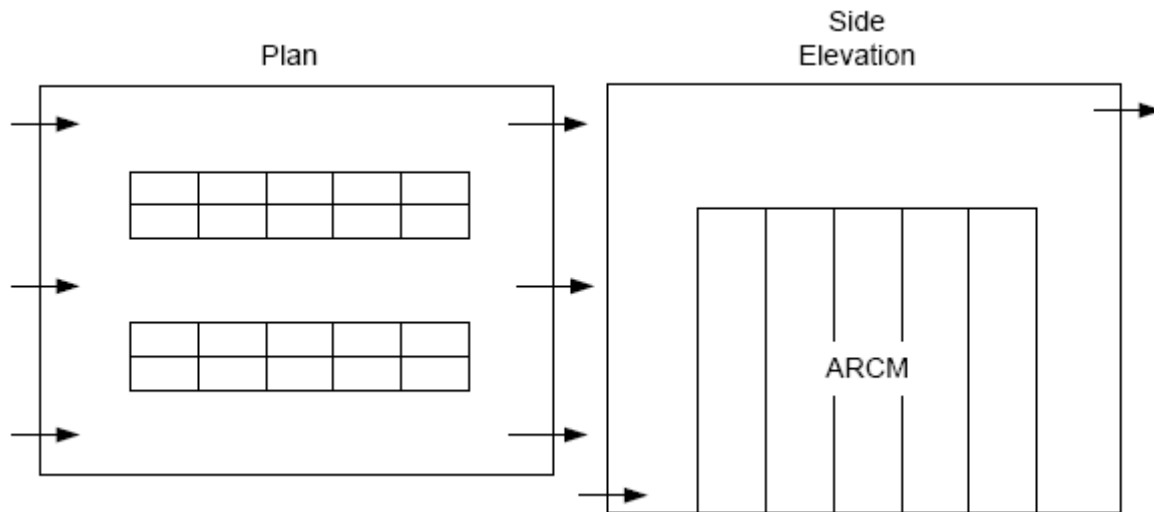

Figure 6.3.2.1b: Option B Passive Cooling

6.3.2.2 Warm air extraction (without cool air)

The room air flow is driven by fans drawing air out of the facility. The fans or ductwork are normally placed at high level in order to remove the warmest air from the facility. Fresh air is drawn in from outside through louvres, normally at low level, to replace the extracted air. The following design issues should be considered.

There is no opportunity for relative humidity control and so the local environmental humidity variations should be considered.

There is no opportunity for control of the incoming air temperature and so the local external ambient temperature variations should be considered.

The ductwork design can be optimized to extract air from local hotspots.

There is no opportunity to distribute the fresh air about the facility.

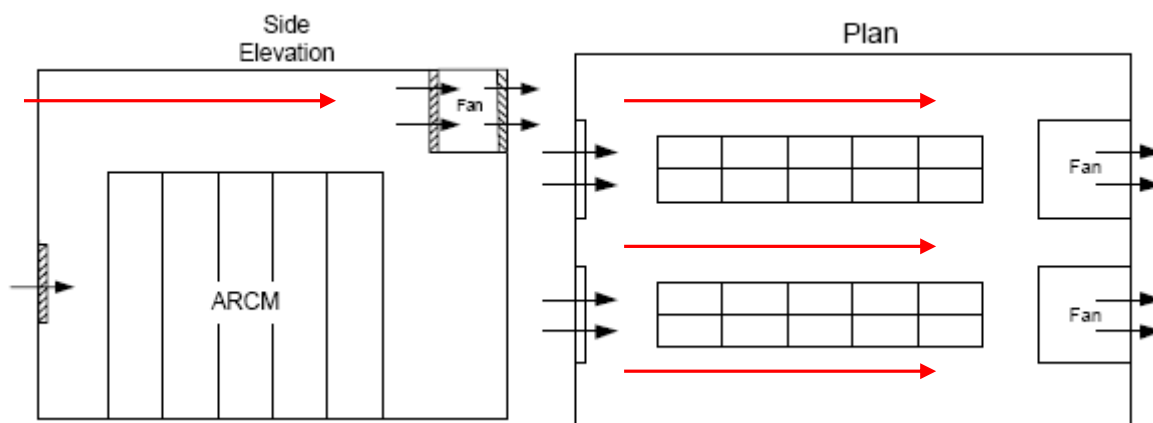

Figure 6.3.2.2a: Option A Warm air extraction (without cool air)

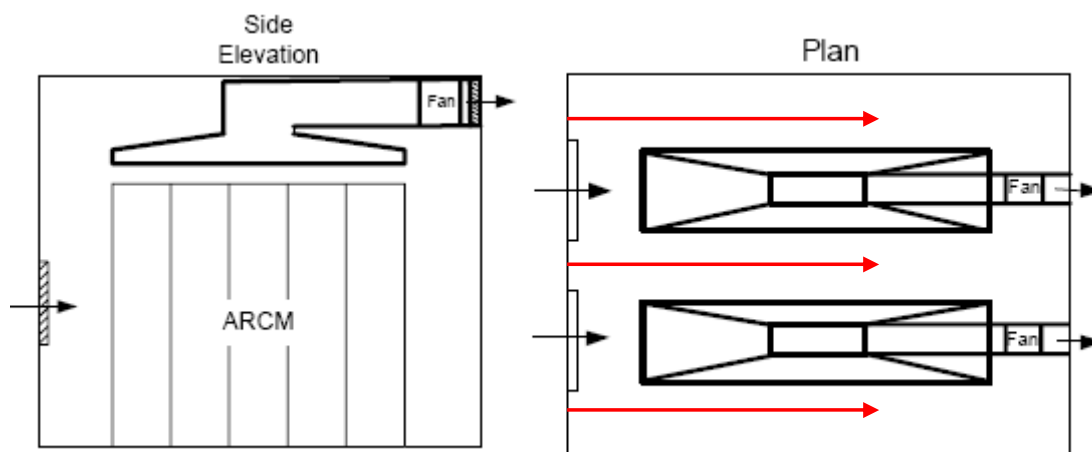

Figure 6.3.2.2b: Option B Warm air extraction (without cool air)

6.3.2.3 Fresh air supply with natural release via pressure relief ventilators

This is the opposite concept to warm air extraction. The airflow in the room is provided by fans blowing fresh air into the facility (note that supply to every aisle as shown in figure 6.3.2.3 may not be required). Air normally leaves through louvers at high level. The following design issues should be considered.

There is no opportunity for relative humidity control and so the local environmental humidity variations should be considered.

There is no opportunity for control of the incoming air temperature and so the local external ambient temperature variations should be considered.

There is no opportunity to collect air directly from hotspots.

Ductwork can be used to deliver the fresh air to locations in the facility where it is most needed.

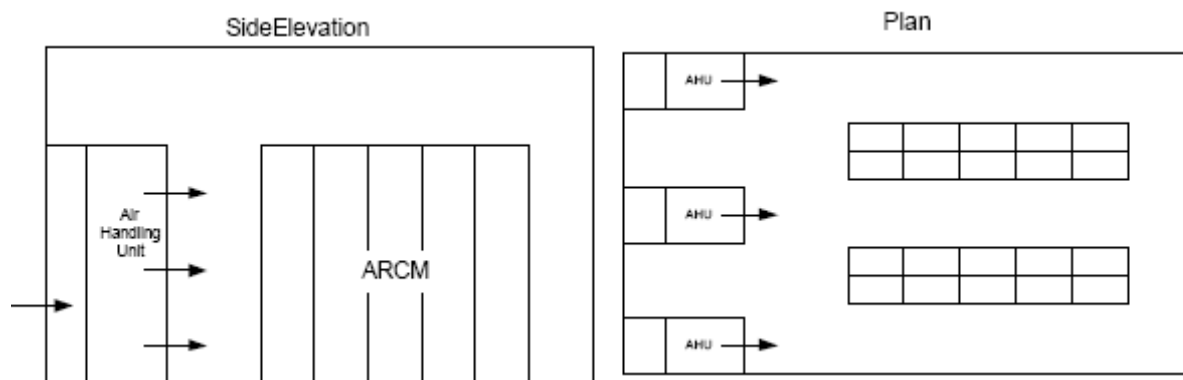

Figure 6.3.2.3: Fresh air supply with natural release via pressure relief ventilators

6.3.2.4 Cool air blowing (with or without relative humidity control)

Cool air blowing is a general term describing a number of implementations where the air supplied to the facility is cooled by a cooling unit before being distributed around the space to cool the equipment. There are a number of different approaches to the cool air distribution as follows:

- Free-blow.
- Overhead distribution.
- Raised floor distribution.

Note that supply to every aisle as shown in figure 6.3.2.4a may not be required.

Warm air can be removed in a number of ways as follows:

- Direct return to side walls at side/end of room.
- Overhead return.

The following design issues should be considered:

- The use of a combination of fresh air and re-circulated air to maximize energy efficiency.
- Humidity control can be incorporated to prevent the risk of static discharge due to the dry atmosphere that can be produced through cooling or where specific equipment requires it. If humidity control is adopted, the design should address whether the volume of fresh air needs to be reduced.
- The choice of air supply and air return system will depend upon the facility construction and the anticipated equipment configuration and heat load.
- When the air is cooled, care should be taken to ensure that it does not fall to near or below the dew point unless humidity control is introduced to eliminate the risk of condensation.

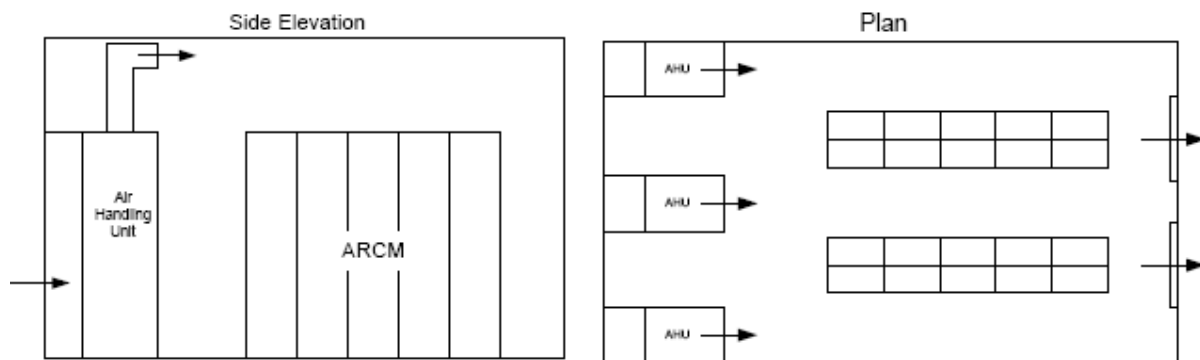

Figure 6.3.2.4a: Option A Free blow at high level

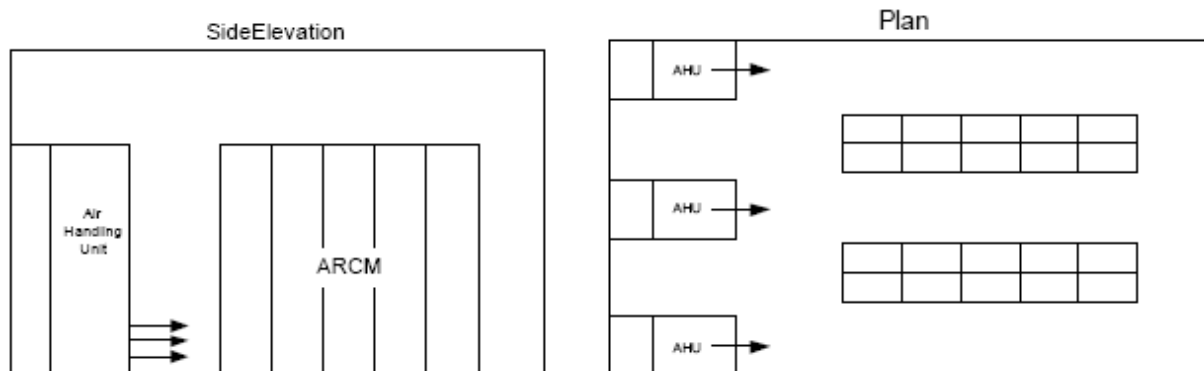

Figure 6.3.2.4b: Option B Free Blow along the aisles

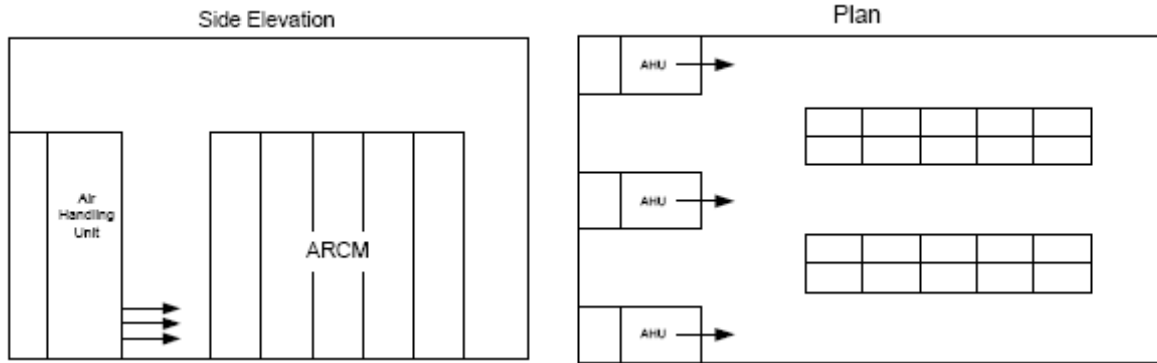

Figure 6.3.2.4c: Option A Overhead Distribution via a ventilated ceiling

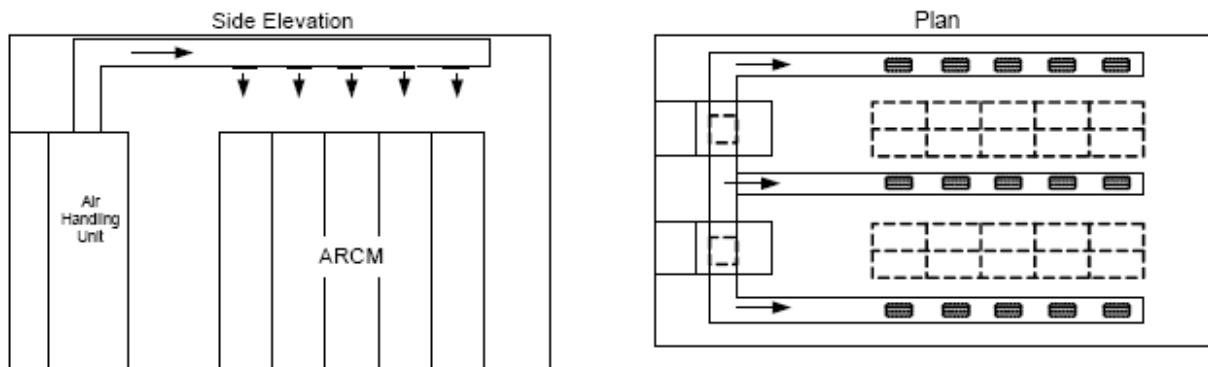

Figure 6.3.2.4d: Option B Overhead Distribution via a network of ducts

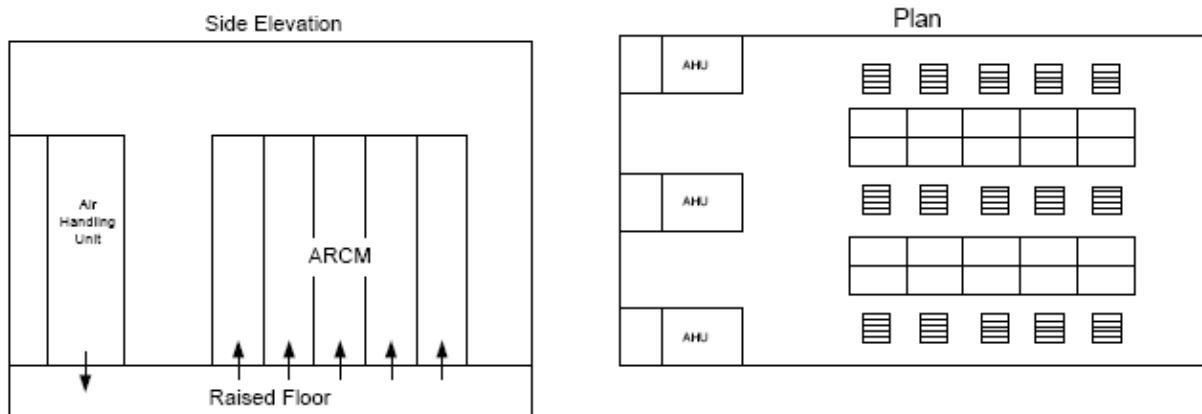

Figure 6.3.2.4e: Floor Distribution

6.3.3 Room air paths

6.3.3.1 Room air supply

One of three different strategies can be adopted to deliver the cooling to the facility.

6.3.3.1.1 Free blow

Free blow is the term used for systems that deliver the cool air to the room through grilles/louvres normally placed at the perimeter of the room. Although the discharge is commonly horizontal and perpendicular to the grille, the grilles may have adjustable blades fitted that can be used to modify the direction of the air and the volume flow rate. Care needs to be taken to ensure that there are no obstructions restricting delivery of the cool air to the equipment. The obstructions can consist of physical obstructions such as equipment, cable trays, etc. or thermal obstructions such as the hot air discharge from the equipment.

There are essentially two configurations:

- Free blow above the equipment (see figure 6.3.2.4a).
- Free blow along the aisles (see figure 6.3.2.4b).

By using large supply air terminals for the cool air entry to the room, the air velocity can be reduced (to less than 1,0 m/s) allowing the cool air to fall and create a "pool" of cool air on the floor of the room. The higher power equipment then draws cool air from the "pool" and carries the heat to high level. This approach is often termed displacement ventilation since the cool air finds and displaces the warm air from the hot equipment. The advantage of this system is that it is less sensitive to changes in equipment configuration. This is because high heat loads naturally attract the cool air and the low velocity means that high vertical temperature stratification is produced with little mixing between the hot air at high level and cool air at low level. The overall result is the potential of higher efficiency for the cooling system.

6.3.3.1.2 Overhead distribution

Overhead distribution is the term used to describe the method where the air is distributed above the equipment in a duct (see figure 6.3.2.4c) or network of ducts (see figure 6.3.2.4d) before being discharged into the facility at strategic locations to cool the equipment. The type of air terminal used to discharge the air into the facility can significantly influence the effectiveness of the air in cooling the equipment and so their type and location should carefully be considered. The design should be such that it is compatible with the other infrastructure to be installed above the equipment.

A ducted installation normally refers to a system using a network of ducts to distribute the air. Commonly there will be a separate duct for each row or pair of rows of equipment. From each duct there will normally be fixed or flexible periodic connections between the ductwork and the grilles or diffusers to deliver cool air to the area in front of the equipment as required.

A plenum refers to a special case of a ducted system where the installation has a single large duct normally covering all of the equipped area. The plenum commonly consists of a ventilated ceiling on the lower face with diffusers discharging air vertically down in front of the equipment or offset from the vertical to avoid discomfort for transitory occupants.

6.3.3.1.3 Raised floor distribution

Raised floor distribution is the term used to describe the method where the equipment is placed on a raised floor. The space created below the floor (the floor void) can then be used for distribution of the cool air to the room or equipment and for the delivery of other services (see figure 6.3.2.4e). The design of the air distribution system should be compatible with any other services installed in the void such as cable trays, pipe-work, etc.

NOTE 1: The design of the air supply into the floor void and the size of the floor void can significantly affect the uniformity of air distribution to the room.

NOTE 2: Care should be taken to ensure that the floor is strong enough to support the weight of the equipment to be installed.

NOTE 3: As the raised floor normally comprises an array of removable tiles, the size of the tiles can be varied to accommodate the needs of different use in the room. For example different size tiles may be installed for the equipment row and the aisle.

NOTE 4: Care should be taken to ensure that there are not unplanned openings in the raised floor that allow the air to pass into the room or equipment in undesirable locations and reduce the cool airflow where it is really required. The same issue exists where cables enter or leave the floor void - care should be taken to limit leakage possibly by using brushes, EMC gaskets or some other method to fill the gap around the cables.

NOTE 5: When using a raised floor ventilation scheme, care should be taken to avoid placing ventilated tiles or direct cooled equipment too close to the cool air entering the void. This is to avoid warm air being drawn back down into the floor void. This happens because close to the air entry the air has high velocity and there is little static pressure.

There are two ways of delivering the cooling to the equipment:

- Via the room where the air passes from the floor void to the room through perforated tiles or floor grilles, the majority of which are normally placed in the aisles in front of the equipment. As the raised floor normally comprises an array of removable tiles this offers the flexibility of adding or removing ventilated tiles as required as and when the equipment configuration changes. These ventilated tiles may also have modulating dampers fitted to allow the operator to balance the airflows and achieve the required cool air distribution.
- Direct cabinet cooling from floor is where the air passes directly from the floor void into the equipment. Although this offers the advantage that the cool air does not have the opportunity to mix with warmer room air before reaching the equipment it should be noted that this can lead to air distribution problems, e.g. some equipment has too much air while others have insufficient air. This is not preferred unless the integrator can guarantee the correct balancing of the cool air distribution at the raised floor outlets whenever new equipment is installed or equipment is removed.

6.3.3.2 Return air path

6.3.3.2.1 Direct return to side walls at side/end of room

This approach represents the simplest way to remove the warm air from the room. It comprises grilles or louvres placed around the perimeter of the room for the exhaust air to be expelled or returned to the air conditioning system. Care should be taken to avoid locations that draw the warmer air past equipment intakes. For example, if the return air is on the top of a down-flow unit, the return air grille should be higher than the top of the equipment nearby. This will avoid the hot stratified layer being drawn down and into the equipment.

6.3.3.2.2 Overhead return

This is a method where a network of ducts or a single duct collect the hot air from above the equipment. There are two alternatives:

- The network of ducts offers the opportunity for the distributed grilles to collect the warm air from every row or pair of rows of equipment separately. In particular it allows the hot air from high heat dissipation equipment to be collected more efficiently and thus it can address hot spots effectively.
- The plenum approach is essentially a large single duct covering the entire equipment area with grilles distributed on the lower face to collect the warmer air.

The disadvantage of these systems is the higher capital cost associated with their supply and installation compared with the direct return approach.

7 Thermal evaluation of the equipment/room architecture

As well as normal hand calculation and other design practices the integrator could also use thermal simulation software to check, before installation, that the chosen architecture of the complete system will meet the thermal requirements.

By using both the thermal information (the equipment suppliers have this information available) and the ARCM and room layout, the ARCM and room thermal parameters could be estimated.

The information used for this thermal evaluation is provided by the equipment manufacturer and a minimum set is identified in annex A of EN 300 119-5 [i.7].

If thermal simulation software is available, the integrator can use this information in the following way:

- Build a simple simulation model of the equipment from the mechanical information provided by the manufacturer (physical geometry from annex A).
- Adjust this simulation model in order to obtain the air temperature increase provided by the manufacturer so that it is consistent with total power dissipation. This adjusted model of the equipment can be used to represent in the simulation either:
 - the subrack in an ARCM housing various subracks; or
 - an ARCM in a room housing various ARCMs;

as appropriate.

NOTE 1: The characterization data will provide velocity and temperature of the air leaving the equipment. This can be provided for the circumstance when an obstruction is placed 20 mm from the equipment outlet(s) as well as when the equipment is placed in open space. When simulating the performance of subracks from characterization data, it is important that the cable blockage in the 20 mm gap is accounted for. Where the equipment is such that the cables significantly affect the free area for the airflow, any model should account for the obstruction in order to achieve a good pressure dependant characteristic.

NOTE 2: In some circumstances significant airflow may enter the ARCM from the room through the bottom of the cabinet via a gap between the floor and the sides/front/back of the ARCM. This can be considered equivalent to ventilation from below, provided that both aisles are cooled, and so this could represent a compliant configuration. This gap should be accurately represented in any simulations undertaken.

The evaluation of results, which can be obtained with sufficient confidence, are as follows:

- Air temperature in different places of the ARCM and the room.
- Air velocity and direction of the airflow in different positions in the ARCM and the room.
- Operating point of the ARCM fan tray (air flow, pressure) for the resistance curve of the equipment, to check it lies within the normal operating range of that fan. If not, the fan tray should be changed.
- For ARCMs cooled by natural convection it allows the integrator to verify that natural convection is sufficient to cool the subracks. If not the integrator should revise the configuration or add fan trays in the ARCM.

These results may help the integrator optimize the ARCM and room layout (modification of equipment location, adding a fan unit or additional fan units, changing the type of fan, adding baffles, etc.).

Annex A: Examples of cooling systems in an ARCM in use prior to EN 300 119-5

The examples given in annex A can be applied to ARCMs installed as specified in EN 300 119-2 [i.4] and EN 300 119-3 [i.5].

For reference, the figures indicate cooler air in light grey and hotter air in dark grey.

Table A.1 presents the status of the configurations shown in this annex with reference to EN 300 119-5 [i.7].

Table A.1: Configuration status with reference to EN 300 119-5

Annex	Figure	Compliance with EN 300 119-5
A.1 Single subrack cooling		
A.1.1 Air outlet located at the top of the ARCM	A.1.1a	Compliant
	A.1.1b	Compliant
	A.1.1c	Not preferred (see clause 6.1.1)
A.1.2 Air outlet located at the front of the ARCM	A.1.2a	Not preferred (air outlet at the front and air flow from top to bottom)
	A.1.2b	Not preferred (air outlet at the front)
A.2 Multiple subrack cooling		
A.2.1 Serial cooling	A.2.1a	Compliant
	A.2.1b	Compliant
	A.2.1c	Compliant
A.2.2 Parallel cooling with air inlet at the front or the bottom	A.2.2a	Compliant
	A.2.2b	Compliant (Option not preferred)
	A.2.2c	Compliant
	A.2.2d	Compliant
A.2.3 Parallel cooling with air inlet at the sides	A.2.3a	Compliant
	A.2.3b	Compliant
	A.2.3c	Not preferred (air outlet at the front)

NOTE: Compliant but impact on equipment reliability.

Configurations with perforated front door(s) can operate with or without the front door(s) present.

A.1 Single subrack cooling

This clause describes the commonly used cooling systems of a subrack or a rack designed by a same supplier. The air outlet is located at the top or at the front.

A.1.1 Air outlet located at the top of the ARCM

Figures A.1.1a to A.1.1c present three configurations of ARCMs designed to have the air outlet located at the top of the ARCM. The air inlet can be located at the bottom or at the front. In some cases, the equipment is installed on a raised floor, so the air inlet can be located under the ARCM (care should be taken - see clause 6.1.1). Hereafter the three configurations are described.

In figure A.1.1a, the room air is taken in at the bottom of the ARCM front, up through the subrack and discharged out of the top of the ARCM.

In figure A.1.1b, the room air is taken in at the front of the ARCM via the door (small holes are punched on the door panels or inlet grilles installed in the doors). The air is discharged out of the top of the ARCM.

In figure A.1.1c, the room air is taken in at the bottom of the ARCM through the raised floor. Passing through the subrack it is discharged out of the top of the ARCM.

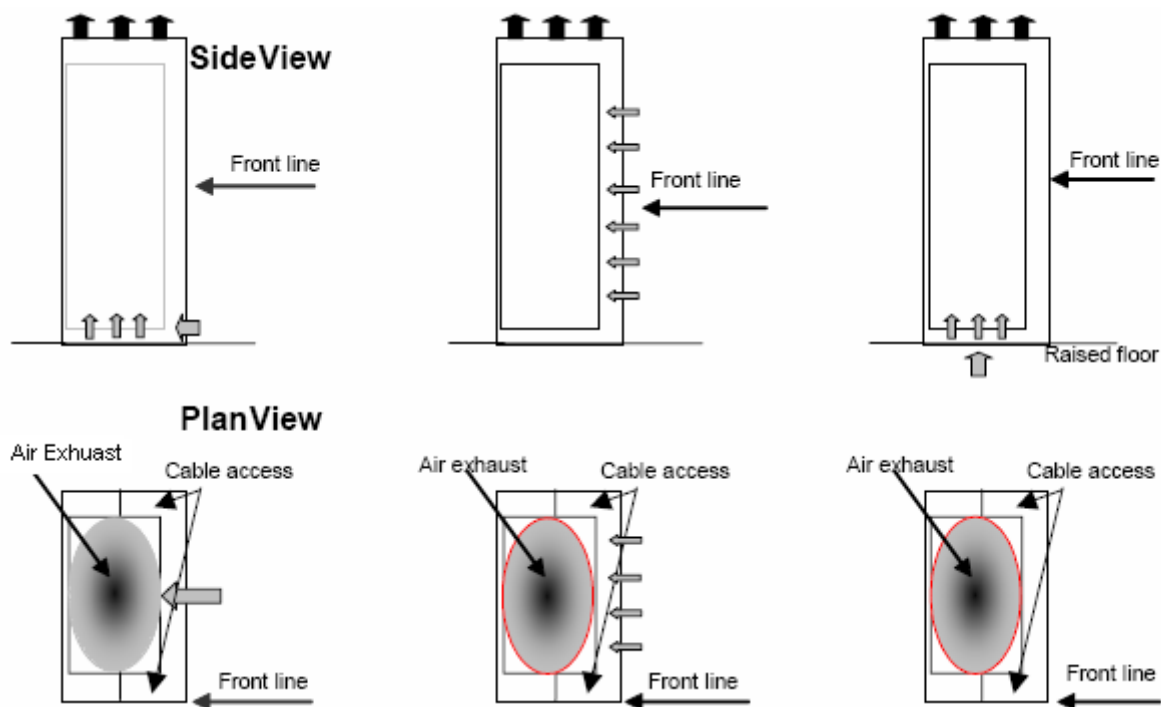

Figure A.1.1a

Figure A.1.1b

Figure A.1.1c

Combinations of the air inlet configurations shown above have also been used. Any of the above configurations could also have an air inlet in the bottom of the ARCM.

A.1.2 Air outlet located at the front of the ARCM

Figures A.1.2a to A.1.2b presents two configurations of ARCMs where air inlet and outlet are located in the front of the rack.

In figure A.1.2a, the room air is taken in at the top of the ARCM front, down through the subrack and discharged out of the bottom of the ARCM front.

In figure A.1.2b, the room air is taken in at the bottom of the ARCM front, up through the subrack and discharged out of the top of the ARCM front.

Side View

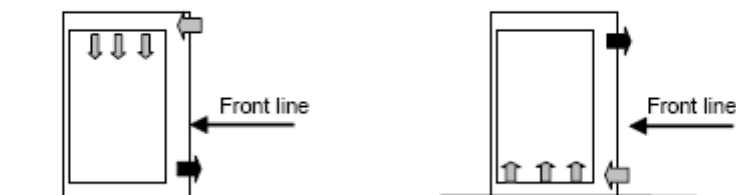

Plan View

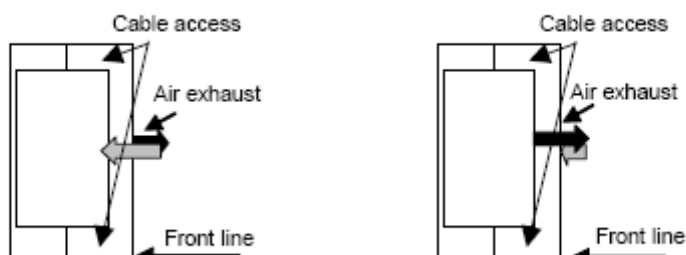

Figure A.1.2a

Figure A.1.2b

Either of the above configurations can be placed on a raised floor. The configuration in figure A.1.2b can also use an air inlet in the bottom of the ARCM.

A.2 Multiple subrack cooling

Clause A.2 describes ventilation schemes used for ARCMs with 2 or more subracks installed. The diagrams are examples only and should not be taken to indicate any preference for a particular number of subracks.

A.2.1 Serial cooling

In figure A.2.1a the room air is taken in at the bottom of the ARCM front, up through each subrack and discharged out of the top of the ARCM.

In figure A.2.1b the room air is taken in at the bottom of the ARCM front, up through each subrack and discharged out of the top of the ARCM. There is additional air intake at the base of each subrack.

In figure A.2.1c the room air is taken in at the front of the ARCM via the doors (small holes are punched on the door panels), up through each subrack and discharged out of the top of the ARCM.

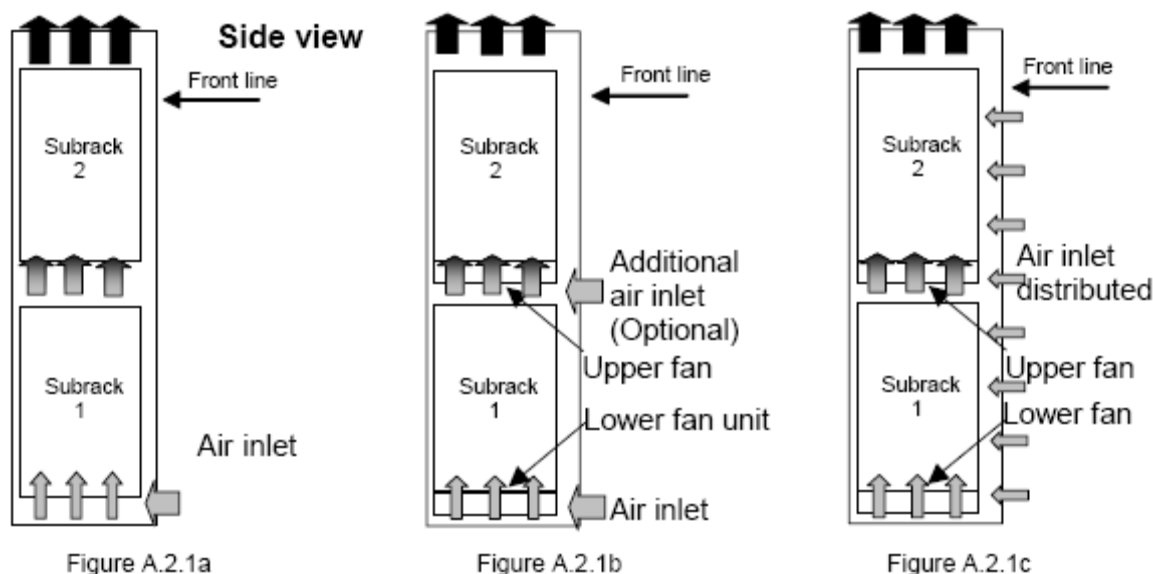

Figure A.2.1a

Figure A.2.1b

Figure A.2.1c

Any of the above configurations could also have an air inlet in the bottom of the ARCM.

A.2.2 Parallel airflow with air inlet located at the front or the bottom of the ARCM

Figures A.2.2a and A.2.2b present two configurations of ARCMs where air inlet are in front or bottom of the ARCM and outlet are located at the top of the ARCM.

In figure A.2.2a the room air is taken in at the front bottom of the ARCM and discharged from the subracks, mainly to the sides of the ARCM, and is discharged out of the top of the ARCM.

In figure A.2.2b the room air is taken in at the front of each subrack and discharged from the subracks, mainly to the rear of the ARCM, and is discharged out of the top of the ARCM.

NOTE 1: Air from lower subracks is prevented from entering the higher subracks by baffles. Air from the top subrack may be discharged out of the top of the ARCM.

NOTE 2: In both figures, the room air could be taken in from the bottom of the front of the ARCM; figure A.2.2b represents the option of air supplied directly from the raised floor.

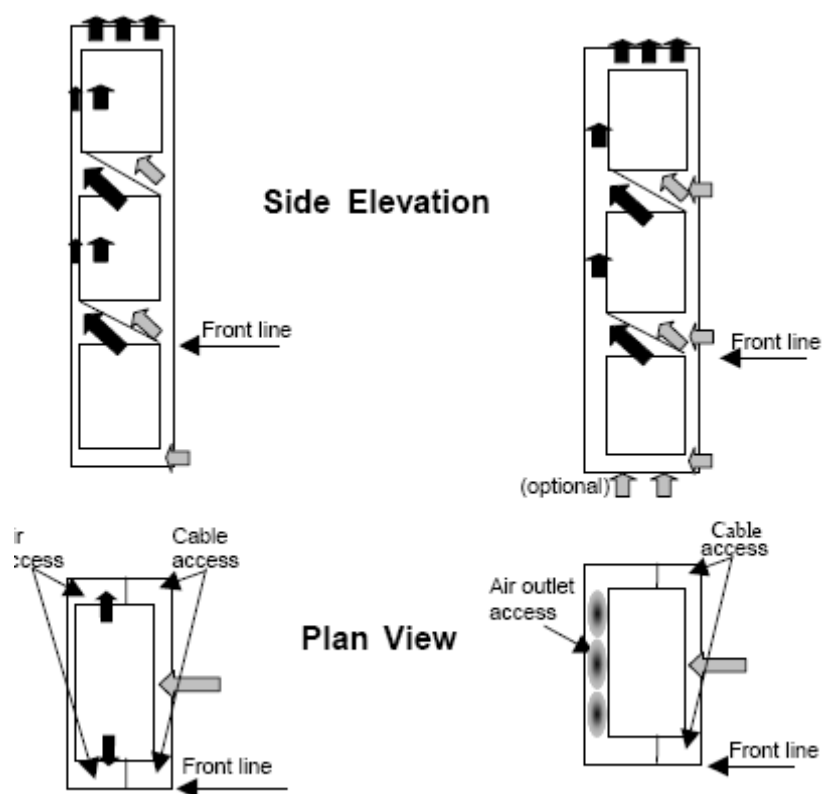

Figure A.2.2a

Figure A.2.2b

Figures A.2.2c and A.2.2d present two configurations of ARCMs where air inlet is in through the front of the ARCM and outlet is located at the top of the ARCM.

In figure A.2.2c the room air is taken in at the front of each subrack and discharged from the subracks, mainly to the sides of the ARCM, and is discharged out of the top of the ARCM.

Figure A.2.2d presents an integration, housing miscellaneous equipment in the same ARCM. The air inlets are located in various places (on the right side, on the front, on the left side, to the bottom). This leads to a complex airflow circulation. For instance, in figure A.2.2d the lower subrack airflow is transversal. For the other subracks the room air is taken in at the front. For the three lower subracks, the air is discharged at the left side, for the others, the air is discharged at the top (with baffles). As a result of this layout the main airflow is discharged at the top of the ARCM between the back of the subracks and the rear of the ARCM. An additional fan unit may be necessary, to enhance the airflow, in this application.

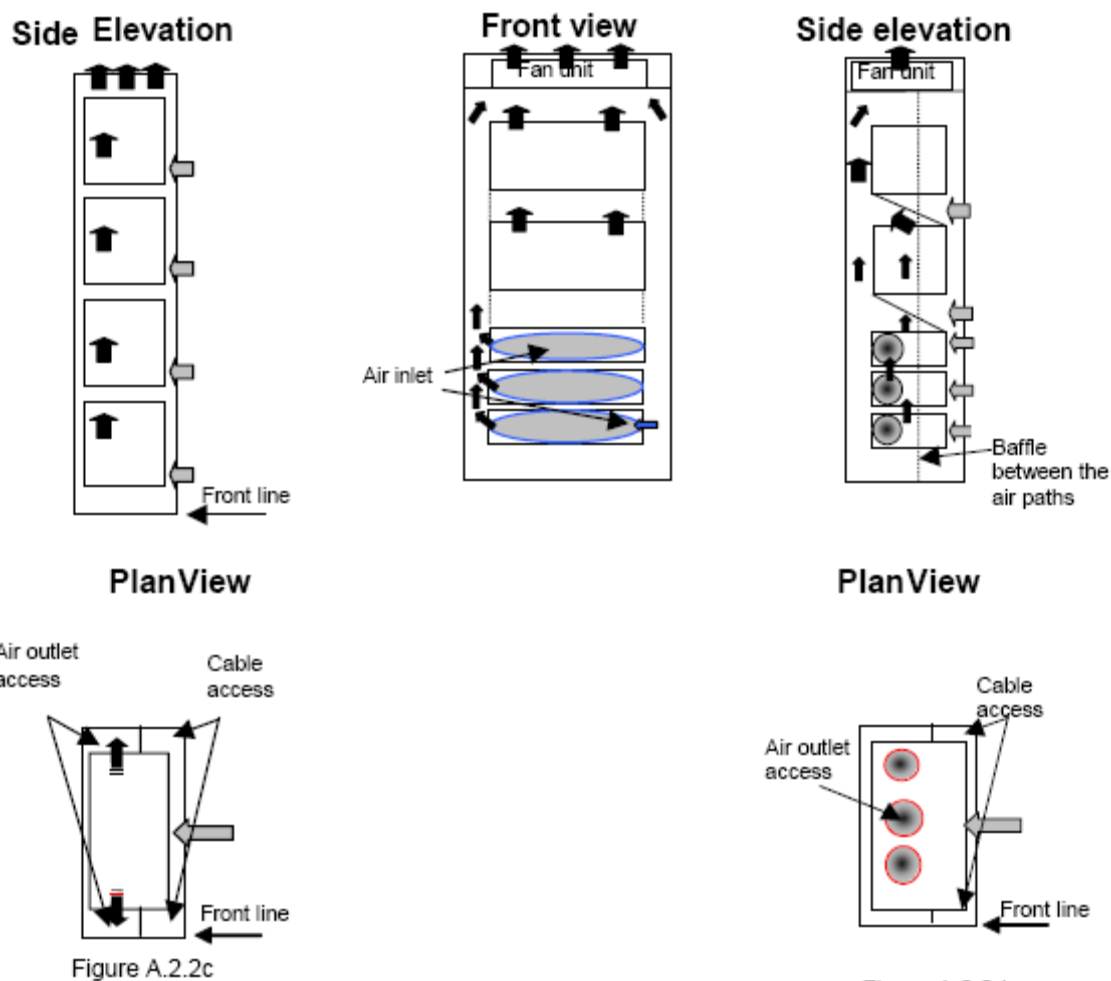

Figure A.2.2c

Figure A.2.2d

A.2.3 Parallel airflow with air inlet located at the sides of the rack

Figures A.2.3a to A.2.3c present three configurations of ARCM where air inlet are located at the sides of the ARCM and outlet are located at the top of the ARCM.

In the configuration A.2.3a the room air is taken in at each subrack from the sides of the ARCM (additional extension panel, the rack width is not changed) and discharged from the subrack to the space between the subrack and the front door of the ARCM (it assumed that doors are fitted) from where it is discharged out of the top of the ARCM.

The configuration A.2.3b is similar to figure A.2.3a without extension panel. The side air inlet surface being smaller the power dissipated in the ARCM could be less.

In the configuration A.2.3c the room air is taken in at each subrack from the sides of the ARCM (additional extension panel) and discharged from the subrack to the front (it assumed that no doors are fitted). This option is not recommended.

NOTE: Air from lower subracks is prevented from entering higher subracks by baffles. Air from the top subrack may be discharged out of the top of the ARCM.

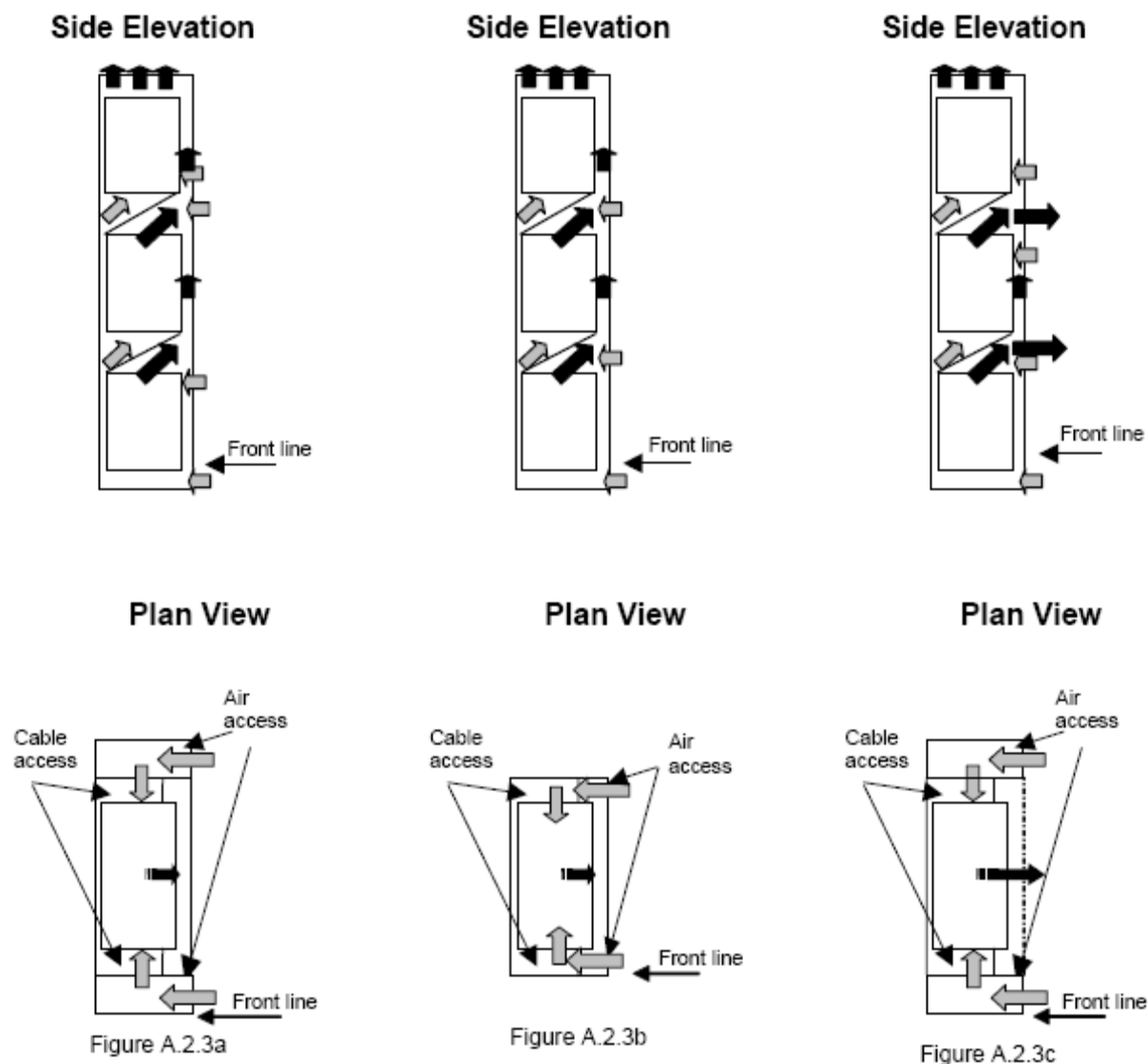

A.3 300 mm ARCM thermal solution

Power consumption of ETSI 300 mm cabinet is historically high, close to 10 kW with 3 kW per rack. It is extremely challenge to solve the thermal problem of the cabinet as well as install such high power equipment inside the central office.

A.3.1 Current 300 ARCM thermal solutions

There are several options of current thermal solutions for 300 mm ARCM. They are classified into three groups, as shown in figure A.3.1.

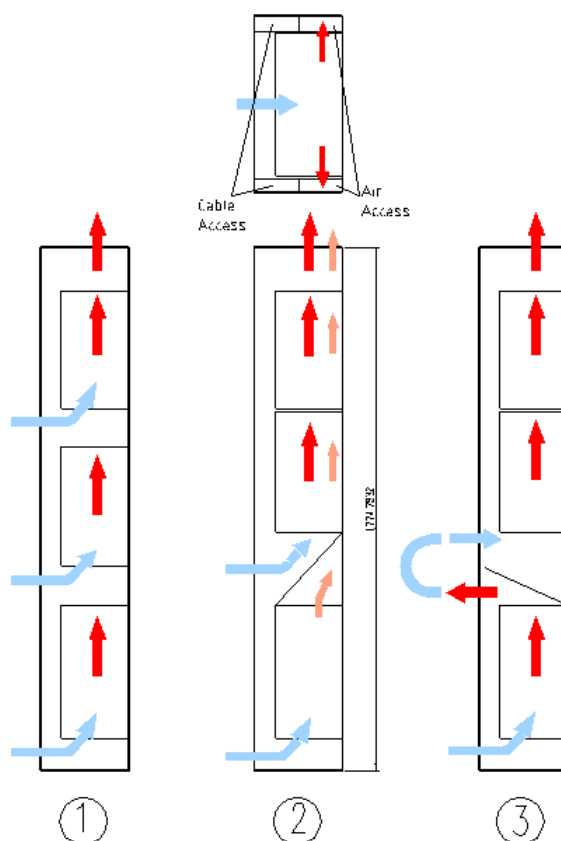

Figure A.3.1: Current thermal solutions for 300 mm ARCM

The first solution is good for low power consumption equipment. With increasing power, it is more and more difficult to arrange the top subrack as mentioned also in clause 5.4, since some portion of the entry air has already been heated by the previous two subracks.

The second solution utilizes the gap in the sides of ARCM. There is little space to discharge air from lower two subracks to the sides of the ARCM, because the width of each side of EN 300 119-3 compliant cabinet is less than 50 mm. It is impractical to discharge the air from the subracks mainly to the rear of the ARCM. Simulation analysis show that when the subracks power reach 2 Kw, the air velocity needs to be higher than 14,8 m/s to maintain an acceptable thermal condition of the subracks and this conditions is not realizable in a EN 300 119-2 compliant cabinet.

The air can directly exit from the bottom subracks, which will reduce the heated air entry to the upper two subracks in the third solution, but, the large part of heat will still be taken by the upper two subracks.

A.3.2 Alternative 300 cabinet solution

In figure A.3.2, the room air is taken in at the front of lower two subracks, discharged from the lower subrack to the sides of the ARCM and from a air deflector to the front of the ARCM, hot air from the upper two subracks is discharged from the top of the ARCM.

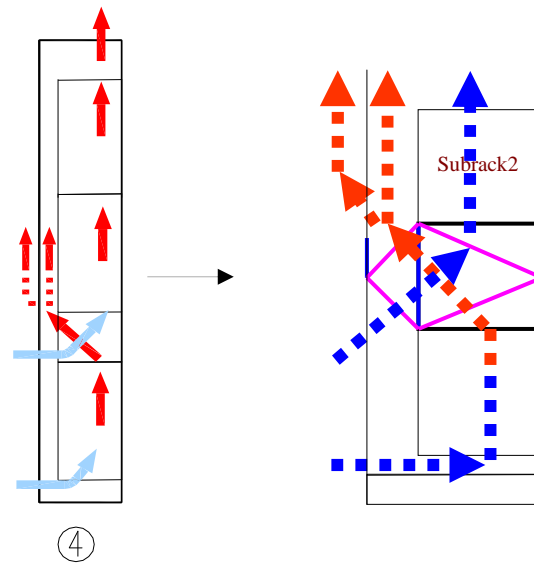

Figure A.3.2: Proposed thermal solutions for 300 mm ARCM

Using air deflector as shown above, the cold room air is taken in at the front of bottom subrack and bottom of mid-subrack through the air deflector, discharged from the lower subracks to the sides of the ARCM and from the middle subrack to the front of the ARCM, the hot air is discharged out of the top of the ARCM. In this case, air channels of the lower subracks and the middle subrack are separated, with careful design, each subrack can gain larger amount of low temperature room air to cool the printed circuit boards, also, the available space for air channel is bigger since the space between the door and the subracks can all be utilized for air discharging, which cause the lower exhausted temperature.

A.3.3 Simulation test result about proposed thermal solution

A.3.3.1 Mockup configuration

The Simulated ARCM consists of three subracks in the 300 mm cabinet. One subrack has 16 boards, 200 W per each. The total power of the cabinet is 7 430 W. There are two fan trays, one is on the top, another is at the bottom. Each fan tray has 3 fans, with maximum 286 CFM and 26,3 mm water pressure.

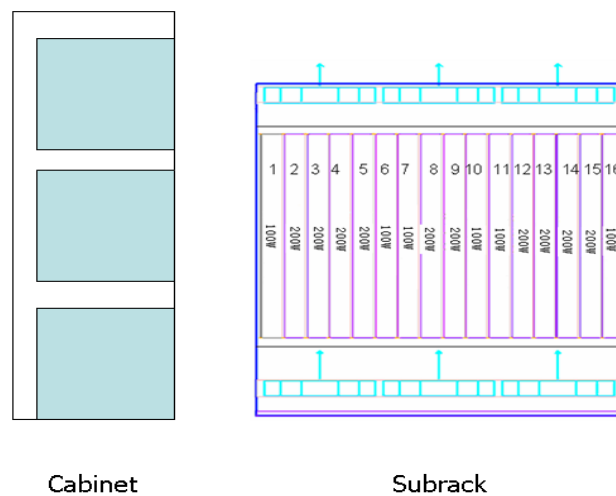

Figure A.3.3.1: Simulated configuration

A.3.3.2 Component test result

The test ambient air temperature is 26 °C and 45 °C, the fan work at half speed and full speed correspondingly.

The components junction temperature of some simulated component is listed in table A.3.3.2.

Table A.3.3.2: Key components junction temperature in different solutions

	Case 1	Case 2		Case 3		Case 4	
	Top subrack	Top subrack	Bottom subrack	Top subrack	Bottom subrack	Top subrack	Bottom subrack
26 °C air (half speed)	118,5	111	117,5	119,3	104,3	110,6	106,4
45 °C air (full speed)	107,5	102,5	107	106	96	103,6	99,2

From table A.3.3.2, we noticed that in both room temperature and 45 °C ambient temperature, the temperature difference between top subrack and bottom subrack in case 4 is smallest among all the four solutions. In this case, air path for cold inlet air and hot outlet air is separated by the air deflector.

The air deflector separates the airflow of the middle subrack and the top subrack. The cold air enters the lower subrack from the cabinet bottom. And after exhausted at the top of the lower subrack, it is directed by the air deflector to the space between the front door and the subracks without mixing with the cold air for the upper subracks. The cold air for the upper two subrack enters from the front of the air deflector which is located at the mid of the cabinet, and then enters the bottom of the upper two subracks. The hot air exhausts from the top of the subrack after heated by the two upper subracks.

A.3.4 Air deflector design

A.3.4.1 Key factors in air deflector design

The cross air path air deflector need to separate the cold air and hot air, it will lead the high pressure loss. Carefully design need to apply to minimum the pressure lost. There are several key factors need to be considered in the design:

- Maximum the air deflector height in the design.
- The inlet and outlet size ration need to be adjusted according to the inlet and outlet air volume.
- Carefully adjust air distributor's number, higher the number, more even the air is distributed, higher the pressure loss.
- The air outlet angle need to designed to reduce the mixture of hot/cold air, and reduce the effect of cabling.
- Thermal insulation material can be considered to reduce the heat exchange between the cold/hot air.

A.3.4.2 Different air deflector mockup test

Two different air deflectors were tested as shown in figure A.3.4.2.a:

- Case I: total height 225 mm, inlet area: 150 mm, outlet area: 75 mm.
- Case II: total height 125 mm, inlet area: 60 mm, outlet area: 60 mm.

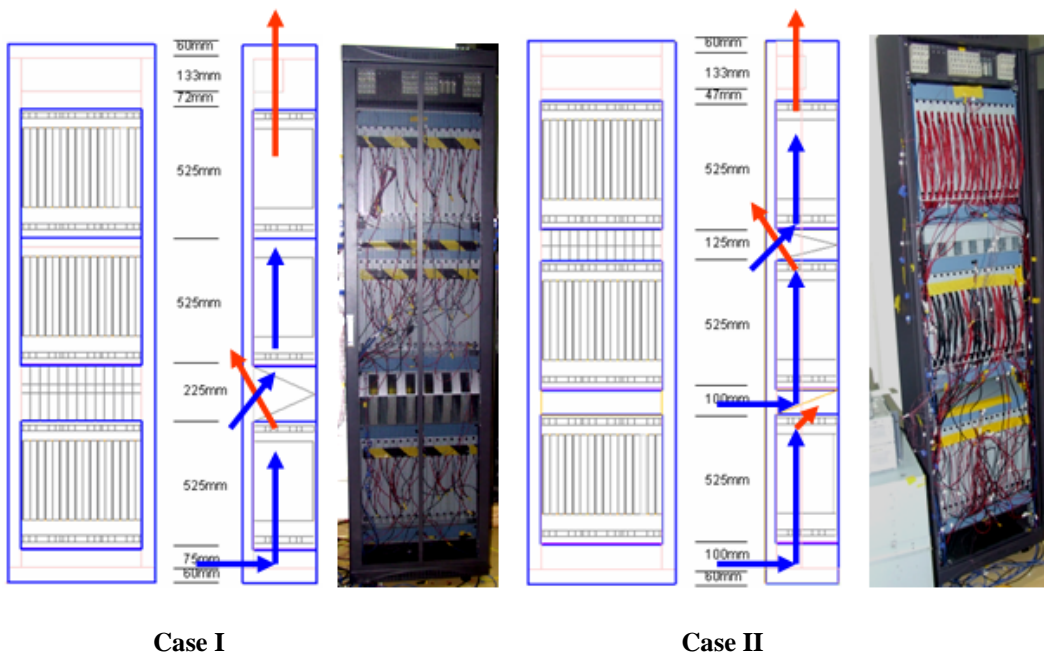

Figure A.3.4.2.a: Test configuration for different size air deflector

In case I, cold air has two entries to the system: from the front of the bottom to the bottom subrack and from the air deflector in the middle to the upper two subracks; hot air from the bottom subracks exit through the air deflector from the front; hot air from the upper two subracks (which is arranged serially) exit from the top of cabinet.

In case II, cold air enter the subracks separately, hot air from each subracks exit from three different paths.

Resistance curves of two different sizes air deflector were obtained from wind tunnel experiments. Figure A.3.4.2.b shows the pull air resistance, figure A.3.4.2.c shows the push air resistance. The resistance curves are highly related with the shapes and size design of deflector.

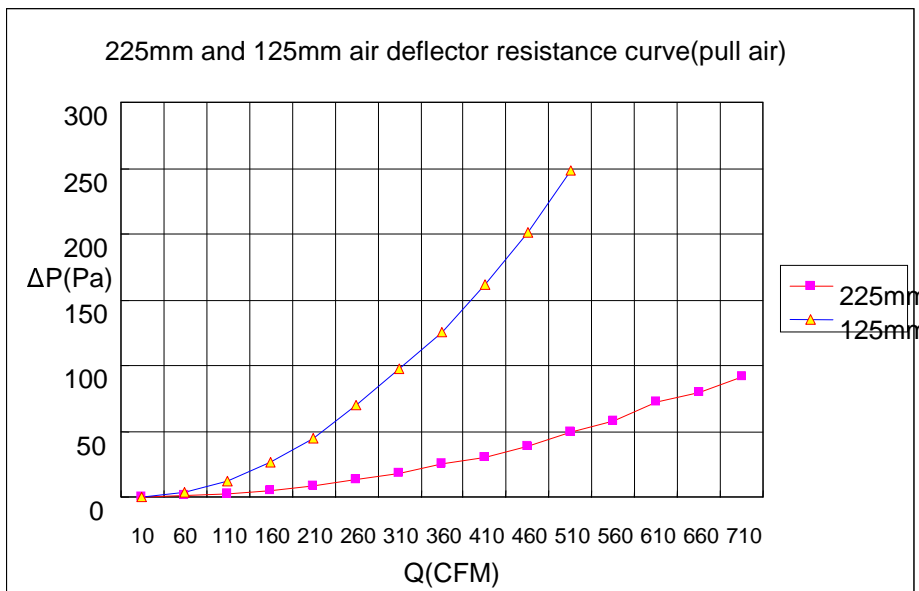

Figure A.3.4.2.b: Test data of pull air pressure loss of deflector

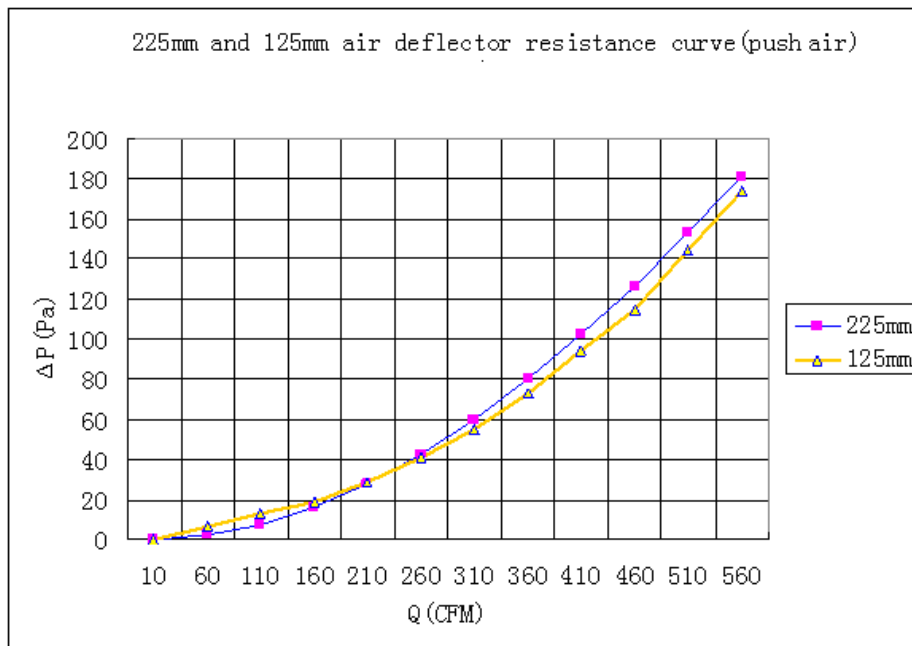

Figure A.3.4.2.c: Test data of push air pressure loss of deflector

For the two cases, we listed the working point at 45, which fan works at full speed in table A.3.4.2.

Table A.3.4.2: Test data from different air deflector

	Case I				Case II			
	Upper two subracks		Bottom subrack		Upper two subracks		Bottom subrack	
	Air (CFM)	P (Pa)	Air (CFM)	P (Pa)	Air (CFM)	P (Pa)	Air (CFM)	P (Pa)
45 °C air (full speed)	700	90	350	70	300	95	350	65

Annex B: Example of ARCM cooling systems in a room

B.1 Room - serial cooling

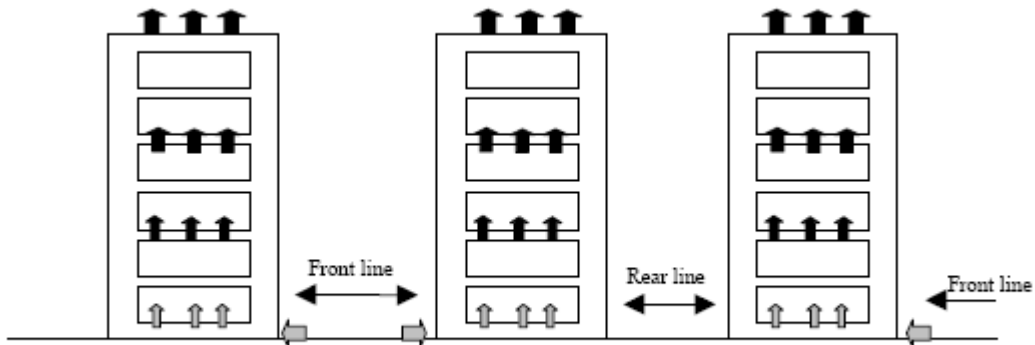

Figure B.1a

In this configuration the room air is taken in at the bottom of the ARCM front, up through each subrack and out of the top of the ARCM.

Air may also be discharged to the top rear of the ARCM.

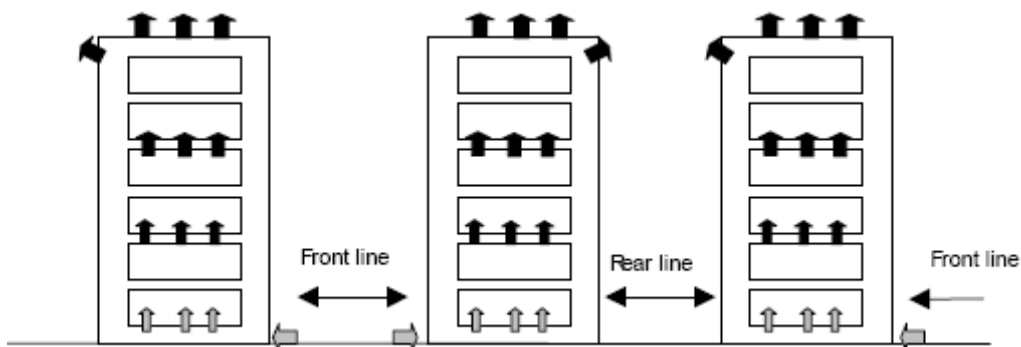

Figure B.1b

B.2 Room - parallel cooling

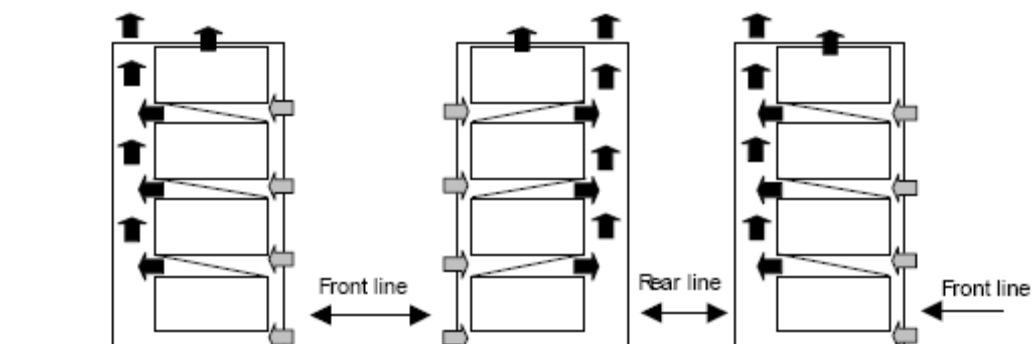

Figure B.2a

In this configuration the room air is taken in at each subrack and discharged out of the top of the subrack to the back of the ARCM and is discharged out of the top of the ARCM. Air from the lower subrack is prevented from entering the higher subrack by baffles. Air from the top subrack may be discharged out of the top of the ARCM.

B.3 ETSI 300 ARCM in Central Office

With the increasing integration density in networking equipment, the power consumption of ETSI 300 mm equipment is close to 10 kW, 3 kW per rack. The cabinet power management as well as the CO power management become a big issue.

In EN 300 119 [i.1], the 300 mm equipment need to be installed back to back as shown in figure B.3.

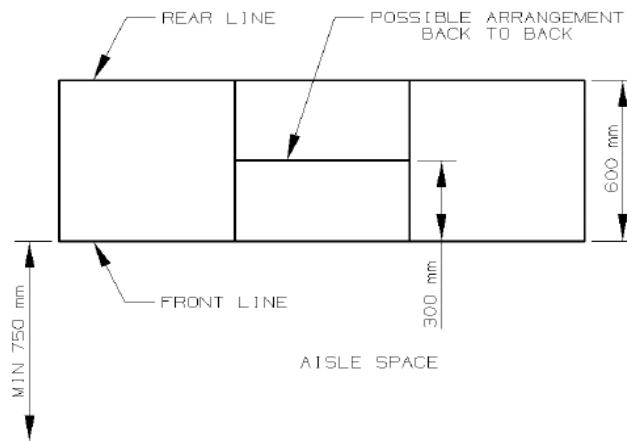

Figure B.3: EN 300 119, 300 mm arrangement

Three different types of 300 mm ARCM thermal solutions are discussed in this clause.

B.3.1 ETSI 300 mm ARCM solution

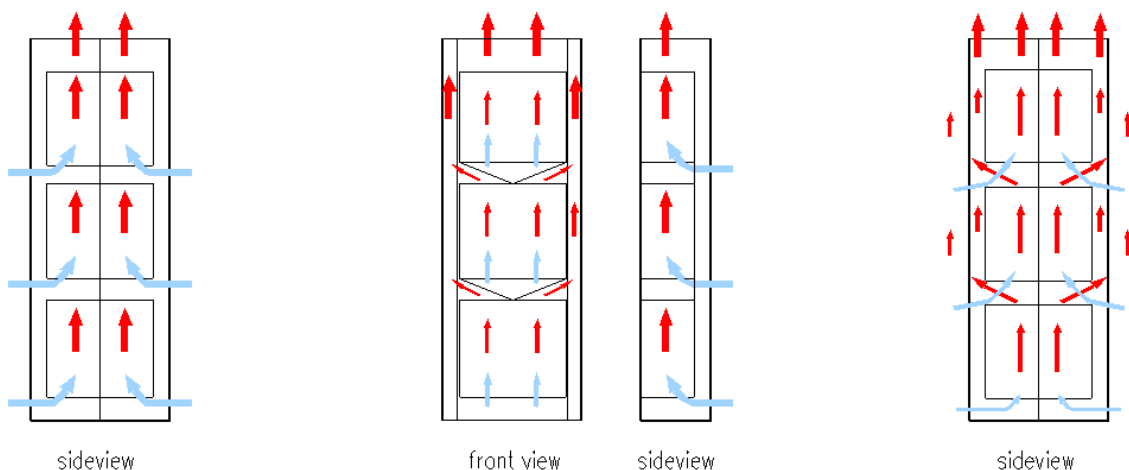

Figure B.3.1: ETSI 300 mm ARCM solution

For ETSI 300 mm ARCM, we introduce three different types of current thermal solutions, shown in figure B.3.1, which all were designed for back to back installation in CR.

In the first solution, fresh air enter the ARCM from the front or bottom, pass the three stages of subracks, were heated and exit from the top of the cabinet. Different types of subracks might be integrated into same ARCM, the top subrack always meets great thermal challenge. Normally, PDU (Power Distribution Unit) will be located at the top of cabinet in cement floor central office, with increasing power density, the size of PDU also increases, it will block the air exit path.

In the second solution, fresh air enter the ARCM from the front or bottom of each subracks, were heated and exit from the side of the cabinet, eventually exit from the top of the cabinet by the air baffle. In this solution, the three subracks is more isolated than first solution, but, for EN 300 119-3 [i.5] compliant cabinet, the side air path is less than 50 mm, there will not be enough air volume for current fan capacity. To solve this problem, the cabinet need to be enlarged to 900 mm, which leaves the air path 200 mm width. Thus, the ARCM needs more space in the CO.

In the third solution, cold air enter the ARCM from the front or bottom of each subracks, were heated as separated by the air deflector and exit from the front of the cabinet. The cold air and hot air path were relatively separated in this solution. The main problem for this solution is front maintenance.

B.3.2 ETSI 300 ARCM in CO

Generally speaking, there are two arrangement types in CO for ETSI 300 mm ARCM.

In type I, 300 mm cabinets were installed back to back, lined up with 600 mm cabinet, as shown in figure B.3.2a. In the central office, hot aisle and cold aisle are separated, for back-to-back 300 cabinet, it is possible that air from hot aisle were sucked into the equipment. In some cases, cold air from the floor (non- cement) can be lead to the inlet of 300 cabinet, but, it still can be mixed with the air hot.

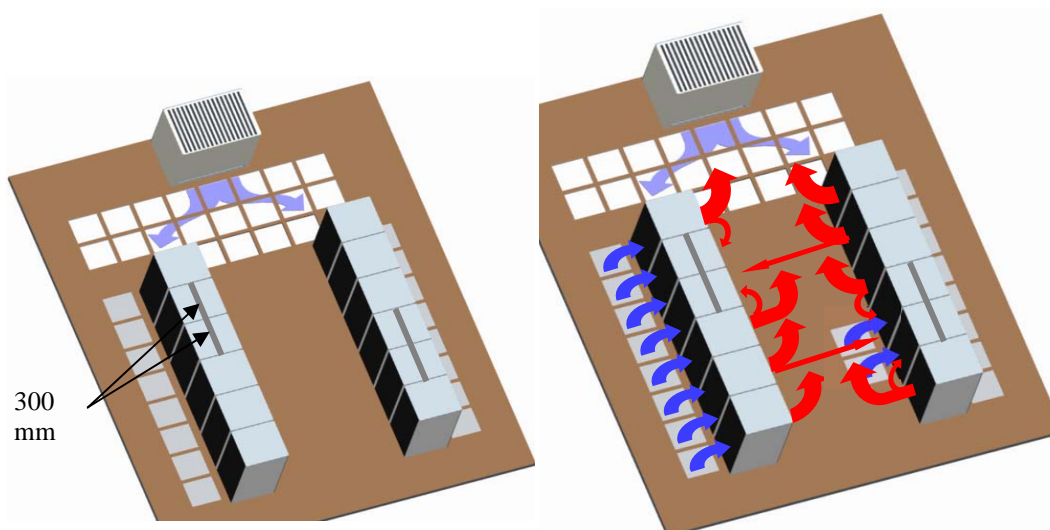

Figure B.3.2a: 300 mm cabinet in same line with 600 mm cabinet in central office

In type II arrangement, 300 mm cabinet and 600 mm cabinet are installed in different lines in CO, as shown in figure B.3.2.b. In the real case, the hot air exit from the top or front of the cabinet will mixed with the cold air which should enter the cabinet, especially in the top subrack, it is hard to solve the thermal problem.

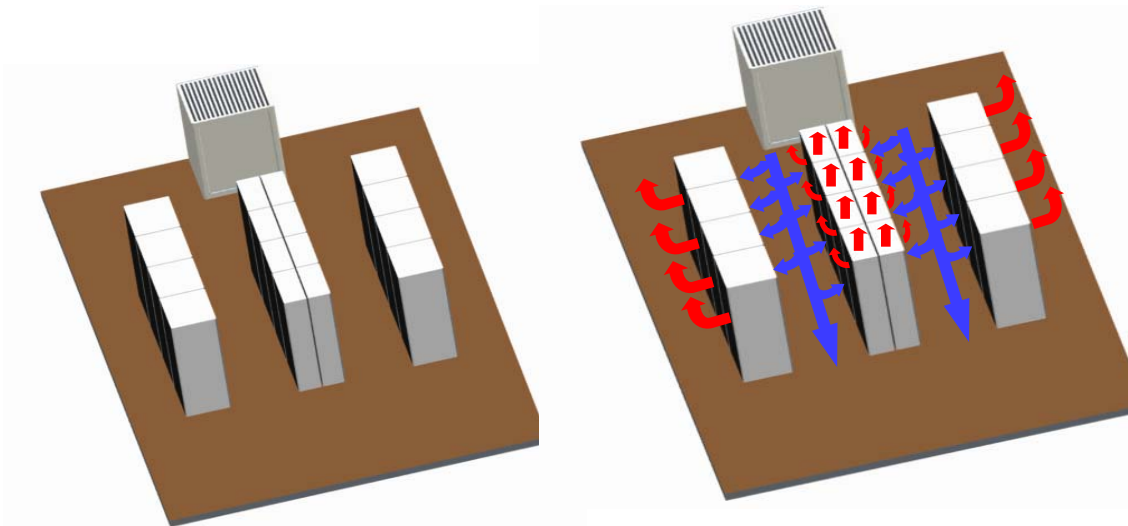

Figure B.3.2.b: 300 mm cabinet in central office type II

B.3.3 Alternative ETSI 300 ARCM instalment in CO

Allowed some distance between the 300 mm cabinet, the hot air can be exit from the back of the cabinet, the hot air and cold air can be separated in CO with this arrangement, that means the CRAC can have higher efficiency; air path for three subracks are isolated, it is easier to solve the thermal problem especially for the top subracks. Hence more subracks can be integrated in the 300 mm cabinet, although there are limited distance between the cabinets, in the CO, for same space, more equipment can be installed.

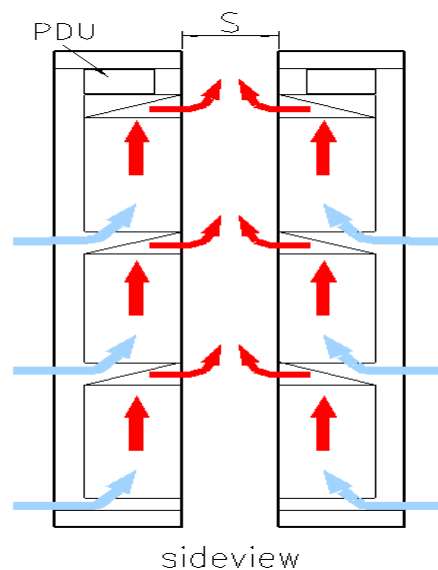

Figure B.3.3: ETSI 300 arranged with distance in CO

B.3.3.1 Simulation equipment configuration

This particular simulation was based on the configuration as shown in figure B.3.3.1, the simulation results are shown here for reference. There are three subracks integrated serially in 300 mm cabinet. For each subrack, there are top and bottom two fan trays.

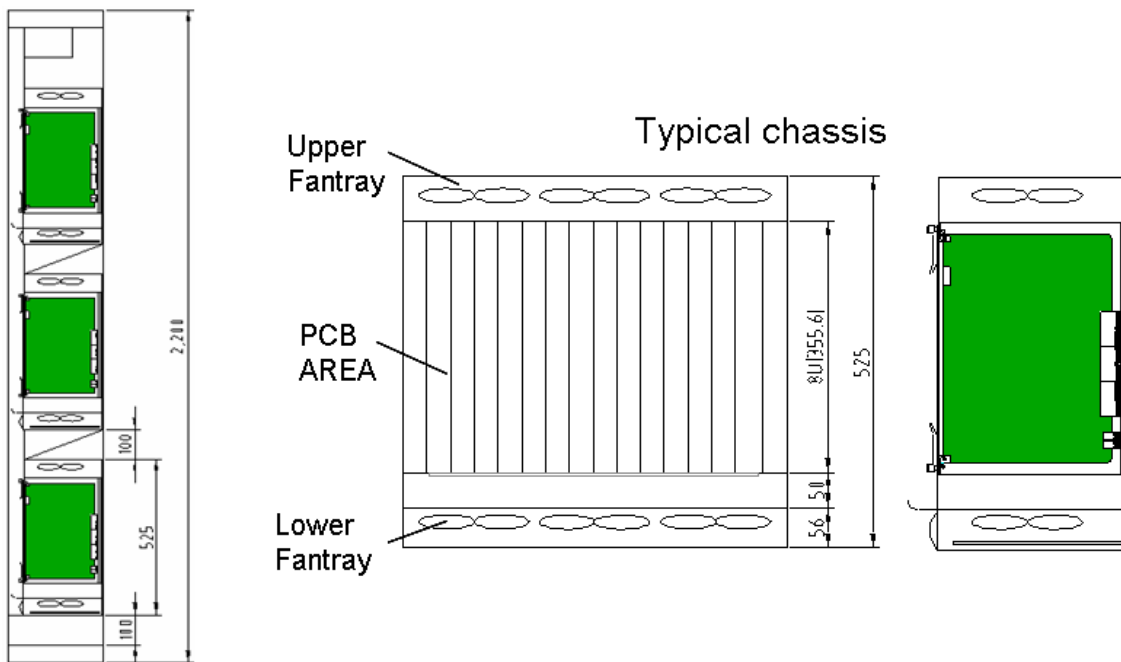

Figure B.3.3.1: Simulation configuration

B.3.3.2 Simulation results

Serial subracks and subracks with air exit at back of cabinet.

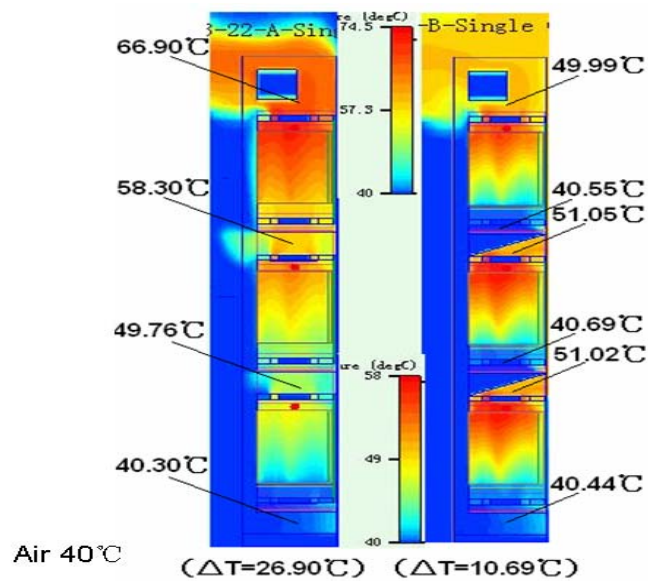

Figure B.3.3.2.a: Temperature profile of two different arrangement

In this clause, simulation result will be discussed. The work is based on the configuration shown as figure B.3.3.2.a In the left part, three subracks arranged in serials in the ARCM, the air enter the system from the bottom of cabinet, were heated by the three subracks and exit from the top of the cabinet; in the right part, since we allowed distance between two 300 cabinet, ($s=200$ mm), each subracks has its own cold air entry from the bottom and hot air exit from the back. From the temperature profile, we can clearly notice that the cabinet arrangement with distance has much smaller air raise ($dt = 10,69$ °C vs. $dt=26,9$ °C)

Some analysis was done considering different of distance for the thermal performance. From the figure 3.3.2.b. From the curves, we noticed that the dt is close to stable when s is equal to 200 mm.

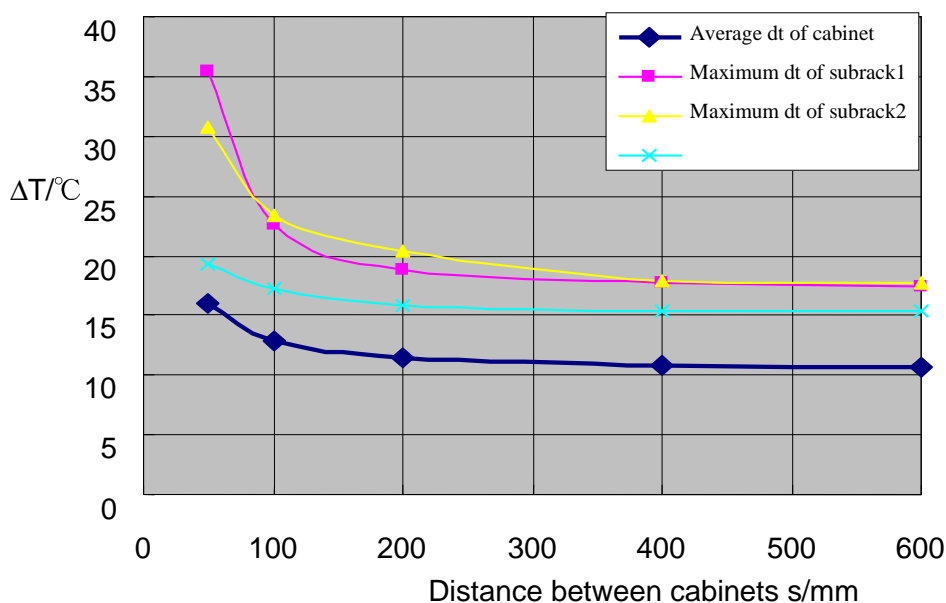

Figure B.3.3.2.b: Effect of distance between two racks

B.3.3.3 Proposed CO arrangement

IA 300 mm cabinet in serial arrangement back to back and with 200 mm distance is proposed as shown in figure B.3.3.3.

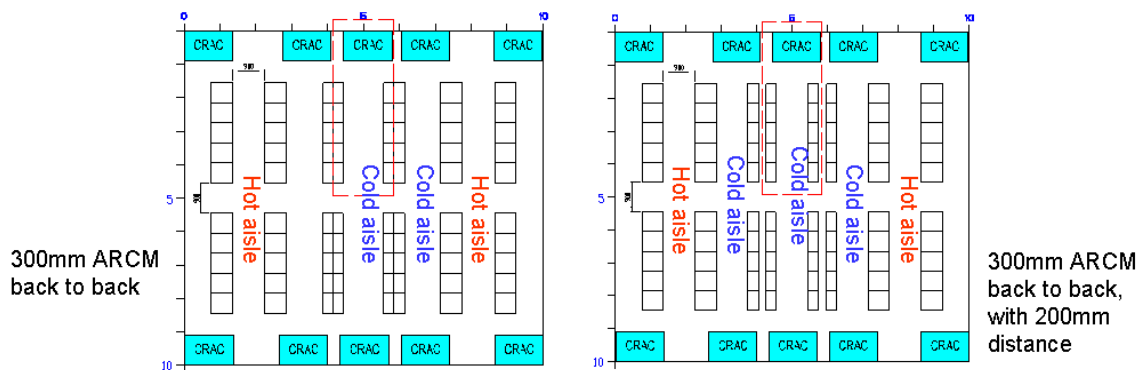

Figure B.3.3.3: Different 300 mm ARCM arrangement in CO

The simulation was based on central office (10 m × 10 m), as assume all the 300 mm ARCM has power 7 500 W 3 × 2 500 W.

The CO heat load:

- 6 columns in the CO, 10 600 mm cabinet per column, 20 300 mm cabinets per column.
- 7,5 kW per each 300 mm cabinet heat load in CO is 300 kw(4 × 10 × 7,5 kW);
- 9 kW per each 600 mm cabinet heat load in CO is 360 kw(4 × 10 × 9 kW);
- CO environmental heat load coefficient: 0,12~0,18×10×10 kW ; total heat load 672 kW~678 kW;

HVAC summary:

- There are altogether 10 AC units arranged for every equipment columns.
- Each AC units has cooling capacity 67,2~67,8 kW; (Emerson CM-80A).
- AC data: dry bulb temperature: 24 °C, relative humidity 50 %, heat capacitance 73,3 kW, air volume 16 560 m3/h.
- Cold air from AC: 15 °C.

In this simulation, the equipments inside the dash line are considered. The ARCM back to back with three subracks in serials and ARCM with distance 200 mm were investigated.

B.3.3.4 300 mm ARCM in CO simulation

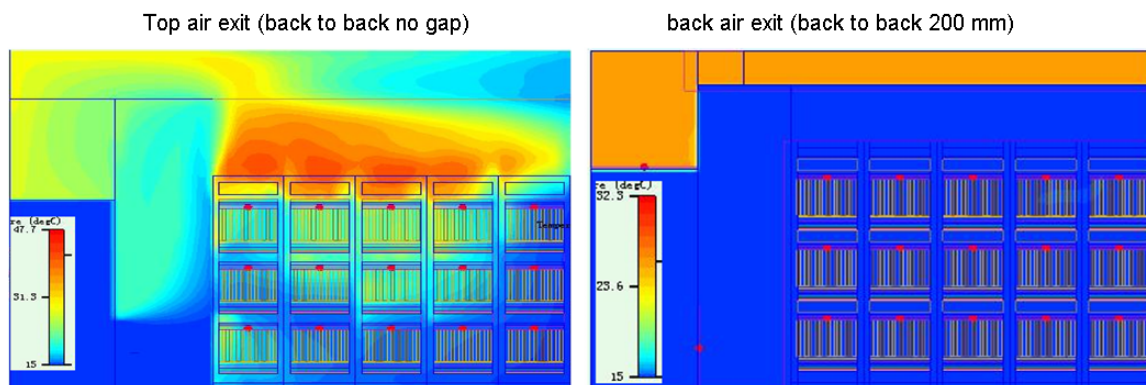

Figure B.3.3.4a: ARCM arrangement in CO

The simulation result, showed that with same CRAC air volume, and same AC air temperature, the top air exit arrangement has much higher temperature increment per ARCM than the back air exit arrangement. (The system temperature increase reduced 14,68), that means the CRAC's efficiency increased around 60 %. With limited distance between two racks, the single ARCM take only 0,06 m² more space.

	System DT	Air volume in ARCM	Air volume in CRAC	CRAC air return temp
Top air exit	25,44 °C	5 430 CFM	13 660 CFM	25,63 °C
Back air exit	10,76 °C	13 536 CFM	13 660 CFM	25,65 °C

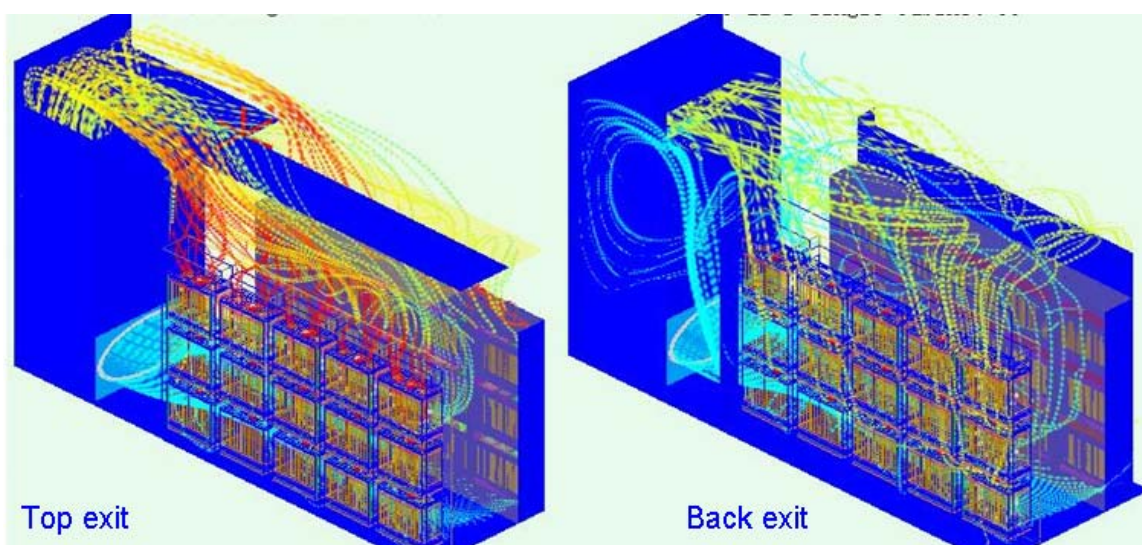

Figure B.3.3.4b: ARCM arrangement in CO

In the top exit arrangement, the cabinet air exit temperature is 40,44 °C, CRAC returning air temperature 25,63 °C, outlet air temp at 15 °C, that indicates lots of out let cold air from CRAC mixed with the exhausted hot air from the ARCM, then was sucked into the CRAC. With CRAC air volume 13 600 CFM, only 5 430 was utilized by cabinet, the efficiency is only 40 %. For most of equipment in the CO, the suitable working temperature is around -5 °C ~ 45 °C, the air temperature increase through the equipment should be controlled below 20 °C. To maintain this working environment, make the $dT < 20$ °C, we can either down grade the equipment performance (which is normally un-acceptable), or, reduce up to half of the subracks or boards in the ARCM. To achieve the same performance, 50 % more ARCM are needed, that means, 50 % more CO space are required.

In the back air exit arrangement, the cabinet air exit temperature is 25,76 °C, CRAC returning air temperature 25,65 °C, outlet air temp at 15 °C, that indicates very few cold air from CRAC mixed with the exhausted hot air from the ARCM, the cold air and hot air are successfully isolated by the hot aisle and cold aisle in the CO. With CRAC air volume 13 600 CFM, 13 536 cfm was utilized by cabinet, the efficiency is nearly 100 %. As we already know that the air temperature increase through the equipment should be controlled below 20 °C, which is much higher than the 10,76 °C increment in this case, that indicates we can increase the CRAC air temperature to 30 °C, which will reduce the total power consumption of CO.

Different central office has totally different facilities and equipments. Method of integration and installation ARCM need to be carefully considered related to the detail circumstances. The best solution is based on both energy saving and equipment performance.

If there are thermal issues in a 600 mm × 300 mm rack, another possible solution is to use the 600 mm × 600 mm rack and maintain the installation as back to back racks. The proposal to install 600 mm × 300 mm racks with 200 mm space from the back side will impose to install the 600 mm × 300 mm racks in dedicated rows and no more in combination with the 600 mm × 600 mm racks. Then the proposal is to keep the installation practices as defined in the present document. The 300 mm racks with 200 mm gap proposal give end user another option of equipment arrangement and have its advantage especially in new CO/DC or remodelling of old exist CO/DC.

Annex C: Bibliography

- IEC 60721: "Classification of environmental conditions".
- ETSI EN 301 169-1: "Equipment practice; Engineering requirements for outdoor enclosures; Part 1: Equipped enclosures".
- ETSI EN 301 169-2: "Equipment practice; Engineering requirements for outdoor enclosures; Part 2: Unequipped enclosures".

History

Document history		
V1.1.1	June 2004	Publication
V1.2.1	February 2010	Publication