

**Emergency Communications (EMTEL);
Basis of requirements for communication of individuals
with authorities/organizations in case of distress
(Emergency call handling)**



Reference

RTR/EMTEL-00016

Keywordsaccess, administration, disability, emergency,
priority call, regulation**ETSI**

650 Route des Lucioles
F-06921 Sophia Antipolis Cedex - FRANCE

Tel.: +33 4 92 94 42 00 Fax: +33 4 93 65 47 16

Siret N° 348 623 562 00017 - NAF 742 C
Association à but non lucratif enregistrée à la
Sous-Préfecture de Grasse (06) N° 7803/88

Important notice

Individual copies of the present document can be downloaded from:

<http://www.etsi.org>

The present document may be made available in more than one electronic version or in print. In any case of existing or perceived difference in contents between such versions, the reference version is the Portable Document Format (PDF). In case of dispute, the reference shall be the printing on ETSI printers of the PDF version kept on a specific network drive within ETSI Secretariat.

Users of the present document should be aware that the document may be subject to revision or change of status. Information on the current status of this and other ETSI documents is available at

<http://portal.etsi.org/tb/status/status.asp>

If you find errors in the present document, please send your comment to one of the following services:

http://portal.etsi.org/chaicor/ETSI_support.asp

Copyright Notification

No part may be reproduced except as authorized by written permission.
The copyright and the foregoing restriction extend to reproduction in all media.

© European Telecommunications Standards Institute 2010.
All rights reserved.

DECT™, **PLUGTESTS™**, **UMTS™**, **TIPHON™**, the TIPHON logo and the ETSI logo are Trade Marks of ETSI registered for the benefit of its Members.

3GPP™ is a Trade Mark of ETSI registered for the benefit of its Members and of the 3GPP Organizational Partners.

LTE™ is a Trade Mark of ETSI currently being registered

for the benefit of its Members and of the 3GPP Organizational Partners.

GSM® and the GSM logo are Trade Marks registered and owned by the GSM Association.

Contents

Intellectual Property Rights	5
Foreword.....	5
Introduction	5
1 Scope	7
2 References	7
2.1 Normative references	7
2.2 Informative references.....	8
3 Definitions and abbreviations.....	9
3.1 Definitions.....	9
3.2 Abbreviations	10
4 Description of the emergency call service.....	11
4.1 General description/provisions.....	11
4.1.1 User related requirements	12
4.1.1.1 Public Network Access Points	12
4.1.1.2 Public pay telephones.....	12
4.1.1.3 Other types of telephones:.....	13
4.1.1.4 Private Networks	13
4.1.1.5 Multipurpose facilities	13
4.1.2 Requirements applicable to the emergency call functionality of terminal equipment	13
4.1.3 Speech quality of emergency calls.....	13
4.1.4 Charge exemption for emergency calls.....	13
4.1.5 Ensuring emergency call conveyance	14
4.1.6 Assignment of emergency calls to the appropriate PSAP.....	14
4.1.7 Preventing effects of discrepancies in coverage	14
4.1.7.1 Radio Coverage Limit cases between mobile networks	14
4.1.7.2 International cooperation	14
4.1.7.3 Cordless technologies.....	14
4.1.8 Preventing network integrity or capacity failure	14
4.2 Recognition and treatment of emergency calls by the originating network	14
4.2.1 Emergency call-related information	15
4.2.1.1 Calling line number of the access at which the emergency call is made.....	15
4.2.1.2 Location information related to the origin of the emergency call	15
4.2.1.2.1 Use of a fixed line access for an emergency call	15
4.2.1.2.2 Use of a mobile phone for an emergency call	16
4.2.1.3 Identification of the mobile terminal equipment.....	16
4.2.2 Network identification	16
4.2.3 Minimum power supply for user accesses	16
4.2.4 Overdialling	16
4.2.5 Suppression of carrier selection/carrier preselection codes	16
4.2.6 Emergency calls from other countries	17
4.2.7 Routing of SMS complementing emergency calls while roaming:.....	17
4.2.7.1 General consideration.....	17
4.2.7.2 Consequence in the case of international roaming	17
4.3 Handling of emergency calls between networks	18
4.4 Providing termination of emergency calls to the PSAP	18
4.4.1 Features of the emergency control centres.....	18
4.4.2 Release of emergency calls/Call back of emergency calls.....	18
4.4.3 Temporary blocking of Emergency Calls from a particular source	18
4.5 Emergency call-specific functions for all involved networks	19
4.5.1 Priority of emergency calls	19
4.6 Network management support functions for delivery of Emergency calls to PSAPs.....	19
4.6.1 Monitoring of the lines and availability of the PSAPs.....	19
4.6.2 Diversion of emergency calls.....	19

4.6.3	Permanent availability	19
4.6.4	Security provisions at access to PSAPs	19
4.6.5	Release of resources to the PSAP when a call is transferred	19
5	European-wide interface between operators and public safety answering points	20
6	Special requirements when making emergency calls by disabled, elderly and young users.....	20
6.1	General	20
6.2	PSAPs Emergency control centres	20
6.3	Public telephones.....	21
6.4	Additional Information.....	21
7	Special requirements for emergency calls in a foreign language	21
8	Data protection	21
9	Future and other networks	21
Annex A:	Basic Architecture.....	22
Annex B:	Disabled, elderly and young users	25
B.1	General	25
B.2	People with disabilities.....	25
B.3	Senior Citizens	25
B.4	Young People	26
B.5	Terminal Issues	26
B.6	Network Issues	26
Annex C:	Bibliography	27
History	28

Intellectual Property Rights

IPRs essential or potentially essential to the present document may have been declared to ETSI. The information pertaining to these essential IPRs, if any, is publicly available for **ETSI members and non-members**, and can be found in ETSI SR 000 314: "*Intellectual Property Rights (IPRs); Essential, or potentially Essential, IPRs notified to ETSI in respect of ETSI standards*", which is available from the ETSI Secretariat. Latest updates are available on the ETSI Web server (<http://webapp.etsi.org/IPR/home.asp>).

Pursuant to the ETSI IPR Policy, no investigation, including IPR searches, has been carried out by ETSI. No guarantee can be given as to the existence of other IPRs not referenced in ETSI SR 000 314 (or the updates on the ETSI Web server) which are, or may be, or may become, essential to the present document.

Foreword

This Technical Report (TR) has been produced by ETSI Special Committee Emergency Communications (EMTEL).

The present document is the first of a set of deliverables covering the communication needs of individuals and authorities in emergency situations, as identified below:

- **TR 102 180 [i.19]: "Emergency Communications (EMTEL); Basis of requirements for communication of individuals with authorities/organizations in case of distress (Emergency call handling)";**
- TS 102 181 [i.20]: "Requirements for communication between authorities/organizations during emergencies";
- TS 102 182 [i.21]: "Requirements for communications from authorities/organizations to individuals, groups or the general public during emergencies";
- TR 102 410 [i.22]: "Requirements for communications between individuals and to authorities whilst emergencies are in progress".

Introduction

The provision of Emergency Telecommunications is one of the most important duties of a public authority towards individuals present on its territory. Individuals, Authorities and Emergency response teams therefore have a need for dedicated, high quality communication systems operating at all times.

In the past this area of communications has been developed, provided and organized by the national telecommunications operators and the national safety and security agencies/organizations. In today's deregulated and liberalized telecommunications market, operators of public telephone networks have the obligation to provide this type of communication under their regulation on a European and national basis.

At European Union level, a common emergency call number (112) is applied. In certain countries it may co-exist with former numbering codes maintained by the national authorities and dedicated to more specific usages or needs. The proposals of the present document are primarily focussed towards the deployment of a consistent service based on the 112 number; it is a matter of national decision and initiative to apply them for the other numbers in use for emergency calling.

The present document should be read as a contribution to the harmonization of the use of E112 by the emergency and disaster response agencies. Based on inputs from all parties in the Emergency Service User Community involved in providing such services, and after due adoption, the requirements expressed should be distributed to the relevant ETSI Technical Bodies, who are requested to take this material into account when amending existing, or drafting new, deliverables for services and systems to support Emergency Communications. But the present document can also be made available to other organizations and mainly at European Commission level as a contribution to their work, as the case may apply.

The present document catalogues the requirements on Emergency Call Handling as seen by the Emergency Service User Community. Clause 4 sets out the requirements on the emergency call service itself, including: service provision, end-user expectations and related requirements, terminal equipment, the call originating network, interconnection between networks, the functionality on the PSAP (Public Safety Answering Point), functionality on involved and transit networks, and network management requirements. Clause 5 outlines the benefits of a European-wide interface between operators and Public Safety Answering Points. Clause 6 lists the special requirements when making emergency calls by disabled, elderly and young users. Clause 7 refers to the need for special requirements for emergency calls in a foreign language. Where clause 8 quotes the data protection provisions in the case of an Emergency situation and clause 9 refers to the need for future considerations in further networks still to be defined. Clause 4 is the main clause describing the basic working of the service and its components, with a catalogue of the types of access to be considered and their special networking considerations.

Both the Directive 2002/21/EC [i.3] and the Commission Recommendation C(2003)2657 [i.2] of 25/07/2003 on the processing location information, related to the terminal through which an emergency call is made, in electronic communication networks for the purpose of location enhanced emergency call services set out recommendations and requirements which network operators, equipment manufacturers and emergency centres should take into consideration.

Additionally, the emergence and development of alternative offers based on technologies as VoIP (Voice over Internet Protocol) is creating critical situation linked to the definition of the service offered. There is a need to consolidate the comprehensive provision of the emergency call (including short numbering, adequate origin-dependent routing, no charge and transmission additional information) as a reference requirement in the planning of future systems.

Consideration is also given to the use of SMS, in conjunction with an emergency call, and the emerging applications which combine different technologies (e.g. Multimedia Message services or GPS).

1 Scope

The present document gives an overview of the requirements for communication from individuals to authorities and organizations in all types of emergencies. It collects operational and organizational requirements as a basis for a common 112 service, including location information (E112). Although many of the requirements collected from network operators, service providers (e.g. emergency response organizations) and users relate to national public policies and regulation, there are a number of service and technical aspects which are better dealt with on the European level to ensure harmonized access and services over Europe and effectiveness by user increased awareness by using standardized solutions.

The essence of an emergency call is to establish a direct and real time means of conversation between the calling party and an officer, in a Public Safety Answering Point, in charge of bringing assistance or organizing response. But the scope of the present document encompasses also various types of services that can bring an added value to this basic scenario or add new scenarios, such as transmission of data to extend the information made available to the PSAP's agent or to facilitate access of people suffering disabilities or impairments.

The present document also collects already established requirements for EMTEL and gives guidance on how to find the standardization work published or ongoing. The document also identifies the areas needing particular attention from the experts and refers to identified documents in preparation in SDOs (Standard Development Organizations).

The present document outlines the basis for technical, operational, organizational or regulatory requirements.

The present document is primarily applicable to ETSI technical bodies for the defining of services and specifying technical solutions.

Requirements for emergency calls of a private nature (e.g. vehicle/road assistance) and directed to an emergency service provider not being an emergency service provider recognized by a government are not covered by the present document.

It is anticipated that the present document will be maintained, by taking in line with developments at regulatory level and more specifically within the CoCom (Communication Committee for the Electronic Communications Directives) at the European Commission (EC) level.

2 References

References are either specific (identified by date of publication and/or edition number or version number) or non-specific. For specific references, only the cited version applies. For non-specific references, the latest version of the reference document (including any amendments) applies.

Referenced documents which are not found to be publicly available in the expected location might be found at <http://docbox.etsi.org/Reference>.

NOTE: While any hyperlinks included in this clause were valid at the time of publication ETSI cannot guarantee their long term validity.

2.1 Normative references

The following referenced documents are necessary for the application of the present document.

Not applicable.

2.2 Informative references

The following referenced documents are not necessary for the application of the present document but they assist the user with regard to a particular subject area.

- [i.1] ETSI TS 102 164: "Telecommunications and Internet converged Services and Protocols for Advanced Networking (TISPAN); Emergency Location Protocols [OMA-TS-MLP-V3-2-20051124-C]".
 - [i.2] C(2003)2657: Commission Recommendation of 25th July 2003: "Recommendation on the processing of caller location information in electronic communications networks for the purpose of location-enhanced emergency call services", published on O.J.E.U. L 189/49 the 29.7.2003.
 - [i.3] Directive 2002/21/EC on a common regulatory framework for electronic communications networks and services (Framework Directive).
 - [i.4] Directive 2002/22/EC on universal service and users' rights relating to electronic communications networks and services (Universal Service Directive).
 - [i.5] ETSI EG 202 116: "Human Factors (HF); Guidelines for ICT products and services; "Design for All"".
 - [i.6] ETSI ETR 333: "Human Factors (HF); Text Telephony; Basic user requirements and recommendations".
 - [i.7] ITU-T Recommendation V.18: "Operational and interworking requirements for DCEs operating in the text telephone mode".
 - [i.8] ETSI ETS 300 381: "Telephony for hearing impaired people; Inductive coupling of telephone earphones to hearing aids".
 - [i.9] ETSI ETS 300 488: "Terminal Equipment (TE); Telephony for hearing impaired people; Characteristics of telephone sets that provide additional receiving amplification for the benefit of the hearing impaired".
 - [i.10] ETSI TR 102 133: "Human Factors (HF); Access to ICT by young people: issues and guidelines".
 - [i.11] ITU-T Recommendation E.115: "Computerized directory assistance".
 - [i.12] ETSI TS 123 271: "Digital cellular telecommunications system (Phase 2+); Universal Mobile Telecommunications System (UMTS); LTE; Functional stage 2 description of Location Services (LCS) (3GPP TS 23.271)".
 - [i.13] CEN/CENELEC Guide 6: "Guidelines for standards developers to address the needs of older persons and persons with disabilities".
 - [i.14] ISO/IEC Guide 50: " Safety aspects - Guidelines for child safety".
 - [i.15] Directive 2002/58/EC of the European Parliament and of the Council of 12 July 2002 concerning the processing of personal data and the protection of privacy in the electronic communications sector (Directive on privacy and electronic communications).
 - [i.16] Void.
 - [i.17] Void..
 - [i.18] CGALIES outputs (Co-ordination Group on Access to Location Information by Emergency Services) served as a base for the EC-Recommendation.
- NOTE: Available at (<http://www.telematica.de/cgalies/>).
- [i.19] ETSI TR 102 180: "Emergency Communications (EMTEL); Basis of requirements for communication of individuals with authorities/organizations in case of distress (emergency call handling)".

- [i.20] ETSI TS 102 181: "Emergency Communications (EMTEL); Requirements for communication between authorities/organizations during emergencies".
- [i.21] ETSI TS 102 182: "Emergency Communications (EMTEL); Requirements for communications from authorities/organizations to individuals, groups or the general public during emergencies".
- [i.22] ETSI TR 102 410: "Emergency Communications (EMTEL); Basis of requirements for communications between individuals and between individuals and authorities whilst emergencies are in progress".
- [i.23] ETSI TR 102 445: "Emergency Communications (EMTEL); Overview of Emergency Communications Network Resilience and Preparedness".
- [i.24] ETSI TS 123 040: "Digital cellular telecommunications system (Phase 2+); Universal Mobile Telecommunications System (UMTS); Technical realization of Short Message Service (SMS) (3GPP TS 23.040)".
- [i.25] ETSI TS 124 008: "Digital cellular telecommunications system (Phase 2+); Universal Mobile Telecommunications System (UMTS); LTE; Mobile radio interface Layer 3 specification; Core network protocols; Stage 3 (3GPP TS 24.008)".

3 Definitions and abbreviations

3.1 Definitions

For the purposes of the present document, the following terms and definitions apply:

enhanced 112 (E112): emergency communications service using the single European emergency call number, 112, which is enhanced with location information of the calling user (see Commission Recommendation C(2003)2657))

emergency call: call from an individual who wants to reach the PSAP

emergency call facilities: emergency telephone stanchions/boxes, fire alarms, etc.

NOTE: These facilities are either publicly accessible, or located within private premises.

emergency call with SMS: emergency call complemented by SMS

NOTE: The purpose of the SMS is to convey context information or to help a communication with impaired people.

Emergency Control Centre (ECC): facilities used by emergency organizations to handle rescue actions in answer to an emergency calls

NOTE: A PSAP forwards emergency calls to the Emergency Control Centres.

emergency number: special short code(s) or number(s) which is used to place an emergency call

NOTE: The emergency number is used by the individual in need of assistance from the emergency services. There exist two different types of emergency numbers in Europe:

- 1) **European emergency number, 112:** the emergency number for pan-European access to emergency services and used, for example, in the European Union member-states, Switzerland and other European countries.
- 2) **National emergency numbers:** each country may also have a specific set of emergency numbers.

emergency response organization: e.g. the police, fire service and emergency medical services

emergency service: service, recognized as such by the Member State, that provides immediate and rapid assistance in situations where there is a direct risk to life or limb, individual or public health or safety, to private or public property, or the environment but not necessarily limited to these situations

NOTE: See Commission Recommendation C(2003)2657 [i.2].

individual: any person (resident, visitor, passer-by), present in the vicinity of an emergency situation (from the first notice till the complete clearance) and subject to be affected by it, but who has no identified role in the actions of rescue and of restoration of normal conditions

NOTE: Depending on his/her situation, the individual can send alerts or provide information to the emergency services, but in many cases is either passive or a potential victim.

location information: data enabling to know the geographic position of a terminal used by the calling party

originating network: portion of the communications network(s) that provides the connection of a user's equipment to the public communication services from which the emergency call was originated

overdialling: dial and send additional digits, beyond the normal/minimum length of a valid number, for example to obtain a special service required

NOTE: The extended Dialling string has to be entered within a specified time and processed without any intermediate dial-tone or announcements.

Public Safety Answering Point (PSAP): physical location where emergency calls are received under the responsibility of a public authority

NOTE: See Commission Recommendation C(2003)2657 [i.2].

user access: point of access to a telecommunication network where an emergency call can be requested

NOTE: This includes public telephones and "emergency call facilities".

3.2 Abbreviations

For the purposes of the present document, the following abbreviations apply:

CEN	Comité Européen de Normalisation
CENELEC	Comité Européen de Normalisation ELEctrotechnique
CGALIES	Co-ordination Group on Access to Location information by Emergency Services
CLI	Calling Line Identity
CoCom	Communication Committee for the Electronic Communications Directives
EC	European Commission
ECC	Emergency Control Centre
EMTEL	EMergency TELcommunications
ETS	ETSI Technical Specification
GAD	(Universal) Geographic Area Descriptio
GPS	Global Positioning System
GSM	Global System for Mobile telecommunications
HF	Human Factor
ICT	Information and Communication Technologies
IEC	International Electrotechnical Commission
IMEI	International Mobile Equipment Identifier
IP	Internet Protocol
IPR	Intellectual Property Right
ISO	International Organization for Standardization
LCS	LoCation Services
MMS	Multimedia message Services
MSC	Mobile Switching Centre
OJEU	Official Journal of the European Union
PBX	Private Branch Exchange
PLMN	Public Land Mobile Network
PSAP	Public Safety Answering Point

SIM	Subscriber Identity Module
SMS	Short Message Service
SMS-SC	Short Message Service Service Centre
TB	Technical Body
TCP	Transport Control Protocol
TE	Terminal Equipment
TISPAN	Telecommunications and Internet converged Services and Protocols for Advanced Networks
TR	Technical Report
UE	User Equipment
UMTS	Universal Mobile Telecommunications System
USIM	Universal Subscriber Identity Module
VoIP	Voice over Internet Protocol
VPLMN	Visited PLMN
VPN	Virtual Private Network
XML	eXtensible Mark up Language

4 Description of the emergency call service

4.1 General description/provisions

Directive 2002/22/EC [i.4] requires that in addition to any other national emergency call number specified by the national authorities all end users of publicly available telephone services have the possibility to call the emergency services free of charge by using the single European emergency call number "112". A more complete listing of the European Commission (EC) regulatory principles can be found at [i.14].

The objective of the requirement is to maximize the probability that a user will be able to make a basic telephone call to the appropriate emergency service whenever necessary without imposing undue constraints on terminals, networks or service providers, and to provide the emergency service with as much location information as reasonably possible. The scenarios in which this objective should be met will become increasingly complex due to factors such as:

- the introduction of new services including services that are backwards compatible with basic telephony;
- the development of both new special purpose terminals and the support of telephony on multi-purpose terminals;
- the provision of multiple different services and choices of service provider accessible (e.g. via carrier pre-selection) at a single network termination point.

To facilitate these regulatory principles, details of the requirements are provided in the following clauses.

Additionally, the commission recommendation C(2003)2657 [i.2]of 25/07/2003 recommends that the originating network should generate emergency call-related information and transmit this information together with the single European emergency call number "112".

Recommendations 4, 7 and 9 of commission recommendation C(2003)2657 [i.2]of 25/07/2003, are quoted below:

4. "For every emergency call made to the European emergency call number 112, public telephone network operators should, initiated by the network, forward (push) to public safety answering points the best information available as to the location of the caller, to the extent technically feasible. For the intermediate period up to the conclusion of the review as referred to in point 13 below, it is acceptable that operators make available location information on request only (pull)".
7. "All location information provided should be accompanied by an identification of the network on which the call originates".
9. "For each emergency call for which the subscriber or user number has been identified, public telephone network operators should provide the capability to public safety answering points and emergency services of renewing the location information through a call back functionality (pulling) for the purpose of handling the emergency".

In some cases, the service may be complemented by the transmission of information in the form of SMS. This information is not provided by the network and it is routed via a different path than the voice service. It should be noted that the SMS service has several limitations, such as the absence of guaranteed real time delivery. The use of SMS should therefore be considered for specific situations (e.g. users with special needs) where it could enhance the efficiency of answering services and rescue teams, but never replaces the basic voice communication.

Additionally to the previous features, the provision of data besides voice can increase the effectiveness of the whole rescue organisation. For example, accurate location information of the caller, derived from GPS integrated in mobile phone terminals, can be provided along with the voice call. This information combined at the PSAP with other Geographic Information Services can be used to display automatically maps or status of resources in the vicinity. Other examples of data that may complement the basic voice call include Multimedia message Services (MMS) can also be used to provide e.g. pictures or video of the field situation and of the victims.

Such services should not be considered at the first establishment of the emergency call, but for use in the exchange of informations which may take place between the PSAP (or the ECC) and the calling party just after or in continuation of the emergency call.

4.1.1 User related requirements

Users should be able to make a basic telephone call to an emergency service on any terminal (see annex C for HF requirements) that supports outgoing calls to publicly available telephone services unless the terminal is clearly marked, or its software operation clearly identifies it, as incapable of making such calls under normal or power failure conditions. It is important that users' reasonable expectations are met and that users are generally made aware of any limitations in access to emergency services so that:

- persons responsible for premises may make adequate alternative provisions;
- users do not waste time in an emergency call attempt.

4.1.1.1 Public Network Access Points

All telephony terminal equipment should have the ability to fulfil the user's need for an emergency call once it is positioned to access a public telecom network (of a compatible design).

Additionally, the network access point should enable the emergency call, even when:

- normal Originating Telecommunications Services have been barred (e.g. because of non-payment of bills);
- the equipment (e.g. the Universal Subscriber Identity Module (USIM) card in a mobile phone) is protected by an identification/authentication procedure, unknown to the user in advance;
- the individual using a mobile phone for an emergency call is outside the coverage area of his/her home network, provided that the area is covered by another mobile network operator and that the mobile phone is technically compatible with the alternate network;
- the individual using a cordless phone for an emergency call is outside the coverage area of his/her home base station, provided that the area is covered by another base station belonging to the same or to a different network operator and that the cordless phone is technically compatible with the alternate base station.

All cases of national roaming scenarios are covered by national regulatory requirements and legislation.

It should be possible to make emergency calls all free of charge and without having to use any means of payment.

4.1.1.2 Public pay telephones

Directive 2002/22/EC [i.4] requires that it be possible to make emergency calls from public pay telephones using the single European emergency call number "112" and other national emergency numbers, all free of charge and without having to use any means of payment.

4.1.1.3 Other types of telephones:

It should be possible to place easily and without any barring conditions an emergency call from all types of telephones that have access to the public network (public telephones, dedicated call post with voice application, private coin and card payphones).

Easiness consist in the following characteristics: free of charge, direct dialling of "112" emergency number, no need of coin or means of payment to initiate the call, no need of operator assistance or language assistance.

4.1.1.4 Private Networks

Emergency calls from private networks can be routed to the public network. It is recommended that from private networks the emergency number can be dialled without any prefix.

When external assistance is required an emergency call should be forwarded to the PSAP or the corresponding emergency control centre.

This includes phones in public places where users require to be able to make emergency calls, free of charge and without having to use any means of payment.

Location information within a private network should be made available when possible and comply with the requirements of the corresponding emergency authorities in the country/area, in which the site or premises of the company are installed. For large private networks (covering several countries or even continents), attention must be paid to the fact that this requirement may be of importance when designing the architecture of the private network.

4.1.1.5 Multipurpose facilities

For multipurpose call facilities (e.g. customer assistance for vehicles and accidents) functionality should separate the operation modes in order to avoid unjustified calls to public emergency services.

4.1.2 Requirements applicable to the emergency call functionality of terminal equipment

Voice communication terminal equipment should be designed in such a way that emergency calls should be possible even if the terminal has a PIN-coded lock of the keypad. The requirement of this keypad over-ride is in accordance with national regulations. No terminal equipment feature should prevent an emergency call from being made. It is recommended to consider the operation of terminals connected to the fixed network in the case of mains power failures.

Provision of a user record allowing for precise location identification by cordless terminals connected to a visited base station of a fixed-line network similar to those available in a mobile terminal USIM card should be considered (see clause 4.2.1.2.1).

4.1.3 Speech quality of emergency calls

Where the network is not operating under abnormal conditions as a result of a disaster, the speech quality of emergency calls should not be worse than the user of a basic telephone service would experience on the majority of their calls.

Where the service provider normally provides enhanced speech quality above that of a basic telephone service, e.g. wideband speech, there is no obligation to provide the enhanced quality on emergency calls.

Where the network is operating under abnormal conditions, as a general principle, if a trade-off exists between speech quality and connectivity, connectivity should be given priority, and intelligibility should be given priority over other aspects of speech quality.

4.1.4 Charge exemption for emergency calls

Emergency call services should be free of charge and possible without the calling party using any means of payment.

4.1.5 Ensuring emergency call conveyance

Network operators should make every reasonable effort to ensure the answering, inter-network forwarding and termination of emergency calls, including in exceptional circumstances such as insolvency, crises, catastrophes, etc.

4.1.6 Assignment of emergency calls to the appropriate PSAP

Nominated PSAP of the emergency organizations deal with emergency calls from defined geographic areas. Emergency calls should be routed to, and handled within, the appropriate PSAP.

There should be an unambiguous mapping between the location of the terminal used for an emergency call and the PSAP responsible for the appropriate area.

This mapping should be prepared and kept up-to-date by the emergency control organization/authority and should be provided to all related telecommunications service providers.

More informational material can be found in CGALIES: <http://www.telematica.de/cgalies/> [i.18].

4.1.7 Preventing effects of discrepancies in coverage

4.1.7.1 Radio Coverage Limit cases between mobile networks

Due to physical uncertainty and variations of radio coverage limits there are border effects where an emergency call can not be routed to the geographically assigned PSAP. Attention should be given to all parties involved, and more specifically operators, when designing the network to limit the occurrence of such cases. Where this case occurs, cooperation of PSAP should be applied and organized as appropriate.

4.1.7.2 International cooperation

A situation similar to that described in clause 4.1.7.1 may appear near country borders: Cross-border emergency call handling requires international cooperation among emergency organizations of neighbouring countries.

4.1.7.3 Cordless technologies

Situation similar to those described in clauses 4.1.7.1 and 4.1.7.2 may be applicable as well to cordless technologies that use fixed-line networks.

4.1.8 Preventing network integrity or capacity failure

Access to the emergency services should be provided at a very high level of reliability and availability for the individual. Among various options, which are the analysed in TR 102 445 [i.23], authorities can assign to each PSAP a secondary (or even tertiary) PSAP, that can receive rerouted or overflowed traffic in case of any failure or congestion, as a back-up resource.

In such situations, the previous clauses should still be observed, and applied pending upon the organization agreed between authorities and operator.

4.2 Recognition and treatment of emergency calls by the originating network

Each originating network should be able to recognize emergency calls by means of the emergency call number "112" in addition to the local national emergency numbers valid in the originating network.

4.2.1 Emergency call-related information

In order to help the operations of the emergency services each emergency call should be accompanied with information that is described in clauses 4.2.1.1 to 4.2.1.3.

This information may either arrive at the PSAP at the same time as the emergency call or be available for retrieval on demand from the PSAP during the call. The generation and transmission of the information should not significantly delay the answering of the emergency call. Transit networks over which an emergency call is routed to a PSAP should forward this information in a transparent mode.

More informational material can be found in CGALIES <http://www.telematica.de/cgalies/> [i.18].

4.2.1.1 Calling line number of the access at which the emergency call is made

The originating network should transmit the Calling Line Identity (CLI) number of the access at which the emergency call is made to the PSAP together with the emergency call. The PSAP/Emergency Control Centre (ECC) should be able to return a call to the number in the CLI.

If the access at which an emergency call is made has the feature to transmit a number specified by the user in addition to the user access number (Two Number Delivery Option, e.g. in the case of PBX's (Private Branch Exchanges)), the originating network should transmit both call numbers to the PSAP and these numbers should not be changed by any transiting network.

In cases where emergency calls are made from mobile phones operated without a USIM card the CLI cannot be determined and transmitted to the PSAP by the originating network. In countries where this is authorized, in this scenario, the originating network should provide alternative information to the PSAP (see clause 4.2.1.3).

4.2.1.2 Location information related to the origin of the emergency call

Each emergency call should be accompanied with location information that facilitates for the PSAP agent the determination of the origin of the call at the time of calling. This information may be a geographical address or a set of geographical co-ordinates. The information should be accessible by the PSAP agent via a standardized interface after the initial contact is made. Location information should be accessible for as long as the emergency lasts.

NOTE 1: This information is required and has importance in the case of co-ordinating disaster relief. The impact this requirement has on the Network operator may vary on a national basis. The PSAP/ECC may only make requests for Location information in conjunction with an emergency call.

Typically, location information is based on the CLI received with the call for wireline networks, and on the geographical co-ordinates of the terminal used wireless networks. For roaming cordless terminals used for an emergency call, the home base station CLI, on which the terminal is connected at the moment of the call, may be desirable.

NOTE 2: Due to the support for Number portability or the inter-working with VoIP services determining location information solely from the CLI may be impossible with some database arrangements, where the interrogation of the data is dependant on the network operator's database requested.

4.2.1.2.1 Use of a fixed line access for an emergency call

For determining the location information for an emergency call through a fixed line access the site code of the access (e.g. geographical address of the access), which is stored in the network operator's customer database can be used. Specifications should exist for both:

- a push scheme, the address is automatically pushed with the initial call to the PSAP together with the CLI;
- a pull scheme, the PSAP agent should be able to access during the call a database using the CLI and preferably the protocol defined in TS 102 164 [i.1] or the ITU-T Recommendation E.115 [i.11] query.

Cordless terminals roaming for emergency call from their Home base station to a Visited base station when the home base station is not operational due to the emergency event should provide their home base station's CLI. Provision of two clearly distinguished sets of CLI+address should be considered. For the push scheme provision of information by the terminal originating the call may be considered.

NOTE: A pull scheme in the case of multiple carriers may require an Emergency centre to determine which location database to query; alternatively one option is to replicate data between databases.

4.2.1.2.2 Use of a mobile phone for an emergency call

The location information when a mobile phone is used for an emergency call should be specified for both:

- a push scheme, where the location information is automatically pushed with the initial call to the PSAP together with the information contained in the CLI field;
- a pull scheme, where the PSAP agent should be able to access a database with the relevant data, during the call and by using the CLI and preferably the protocol defined in TS 102 164 [i.1] or the TS 123 271 [i.12] query.

In cases where emergency calls are made from mobile phones operated without a USIM card, in countries where this is authorized, the originating network should provide location information to the PSAP/Emergency Control Centre in a Push scheme.

As all mobile networks support the transmission of Short messages (SMS) and considering that SMS can be transmitted also during an active voice call (though at reduced speed), it is possible for the emergency caller to send SMS with information that may be useful to the PSAP such as circumstances of the emergency, location, the status of the calling party and so on. Considering the function of a PSAP, the primary requirement is a voice communication ensuring an immediate contact and handling of the call. The SMS is only a complement to this voice communication and the nature of the data should be specified in relation to the enhancement of the emergency services in a specific context (e.g. road traffic, bearers with disabilities).

4.2.1.3 Identification of the mobile terminal equipment

When emergency calls are made from mobile phones operated without a USIM card, in countries where this is authorized, a CLI cannot be determined by the originating network. In this situation as an alternative, an equipment identity number (e.g. IMEI) may be transmitted by the originating network, subject to national legislative requirements.

This is conducive to misuse of the PSAP.

4.2.2 Network identification

With reference to Recommendation 7 (see clause 4) from the European Commission, all networks should transmit their network identification to the emergency control centre in a standardized way.

4.2.3 Minimum power supply for user accesses

If feasible, fixed network operators should provide a minimum power supply at their network termination points. This minimum power supply should enable telephone terminal equipment connected to the network termination point to be operational in the case of a local power failure for the placing of an emergency call.

4.2.4 Overdialling

The differences are observed within Europe as regards national regulations, numbering plans and switching equipment.

The issues linked with overdialling appear therefore as a national matter.

4.2.5 Suppression of carrier selection/carrier preselection codes

Carrier selection and carrier preselection codes generated in conjunction with emergency call numbers should not be taken into account. The emergency call has to be routed to the responsible PSAP corresponding to the actual origin of the call in all cases.

4.2.6 Emergency calls from other countries

In principle, "112" and other emergency calls should be terminated in the country of origin.

Technical Exceptions can appear:

- for calls originated in mobile networks, see clause 4.1.7;
- for calls originated in fixed networks, and where the following conditions are met, see clause 4.1.7:
 - use of a cordless handset, the base home station of which is connected to a foreign country wireline network;
 - the normal operation is based on a roaming feature, which is temporarily non-operational due to the emergency event; therefore the call is routed on this wireline network.

In such cases the calling terminal should indicate this special situation, if technically feasible with automatic location reporting.

Situations exist that this principle may become difficult to meet, these require further study. Actions may result in responsibilities on the private supporting network:

- Nomadic use of IP Telephony.
- IP VPN (Internet Protocol based Virtual Private Network) VoIP calls.
- Corporate and VPN networks.
- Satellite telephones.

4.2.7 Routing of SMS complementing emergency calls while roaming:

In addition to previous statements (see point 4) on the limitations of the SMS service in relation to the requirements of rapid delivery and bilateral real-time exchange, this clause draws attention on routing issues.

4.2.7.1 General consideration

Voice emergency calls are always routed to the local emergency service in the country where the Emergency voice call was made. On the other hand Short messages are routed to the subscriber's home PLMN and will be stored in the subscriber's home SMS-SC for onward routing to the intended destination. It is therefore necessary to align the SMS Emergency Message handling and Routing with that of the corresponding Voice communication.

The procedure for this is as follows:

- An Emergency mobile originated Short Message should be intercepted by the serving mobile network (i.e. the mobile network to which the sender's mobile is attached). The serving network should then route the Short Message to its own SMS-SC for onward routing to a local emergency service or route it directly to a local emergency service.

4.2.7.2 Consequence in the case of international roaming

If a mobile subscriber has roamed to another country, then

In order for the serving network to specifically identify an Emergency Short Message it will need to inspect the Short Message Destination Address, see [i.24]. The serving network should contain a list of predefined SMS Destination Addresses. For example, it is likely that an Emergency Short Message will use a "short code" as its Destination Address such as 112, 999, 911, etc., in line with the commonly recognised Voice Emergency Call numbers.

The serving network would be required to check if a Short Message Destination Address matches any of the emergency "short codes" and if so, to route the short message to the local emergency service either directly or via the serving networks SMS-SC. If there is no match, then the Short Message would be routed to the SMS-SC indicated in the Short Message Protocol Data Unit (see [i.24]). To improve the efficiency of the procedure, the local Emergency SMS-SC addresses could be downloaded from the VPLMN when the UE registers with the VPLMN; this may require the development of a procedure similar to that of TS 124 008 [i.25] applied for the downloading of local emergency short codes.

4.3 Handling of emergency calls between networks

If the originating network is not connected directly to the PSAP, a transit network is used between the two. For example, to route the call towards the termination network a specific routing number(s) is used. This number may identify the responsible emergency service for a specific area.

In case of the transfer of the emergency call from the originating network towards another network (transit, termination) this number has to be inserted by the originating network as the destination number.

The transit network should forward/transfer the emergency call received from the originating network together with the call-related additional information (except location information using retrieval/pull mode, see clause 4.2.1) immediately and without modification to the PSAP.

4.4 Providing termination of emergency calls to the PSAP

Any network to which a PSAP is directly connected should deliver the emergency call to the PSAP together with any related data, without undue delay or modification.

If the appropriate PSAP is not reachable, the call should be forwarded to the alternative PSAP (see clause 4.1.8).

PSAPs/Terminating networks should meet the functional requirements as detailed in clauses 4.4.1 to 4.4.3.

The interface at the PSAP private branch exchange for voice calls should be the same whichever the type of the emergency call (basic or with SMS).

4.4.1 Features of the emergency control centres

PSAPs and ECC should be provided with access to all of the CLI related information.

More informational material can be found in CGALIES <http://www.telematica.de/cgalies/> [i.18].

4.4.2 Release of emergency calls/Call back of emergency calls

It should be possible for only the PSAP/ECC to release an emergency call relationship in the network.

NOTE: It is observed that in many networks (e.g. mobile) these possibilities are not available.

It should be possible for the PSAP/ECC to call back an emergency call relationship in the network, where the calling Id can be identified.

4.4.3 Temporary blocking of Emergency Calls from a particular source

The PSAP should have the possibility to deliberately release/block repeated nuisance call attempts to the emergency telephone service from a particular source, see clause 4.1.1.1. This request may be relayed to the network where the nuisance call attempts to the emergency telephone service originate.

NOTE: This feature may not be supported in all countries.

4.5 Emergency call-specific functions for all involved networks

4.5.1 Priority of emergency calls

All network operators should give priority to emergency calls over all other calls. This priority should be maintained across public telecommunications networks, but does not imply a privilege of pre-emption.

In case of fixed-line networks priority should be given from the network access point from which the emergency call is made to the network termination point/PSAP.

In case of emergency call facilities and publicly available telephones, priority should be given from the terminal equipment from which the emergency call is made to the network termination point/PSAP.

In case of mobile networks priority should be given from the MSC to the network termination point/PSAP. Priority may include the air interface, where a different scheme is available.

Private networks should also give priority to emergency calls.

4.6 Network management support functions for delivery of Emergency calls to PSAPs

4.6.1 Monitoring of the lines and availability of the PSAPs

Transmission lines over which emergency telephone services are connected should be available without restriction. The terminating network and the PSAP permanently monitor the functionality and transmission quality of the transmission lines. Technical modifications and maintenance should not impair emergency telephone lines to the PSAP. If the quality falls below a minimum standard the network and PSAP should deactivate the access and check the availability and quality of the connection. Any such deactivation should not affect any call in progress.

4.6.2 Diversion of emergency calls

If a network access to a PSAP or a PSAP is deactivated or out of order the network should be able to divert incoming emergency calls to back-up/alternate equipment, lines, network access or PSAPs. The network management organization should inform the PSAP operations staff of these back-up facilities and any modifications made.

4.6.3 Permanent availability

Network operators should maintain reserved capacity to ensure termination of emergency calls to PSAPs and emergency control centres, including in situations where the standard capacity is fully utilized, subject to the nationally agreed Service Level Agreements.

4.6.4 Security provisions at access to PSAPs

The network operator should make reasonable provisions to mitigate against the impact of attack, either deliberate or accidental, to the access and core networks to which PSAPs are connected.

4.6.5 Release of resources to the PSAP when a call is transferred

It appears beneficial to the efficiency of the PSAP, to be able to release the capacities used for a call, when this call has been transferred (e.g. to an ECC, or an other PSAP).

5 European-wide interface between operators and public safety answering points

Europe would benefit from a common interface between public operators and the entry point of the PSAP. This would drive down on implementation cost and speed implementation. But perhaps more importantly, this would ensure a common data format is used across Europe for E112 including requirements related to future advanced applications.

The main requirements for such interface are as follows:

- Automatic terminal/network initiated real time location push to PSAP when the "112" emergency call is made.
- Possibility for location pull/information pull by PSAP/emergency service (e.g. of street address from operators' active database).
- Adequate level of privacy protection (override of user setting by authorized emergency authorities only and for as long as the emergency lasts).
- Flexibility for upgrade/able to include future (not fully specified) requirements (e.g. from roadside telematic applications as they may emerge).
- Build-in assurance that commonality at "information passing level" is perpetual.
- No reliance on the home network when roaming internationally and in cases where national roaming is possible.
- Based on future proof technology (e.g. Internet TCP/IP/XML for connecting to standard PC based product at PSAP level).

More informational material can be found in CGALIES <http://www.telematica.de/cgalies/> [i.18].

6 Special requirements when making emergency calls by disabled, elderly and young users

6.1 General

It is important that all users are able to make calls to the European emergency services with equal ease of access.

For this to be achieved it is likely that people with disabilities, older people and children will need special requirements for emergency call handling. Some special considerations applicable to these users are discussed in annex B. In order to make an emergency call service available to the widest population possible the practice of Design for All as described in the EG 202 116 [i.5] should be applied to the design of any emergency call system or terminal. Any standards for equipment or facilities used for an emergency call service should take into account the requirements set out in CEN/CENELEC Guide 6 [i.13] and those of ISO/IEC Guide 50 [i.14].

6.2 PSAPs Emergency control centres

All PSAPs, and Emergency Control Centres if they can be in contact with the individuals in need of assistance, should be equipped to deal with emergency calls from users with special communications difficulties. Operators should be specially trained to handle calls from users with poor speech or with intellectual or mental impairments.

As a minimum, equipment compliant with ETR 333 [i.6] and with ITU-T Recommendation V.18 [i.7] should automatically be available for such an incoming call. Call progress information should be available in ITU-T Recommendation V.18 [i.7] compliant form on all calls. All PSAPs (Emergency Control Centres if the case applies) should be able to handle calls incoming from text terminals as allowed in the country. These calls should be treated in all other respects as normal emergency calls.

Any SMS message addressed to the single emergency call number or any national equivalent should be given priority over other messages. Currently no such priority functionality has been standardized in the SMS specifications. Where appropriate, videophone facilities should be made available at all PSAPs (Emergency Control Centres if the case applies).

For receiving and handling the information contained in the SMS or in the data the PSAP will need specialised equipment and the staff should be trained to handle SMS. In this perspective prior registration of all potential users should be encouraged.

6.3 Public telephones

Special attention should be paid to make all public telephones wheelchair accessible and arrangements should be made to make their position identifiable to blind users. All public telephones should be provided with inductive coupling in accordance with ETS 300 381 [i.8] and should provide additional receiving amplification compliant with ETS 300 488 [i.9]. A reasonable proportion of public telephones should be provided with text phone facilities.

6.4 Additional Information

More information related to the specific requirements related to disabled, elderly and young users can be found in annex B.

7 Special requirements for emergency calls in a foreign language

Emergency organizations should take appropriate steps to ensure that emergency calls can be translated from a foreign language (e.g. by means of a conference call).

8 Data protection

PSAPS and Emergency Control Centres should adhere to the relevant data protection provisions.

In the case of an emergency, the PSAP and the emergency centre may override the settings of the user as regards the processing of his or her location. The technical means should be provided for such override.

Furthermore, in addition to organizational measures, the necessary technical safeguards will be introduced to secure that a location pull can only be carried out in relation to an emergency (e.g. CLI-based), and only for as long as the emergency lasts.

Special actions during emergency situations are allowed by Directive 2002/58/EC [i.15] of the European Parliament and of the Council of 12 July 2002 concerning the processing of personal data and the protection of privacy in the electronic communications sector (Directive on privacy and electronic communications).

9 Future and other networks

The present document is mainly based on the practical experience gained by using services available in a given technological environment. But it must be understood that requirements are independent of the technology. More specifically, services requirements that are met by the existing technology must be satisfied, as far as possible, in similar conditions by future public electronic communications networks, including terminals and applications, as regards the individual's behaviour, which should not be dependent on the technology.

Annex A: Basic Architecture

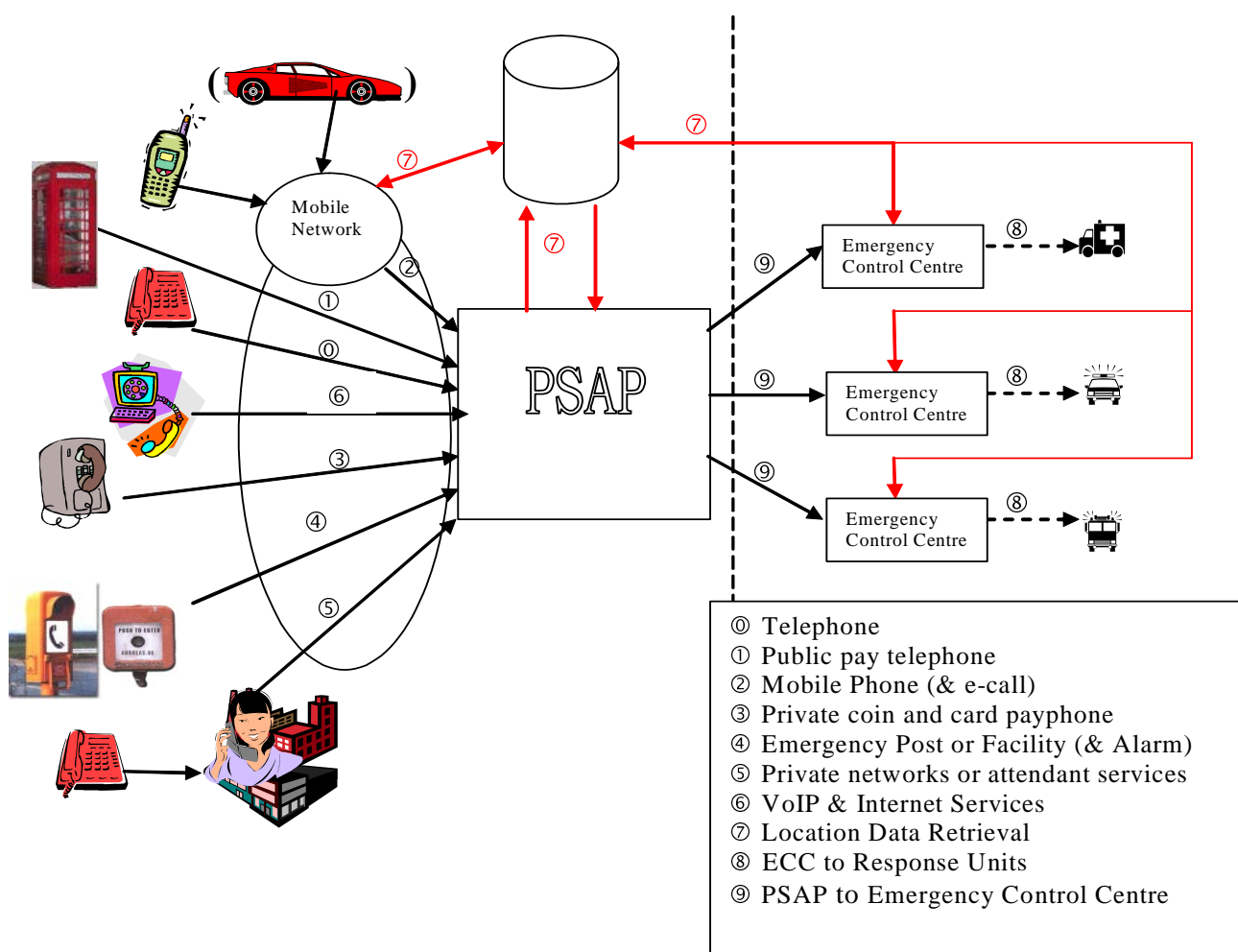

Figure A.1: Functional architecture

Figures A.2 and A.3 illustrate that the Functional Architecture can be mapped into two very different physical scenarios. The First showing a case where the PSAP and the Emergency Control Centre functionality are considered integrated into the same physical entity. The Second where the PSAP functionality is widely distributed and separate from the Emergency Control Centre functionality, and sits at the edge of the public network. In this case the network between the PSAP and the Emergency Control Centre is shown as a dedicated priority network, though physically there are today many ways that this could be achieved; e.g. by Leased Lines or Secure Virtual Private Networks (VPNs).

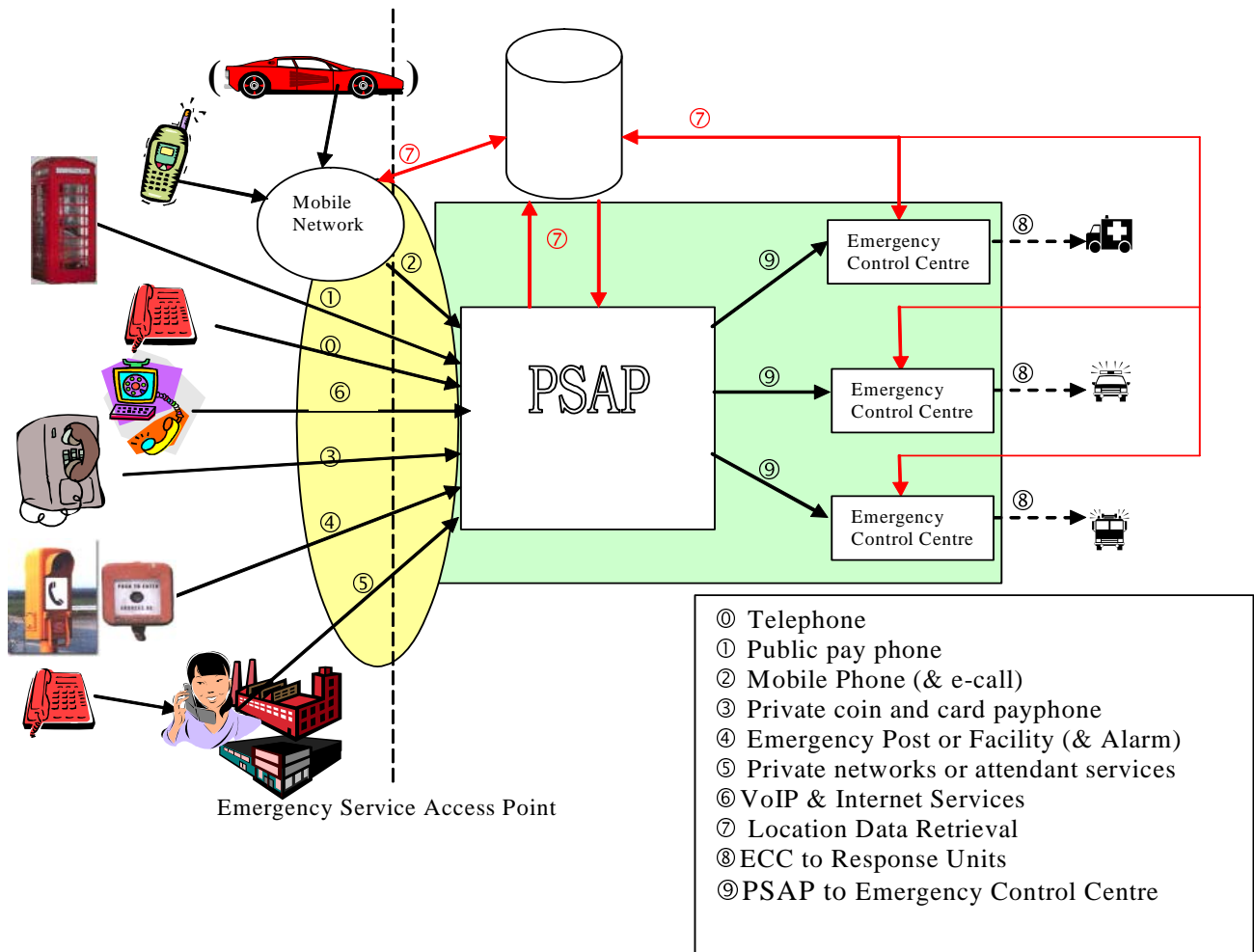

Figure A.2: Integrated PSAP and emergency control centre

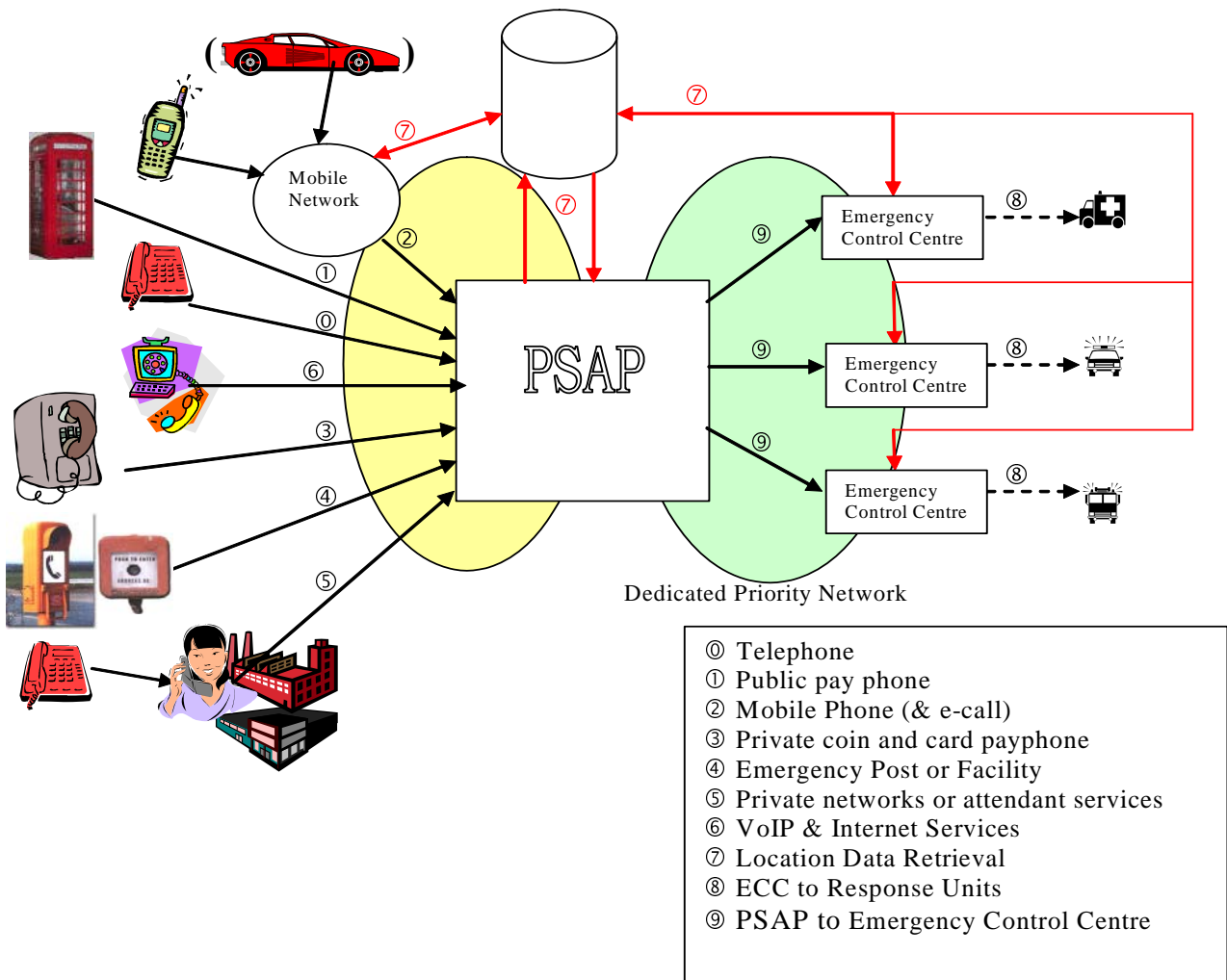

Figure A.3: PSAP on edge of the public network

Annex B: Disabled, elderly and young users

B.1 General

As noted in clause 6.1, there are some user groups who are likely to need special requirements for emergency call handling. These are very diverse and have very different requirements. They may be divided into three main categories, though these will often overlap:

- People with disabilities.
- Senior citizens.
- Young people (children).

Each of these categories may again be divided into sub-groups, all of which have very different requirements.

B.2 People with disabilities

Disabilities fall into three basic categories, which can be further sub-divided:

- **Sensory** impairments (sight, hearing, touch, taste/smell and balance).
- **Physical** impairments (speech, dexterity, manipulation, mobility and strength/endurance).
- **Cognitive** impairments (intellect, memory, language/literacy).

Characteristics of these disabilities and their relationship with ICT products and services are described in the EG 202 116 [i.5].

B.3 Senior Citizens

Senior Citizens can be divided into age groups with very different requirements (these age groups are very general as there are people aged 80 who function as well as most 60 year olds, and vice versa):

- **"Younger"** senior citizens (55 years to 65 years).
- **"Middle-age"** senior citizens (66 years to 80 years).
- **"Older"** senior citizens (80+ years).

"Normal" changes related to ageing are not usually regarded as disabilities, even though the impairments incurred by ageing may be indistinguishable from those of younger disabled people. The effects of ageing are described in CEN/CENELEC Guide 6 [i.13].

In the grouping shown, it may be assumed that the "younger" group is exhibiting the onset of ageing effects, probably without significant impairments. In the "middle age" the impairments progress and develop and become more significant. The "older" group can be assumed to be so impaired as to need regular assistance and protection.

B.4 Young People

Young people (children): This group may be even more diverse than other groups (the capabilities of a three-year old are clearly very different from an eight-year old or a twelve-year old, but also in this group there are very large individual variations). The 0 year to 2 year olds will not be considered here:

- *Pre-school* children (3 years to 5 years).
- *School age* children (6 years to 12 years).
- *Teen-agers* (13 years to 18 years).

Issues and guidelines related to young users of Information and Communication Technologies (ICT) equipment can be found in TR 102 133 [i.10]. A very young pre-school child or baby may not be aware that they are in an emergency situation, but it can reasonably be assumed that they normally have available assistance from a protective third party.

B.5 Terminal Issues

It is likely that it will not be possible to create technical solutions that will allow any person in the above categories to successfully make an emergency call from any terminal without assistance from a third party. The creation of such all-embracing solutions is, in some instances, likely to be logically impossible and not just technically challenging. For example, if a public telephone was designed to allow the shortest three-year old child to physically initiate an emergency call, a tall blind user would find such a low mounted terminal impossible to use to make an emergency call.

In practice, many of the people who would have the most difficulty with independently making emergency calls would have the constant support of another person who would be able to make an emergency call on their behalf. People with very severe cognitive impairments or very young children are likely to have a full-time care worker or a parent that could make emergency calls for them. Such realities will make it reasonable to assume that some combinations of user and terminal can be seen as outside the scope of the general requirements of clause 4.1. However, blanket exclusion of classes of user should never be accepted.

Whenever users have people to "permanently" assist them, they could at some time lose their assistant and need to make an emergency calls whilst alone. If a three-year child is alone with a parent and the parent dies the child should be able to make an emergency call. However, if the child's parent died whilst out of the house in a public place with a public payphone there is likelihood that there would be some other adult that could make an emergency call on the child's behalf. Therefore it might be considered reasonable that a three-year old child should be able to make an emergency call from their home telephone but unreasonable that all public terminals should be designed so that the same child could make an emergency call from such a terminal.

B.6 Network Issues

Many deaf people and people with a hearing or speech impairment operate independently in the workplace, at home and socially. If a person is deaf or has a hearing or speech impairment, then he/she may rely on the transmission and/or reception of text or video to access the telephone service. Being able to read and/or type using a textphone enables most individuals who cannot hear or speak to use the telephone independently. The transmission and reception of text, voice and/or video via the telephone network needs to be considered. If the voice channel is used for the transmission and reception of text, voice and/or video, then the requirements for the "push" or "pull" of location information (i.e. CLI for wireline networks and on the geographical co-ordinates for wireless networks) would be covered by the requirements outlined in the present document for voice calls via the voice channel. If the data or video channels are used for the transmission and reception of text, voice and/or video, then location information also needs to be carried in association with the data channel and video channel to the PSAP and the Emergency Response Organization.

Annex C: Bibliography

ETSI TS 101 109: "Digital cellular telecommunications system (Phase 2+); Universal Geographical Area Description (GAD) (3GPP TS 03.32)".

ETSI SR 002 299: "Emergency Communications; Collection of European Regulatory principles".

History

Document history		
V1.1.1	December 2003	Publication as SR 002 180
V1.1.1	February 2007	Publication
V1.2.1	July 2010	Publication