

## **Access and Terminals (AT); Study on out of band spectrum requirements for analogue PSTN terminals**

---



---

Reference

RTR/AT-010133

---

Keywords

access, outband, PSTN

**ETSI**

650 Route des Lucioles  
F-06921 Sophia Antipolis Cedex - FRANCE

Tel.: +33 4 92 94 42 00 Fax: +33 4 93 65 47 16

Siret N° 348 623 562 00017 - NAF 742 C  
Association à but non lucratif enregistrée à la  
Sous-Préfecture de Grasse (06) N° 7803/88

---

**Important notice**

Individual copies of the present document can be downloaded from:

<http://www.etsi.org>

The present document may be made available in more than one electronic version or in print. In any case of existing or perceived difference in contents between such versions, the reference version is the Portable Document Format (PDF). In case of dispute, the reference shall be the printing on ETSI printers of the PDF version kept on a specific network drive within ETSI Secretariat.

Users of the present document should be aware that the document may be subject to revision or change of status. Information on the current status of this and other ETSI documents is available at

<http://portal.etsi.org/tb/status/status.asp>

If you find errors in the present document, please send your comment to one of the following services:

[http://portal.etsi.org/chaicor/ETSI\\_support.asp](http://portal.etsi.org/chaicor/ETSI_support.asp)

---

**Copyright Notification**

No part may be reproduced except as authorized by written permission.  
The copyright and the foregoing restriction extend to reproduction in all media.

© European Telecommunications Standards Institute 2006.  
All rights reserved.

**DECT**<sup>TM</sup>, **PLUGTESTS**<sup>TM</sup> and **UMTS**<sup>TM</sup> are Trade Marks of ETSI registered for the benefit of its Members.  
**TIPHON**<sup>TM</sup> and the **TIPHON logo** are Trade Marks currently being registered by ETSI for the benefit of its Members.  
**3GPP**<sup>TM</sup> is a Trade Mark of ETSI registered for the benefit of its Members and of the 3GPP Organizational Partners.

# Contents

Intellectual Property Rights .....	4
Foreword.....	4
Introduction .....	4
1 Scope .....	5
2 References .....	5
3 Definitions and abbreviations.....	6
3.1 Definitions .....	6
3.2 Abbreviations .....	6
4 Various standards requirements .....	7
4.1 TBR 021 .....	7
4.2 TR 103 000-2-1 .....	7
4.3 FCC Part68 / EIA/TIA/IS-968.....	8
4.4 AS/ACIF S002:2001 (incl. Amendment No.1) .....	9
4.5 CNC-ST2-44-01 .....	10
4.6 NET 001/92 .....	10
4.7 HKTA 2011 Issue2.....	11
4.8 NO. S/INT-02W/01 .....	12
4.9 STEL D-001-1996.....	12
4.10 JATE 04/2001 .....	12
4.11 Art20 1998.....	13
4.12 PTC200-1997 .....	14
4.13 GOST 26557-85 .....	14
4.14 IDA TS PSTN1 issue4 2000.....	15
4.15 TE-001.....	16
4.16 PSTN 01 .....	16
4.17 Estimated POTS model from TR 101 830-1 .....	17
5 Comparison attempt between 10 kHz and 10 MHz.....	18
6 Proposal for an out-band spectrum requirement between 200 kHz and 30 MHz intended for spectral compatibility with xDSL.....	21
7 Conclusion.....	22
<b>Annex A: Reference Impedances .....</b>	<b>23</b>
A.1 Reference Impedance $Z_R$ .....	23
A.2 Reference Impedance $Z_{Rhf}$ .....	23
History .....	24

---

## Intellectual Property Rights

IPRs essential or potentially essential to the present document may have been declared to ETSI. The information pertaining to these essential IPRs, if any, is publicly available for **ETSI members and non-members**, and can be found in ETSI SR 000 314: "*Intellectual Property Rights (IPRs); Essential, or potentially Essential, IPRs notified to ETSI in respect of ETSI standards*", which is available from the ETSI Secretariat. Latest updates are available on the ETSI Web server (<http://webapp.etsi.org/IPR/home.asp>).

Pursuant to the ETSI IPR Policy, no investigation, including IPR searches, has been carried out by ETSI. No guarantee can be given as to the existence of other IPRs not referenced in ETSI SR 000 314 (or the updates on the ETSI Web server) which are, or may be, or may become, essential to the present document.

---

## Foreword

This Technical Report (TR) has been produced by ETSI Technical Committee Access and Terminals (AT).

---

## Introduction

The present document takes advantage of progress in other areas like:

- ongoing studies on frequency management on local loop;
- ongoing studies on measurement method;
- uploaded information from referenced and other authorities.

It facilitates a comparison among the requirements identified. For this purpose parameters like measurement bandwidth, were identified more precisely.

The present version of the document was enhanced with an extended scope.

The present document aims to facilitate further developments in standardization for the deployment of xDSL systems.

---

# 1 Scope

The present document describes and enumerates various requirements on metallic (horizontal) out of band spectrum for analogue terminals connected to the PSTN. An attempt to create an envelop of the various requirements is made and a limit for an out of band spectrum requirement protecting xDSL service is proposed to facilitate the standard convergence in this sector.

---

# 2 References

For the purposes of this Technical Report (TR), the following references apply:

- [1] ETSI TBR 021: "Terminal Equipment (TE); Attachment requirements for pan-European approval for connection to the analogue Public Switched Telephone Networks (PSTNs) of TE (excluding TE supporting the voice telephony service) in which network addressing, if provided, is by means of Dual Tone Multi Frequency (DTMF) signalling".
- [2] ETSI TR 103 000-2-1: " Access and Terminals (AT); Analogue Access to Public Telephone Network; Advisory Notes to Standards Harmonizing Terminal Interface; Part 2: Generally applicable Advisory Notes; Sub-part 1: Modification to sending spectral density requirements".
- [3] TIA/EIA/IS-968 (2001): "Telecommunications - Telephone Terminal Equipment - Technical Requirements for Connection of Terminal Equipment to the Telephone Network (2001)".  
<http://www.tiaonline.org/standards/>
- [4] AS/ACIF S002: "Analogue Interworking and Non interference Requirements for Customer Equipment Connected to the Public Switch Telephone Network".  
[http://www.acif.org.au/documents\\_and\\_lists/standards/S002\\_2005](http://www.acif.org.au/documents_and_lists/standards/S002_2005)
- [5] CNC-st2-44-01: "Reglamento Técnico Equipos Terminales Telefónicos (Argentina)".
- [6] NET 001/92: "Requisitos Mínimos Para Certificação de Equipamentos Terminais com Interfaceamento Analógico à Rede Telefônica Pública (Brasil)".
- [7] HKTA 2011 Issue2: "Network Connection Specification for Connection of Customer Premises Equipment (CPE) to Direct Exchange Lines (DEL) of the Public Switched Telephone Network (PSTN) in Hong-Kong".
- [8] NO. S/INT-02W/01: "Requirements of Subscribers End Equipment (SEE) Connected to 2-Wire Cable Plant (India) (Department of Telecommunications, Telecommunications Engineering Centre".
- [9] STEL D-001-1996: "Telecommunication Specification Modem Data Equipment (Indonesia)".
- [10] JATE: "Japan Approvals Institute for Telecommunications Equipment".
- [11] Art20: "Technical Criteria of Terminal Equipment (Korea) (Ministry of Information and Communication Proclamation N° 1998-18 of February 21 1998 and N° 1968-62 of March 9 1998)".
- [12] PTC200-1997: "Requirements for Connection of Customer Equipment to Analogue Lines (New-Zealand)".
- [13] GOST 26557-85: "Data transmission signals entering in the communication channels. Energetic parameters (Russia)".
- [14] IDA TS PSTN1 issue4: "Type Approval Specification for Terminal Equipment for Connection to the Public Switched Telephone Network (Singapore)".
- [15] TE-001: "Standard Specification For Telecommunication-Line Terminal Equipment for Connection to the Public Switched Telephone Network (South Africa)".

- [16] PSTN 01: "Technical Specification for Terminal Equipment for Connection to Public Switched Telephone Network (Taiwan)".
- [17] ETSI TR 101 830-1: "Transmission and Multiplexing (TM); Access networks; Spectral management on metallic access networks; Part 1: Definitions and signal library".
- [18] ES 203 021 (all parts): "Access and Terminals (AT); Harmonized basic attachment requirements for Terminals for connection to analogue interfaces of the Telephone Networks; Update of the technical contents of TBR 021, EN 301 437, TBR 015, TBR 017".
- [19] TR 101 830: "Transmission and Multiplexing (TM); Spectral management on metallic access networks".

## 3 Definitions and abbreviations

### 3.1 Definitions

For the purposes of the present document, the following terms and definitions apply:

**dBm:** Power (dBm) =  $10 \log (\text{Power1} / 1 \text{ mW}_{\text{rms}})$  where Power1 is measured in  $\text{mW}_{\text{rms}}$

**dBV:** Voltage (dBV) =  $20 \log (\text{Voltage1} / 1 \text{ V}_{\text{rms}})$  where Voltage1 is measured in  $\text{V}_{\text{rms}}$

**out of band:** any unwanted emission above 4,3 kHz

NOTE 1: Below 4,3 kHz applies to analogue telephony interfaces only.

NOTE 2: Some signals e.g.  $12 \text{ kHz} \pm 0,2 \text{ kHz}$  and  $16 \text{ kHz} \pm 0,2 \text{ kHz}$  signal frequencies are wanted and therefore allowed.

**Public Switched Telephone Network (PSTN):** used to describe the ordinary telephone system including subscriber lines, local exchanges and the complete system of trunks and the exchange hierarchy which makes up the network

**reference impedance 120  $\Omega$ :** pure resistor of 120  $\Omega$

**reference impedance 135  $\Omega$ :** pure resistor of 135  $\Omega$

**reference impedance 300  $\Omega$ :** pure resistor of 300  $\Omega$

**reference impedance 600  $\Omega$ :** pure resistor of 600  $\Omega$

**reference impedance  $Z_{\text{R}}$ :** complex impedance made up of 270  $\Omega$  in series with a parallel combination of 750  $\Omega$  and 150 nF

**reference impedance  $Z_{\text{Rhf}}$ :** complex impedance made up of 120  $\Omega$  in series with a parallel combination of 150  $\Omega$  and 47 nF in series with a parallel combination of 750  $\Omega$  and 150 nF

### 3.2 Abbreviations

For the purposes of the present document, the following abbreviations apply:

PSTN	Public Switched Telephone Network
Rbw	Resolution bandwidth
TE	Terminal Equipment

## 4 Various standards requirements

The disclosed information is simplified for comparison purpose. For more detail please refer to original document.

### 4.1 TBR 021

**Requirement:** As described in TBR 021 [1], clause 4.7.3.4 the total voltage level in a bandwidth, defined in table 4.1, wholly contained within the frequency range 4,3 kHz to 200 kHz, arising from normal operation of the TE when in an on-line, non-dialling state, and when terminated with  $Z_R$ , shall not exceed the limits shown in table 4.1 and figure 4.1.

**Table 4.1: Maximum sending level above 4,3 kHz**

Points	Frequency range (kHz)	Maximum sending level U in a specified bandwidth (dBV)	Spectral Voltage U/ $\sqrt{B}$ (dBV/ $\sqrt{\text{Hz}}$ )	Measurement bandwidth (B)	Reference impedance
G to H	4,3 to 5,1	-40 decreasing to -44	-64,8 decreasing to -68,8	300 Hz	$Z_R$
H to I	5,1 to 8,9	-44	-68,8	300 Hz	$Z_R$
I to J	8,9 to 11	-44 decreasing to -58,5	-68,8 decreasing to -83,3	300 Hz	$Z_R$
J to K	11 to 200	-58,5	-88,5	1 kHz	$Z_R$

NOTE: Limits for intermediate frequencies can be found by drawing a straight line between the break points on a logarithmic (Hz) - linear (dB) scale.

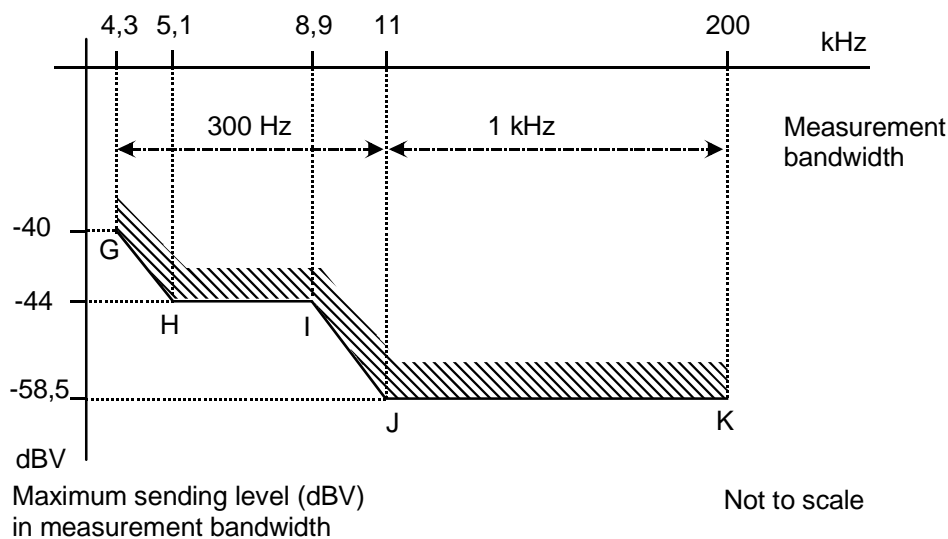

**Figure 4.1: Maximum sending level above 4,3 kHz**

### 4.2 TR 103 000-2-1

**Requirement:** As described in TR 103 002-2-1 [2], clause 4.3.2 the total voltage level in a bandwidth, defined in table 4.2, wholly contained within the frequency range 4,3 kHz to 200 kHz, arising from normal operation of the TE when in an on-line, non-dialling state, and when terminated with  $Z_R$ , shall not exceed the limits shown in table 4.2 and figure 4.2.

Table 4.2: Maximum sending level above 4,3 kHz

Points	Frequency range (kHz)	Maximum sending level U in a specified bandwidth (dBV)	Spectral Voltage $U/\sqrt{B}$ (dBV/ $\sqrt{\text{Hz}}$ )	Measurement bandwidth (B)	Reference impedance
G to H	4,3 to 6,0	-15	-39,8	300 Hz	$Z_R$
H to I	6,0 to 8,9	-15 decreasing to -44	-39,8 decreasing to -68,8	300 Hz	$Z_R$
I to J	8,9 to 12	-44 decreasing to -58,5	-68,8 decreasing to -83,3	300 Hz	$Z_R$
J to K	12 to 200	-58,5	-88,5	1 kHz	$Z_R$

NOTE: Limits for intermediate frequencies can be found by drawing a straight line between the break points on a logarithmic (Hz) - linear (dB) scale.

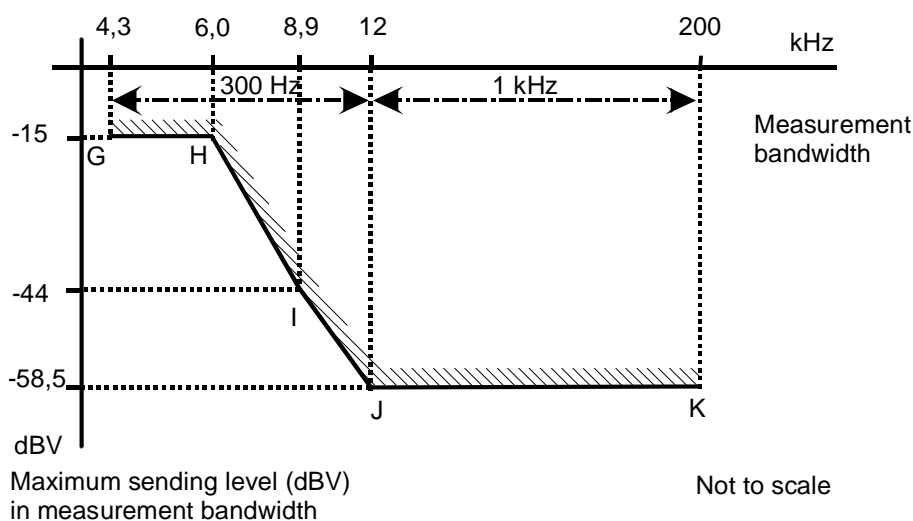

Figure 4.2: Maximum sending level above 4,3 kHz

## 4.3 FCC Part68 / EIA/TIA/IS-968

**Requirement:** As described in [3] 68.308c the total voltage level in a bandwidth shall not exceed the limits shown in table 4.3 and figure 4.3.

Table 4.3: Maximum sending level above 4 kHz

Points	Frequency range (kHz)	Maximum sending level U in a specified bandwidth (dBV)	Spectral Voltage $U/\sqrt{B}$ (dBV/ $\sqrt{\text{Hz}}$ )	Measurement bandwidth (B)	Reference impedance
A to B	4 to 12	-14 decreasing to -20	-50 decreasing to -56	4 kHz	300 $\Omega$
C to D	12 to 90	-20,2 decreasing to -55,2	-56,2 decreasing to -91,2	4 kHz	135 $\Omega$
D to E	90 to 266	-55	-91	4 kHz	135 $\Omega$
F to G	270 to 6 000	-15	-51	4 kHz	135 $\Omega$

NOTE: Limits for intermediate frequencies can be found by drawing a straight line between the break points on a logarithmic (Hz) - linear (dB) scale. Reference impedances are pure resistors.



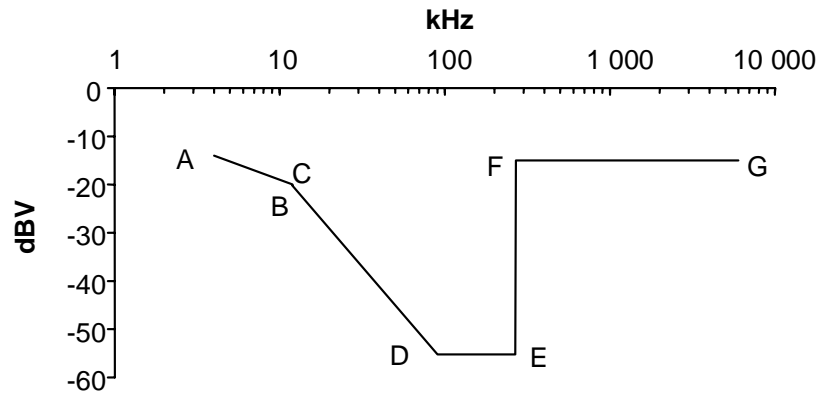

Figure 4.3: Maximum sending level above 4 kHz

#### 4.4 AS/ACIF S002:2001 (incl. Amendment No.1)

**Requirement:** As described in [4], clause 5.4.2 the total voltage level in a bandwidth shall not exceed the limits shown in table 4.4.1 and figure 4.4.1 and in table 4.4.2 and figure 4.4.2.

Table 4.4.1: Maximum sending level above 3,4 kHz in 10 kHz bandwidth

Points	Frequency range (kHz)	Maximum signal level P (dBm)	Spectral Power P/B (dBm/Hz)	Measurement bandwidth (B)	Reference impedance
A to B	3,4 to 100	-5	-45	10 kHz	135 $\Omega$
B to C	100 to 500	-5 decreasing to -40	-45 decreasing to -80	10 kHz	135 $\Omega$
C to D	500 to 1 400	-40	-80	10 kHz	135 $\Omega$
D to E	1 400 to 5 000	-40 decreasing to -80	-80 decreasing to -120	10 kHz	135 $\Omega$
E to F	5 000 to 12 040	-80	-120	10 kHz	135 $\Omega$

NOTE: Limits for intermediate frequencies can be found by drawing a straight line between the break points on a logarithmic (Hz) - linear (dB) scale. Reference impedance is pure resistor.

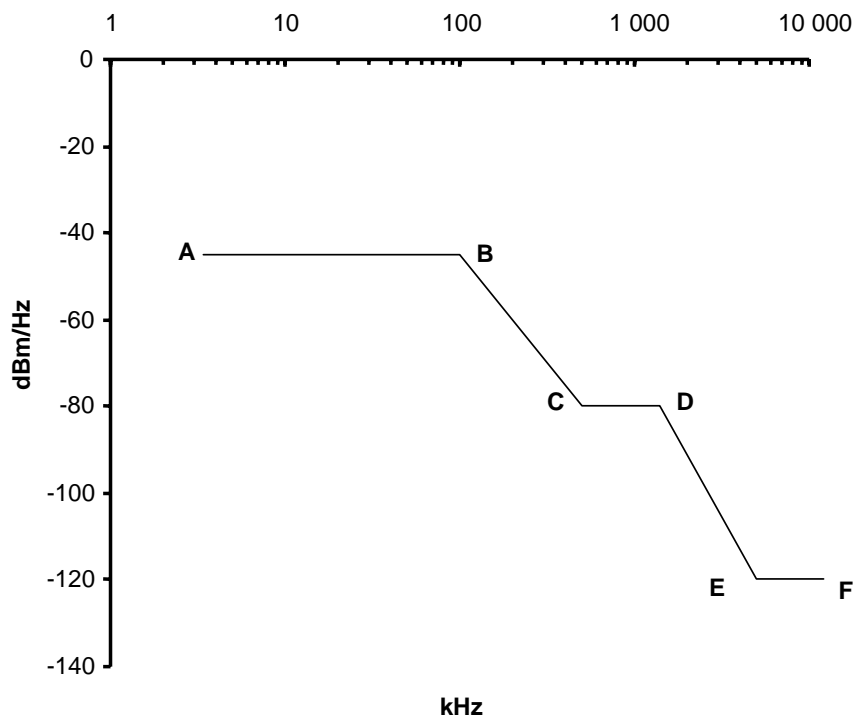
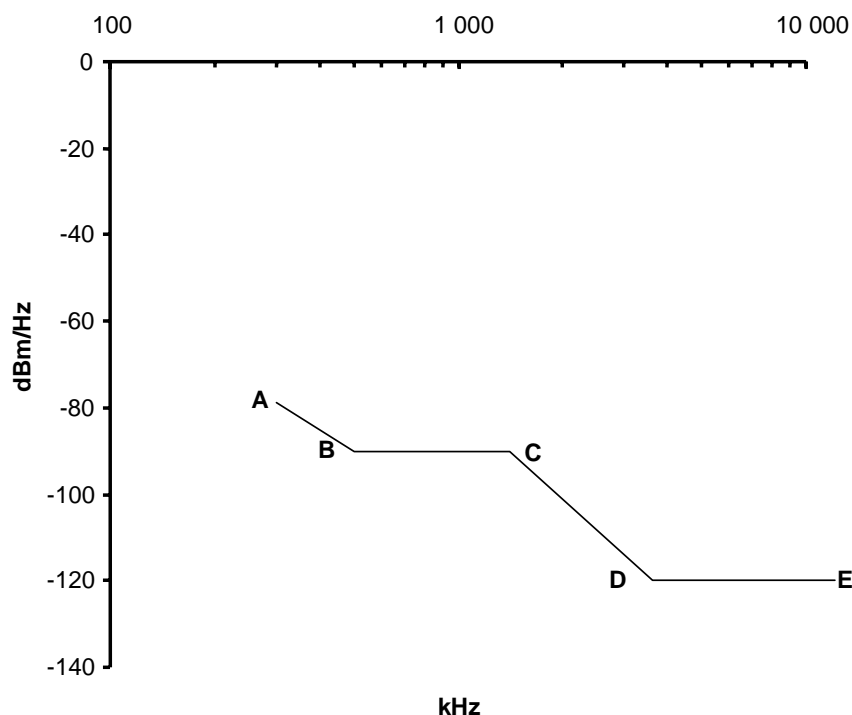

Figure 4.4.1: Maximum sending level above 3,4 kHz in 10 kHz bandwidth

**Table 4.4.2: Maximum sending level above 3,4 kHz in 1 MHz bandwidth**

Points	Frequency range (kHz)	Maximum signal level P (dBm)	Spectral Power P/B (dBm/Hz)	Measurement bandwidth (B)	Reference impedance
A to B	300 to 500	-18,9 decreasing to -30	-78,9 decreasing to -90	1 MHz	135 $\Omega$
B to C	500 to 1 400	-30	-90	1 MHz	135 $\Omega$
C to D	1 400 to 3 422	-30 decreasing to -60	-90 decreasing to -120	1 MHz	135 $\Omega$
D to E	3 422 to 12 040	-60	-120	1 MHz	135 $\Omega$

NOTE: Limits for intermediate frequencies can be found by drawing a straight line between the break points on a logarithmic (Hz) - linear (dB) scale. Reference impedance is pure resistor. In AS/ACIF S002+A1 the reference frequency is the lower edge of a 1 MHz sliding window.

**Figure 4.4.2: Maximum sending level above 3,4 kHz**

## 4.5 CNC-ST2-44-01

**Requirement:** As described in CNC-st2-44-01 [5], clause 4.2.3 the total voltage level in a bandwidth shall decrease as -6 dB per Octave.

## 4.6 NET 001/92

**Requirement:** As described in NET 001/92 [6], clause 5.6.3 the total voltage level in a bandwidth shall not exceed the limits shown in table 4.6 and figure 4.6.

**Table 4.6: Maximum sending level above 4 kHz**

Points	Frequency range (kHz)	Maximum sending level in an unspecified bandwidth (dBm)	Measurement bandwidth	Reference impedance
A to B	4 to 8	-30	Not specified	600 $\Omega$
C to D	8 to 12	-50	Not specified	600 $\Omega$
E to F	12 to 1 000	-70	Not specified	600 $\Omega$

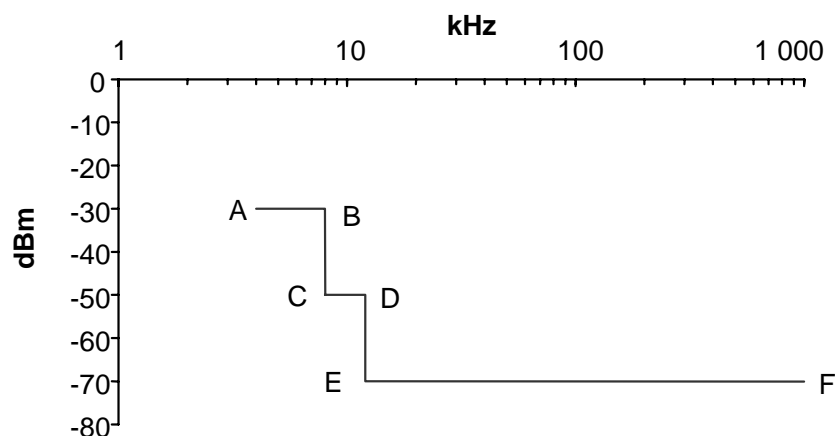

Figure 4.6: Maximum sending level above 4 kHz

## 4.7 HKTA 2011 Issue2

**Requirement:** As described in [7], clause 3.4 the total voltage level in a bandwidth shall not exceed the limits shown in table 4.7 and figure 4.7.

Table 4.7: Maximum sending level above 4 kHz

Points	Center frequency in (kHz)	Maximum sending level U in a specified bandwidth (dBV)	Spectral Voltage U/ $\sqrt{B}$ (dBV/ $\sqrt{\text{Hz}}$ )	Measurement bandwidth (B)	Reference impedance
A to B	8 to 12	-17,8 decreasing to -20	-56,8 decreasing to -59	8 kHz	300 $\Omega$
B to C	12 to 90	-20 decreasing to -55,1	-59 decreasing to -94,1	8 kHz	135 $\Omega$
D to E	90 to 266	-55	-94	8 kHz	135 $\Omega$

NOTE: Limits for intermediate frequencies can be found by drawing a straight line between the break points on a logarithmic (Hz) - linear (dB) scale. Reference impedances are pure resistors.

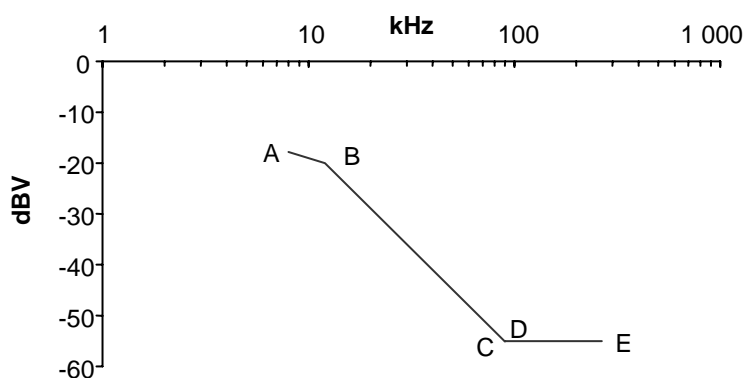

Figure 4.7: Maximum sending level above 4 kHz

## 4.8 NO. S/INT-02W/01

**Requirement:** As described in [8], clause 2.1.3.4.3.7.3 the total voltage level in a bandwidth shall not exceed the limits shown in table 4.8 and figure 4.8.

**Table 4.8: Maximum sending level above 3,4 kHz**

Points	Frequency range (kHz)	Maximum sending level in an unspecified bandwidth (dBm)	Measurement bandwidth	Reference Impedance
A to B	3,4 to 5,1	-33 decreasing to -40	Not specified	600 $\Omega$
B to C	5,1 to 8,9	-40	Not specified	600 $\Omega$
C to D	8,9 to 50	-40 decreasing to -70	Not specified	600 $\Omega$
D to E	50 to 10 000	-70	Not specified	600 $\Omega$

NOTE: Limits for intermediate frequencies can be found by drawing a straight line between the break points on a logarithmic (Hz) - linear (dB) scale. Reference impedance is pure resistor.

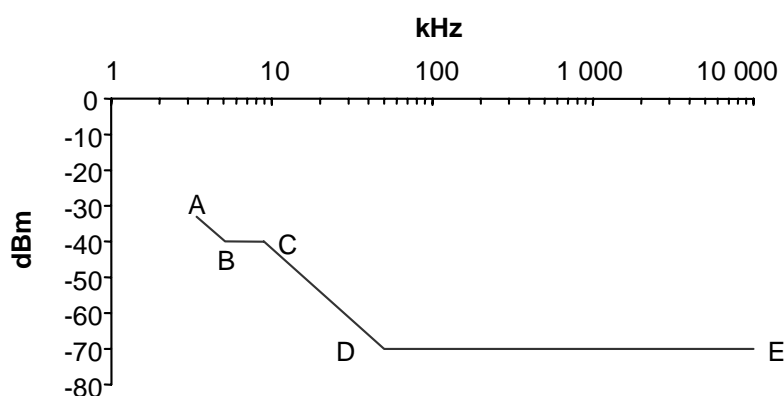

**Figure 4.8: Maximum sending level above 3,4 kHz**

## 4.9 STEL D-001-1996

**Requirement:** Not specified in [9].

## 4.10 JATE 04/2001

**Requirement:** As described in [10] article 14 the total voltage level in a bandwidth shall not exceed the limits shown in table 4.10 and figure 4.10.

**Table 4.10: Maximum sending level above 4 kHz**

Points	Frequency range (kHz)	Maximum signal level P (dBm)	Spectral Power P/B (dBm/Hz)	Measurement bandwidth (B)	Reference impedance
A to B	4 to 8	-20	-56	4 kHz	600 $\Omega$
C to D	8 to 12	-40	-76	4 kHz	600 $\Omega$
E to F	12 and more	-60	-96	4 kHz	600 $\Omega$

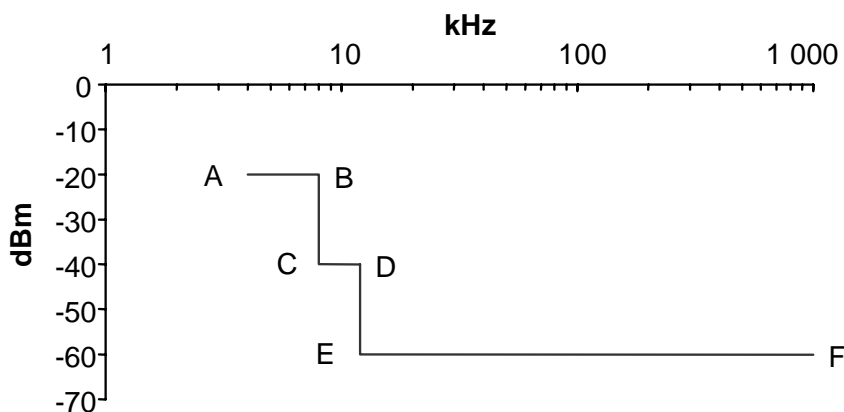

Figure 4.10: Maximum sending level above 4 kHz

## 4.11 Art20 1998

**Requirement:** As described in [11], clause 3 the total voltage level in a bandwidth shall not exceed the limits shown in table 4.11 and figure 4.11.

Table 4.11: Maximum sending level above 4 kHz

Points	Center Frequency (kHz)	Maximum sending level U in a specified bandwidth (dBV)	Spectral Voltage U/ $\sqrt{B}$ (dBV/ $\sqrt{Hz}$ )	Measurement bandwidth (B)	Reference impedance
A to B	8 to 12	-17,8 decreasing to -20	-56,8 decreasing to -59	8 kHz	300 $\Omega$
B to C	12 to 90	-20 decreasing to -55,1	-59 decreasing to -94,1	8 kHz	135 $\Omega$
D to E	90 to 266	-55	-94	8 kHz	135 $\Omega$

NOTE: Limits for intermediate frequencies can be found by drawing a straight line between the break points on a logarithmic (Hz) - linear (dB) scale. Reference impedances are pure resistors.

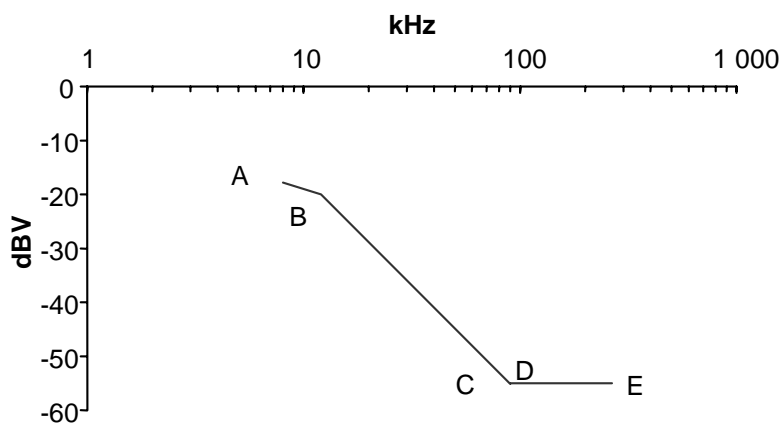

Figure 4.11: Maximum sending level above 4 kHz

## 4.12 PTC200-1997

**Requirement:** As described in [12], clause 4.3 the total voltage level in a bandwidth shall not exceed the limits shown in table 4.12 and figure 4.12.

**Table 4.12: Maximum sending level above 4 kHz**

Points	Frequency range (kHz)	Maximum signal level P (dBm)	Spectral Power P/B (dBm/Hz)	Measurement bandwidth (B)	Reference impedance
A to B	4 to 10	-40	-74,8	3 kHz	600 $\Omega$
B to C	10 to 20	-40 decreasing to -50	-74,8 decreasing to -84,8	3 kHz	600 $\Omega$
C to D	20 to 50	-50 decreasing to -70	-84,8 decreasing to -104,8	3 kHz	600 $\Omega$
D to E	50 to 100	-70	-104,8	3 kHz	600 $\Omega$
F to G	100 to 10 000	-50	-84,8	3 kHz	600 $\Omega$

NOTE: Limits for intermediate frequencies can be found by drawing a straight line between the break points on a logarithmic (Hz) - linear (dB) scale. Reference impedance is pure resistor.

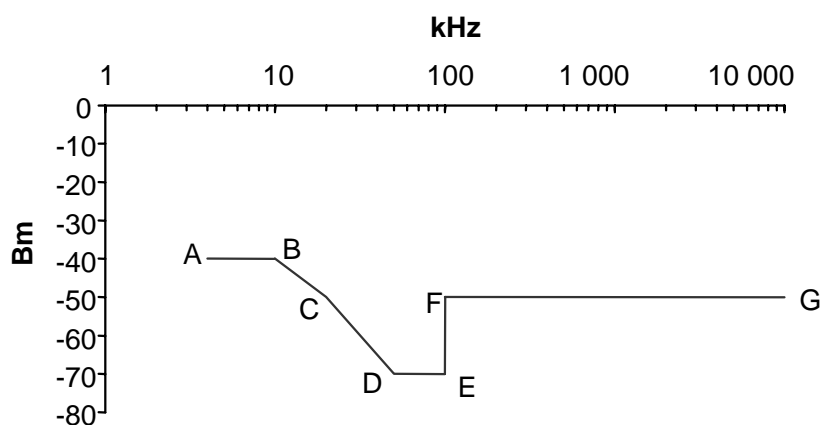

**Figure 4.12: Maximum sending level above 4 kHz**

## 4.13 GOST 26557-85

**Requirement:** As described in [13], clause 6.4.1.3 the total voltage level in a bandwidth shall not exceed the limits shown in table 4.13 and figure 4.13.

**Table 4.13: Maximum sending level above 3,4 kHz**

Points	Frequency range (kHz)	Maximum sending level in an unspecified bandwidth (dBm)	Measurement bandwidth	Reference impedance
A to B	3,4 to 10	-30 decreasing to -60	Not specified	600 $\Omega$
B to C	10 to 100	-60	Not specified	600 $\Omega$

NOTE: Limits for intermediate frequencies can be found by drawing a straight line between the break points on a logarithmic (Hz) - linear (dB) scale. Reference impedance is pure resistor.

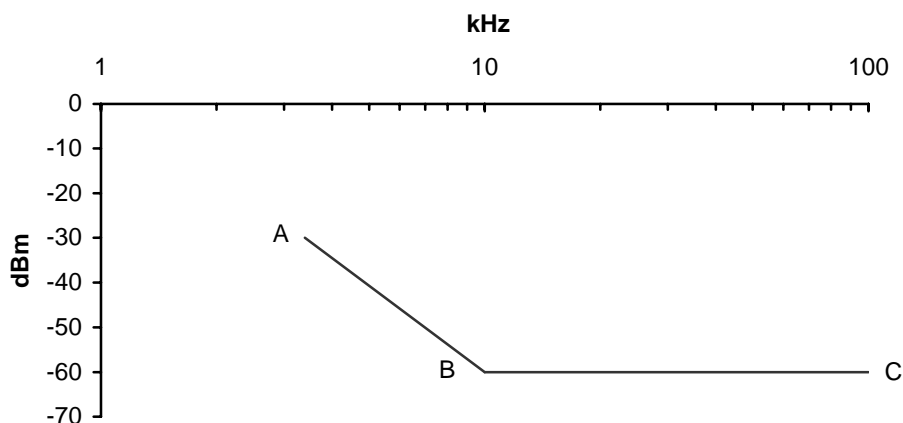

Figure 4.13: Maximum sending level above 3,4 kHz

## 4.14 IDA TS PSTN1 issue4 2000

**Requirement:** As described in [14], clause 6.4.1.3 the total voltage level in a bandwidth shall not exceed the limits shown in table 4.14 and figure 4.14.

Table 4.14: Maximum sending level above 3,4 kHz

Points	Frequency range (kHz)	Maximum sending level in an unspecified bandwidth (dBm)	Measurement bandwidth	Reference Impedance
A to B	3,4 to 50	-33	Not specified	600 $\Omega$
C to D	50 to 200	-70	Not specified	600 $\Omega$

NOTE: Reference impedance is pure resistor.

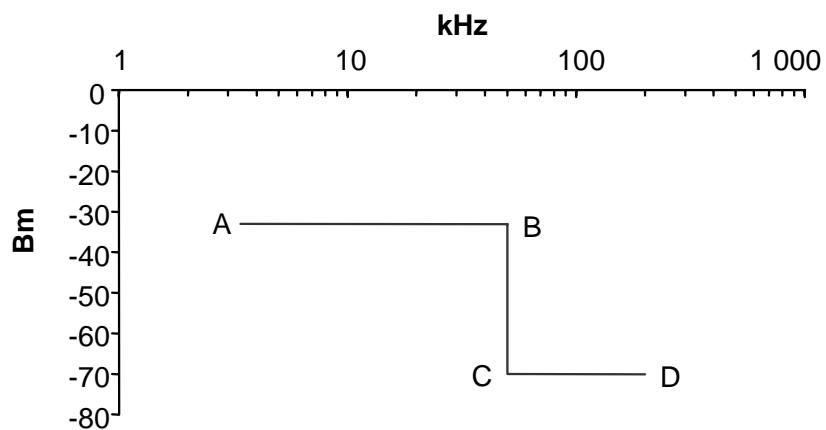

Figure 4.14: Maximum sending level above 3,4 kHz

## 4.15 TE-001

**Requirement:** As described in [15], clause 14.4 the total voltage level in a bandwidth shall not exceed the limits shown in table 4.15 and figure 4.15.

**Table 4.15: Maximum sending level above 3,4 kHz**

Points	Frequency range (kHz)	Maximum signal level P (dBm)	Spectral Power P/B (dBm/Hz)	Measurement bandwidth (B)	Reference impedance
A to B	3,4 to 5	-35	-65	1 kHz	$Z_1$
B to C	5 to 9	-40	-70	1 kHz	$Z_1$
C to D	9 to 50	-40 decreasing to -70	-70 decreasing to -100	1 kHz	$Z_1$
D to E	50 to 1 000	-70	-100	1 kHz	$Z_1$

NOTE: Limits for intermediate frequencies can be found by drawing a straight line between the break points on a logarithmic (Hz) - linear (dB) scale.

Z1: 220  $\Omega$  in serie with a combination of 820  $\Omega$  in parallel with 115 nF, is being replaced by  $Z_{Rhf}$ .

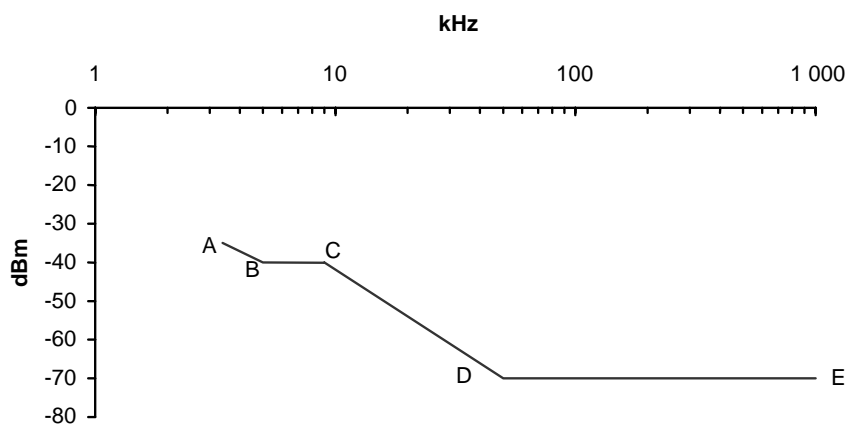

**Figure 4.15: Maximum sending level above 3,4 kHz**

## 4.16 PSTN 01

**Requirement:** As described in [16], clause 5.1.8 the total voltage level in a bandwidth shall not exceed the limits shown in table 4.16 and figure 4.16.

**Table 4.16: Maximum sending level above 4 kHz**

Points	Frequency range (kHz)	Maximum signal level P (dBm)	Spectral Power P/B (dBm/Hz)	Measurement bandwidth (B)	Reference impedance
A to B	4 to 8	-20	-56	4 kHz	600 $\Omega$
C to D	8 to 12	-40	-76	4 kHz	600 $\Omega$
E to F	12 to 48	-60	-96	4 kHz	600 $\Omega$



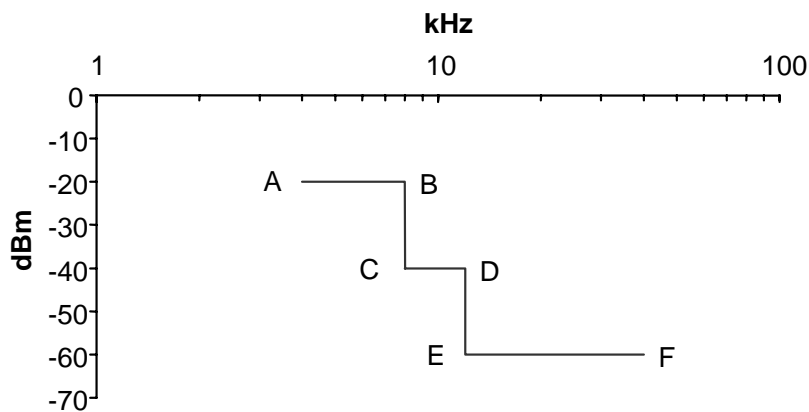

Figure 4.16: Maximum sending level above 4 kHz

## 4.17 Estimated POTS model from TR 101 830-1

**Description:** As described in [17], clause 8.1.3 the total voltage level in a bandwidth is estimated not to exceed the limits shown in table 4.17 and figure 4.17.

Table 4.17: Break points of the narrow-band voltage limits

Frequency (F)	Impedance (Z)	Signal Level (U)	Power Bandwidth (B)	Spectral Voltage (U/ $\sqrt{B}$ )
30 Hz	$Z_R$	-33,7 dBV	10 Hz	-43,7 dBV/ $\sqrt{\text{Hz}}$
100 Hz	$Z_R$	-10,7 dBV	10 Hz	-20,7 dBV/ $\sqrt{\text{Hz}}$
200 Hz	$Z_R$	-6,7 dBV	10 Hz	-16,7 dBV/ $\sqrt{\text{Hz}}$
3,8 kHz	$Z_R$	-6,7 dBV	10 Hz	-16,7 dBV/ $\sqrt{\text{Hz}}$
3,9 kHz	$Z_R$	-10,7 dBV	10 Hz	-20,7 dBV/ $\sqrt{\text{Hz}}$
4,0 kHz	$Z_R$	-16,7 dBV	10 Hz	-26,7 dBV/ $\sqrt{\text{Hz}}$
4,3 kHz	$Z_R$	-44,7 dBV	10 Hz	-54,7 dBV/ $\sqrt{\text{Hz}}$
4,3 kHz	$Z_R$	-40 dBV	300 Hz	-65 dBV/ $\sqrt{\text{Hz}}$
5,1 kHz	$Z_R$	-44 dBV	300 Hz	-69 dBV/ $\sqrt{\text{Hz}}$
8,9 kHz	$Z_R$	-44 dBV	300 Hz	-69 dBV/ $\sqrt{\text{Hz}}$
11,0 kHz	$Z_R$	-58,5 dBV	300 Hz	-83,5 dBV/ $\sqrt{\text{Hz}}$
11,0 kHz	$Z_R$	-58,5 dBV	1 kHz	-88,5 dBV/ $\sqrt{\text{Hz}}$
200 kHz	$Z_R$	-58,5 dBV	1 kHz	-88,5 dBV/ $\sqrt{\text{Hz}}$
200 kHz	135 $\Omega$	-60 dBV	1 kHz	-90 dBV/ $\sqrt{\text{Hz}}$
500 kHz	135 $\Omega$	-90 dBV	1 kHz	-120 dBV/ $\sqrt{\text{Hz}}$
500 kHz	135 $\Omega$	-60 dBV	1 MHz	-120 dBV/ $\sqrt{\text{Hz}}$
30 MHz	135 $\Omega$	-60 dBV	1 MHz	-120 dBV/ $\sqrt{\text{Hz}}$

NOTE: A voltage of 1 V, equals 0 dBV, and causes a power of +2,2 dBm in 600  $\Omega$  and +8,7 dBm in 135  $\Omega$ .

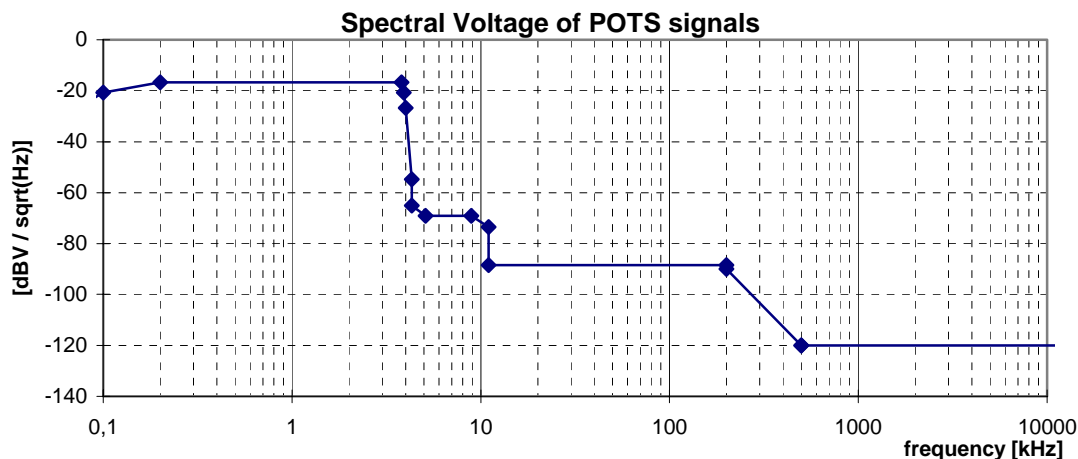

**Figure 4.17: Spectral Voltage for POTS signal**

## 5 Comparison attempt between 10 kHz and 10 MHz

Hypothesis:

- All limits are translated into a dBm/Hz scale.
- Whenever Rbw is not defined in the specification, it is supposed to be 1 kHz.

NOTE: Those values are derived from formal documents but might not correspond exactly to the national applicable requirement because in some case assumption were made to overcome insufficient information (e.g. rbw definition).

It is not possible to directly compare various out of band spectrum requirements using different reference impedances and various resolution bandwidth. Three big categories are present:

- 135  $\Omega$  reference and narrow resolution bandwidth (less than 10 kHz).
- 135  $\Omega$  reference impedance and large resolution bandwidth (1 MHz).
- 600  $\Omega$  reference impedance and narrow resolution bandwidth (less than 10 kHz).

Above 10 kHz complex impedance like  $Z_r$  are considered as being reduced to their real part. For  $Z_r$  it is 270  $\Omega$ .

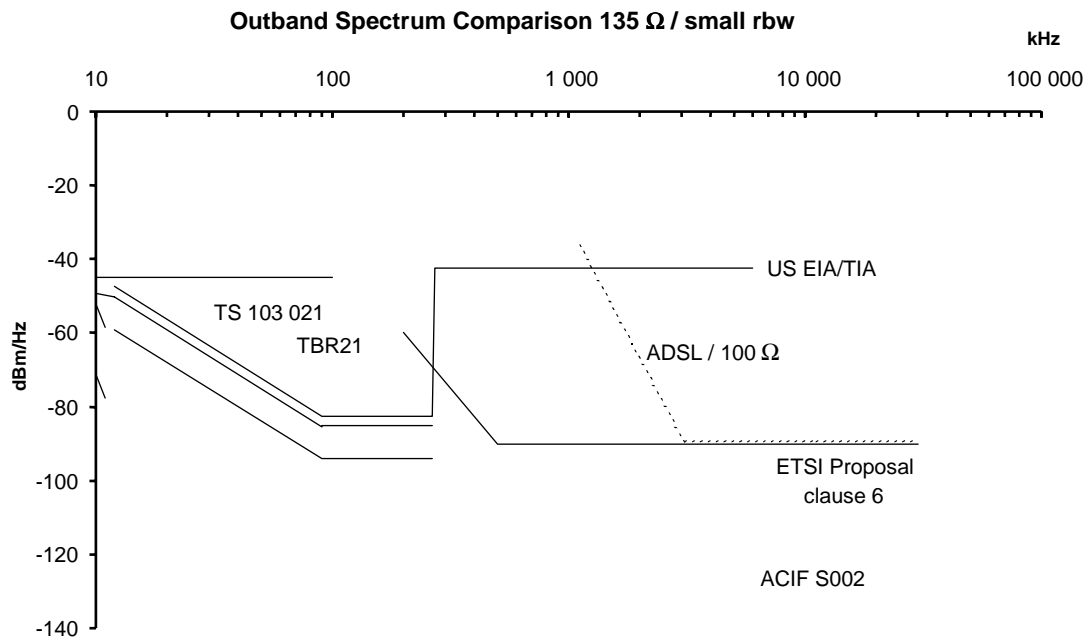

**Figure 5a**

It is also interesting to include ADSL even though it is using 100  $\Omega$  reference impedance.

It can be noted that the level of -90 dBm/Hz is consistent and comparable with the levels obtained over 600  $\Omega$  as you can see below figure 5b with -100 dBm/Hz. It can also be noted that the Australian new requirement is 20 dB to 30 dB more stringent than the other various requirements.

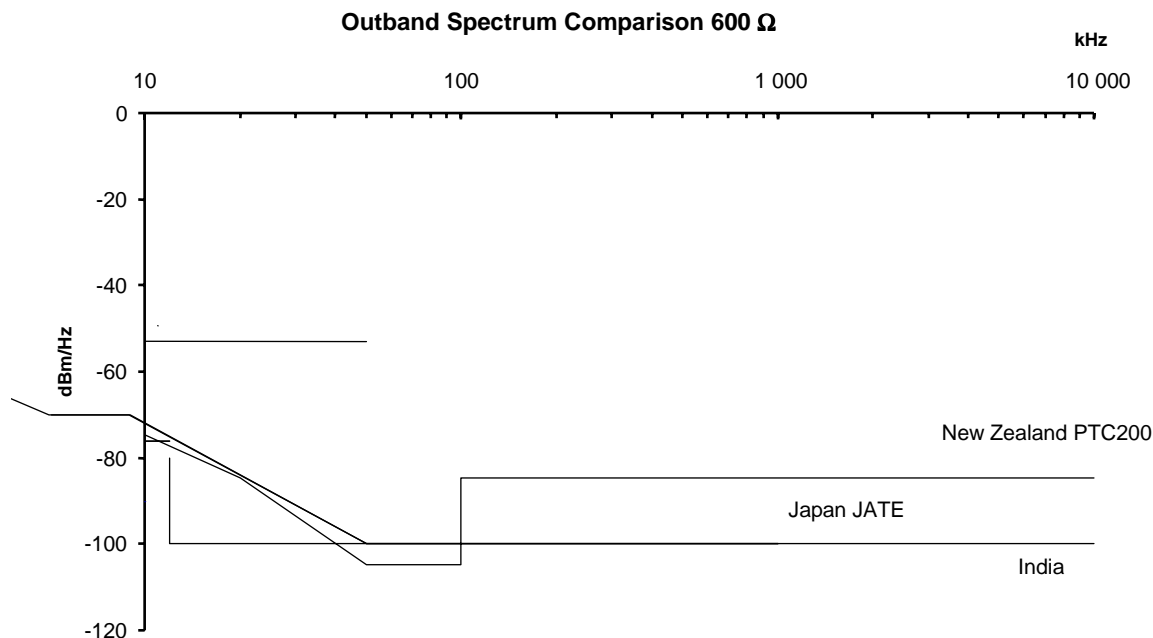

NOTE 1: Those values are derived from formal documents but might not correspond exactly to the national applicable requirement because in some case assumption were made to overcome insufficient information (e.g. rbw definition).

NOTE 2: Those values are derived from formal documents but might not correspond exactly to the national applicable requirement because in some case assumption were made to overcome insufficient information (e.g. rbw definition).

NOTE 3: Those values are derived from formal documents but might not correspond exactly to the national applicable requirement because in some case assumption were made to overcome insufficient information (e.g. rbw definition).

**Figure 5b**

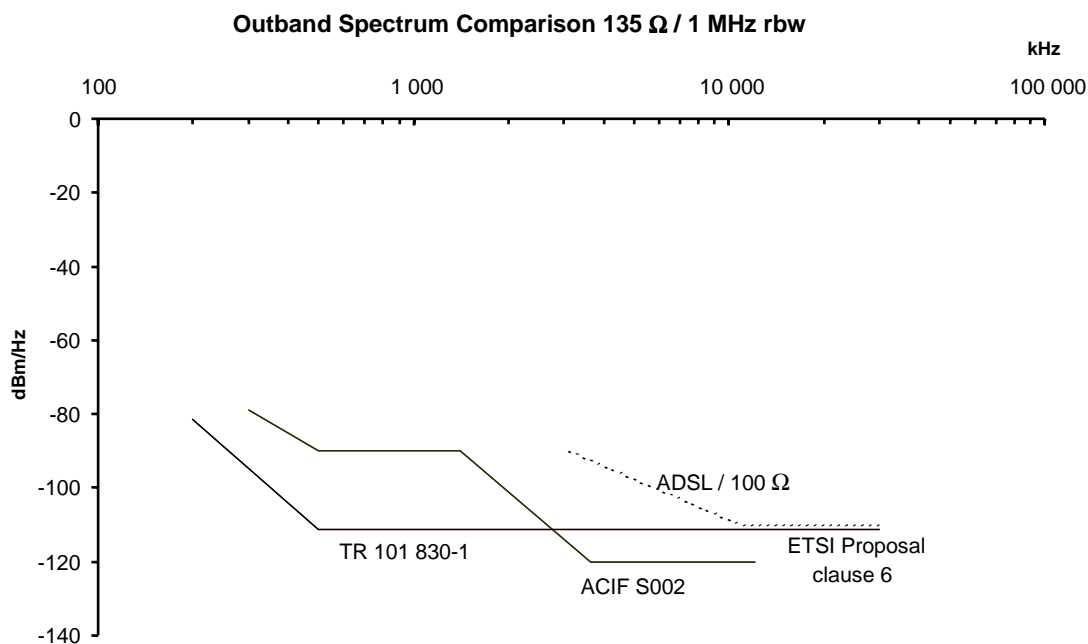

**Figure 5c**

On figure 5c the various requirements are all very consistent at -110 dBm/Hz and -120 dBm/Hz.

Conclusion: the suggested values of TR 101 830-1 [17] are suitable for a requirement extension proposal of out of band spectrum of ES 203 021 [18] for POTS.

## 6 Proposal for an out-band spectrum requirement between 200 kHz and 30 MHz intended for spectral compatibility with xDSL

This clause only proposes a level of the out of band signal of an analog PSTN TE that would minimize crosstalk interference and reduce signal level on the same pair. The impedance requirements for operation on the same pair are not considered in the present document.

The level proposed below considers the suggestion of TR 101 830 [19] which is also an envelop of the various national requirements below 12 MHz. A limit is introduced for individual frequencies (as in TBR 021 [1] and in ES 203 021 [18]) with an additional requirement using a 10 kHz measurement bandwidth.

It is suggested to measure various existing TE with this method prior to standardization work.

**Table 6: Maximum sending between 200 kHz and 30 MHz**

Points	Frequency range (MHz)	Maximum sending level U in a specified bandwidth (dBV)	Spectral Voltage U/ $\sqrt{B}$ (dBV/ $\sqrt{\text{Hz}}$ )	Measurement bandwidth (B)	Reference impedance
A to B	0,2 to 0,5	-60 dBV	-100 dBV/ $\sqrt{\text{Hz}}$	10 kHz	$Z_{\text{Rhf}}$
B to C	0,5 to 30	-60 dBV	-100 dBV/ $\sqrt{\text{Hz}}$	10 kHz	$Z_{\text{Rhf}}$
B to C	0,5 to 30	-60 dBV	-120 dBV/ $\sqrt{\text{Hz}}$	1 MHz	$Z_{\text{Rhf}}$

NOTE: A voltage of 1 V, equals 0 dBV, and causes a power of +2,2 dBm in 600 Ω, +8,7 dBm in 135 Ω and +9,2 dBm in 120 Ω.

---

## 7 Conclusion

The possibility of a common measurement method and a limit value for the frequency domain of the requirements is discussed and suggestions for future global standardization work specified.

The information in the present document should be of assistance for spectrum management studies, PSTN and xDSL devices (terminals and conventional line access equipment).

Due to the fact that many parameters e.g. test impedance, resolution bandwidth the proposal for harmonization should not be definitely taken. Before standardization work establishes harmonized values it is extremely important to confirm (e.g. by field tests) that the suggested values are appropriate.

---

## Annex A: Reference Impedances

### A.1 Reference Impedance $Z_R$

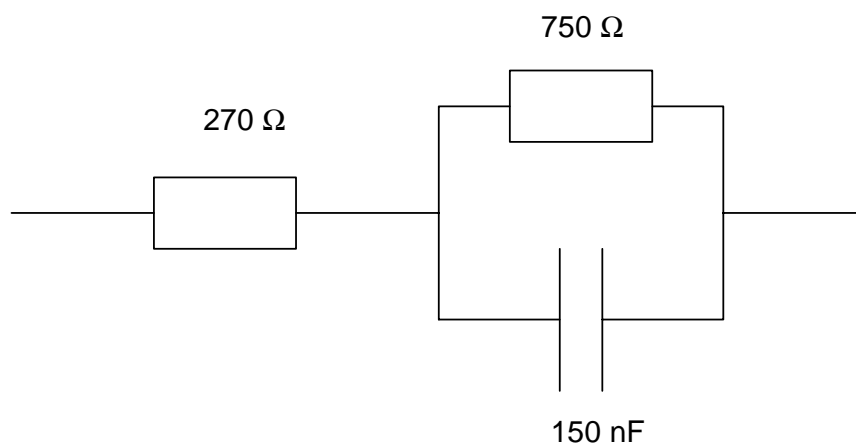
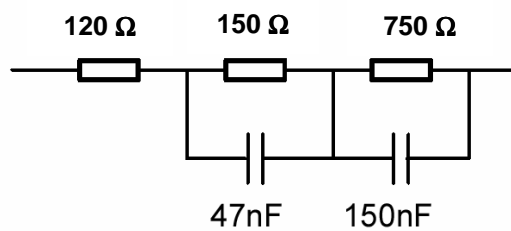

Figure A.1: Reference impedance  $Z_R$

---

### A.2 Reference Impedance $Z_{Rhf}$



Impedance  $Z_{RHF}$

Figure A.2

---

## History

<b>Document history</b>		
V1.1.1	May 2002	Publication
V1.2.1	January 2004	Publication
V1.2.2	January 2006	Publication