

**Electromagnetic compatibility
and Radio spectrum Matters (ERM);
Study on 27 MHz CB radio compatibility
with analogue television broadcast
receiver installations**



Reference

DTR/ERM-TG8-001

Keywords

CB, EMC, interoperability, radio, testing

ETSI

650 Route des Lucioles
F-06921 Sophia Antipolis Cedex - FRANCE

Tel.: +33 4 92 94 42 00 Fax: +33 4 93 65 47 16

Siret N° 348 623 562 00017 - NAF 742 C
Association à but non lucratif enregistrée à la
Sous-Préfecture de Grasse (06) N° 7803/88

Important noticeIndividual copies of the present document can be downloaded from:
<http://www.etsi.org>

The present document may be made available in more than one electronic version or in print. In any case of existing or perceived difference in contents between such versions, the reference version is the Portable Document Format (PDF). In case of dispute, the reference shall be the printing on ETSI printers of the PDF version kept on a specific network drive within ETSI Secretariat.

Users of the present document should be aware that the document may be subject to revision or change of status. Information on the current status of this and other ETSI documents is available at <http://www.etsi.org/tb/status/>

If you find errors in the present document, send your comment to:
editor@etsi.fr

Copyright Notification

No part may be reproduced except as authorized by written permission.
The copyright and the foregoing restriction extend to reproduction in all media.

© European Telecommunications Standards Institute 2000.
All rights reserved.

Contents

Intellectual Property Rights	5
Foreword.....	5
Introduction	5
1 Scope	6
2 References	6
3 Definitions, symbols and abbreviations	7
3.1 Definitions	7
3.2 Symbols.....	8
3.3 Abbreviations	8
4 Calibration of a CB antenna for reference use	8
4.1 CB antenna to calibration purpose for reference use.....	8
4.2 Antenna calibration method	9
4.3 Results	9
4.3.1 Gain of the CB antenna.....	9
4.3.2 Measurements check up.....	10
4.4 Comments.....	10
5 Test on different parts of TV-FM radio installations	10
5.1 Gain at 27 MHz of TV and FM radio reception antennas	10
5.1.1 TV and FM radio antennas for testing purposes	10
5.1.2 Measurements method and test conditions	10
5.1.3 Results	11
5.1.4 Comments	11
5.2 27 MHz RF level delivered by the TV antenna.....	12
5.2.1 TV antenna and equipment for testing purposes.....	12
5.2.2 Measurement method and test conditions	12
5.2.3 Results	12
5.2.4 Comments	13
5.3 Induced RF 27 MHz on the TV antenna cable	13
5.3.1 Non ground referenced load cable	14
5.3.1.1 Measurement method and test conditions	14
5.3.1.2 Results.....	14
5.3.2 Ground referenced load cable	15
5.3.2.1 Measurement method and test conditions	15
5.3.2.2 Results.....	15
5.3.3 Comments	15
5.4 Immunity of TV and FM radio antenna amplifiers to 27 MHz	16
5.4.1 Bandwidth and selectivity.....	16
5.4.1.1 Antenna amplifiers for testing purpose	16
5.4.1.2 Measurements method and test conditions.....	16
5.4.1.3 Results.....	17
5.4.1.4 Comments	19
5.4.2 External immunity to a surrounding 27 MHz EM fields	19
5.4.2.1 Antenna amplifier for testing purpose.....	19
5.4.2.2 Measurement method and test conditions	19
5.4.2.3 Results.....	20
5.4.2.4 Comments	20
5.4.3 External immunity to 27 MHz signal through the connection cable.....	21
5.4.3.1 Antenna amplifiers for testing purpose	21
5.4.3.2 Measurements method and test conditions.....	21
5.4.3.3 Results.....	22
5.4.3.4 Comments	22
5.4.3.5 Complementary measurements	22
5.4.3.6 Comments	23

5.5	TV sets immunity test with a 27 MHz signal by conduction.....	23
5.5.1	Laboratory test	23
5.5.1.1	Measurement method and test conditions	23
5.5.1.2	Results	24
5.5.1.3	Comments	24
5.5.2	Test in a real TV receiving site with a 27 MHz AM signal	25
5.5.2.1	Measurement method and test conditions	25
5.5.2.2	Results	26
5.5.2.3	Comments	26
6	Complete TV installation illuminated by a 27 MHz field.....	27
6.1	Test in free field measurements site	27
6.1.1	Materials for testing purpose	27
6.1.2	Measurement method and test conditions	27
6.1.3	Results	28
6.2	Test on real conditions in a residence site	28
6.2.1	Measurements method and test conditions	28
6.2.2	Results	29
6.3	Immunity synthesis of 20 complete TV installations	29
6.4	Comments.....	30
7	Conclusions	30
	History	32

Intellectual Property Rights

IPRs essential or potentially essential to the present document may have been declared to ETSI. The information pertaining to these essential IPRs, if any, is publicly available for **ETSI members and non-members**, and can be found in ETSI SR 000 314: "*Intellectual Property Rights (IPRs); Essential, or potentially Essential, IPRs notified to ETSI in respect of ETSI standards*", which is available from the ETSI Secretariat. Latest updates are available on the ETSI Web server (<http://www.etsi.org/ipr>).

Pursuant to the ETSI IPR Policy, no investigation, including IPR searches, has been carried out by ETSI. No guarantee can be given as to the existence of other IPRs not referenced in ETSI SR 000 314 (or the updates on the ETSI Web server) which are, or may be, or may become, essential to the present document.

Foreword

This Technical Report (TR) has been produced by ETSI Technical Committee Electromagnetic compatibility and Radio spectrum Matters (ERM) in co-ordination with the European Radiocommunications Committee.

Introduction

The present document is a Technical Report on CB radio compatibility.

In producing the present document, significant materials and data on CB use previously available have been considered. Statistical data contained within an ERO report on Citizen's Band Radio in Europe (October 97) has also been considered. The ERO report states that "In all European countries the complaints due to CB operation have decreased considerably during last years". Some interference problems appear to indicate incompatibility between CB 27 MHz radio and TV installations. A new technical approach is requested on this issue.

Taking this into account, the present document has concentrated on a study of the causes of compatibility problems between CB transceivers and TV and FM radio broadcasting reception installations illuminated by an electromagnetic field of 27 MHz. However, radiated immunity tests on broadcasting TV receivers and the influence of different CB type modulations have not been considered in this study. Tests have been made with Amplitude Modulation (AM) in order to check the compatibility concerning TV picture quality.

Previous studies on CB compatibility have included some controversial measurement methods and conclusions. In order to avoid such difficulties, the present document doesn't include measurements by radiation in an anechoic chamber. All tests reported are carried out on open free field measurements sites by official and recognized laboratories.

1 Scope

The present document presents the study on CB 27 MHz radio compatibility with analogue television broadcast receiver installations.

In order to avoid the near field measurement at 27 MHz using reference antennas intended for 50 MHz and more (because the radiated field measurements below 30 MHz are not normally specified) an appropriate 27 MHz dipole antenna has been calibrated to use when necessary.

The study has been carried taking into consideration the field strength level of 125 dB μ V/m as the general limit of immunity to ambient electromagnetic fields at the antennas of TV and FM radio reception installations (CISPR 20 [2], clause 4.1.1).

The present document has two main parts: The study of different each elements of a TV-FM broadcasting installation (clause 5) and the behaviour of the TV installation as a whole (clause 6) when it is illuminated by an electromagnetic field of 27 MHz from a neighbouring site.

2 References

The following documents contain provisions that, through reference in this text, constitute provisions of the present document.

- References are either specific (identified by date of publication, edition number, version number, etc.) or non-specific.
- For a specific reference, subsequent revisions do not apply.
- For a non-specific reference, subsequent revisions do apply.
- A non-specific reference to an ETS shall also be taken to refer to later versions published as an EN with the same number.

- [1] ANSI C63.5 (1998): "American National Standard for Calibration of Antennas used for Radiated Emission Measurements in Electromagnetic Interference (EMI) Control; Calibration of Antennas (9 kHz to 40 GHz)".
- [2] CISPR 20 (1998-08): "Sound and television broadcast receivers and associated equipment-Immunity characteristics – Limits and method of measurement".
- [3] EN 55020 (1994): "Electromagnetic immunity of broadcast receivers and associated equipment".
- [4] UTE C 90-130 (January 1998): "Coaxial cables for individual or central broadcasting reception antennas".
- [5] UTE C 90-124 (July 1991): "Electronic and telecommunication equipment. Individual or community antennas for broadcast reception. Requirements".
- [6] EN 50083-2 (1995): "Cabled distribution systems for television, sound and interactive multimedia signals. Part 2: Electromagnetic compatibility for equipment".
- [7] ITU-R Recommendation BT.500-7 (1995): "Subjective assessment methodology of the quality of television pictures".

3 Definitions, symbols and abbreviations

3.1 Definitions

For the purposes of the present document, the following terms and definitions apply:

Anechoic chamber: a closed room with internal lining to minimize RF reflections as well as external radiation and noise and thus simulating the RF conditions of unobstructed free-field.

Antenna factor: the factor that allows to know, from the voltage registered at the terminals, either the value of the electric field or the value of the magnetic field by the following ratios:

- $A_{fe} = E / U_s$ in m-1 for the electric field.
- $A_{fh} = H / U_s$ in m-1 for the magnetic field.

Antenna gain: ratio generally expressed in decibels between the power required at a reference isotropic loss-less antenna and the power supplied to a given antenna, so that the two antennas produce the same field or the same surface power in a single direction at the same distance. Unless otherwise indicated, this is the maximum gain of the antenna.

Common mode or asymmetrical mode: used for a current, a voltage, a coupling. Two common modes are distinguished:

- The common line mode, a current circulates in the same direction through all the conductors of a cable and is makes the loop by the protective conductor (earth, shield, strip).
- The true common mode, a current circulates in the same direction through all of the conductors of a cable and even the protection cable (earth, shield, strip) and is grounded by capacity and by other cables (connection).

Coupling: transmission mode between a transmitter circuit and a receiver circuit. It may be capacitive or inductive.

Differential mode or symmetrical mode: used for a current, a voltage, a coupling. A current circulates with opposite phase on two conductors of the same cable connection. A potential difference is measured between the forward and return conductor.

Directivity: the ability to transmit or receive a electromagnetic field to or from one direction when reducing or even eliminating those going to or coming from another direction.

Electric field strength: a vector that corresponds to strength exercised independently on a loaded particle of a displacement in the space. It is expressed in volts per metre (V/m).

Electromagnetic disturbance: any electromagnetic phenomenon which may degrade the performance of a device, unit of equipment or system. An electromagnetic disturbance may be electromagnetic noise, an unwanted signal or a change in the propagation medium itself.

Far field: the electromagnetic field when the distance between the transmitter and receiver is more than $\lambda/2\pi$, λ being the wavelength. In a far field, it is considered that the electric field is in square angle to the magnetic field.

Ground plane: element within an installation, which might represent a metal chassis, a collector plate, a mass mesh or a unit, comprising these elements. The ground plane is intended to reduce the shield surface loop and to improve the equipotentiality of the equipment (all parts of the measurements site and the equipment are at the same potential).

Immunity: the ability of a device, unit of equipment or system to perform without degradation of quality in the presence of an electromagnetic disturbance. It is defined by physical quantities (fields, frequencies, current, voltage...) which quantify the degree of immunity of the device, unit of equipment or system.

Semi-anechoic chamber: a closed room with lining on the internal walls and ceiling to minimize RF reflections as well as external radiation and noise and thus simulating the RF conditions of unobstructed free-field. The floor of a semi-anechoic chamber is an RF reflective ground plane.

Transfer impedance: the coupling between the external strip of the coaxial cable and its central wire. It is quantified by the average of virtual impedance.

3.2 Symbols

For the purposes of the present document, the following symbols apply:

Af	Antenna factor
D	Distance in metres
dB	decibel
dB _i	decibel relative to an isotropic radiator
dB _m	decibel relative to one mW
dB _{μV}	decibel relative to one μV
dB _{μV/m}	decibel relative to one μV/m
E	Electric field
G	Gain
GHz	Gigahertz
kHz	kilohertz
MHz	Megahertz
m	metre
V	Volt
W	Watt
λ	Wavelength
μV	microvolt
μV/m	microvolt per metre

3.3 Abbreviations

For the purposes of the present document, the following abbreviations apply:

ac	alternating current
AF	Audio Frequency
A _f n	Factor value of antenna n
AM	Amplitude modulation (A3E)
B I	Band I, for television broadcasting in the VHF range between 47 and 68 MHz
B II	Band II, for FM radio broadcasting in the VHF range between 87,5 and 108 MHz
B III	Band III, for television broadcasting in the VHF range between 174 and 230 MHz
B IV-V	Bands IV and V, for television broadcasting in the UHF range between 470 and 862 MHz
CB	Citizen's Band personal radio 27 MHz
dc	direct current
EM	Electromagnetic
EMC	Electromagnetic compatibility
emf	Electro-motive force.
RF	Radio Frequency
SWR	Standing Wave Ratio
TEM	Transverse Electromagnetic Mode
TVf	TV frequencies
T _x	Transmitter
UHF	Ultra High Frequency (300 to 3 000 MHz)
VHF	Very High Frequency (30 to 300 MHz)

4 Calibration of a CB antenna for reference use

4.1 CB antenna to calibration purpose for reference use

In order to produce an EM field of a known value at 27 MHz for compatibility tests on apparatus or installations, a reference antenna has been used.

Taking into account that there is no small size antenna, for handling purposes, nor calibrated one working on this frequency band, an existing shortened dipole intended for CB use has been calibrated.

The antenna used has been commercialized for 27 MHz CB station purposes for several years and has proved to be entirely satisfactory from the point of view of robustness. Its size of 1,5 m (the normal size of a dipole $\lambda/2$ at 27 MHz is around 5,5 m) and the adaptation to 50 Ω through its built-in self-transformer make it ideal for generating a determinate EM field at 27 MHz.

4.2 Antenna calibration method

The calibration method has been in accordance with ANSI C63.5 [1], and the three-antenna method has been used.

4.3 Results

4.3.1 Gain of the CB antenna

Table 1: Antenna factor and antenna gain of three CB dipoles

Horizontal polarization						
Frequency MHz	Af1 dB	Af2 dB	Af3 dB	G1 dBi	G2 dBi	G3 dBi
26,515	10	10	10	-11	-11	-11
27,205	8	9	9	-9	-10	-10
27,855	9	10	10	-10	-11	-11
Vertical polarization						
Frequency MHz	Af1 dB	Af2 dB	Af3 dB	G1 dBi	G2 dBi	G3 dBi
26,515	12	12	12	-13	-13	-13
27,205	9	8	10	-10	-9	-11
27,855	10	10	11	-11	-11	-12

These results verify that all antenna gains are negative. It is logical given that a shortened dipole has been calibrated.

The gain difference between the two polarizations, 2 dB maximum, enables the results to be validated.

The weak gain of this type of antenna is established. The following equation linking the EM field strength with the RF power supplied to the antenna has been used:

$$E = \frac{\sqrt{30 \cdot P \cdot G}}{D}$$

Where:
 E is the field strength in V/m
 P is the RF power in W
 G is the emitting antenna gain ratio
 D is the distance in m

It has been noted that in order to illuminate an installation at 10 m with an EM field with vertical polarization at 27,205 MHz and 125 dB μ V/m, in accordance with CISPR 20 [2], an RF power of 84 W has to be supplied to the CB antenna 2.

4.3.2 Measurements check up

The gain of antenna 2 has been checked by comparison on the antenna 1, using a reference antenna, see Figure 1.

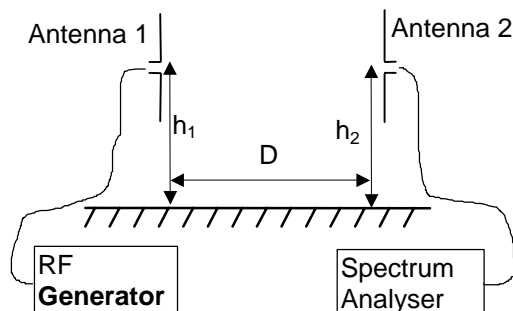

The frequency is 27,205 MHz.

Height h_1 and h_2 are identical (2 m).

Distance $D = 10$ m.

Antenna 1 is the transmitter and antenna 2 is the receiver. The reference antenna then replaces antenna 2 to be calibrated.

Thanks to the reference antenna factor, the value of the received EM field is deduced. Then it is used to determine the antenna gain.

Figure 1

Table 2: Gain of the CB calibrated antenna

Reference antenna		Antenna1		
Af dB	Received level dB μ V/50 Ω	Received level dB μ V/50 Ω	Af dB	G dBi
27	82	100	9	-10

4.4 Comments

The antenna gain deduced by the three-antenna method is -10 dB. Using the reference antenna method it is found to be -10 dB also. In conclusion, these results are considered coherent and are used as the basis for further measurements.

5 Test on different parts of TV-FM radio installations

5.1 Gain at 27 MHz of TV and FM radio reception antennas

5.1.1 TV and FM radio antennas for testing purposes

- TV antenna VHF Band I
- TV antenna UHF Band IV-V
- FM radio antenna VHF Band II bi-polarization horizontal and vertical.

5.1.2 Measurements method and test conditions

The method to measure the gain at 27 MHz of the TV and FM antennas is in accordance with ANSI C63.5 [1], clause 6.

The only working frequency is 27,205 MHz, because it has been deduced that the gain of TV and FM antennas at 27 MHz does not vary excessively on a range of ± 670 kHz (from 26,515 MHz to 27,855 MHz) around its central frequency. The emitted field has vertical polarization.

5.1.3 Results

Table 3: Antenna factor and gain at 27 MHz of TV and FM radio antennas

Antennas	27 MHz EM field lighting TV and FM antennas dB μ V/m	RF level delivered by the antenna dB μ V/75 Ω	Af dB	G dBi
Horizontal polarization of the antennas				
TV VHF B I	109	99	10	-11
TV UHF	109	92	17	-18
FM radio B II	109	93	16	-17
Vertical polarization of the antennas				
TV VHF B I	109	98	11	-12
TV UHF	109	91	18	-19
FM radio B II	109	96	13	-14
NOTE: Results take count of cabling attenuation.				

In order to check these measurements, at first the RF level delivered by the coaxial cable only was measured. To carry out this measurement, the cable was placed in an identical manner to the position in the antenna test. A 75 Ω shielded resistance was connected to the end of the cable. With the same EM reference field of 109 dB μ V/m, the 27 MHz RF level measured on the cable in differential mode by a spectrum analyser was 49 dB μ V. Therefore, the influence of the cabling is negligible in comparison with the 27 MHz RF level delivered by the TV and FM antennas shown in Table 3.

5.1.4 Comments

The gain of these TV and FM antennas at 27 MHz appears to be high. Indeed, taking the immunity EM field level of 125 dB μ V/m (in accordance with CISPR 20 [2]), these antennas may deliver a level at 27 MHz which is too high compared with the limits of input immunity of TV receivers in accordance with EN 55020 [3], clause 9.2, Table 7 (quoted in Table 4 of the present document). The 27 MHz RF levels developed by the TV and FM antennas under test conditions are shown in Table 5.

Table 4: Limits of input immunity of television receivers in EN 55020 [3]

TV bands	Limits of input immunity dB μ V/75 Ω	Unwanted signal frequency MHz
VHF B I	89	26 - 30
VHF B II	No limit indicated	No limit indicated
VHF B III	104	26 -30
UHF B IV-V	No limit indicated	No limit indicated

Table 5: RF 27 MHz level delivered by TV & FM antennas at the EM field immunity limit of 125 dB μ V/m

Frequency Band MHz	Antennas	EM field illuminating antennas dB μ V/m	Af dB	RF level delivered by the antenna dB μ V/75 Ω	Limits of input immunity (EN 55020 [3]) dB μ V/75 Ω
Horizontal polarization of TV antennas					
47 to 68	TV VHF B I	125	10	115	89
174 to 230	No test				104
470 to 862	TV UHF	125	17	108	—
Vertical polarization of FM antennas					
87,5 to 108	FM radio	125	13	112	—

5.2 27 MHz RF level delivered by the TV antenna

The aim of this test is to evaluate the mechanism of coupling between the electromagnetic field developed by CB installation and a single TV installation. The test estimates the maximum coupling to a TV installation produced by a CB fundamental frequency (27 MHz) or harmonic frequencies.

5.2.1 TV antenna and equipment for testing purposes

To realize a typical electromagnetic environment, the products as follows have been used:

- The signal source was an old CB set, installed in a car with a CB antenna on the roof (1,5 m above the ground), working at frequency of 27,205 MHz.
- Receiver TV installation: a measured truck with a typical TV antenna mounted on a 15 m mast, and oriented towards the CB antenna.
- Distance: 135 m between both installations on a free field.

5.2.2 Measurement method and test conditions

- First, the RF output power of the CB transmitter at frequencies 27,205 MHz and its harmonics were measured with the CB equipment set on a 50 Ω load.
- Second, a typical configuration of electromagnetic disturbances between a CB installed in a car and a TV installation with an antenna on a mast was simulated.
- Third, the RF level was measured on TV antenna connector.

5.2.3 Results

The measured fundamental RF output power of the CB transceiver set used is 35,5 dBm.

The harmonic levels measured at 50 Ω load on the RF output connector of the CB equipment is given in Figure 2.

The level measured at 75 Ω load on the TV antenna connector at 27,205 MHz signal and its harmonics are given in Table 6.

Table 6: Level of 27 MHz and harmonics delivered by the TV antenna

Frequency (MHz)	CB RF level measured on TV antenna connector in dB μ V			
	VHF Horizontal polarization	VHF Vertical polarization	UHF Horizontal polarization	UHF Vertical polarization
27,205	Mast at 4 m: 78 dB μ V Mast at 15 m: 75 dB μ V	Mast at 4 m: 70 dB μ V Mast at 15 m: 66 dB μ V	Mast at 15 m: Not significant (Below 10 dB μ V)	Mast at 15 m: 61 dB μ V
54,41	Not significant (below 10 dB μ V)			
81,615				
108,82				
163,23				
408,075				

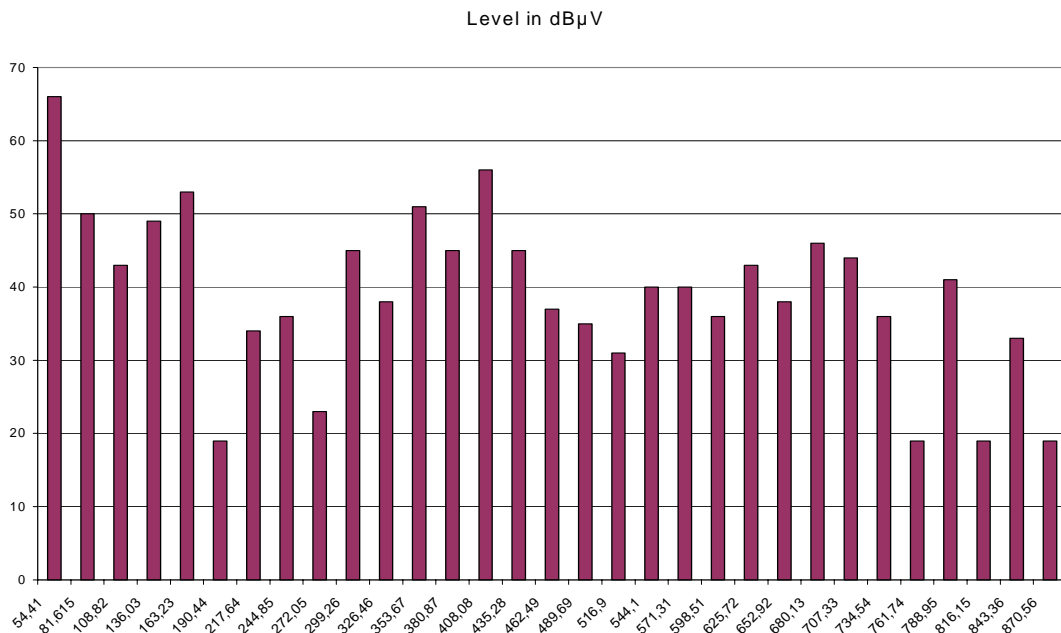

Figure 2: Emissions at harmonic frequencies of a 27 MHz CB radio (54,41 MHz to 870,56 MHz)

5.2.4 Comments

No significant level of harmonics at user connector TV set. Only the fundamental frequency of 27 MHz appeared at the antenna connector. In consequence, all compatibility tests have done to check the effects of the fundamental frequency of 27 MHz.

5.3 Induced RF 27 MHz on the TV antenna cable

Testing the coaxial cable immunity requires high important equipment in accordance with UTE C 90-130 [4]. It has been considered that it is not necessary to measure the screening efficiency of a 75 Ω coaxial cable, usually provided by the manufacturer. However its behaviour in an EM field at 27 MHz should be verified, under conditions as close as possible to normal use.

5.3.1 Non ground referenced load cable

5.3.1.1 Measurement method and test conditions

As the RF induced by coupling to the central conductor is directly proportional to its length, tests were carried out on a section of cable of length $\lambda/2$ ($\lambda = 11$ m) in order to find the maximum induction effect of the 27 MHz EM field.

The 5,5 m coaxial cable total, terminated in a 75Ω resistive load, was stretched out horizontally at 2 m height above the ground plane by using a PVC tube.

The reference transmission antenna was the shortened antenna 3 previously calibrated, see clause 4. The RF power applied to this antenna was 30 dBm. The distance between the cable under test and the transmission antenna was 10 m (see Figure 3).

The EM field strength was 109 dB μ V/m on the plane where the cable was placed.

The propagation speed of the signal in the cable is not the same as the speed of light. In consequence the frequency of the disturbance field was swept around the frequency of 27 MHz (resonance seek) in order to find the maximum induced level.

At a first stage, in order to measure the RF level induced in 27 MHz by coupling, a shielded resistor of 75Ω was connected to one end, and a spectrum analyser was connected to the other. The input of the spectrum analyser was programmed at 75 Ω .

At a second stage, the previous configuration was conserved, but with a ground breakage carried out with a joint using male and female cards. This break was placed in the middle of the horizontal part of the cable.

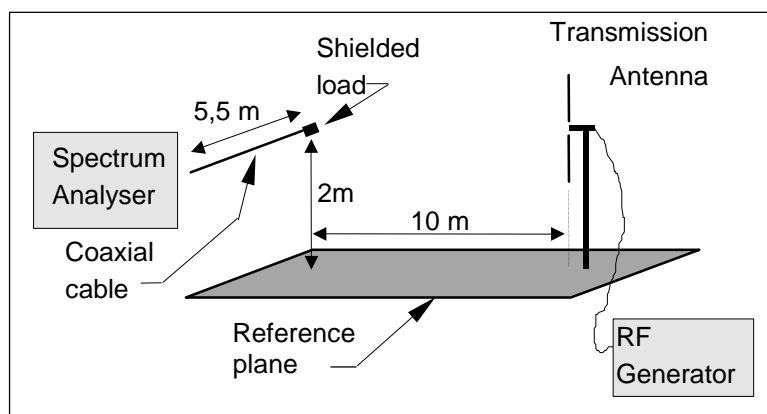

Figure 3: Test layout for non ground referenced TV cable

5.3.1.2 Results

Table 7: 27 MHz RF level collected by a non ground referenced TV cable

Polarization of the transmission antenna	Measurements	Maximum collected level dB μ V/75 Ω
Vertical & Horizontal	Spectrum analyser alone with a charge adapted to the inlet	No signal above the internal noise of the analyser
Horizontal	Without ground breakage	40
	With ground breakage	50
Vertical	Without ground breakage	42
	With ground breakage	52

5.3.2 Ground referenced load cable

5.3.2.1 Measurement method and test conditions

The cable was still set out 2 m above the floor, but this time the ground was linked to the reference plane beside the spectrum analyser and the end resistive load was 75 Ω .

The distance between the cable under test and the transmission antenna was 10 m, as specified in subclause 5.3.1 (see Figure 4).

The EM field strength, as specified in subclause 5.3.1, was 109 dB μ V/m on the plane where the cable was placed.

The tests were conducted with a ground breakage as specified in subclause 5.3.1.

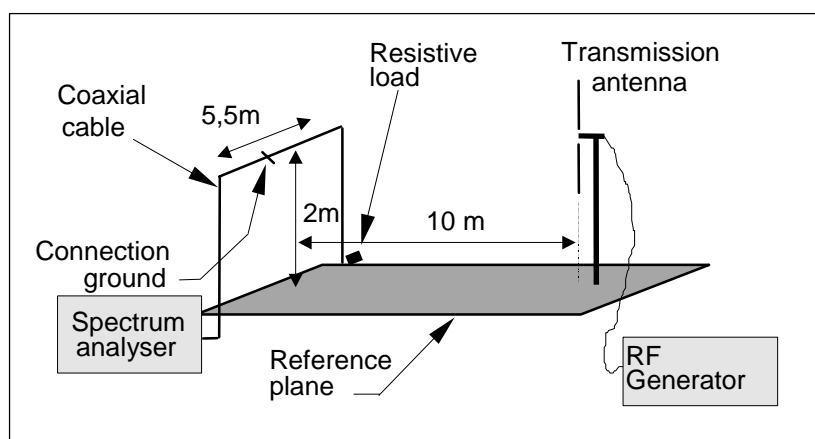

Figure 4: Test layout for ground referenced TV cable

5.3.2.2 Results

Table 8: 27 MHz RF level collected by a ground referenced TV cable

Polarization of the transmission antenna	Measurement	Maximum collected level dB μ V/75 Ω
Vertical & Horizontal	Spectrum analyser alone with a charge adapted to the inlet	No signal above the internal noise of the analyser
Horizontal	Without ground breakage	58
	With ground breakage	56
Vertical	Without ground breakage	49
	With ground breakage	58

5.3.3 Comments

Results show that the cable only develops a small signal at 27 MHz in comparison with the levels obtained from the TV and FM antennas terminals. In fact, the most significant result in Table 3 is the level of 99 dB μ V, while it is only 58 dB μ V in Table 8. The real difference is 41 dB (ratio of 100 approximately).

On the other hand, further interesting elements of this test can be noted:

- The first obvious point is that the polarization of the field does little to modify the level received by the cable. By contrast, the ground breakage increases this same level by 10 dB, which confirms that an installation must have a direct link and it also confirms that the interconnections have to be strictly limited.

- A priori, the reference (shielding harness) connected to the ground plane reduces the immunity of the cable by almost 18 dB in the worst case. However, cautions have to be taken on this interpretation. In fact, with a working wavelength of 11 m, in this set-up by linking the shielding harness with the reference plane, the layout forms a loop that may induce an influence through the magnetic composition of the field. In this case it can be seen that the ground breakage caused by the connector does not affect the behaviour of the cable in any way when it is illuminated by a horizontally polarized field, whereas this same breakage increases the level received by 10 dB in vertical polarization.

5.4 Immunity of TV and FM radio antenna amplifiers to 27 MHz

This test has been carried out to measure the true bandwidth and characteristics of real TV and FM radio antenna amplifiers and also to check their immunity on a real site in the presence of a 27 MHz EM field.

5.4.1 Bandwidth and selectivity

5.4.1.1 Antenna amplifiers for testing purpose

Four TV and FM amplifiers, provided with a power supply according to the specification given by their manufacturers, were powered by 24 V.

TV – FM antenna amplifier 1:

- Wide band amplifier 47 - 862 MHz TV B I, B III, B IV-V and FM radio B II
- Two-way connector VHF - UHF
- Gain 27 dB

TV - FM antenna amplifier 2:

- Wide band amplifier 47 - 862 MHz TV B I, B III, B IV-V and FM radio B II
- Two-way connector VHF – UHF
- Gain 26 dB

TV antenna amplifier 3:

- TV B III, B IV-V
- Two input amplifier
- Gain BIII 29 dB max. B IV-V 34 dB max.

TV antenna amplifier 4:

- TV B III, B IV-V
- Two input amplifier
- Gain BIII 28 dB max. B IV-V 36 dB max.

5.4.1.2 Measurements method and test conditions

Each amplifier was powered by its own power supply. The coaxial cable was of the same type as the one tested before (subclause 5.3) and the various lengths were reduced to a strict minimum. The amplifiers, which have adjustable gain, were adjusted for maximum gain.

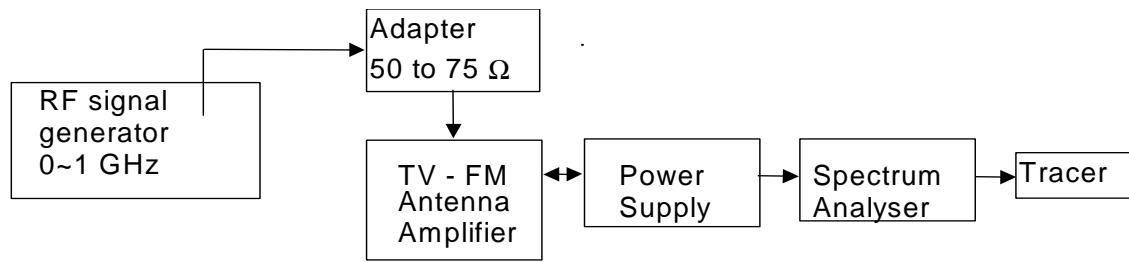

Figure 5: TV antenna amplifiers bandwidth measurements layout

5.4.1.3 Results

The RF bandwidths of the antenna amplifiers are shown in Figures 6 to 13 hereafter. Measurement conditions and results are quantified in embedding notes to the Figures. Summarized gain results are given in Table 9.

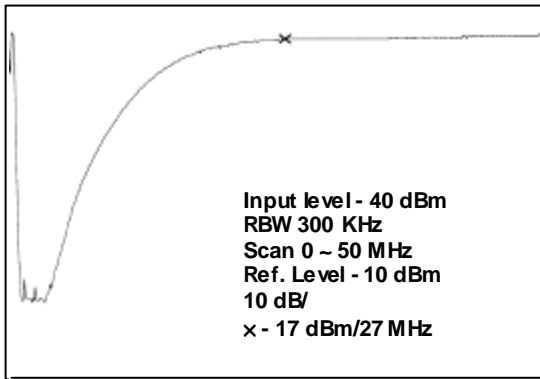

Figure 6: Amplifier 1. VHF-UHF. 0 to 50 MHz

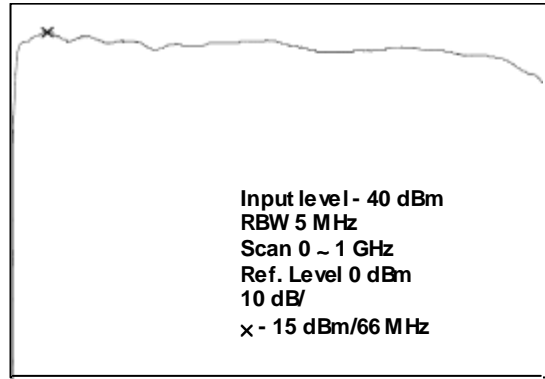

Figure 7: Amplifier 1. VHF-UHF. 0 to 1 GHz

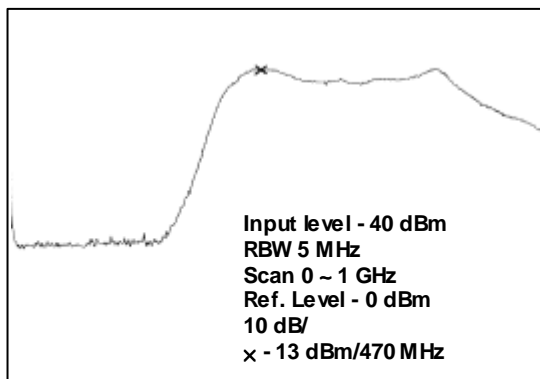

Figure 8: Amplifier 2. UHF. 0 to 1 GHz

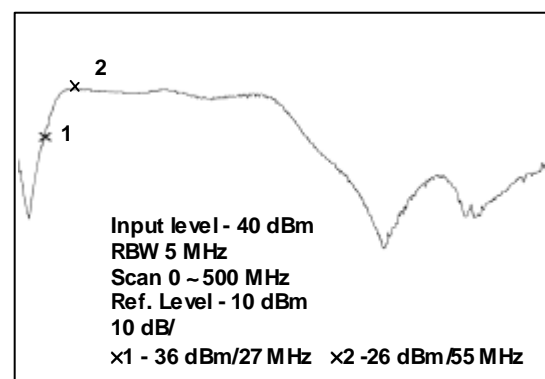

Figure 9: Amplifier 2. VHF. 0 to 500 MHz

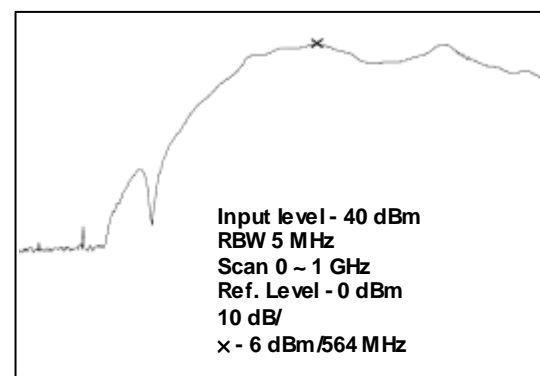

Figure 10: Amplifier 3. UHF. 0 to 1 GHz

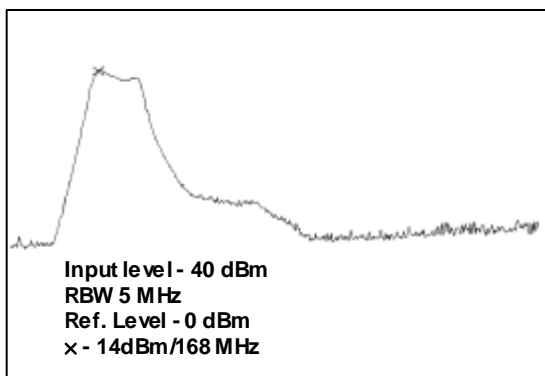

Figure 11: Amplifier 3. VHF. 0 to 1 GHz

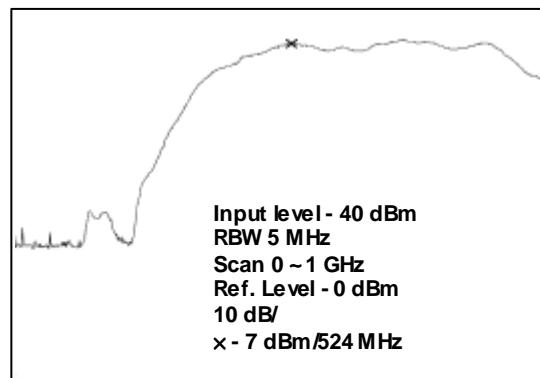

Figure 12: Amplifier 4. UHF. 0 to 1 GHz

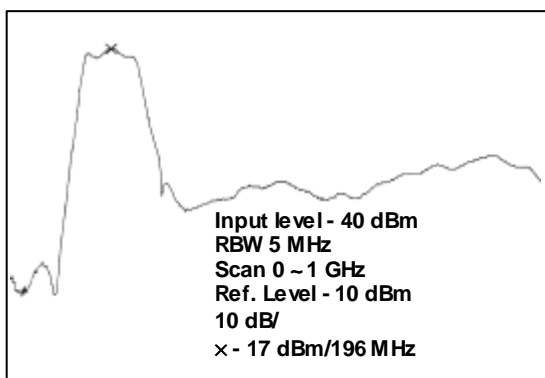

Figure 13: Amplifier 4. VHF. 0 to 1 GHz

Table 9: Summarized TV antenna bandwidth and gain at 27 MHz

Amplifiers under test	Nominal gain (dB)		Measured gain (dB)		Gain at 27 MHz (dB)	
	UHF	VHF	UHF	VHF	UHF	VHF
Amplifier 1	27		25		23	
Amplifier 2	-	-	27	14	-	4
Amplifier 3	34	29	34	23	-98	-28
Amplifier 4	36	28	33	26	-77	-32

5.4.1.4 Comments

First of all it was noted that the measured gains are essentially the same (to within a few dB) as the gains advertised by the manufacturers.

On the other hand, the rejection or attenuation of the 27 MHz frequency is non-existent in two amplifiers; which amplify themselves the 27 MHz RF level received:

- The wide band antenna amplifier produces 23 dB gain at 27 MHz.
- Antenna amplifier 2, VHF input, produces 4 dB at 27 MHz.

It is also noted that the European standard for this apparatus doesn't establish compatibility limits on its behaviour at 27 MHz or, more generally speaking, in the 26 to 30 MHz band. Some European countries have a national standard for electromagnetic compatibility for this apparatus, which gives specific selectivity or attenuation requirements for signals at unwanted frequencies.

5.4.2 External immunity to a surrounding 27 MHz EM fields

5.4.2.1 Antenna amplifier for testing purpose

This measurement has been targeted at the amplifier that produces the highest gain at the frequency of 27 MHz. This is the wide-band amplifier 1 (see Figures 6 and 7 and Table 9).

5.4.2.2 Measurement method and test conditions

Measurements on external immunity to surrounding fields require the use of a Transverse Electromagnetic Mode (TEM) cell in undisturbed surroundings.

The incident 27 MHz EM field was generated in the TEM cell by the signal from the 27 MHz generator, AM modulated at 80% depth by an 1 kHz audio frequency. The level of the incident EM field was 125 dB μ V/m.

Another RF generator supplied the wanted signal at TV frequencies. Its level was adjusted so that the output level of the antenna amplifier under test wouldn't be higher than the one established in accordance with EN 50083 [6].

As the TEM cell has a characteristic impedance of 150 Ω , an impedance adapter was connected between the cell and the 50 Ω coaxial cable (see Figure 14). The TEM cell was terminated with a resistor of 150 Ω .

The resulting 27 MHz level delivered by the antenna amplifier and the intermodulation products in the same TV frequency band were measured with the spectrum analyser. The notified laboratory and competent body where the tests were made proceeded in accordance with EN 50083 [6], subclause 4.3, and the testing method was set out in accordance with EN 55020 [3], clause 13.

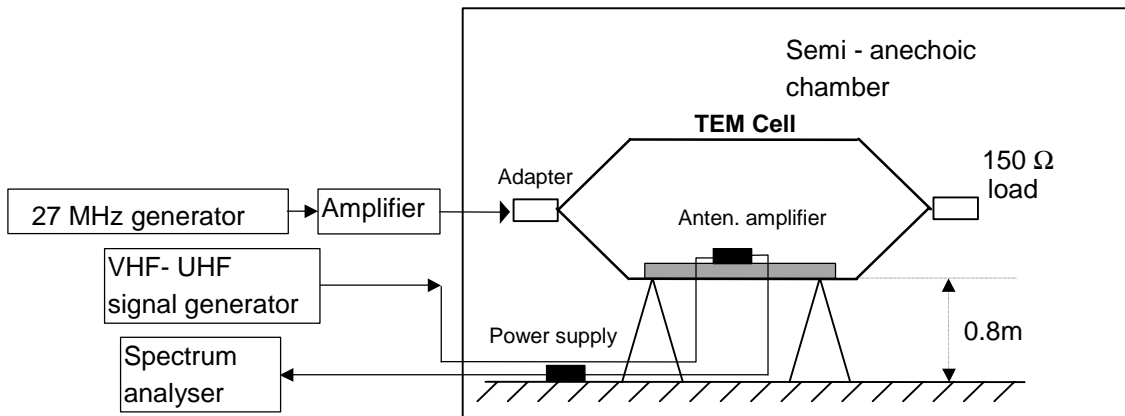

Figure 14: Test conditions layout for surrounding 27 MHz EM fields

5.4.2.3 Results

Table 10: Delivered levels at the antenna amplifier output

Frequency HF-VHF-UHF Generator MHz	Output level at TV frequencies (TVf) dB μ V/75 Ω	Intermodulation products frequency (TVf + 27 MHz)	Output level at 27 MHz dB μ V/75 Ω	TVf/27 MHz ratio dB
27	-	-	49	-
176	74	203	1	73
472	74	499	16	58
600	74	627	14	60

In order to carry out this test in accordance with EN 50083 [6], the gain should be adjusted to maximum. However, this study was not intended to determine the conformity of the tested products with EMC standards. The purpose was to check the behaviour of these materials illuminated by a 27 MHz signal. It was decided to verify the behaviour with different gain adjustments, in order to simulate a real case more precisely. The output signal was maintained constant. These complementary results are in Table 11.

Table 11: Delivered levels at the antenna amplifier output for different gain

Adjusted antenna amplifier gain dB	Frequency UHF Generator MHz	Output level at TV frequencies (TVf) dB μ V/75 Ω	Intermodulation products frequency (Wf + 27 MHz)	Output level at 27 MHz dB μ V/75 Ω	TVf/27 MHz ratio dB
20	600	74	627	26	48
15	600	74	627	24	50
10	600	74	627	21	53

5.4.2.4 Comments

Regarding the 27 MHz level measured at the amplifier output (49 dB μ V), this level is very weak given its direct gain at the same frequency by conduction (23 dB) see Table 9.

It was noted that TV antenna amplifier is not in compliance with the related standard. However, this was not the purpose of the measurement.

NOTE: The adjustment gain of this amplifier is carried out by means of a potentiometer placed close to the input connection. This is therefore easily accessible even to unskilled users.

5.4.3 External immunity to 27 MHz signal through the connection cable

5.4.3.1 Antenna amplifiers for testing purpose

Initially, the following antenna amplifiers described in 5.4.1.1 were taken for this test:

- TV antenna amplifier 3
- TV antenna amplifier 4
- TV-FM antenna amplifier 1

5.4.3.2 Measurements method and test conditions

The injection of an unwanted signal in the connected cables of a device, using a suitable injection network by conduction, simulates the effects of induced RF unwanted signals on the cables in a real installation.

The normal layout and measurements method were in accordance with EN 55020 [3].

The signal injections were made on the input, on the output, and on the main power line using injection networks.

In accordance with EN 50083 [6] the level of the unwanted signal at 27 MHz was 126 dB μ V emf.

In accordance with UTE C 90-124 [5] the level of the wanted signal was 60 dB μ V.

The delivered levels of the 27 MHz unwanted signal and the intermodulation products in the amplifier working band were measured by a spectrum analyser.

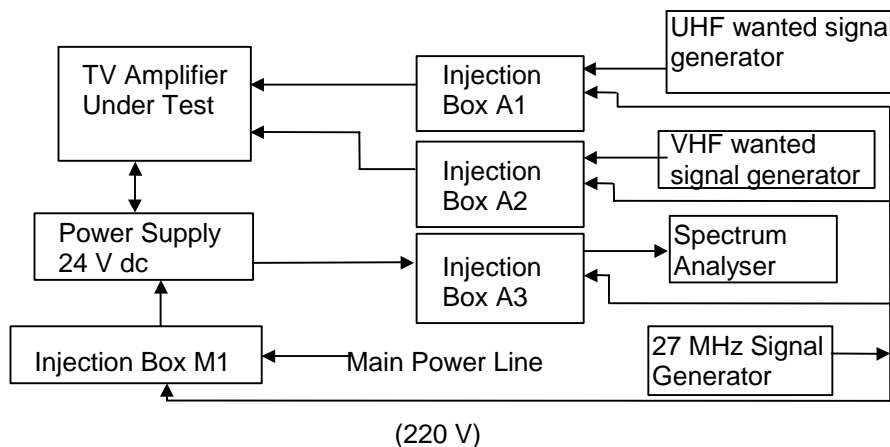

Connections to the amplifier:

UHF input by Box A 1

VHF input by Box A 2

Output by Box A 3

Main power line by Box M 1

Figure 15: Test layout for 27 MHz signal through the connection cables

5.4.3.3 Results

Table 12: Delivered levels at the antenna amplifier output

Sets under test	Frequency VHF-UHF generator MHz	Output level at TV frequencies (TVf) dB μ V/75 Ω	Intermodulation products frequency (TVf + 27 MHz)	Output level at 27 MHz dB μ V/75 Ω	TVf/27 MHz ratio dB
Amplifier 3	176	60	203	< 0	> 60
	600	60	627	< 0	> 60
Amplifier 4	176	60	203	< 0	> 60
	600	60	627	< 0	> 60
Amplifier 1	176	60	203	< 0	> 60
	600	60	627	< 0	> 60

5.4.3.4 Comments

The level of the intermodulation product of 0 dB μ V corresponds to the noise level on the spectrum analyser. The reading dynamics were 60 dB, which is the limit prescribed by the standard. It can not therefore be said that there is no intermodulation product, but it simply stated that the protection ratio is above 60 dB, if there is one.

Regarding the measurement level at 27 MHz, the normal test layout described in Figure 15 has not to been used. Because the TV apparatus and accessories are not often tested in laboratory, the normal injection networks do not allow sufficient blockage to the 27 MHz signal towards the wanted signal generators. Without knowing the rejection in common mode of the generators, it is very difficult to assess the effect of the level brought in by the generator. Furthermore, the coaxial cable connecting the injection boxes to the amplifier under test also influences the disturbance level at 27 MHz.

The injection networks were therefore tested alone in order to check their behaviour and the results confirm the uncertainties previously mentioned. Indeed, the unwanted signal varies from 37 to 68 dB μ V depending on the box set-up.

5.4.3.5 Complementary measurements

It was decided to proceed in a different manner from that described in EN 55020 [3], injecting the unwanted 27 MHz signal not by means of injection networks, but directly into the amplifier, thereby preventing parasitic couplings.

The test layout and cabling was carried out as shown in Figure 16.

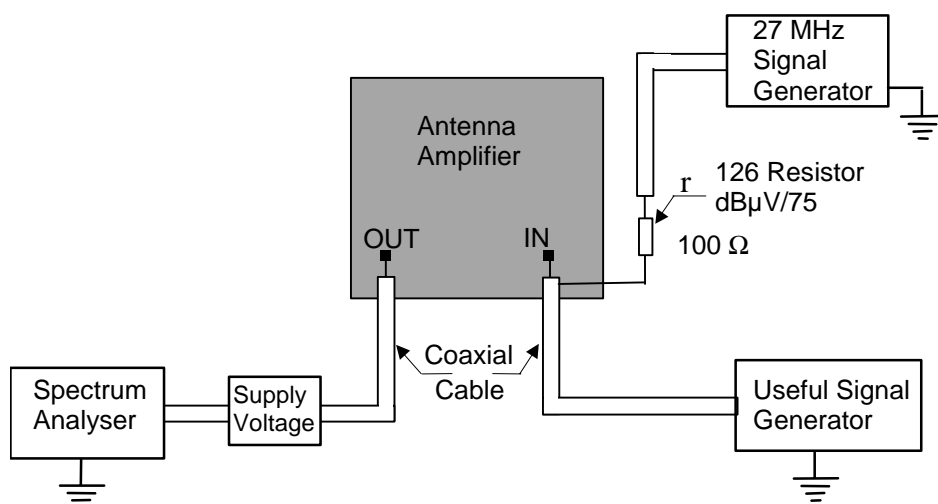

Figure 16: Test layout for the complementary measurements

The complementary measurements were only carried out on the wide-band antenna amplifier 1 and these are reported hereafter.

The 27 MHz unwanted signal was directly injected to the ground of the amplifier:

The resulting the 27 MHz output amplifier level measured by the spectrum analyser was 101 dB μ V/75 Ω . This level was considered rather high. In consequence it was decided to carry out counter-checks so the input coaxial cable was disconnected from the end of the wanted signal generator. Preventing any current from circulating in the strip (insulated from ground) the coupling by the transfer impedance along this cable was eliminated. The 27 MHz output level was the same as at the first measurement (101 dB μ V/75 Ω).

The amplifier supply was switched off:

The 27 MHz level on the spectrum analyser fell to 50 dB μ V/75 Ω . This time, the level is the correct one of coupling by transfer impedance of the output cable. This output level is insignificant in regard the one when the power supply was switched on.

The central wire of the output coaxial cable was disconnected while the power supply was switched on:

The 27 MHz output level was 50 dB μ V/75 Ω . The connection of the input coaxial cable to the wanted signal generator was re-established: The output signal returned to the initial level of 101 dB μ V/75 Ω .

These complementary measurements validate that the 27 MHz RF level (101 dB μ V/75 Ω) is delivered by the antenna amplifier.

5.4.3.6 Comments

The conformity of the external immunity of this product with the current conducted along the connection cables in the strict methodology described by the applicable standard EN 55020 [3] has been noted. Also, the 27 MHz level that this amplifier brings to its output (101 dB μ V/75 Ω) seems too high in order to achieve electromagnetic compatibility, although this is not taken into account in the standards.

5.5 TV sets immunity test with a 27 MHz signal by conduction

5.5.1 Laboratory test

5.5.1.1 Measurement method and test conditions

Three different television sets were used.

A colour bar generator was used to provide a TV signal of 70 dB μ V in Band I and 74 dB μ V in Band III and also in Band IV-V.

The 27 MHz generator was AM modulated to a depth of 80% by a 1 kHz AF signal as prescribed in EN 55020 [3].

According to the results in reported in subclause 5.2, all tests were made carefully to eliminate the 27 MHz harmonics.

The evaluation of the observed picture degradation (Figure 18) was set up in accordance with ITU-R Recommendation BT. 500-7 [7]. The 27 MHz RF levels causing perceptible picture degradation were noted.

The following tests have been carried out:

- Internal immunity in differential mode (normal conduction)
- Internal immunity in common mode

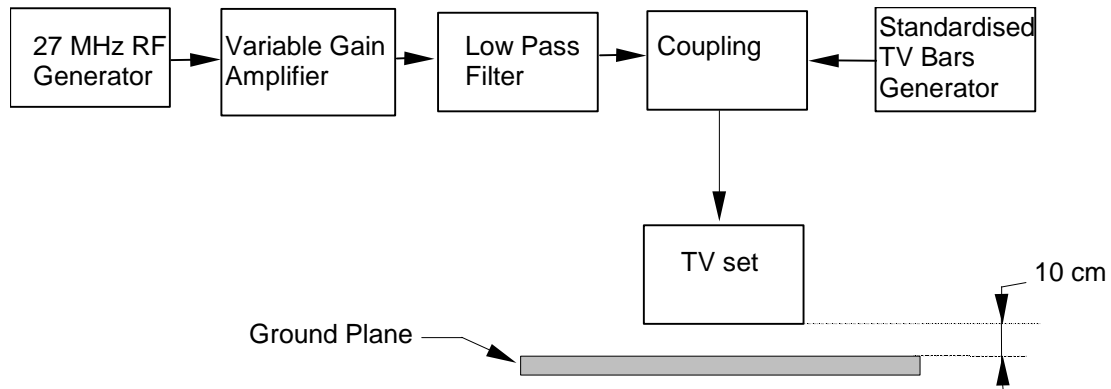

Figure 17: Immunity test layout in laboratory

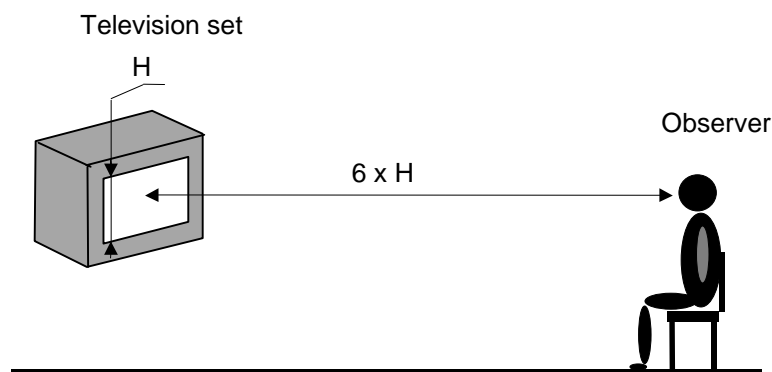

Figure 18: Picture degradation observation plan

5.5.1.2 Results

Table 13: TV sets immunity levels to 27 MHz signals in laboratory

TV sets	Test frequency MHz	27 MHz RF level to causing perceptible picture degradation				
		Differential mode dB μ V/75 Ω			Common mode dB μ V emf.	
		Ch 02 B I	Ch 08 B III	Ch 55 B V	Ch 02 B I	Ch 55 B V
TV set 1	26,515	107	106	106	142	142
	27,205	102	103	104	135	135
	27,855	101	107	107	142	142
TV set 2	26,515	104	107	102	139	139
	27,205	96	109	103	137	137
	27,855	98	106	105	138	138
TV set 3	26,515	108	110	102	134	134
	27,205	102	111	102	134	133
	27,855	98	108	101	133	134

5.5.1.3 Comments

The laboratory test confirms that picture degradation occurs in the presence of a 27 MHz unwanted signal (at a few dB more or less) on the three TV bands. But the standard EN 55020 [3] doesn't set limits in the UHF bands IV and V (see Table 4 in subclause 5.1.4). This behaviour could be produced by intermodulation phenomenon.

The immunity levels of the three tested TV sets are in compliance (at limit) to the limits of input immunity in the standard EN 55020 [3]. But this standard doesn't set limits in the UHF bands IV and V (see Table 4).

The immunity level difference between differential and common mode confirms that the disturbance comes through the central wire of the coaxial cable.

5.5.2 Test in a real TV receiving site with a 27 MHz AM signal

5.5.2.1 Measurement method and test conditions

Nine different television sets and five video tape recorders were used for this test.

In order to maintain the coherence of the procedure used to evaluate the picture degradation (see Figure 18) the test was performed in accordance with ITU-R Recommendation BT. 500-7 [7].

The method used to measure the internal immunity described in EN 55020 [3] prescribes the use of a standard colour bar generator, producing a wanted signal of 70 dB μ V in the VHF bands and 74 dB μ V in the UHF band.

Considering:

- 1) that these levels are rarely reached in the most common television reception installations,
- 2) that the test conditions are always the worst possible (general criterion of electromagnetic compatibility tests),
- 3) that a fixed colour bar picture doesn't correspond to the current moving pictures seen on television programme,
- 4) that the generation of a video signal by a pattern generator is not representative as it does not reproduce the multitude of signals of different levels usually present at a user terminal and therefore it is unable to reproduce any possible beating interference,

it has been decided to work with video signals received by a real installation, which are present at a user terminal in order to guarantee reception of sufficient quality. Also with a view to working in conditions as close as possible to reality, the various picture degradation tests have been carried out on different TV programmes, with the received video signal.

Regarding the CB transceiver used as a 27 MHz AM source, a special laboratory model was chosen in preference to a commercial model, in order to guarantee a power of 42 dBm (16 W PEP). The reference level of the audio-frequency signal modulating the carrier was adjusted to produce an amplitude modulation of 100%. The source of the AF modulation was a spoken voice (discontinuous signal) audio tape recorder.

The 27 MHz RF levels causing a perceptible degradation on the picture were measured by spectrum analyser and noted.

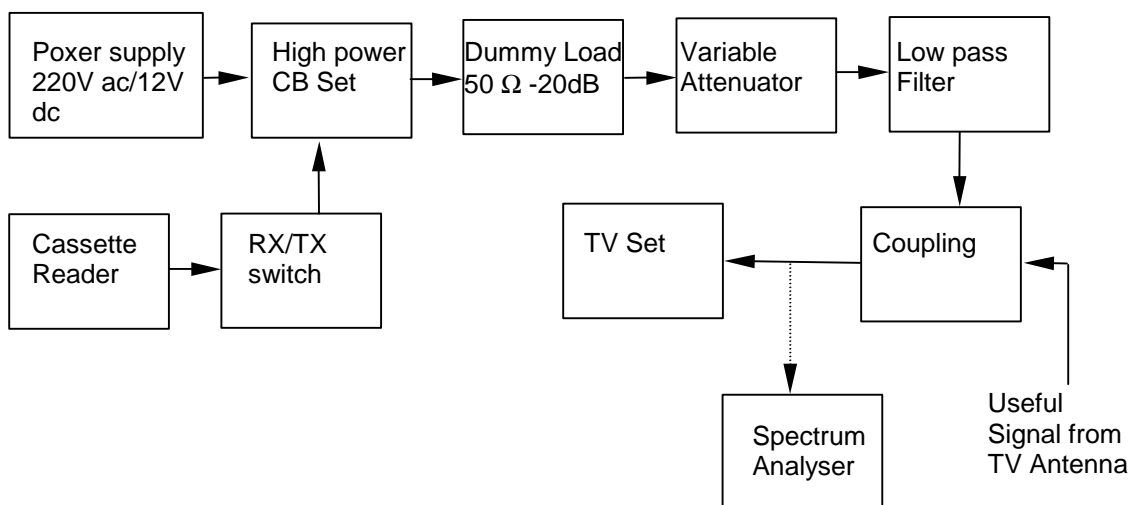

Figure 19: Immunity test layout in a real site

5.5.2.2 Results

Table 14: TV and video tape recorders set immunity level to 27 MHz in a real site

Test number	Conditions of the TV installation	Apparatus under test	Year of purchase	Useful signal levels dB μ V/75	27 MHz level for picture degradation dB μ V	27 MHz level for sound degradation dB μ V
1	Private installation with antenna amplifier	TV 4	97	56 - 66	>132	>132
2	Collective installation	TV 5		59 - 74	121	128
		Video rec. 1			118	-
3	Private installation with antenna preamplifier	TV 6	97	61 - 68	>132	>132
4	Private installation with antenna preamplifier	TV 7	<93	50 - 58	127	-
		Video rec. 2	<90	50 - 58	108	115
5	Private installation without antenna preamplifier	TV 8	11/97	47 - 73 52 - 73 47 47 - 3	(26,515 MHz) 120 (27,205 MHz) 116 (27,205 MHz) 110 (27,855 MHz) 121	>132
		Video rec. 3	94	47 - 73	>132	>132
6	Private installation without antenna preamplifier	TV 9	08/97	53 - 74	>132	>132
7	Private installation without antenna preamplifier	TV 10	97	51 - 73	>132	>132
8	Private installation without antenna preamplifier	TV 11	11/96	53 - 70	>132	>132
		Video rec. 4	97	53 - 70	(26,515 MHz) 122 (27,205 MHz) 129 (27,855 MHz) 128	(26,515 MHz) 122 (27,205 MHz) 129 (27,855 MHz) 128
9	Private installation with antenna preamplifier + amplifier	TV 12	97	56 - 68	>132	>132
		Video rec. 5			122	132

NOTE 1: The wanted signal levels are the boundaries between the lowest and the highest wanted signal levels.
NOTE 2: The used TV channels are between channels 48 and 53 in the UHF band and channel 02 in VHF band I.

5.5.2.3 Comments

At first, it was verified that the picture degradation level was higher than sound degradation. In any case, whenever there is picture degradation, it occurred in all channels of UHF and VHF band. Similarly, the degree of the picture degradation was constant.

Overall, when the degradation was visible on the TV screen, if the 27 MHz signal carrier frequency was changed to the extremes, there was no notable change in the amount of picture degradation. In fact, the central frequency on test 5 was the one that seemed the most disturbing (between 11 and 4 dB with respect to extreme frequencies) whereas in test 8, the lowest frequency was the most disturbing.

All tested televisions and tape recorders complied with the applicable immunity standard EN 55020 [3] at the limits unwanted signals of 89 dB μ V/75 Ω for Band I and 104 dB μ V/75 Ω for Band III.

NOTE: The internal immunity limit on the frequency of the unwanted signal from 26 MHz to 30 MHz is not indicated in standard EN 55020 [3] for UHF (bands IV - V).

6 Complete TV installation illuminated by a 27 MHz field

6.1 Test in free field measurements site

6.1.1 Materials for testing purpose

With the materials tested in subclauses 5.1 and 5.4, four TV installations has been set up and tested one by one:

- Installation 1. VHF + UHF + FM radio antennas + coupling + wide band amplifier 1
- Installation 2. VHF + UHF antennas + coupling + amplifier 2
- Installation 3. VHF + UHF antennas + coupling + amplifier 3
- Installation 4. VHF + UHF antennas + coupling + amplifier 4

6.1.2 Measurement method and test conditions

The level of the EM field at 27 MHz, as in previous tests, was set at $109 \text{ dB}\mu\text{V/m}$ and the frequency at 27,205 MHz.

The gain of the antenna amplifiers was adjusted to a maximum and they were powered by their own supply voltage.

The behaviour of the cable system was checked by replacing the antennas by a 75Ω resistor. The levels observed in this set-up were insignificant compared to the levels observed when antennas were used.

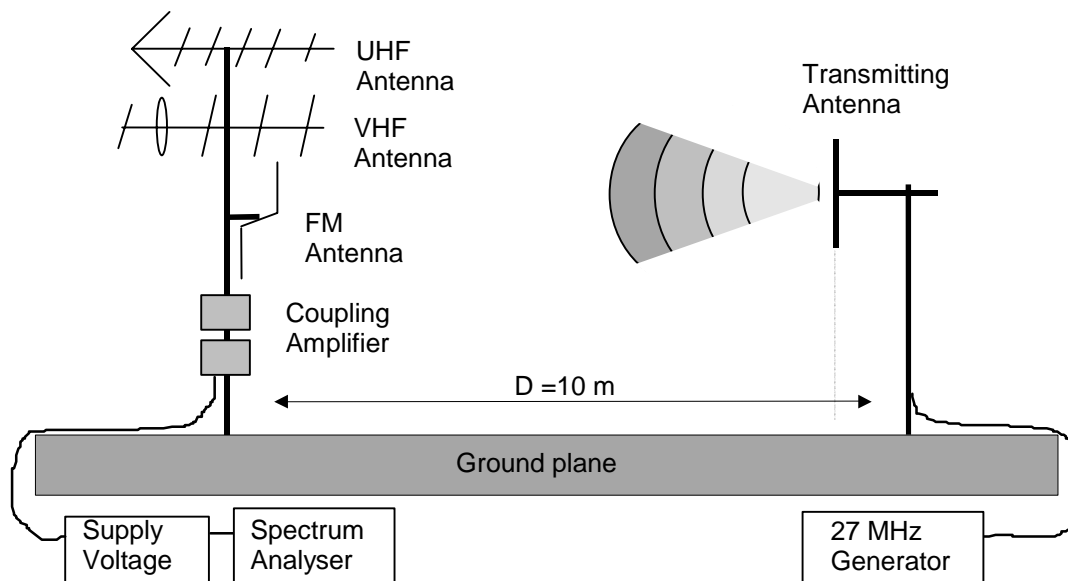

Figure 20: Test layout for complete TV installation test in a free field measurements site

6.1.3 Results

Table 15: 27 MHz RF level delivered by four complete TV installations (in dB μ V/75 Ω)

	TV installation 1	TV installation 2	TV installation 4	TV installation 3
TV Bands	I – II – III – IV - V	I – III – IV - V	III – IV - V	III – IV - V
27 MHz delivered level for a109 dBμV/m EM field	112	82	53	57
27 MHz extrapolated level for a125 dBμV/m EM field	128	98	69	73

6.2 Test on real conditions in a residence site

6.2.1 Measurements method and test conditions

With materials tested in subclauses 5.1 and 5.4, two TV installations have been set up and tested. The most susceptible amplifier was used in both installations.

- Installation 1: VHF + UHF + FM radio antennas + coupling + wide band amplifier 1.
- Installation 2: VHF + FM radio antennas + wide band amplifier 1.

The antennas were oriented in the direction of the disturbing signal and the amplifier gain was adjusted to the maximum.

The received 27 MHz signal level was measured inside the house on the wall antenna connector by a spectrum analyser with input impedance set to 75 Ω .

The source of 27 MHz EM field was placed around 20 m from the TV and FM reception antennas (Figure 21).

This field was produced using the following material:

- A car CB antenna, with a total length of 1,5 m, provided with an impedance transformer in the base.
- This antenna was placed on the roof of a car at 20 m from the TV and FM radio reception antennas (Figure 21).
- A carrier CB set with an adjustable output power from 1 W to 4 W, which fed a power amplifier able to deliver 60 W into a 50 Ω load.

The tested SWR of the CB antenna on the car was 1,2 (good impedance adaptation) at the working frequency.

The power level of the CB equipment was adjusted in order to obtain an EM field at 27 MHz of 125 dB μ V/m on the plane of the TV and FM antennas. A measurement antenna and spectrum analyser were used to measure the EM field strength.

It was noted that, in order to reach the limit EM field prescribed (125 dB μ V/m), it was necessary to use a high transmission power of 60 W. In relation to the equation 1 in subclause 4.3.1, it is found -1,5 dB gain for the transmitting CB antenna, which is coherent given its length.

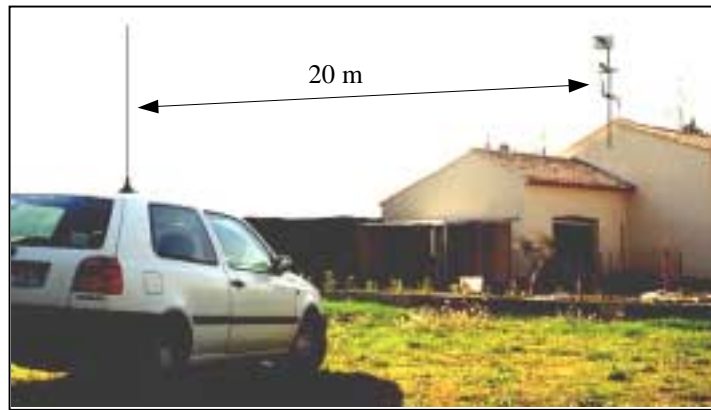

Figure 21: Test layout for complete TV installation tests in residence real site

6.2.2 Results

Table 16: 27 MHz RF level delivered by two complete TV installations (in dB μ V/75 Ω)

	TV installation 1	TV installation 2
TV bands	I – II – III – IV - V	III
27 MHz delivered level for a EM field of 125 dB μ V/m	117	111

6.3 Immunity synthesis of 20 complete TV installations

The three columns on the right, on Table 17, give the RF level at 27 MHz as it was measured at the antenna input of the TV. The crosses are the elements, previously tested and reported in previous clauses, used in each installation.

Table 17: TV set input level at 27 MHz in dB μ V/75 Ω by combining the elements tested

Cable	Antennas			Coupl.	Amplifiers			Extrapolated TV input level	Free field measures	Actual site measures
	UHF	VHF	FM		1	3	4			
X	X							108		
X	X				X			131		
X	X					X		10		
X	X						X	31		
X		X						115		
X		X			X			138		111
X		X				X		87		
X		X					X	83		
X			X					112		
X			X		X			135		
X	X	X		x				91		
X	X	X		X	X			114		
X	X	X				x		87	73	

Cable	Antennas			Coupl.	Amplifiers			Extrapolated TV input level	Free field measures	Actual site measures
	UHF	VHF	FM		1	3	4			
X	X	X					x	83	69	
X		X	X	X				111		
X		X	X	X	X			134		
X	X		X	X				111		
X	X		X	X	X			134		
X	X	X	X	X				111		
x	x	X	x	x	x			134	128	117

6.4 Comments

Shaded 27 MHz levels on Table 17 are those which exceed the limits of immunity for televisions, specified in EN 55020 [3], clause 9.2.

The measurements of the 27 MHz, collected in subclauses 6.1 and 6.2, allowed to establish by extrapolation the value of 134 dB μ V/75 Ω , when an installation with UHF/VHF/FM antennas + coupling + wide band amplifier 1, illuminated by a signal at 27 MHz of 125 dB μ V/m was used.

The measurements of such installation gave a collected value of 112 dB μ V/75 Ω on a free field site with a disturbance field of 109 dB μ V/75 Ω . By extrapolation the measurements gave a result of 128 dB μ V/75 Ω for a limit EM field of 125 dB μ V/m. The same measurements gave a level of 117 dB μ V/75 Ω on an actual site.

Likewise, by extrapolation, an installation provided with a VHF antenna + wide band amplifier 1 developed 138 dB μ V/75 Ω on the user terminal, whereas the measurement in actual site gave 111 dB μ V/75 Ω (see Table 17).

These differences are explained hereafter.

Free field measurements site:

The antenna factor was measured individually. In an installation, the distance separating the antennas is no more than 1 m. It is therefore very likely that a coupling would intervene and modify the value of the antenna factors.

Actual residence site:

The different result, as compared with the free field site, is explained by the fact that, in the true set up, the horizontal planes of the TV and FM antennas do not lie in the axis of the EM field. In fact, the antennas are at a height of approximately 10 m above the ground, whereas the CB transmitter antenna is located on a car roof (about 2 m). This means that the EM field illuminates the TV and FM antennas from below. The CB antenna factors obtained previously in clause 5 can not be taken in account.

7 Conclusions

The data contained in the present document enables some conclusions to be drawn as to the disturbance that will be experienced by a TV receiver installation when subjected to a 27 MHz EM field.

One significant element studied in the present document is the signal level received at 27 MHz on the wall antenna connector. To date the radiation level at 27 MHz at this point had not been quantified, that is taking into account the various elements making up the TV receiver installation measurements have only made at the antenna input of the TV receiver.

It is clearly not representative to consider just the TV receiver. The complete installation i.e. the elements outside the television set need also to be considered. It could be argued that the severity of such a test is insufficient to verify that the EMC requirements are complied with as the wanted environment includes the TV receiver installation and thus the whole needs to be considered as a system.

The results obtained from the installations described in the present document are identified in Table 17, which shows that with an EM field limit value of 125 dB μ V/m, the levels developed for the different TV set-ups exceed the limits set by Table 7 of EN 55020 [3]. In other words, the TV antenna installation itself supplies at its terminals a higher level than those identified in the above standard.

Furthermore, these levels can also be increased if an RF amplifier is included in the installation. The role of such amplifiers should be only to amplify the signal TV channels, whilst in fact, as there are no standards for such products, these RF devices frequently also amplify signals outside the broadcast bands including 27 MHz. Because of this lack of standards, some competent laboratories use EN 50083-2 [6] (for cable distribution systems) to check the behaviour of antenna amplifiers.

In conclusion, levels developed by significant number of TV installations exceed the limits of input immunity set by EN 55020 [3]. We believe that the EMC limits defined in EN 55020 [3] and EN 50083-2 [6] should be reviewed by CENELEC taking due account of the data contained in the present document.

History

Document history		
V1.1.1	August 2000	Publication