

## **Digital Video Broadcasting (DVB); Implementation guidelines for DVB terrestrial services; Transmission aspects**

---

European Broadcasting Union



Union Européenne de Radio-Télévision

**DVB**  
Digital Video  
Broadcasting



*European Telecommunications Standards Institute*

---

---

Reference

DTR/JTC-DVB-60 (b0o00ics.PDF)

---

Keywords

DVB, broadcasting, digital, video, MPEG, TV

***ETSI Secretariat***

---

Postal address

F-06921 Sophia Antipolis Cedex - FRANCE

---

Office address

650 Route des Lucioles - Sophia Antipolis  
Valbonne - FRANCE  
Tel.: +33 4 92 94 42 00 Fax: +33 4 93 65 47 16  
Siret N° 348 623 562 00017 - NAF 742 C  
Association à but non lucratif enregistrée à la  
Sous-Préfecture de Grasse (06) N° 7803/88

---

X.400

c= fr; a=atlas; p=etsi; s=secretariat

---

Internet

secretariat@etsi.fr  
<http://www.etsi.fr>

---

***Copyright Notification***

No part may be reproduced except as authorized by written permission.  
The copyright and the foregoing restriction extend to reproduction in all media.

© European Telecommunications Standards Institute 1997.  
© European Broadcasting Union 1997.  
All rights reserved.

# Contents

Intellectual Property Rights.....	6
Foreword .....	6
Introduction .....	7
1 Scope.....	9
2 References.....	9
3 Symbols and Abbreviations .....	10
3.1 Symbols .....	10
3.2 Abbreviations.....	11
4 DVB-T system – outline .....	12
4.1 Modes of operation.....	13
4.1.1 Choice of modulation scheme and inner coding.....	20
4.1.2 Choice of number of carriers.....	20
4.1.3 Choice between hierarchical and non-hierarchical mode .....	21
4.1.3.1 Non-hierarchical mode .....	22
4.1.3.2 Hierarchical mode.....	22
4.1.4 TPS explanation (use of TPS).....	24
4.2 Transmitter input signal .....	25
4.2.1 MPEG-2-TS multiplex signal.....	25
4.2.1.1 Services and bit-rates.....	25
4.2.1.2 Some technical background .....	26
4.2.2 Relation to DVB-C and DVB-S signals .....	26
4.3 Transmitter output signal .....	26
4.3.1 Power definition as RMS value .....	26
4.3.2 Spectrum mask to limit adjacent channel interference .....	27
4.3.3 Characterization of behaviour for planning by protection ratios .....	27
5 Basic aspects of DVB-T networks .....	27
5.1 MFN or conventionally planned networks.....	27
5.1.1 Principle of MFN .....	27
5.1.2 Frequency resources needed for MFN .....	28
5.1.3 Non-synchronous operation.....	28
5.1.4 Excess power.....	28
5.2 Single Frequency Networks (SFN) .....	28
5.2.1 Principle .....	28
5.2.2 Frequency efficiency .....	29
5.2.3 Power efficiency.....	29
5.2.4 Synchronous operation.....	29
5.3 MFN with local dense SFN around each MFN transmitter.....	29
5.4 Gap-filler.....	29
5.4.1 Professional gap fillers .....	30
5.4.2 Domestic gap fillers .....	30
6 Setting up DVB-T transmitters .....	31
6.1 RF issues, existing sites/sharing with analogue.....	31
6.1.1 Use of existing antenna .....	31
6.1.1.1 RF combining .....	32
6.1.1.2 Multi-channel amplification.....	32
6.1.2 New antenna dedicated to digital terrestrial TV.....	33
7 Setting up DVB-T distribution networks .....	34
7.1 Basic aspects of primary distribution.....	34
7.1.1 Centralized generation of the COFDM signal.....	34
7.1.2 Decentralized generation of the COFDM signal .....	34
7.1.2.1 Unequipped optical fibre ("Dark fibre").....	34

7.1.2.2	PDH networks.....	34
7.1.2.3	SDH networks.....	35
7.1.2.4	ATM networks.....	35
7.1.2.5	Satellite distribution.....	35
7.2	Synchronization .....	35
7.2.1	MPEG timing aspects.....	35
7.2.2	Synchronization of MPEG multiplexer and modulator .....	36
7.3	Network control and monitoring.....	36
8	SFN operation .....	36
8.1	Short recall on SFN exclusive features .....	36
8.2	Different implementation possibilities .....	37
8.2.1	Re-amplification of the signal at the RF level .....	37
8.2.2	Analogue distribution of the COFDM signal .....	37
8.2.3	Digital distribution of the MPEG stream.....	37
8.3	SFN constraints.....	37
8.3.1	Frequency synchronization.....	38
8.3.2	Time synchronization .....	38
8.3.3	Bit level synchronization.....	38
8.3.4	Energy dispersal synchronization.....	38
8.4	Network constraints .....	39
8.4.1	Cable/satellite/terrestrial commonalties.....	39
8.4.2	Maximum time spread in the network .....	39
8.4.3	Transit times stability .....	39
8.4.4	Possible candidates for absolute time reference .....	39
8.4.5	Remote control of distributed transmitters .....	39
8.5	The mega-frame solution .....	39
8.5.1	Why a mega-frame is necessary .....	39
8.5.2	The Mega-frame solution .....	40
8.5.3	Mega-frame definition.....	41
8.5.4	MIP format.....	42
8.5.5	A possible implementation .....	42
8.6	Hierarchical modes particularities. ....	42
8.6.1	Multiple channels network adapters .....	42
8.6.2	HP/LP time synchronization.....	43
9	Network planning.....	43
9.1	Coverage definitions for fixed and portable reception.....	43
9.1.1	Introduction.....	43
9.1.2	Fixed antenna reception .....	44
9.1.3	Portable antenna reception .....	44
9.1.4	Coverage area.....	44
9.1.5	Examples of practical usage .....	45
9.2	Minimum field strength considerations.....	45
9.2.1	Minimum receiver signal input levels .....	45
9.2.2	Signals levels for planning .....	46
9.2.2.1	General .....	46
9.2.2.2	Fixed antenna reception.....	48
9.2.2.2.1	Antenna directivity and gain .....	48
9.2.2.2.2	Minimum median power flux density and equivalent field strength.....	48
9.2.2.3	Portable antenna reception.....	52
9.2.2.3.1	General.....	52
9.2.2.3.2	Criteria for portable reception of digital TV .....	53
9.2.2.3.3	Minimum median power flux density and equivalent field strength.....	57
9.3	Aspects of sharing with existing services.....	65
9.3.1	Protection ratios .....	66
9.3.1.1	DVB-T interfered with by DVB-T .....	66
9.3.1.2	DVB-T interfered with by analogue television.....	67
9.3.1.2.1	Co-channel protection ratios .....	67
9.3.1.2.2	Lower adjacent channel (n - 1).....	68
9.3.1.2.3	Upper adjacent channel (n + 1).....	68

9.3.1.2.4	Image channel .....	68
9.3.1.2.5	Overlapping channels.....	68
9.3.1.3	Analogue TV interfered with by DVB-T.....	69
9.3.1.3.1	Co-channel protection ratios .....	69
9.3.1.3.2	Lower adjacent channel (n - 1).....	69
9.3.1.3.3	Upper adjacent channel (n + 1).....	70
9.3.1.3.4	Image channel .....	70
9.3.1.3.5	Overlapping channels.....	70
9.3.1.4	Sound signals associated with analogue television, interfered with by DVB-T.....	72
9.3.1.5	DVB-T interfered with by T-DAB .....	73
9.3.1.6	T-DAB interfered with by DVB-T .....	73
9.3.2	Procedures for the protection of analogue TV services.....	73
9.3.2.1	Establishment of the size of analogue TV coverage areas .....	74
9.3.2.2	Protection on national boundaries .....	76
9.3.3	Protection of other services.....	76
9.3.4	Protection of previously co-ordinated digital TV services .....	76
History .....		77

---

## Intellectual Property Rights

IPRs essential or potentially essential to the present document may have been declared to ETSI. The information pertaining to these essential IPRs, if any, is publicly available for **ETSI members and non-members** and can be found in ETR 314: "*Intellectual Property Rights (IPRs); Essential, or potentially Essential, IPRs notified to ETSI in respect of ETSI standards*", which is available **free of charge** from the ETSI Secretariat. Latest updates are available on the ETSI Web server (<http://www.etsi.fr/ipr>).

Pursuant to the ETSI Interim IPR Policy, no investigation, including IPR searches, has been carried out by ETSI. No guarantee can be given as to the existence of other IPRs not referenced in ETR 314 (or the updates on <http://www.etsi.fr/ipr>) which are, or may be, or may become, essential to the present document.

---

## Foreword

This Technical Report (TR) has been produced by the DVB Project and submitted for publication to the Joint Technical Committee (JTC) of the European Broadcasting Union (EBU), Comité Européen de Normalization ELECTrotechnique (CENELEC) and the European Telecommunications Standards Institute (ETSI).

NOTE: The EBU/ETSI JTC was established in 1990 to co-ordinate the drafting of standards in the specific field of broadcasting and related fields. Since 1995 the JTC became a tripartite body by including in the Memorandum of Understanding also CENELEC, which is responsible for the standardization of radio and television receivers. The EBU is a professional association of broadcasting organizations whose work includes the co-ordination of its members' activities in the technical, legal, programme-making and programme-exchange domains. The EBU has active members in about 60 countries in the European broadcasting area; its headquarters is in Geneva\*.

\* European Broadcasting Union

CH-1218 GRAND SACONNEX (Geneva)

Switzerland

Tel: +41 22 717 21 11

Fax: +41 22 717 24 81

### Digital Video Broadcasting (DVB) Project

Founded in September 1993, the DVB Project is a market-led consortium of public and private sector organizations in the television industry. Its aim is to establish the framework for the introduction of MPEG-2 based digital TV services. Now comprising over 200 organizations from more than 25 countries around the world, DVB fosters market-led systems, which meet the real needs and economic circumstances, of the consumer electronics and the broadcast industry.

---

# Introduction

The present document gives the first guidelines for implementation of Digital Video Broadcasting Terrestrial (DVB-T) transmitting networks.

Its primary intention is to be a guide to the transmission aspects, while receiver aspects have not been dealt with.

The present document describes the main features of the DVB Terrestrial (DVB-T) system and gives guidelines for setting up of DVB-T transmitting networks. This includes a general description of network topologies for Single Frequency Networks (SFN) and Multi-Frequency Networks (MFN), the possibilities and constraints when sharing transmitting sites with analogue TV and a summary of planning parameters.

A basic introduction to distribution of MPEG-2 Transport Streams (TS) to DVB-T transmitters, including the timing aspects, is also included.

Distribution of signals to SFNs is dealt with in order to give guidelines for the particular constraints this network structure implies to the distribution of signals.

Updates to the present document will be produced when more results from DVB-T compliant hardware tests and experience from field trials become available.

## Objective

- The present document describes the Digital Video Broadcasting Terrestrial (DVB-T (see EN 300 744 [5]) specification for digital terrestrial TV broadcasting. It tries to draw attention to the technical questions that need to be answered in setting up a DVB-T network and offers some guidance in finding answers to them. It does not cover issues linked to the content of the broadcasts such as Service Information (SI), Electronic Programme Guides (EPG) and Access Control (CA).
- Guidelines for implementation of MPEG-2 and Service Information (SI) can be found in ETR 154 [1] and ETR 211 [2].

## Target readers

- This document is aimed at the Technical Departments of broadcasting organizations that are considering implementing digital terrestrial TV. It assumes that readers are familiar with analogue broadcasting networks but have only a general knowledge of digital broadcasting techniques.

## Contributors

- This document was initially prepared by members of Module 1 of ACTS project VALIDATE including broadcasters and the EBU, network operators and professional and domestic equipment manufacturers.

## Outline of the present document

- **DVB-T system - outline (see clause 4)**

This clause describes the DVB-T (see EN 300 744 [5]) specification and the choice of modes of operation the broadcaster has to make in implementing it. The reason for the range of choices is the different applications foreseen and the different introduction scenarios expected in different countries. The parameters that can be chosen for a given application are:

- a) Fast Fourier Transform (FFT) length, which specifies the number of carriers (2k $\Rightarrow$ 1 705 carriers; 8k $\Rightarrow$ 6 817 carriers)
- b) carrier modulation (QPSK $\Rightarrow$  2 bit per carrier; 16-QAM $\Rightarrow$  4 bit; 64-QAM $\Rightarrow$  6 bit)
- c) code rate of inner error protection (1/2; 2/3; 3/4; 5/6; 7/8)
- d) guard interval length (1/4; 1/8; 1/16; 1/32)
- e) non-hierarchical or hierarchical modulation and modulation parameter  $\alpha$

The choice of mode will set the data capacity of the system and will affect the coverage of different kinds of receiving installation - fixed roof-top antennas or portable receivers. The different modes are described and the factors affecting the choice of mode are explained.

The transmitter input signal is specified as an MPEG-2-TS, which may contain several TV programmes and possibly some sound/data only programmes. The Guide gives some advice on the bit-rates needed for different services and explains some of the terms relevant to MPEG-2 multiplexing. It also explains how the DVB-T (see EN 300 744 [5]) specification is related to the DVB Cable (DVB-C) (see EN 300 429 [4]) and DVB Satellite (DVB-S) (see EN 300 421 [3]) specifications for cable and satellite broadcasting.

Finally, the transmitter output signal is described in a qualitative way, explaining how its properties affect the interference it can cause to other services.

#### **Basic aspects of DVB-T networks (see clause 5)**

DVB-T networks can be planned in the same way as analogue networks, using an individual set of radio frequencies for each transmission site. This approach is referred to as a MFN and is often considered when an administration wishes to re-use some or all of the spectrum used for analogue broadcasting.

Because delayed signals arriving within the guard interval can be beneficial to a Coded Orthogonal Frequency Division Multiplex (COFDM) receiver, rather than interfering as with analogue signals, it is possible, if a suitable frequency is available and a sufficiently long guard interval is chosen, for all transmitters in a region, or in a country, to use the same frequency in a Single Frequency Network. SFN techniques can be used on a smaller scale to fill gaps in coverage, or even within a house where a domestic gap-filler could give portable reception.

#### **Setting up DVB-T transmitters (see clause 6)**

The digital TV transmitters will, in general, re-use the same sites as existing analogue TV transmitters, so that a large part of the existing analogue infrastructure may be re-used. In some cases a new antenna will be needed; if the existing antenna is to be used, then the digital signals have to be combined at high power with existing analogue signals or a multi-channel amplifier is needed. Different problems of filtering and non-linearity arise in each of these cases.

#### **Setting up DVB-T distribution networks (see clause 7)**

The COFDM signal can be modulated at a central point and distributed to transmitters via analogue links. But in general a digital primary distribution network will be needed to distribute MPEG-2-TS from TV studio centres to remultiplexing sites if the network has regional variations and to transmitters; possible choices are optical fibre, PDH or SDH networks, Asynchronous Transfer Mode (ATM) and satellite distribution. The timing of the primary distribution has to be controlled to ensure that it does not induce jitter in MPEG-2 decoders and to ensure stable synchronization of the MPEG-2 multiplexers and the COFDM modulators. Each piece of equipment in the programme chain will have a control input to change modes, bit-rates etc. All sites will therefore need to be linked by a control and monitoring network.

#### **SFN operation (see clause 8)**

All transmitters in an SFN has to be synchronized so that their emitted signals are frequency identical and bit identical. SFN operation therefore requires special equipment in the primary distribution network to ensure this synchronization using a universal time and frequency reference such as that available from the Global Positioning System (GPS) satellite system.

#### **Network planning (see clause 9)**

Digital TV service coverage is characterized by a very rapid transition from near perfect reception to no reception at all and it thus becomes much more critical to be able to define which areas are going to be covered and which are not. This clause gives definitions of service planning terms as used for digital TV, gives details of the field strengths needed in different bands for different reception conditions and considers the protection ratios used to allow for the effects of interference when digital services share the UHF band with analogue services.



---

# 1 Scope

The present document describes the Digital Video Broadcasting Terrestrial (DVB-T) specification for digital terrestrial TV broadcasting. It tries to draw attention to the technical questions that need to be answered in setting up a DVB-T network and offers some guidance in finding answers to them. It does not cover issues linked to the content of the broadcasts such as Service Information (SI), Electronic Programme Guides (EPG) and Access Control (CA).

Guidelines for implementation of MPEG-2 and Service Information (SI) can be found in ETR 154 [1] and ETR 211 [2].

---

# 2 References

References may be made to:

- a) specific versions of publications (identified by date of publication, edition number, version number, etc.), in which case, subsequent revisions to the referenced document do not apply; or
- b) all versions up to and including the identified version (identified by "up to and including" before the version identity); or
- c) all versions subsequent to and including the identified version (identified by "onwards" following the version identity); or
- d) publications without mention of a specific version, in which case the latest version applies.

A non-specific reference to an ETS shall also be taken to refer to later versions published as an EN with the same number.

- [1] ETR 154: "Digital Video Broadcasting (DVB); Implementation guidelines for the use of MPEG-2 Systems, Video and Audio in satellite, cable and terrestrial broadcasting applications".
- [2] ETR 211: "Digital Video Broadcasting (DVB); Guidelines on implementation and usage of Service Information (SI)".
- [3] EN 300 421: "Digital Video Broadcasting (DVB); DVB framing structure, channel coding and modulation for 11/12 GHz satellite services". Known as (DVB-S).
- [4] EN 300 429: "Digital Video Broadcasting (DVB); DVB framing structure, channel coding and modulation for cable systems". Known as (DVB-C).
- [5] EN 300 744: "Digital Video Broadcasting (DVB); Framing structure, channel coding and modulation for digital terrestrial television". Known as "DVB-T".
- [6] ETS 300 813: "Digital Video Broadcasting (DVB); Interfaces to Plesiochronous Digital Hierarchy (PDH) networks".
- [7] ETS 300 814: "Digital Video Broadcasting (DVB); Interfaces to Synchronous Digital Hierarchy (SDH) networks".
- [8] EN 50083-9 CENELEC: "Cabled Distribution Systems for Television, Sound and Interactive Multimedia Signals; Part 9: Interfaces for CATV/SMATV Headends and similar Professional Equipment".
- [9] ISO/IEC 13818-1: "Information Technology - Generic Coding of Moving Pictures and Associated Audio Information. Part 1: Systems".
- [10] ITU-R Draft New Recommendation BT (XXD/XXI): "Error-correction, data framing, modulation and emission methods for digital terrestrial television broadcasting".
- [11] ITU-R Recommendation 405: "Pre-emphasis characteristics for frequency modulation radio-relay systems for television (up to 1990)".

- [12] ITU-T Recommendation G703: "Physical/electrical characteristics of hierarchical digital interfaces".
- [13] TS 101 191: "Digital video broadcasting(DVB); Specification of a mega-frame for SFN synchronization".
- [14] EBU BPN 005: "Terrestrial digital television planning and implementation considerations. Second issue, July 1997".
- [15] CEPT: "The Chester 1997 Multilateral Coordination Agreement relating to Technical Criteria, Coordination Principles and Procedures for the introduction of Terrestrial Digital Video Broadcasting (DVB-T)".
- [16] ITU-R Recommendation BT.419: "Directivity and polarization discrimination of antennas in the reception of television broadcasting".
- [17] ITU-R Recommendation P.370: "VHF and UHF propagation curves for the frequency range 30 MHz to 1 000 MHz".
- [18] ITU-R Report 1203: "Digital sound broadcasting to vehicular, portable and fixed receivers using terrestrial transmitters in the UHF/VHF bands".
- [19] ITU-R Draft New Recommendation BT (XYZ): "Criteria required for planning of digital terrestrial television services in the VHF/UHF television bands".

---

## 3 Symbols and Abbreviations

### 3.1 Symbols

For the purposes of the present document, the following symbols (shown in order of appearance) apply:

$\alpha$	Constellation ratio for hierarchical modulation
$R_U$	Useful bitrate
$R_S$	Symbol rate
$b$	number of bits per carrier
$CR_I$	Inner code rate
$CR_{RS}$	Reed-Solomon code rate (188/204)
$T_U$	Time duration of the useful (orthogonal) part of a symbol, without the guard interval
$T_S$	Time duration of an OFDM symbol
$\Delta f$	OFDM carrier spacing
$f_k$	RF position of the $k^{\text{th}}$ carrier
$\Delta T$	Guard interval duration
$M$	Megaframe index
$B$	Receiver noise bandwidth
$F$	Receiver noise figure
$P_n$	Receiver noise input power
$P_{S \text{ min}}$	Minimum receiver signal input power
$Z_i$	Receiver input impedance
$U_{S \text{ min}}$	Minimum equivalent receiver input voltage into $Z_i$
$k$	Boltzman's constant
$T_0$	Absolute temperature
$\phi_{\text{min}}$	Minimum power flux density at receiving place (dBW/m <sup>2</sup> )
$E_{\text{min}}$	Equivalent minimum field strength at receiving place (dB $\mu$ V/m)
$L_f$	Feeder loss (dB)
$L_h$	Height loss (10 m a.g.l. to 1,5 m. a.g.l.) (dB)
$L_b$	Building penetration loss (dB)
$P_{\text{mmn}}$	Allowance for man made noise (dB)
$C_1$	Location correction factor (dB)
$\phi_{\text{med}}$	Minimum median power flux density, planning value (dBW/m <sup>2</sup> )

$E_{\text{med}}$	Minimum median equivalent field strength, planning value (dB $\mu$ V/m)
$F_A$	Actual frequency being considered
$F_R$	Reference frequency
PR	Protection ratio
PR(CCI)	Co-channel protection ratio
BO	Bandwidth (in MHz) in which the two DVB-T signals are overlapping
BW	Bandwidth (in MHz) of the wanted signal
$\Delta F$	Frequency difference

## 3.2 Abbreviations

For the purposes of the present document, the following abbreviations apply:

a.g.l.	above ground level
AAL	ATM Adaptation Layers
ACI	Adjacent-Channel Interference
ACTS	Advanced Communications Technologies and Services (Research programme supported by the European Commission)
API	Application Programming Interface
ATM	Asynchronous Transfer Mode
BBC	British Broadcasting Corporation (UK)
BER	Bit Error Ratio
BPN	EBU numbering system for documents
C/N	Carrier to Noise ratio
CA	Access Control
CATV	Community Antenna TeleVision
CCI	Co-Channel Interference
COFDM	Coded Orthogonal Frequency Division Multiplex
DAB	Digital Audio Broadcasting
DC	Direct Current
DCF77	High precision standard frequency transmitter (77,5 MHz) in Germany
dTTb	digital Terrestrial Television broadcasting
DVB	Digital Video Broadcasting
DVB-C	DVB Cable
DVBIRD	DVB Integrated Receiver Decoder (ACTS project AC 108)
DVB-PI	DVB Professional Interface
DVB-S	DVB Satellite
DVB-T	DVB Terrestrial
EBU	European Broadcasting Union
END	Equivalent Noise Degradation
EPG	Electronic Programme Guides
ERP	Effective Radiated Power
FFT	Fast Fourier Transform
FM	Frequency Modulation
GPS	Global Positioning System
HDTV	High Definition TeleVision
HP	High Priority
IDFT	Inverse Discrete Fourier Transform
IF	Intermediate Frequency
IFFT	Inverse Fast Fourier Transform
LP	Low Priority
MFN	Multi-Frequency Network
MIP	Mega-frame Initialization Packet
MPEG	Moving Picture Experts Group
MSF	High precision standard frequency transmitter (60 kHz) in England
MUX	Multiplex
NICAM	Near-Instantaneous Companded Audio Multiplex
OFDM	Orthogonal Frequency Division Multiplex
PAL	Phase Alternation Line (Colour TV-System)

PCR	Programme Clock Reference
PDH	Plesiochronous Digital Hierarchy
PES	Packetized Elementary Stream
PID	Packet Identifier
PR	Protection Ratios
PRBS	Pseudo-Random Bit Sequence
PTS	Presentation Time-Stamp
QAM	Quadrature Amplitude Modulation
QPSK	Quadrature Phase Shift Keying (4-PSK)
RACE	R & D in Advanced Communications-Technologies (Research programme supported by the European Commission)
RCPC	Rate Compatible Punctured Convolutional
RF	Radio Frequency
RMS	Root Mean Square (value)
SAS	Subscriber Authorization System
SAW	Surface Acoustic Wave
SDH	Synchronous Digital Hierarchy
SECAM	Sequentielle Couleur Avec Memoire (French Colour-TV System)
SFDMA	Synchronous Frequency Division Multiple Access
SFN	Single Frequency Network
SHF	Super High Frequency (3 GHz to 30 GHz)
SI	Service Information
STM	Synchronous Transport Module
STS	Synchronization Time Stamp
TPS	Transmission Signalling Parameters
TS	Transport Stream
TV	TeleVision
UHF	Ultra-High Frequency (300 MHz to 3 000 MHz)
Validate	Verification and Launch of Integrated Digital Advanced Television in Europe (ACTS project AC106)
VHF	Very High Frequency (30 MHz to 300 MHz)

---

## 4 DVB-T system – outline

The DVB-T system addresses the terrestrial broadcasting of MPEG-2 coded TV signals. Therefore an appropriate adaptation of the digital coded transport stream to the different terrestrial channel characteristics is necessary. These requirements result in a flexible transmission system that uses a multi-carrier modulation, the so called Orthogonal Frequency Division Multiplex (OFDM) technique, combined with a powerful concatenated error correction coding (Coded Orthogonal Frequency Division Multiplex, COFDM). The aim of the following subclauses is to give a general idea of the parameters of the DVB-T system.

To achieve a maximum spectrum efficiency when used within the UHF bands, the OFDM technique with two options in the number of carriers, three modulation schemes and different guard intervals allows the operation of small and large Single Frequency Networks (SFN). In a specified range, the reception of identical programmes from a number of transmitters on the same frequency is beneficial.

As far as bandwidth requirements are concerned the preferred channel spacing is 8 MHz, but if desired, 7 MHz or 6 MHz spacing is also possible by scaling down all system parameters (Reference: ITU-R Draft new Recommendation .XXD/XXI).

The concatenated error correction can be separated in two blocks: the outer coding and outer interleaving are common to the Satellite and Cable Baseline Specifications and the inner coding is common to Satellite Baseline specification. The use of inner interleaving is specific to the DVB-T system.

To accommodate different transmission rates, in addition to five code rates, three types of non-differential modulation schemes can be selected: QPSK, 16-QAM and 64-QAM. The 16-QAM and 64-QAM can also be used in combination with uniform or non-uniform mapping rules and thus input data streams can be separated in a low and a high priority data stream with different error protection for hierarchical transmission purposes. This feature allows the simulcast broadcasting of different programmes with different error protection and coverage areas. For reasons of receiver economy hierarchical transmission, is supported by the DVB-T system whilst hierarchical coding is not.

The characteristics of this very highly flexible transmission system are described in more detail within the following clauses.

## 4.1 Modes of operation

To avoid disturbances by interference from echoes or from the signals from adjacent transmitters in SFNs, a **guard interval** is inserted between consecutive OFDM symbols. The guard interval precedes every OFDM symbol. Echoes of the previous symbol should abate within the guard interval. Otherwise the echoes would disturb the following OFDM symbol and increase the Bit Error Ratio (BER). Therefore, the required length of the guard interval depends on the application to be covered.

Considering an SFN, the distance between two adjacent transmitter stations determines the necessary length of the guard interval. Simulations have shown that a guard interval of at least 200  $\mu\text{s}$  is necessary for large area SFN.

A longer guard interval could compensate longer echoes:

- lengthening the guard interval without changing the absolute duration of the useful interval would accordingly decrease the channel capacity, thus reducing the deliverable bitrate;
- alternatively, lengthening both the guard interval and the useful interval would not bring any penalty to the channel capacity, but would make the signal processing more difficult because of the higher number of carriers that would result from the larger symbol duration.

Table 1 summarizes the possible lengths of the guard interval specified in the DVB-T (see EN 300 744 [5]) specification depending on the chosen FFT length.

**Table 1: Specified lengths of the guard interval**

proportion to the length of the useful interval	Length of the guard interval	
	8k-mode	2k-mode
1/4	224 $\mu\text{s}$	56 $\mu\text{s}$
1/8	112 $\mu\text{s}$	28 $\mu\text{s}$
1/16	56 $\mu\text{s}$	14 $\mu\text{s}$
1/32	28 $\mu\text{s}$	7 $\mu\text{s}$

The longer guard intervals are suitable for networks with longer distances between the particular transmitter station, as for example with national single frequency networks. The shorter intervals are suitable for regional or local broadcast transmissions.

According to table 1, there are two different modes regarding to the **number of carriers**. The length of the useful interval is 896  $\mu\text{s}$  for the 8k-mode and 224  $\mu\text{s}$  for the 2k-mode. Due to the orthogonality of the system, this corresponds to a carrier distance of 1 116 Hz and 4 464 Hz, respectively.

One basic requirement for the DVB-T system was the bandwidth constraint in order to match an 8 MHz channel spacing. From this requirement one can derive the number of possible carriers. 6 817 carriers per OFDM symbol for the 8k-mode (6 048 useful, the others for synchronization and signalling) and 1 705 carriers per OFDM symbol for the 2k-mode (1 512 useful carriers) are specified in the DVB-T system. The OFDM symbols can be calculated by the Inverse Discrete Fourier Transform (IDFT). Virtual carriers are inserted in such a way that the total number of carriers becomes a power of two, so that the faster algorithm of the Inverse Fast Fourier Transform (IFFT) can be used. At the receiving side, the corresponding signals can be easily recovered using the respective 2k-FFT or 8k-FFT.

In order to ensure robust transmission of the OFDM signal, an error protection code is applied. In addition to the fixed algorithm of energy dispersal, block coding, outer and inner interleaving, a Rate Compatible Punctured Convolutional (RCPC) code has been defined as in the DVB Satellite standard. The mother code has a constraint length of 7 bits and works with a code rate of 1/2. The two generator polynomials of the convolutional encoder are 171 and 133 in octal notation.

To adapt the error protection to the actual transmitting conditions, several **code rates** can be chosen. The following code rates are specified in the DVB-T (see EN 300 744 [5]) (and DVB Satellite (DVB-S) (see EN 300 421 [3])) system:

1/2, 2/3, 3/4, 5/6, 7/8

The code rate 1/2 has the highest redundancy, but the highest transmission safety. This mode should be applied to strongly disturbed channels. On the other hand a code rate of 7/8 has a low redundancy but a very weak error protection. Therefore, it should be used for channels with only low interference.

As mentioned above, every carrier is modulated by a modulation symbol. QPSK, 16-QAM and 64-QAM are used as modulation methods, e.g. 2, 4 or 6 bits per modulation symbol. The bits are assigned to the particular points in the phase space according to the so called Gray-code mapping. The advantage of this mapping is the fact that closest constellation points differ only in one bit. The constellation diagrams for each modulation method are illustrated in figure 1.

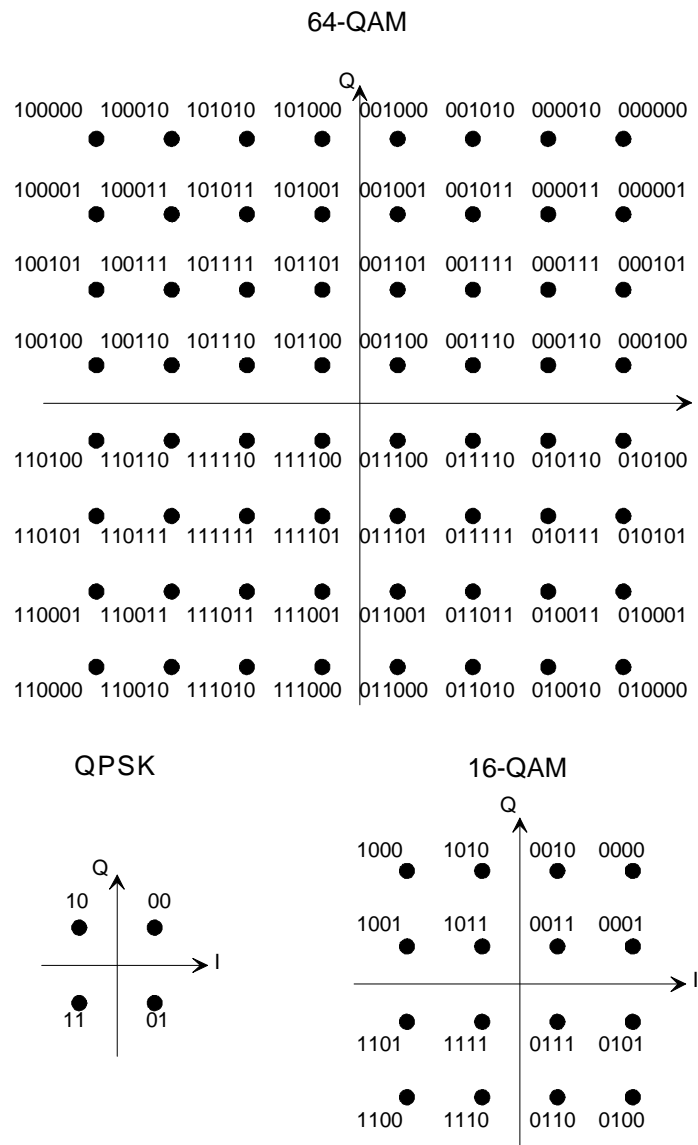

**Figure 1: Constellation diagram for the modulation methods specified for DVB-T**

A further feature defined in the DVB-T (see EN 300 744 [5]) specification is *hierarchical modulation*. While the audio and video quality of the analogue TV decreases gradually, digital transmission techniques preserve their reception quality up to a certain point but then suddenly show total signal disruption, as the transmission conditions become progressively poorer.

To overcome this problem, the data to be transmitted can be split into two parts. The first part provides the basic TV service with a relatively low data rate and a high error protection. The second part could be used for additional services with higher data rates and weaker error protection. In general, there are two possibilities for using this second data part.

On the one hand, additional programmes can be transmitted, on the other the higher data rate can be used to increase the quality of the basic service.

The level of error protection can be adjusted by choosing different code rates of the inner convolutional encoder. Both data streams are modulated simultaneously. Each carrier is modulated by two data symbols with different error protection. The symbol with the higher protection is modulated using the more resilient modulation method. It carries the information about the quadrant of the constellation point in the phase space. The other symbol gives the information about the location of that constellation point within each quadrant.

The need to completely separate signal processing of each data stream is a disadvantage of the method described above. Figure 2 illustrates the constellation diagrams for the hierarchical 16-QAM and 64-QAM.

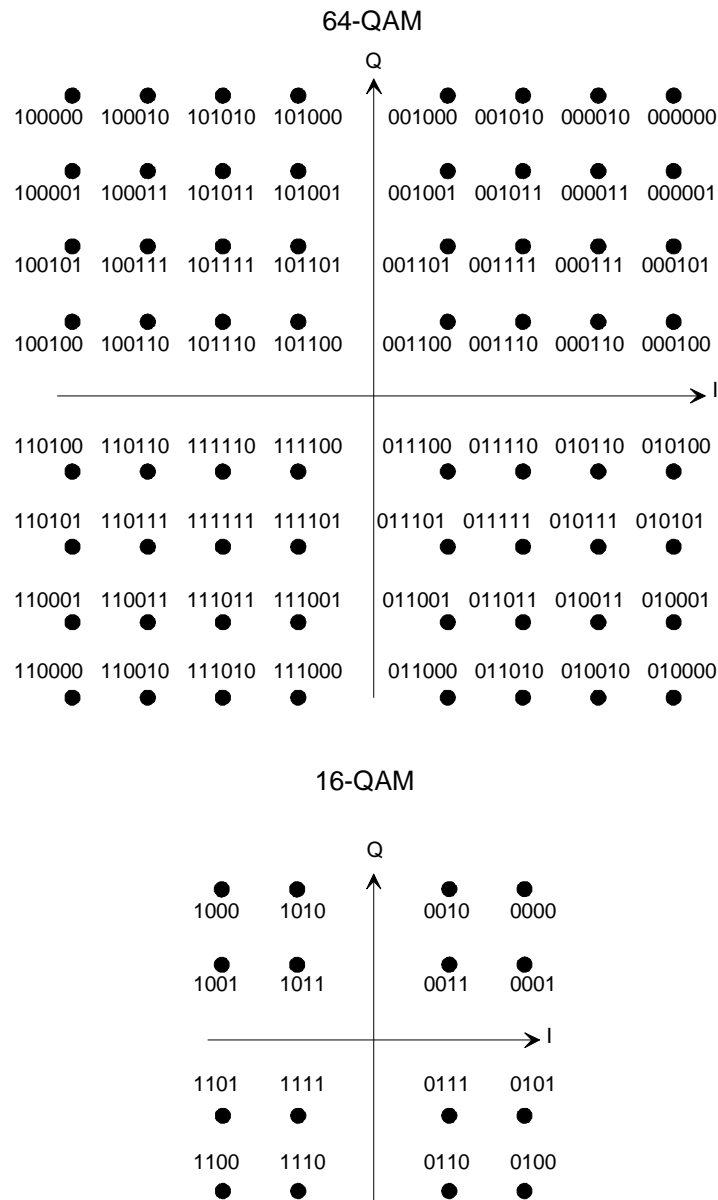

**Figure 2: Constellation diagram for the hierarchical modulation ( $\alpha=2$ )**

The distance between the constellation points is determined by the modulation parameter  $\alpha$ . Here, the parameter  $\alpha$  is defined as the relation of the distance between two neighbouring constellation points of two quadrants and the distance between two neighbouring constellation points within one quadrant. In the DVB-T specification (see EN 300 744 [5]), three values for this parameter are defined:  $\alpha = 1$  (uniform modulation);  $\alpha = 2$  and  $\alpha = 4$ .

In summary, the following parameters can be chosen in the DVB-T system:

- code rate of inner error protection(1/2; 2/3; 3/4; 5/6; 7/8);
- carrier modulation (QPSK⇒ 2 bit per carrier; 16-QAM⇒ 4 bit; 64-QAM⇒ 6 bit);
- guard interval length (1/4; 1/8; 1/16; 1/32);
- modulation parameter  $\alpha$  (1⇒non-hierarchical; 2, 4⇒hierarchical);
- FFT length; number of carriers (2k⇒1 705 carriers; 8k⇒6 817 carriers).

As noted above the net deliverable data rate depends on the code. Redundancy is added by the inner coding (dependent on the code rate) and by the outer code (204 instead of 188 bytes). The net bit rate depends on the code rate of the inner error correction, the method of the carrier modulation and the chosen guard interval length. Table 2 and figure 3 summarize all possible net data rates in the DVB-T system. The net data rates are calculated from the following formula:

$$R_U = R_S \times b \times CR_I \times CR_{RS} \times (T_U/T_S);$$

where:

$R_U$ : the useful net data rate (Mbit/s);

$R_S$ : the symbol rate, 6,75 Msymbols/s;

$b$ : bits per carrier;

$CR_I$ : inner code rate;

$CR_{RS}$ : Reed Solomon code rate, 188/204;

$T_U$ : duration of (useful) symbol part;

$T_S$ : symbol duration, including guard interval;

$T_U/T_S$ : 4/5, 8/9, 16/17, or 32/33 depending on guard interval.

**Table 2: Net data rates in the DVB-T system (in Mbit/s)**

Modulation	Bits per sub-carrier	Inner code rate	Guard interval			
			1/4	1/8	1/16	1/32
QPSK	2	1/2	4,98	5,53	5,85	6,03
	2	2/3	6,64	7,37	7,81	8,04
	2	3/4	7,46	8,29	8,78	9,05
	2	5/6	8,29	9,22	9,76	10,05
	2	7/8	8,71	9,68	10,25	10,56
16-QAM	4	1/2	9,95	11,06	11,71	12,06
	4	2/3	13,27	14,75	15,61	16,09
	4	3/4	14,93	16,59	17,56	18,10
	4	5/6	16,59	18,43	19,52	20,11
	4	7/8	17,42	19,35	20,49	21,11
64-QAM	6	1/2	14,93	16,59	17,56	18,10
	6	2/3	19,91	22,12	23,42	24,13
	6	3/4	22,39	24,88	26,35	27,14
	6	5/6	24,88	27,65	29,27	30,16
	6	7/8	26,13	29,03	30,74	31,67



DVB-T net data rates

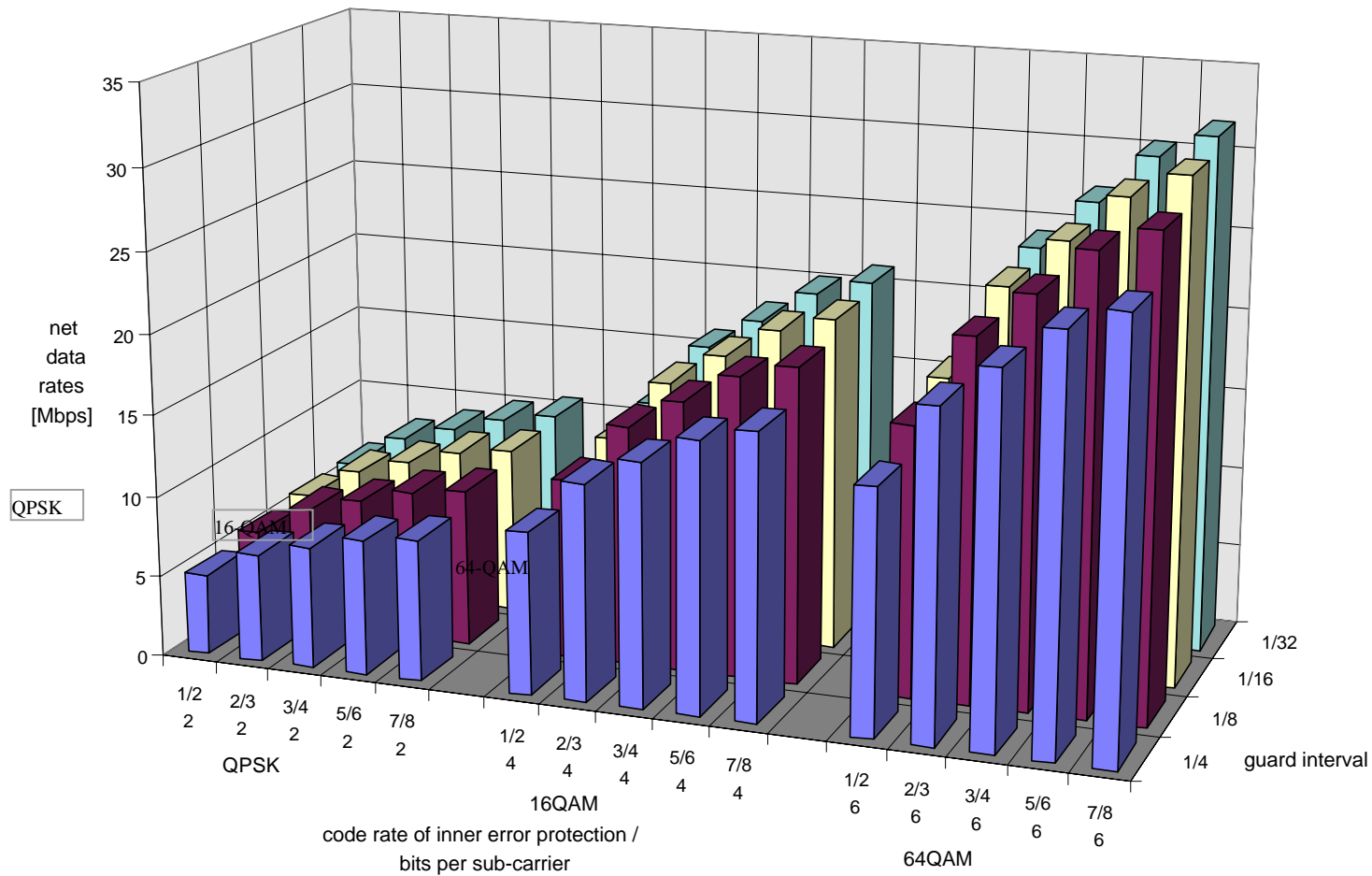

Figure 3: Net data rates in the DVB-T system

Considering the diagram in figure 4, the net bit-rates increase with higher code rates of the inner error protection, shorter guard intervals and higher stages of carrier modulation. That means a higher data rate can only be achieved by decreasing the amount of the error protection. Therefore, the lowest specified data rate (4,98 Mbit/s) corresponds to the best protected transmission (guard interval = 1/4; inner code rate = 1/2; QPSK modulation). This is illustrated by the column in the left front corner of the diagram in figure 3. At the other extreme, the column in the right back corner corresponds to a data transmission with the highest specified data rate (31,67 Mbit/s), but with the weakest error protection (guard interval = 1/32; inner code rate = 7/8; 64-QAM modulation). In practice, it is necessary to find a compromise between the deliverable data rate and the error protection for every application.

Figure 4 shows another overview of all DVB-T modes, that gives both Carrier to Noise ratio (C/N) and net bit-rate values, as a function of the constellation, code rate, guard interval length and the different channel profiles referred to in the DVB-T specification (see EN 300 744 [5]).

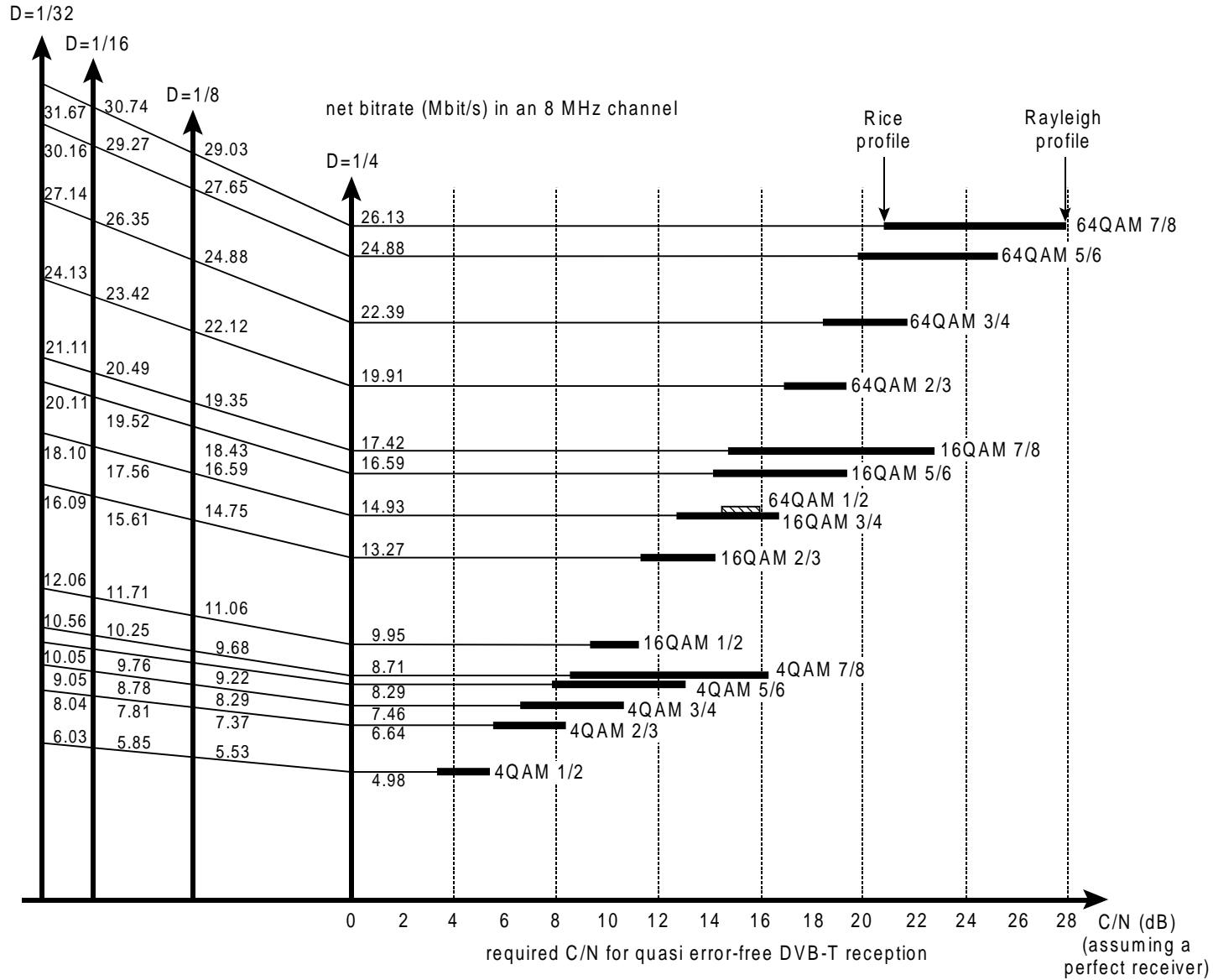

Figure 4: C/N and net bit-rate as a function of the constellation, code rate, guard interval length and channel profile for all DVB-T modes

### 4.1.1 Choice of modulation scheme and inner coding

As described above, three different modulation schemes (signal constellations) are available in the DVB-T (see EN 300 744 [5]) specification: QPSK, 16-QAM and 64-QAM. Any of these signal constellations can be combined with any of five different code rates: 1/2, 2/3, 3/4, 5/6, 7/8. The performance of a specific transmission mode depends on the combined effect of code rate and modulation scheme; from a performance point of view it is not therefore possible to treat the choice of signal constellation separately from the choice of inner code rate.

Compared with QPSK modulation and for a given code rate, the data capacity for 16-QAM is doubled and for 64-QAM tripled. The corresponding required C/N values required for good reception are approximately 6 dB and 12 dB higher respectively.

Similarly, both the data capacity available and the required C/N increase with higher code rates. Simulations of a Ricean channel (typical of good reception with a roof top antenna) show that the code rate of 7/8 requires approximately 6 dB higher C/N compared with a code rate of 1/2, for a given signal constellation, while the data capacity increases by a factor of 7/4. These values of required C/N are based on simulations and it is expected that the difference in a practical consumer receiver will be larger, due to a greater implementation loss for rate 7/8 compared with code rate 1/2. This is especially true when the signal constellation is 64-QAM.

The C/N required at a receiver has a direct consequence on the required Effective Radiated Power (ERP) of a transmitter, which has to be increased correspondingly, for a given coverage in many cases however the maximum transmitted ERP will be restricted due to potential interference to existing analogue TV services.

The choice of modulation scheme and code rate depends on the nature of the impairments expected in the channel. Figure 4 shows that the difference between the required C/N for roof-top reception (Rice profile) and for reception on an indoor portable (Rayleigh profile) is quite small for a code rate of 1/2, but for a code rate of 7/8 the difference in C/N is of the order of 8 dB. This is because the coding used in the DVB-T (see EN 300 744 [5]) specification is particularly robust in an OFDM system against frequency-selective interference that does not change greatly from one OFDM symbol to the next, such as stationary delayed signals or interference from analogue TV transmissions. So if such echoes or interference are expected to be the main limitation on reception, then a lower code rate will offer significantly better performance.

A comparison between the two modes 64-QAM R=1/2 and 16-QAM R=3/4 illustrates the impact of code rate. The two modes provide the same bit rate (14,93 to 18,1 Mbit/s, depending on guard interval), but the performance depends on the channel: according to simulations, in Gaussian and Ricean channels (corresponding to stationary roof-top reception) the 16-QAM R=3/4 mode is the better whereas in a highly selective channel, such as a Rayleigh channel (corresponding to portable reception), 64-QAM R=1/2 is the preferred choice. The choice of signal constellation therefore always has to be made in conjunction with code rate and the nature of channel impairments.

Reception on portable receivers is one obvious case where echoes and interference are expected to be the main limitation on reception. But even for reception with rooftop antennas the coverage area for those DVB-T transmitters that share frequency bands with analogue TV networks can be limited by interference from analogue TV transmitters. And where SFN techniques are used, delayed signals from adjacent transmitters will be common. Since robustness against interference from analogue TV signals and from delayed signals is more strongly related to the code rate than to the constellation, it will generally be better to choose a mode with a lower code rate.

### 4.1.2 Choice of number of carriers

The length of the guard interval is defined as a proportion of the useful interval  $T_u$ . The maximum length of guard interval for the 8k-mode is 224  $\mu$ s compared with 56  $\mu$ s for the 2k-mode. The guard interval is used to protect the signal from natural and artificial (SFN) echoes. The smallest 2k guard interval (7  $\mu$ s) is usually sufficient to protect the signal from natural echoes; only in some cases, such as mountainous areas, are natural echoes longer than 7  $\mu$ s.

The main parameters for the choice of guard interval length are station separation distances and the size of the SFN. The choice of number of carriers mainly depends on the question whether the network will be some kind of SFN or not. If no SFN transmitters are to be included the available guard interval lengths of the 2k-mode are usually sufficient for the system to be rugged against natural echoes, although if very long echoes are expected a higher bit rate can be achieved with the 8k-mode.

There are in principle 4 kinds of SFN:

- Large area SFN (with many high power transmitters and large transmitter spacing);
- Regional SFN (with few high power transmitters and large transmitter spacing);
- Multi Frequency Network (MFN) with a local dense SFN around each MFN transmitter (one existing site plus a number of medium power SFN transmitters and medium transmitter spacing);
- SFN gap fillers (low power transmitters to fill in a small gaps in the coverage area of an MFN).

The 8k-mode can cope with all of these SFN situations. The 2k-mode can cope with SFN gap fillers. It may also cope with dense MFN/SFNs if the transmitter spacing is small enough (four times more close than the corresponding 8k transmitter spacing). The maximum possible transmitter spacing depends not only on the absolute length of the guard interval, but importantly on other factors such as the length of the useful interval  $T_u$  (significantly better coverage with 8k than 2k with the same absolute guard interval length, e.g. 56  $\mu$ s), signal constellation, code rate and receiver implementation.

For a given length of guard interval therefore the 8k-mode provides a higher net bit-rate. The choice between the two modes depends on the need for SFN operation in the overall network and the availability and cost of receivers. Receivers built for the 2k-mode (only) cannot receive 8k transmissions. Dual mode 2k/8k receivers will however be able to receive both 2k and 8k transmissions.

### 4.1.3 Choice between hierarchical and non-hierarchical mode

The DVB-T (see EN 300 744 [5]) specification makes it possible to choose between a hierarchical and a non-hierarchical transmission mode. This possibility is reflected in figure 5 showing the functional block diagram of such a system, and indicating the signal processing in the transmitter stage.

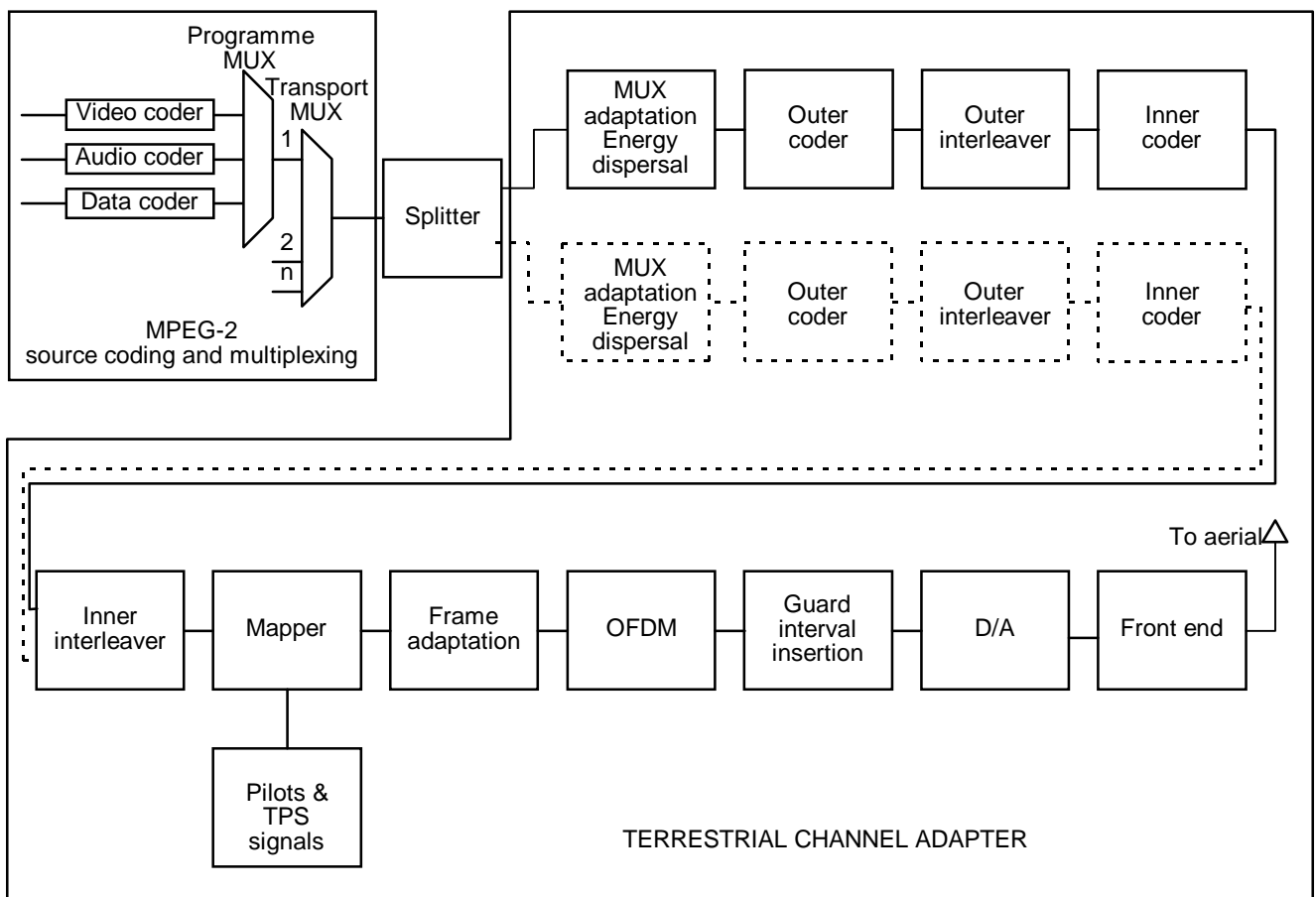

Figure 5: Functional block diagram of the system

For hierarchical transmission, the functional block diagram of the system has to be expanded to include the modules shown dashed in figure 5. The splitter separates the incoming transport stream into two fully compliant Moving Picture Experts Group (MPEG) transport streams, referred to as the high priority stream and the low priority stream. These two bit-streams are then mapped onto the signal constellation by the mapper and modulator which have to provide an appropriate number of inputs.

As far as hierarchy is concerned the DTB-T system restricts itself to hierarchical modulation and channel coding. Within the system, there are no means for hierarchical source coding. This enables the receiver to be designed very economically.

As shown in figure 5, a programme service can be split into two separate bit-streams that are then fed to the mapper. A programme service thus could be broadcast as a low bit-rate, rugged version together with another version of higher bit-rate and less ruggedness. This mode is referred to as the "simulcast mode". Alternatively, entirely different programmes could be transmitted on separate streams with different ruggedness. In each case, the receiver requires only one set of inverse elements: inner de-interleaver, inner decoder, outer de-interleaver, outer decoder and multiplex adaptation. The only additional requirement of the receiver is the ability for the demodulator/de-mapper to produce one stream selected from those at the sending end.

The basic features as well as preferred applications for both of these modes will be explained in the following chapters.

#### 4.1.3.1 Non-hierarchical mode

Referring to figure 5, the non-hierarchical mode requires only the solid signal processing path. As the splitter is no longer necessary for that application, all MPEG transport packets will undergo the same interleaving and channel coding procedure and will then be mapped onto the appropriate constellation pattern. This means that all MPEG transport packets will be equally treated by the modulator and will thus be equally rugged while being transmitted. As the packet payload will be scrambled due to the interleaver modules, there is no predetermined relationship between a particular bit of the packet payload and the position of that bit in the constellation diagram. In other words, the channel encoding procedure does not allow for particular bits of the MPEG packets to be mapped onto specific positions in the constellation diagram. Thus, it is of no benefit to use non-uniform modulation parameters for the modulator, so a uniform modulation factor ( $\alpha = 1$ ) is mandatory for non-hierarchical transmission mode.

The non-hierarchical transmission mode does not necessarily imply that only one programme can be broadcast at a time. It is likely that several programmes will be transmitted within one OFDM signal, i.e. in one RF channel (multi-programme mode); depending on the MPEG transport multiplex, several programmes can be transmitted as long as their capacity requirements do not exceed the available bit-rate of the chosen transmission mode. In the non-hierarchical transmission mode, all MPEG transport packets are processed and encoded in the same way leading to an equal grade of ruggedness for all programmes within that stream.

To receive one complete programme of the received stream, the receiver has to select the desired programme by identifying the appropriate MPEG transport packets after demodulation. This is performed by the demultiplexer which is incorporated in the receiver to ensure exactly this capability.

Typical applications of non-hierarchical modes can generally be divided into multi- and single-programme transmissions. Single programme modes are mainly dedicated for applications where the transmission constellation requires the full bandwidth for one transmitted programme, e.g. to achieve high quality or a large coverage area. For multi-programme transmission, on the other hand, the channel capacity is shared by more than one programme. A typical example would be a multiplex of four different programmes. It is the network provider who chooses the appropriate modulation and channel code for the multiplex.

#### 4.1.3.2 Hierarchical mode

As noted above, the DVB-T system enables the possibility of a hierarchical transmission mode which can be considered as an opportunity to transmit a service multiplex in two independent channels which can thus be protected differently in order to optimally match the channel or coverage requirements.

Two different modes are feasible for this mode, which are referred to as "simulcast" and "multi-programme" broadcast.

Simulcast transmission principally carries one or more programmes which are identically covered in two complete separate MPEG transport streams, a low bit-rate stream and a high bit-rate stream. The low bit-rate stream will usually be encoded with a high grade of redundancy, i.e. low code rates (for example 1/2 or 2/3) and will be mapped onto those non-uniform constellation points which show utmost robustness among all other positions. Preferable positions for that

purpose are the four quadrants in the case of a QPSK modulation in combination with  $\alpha > 1$ . These two provisions together will enable high robustness during transmission. For that reason, the associated low bit-rate stream is referred to as the High Priority (HP) stream. It carries data, which should be received even under poor or difficult channel conditions such as portable reception or reception at the border of coverage area.

Conversely, the other bit-stream carries the same programme content with a higher bit-rate, which most likely has been derived by a different MPEG encoding process. The recovery of this Low Priority (LP) stream at the receiver will of course lead to a better quality on the display, but will require better reception condition for error-free decoding. Depending on the antenna installation and the reception conditions, the receiver is able to decode the most convenient bit-stream, either the low or the high priority one.

An example of the system performance for both different streams is given in figure 6, which shows the bit error rate versus the carrier to noise ratio for the low and the high priority stream.

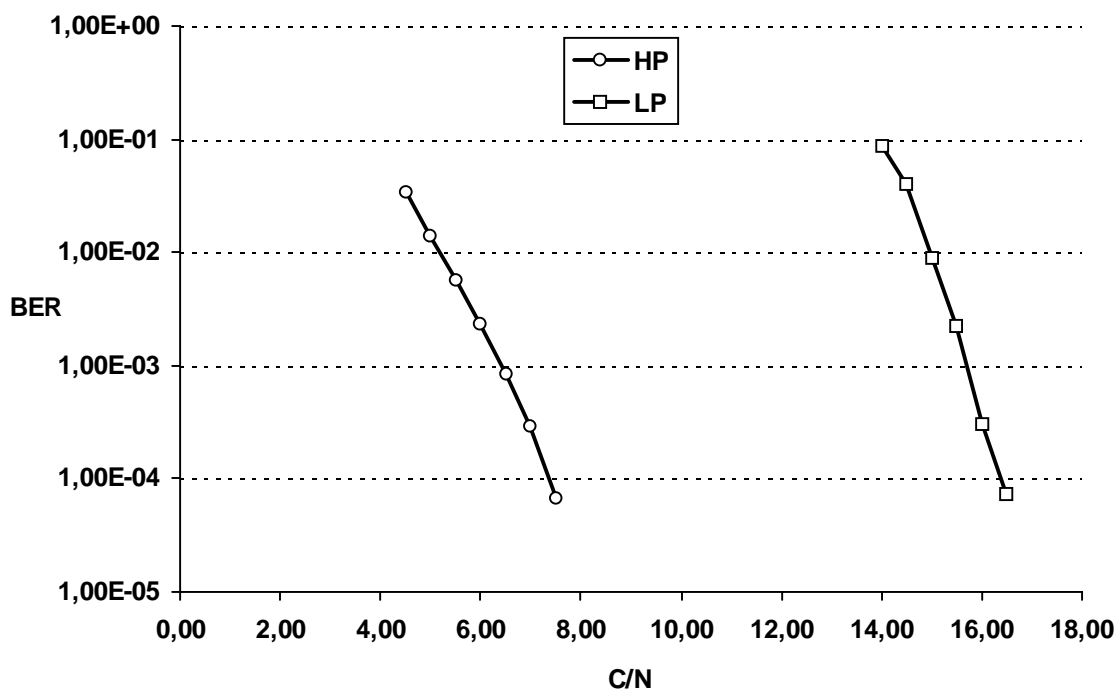

**Figure 6: System performance for low and high priority bit-stream in a hierarchical transmission scenario (parameters:  $\alpha = 2$ ; HP: QPSK,  $r=2/3$ ; LP: 16-QAM,  $r=3/4$ )**

It can be seen from figure 6 that the LP stream needs a better carrier to noise ratio in order to obtain the same bit error rate as the HP stream. Parameters to be modified are the modulation factor  $\alpha$ , which, if increased, will make the HP stream a little bit more robust but will shift the LP curve to higher carrier to noise ratios. A second parameter is the code rate which will control the ruggedness against available bit-rate.

The shape of the curves shown in figure 6 would not change very much, but their position in the diagram depends on the parameter setting. That is the reason, why only one outstanding point is necessary in order to indicated the total performance of one curve. In the DVB-T system specification, this particular point has been chosen as the necessary carrier to noise ratio in order to provide a BER of  $2 \times 10^{-4}$  after Viterbi decoding. This is the threshold for a proper operation of the succeeding Reed-Solomon decoder. A table comprising all values for all possible parameter setting is provided on the DVB-T specification (see EN 300 744 [5]).

Given the fixed shape of the performance curves themselves and knowing the threshold value for the carrier to noise ratio, one can deduce all possible performance curves which can be derived from the variation of suitable system parameters. It will be up to the broadcasters and/or network provider to choose an appropriate parameter constellation.

It has to be pointed out that this simulcast mode should not be seen as a graceful degradation approach, since the price for the receiver economy is that reception can not switch from one stream to the other (e.g. to select the more rugged stream in the event of reception becoming degraded) while continuously decoding and presenting pictures and sound.

A pause is necessary (e.g. video freeze-frame for approximately 0,5 s and audio interruption for approximately 0,2 s) while the inner decoder and the various source decoders are suitably reconfigured and re-acquire lock. As a result, the simulcast mode is dedicated to decode either the low priority or the high priority stream. A favourable application is that one programme can be decoded by portable receivers with reduced quality while fixed antenna receivers are capable to recover the same programme content with enhanced sound and display quality.

Applications for hierarchical transmission are not only restricted to simulcast operations. As shown in the functional block diagram of figure 5, the low priority bit-stream does not need to contain the same programme, but may carry one or more totally different programmes. The behaviour of the DVB-T system regarding performance of multi-programme operation is similar to that of the simulcast system, i.e. performance figures can be derived from the appropriate modulation scheme being either the QPSK modulation for the HP stream or the QPSK or 16-QAM modulation for the LP stream.

One attractive transmission scenario for multi-programme operation is the robust transmission of a programme that can be decoded by a portable receiver. In addition to that, a fixed receiver with a directive antenna would be able to also decode the LP stream providing additional programmes with nearly the same quality compared to that of the HP one. Following the general conclusion of the simulcast mode, it will be up to the broadcaster and/or network provider to choose the suitable transmission parameter setting for the trade-off between available bit-rates and robustness. The parameter of robustness of course is directly convertible in an appropriate coverage area. Again, by means of applying a specific set of transmission parameters for both the HP and the LP stream, the broadcaster is able to serve an appropriate coverage area.

#### 4.1.4 TPS explanation (use of TPS)

The Transmission Parameter Signalling (TPS) information is mapped onto specific carriers within the OFDM frame. This information is transmitted for the benefit of the receiver and is used for signalling parameters related to the transmission scheme. These parameters are:

- frame number in a superframe;
- modulation scheme;
- hierarchy information;
- inner code rates;
- guard interval length;
- transmission mode.

The information listed above is conveyed in a block of TPS pilots. The number of TPS pilots in one OFDM frame depends on the transmission mode: 17 TPS blocks are transmitted in parallel for the 2k-mode and 68 TPS blocks are transmitted in parallel for the 8k-mode. Figure 6 shows an OFDM frame with TPS pilots at the black marked positions. A column of the black marked positions builds one TPS block.

The number of information bits transmitted in a TPS block is equal to the number of TPS pilots in a TPS block because each TPS pilot is coded by one information bit. For the security that a TPS block will be received and decoded correctly a TPS block is transmitted in parallel on different carrier positions as shown in figure 7. That is why each OFDM symbol (located in a row in figure 7) conveys only one TPS information bit but more than one TPS pilot.

⇒ *TPS pilots in the same OFDM symbol convey the same information.*

The TPS information bits for modulation scheme, hierarchy information, inner code rate, guard interval and transmission mode transmitted in the actual superframe  $m$  (a superframe is a set of four frames) always apply to the following superframe  $m + 1$ . All other bits refer to the actual transmitted superframe  $m$ .



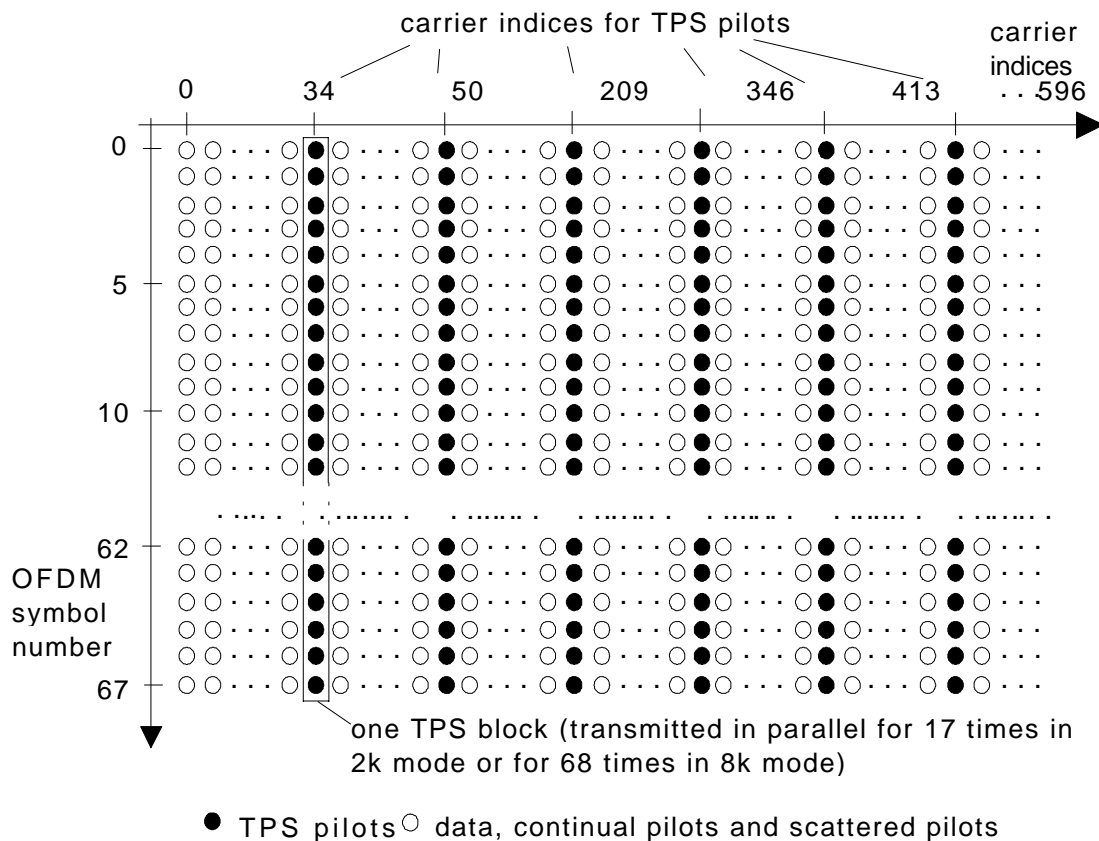

Figure 7: Location of TPS pilots in a frame containing data signals and pilots

## 4.2 Transmitter input signal

The transmitter input signal is specified as an MPEG-2-TS multiplex (see ISO/IEC 13818-1 [9]), which may contain several TV programmes and also possibly some sound/data only programmes. This subclause gives some guidance on the bit-rates needed for services and explains some of the terms relevant to the MPEG-2 multiplex, it also explains how the DVB-T (see EN 300 744 [5]) specification relates to the Cable (DVB-C EN 300 429 [4]) and Satellite (DVB-S EN 300 421 [3]) specifications. Clause 8 covers the synchronization requirements that need to be imposed in SFN operation.

### 4.2.1 MPEG-2-TS multiplex signal

#### 4.2.1.1 Services and bit-rates

The DVB-T (see EN 300 744 [5]) specification offers a range of deliverable bit-rates from 4,98 Mbit/s to 31,67 Mbit/s. In planning a service it is important to have an idea of the bit-rates needed for different kinds of service. Because the impairments of MPEG-2 video coding are very different from those of analogue coding and transmission it is difficult to specify bit-rates giving quality equivalent to today's television. As a very general guide, most non-critical programmes can be satisfactorily coded with 4 to 4,5 Mbit/s for the video component whilst for prestige broadcasts or critical material (e.g. sport) at least 6 Mbit/s may be necessary. Improvements in MPEG coding might reduce these figures by 10 % over the next few years, but such improvements are more likely to improve the small proportion of scenes where present coders fail dramatically rather than to make a significant difference to the quality of average scenes. Further improvements are likely to require new coding techniques that would not be compatible with today's MPEG decoders. Stereo audio may be coded in as little as 192 kbit/s (although pseudo-surround-sound systems such as Prologic will require more). Standards for multi-channel surround sound are currently being debated; bit-rates between about 400 kbit/s and about 900 kbit/s have been suggested, depending on the coding technique used and whether it is

backwards compatible with stereo-only decoders (if this compatibility is required, the bit-rate will be towards the higher end of this range).

Viewers are used to selecting TV programmes by selecting an RF channel. Since digital broadcasting offers several programmes in a single channel, some kind of Electronic Programme Guide (EPG) is essential to help viewers to navigate between the programmes offered. The bit-rate needed for an EPG depends on the Applications Programming Interface (API) chosen for the receiver, but could be as little as 0,25 Mbit/s to 0,5 Mbit/s.

Although it may be convenient to allocate a constant bit-rate to each service, it is not essential to do so. Some existing MPEG coding and multiplexing equipment allows dynamic control of the bit-rate for each service; however, implementing such dynamic multiplexing may impose some technical constraints - for example it would probably be necessary for the MPEG-2 coders and the multiplexer to be physically close to each other and controlled by the same computer. Dynamic multiplexing will also cause additional difficulties with downstream drop-and-insert multiplexing such as would be needed in a regional network.

#### 4.2.1.2 Some technical background

The MPEG-2 *Transport Stream* (TS) contains one or several *Programmes*. A programme, in MPEG terms, is a single broadcast service such as BBC-2 or RAI Uno, not an individual TV programme as broadcasters normally use the word. A programme comprises one or more *Packetized Elementary Streams (PES)*, each containing a single digitally coded component of the programme, for example coded video or coded stereo audio; it will also contain *time stamps* to ensure that specified elementary streams are replayed in synchronism at a decoder. In the TS there are also tables of *Service Information (SI)* giving details of the multiplex and the nature of the various elementary streams, access control information and *Private Data* channels whose content is not specified by MPEG such as for Teletext or broadcasters' internal communication and control channels.

The TS was devised for multi-programme applications in error-prone channels such as broadcasting. It comprises a succession of packets, each 188 octets long, called *Transport Packets*. Each transport packet carries data relating to one elementary stream only. No error protection is specified by MPEG, but appropriate protection such as a Reed-Solomon code and packet interleaving can easily be applied to the TS to suit the expected error characteristics of the transport medium.

The bit-rate of the TS is determined by the application. An MPEG multiplexer inserts null packets to adapt the sum of the bit-rates of its inputs to the required output bit-rate.

The physical layer (serial/parallel, signal levels, connectors, etc.) is not specified by MPEG. In DVB however, TS interfaces for broadcasting applications are standardized (see EN 50083-9 [8]).

### 4.2.2 Relation to DVB-C and DVB-S signals

The DVB-T (see EN 300 744 [5]) specification is one of a family of specifications including DVB-C (see EN 300 429 [4]) for cable systems and DVB-S (see EN 300 421 [3]) for satellite broadcasting. All use MPEG-2 coding for video and audio and MPEG syntax for multiplexing. They all use the Reed-Solomon RS(204,188, t=8) code which allows correction of up to 8 random erroneous bytes in a received word of 204 bytes. However, the satellite specification adds an inner error correction code and for the terrestrial specification the error correction coding of the satellite specification, frequency and bit interleaving are added. The methods of modulation are also different, being adapted to the characteristics of the channels.

However, from the operational point of view, the main difference is that the satellite and cable specifications allow higher bit-rates (35-40 Mbit/s); thus conversion between either satellite or cable and terrestrial specifications will involve an MPEG remultiplexing operation, dropping services if converting to the terrestrial specification and adding services (or null packets) if converting from the terrestrial specification. The SI data will have to be revised at the remultiplexer to reflect the changed content of the multiplex and the change of delivery medium.

## 4.3 Transmitter output signal

### 4.3.1 Power definition as RMS value

The output signal of a DVB-T transmitter consists of thousands of carriers modulated in phase and amplitude. Therefore it resembles a Gaussian noise signal. It should be noted, however, that very high peaks of the sum signal are limited due

to effects in the process of generating and amplifying the signal. The only simple way to define the power of a COFDM signal like DVB-T is an RMS definition. It is also closely linked to the theoretical system analysis.

As the number of carriers of a given DVB-T system (either 2k or 8k) is constant and all carriers have defined power, the total power of a DVB signal is the sum of all carrier power values. In practice only the total power can be measured. In principle one symbol is insufficient for assessing the power. With thermal power meters the integration time constant is much larger than a symbol period allowing valid measurements.

### 4.3.2 Spectrum mask to limit adjacent channel interference

The nominal bandwidth of a DVB-T signal is approximately given by the product of the number of carriers and the intercarrier distance. Adjacent to the signal within the nominal bandwidth the spectral density does not completely vanish but exists at a level which is dependent on the prefiltering after signal generation, the non-linear distortion of the power amplifier and the filtering after this amplifier.

The side lobes of the DVB signal extend into the adjacent channels and consequently interfere with signals in this channels. Different network configurations and different systems which suffer out-of-band interference require specific attenuation of those side lobes. EN 300 744 [5] on DVB-T provides examples for co-sited analogue TV-transmitters.

It should be noted that the spectrum masks are expressed as the attenuation of a 4 kHz portion compared to the total symbol power at a given frequency outside the nominal bandwidth in order to comply with the general usage of interference considerations.

### 4.3.3 Characterization of behaviour for planning by protection ratios

In planning terrestrial transmitter networks or even single transmitters an important aspect is the mutual interaction of different transmissions, either of the same system or of different types. To simplify the matter a single technical term is used: the protection ratio. It is the ratio of the wanted signal power to the interfering signal power for a given degree of subjective or objective degradation of the wanted signal. The chosen degradation is often the limit of allowed degradation for a reception point to be considered as belonging to the service area. There are different levels of acceptability for the degradation depending on its duration, the "continuous" protection ratios apply for 50 % of time, whereas the "tropospheric" protection ratios apply for only 1 % of time.

The protection ratios have to be determined for all relevant combination of signals. The measurement is normally done in a well defined laboratory environment. While the so-called co-channel-protection ratios are mainly system dependent, the so-called adjacent-channel protection ratios are dependent on the out-of-band parts of the signal (see subclause 4.3.2) and the spectrum filtering in the receiver. During the system implementation the properties of receivers may change and consequently protection ratio measurements should be undertaken from time to time to follow the technological development.

---

## 5 Basic aspects of DVB-T networks

### 5.1 MFN or conventionally planned networks

#### 5.1.1 Principle of MFN

Conventionally planned DVB-T networks consist of transmitters with independent programme signals and with individual radio frequencies. Therefore they are also referred to as Multi Frequency Networks (MFN). Whether a number of transmitters is considered to belong to a specific network is an administrative matter rather than a technical one. In order to cover large areas with one DVB-T signal a certain number of radio-frequency channels is needed. The number of channels depends on the robustness of the transmission, i. e. the type of modulation associated with the applied channel code rate and on the objective of planning, (full area coverage or coverage of densely populated areas only).

## 5.1.2 Frequency resources needed for MFN

As the robustness of a broadcasting system is generally expressed in terms of protection ratios, one might expect that the number of channels needed for DVB-T is significantly lower than for analogue broadcasting as the protection ratios are generally lower in the digital case. However, due to the "brick-wall behaviour" of digital signals the direct application of the planning rules for analogue transmission is not appropriate without an extra allowance of the order of 10 dB to 20 dB (to be verified by field tests) for the local variation of the signal strength. Therefore the number of radio-frequency channels needed for conventionally planned DVB-T networks tends to be in the same order as with analogue TV systems. The frequency resource expressed as the number of channels needed to provide one signal at any location is far higher with MFN than with Single Frequency Networks (SFN).

Depending on how intensively the frequency bands for analogue TV are used, some DVB-T transmitters may be added without significant impact on the existing services. Accepting this prerequisite, only local services with restricted service areas may be possible in a given country. However, this may be considered as a starting scenario, which can be extended to achieve wider coverage later on when analogue services are to be faded out gradually.

The allocation of radio frequency and radio power for each transmitter needs thorough calculation of the mutual interference of all transmitters inside and outside the network according to internationally agreed rules.

Each time a non-covered area is to be included in the service a new process of finding and co-ordinating a frequency for this area is necessary (see clause 9 on network planning).

## 5.1.3 Non-synchronous operation

The transmitters in an MFN have not to obey rules of synchronous emissions. Therefore no co-ordination between transmitter operators is absolutely necessary. The installation of local or regional services is easy with the MFN concept compared to the SFN concept. In an SFN it is not possible to provide an extra service for only a part of the common service area. Regional services however, can also make use of the SFN concept employing only few transmitters.

## 5.1.4 Excess power

Due to terrestrial propagation effects, the received power at a given distance from the transmitter varies significantly with location and, to a much smaller extent, with time. As digital transmission does not degrade gracefully as power level reduces, but suddenly breaks down, increased transmitter power is needed to compensate for these variations., especially at the edge of the service area. Possible values for this increase in power are of the same order as are considered for the increment of the protection ratios (see subclause 5.1.2), i.e. 10 to 20 dB.

If full area coverage is achieved by overlapping the service areas of adjacent transmitters, the location variations of signal strength from different transmitters may not be strongly correlated, so that not all transmitter signals will suffer the same attenuation at a given location in the overlap area. Thus the receiver may choose the strongest signal and excess power is not needed to the extent mentioned above.

Location variation may also be reduced by the use of SFN techniques as described in subclause 5.3

# 5.2 Single Frequency Networks (SFN)

## 5.2.1 Principle

In a SFN, all transmitters are synchronously modulated with the same signal and radiate on the same frequency. Due to the multi-path capability of the multi-carrier transmission system (COFDM) signals from several transmitters arriving at a receiving antenna may contribute constructively to the total wanted signal.

However, the limiting effect of the SFN technique is the so-called self-interference of the network. If signals from far distant transmitters are delayed more than allowed by the guard interval they behave as noise-like interfering signals rather than as wanted signals. The strength of such signals depends on the propagation conditions, which will vary with time. The self-interference of an SFN for a given transmitter spacing is reduced by selecting a large guard interval. It should be noted that the impact of delayed signals outside the guard interval may depend on receiver design. As an empirical rule, to successfully reduce self-interference to an acceptable value the guard interval time should allow a radio signal to propagate over the distance between two transmitters of the network.

In order to keep the redundancy due to the guard interval down to a reasonably low value (25 %), the useful symbol length has also to be large given the transmitter spacing in most European countries. Thus the 8k-mode was introduced. On the other hand a smaller guard interval would lead to a higher number of transmitters.

## 5.2.2 Frequency efficiency

With the SFN technique large areas can be served with a common multiplex at a common radio centre frequency. Therefore the frequency efficiency of SFNs appears to be very high compared to MFNs. However, taking into account the presence of similar networks offering other programme multiplexes in adjacent areas, further radio frequency channels are required. The number of channels needed for international co-ordination is 4 at minimum, in practice 5 or 6 are realistic (see also clause 9 on network planning).

Gaps in the coverage area of an SFN are easily filled by adding a new transmitter without the need for additional frequencies.

## 5.2.3 Power efficiency

The SFN technique is not only frequency efficient but also power efficient. This can be explained by considering the strong local variations of field strength of any given transmitter. In conventionally planned networks and particularly in single transmitter situations, a common way to achieve service continuity at a high percentage of locations is to include a relatively large fade margin in the link budget and thus to increase the transmitter power significantly. However with omni-directional reception in SFNs, where the wanted signal consists of several signal components from different transmitters the variations of which are only weakly correlated, fades in the field strength of one transmitter may be filled by another transmitter. This averaging effect results in smaller variations of the total field strength. Accordingly SFNs can use lower powered transmitters. This power efficiency of an SFN is important in the fringe area of a given transmitter and is often called "network gain". The benefit occurs only for reception on low-gain, omni-directional antennas as are often associated with portable reception. Conventionally planned networks offer a corresponding benefit only if the receiver is tuned to the frequency of the strongest signal after each change of location.

## 5.2.4 Synchronous operation

A price to pay for frequency and power efficiency is the synchronous operation of all transmitters in a given network. Achieving synchronism of all transmitters needs specific provisions (see clause 8 on SFN operation). In networks for large area coverage with 8k-mode and guard interval of  $\frac{1}{4}$  (i.e. 224  $\mu$ s), tolerances of  $\pm 5 \mu$ s should not cause performance degradation. The requirement of synchronous transmitter operation has significant impact on the distribution of the programme multiplex signal to the transmitters (see subclause 7.1 on primary distribution).

In irregularly spaced networks the self-interference may be minimized by a specific time offset of certain transmitters (see clause 9 on network planning).

The synchronous operation of all transmitters in an SFN does not preclude altering any part of the modulation signal at any transmitter within the SFN, e.g. to install a local service inside the network. The difference in the modulation signal causes the transmitter in question to turn to an interferer affecting the surrounding transmitters for the duration of signal difference.

## 5.3 MFN with local dense SFN around each MFN transmitter

Also in an MFN, based on an existing transmitter infrastructure, a system mode capable of SFN operation may be of great importance, since it allows for a future gradual improvement in coverage in general and portable coverage in particular without new frequency assignments being necessary. By introducing additional medium to high power SFN transmitters (with separate feeding) around a main transmitter a local dense SFN is achieved. In general 8k operation is needed for this kind of application, unless the transmitter spacing is in the order of 15 km, where a 2k-mode with 56  $\mu$ s guard interval is conceivable.

## 5.4 Gap-filler

If gaps exist in a service area, as may be encountered in deep valleys, tunnels, subterranean locations or inside houses, the multipath capability of DVB-T enables these gaps to be filled in a very efficient way. It is also possible to extend the

service area by such re-transmitters (see subclause 8.2.1 and figure 11) without additional costs for primary distribution and modulators.

The principle is as follows: outside the gap or the uncovered sub-area the DVB-T signal is picked up by a directional antenna. After filtering and amplification the signal is retransmitted (at the same frequency) into the uncovered area.

The most important precondition for application of a gap-filler is a sufficient isolation between the antennas. To prevent the re-transmitter from oscillating, the gain of the re-transmitter has to be less than the feedback.

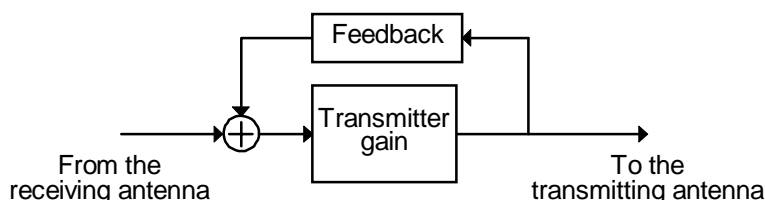

**Figure 8: Principle of a re-transmitter**

### 5.4.1 Professional gap fillers

A professional gap-filler should have sufficient power to provide coverage for an otherwise uncovered area. The maximum possible radiated power depends on both the isolation between the reception antenna and the transmitting antenna and the performance of the power amplifier of the repeater.

The antenna isolation depends on:

- the height and dimension of the tower or building where the repeater is located;
- the position of the antennas on the tower or building;
- the radiation diagram of the antennas;
- the location of the area which should be covered in relation to the direction to the main transmitter;
- the environment around the repeater (buildings or other objects which could cause multipath).

In addition to the general problem of isolation explained above, even if the feedback is lower than the amplifier gain, a decrease in the system performance has to be expected. Among all reflections there will be one dominating path coming either from the limited isolation between the antennas and/or the feedback from reflectors around the repeater station. In general, there is a time delay between the input and the output of a gap-filler, mainly due to the SAW-filter within the device. This will cause frequency selective attenuation of the retransmitted signal similar to the characteristic of a two-path or multipath reception, resulting in a degradation of system performance. Practical tests show however that this effect is negligible if the frequency selective attenuation does not exceed 10 dB.

As mentioned before, the isolation depends on the overall design of the place where the repeater is installed. Experiments have shown that a sufficient isolation can be reached if a large radio tower made by concrete is used as a repeater station. Isolation values about 80 dB are realistic. If there are more levels (like platforms where antennas may be fixed) it is helpful to install the antennas at different levels.

### 5.4.2 Domestic gap fillers

The domestic gap-filler is a device to amplify the signal from a domestic roof-top antenna and re-transmit it inside the house, thereby overcoming the building penetration and height-gain losses. This allows portable reception inside houses in areas with low field strength.

As the field strength in rooms has to be no higher than outside the building there should be no problem with EMC. However limits for human exposure to electromagnetic radiation has to be respected.

For a domestic gap-filler two implementations are being considered, the first one is a broad-band amplifier, the second one is a filtered version.

The possibility to convert to Intermediate Frequency (IF), filtering and up-conversion has been evaluated to be too costly for consumer use and would have the disadvantage of being suitable for one channel only.

Early tests have indicated that the concept of a domestic gap-filler is practically feasible.

The main aspect to be considered is the isolation between the receiving and transmitting antennas. In cases of MATV reception the isolation does not seem to be a problem. Tests in houses with individual antenna reception have shown that good isolation can be achieved in the case of a roof-top receiving antenna, but may be more difficult with the receiving antenna in the loft.

Another potential problem is that in regions where the digital signals are interleaved with the analogue channels, the analogue signals could be amplified as well and could cause problems for portable analogue reception.

In any case it is clear that there is a need to carry out more tests taking into account not only the reception conditions (MATV network, individual roof-top, loft or even indoor antenna) but also the various penetration losses presented by the different materials (concrete, wood, etc.) used in European houses.

---

## 6 Setting up DVB-T transmitters

### 6.1 RF issues, existing sites/sharing with analogue

The digital TV transmitters will, in general, re-use the same sites as existing analogue TV transmitters. It is important to introduce digital terrestrial TV with technical and economical constraints as low as possible taking into account the current situation of the existing analogue network.

Wherever possible, channels for digital broadcasting from a particular site are selected close to the analogue channels. In many cases this should allow viewers to re-use their existing receiving antenna system. During the introduction of digital services, it is important not to place unnecessary difficulties in front of potential viewers.

As it is envisaged using the adjacent channels of analogue transmitters for digital TV broadcasting, the knowledge of the level of spurious emissions on these channels is of major interest. TV transmitters and especially high power TV transmitters produce out-of-channel emissions (spurious emissions). Great care is generally taken in the design of the low power stages of the transmitters in order to avoid such emissions, but the non-linearity of the power amplifiers generates emissions outside the nominal channel and particularly in the adjacent channels.

In the adjacent channels, spurious emission of analogue transmitters will be seen by the digital receivers as co-channel interference.

Several studies on this topic remain to be carried out.

In order to minimize such spurious emissions, filters have to be used either at transmitter output or using RF selective combiners.

If the existing antenna can be used two different implementations can be encountered:

- the first is to use RF combining for both high power and secondary sites;
- the second is an alternative solution dedicated to secondary sites which consists of using multi-channel amplification.

#### 6.1.1 Use of existing antenna

In such a case, the channels chosen for digital terrestrial TV have to be inside or close to the bandwidth for which the analogue antenna has been matched. Hence, the use of the same antenna for analogue and digital channels can bring a similar coverage area for both services. More of all, most of the existing reception antennas should be suitable. On the other hand, possible ERP restrictions necessary to protect existing analogue channels broadcast from neighbouring sites cannot be satisfied.

Existing antenna and feeders have to support the total multiplex power including all the peak power of digital channels.

The cascading architecture leading to the multiplex of both analogue and digital channels can be problematic especially concerning adaptation losses. In this case, it will be necessary to define the relevant Equivalent Noise Degradation (END).

### 6.1.1.1 RF combining

In many cases it will be useful to allocate the digital TV broadcasting band in adjacent channels of the existing analogue TV broadcasting channels. Under such conditions, considering the useful bandwidth of the DVB-T signal (7,61 MHz) to be included in a ITU-R channel (8 MHz in UHF), the selectivity of the combiner becomes a critical point.

As shown in the figure 9, the combiner comprises two 3 dB couplers, two identical band pass filters and a dummy load. It has a selective input called "narrow band" and a "broadband input". The band pass filters are tuned to the narrow band input channel.

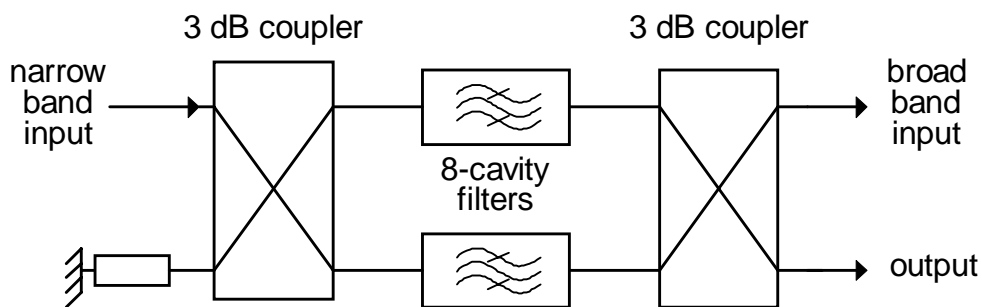

**Figure 9: RF DVB-T combiner**

In this case, a digital signal is connected to the narrow band input and analogue channels are connected to the broadband input.

The digital signal is split two ways by a 3 dB coupler and passes through the two identical band pass filters. The two halves of the signal are then recombined by the second 3 dB coupler and passed on to the antenna.

Any reflections from the filters, or any analogue signals leaking through are dissipated in the load.

Similarly, the analogue signal (PAL or SECAM) is split two ways by a 3 dB coupler. This time, however, the two halves of the signal are reflected from the filters and recombined by the same 3 dB coupler before passing on to the antenna.

The filters are required to pass the digital signal, yet block the channels of the broadband and especially the adjacent channel which is the more critical. Nevertheless, the use of filters leads to a group delay variation which is source of signal distortion. This distortion is directly related to the filter selectivity. In order to avoid such a problem, a baseband pre-corrector has to be used.

### 6.1.1.2 Multi-channel amplification

Secondary networks are intended to be sets of low power transmitters and repeaters used to complete the main sites coverage.

Introduction of digital channels on secondary sites will lead to similar issues as those encountered on main sites.

The two classical options envisaged are the installation of new antennas, dedicated to digital channels, or the implementation of RF combiners.

Besides these classical issues, we focused on an alternative technique, called multi-channel amplification, experimented to ease digital channels introduction. Its main concept is to combine digital or analogue channels before amplification, which can be done with a low cost and non selective couplers.



As illustrated in figure 10, the treatment of the TV channels is achieved using the following procedure:

- reception of the channels by means of antennas;
- filtering and conversion of input channel in Intermediate Frequency (IF);
- intermediate frequency treatment (use of adequate SAW filter for the adjacent channel treatment);
- IF/RF conversion;
- low power channel coupling;
- multiplex power amplification.

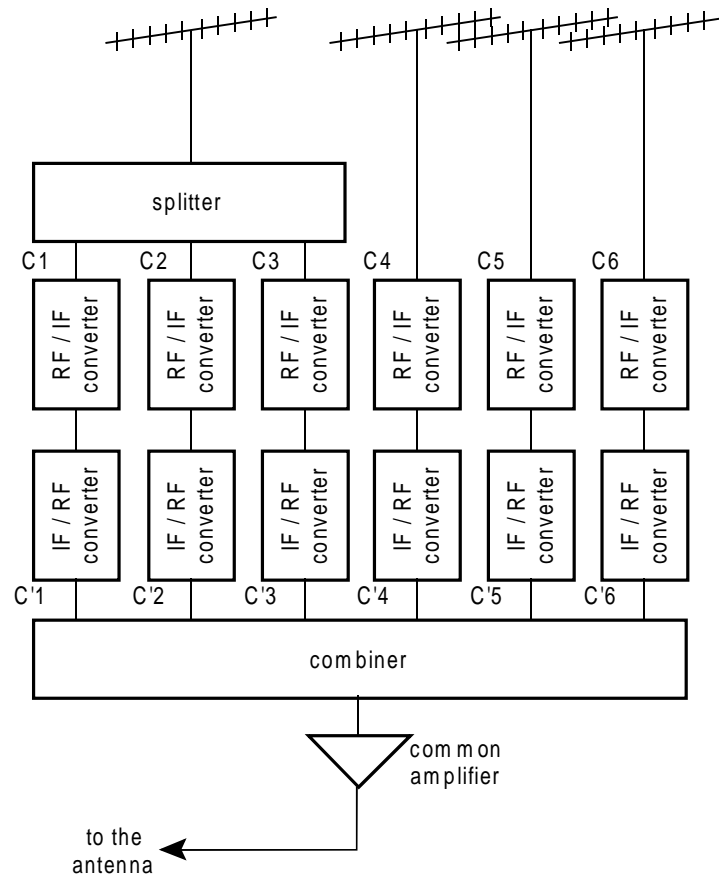

**Figure 10: Typical structure of the multi-channel repeater site**

The treatment of the channels before power amplification is then achieved by means of typical cable network equipment.

Multiplexing of the channels is simple, versatile and perfectly adapted to the addition of digital channels.

The multi-channel amplification can really ease digital channels introduction. Further studies remain to be carried out in order to assess the economical advantages of such an architecture, compared to the current analogue existing one.

### 6.1.2 New antenna dedicated to digital terrestrial TV

Firstly it is necessary to find an available location for a new antenna on the existing mast structure. In most cases the available aperture on existing structures is not convenient for ideal UHF use because of a more important cross-section. With these large cross-sections designing a wideband antenna is extremely difficult.

The main advantage of such a situation is the absence of high power RF combiner but the drawback is the spurious emissions which are not filtered. Therefore it could be necessary to use specific filters at the transmitters output.

For the new antenna diagram leads thus to a different coverage area from the analogue one.

The bandwidth and matching of the antenna are specifically adapted to the broadcast of digital channels.

ERP restrictions may be required in order to protect the existing analogue TV services.

Because of all these reasons, the cost of a new antenna can be high.

---

## 7 Setting up DVB-T distribution networks

### 7.1 Basic aspects of primary distribution

The primary distribution network (sometimes also called the transport network) carries the digital TV signal from the TV production premises to the transmitter sites (the broadcasting or secondary distribution network). This subclause reviews the possible methods of primary distribution; practical networks may use a mixture of several of the possibilities described.

#### 7.1.1 Centralized generation of the COFDM signal

The COFDM modulator may be at a central point and the modulated COFDM signal distributed to the transmitters using terrestrial analogue SHF links. A standard Frequency Modulation (FM) SHF link as used for analogue PAL or SECAM signals can be used for distribution of COFDM signals with reasonable performance over distances up to about 20 km. The performance could be improved by modifying the link equipment to remove the ITU-R Recommendation 405 [11] pre/de-emphasis and other circuitry not necessary for COFDM transmission and by improving local oscillators to reduce phase noise. Analogue satellite distribution of the COFDM modulated signal is also technically possible.

#### 7.1.2 Decentralized generation of the COFDM signal

The MPEG-2-TS has to be distributed to all the COFDM modulators in the network. The distribution network may use fixed terrestrial or satellite links and may include further levels of MPEG-2 multiplexing, for example to provide regional programme variations. The synchronization requirements outlined in subclause 7.2 have to be kept in mind when designing the distribution network.

##### 7.1.2.1 Unequipped optical fibre ("Dark fibre")

Access to unequipped optical fibre (sometimes known as "dark fibre") is available in some countries depending on the regulatory regime and the network operators. If available it offers a convenient and economical method of distribution over distances up to about 100 km. The fibre is supplied without an optical source or receiver, or any other terminal or monitoring equipment; the user supplies suitable terminal equipment and makes a direct connection to the fibre, which is usually fitted with de-mountable connectors. For safety reasons, a maximum launch power is specified. Beyond this, the only restrictions on signal transmission - unless otherwise agreed - are determined by the user's terminal equipment and the optical properties of the fibre itself.

The use of bi-phase-mark channel code, as specified in DVB Professional Interface (DVB-PI) (see EN 50083-9 [8]), provides good transmission characteristics (no Direct Current (DC)-component and frequent data transitions), although doubling the apparent bit rate. Short distances up to about 3 km may use multi-mode fibre with a light-emitting diode or laser transmitter; longer distances have to use single-mode fibre with a laser transmitter. Laser transmitters are available at two wavelengths: 1 300 nm and 1 500 nm. At 1 300 nm the limit of transmission distance is set by the attenuation of the fibre; at 1 500 nm, where fibre attenuation is at its minimum, the limit is set by dispersion and will therefore depend on the spectral purity of the laser transmitter.

##### 7.1.2.2 PDH networks

Plesiochronous Digital Hierarchy (PDH) was designed for digitized signals based on 64 kbit/s. ITU-T Recommendation G.703 [12] specifies interfaces at various hierarchical levels; the interface at 34,368 Mbit/s is

suitable for the TS. An interface between DVB Transport Streams and PDH networks has been specified in ETS 300 813 [6].

### 7.1.2.3 SDH networks

Synchronous Digital Hierarchy (SDH) is a newer alternative to PDH using a simplified multiplexing and demultiplexing technique and offering improved network management capabilities. In Europe the network interface is at the STM-1 level of 155,520 Mbit/s. Equipment for adaptation of DVB MPEG-2-TS to SDH networks has been specified by DVB in ETS 300 814 [7].

### 7.1.2.4 ATM networks

In the future, networks using the Asynchronous Transfer Mode (ATM) may be offered for primary distribution. ATM uses a cell-based multiplexing technique and may be carried over different kinds of transport networks including PDH (see ETS 300 813 [6]) and SDH (see ETS 300 814 [7]). ATM cells consist of a 5-octet header followed by 48 payload octets. Five different ATM Adaptation Layers (AALs) have been specified for adapting different types of signal to ATM networks. AAL1 or AAL5 may be used for the transmission of an MPEG-2-TS; the main difference is that AAL1 specifies error detection and correction techniques, whereas AAL5 does not.

The network adapter specified by DVB for adaptation to PDH (see ETS 300 813 [6]) and SDH (see ETS 300 814 [7]) networks (see subclauses 7.1.2.2 and 7.1.2.3) is based on adaptation of the MPEG-2-TS into ATM cells using AAL1 and then adapts the ATM cells to PDH or SDH framing. Thus these specifications for interfacing to PDH (see ETS 300 813 [6]) and SDH (see ETS 300 814 [7]) networks can be used for adaptation to an ATM network.

### 7.1.2.5 Satellite distribution

The TS can be distributed by satellite using the DVB-S (see EN 300 421 [3]) specification (see subclause 4.2.2). However, a re-multiplexing operation will be required at each transmitter site to change the SI data to reflect the change of delivery medium.

## 7.2 Synchronization

### 7.2.1 MPEG timing aspects

The MPEG-2 decoder in the receiver has to regenerate the programme clock. It usually does this from samples of the programme clock (Programme Clock Reference - PCR) inserted in some of the MPEG packets - the specification requires a maximum interval between successive PCRs for each programme of 0,1 s. Any process that alters the original separation in time of successive PCRs without correcting them will cause jitter in the receiver's clock.

A multiplexing or re-multiplexing operation will insert a varying number of packets between the packets of any given service, thereby potentially altering the separation of the PCRs. Therefore in general any multiplexer has to re-stamp the PCRs at its output; this should ensure that decoder clock jitter remains within specification. The splitting of a Transport Stream into high priority and lower priority streams for hierarchical modulation has to be regarded as a re-multiplexing operation and so will generally require re-stamping of the PCRs.

In addition, each video service carries Presentation Time Stamps (PTS). These indicate the time at which a coded picture should be removed from the decoder buffer, decoded and displayed. This PTS is offset from the current time as indicated by the PCR by an amount depending on factors such as the size of the coder and decoder buffers and the bit-rate of the elementary stream. In a long chain of multiplexers, unless suitable steps are taken, it is possible for the packet to arrive after it should have been decoded - that is, the decoder buffer has underflowed.

There is a mechanism in MPEG for regulating this problem. There is provision for a "multiplex buffer utilization descriptor" that indicates what timing tolerance is available for buffering the signal. Each multiplexer could use this descriptor to decide which packets should have highest priority and would re-stamp it by subtracting the tolerance that had been used in that multiplexer's buffer. However, it is not certain whether present MPEG equipments implement this descriptor.

Another possibility is for the broadcaster to constrain the buffer occupancy of the coder to allow sufficient timing tolerance for the cumulative maximum expected delay through multiplexer buffers in the network. This will be difficult

in practice because broadcasters may not control all the coders producing their signals, nor all the multiplexers in their distribution chains.

In a regional network, drop-and-insert operations are required at regional centres to allow regional variations. Such operations can be made more easily if all MPEG coders and multiplexers are locked to a common frequency standard such as the 10 MHz reference from a frequency standard locked to GPS. In this case the same frequency standard may be used to lock the COFDM modulator as described in subclause 7.2.2(3). However, some MPEG-2 multiplexers cannot be locked to an external clock; in such cases one of the other methods of synchronization described in subclause 7.2.2 shall be used.

## 7.2.2 Synchronization of MPEG multiplexer and modulator

The bit-rate of the input MPEG-2-TS has to be constrained to that of the transmission mode chosen in the COFDM modulator. Four possible methods for synchronizing the MPEG multiplexer and the modulator have been implemented and demonstrated in practical trials.

The choice should take into account the characteristics of the actual network.

1. COFDM modulator is the master: In the simplest case, where the MPEG multiplexer producing the TS and the modulator are co-sited, synchronization can be assured by a demand clock from the modulator to the multiplexer. However, the multiplexer will normally be remote from the modulator; in this case there are three further possibilities for synchronization that can also be used to overcome any problems due to wander and jitter of primary distribution network clocks.
2. Both COFDM modulator and the multiplexer are masters: The modulator has a simple remultiplexer before its input which adapts the input TS bit-rate to the bit-rate available by inserting null packets; this operation would require restamping of the Programme Clock References (PCR) for each service as appropriate and as described in subclause 7.2.1. The usable input TS bit-rate has to be constrained to be less than the bit-rate deliverable by the modulator, but there is no need for synchronization between multiplexer and modulator. This method is completely flexible but is somewhat wasteful of bit-rate, more so if there are a number of remultiplexing nodes in the network upstream of the modulator. If the modulator is part of an SFN there has to be a unique stuffing and restamping unit serving all modulators of the SFN.
3. The multiplexer is master: The modulator has a large buffer memory at its input, the output clock of which is controlled by the degree of fullness of the buffer by a phase locked loop.
4. External master clock: Alternatively both modulator and multiplexer are synchronized to a universally available stable external clock such as the 10 MHz reference from a frequency locked to GPS, High precision standard frequency transmitter (77,5 MHz) in Germany (DCF77) or MSF. It has been shown experimentally to give perfect synchronization of a primary distribution network including a terrestrial ATM link concatenated with a satellite link with several remultiplexing operations.

The use of SFN techniques will impose more stringent requirements for synchronization in the primary distribution network (see clause 8).

## 7.3 Network control and monitoring

Because of the large number of options in the DVB-T (see EN 300 744 [5]) specification each piece of equipment in the programme chain will have a control input to change modes, bit-rates etc. All sites will therefore need to be linked by a control and monitoring network. Although programme interfaces have been standardized by DVB, control interfaces are not standardized and are therefore proprietary to each manufacturer. Integrating equipment from different manufacturers will therefore cause difficulty in interfacing to a single control and monitoring network.

---

# 8 SFN operation

## 8.1 Short recall on SFN exclusive features

- gap-filling possibilities;

- smaller frequency reuse distance;
- spectrum efficiency;
- the right power at the right place = power efficiency;
- smoother coverage;
- possibilities of tailoring/increasing the coverage area.

## 8.2 Different implementation possibilities

### 8.2.1 Re-amplification of the signal at the RF level

In this case, a unique COFDM encoder feeds the sole main transmitter that is responsible for transposing the signal to the right RF frequency. Each gap-filler then re-amplifies - on the same RF frequency - the on-air signal received from the main transmitter.

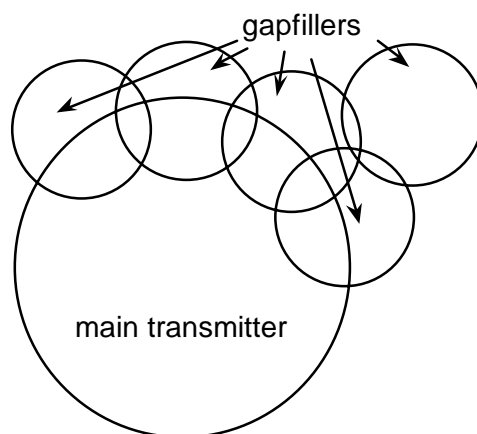

**Figure 11: Gap-fillers fed from main transmitter**

### 8.2.2 Analogue distribution of the COFDM signal

In this case, a unique COFDM encoder feeds all the transmitters; each transmitter is responsible for transposing the incoming signal to the right RF frequency.

### 8.2.3 Digital distribution of the MPEG stream

In this case, each transmitter is fed through a dedicated COFDM encoder and there is consequently a one-to-one correspondence between the set of transmitters and the set of encoders. This technique is the most complex one, but also the most powerful one. It can be used in combination with any of the two mentioned alternative techniques, or even with both of them.

Only this digital technique for distributing the MPEG signal to the whole set of Single Frequency transmitters will be considered and further explained.

## 8.3 SFN constraints

As noted above for the Single Frequency approach, it is necessary that the signal received from any transmitter looks like an echo of the signal received from any other transmitter: as a consequence, all the related broadcast signals have to be frequency, time and "bit" synchronized.

### 8.3.1 Frequency synchronization

The OFDM signal is made of a plurality of parallel carriers and **each** of these thousands of carriers have to be broadcast at the **same** RF frequency when it is broadcast by different transmitters working on an SFN basis. The needed frequency accuracy for this depends on the spacing of carriers, or in other words, on the frequency distance between two adjacent carriers, which is often referred to as the "carrier spacing" and noted  $\Delta f$ . If  $f_k$  denotes the ideal RF position of the  $k^{\text{th}}$  carrier, then each transmitter should broadcast this  $k^{\text{th}}$  carrier at  $f_k \pm (\Delta f / 1\ 000)$  - tolerance value to be confirmed by adequate field test.

To achieve this requirement, all the cascaded oscillators within each transmitter (from the baseband sampling frequency to the RF transposer, via the different IF stages) have to have a tolerance appropriate to keep the transmitted signal to the required accuracy. One way of doing this is for each oscillator to be driven by a reference oscillator, preferably accessible to all the different transmitting sites.

### 8.3.2 Time synchronization

In theory:

- COFDM systems have been designed to take benefit from echoes, as long as they enter the guard interval. This condition requires time synchronization of the various transmitters, since the same symbol has to be *emitted at the same instant* from several places, whatever the time delay introduced by the distribution network. The needed time accuracy for this is not very high, because of the intrinsic tolerance brought by the guard interval duration, which is often noted  $\Delta T$ . However, since the guard interval should be used to make up for the terrestrial channel time delay spread and not to compensate inaccurate network time synchronization, an accuracy of  $\pm 1\ \mu\text{s}$  seems a good basis.

In practice:

When echoes exceed the guard interval duration, the performances rapidly decrease for two reasons:

- 1) the orthogonality principle gets violated because of intersymbol interference. This results in a BER increase, that will be more severe as the data rate is higher: 64-QAM modes for instance will suffer from this problem more rapidly than QPSK ones.
- 2) the channel estimation is not able to correctly assess echoes longer than about a fourth of the symbol useful duration  $T_U$ . Although this might depend on each receiver design, it is worth remembering that the mode  $\Delta T = T_U / 4$  is consequently expected to be less rugged than others with respect to the issue of echoes exceeding the guard interval duration.

As a consequence of echoes management within a COFDM receiver, the actual coverage area produced by a set of SFN transmitters strongly depends on the performance of the time synchronization subsystem. A deliberate time offset at a given node of the network may in some cases allow for a fine adjustment of the coverage area, or for a greater smoothness of the available Carrier to Noise Ratio (C/N).

### 8.3.3 Bit level synchronization

Emitting the same symbol at the same time demands that all carriers be identically modulated. Consequently, the same bits have to modulate the same  $k^{\text{th}}$  carrier. The tolerance to this rule is zero.

### 8.3.4 Energy dispersal synchronization

In order to ensure adequate binary transitions, the data of the MPEG-2-TS are randomized as soon as they enter the modulator. This is done through the binary addition of the incoming stream with a standardized PRBS which is reset every eight MPEG-2 packet. For the randomized stream to be absolutely identical in all the modulators, each PRBS generator is reset by a deterministic mechanism.

## 8.4 Network constraints

### 8.4.1 Cable/satellite/terrestrial commonalties

To ensure the reusability of those network adapters that have been previously developed to feed the cable and satellite head-ends, the signal issued from the MUX to feed the parallel transmitters has to be MPEG-2-TS / DVB-PI (see EN 50083-9 [8]) compliant.

### 8.4.2 Maximum time spread in the network

The *maximum time spread* introduced by the distribution network is the difference between the time needed by the signal to go from the MUX through the network to the nearest transmission site on the one hand and the time needed by the same signal to go from the same MUX through other branches of the network to the furthest site on the other hand. It strongly depends on the chosen technology for this network; the longest time spread are probably reached in hybrid networks, in which some transmitters are fed using one technology (e.g. fibre optics) whilst other sites are fed using another technology (e.g. satellite links). However, it is very unlikely that this transit time difference would exceed one second.

### 8.4.3 Transit times stability

The transit time of a message within a given branch of a network is not necessarily constant: a stationary satellite is never absolutely stable for example and oscillates on the contrary within a cube of about 75 km<sup>3</sup> over a period of one month. The time duration of the satellite link therefore varies by  $\pm 250 \mu\text{s}$ , which is much higher than the tolerance.

The network time synchronization mechanism consequently needs to be tolerant with regards to the transit time instability.

### 8.4.4 Possible candidates for absolute time reference

In an SFN network, each modulator is fed from the multiplexer through a distribution network, which introduces a time delay that varies from one transmitting site to the other. Consequently, no time reference can be given to the transmitters from the multiplexer. There is a need for an external absolute time provider, able to offer to each site a time value with an accuracy better than 1  $\mu\text{s}$ .

GPS seems to be an excellent candidate for that purpose. Suitable GPS receivers provide both a frequency reference (10 MHz) and a phase reference of absolute time.

### 8.4.5 Remote control of distributed transmitters

The DVB-T (see EN 300 744 [5]) standard allows for more than one hundred different configurations of the modulator: in a SFN environment, it might become difficult, given these conditions, to ensure that all the parallel encoders are coherently configured. The simplest way to cope with this problem seems to remotely control (e.g. using ad-hoc data embedded in some MPEG packets) these encoders from the unique MUX site.

## 8.5 The mega-frame solution

### 8.5.1 Why a mega-frame is necessary

Whatever DVB-T mode, a DVB-T frame is always made of 68 OFDM symbols. With the 8k mode, 68 symbols always carry an integer number of Reed-Solomon encoded MPEG-2 packets, whatever the chosen constellation or inner code rate. Unfortunately, this is no more the case with the 2k mode, hence the superframe concept: a superframe is a set of 4 successive frames (whatever the FFT size) so that the above condition becomes true within a superframe for both 2k-mode and 8k-mode.

However, in defining the MPEG-2 TS that will feed the parallel channel encoders of an SFN, we still need to define the extra concept of a mega-frame to guarantee that the PRBS generators that are in charge of energy dispersal within each channel encoder, are all reset in the same time synchronized and deterministic way.

## 8.5.2 The Mega-frame solution

Figure 12 shows a block diagram of a complete SFN system.

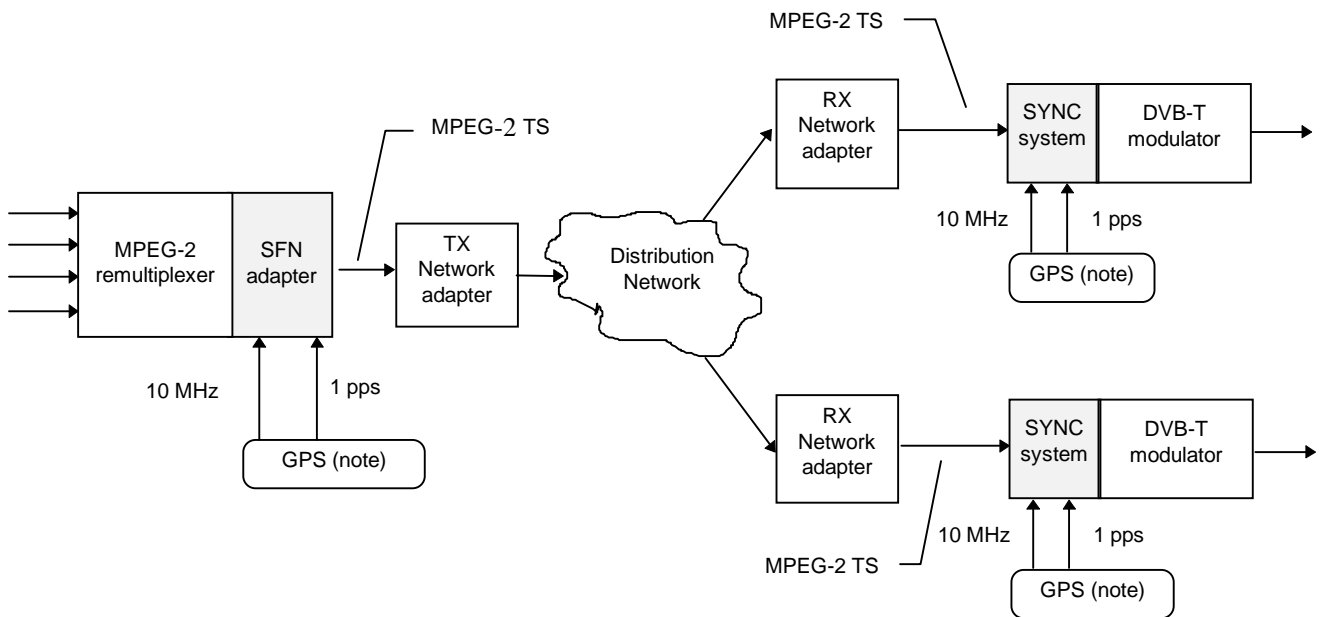

NOTE: Could be any common available frequency reference.

**Figure 12: DVB-T primary distribution with SFN adaptation**

The SFN functionality is an extension to the DVB system. The blocks associated with SFN functionality are the grey boxes in figure 12. These blocks could be implemented either as separate equipment or integrated in the multiplexer and/or the DVB-T modulator.

### SFN system blocks:

#### MPEG-2 re-multiplexer

The MPEG-2 re-multiplexer re-multiplexes the programmes from various input channels, updates the SI and provides an MPEG-2 TS which, after SFN adaptation, is transmitted via the DVB-T modulators in the SFN.

#### SFN adapter

The SFN adapter forms a mega-frame, consisting of  $n$  TS-packets corresponding to 8 DVB-T frames in the 8k mode or 32 frames in the 2k mode, and inserts a Mega-frame Initialization Packet (MIP) with a dedicated PID value. Inserted anywhere within a mega-frame of index  $M$ , the MIP of that mega-frame,  $MIP_M$ , allows to uniquely identify the starting point (i.e. the first packet) of the mega-frame  $M+1$ . This is accomplished by using a pointer carried by the  $MIP_M$  itself to indicate its position with regards to the start of the mega-frame  $M+1$ .

The time difference between the latest pulse of the "one-pulse-per-second" reference, derived e.g. from GPS, that precedes the start of the mega-frame  $M+1$  and the actual start (i.e. first bit of first packet) of this mega-frame  $M+1$  is copied into the  $MIP_M$ . This parameter is called Synchronization Time Stamp (STS).

The time duration of a mega-frame is independent of the duration  $T_u$ , constellation and code rate of the DVB-T signal. Four different time durations exist depending on the chosen guard interval proportion:

- 0,502656 s ( $\Delta/T_u = 1/32$ );
- 0,517888 s ( $\Delta/T_u = 1/16$ );
- 0,548352 s ( $\Delta/T_u = 1/8$ );
- 0,609280 s ( $\Delta/T_u = 1/4$ ).



The output of the SFN adapter shall be fully DVB/MPEG-2 TS compliant.

#### TX/RX network adapter

The network adapters shall provide a transparent link for the MPEG-2 TS from the central to the local units. The maximum network delay (caused by the different paths of the transmission network) the SYNC system can handle is 1 second.

#### SYNC system

The SYNC system will provide a propagation time compensation by comparing the inserted STS with the local time reference and calculate the extra delay needed for SFN synchronization.

#### DVB-T modulator

The modulator should provide a fixed delay from the input to the air interface. The information inserted in the MIP could be used for the direct control of the modulator modes or control of other transmitter parameters. The modulator clocks at the different sites have to be synchronized. Since it is a requirement of an SFN that all transmitted signals be identical, the MPEG-2 TS inputs to the various DVB-T modulators have to be bit identical.

#### GPS

GPS is one among many possible time references but it is the only one available globally. GPS receivers are available which provide both a 10 MHz frequency reference and a 1 pulse per second (1 pps) time reference. The 1 pps time reference, used in SFN synchronization, is divided into 100 ns steps of the 10 MHz clock. The 10 MHz system clock is assumed to be available at all nodes in the network.

### 8.5.3 Mega-frame definition

The output of the SFN adapter shall be a valid MPEG-2 Transport Stream, where the individual packets are organized in groups, which constitute a mega-frame. Each mega-frame consists of n packets, where n is an integer number which depends on the number of RS-packets per superframe in the DVB-T mode that will be used for DVB-T emission of the MPEG-2 TS (see ETS 300 744 [5], subclause 4.7: "Number of RS-packets per OFDM superframe"). In the 8k mode n is (the number of RS-packets per superframe)  $\times$  2. In the 2k mode n is (the number of RS-packets per superframe)  $\times$  8.

Each mega-frame contains exactly one Mega-frame Initialization Packet. The actual position may vary in an arbitrary way from mega-frame to mega-frame. The pointer value in the MIP is used to indicate the start of the following mega-frame. In figure 13 the overall structure of the mega-frame, including the positioning of the MIP, is given.

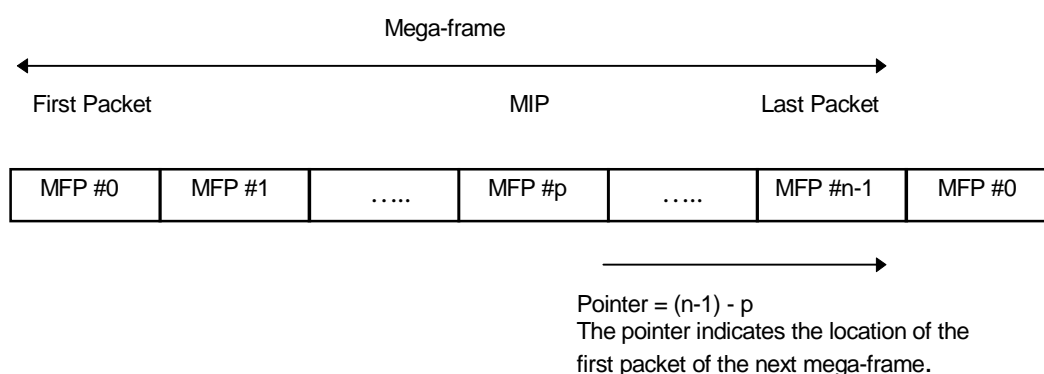

**Figure 13: Overall mega-frame structure**

The start of a mega-frame in the DVB-T signal is defined to coincide with the beginning of a DVB-T superframe and the start of an inverted sync byte, being part of transport multiplex adaptation.

## 8.5.4 MIP format

The MIP is an MPEG-2 compliant 188 byte TS packet, organized as shown in table 1 of document *Specification of a mega-frame for SFN synchronization* (ETSI TS 101 191 [13]). Although it is carried in mega-frame of index  $M$ , the MIP always refers to the following mega-frame  $M + 1$ , except for the *tps-mip* field, that refers to mega-frame  $M + 2$ .

Some of the TPS data, although already included in the SI tables, will be inserted by the MUX in the *tps-mip* field of the MIP of index  $M$ , in order to simplify the (necessarily identical) remote programming of all the distributed channel encoders, in terms of FFT size, constellation, code rates and guard interval proportion.

Within the MIP it is also possible to include configuration data for individual transmitters with regard to deliberate time offset (relative to what is determined by "STS" + "Maximum delay"), deliberate frequency offset (relative to the centre frequency of the UHF channel) and ERP. It is also possible to define private data. All this data can be addressed to individual transmitters so that each transmitter in the network uses a unique configuration.

## 8.5.5 A possible implementation

To provide an absolute time reference on the MUX site and on all the different transmitting sites, the following mechanism can be used:

Each site will host a 24-bit counter, that will be incremented by the GPS 10 MHz reference clock and reset on every second of the universal absolute time by the GPS pulse marker.

To sign the emission date of the following mega-frame  $M + 1$ , the MUX will copy into the 3-byte *synchronization\_time\_stamp* field of the MIP packet contained in the mega-frame of index  $M$  the value that will be reached by its own counter when it will emit the first bit of the first packet of the mega-frame  $M + 1$ . An offset value, entered by the human operator of the distribution network, is then inserted by the MUX in the 3-byte field *maximum\_delay*. This "offset" field shall be greater than the maximum delay spread introduced by the network and is expressed as a certain number of 100 ns long (1/10 MHz) periods.

Due to its a priori knowledge of the PID of the MIP, each channel encoder will extract the MIP from each mega-frame  $M$  of the incoming MPEG-TS, add both time fields *synchronization\_time\_stamp* + *maximum\_delay* (modulo 1s) and wait for its local counter to reach the resulting value before emitting the associated following mega-frame  $M + 1$ . The instant for "emitting the associated following mega-frame" shall be understood as the instant at which the first sample of the guard interval of the COFDM symbol that carries the first packet of the mega-frame just leaves the transmitting antenna. It is up to each channel encoder to take into account the transit delay brought by the digital and analogue processes through the channel encoder itself and then through the power amplification stages.

## 8.6 Hierarchical modes particularities

### 8.6.1 Multiple channels network adapters

Network adapters have been developed that offer more than one single MPEG stream input. Such devices are particularly well suited in an hierarchical context (figure 14).

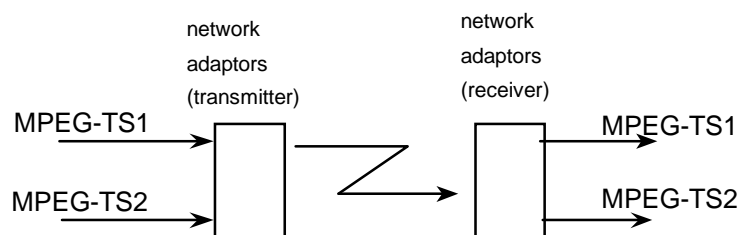

Figure 14: Distribution of 2 MPEG transport streams

## 8.6.2 HP/LP time synchronization

Both HP and LP MPEG-TS streams will probably be issued from two different multiplexers and accordingly sent separately through the distribution network. Although rather unlikely, they may even use different distribution networks.

The problem is to synchronize both HP and LP signals, because the COFDM signal is frame driven and the concept of frame is unique also in the hierarchical mode.

*If the two multiplexers are close to each other (say in the same room):*

The two multiplexers should be linked and time synchronized so that both transport streams get the same *STS* value in their respective MIP. Also the *maximum\_delay* fields within the MIPs need to be identical. Under these conditions, the channel encoder will be able to broadcast both HP and LP mega-frames at the same instant, wherever the channel encoder is located.

*If the two multiplexers are NOT close to each other, the time synchronization is more difficult.*

However, even if both MUX1 and MUX2 have shifted mega-frames starting points, they already are frequency locked. Consequently and whatever the channel encoder, HP and LP streams are time shifted the same way everywhere once they are ready to enter the external coding process: for example, the HP stream is systematically 100 ms ahead of the LP stream. A possible solution is to require every channel encoder to resynchronize both streams by choosing one of these streams as a time reference. Each channel encoder will thus be in a position to suitably delay the other one in such a way that both mega-frames become synchronized.

---

# 9 Network planning

Work towards the establishing of planning parameters has been going on for some time in EBU. This work has involved a long-standing co-operation with the digital Terrestrial Television broadcasting (dTTb) project and a more recent one with the project Validate.

Clause 9 of the present document is taken from relevant parts of the EBU planning document BPN 005 [14] second issue July 1997 and CEPT Multilateral Coordination Agreement, Chester, July 1997 [15].

For the convenience of the reader the tables from EBU document BPN 005 [14] have been copied to this document.

Assumptions on receiver noise figures and implementation margin are those assumed in the EBU document BPN 005 [14]. The tables are based on a noise figure of 7 dB. A figure for implementation margin (3 dB) is considered by the ACTS project DVB Integrated Receiver Decoder (ACTS project AC 108) (DVBIRD) to be valid. This figure has to be added to the *C/N* values in figure 4 to achieve the *C/N* values used in the following tables.

## 9.1 Coverage definitions for fixed and portable reception

### 9.1.1 Introduction

It is necessary to have definitions for the coverage of a terrestrial TV transmitting station or a group of such stations. Such definitions may be based primarily on technical criteria but need to be readily usable for non-technical purposes.

The above is true for analogue TV transmissions as well as for digital ones. However, the case of analogue stations is relatively easy to deal with as the line defining any edge of a coverage area is rather "soft" and it is not necessary to be too precise about where the line actually lies in any given area; indeed in many cases it is not really possible to be precise.

Digital TV service coverage is characterized by a very rapid transition from near perfect reception to no reception at all and it thus becomes much more critical to be able to define which areas are going to be covered and which are not. However, because of the very rapid transition described above, there is a cost penalty if the coverage target within a small area (e.g. 100 m × 100 m) is set too high. This occurs because it is necessary either to increase the transmitter

powers or to provide a larger number of transmitters in order to guarantee coverage to the last few percent of the worst-served small areas.

It should be borne in mind that in a given situation it may be possible to improve reception:

- by finding a better position for the antenna;
- by using a (more) directional antenna with a higher gain;
- by using a low-noise antenna amplifier (in the case of fixed antenna reception).

### 9.1.2 Fixed antenna reception

Fixed antenna reception is defined as:

- Reception where a directional receiving antenna mounted at roof level is used.

In calculating the equivalent field strength required for fixed antenna reception, a receiving antenna height of 10 m above ground level is considered to be representative. In the case of fixed antenna reception it is assumed that near-optimal reception conditions (for the relevant RF channels) are found when the antenna is installed.

### 9.1.3 Portable antenna reception

Portable antenna reception is defined as:

Class A (outdoor) being reception where a portable receiver with an attached or built-in antenna is used:

- outdoors at no less than 1,5 m above ground level;

Class B (ground floor indoor) being reception where a portable receiver with an attached or built-in antenna is used:

- indoors at no less than 1,5 m above floor level in rooms;
- on the ground floor;
- with a window in an external wall.

Portable antenna reception will, in practice, take place under a great variety of conditions (outdoor, indoor, ground floor, first floor, upper floors). It could even be envisaged that a portable receiver is moved while being viewed.

It is to be expected that there will be significant variation of reception conditions for indoor portable reception, depending to some extent, on the floor-level at which reception is required. However, there will also be considerable variation of building penetration loss from one building to another and also considerable variation from one part of a room to another. Some estimates of the probable signal level requirements for different floor-levels are given in subclause 9.2.

In both classes, A and B, it is assumed that the portable receiver is not moved during reception and large objects near the receiver are also not moved. It is also assumed that extreme cases, such as reception in completely shielded rooms, are disregarded.

It is to be expected that portable coverage is mainly aimed at urban areas. In many countries most people living in urban areas live in apartment buildings. The second category, class B, is therefore probably the more common case of portable reception. It is to be expected that reception will be less difficult in rooms higher than the ground floor.

## 9.1.4 Coverage area

In defining the coverage area for each reception condition, a three level approach is taken:

Receiving location

- The smallest unit is a receiving location with dimensions of about 0,5 m × 0,5 m. In the case of portable antenna reception, it is assumed that optimal receiving conditions will be found by moving the antenna within 0,5 m in any direction. In the case of fixed antenna reception, it is assumed that near-optimal reception conditions are found when the antenna is installed.
- Such a location is regarded as covered if the required carrier-to-noise and carrier-to-interference values are achieved for 99 % of the time.
- Small area coverage.
- The second level is a "small area" (typically 100 m × 100 m).
- In this small area the percentage of covered location is indicated.
- The coverage of a small area is classified as:
  - "Good", if at least 95 % of receiving locations within it are covered;
  - "Acceptable", if at least 70 % of locations within it are covered;

Coverage area.

- The third level is the coverage area.
- The coverage area of a transmitter, or a group of transmitters, is made up of the sum of the individual small areas in which a given class of coverage is achieved.

## 9.1.5 Examples of practical usage

In the case where simplified definitions of transmitter coverage are required, a phrase such as "area within which good fixed antenna reception is expected" is equivalent to:

- coverage area for a transmitter;
- at least 95 % of receiving locations within every included small area are covered;
- fixed antenna reception.

In the same way "an area within which acceptable class B portable antenna reception, is expected" is equivalent to;

- coverage area for a transmitter;
- at least 70 % of indoor ground floor receiving locations within every included small area are covered;
- portable antenna reception.

## 9.2 Minimum field strength considerations

### 9.2.1 Minimum receiver signal input levels

To illustrate how the C/N ratio influences the minimum signal input level to the receiver, the latter has been calculated for five representative C/N ratios in the range 2 dB to 26 dB. For other values simple linear interpolation can be applied.

The receiver noise figure has been chosen as 7 dB for all the frequency bands I to V and thus the minimum receiver input signal level is independent of the transmitter frequency. If other noise figures are used in practice, the minimum receiver input signal level will change correspondingly by the same amount.

The minimum receiver input signal levels calculated here are used in subclause 9.2.2 to derive the minimum power flux densities and corresponding minimum median equivalent field strength values for various frequency bands.

**Definitions:**

- B : Receiver noise bandwidth (Hz)  
 F : Receiver noise figure (dB)  
 $P_n$  : Receiver noise input power (dBW)  
 C/N : RF signal to noise ratio required by the system (dB)  
 $P_{s\ min}$  : Minimum receiver signal input power (dBW)  
 $Z_i$  : Receiver input impedance (75Ω)  
 $U_{s\ min}$  : Minimum equivalent receiver input voltage into  $Z_i$  (dBμV)

**Constants:**

- k : Boltzmann's constant =  $1,38 \times 10^{-23}$  Ws/K  
 $T_0$  : absolute Temperature = 290 K

**Formulae used:**

$$P_n = F + 10 \log (k \times T_0 \times B)$$

$$P_{s\ min} = P_n + C/N$$

$$U_{s\ min} = P_{s\ min} + 120 + 10 \log (Z_i)$$

**Table 3: Minimum equivalent input signal level to receiver**

Frequency Band I, III, IV, V						
Equivalent noise band width	B (Hz)	$7,6 \times 10^6$	$7,6 \times 10^6$	$7,6 \times 10^6$	$7,6 \times 10^6$	$7,6 \times 10^6$
Receiver noise figure	F (dB)	7	7	7	7	7
Receiver noise input power	$P_n$ (dBW)	-128,2	-128,2	-128,2	-128,2	-128,2
<b>RF signal/noise ratio</b>	<b>C/N (dB)</b>	<b>2</b>	<b>8</b>	<b>14</b>	<b>20</b>	<b>26</b>
Min. receiver signal input power	$P_{s\ min}$ (dBW)	-126,2	-120,2	-114,2	-108,2	-102,2
Min. equivalent receiver input voltage, 75 Ω	$U_{s\ min}$ (dBμV)	13	19	25	31	37

NOTE: Table 3 provides a derivation of minimum required signal levels. Subclauses 9.2.2.2 and 9.2.2.3 provide information on the **minimum median** values of signal levels required in practical situations.

## 9.2.2 Signals levels for planning

### 9.2.2.1 General

In subclause 9.2.1 the minimum signal levels to overcome noise are given as the minimum receiver input power and the corresponding minimum equivalent receiver input voltage. No account is taken of any propagation effects. However, it is necessary to take account of these effects when considering TV reception in a practical environment.

In defining coverage it is indicated that due to the very rapid transition from near perfect to no reception at all, it is necessary that the minimum required signal level is achieved at a high percentage of locations. These percentages have been set at 95 for "good" and 70 for "acceptable" reception.

The minimum median power flux densities are calculated for:

- a) Three different receiving conditions:
  - 1) Fixed antenna reception;
  - 2) Portable outdoor reception;
  - 3) Portable indoor reception at ground floor.
- b) Four frequencies representing Band I, Band III, Band IV and Band V:
  - 1) 65 MHz;
  - 2) 200 MHz;
  - 3) 500 MHz;
  - 4) 800 MHz.
- c) Five representative C/N ratios in the range 2 dB to 26 dB in steps of 6 dB.

Representative C/N values are used for these examples. Results for any chosen system variant may be obtained by interpolation between relevant representative values.

**All minimum median equivalent field strength values presented in this chapter are for coverage by a single transmitter only, not for Single Frequency Networks.**

To calculate the minimum median power flux density or equivalent field strength needed to ensure that the minimum values of signal level can be achieved at the required percentage of locations, the following formulae are used:

$$\phi_{\min} = P_{s \min} - A_a + L_f \quad (\text{in tables 5 to 8})$$

$$\phi_{\min} = P_{s \min} - A_a \quad (\text{in tables 10 to 17})$$

$$E_{\min} = \phi_{\min} + 120 + 10 \log (120\pi) = \phi_{\min} + 145,8$$

$$\phi_{\text{med}} = \phi_{\min} + P_{\text{mmn}} + C_1 \quad (\text{in tables 5 to 8})$$

$$\phi_{\text{med}} = \phi_{\min} + P_{\text{mmn}} + C_1 + L_h \quad (\text{in tables 10 to 13})$$

$$\phi_{\text{med}} = \phi_{\min} + P_{\text{mmn}} + C_1 + L_h + L_b \quad (\text{in tables 14 to 17})$$

$$E_{\text{med}} = \phi_{\text{med}} + 120 + 10 \log (120\pi) = \phi_{\text{med}} + 145,8$$

C/N : RF signal to noise ratio required by the system (dB)

$\phi_{\min}$  : Minimum power flux density at receiving place (dBW/m<sup>2</sup>)

$E_{\min}$  : Equivalent minimum field strength at receiving place (dB $\mu$ V/m)

$L_f$  : Feeder loss (dB)

$L_h$  : Height loss (10 m a.g.l. to 1,5 m. a.g.l.) (dB)

$L_b$  : Building penetration loss (dB)

$P_{\text{mmn}}$  : Allowance for man made noise (dB)

$C_1$  : Location correction factor (dB)

$\phi_{\text{med}}$  : Minimum median power flux density, planning value (dBW/m<sup>2</sup>)

$E_{\text{med}}$  : Minimum median equivalent field strength, planning value (dB $\mu$ V/m)

For calculating the location correction factor  $C_1$  a log-normal distribution of the received signal is assumed.

NOTE: This standard deviation only relates to location statistics and the inherent inaccuracies of the propagation prediction method are not taken into account.

The location correction factor will need to be re-assessed as more information becomes available.

The location correction factor can be calculated by the formula:

$$C_1 = \mu \times \sigma$$

where:

$\mu$  is the distribution factor, being 0,52 for 70 % and 1,64 for 95 %;

$\sigma$  is the standard deviation taken as 5,5 dB for outdoor reception.

See subclause 9.2.2.2 for  $\sigma$  values appropriate for indoor reception.

While the matters dealt with in this chapter are generally applicable, additional special considerations are needed in the case of SFNs where there is more than one wanted signal contribution.

## 9.2.2.2 Fixed antenna reception

### 9.2.2.2.1 Antenna directivity and gain

The antenna diagrams (directivity) to be used for DVB-T planning are given in ITU-R Recommendation 419 [16].

The antenna gains used in the derivation of the minimum median wanted signal levels given in table 4.

**Table 4: Antenna gain used in the derivation of the minimum median wanted signal levels**

65 MHz	200 MHz	500 MHz	800 MHz
3 dB	7 dB	10 dB	12 dB

These values are considered as realistic minimum values.

Within any frequency band, the variation of antenna gain with frequency may be taken into account by the addition of a correction term:

$$\text{Corr} = 10 \log (F_A/F_R)$$

where:

$F_A$  is the actual frequency being considered;

$F_R$  is the relevant reference frequency quoted above.

### 9.2.2.2.2 Minimum median power flux density and equivalent field strength

The tables below give the minimum median power flux density and the equivalent minimum median field strength for 70 % and 95 % of location probability in Band I, III, IV and V. These values are related to the minimum power flux density and minimum equivalent field strength at the receiving location. For Bands I and III an allowance for man-made noise has been included.



**Table 5: Minimum median power flux density and equivalent minimum median field strength in Band I for 70 % and 95 % location probability**

**Receiving condition: Fixed antenna, Band I**

Frequency Minimum C/N required by system	f (MHz) (dB)	65				
		2	8	14	20	26
Min. receiver signal input power	$P_{s \text{ min}}$ (dBW)	-126,2	-120,2	-114,2	-110,2	-102,2
Min. equivalent receiver input voltage, 75 $\Omega$	$U_{s \text{ min}}$ (dB $\mu$ V)	13	19	25	31	37
Feeder loss	$L_f$ (dB)	1				
Antenna gain relative to half wave dipole	$G_a$ (dB)	3				
Effective antenna aperture	$A_a$ (dBm <sup>2</sup> )	7,4				
Min power flux density at receiving place	$\phi_{\text{min}}$ (dBW/m <sup>2</sup> )	-132,7	-126,7	-120,7	-114,7	-108,7
Min equivalent field strength at receiving place	$E_{\text{min}}$ (dB $\mu$ V/m)	13	19	25	31	37
Allowance for man made noise	$P_{\text{mmn}}$ (dB)	6				
<b>Location probability: 70 %</b>						
Location correction factor	$C_l$ (dB)	2,9				
Minimum median power flux density at 10 m a.g.l. 50 % of time and 50 % of locations	$\phi_{\text{med}}$ (dBW/m <sup>2</sup> )	-123,8	-117,8	-111,8	-105,8	-99,8
Minimum median equivalent field strength at 10 m a.g.l. 50 % of time and 50 % of locations	$E_{\text{med}}$ (dB $\mu$ V/m)	22	28	34	40	46
<b>Location probability: 95 %</b>						
Location correction factor	$C_l$ (dB)	9				
Minimum median power flux density at 10 m a.g.l. 50 % of time and 50 % of locations	$\phi_{\text{med}}$ (dBW/m <sup>2</sup> )	-117,7	-111,7	-105,7	-99,7	-93,7
Minimum median equivalent field strength at 10 m a.g.l. 50 % of time and 50 % of locations	$E_{\text{med}}$ (dB $\mu$ V/m)	28	34	40	46	52

**Table 6: Minimum median power flux density and equivalent minimum median field strength in Band III for 70 % and 95 % location probability**

**Receiving condition: Fixed antenna, Band III**

Frequency Minimum C/N required by system	f (MHz) (dB)	200				
		2	8	14	20	26
Min. receiver signal input power	$P_{s \min}$ (dBW)	-126,2	-120,2	-114,2	-108,2	-102,2
Min. equivalent receiver input voltage, 75 $\Omega$	$U_{s \min}$ (dB $\mu$ V)	13	19	25	31	37
Feeder loss	$L_f$ (dB)	2				
Antenna gain relative to half wave dipole	$G_a$ (dB)	7				
Effective antenna aperture	$A_a$ (dBm <sup>2</sup> )	1.7				
Min power flux density at receiving place	$\phi_{\min}$ (dBW/m <sup>2</sup> )	-125,9	-119,9	-113,9	-107,9	-101,9
Min equivalent field strength at receiving place	$E_{\min}$ (dB $\mu$ V/m)	20	26	32	38	44
Allowance for man made noise	$P_{mmn}$ (dB)	1				
<b>Location probability: 70 %</b>						
Location correction factor	$C_l$ (dB)	2,9				
Minimum median power flux density at 10 m a.g.l. 50 % of time and 50 % of locations	$\phi_{\text{med}}$ (dBW/m <sup>2</sup> )	-122	-116	-110	-104	-98
Minimum median equivalent field strength at 10 m a.g.l. 50 % of time and 50 % of locations	$E_{\text{med}}$ (dB $\mu$ V/m)	24	30	36	42	48
<b>Location probability: 95 %</b>						
Location correction factor	$C_l$ (dB)	9				
Minimum median power flux density at 10 m a.g.l. 50 % of time and 50 % of locations	$\phi_{\text{med}}$ (dBW/m <sup>2</sup> )	-117,9	-111,9	-105,9	-99,9	-93,9
Minimum median equivalent field strength at 10 m a.g.l. 50 % of time and 50 % of locations	$E_{\text{med}}$ (dB $\mu$ V/m)	30	36	42	48	54

**Table 7: Minimum median power flux density and equivalent minimum median field strength in Band IV for 70 % and 95 % location probability**

**Receiving condition: Fixed antenna, Band IV**

Frequency Minimum C/N required by system	f (MHz) (dB)	500				
		2	8	14	20	26
Min. receiver signal input power	$P_{s \text{ min}}$ (dBW)	-126,2	-120,2	-114,2	-108,2	-102,2
Min. equivalent receiver input voltage, 75 $\Omega$	$U_{s \text{ min}}$ (dB $\mu$ V)	13	19	25	31	37
Feeder loss	$L_f$ (dB)	3				
Antenna gain relative to half wave dipole	$G_a$ (dB)	10				
Effective antenna aperture	$A_a$ (dBm <sup>2</sup> )	-3,3				
Min power flux density at receiving place	$\phi_{\text{min}}$ (dBW/m <sup>2</sup> )	-119,9	-113,9	-107,9	-101,9	-95,9
Min equivalent field strength at receiving place	$E_{\text{min}}$ (dB $\mu$ V/m)	26	32	38	44	50
Allowance for man made noise	$P_{\text{mmn}}$ (dB)	0				
<b>Location probability: 70 %</b>						
Location correction factor	$C_1$ (dB)	2,9				
Minimum median power flux density at 10 m a.g.l. 50 % of time and 50 % of locations	$\phi_{\text{med}}$ (dBW/m <sup>2</sup> )	-117	-111	-105	-99	-93
Minimum median equivalent field strength at 10 m a.g.l. 50 % of time and 50 % of locations	$E_{\text{med}}$ (dB $\mu$ V/m)	29	35	41	47	53
<b>Location probability: 95 %</b>						
Location correction factor	$C_1$ (dB)	9				
Minimum median power flux density at 10 m a.g.l. 50 % of time and 50 % of locations	$\phi_{\text{med}}$ (dBW/m <sup>2</sup> )	-110,9	-104,9	-98,9	-92,9	-86,9
Minimum median equivalent field strength at 10 m a.g.l. 50 % of time and 50 % of locations	$E_{\text{med}}$ (dB $\mu$ V/m)	35	41	47	53	59

**Table 8: Minimum median power flux density and equivalent minimum median field strength in Band V for 70 % and 95 % location probability**

**Receiving condition: Fixed antenna, Band V**

Frequency Minimum C/N required by system	f (MHz) (dB)	800				
		2	8	14	20	26
Min. receiver signal input power	$P_{s \min}$ (dBW)	-126,2	-120,2	-114,2	-108,2	-102,2
Min. equivalent receiver input voltage, 75 $\Omega$	$U_{s \min}$ (dB $\mu$ V)	13	19	25	31	37
Feeder loss	$L_f$ (dB)	5				
Antenna gain relative to half wave dipole	$G_a$ (dB)	12				
Effective antenna aperture	$A_a$ (dBm <sup>2</sup> )	-5,4				
Min power flux density at receiving place	$\phi_{\min}$ (dBW/m <sup>2</sup> )	-115,9	-109,9	-103,9	-97,9	-91,9
Min equivalent field strength at receiving place	$E_{\min}$ (dB $\mu$ V/m)	30	36	42	48	54
Allowance for man made noise	$P_{mmn}$ (dB)	0				
<b>Location probability: 70 %</b>						
Location correction factor	$C_l$ (dB)	2,9				
Minimum median power flux density at 10 m a.g.l. 50 % of time and 50 % of locations	$\phi_{\text{med}}$ (dBW/m <sup>2</sup> )	-113	-107	-101	-95	-89
Minimum median equivalent field strength at 10 m a.g.l. 50 % of time and 50 % of locations	$E_{\text{med}}$ (dB $\mu$ V/m)	33	39	45	51	57
<b>Location probability: 95 %</b>						
Location correction factor	$C_l$ (dB)	9				
Minimum median power flux density at 10 m a.g.l. 50 % of time and 50 % of locations	$\phi_{\text{med}}$ (dBW/m <sup>2</sup> )	-106,9	-100,9	-94,9	-88,9	-82,9
Minimum median equivalent field strength at 10 m a.g.l. 50 % of time and 50 % of locations	$E_{\text{med}}$ (dB $\mu$ V/m)	39	45	51	57	63

### 9.2.2.3 Portable antenna reception

#### 9.2.2.3.1 General

In general, most coverage studies concerning digital terrestrial TV have been aimed towards fixed reception using roof-level directional receiving antennas. However the possibility of outdoor or indoor reception on a portable receiver with an in-built or set-top receiving antenna might offer substantial additional user benefits. Portable reception will take place under a great variety of conditions e.g. outdoor, indoor, ground-floor or higher-floors and with simple antennas.

The conditions for portable reception differ from fixed reception in the:

- absence of receiving antenna gain and directivity;
- reduced feeder loss;
- generally lower reception height;
- building penetration loss in the case of indoor reception.

Portable antenna reception has been defined (see subclause 9.1.3) for class A (outdoor) and class B (indoor ground floor) cases.

As for fixed reception, "good" and "acceptable" coverages are defined as 95 % and 70 % covered locations.

The variation factors will be calculated in a similar way to that indicated in subclause 9.2.2.1.

### 9.2.2.3.2 Criteria for portable reception of digital TV

#### (i) Signal level variations

##### (i.1) General

Field strength variations can be divided into macro-scale and micro-scale variations. The macro-scale variations relate to areas with linear dimensions of 10 m to 100 m or more and are mainly caused by shadowing and multi-path reflections from distant objects. The micro-scale variations relate to areas with dimensions in the order of a wavelength and are mainly caused by multi-path reflections from nearby objects. As it may be assumed that for portable reception the position of the antenna can be optimized within the order of a wavelength, micro-scale variations will not be too significant for planning purposes. Another way to overcome these variations is the possibility of a receiver using antenna diversity.

Macro-scale variations of the field strength are very important for coverage assessment. In general, a high target percentage for coverage would be required to compensate for the rapid failure rate of digital TV signals.

##### (i.2) Micro-scale variations

Measurements carried out in The Netherlands showed that the standard deviation of the micro-scale field strength distribution is about 3 dB. This value has been confirmed by measurements in the United Kingdom. The location variation for micro-scale variations is therefore:

Coverage target	Location variation
>95 %	5 dB
>70 %	1,5 dB

##### (i.3) Macro-scale variations at outdoor locations

ITU-R Recommendation R.370 [17] gives a standard deviation for wide band signals of 5,5 dB. This value is used here for determining the location variation at outdoor locations.

This location variation for macro-scale variations is therefore:

Coverage target	Location variation
>95 %	9 dB
>70 %	2,9 dB

##### (i.4) Signal level prediction

The signal level prediction method to be used will be based on ITU-R Recommendation R.370 [17], bearing in mind that this method shows differences between predicted and measured values, as do all prediction methods. An allowance may need to be made for this inherent source of inaccuracy and the overall signal level strength prediction process should take account of this element in addition to the variation of field strength with location.

##### (i.5) Macro-scale variations at indoor locations

The variation factor at indoor locations is the combined result of the outdoor variation and the variation factor due to building attenuation.

##### (j) Height loss

For portable reception, the antenna height of 10 m above ground level generally used for planning purposes is not realistic and a correction factor needs to be introduced based on a receiving antenna near ground floor level. For this reason a receiving antenna height of 1,5 m above ground level (outdoor) or above floor level (indoor) has been assumed.

The propagation prediction method of ITU-Recommendation R.370 [17] uses a receiving height of 10 m. To correct the predicted values for a receiving height of 1,5 m above ground level a factor called "height loss" has been introduced.

Measurements in The Netherlands at UHF showed a height loss of 12 dB. For VHF, ITU-R Report 1203 [18] gives a value of 10 dB.

**(k) Building penetration loss**

**(k.1) General**

Portable TV reception will take place at outdoor and indoor locations. The field strength at indoor locations will be attenuated significantly by an amount depending on the materials and the construction of the house. A large spread of building penetration losses is to be expected.

**(k.2) Measurements at VHF**

Results of measurements carried out at VHF in the United Kingdom to investigate in-house reception of Digital Audio Broadcasting (DAB) have been reported in ITU-R Report 1203 [18]. The results indicate a median value of building penetration loss of 8 dB with a standard deviation of 3 dB.

**(k.3) Measurements at UHF**

Measurements have been carried out in The Netherlands using a transmitted COFDM signal with a bandwidth of 8 MHz and containing 512 carriers. The measurements were made as samples with a receiver bandwidth of 12 kHz covering the channel in a series of steps.

The signal level was measured as a function of micro-scale variations at indoor and outdoor locations.

It is expected that the value V10 %, which represents the received narrow band signal power exceeded at 10 % of the locations, is most closely related to the wideband received signal level. Therefore, the values of V10 % for indoor, outdoor and 10 m reference measurement sites seem the most well-suited for calculation of loss and gain figures.

It appears that the median value  $M(V10 \%(outdoor)/V10 \%(indoor))$ , which might be a good measure for building penetration loss, is in the order of 6 dB. The standard deviation is estimated to be about 6 dB.

Further measurements carried out in The Netherlands using a transmitted noise signal of 7 MHz and receiver bandwidth of 7 MHz show a median building penetration loss of about 9 dB. However these measurements were done at a limited number of locations. The number of concrete houses was relatively high. This might be the reason for the somewhat higher median value.

The influence of people walking around the receiving antenna has also been estimated. The signal level variations (10 % and 90 % value) ranged from +2,6 dB to -2,6 dB. These variations are relatively small and it does not seem necessary to take them into account for planning purposes.

A number of other measurements have also been carried out in The Netherlands to determine:

- influence of a wet wall;
- time variation of the received signal in a period of 11 days over a short path.

It appeared that neither of these two conditions has a significant influence on the received signal.

Recent measurements carried out in the United Kingdom show combined building penetration and height losses for ground floor rooms between 19 dB and 34 dB with an average value of 29 dB. In upstairs rooms, losses between 16 dB and 29 dB with an average value of 22 dB were found.

**(k.4) Building penetration loss values for planning purposes**

Until more consistent values become available the building penetration loss for planning purposes is taken as in table 9:

**Table 9**

<b>Band</b>	<b>Median value</b>	<b>Standard deviation</b>
VHF	8 dB	3 dB
UHF	7 dB	6 dB

**(k.5) Location distribution indoors**

The variation factor at indoor locations is the combined result of the outdoor variation and the variation factor due to building attenuation. These distributions are expected to be uncorrelated. The standard deviation of the indoor field strength distribution can therefore be calculated by taking the root of the sum of the squares of the individual standard deviations. At VHF, where the macro-scale standard deviations are 5,5 dB and 3 dB respectively, the combined value is 6,3 dB. At UHF, where the macro-scale standard deviations are 5,5 dB and 6,2 dB respectively, the combined value is 8,3 dB.

The location variation for macro-scale variations at indoor locations is therefore at VHF:

Coverage target	Location variation
>95 %	10 dB
>70 %	3 dB

and at UHF:

Coverage target	Location variation
>95 %	14 dB
>70 %	4 dB

The overall field strength prediction process has to take account of both the location variation and the difference between predicted and measured values.

**(l) Portable receiving antenna properties****(l.1) General**

A roof-level antenna as used with fixed reception can be expected to have a gain of about 10 dB to 12 dB at UHF. For a portable receiver the antenna will most probably be of either the built-in type of very short length and in the extreme case having -20 dB gain or at best will be a set-top orientable antenna with a few dB gain (at UHF).

For planning purposes it has been assumed that the antenna of a portable receiver is omni-directional and that the gain is 0 dB for a UHF antenna and -2,2 dB for a VHF antenna. A portable receiver can be assumed to have 0 dB feeder loss. For reference, it may be noted that a roof-level antenna will be connected to a receiver by means of a feeder cable. This is likely to have a loss of 3 dB to 5 dB at UHF. Such values may seem high when the relatively short feeder lengths are considered, but some allowance has to be included for feeder ageing effects ( for example, corrosion of the copper screening).

**(l.2) Measurements of indoor antennas**

Measurements have been carried out in The Netherlands to investigate directivity of set-top antennas in practical circumstances. One "rabbit-ear" and two five element Yagi antennas of moderate quality have been selected. The results showed that gain and directivity depend very much on frequency and location.

The gain varied from about -15 dB to +3 dB for the Yagi antennas and from about -10 dB to -4 dB for the "rabbit ear" antenna.

For directivity measurements the antennas were placed in a room close to a wall to represent practical conditions.

The radiation patterns changed considerably with the frequency.

In practical conditions the antenna should therefore be directed to obtain the highest signal rather than in the direction of the transmitter (assuming that this is even known).

Figure 15: Examples of indoor antenna patterns

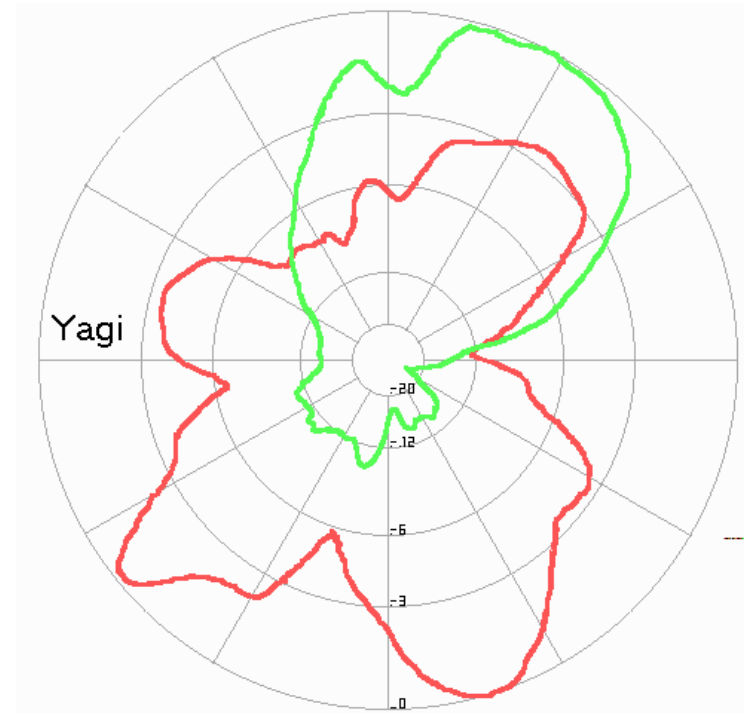
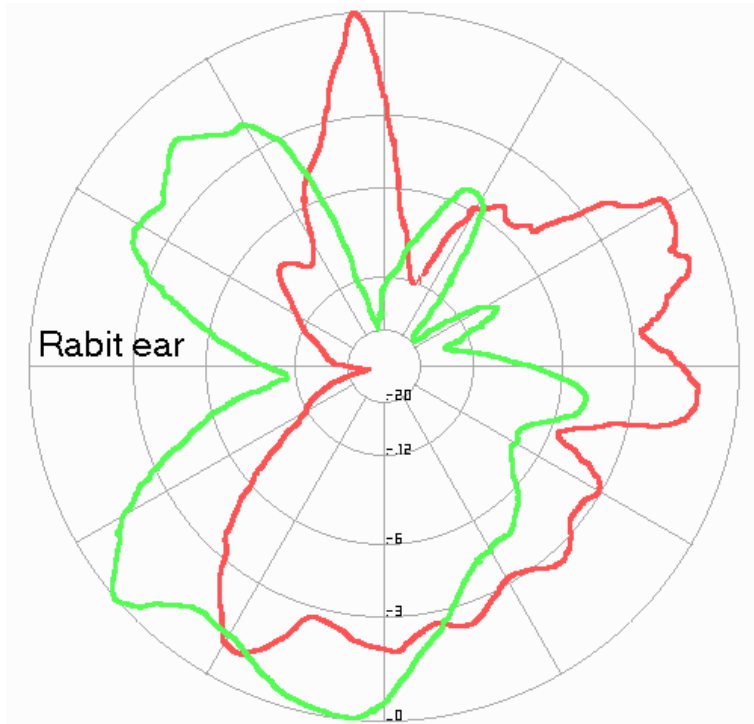



Examples of antenna patterns for two antenna types at an indoor location close to a wall, measured in The Netherlands, are shown in figure 15.

Measurements by the British Broadcasting Corporation (UK) (BBC) of two commercially available indoor antennas showed a better performance. The antennas had a gain of 5 dB to 6 dB throughout Band IV and V.

### **(l.3) Measurements of depolarization**

Measurements carried out in The Netherlands, using test transmissions with a vertically polarized digital TV signal, showed a depolarization of the signal at the receiving site and in particular for indoor reception.

The results showed that indoors the depolarization angle ranges from 20° to 48° at macro-scale.

At micro-scale level the standard deviation of the depolarization angle ranges from 3° to 16°.

### **(m) Receiver properties**

Planning studies for portable reception are based on a receiver able to handle signals of a broadband nature and the carrier to noise ratio requirement of a system will be moderate and may be as low as 2 dB in the case of a particularly rugged system. However, multi-channel services may need to be received by receivers having simple antennas. In practice, the possibilities for portable reception of signals with high bit-rates and requiring a C/N of 20 dB to 26 dB will be very restricted due to the high signal level requirements.

For these studies it has been assumed that a portable receiver and a receiver for fixed reception have same receiver noise figure, that is 7 dB.

#### **9.2.2.3.3 Minimum median power flux density and equivalent field strength**

The tables below give the minimum median power flux density and the minimum median equivalent field strength for location probabilities of 70 % and 95 % in Band I, III, IV and V.

**Table 10: Minimum median power flux density and equivalent minimum median field strength in Band I for 70 % and 95 % location probability, portable outdoor reception**

**Receiving condition: Portable outdoor (Class A), Band I.**

Frequency Minimum C/N required by system	f (MHz) (dB)	65				
		2	8	14	20	26
Min. receiver signal input power	$P_{s \text{ min}}$ (dBW)	-126,2	-120,2	-114,2	-108,2	-102,2
Min. equivalent receiver input voltage, 75 $\Omega$	$U_{s \text{ min}}$ (dB $\mu$ V)	13	19	25	31	37
Antenna gain relative to half wave dipole	$G_a$ (dB)	-2,2				
Effective antenna aperture	$A_a$ (dBm <sup>2</sup> )	2,2				
Min power flux density at receiving place	$\phi_{\text{min}}$ (dBW/m <sup>2</sup> )	-128,5	-122,5	-116,5	-110,5	-104,5
Min equivalent field strength at receiving place	$E_{\text{min}}$ (dB $\mu$ V/m)	17	23	29	35	41
Allowance for man made noise	$P_{\text{mmn}}$ (dB)	6				
Height loss	$L_h$ (dB)	10				
<b>Location probability: 70 %</b>						
Location correction factor	$C_l$ (dB)	2,9				
Minimum median power flux density at 10 m a.g.l. 50 % of time and 50 % of locations	$\phi_{\text{med}}$ (dBW/m <sup>2</sup> )	-109,6	-103,6	-97,6	-91,6	-85,6
Minimum median equivalent field strength at 10 m a.g.l. 50 % of time and 50 % of locations	$E_{\text{med}}$ (dB $\mu$ V/m)	36	42	48	54	60
<b>Location probability: 95 %</b>						
Location correction factor	$C_l$ (dB)	9				
Minimum median power flux density at 10 m a.g.l. 50 % of time and 50 % of locations	$\phi_{\text{med}}$ (dBW/m <sup>2</sup> )	-103,6	-97,5	-91,5	-89,5	-79,5
Minimum median equivalent field strength at 10 m a.g.l. 50 % of time and 50 % of locations	$E_{\text{med}}$ (dB $\mu$ V/m)	42	48	54	60	66

**Table 11: Minimum median power flux density and equivalent minimum median field strength in Band III for 70 % and 95 % location probability, portable outdoor reception**

**Receiving condition: Portable outdoor (Class A), Band III**

Frequency	f (MHz)	200				
		Minimum C/N required by system (dB)				
Minimum C/N required by system	(dB)	2	8	14	20	26
Min. receiver signal input power	$P_{s \text{ min}}$ (dBW)	-126,2	-120,2	-114,2	-108,2	-102,2
Min. equivalent receiver input voltage, 75 $\Omega$	$U_{s \text{ min}}$ (dB $\mu$ V)	13	19	25	31	37
Antenna gain relative to half wave dipole	$G_a$ (dB)	-2,2				
Effective antenna aperture	$A_a$ (dBm <sup>2</sup> )	-7,5				
Min power flux density at receiving place	$\phi_{\text{min}}$ (dBW/m <sup>2</sup> )	-118,7	-112,7	-106,7	-100,7	-94,7
Min equivalent field strength at receiving place	$E_{\text{min}}$ (dB $\mu$ V/m)	27	33	39	45	51
Allowance for man made noise	$P_{\text{mmn}}$ (dB)	1				
Height loss	$L_h$ (dB)	10				
<b>Location probability: 70 %</b>						
Location correction factor	$C_l$ (dB)	2,9				
Minimum median power flux density at 10 m a.g.l. 50 % of time and 50 % of locations	$\phi_{\text{med}}$ (dBW/m <sup>2</sup> )	-104,8	-98,8	-92,8	-86,8	-80,8
Minimum median equivalent field strength at 10 m a.g.l. 50 % of time and 50 % of locations	$E_{\text{med}}$ (dB $\mu$ V/m)	41	47	53	59	65
<b>Location probability: 95 %</b>						
Location correction factor	$C_l$ (dB)	9				
Minimum median power flux density at 10 m a.g.l. 50 % of time and 50 % of locations	$\phi_{\text{med}}$ (dBW/m <sup>2</sup> )	-98,7	-92,7	-86,7	-80,7	-74,7
Minimum median equivalent field strength at 10 m a.g.l. 50 % of time and 50 % of locations	$E_{\text{med}}$ (dB $\mu$ V/m)	47	53	59	65	71

**Table 12: Minimum median power flux density and equivalent minimum median field strength in Band IV for 70 % and 95 % location probability, portable outdoor reception**

**Receiving condition: Portable outdoor (Class A), Band IV**

Frequency Minimum C/N required by system	f (MHz) (dB)	500				
		2	8	14	20	26
Min. receiver signal input power	$P_{s \min}$ (dBW)	-126,2	-120,2	-114,2	-108,2	-102,2
Min. equivalent receiver input voltage, 75 $\Omega$	$U_{s \min}$ (dB $\mu$ V)	13	19	25	31	37
Antenna gain relative to half wave dipole	$G_a$ (dB)	0				
Effective antenna aperture	$A_a$ (dBm <sup>2</sup> )	-13,3				
Min power flux density at receiving place	$\phi_{\min}$ (dBW/m <sup>2</sup> )	-112,9	-106,9	-100,9	-94,9	-88,9
Min equivalent field strength at receiving place	$E_{\min}$ (dB $\mu$ V/m)	33	39	45	51	57
Allowance for man made noise	$P_{mmn}$ (dB)	0				
Height loss	$L_h$ (dB)	12				
<b>Location probability: 70 %</b>						
Location correction factor	$C_{lc}$ (dB)	2,9				
Minimum median power flux density at 10 m a.g.l. 50 % of time and 50 % of locations	$\phi_{\text{med}}$ (dBW/m <sup>2</sup> )	-98	-92	-86	-80	-74
Minimum median equivalent field strength at 10 m a.g.l. 50 % of time and 50 % of locations	$E_{\text{med}}$ (dB $\mu$ V/m)	48	54	60	66	72
<b>Location probability: 95 %</b>						
Location correction factor	$C_{lc}$ (dB)	9				
Minimum median power flux density at 10 m a.g.l. 50 % of time and 50 % of locations	$\phi_{\text{med}}$ (dBW/m <sup>2</sup> )	-91,9	-85,9	-79,9	-73,9	-67,9
Minimum median equivalent field strength at 10 m a.g.l. 50 % of time and 50 % of locations	$E_{\text{med}}$ (dB $\mu$ V/m)	54	60	66	72	78

**Table 13: Minimum median power flux density and equivalent minimum median field strength in Band V for 70 % and 95 % location probability, portable outdoor reception**

**Receiving condition: Portable outdoor (Class A), Band V**

Frequency Minimum C/N required by system	f (MHz) (dB)	800				
		2	8	14	20	26
Min. receiver signal input power	$P_{s \text{ min}}$ (dBW)	-126,2	-120,2	-114,2	-108,2	-102,2
Min. equivalent receiver input voltage, 75 $\Omega$	$U_{s \text{ min}}$ (dB $\mu$ V)	13	19	25	31	37
Antenna gain rel. to half wave dipole	$G_a$ (dB)	0				
Effective antenna aperture	$A_a$ (dBm <sup>2</sup> )	-17,4				
Min power flux density at receiving place	$\phi_{\text{min}}$ (dBW/m <sup>2</sup> )	-108,8	-102,8	-96,8	-90,8	-84,8
Min equivalent field strength at receiving place	$E_{\text{min}}$ (dB $\mu$ V/m)	37	43	49	55	61
Allowance for man made noise	$P_{\text{mmn}}$ (dB)	0				
Height loss	$L_h$ (dB)	12				
<b>Location probability: 70 %</b>						
Location correction factor	$C_l$ (dB)	2,9				
Minimum median power flux density at 10 m a.g.l. 50 % of time and 50 % of locations	$\phi_{\text{med}}$ (dBW/m <sup>2</sup> )	93,9	-87,9	-81,9	-75,9	-69,9
Minimum median equivalent field strength at 10 m a.g.l. 50 % of time and 50 % of locations	$E_{\text{med}}$ (dB $\mu$ V/m)	52	58	64	70	76
<b>Location probability: 95 %</b>						
Location correction factor	$C_l$ (dB)	9				
Minimum median power flux density at 10 m a.g.l. 50 % of time and 50 % of locations	$\phi_{\text{med}}$ (dBW/m <sup>2</sup> )	-87,8	-81,8	-75,8	-69	-63,8
Minimum median equivalent field strength at 10 m a.g.l. 50 % of time and 50 % of locations	$E_{\text{med}}$ (dB $\mu$ V/m)	58	64	70	76	82

**Table 14: Minimum median power flux density and equivalent minimum median field strength in Band I for 70 % and 95 % location probability, portable indoor reception at ground floor**

**Receiving condition: Portable indoor ground floor (Class B), Band I**

Frequency Minimum C/N required by system	f (MHz) (dB)	65				
		2	8	14	20	26
Min. receiver signal input power	$P_{s \text{ min}}$ (dBW)	-126,2	-120,2	-114,2	-108,2	-102,2
Min. equivalent receiver input voltage, 75 $\Omega$	$U_{s \text{ min}}$ (dB $\mu$ V)	13	19	25	31	37
Antenna gain relative to half wave dipole	$G_a$ (dB)	-2,2				
Effective antenna aperture	$A_a$ (dBm <sup>2</sup> )	2,2				
Min power flux density at receiving place	$\phi_{\text{min}}$ (dBW/m <sup>2</sup> )	-128,4	-122,4	-116,4	-110,4	-104,4
Min equivalent field strength at receiving place	$E_{\text{min}}$ (dB $\mu$ V/m)	17	23	29	35	41
Allowance for man made noise	$P_{\text{mmn}}$ (dB)	6				
Height loss	$L_h$ (dB)	10				
Building penetration loss	$L_b$ (dB)	8				
<b>Location probability: 70 %</b>						
Location correction factor	$C_l$ (dB)	3				
Minimum median power flux density at 10 m a.g.l. 50 % of time and 50 % of locations	$\phi_{\text{med}}$ (dBW/m <sup>2</sup> )	-101,4	-95,4	-89,4	-83,4	-77,4
Minimum median equivalent field strength at 10 m a.g.l. 50 % of time and 50 % of locations	$E_{\text{med}}$ (dB $\mu$ V/m)	44	50	56	62	68
<b>Location probability: 95 %</b>						
Location correction factor	$C_l$ (dB)	10				
Minimum median power flux density at 10 m a.g.l. 50 % of time and 50 % of locations	$\phi_{\text{med}}$ (dBW/m <sup>2</sup> )	-94,4	-88,4	-82,4	-76,4	-70,4
Minimum median equivalent field strength at 10 m a.g.l. 50 % of time and 50 % of locations	$E_{\text{med}}$ (dB $\mu$ V/m)	51	57	63	69	75
NOTE: Minimum median equivalent field strength values at 10 m a.g.l. for 50 % of time and 50 % of locations are expected to be:  -5 dB lower than the values shown if reception is required in rooms at the first floor;  -10 dB lower than the values shown if reception is required in rooms higher than the first floor.						

**Table 15: Minimum median power flux density and equivalent minimum median field strength in Band III for 70 % and 95 % location probability, portable indoor reception at ground floor**

**Receiving condition: Portable indoor ground floor (Class B), Band III**

Frequency	f (MHz)	200				
		Minimum C/N required by system (dB)				
		2	8	14	20	26
Min. receiver signal input power	$P_{s \text{ min}}$ (dBW)	-126,2	-120,2	-114,2	-108,2	-102,2
Min. equivalent receiver input voltage, 75 $\Omega$	$U_{s \text{ min}}$ (dB $\mu$ V)	13	19	25	31	37
Antenna gain relative to half wave dipole	$G_a$ (dB)	-2,2				
Effective antenna aperture	$A_a$ (dBm <sup>2</sup> )	-7,5				
Min power flux density at receiving place	$\phi_{\text{min}}$ (dBW/m <sup>2</sup> )	-118,7	-112,7	-106,7	-100,7	-94,7
Min equivalent field strength at receiving place	$E_{\text{min}}$ (dB $\mu$ V/m)	27	33	39	45	51
Allowance for man made noise	$P_{\text{mmn}}$ (dB)	1				
Height loss	$L_h$ (dB)	10				
Building penetration loss	$L_b$ (dB)	8				
<b>Location probability: 70 %</b>						
Location correction factor	$C_l$ (dB)	3				
Minimum median power flux density at 10 m a.g.l. 50 % of time and 50 % of locations	$\phi_{\text{med}}$ (dBW/m <sup>2</sup> )	-96,7	-90,7	-84,7	-78,7	-72,7
Minimum median equivalent field strength at 10 m a.g.l. 50 % of time and 50 % of locations	$E_{\text{med}}$ (dB $\mu$ V/m)	49	55	61	67	73
<b>Location probability: 95 %</b>						
Location correction factor	$C_l$ (dB)	10				
Minimum median power flux density at 10 m a.g.l. 50 % of time and 50 % of locations	$\phi_{\text{med}}$ (dBW/m <sup>2</sup> )	-89,7	-83,7	-77,7	-71,7	-65,7
Minimum median equivalent field strength at 10 m a.g.l. 50 % of time and 50 % of locations	$E_{\text{med}}$ (dB $\mu$ V/m)	56	62	68	74	80
NOTE: Minimum median equivalent field strength values at 10 m a.g.l. for 50 % of time and 50 % of locations are expected to be:						
5 dB lower than the values shown if reception is required in rooms at the first floor;						
10 dB lower than the values shown if reception is required in rooms higher than the first floor.						

**Table 16: Minimum median power flux density and equivalent minimum median field strength in Band IV for 70 % and 95 % location probability, portable indoor reception at ground floor**

**Receiving condition: Portable indoor ground floor (Class B), Band IV**

Frequency		f (MHz)		500				
Minimum C/N required by system		(dB)		2	8	14	20	26
Min. receiver signal input power	$P_{s \text{ min}}$ (dBW)	-126,2	-120,2	-114,2	-108,2	-102,2		
Min. equivalent receiver input voltage, 75 $\Omega$	$U_{s \text{ min}}$ (dB $\mu$ V)	13	19	25	31	37		
Antenna gain relative to half wave dipole	$G_a$ (dB)	0						
Effective antenna aperture	$A_a$ (dBm <sup>2</sup> )	-13,3						
Min power flux density at receiving place	$\phi_{\text{min}}$ (dBW/m <sup>2</sup> )	-112,9	-106,9	-100,9	-94,9	-88,9		
Min equivalent field strength at receiving place	$E_{\text{min}}$ (dB $\mu$ V/m)	33	39	45	51	57		
Allowance for man made noise	$P_{\text{mmn}}$ (dB)	0						
Height loss	$L_h$ (dB)	12						
Building penetration loss	$L_b$ (dB)	7						
<b>Location probability: 70 %</b>								
Location correction factor	$C_l$ (dB)	4						
Minimum median power flux density at 10 m a.g.l. 50 % of time and 50 % of locations	$\phi_{\text{med}}$ (dBW/m <sup>2</sup> )	-89,9	-83,9	-77,9	-71,9	-65,9		
Minimum median equivalent field strength at 10 m a.g.l. 50 % of time and 50 % of locations	$E_{\text{med}}$ (dB $\mu$ V/m)	56	62	68	74	80		
<b>Location probability: 95 %</b>								
Location correction factor	$C_l$ (dB)	14						
Minimum median power flux density at 10 m a.g.l. 50 % of time and 50 % of locations	$\phi_{\text{med}}$ (dBW/m <sup>2</sup> )	-79,9	-73,9	-67,9	-61,9	-55,9		
Minimum median equivalent field strength at 10 m a.g.l. 50 % of time and 50 % of locations	$E_{\text{med}}$ (dB $\mu$ V/m)	66	72	78	84	90		
NOTE:	Minimum median equivalent field strength values at 10 m a.g.l. for 50 % of time and 50 % of locations are expected to be:							
	6 dB lower than the values shown if reception is required in rooms at the first floor;							
	12 dB lower than the values shown if reception is required in rooms higher than the first floor.							



**Table 17: Minimum median power flux density and equivalent minimum median field strength in Band V for 70 % and 95 % location probability, portable indoor reception at ground floor**

**Receiving condition: Portable indoor ground floor (Class B), Band V**

Frequency	f (MHz)	800				
		Minimum C/N required by system (dB)				
		2	8	14	20	26
Min. receiver signal input power	$P_{s \text{ min}}$ (dBW)	-126,2	-120,2	-114,2	-108,2	-102,2
Min. equivalent receiver input voltage, 75 $\Omega$	$U_{s \text{ min}}$ (dB $\mu$ V)	13	19	25	31	37
Antenna gain rel. to half wave dipole	$G_a$ (dB)	0				
Effective antenna aperture	$A_a$ (dBm <sup>2</sup> )	-17,4				
Min power flux density at receiving place	$\phi_{\text{min}}$ (dBW/m <sup>2</sup> )	-108,8	-102,8	-96,8	-90,8	-84,8
Min equivalent field strength at receiving place	$E_{\text{min}}$ (dB $\mu$ V/m)	37	43	49	55	61
Allowance for man made noise	$P_{\text{mmn}}$ (dB)	0				
Height loss	$L_h$ (dB)	12				
Building penetration loss	$L_b$ (dB)	7				
<b>Location probability: 70 %</b>						
Location correction factor	$C_l$ (dB)	4				
Minimum median power flux density at 10 m a.g.l. 50 % of time and 50 % of locations	$\phi_{\text{med}}$ (dBW/m <sup>2</sup> )	-85,8	-79,8	-73,8	-67,8	-61,8
Minimum median equivalent field strength at 10 m a.g.l. 50 % of time and 50 % of locations	$E_{\text{med}}$ (dB $\mu$ V/m)	60	66	72	78	84
<b>Location probability: 95 %</b>						
Location correction factor	$C_l$ (dB)	14				
Minimum median power flux density at 10 m a.g.l. 50 % of time and 50 % of locations	$\phi_{\text{med}}$ (dBW/m <sup>2</sup> )	-75,8	-69,8	-63,8	-57,8	-51,8
Minimum median equivalent field strength at 10 m a.g.l. 50 % of time and 50 % of locations	$E_{\text{med}}$ (dB $\mu$ V/m)	70	76	82	88	94
NOTE: Minimum median equivalent field strength values at 10 m a.g.l. for 50 % of time and 50 % of locations are expected to be:						
6 dB lower than the values shown if reception is required in rooms at the first floor;						
12 dB lower than the values shown if reception is required in rooms higher than the first floor						

### 9.3 Aspects of sharing with existing services

Frequency planning for the introduction of a new broadcasting service is based on two main parameters of the transmission system; the required Carrier to Noise ratio (C/N) and the protection ratios (PR) needed to achieve a given quality target for the delivered signal (e.g. video and audio).

Since the system is being designed for terrestrial digital TV services primarily to operate within the existing UHF (see note) spectrum allocation for analogue transmissions, it is required that the system provides sufficient protection against high levels of Co-Channel Interference (CCI) and Adjacent-Channel Interference (ACI) emanating from existing PAL/SECAM services. Any modified system intended to operate in the existing VHF spectrum allocations for television would also need to achieve similar protection.

NOTE: i.e. 8 MHz channel spacing. An adaptation of this specification for 7 MHz channels can be achieved by scaling down all system parameters by multiplying the system clock rate by a factor of 7/8. The frame structure and the rules for coding, mapping and interleaving are kept, only the data capacity of the system is reduced by a factor of 7/8 due to the reduction of signal bandwidth.

### 9.3.1 Protection ratios

The reference power for protection ratio evaluation is:

- for DVB-T, the average signal power (heating) of the COFDM signal measured in the system bandwidth;
- for analogue television, generally, the rms power of the vision signal at the sync peak, but in the case of SECAM L, the peak white level.

The protection ratios relevant to a given interference are evaluated without noise or other interference, at the relevant quality target, and are expressed in dB.

For a wanted DVB-T signal the required protection ratios are preferably measured for a BER of  $2 \times 10^{-4}$  after Viterbi decoding, corresponding to a BER of  $< 1 \times 10^{-11}$  at the input of the MPEG-2 demultiplexer, and to approximately one uncorrected error per hour. In case of digital signals as wanted signal, all protection ratio values relate to both tropospheric and continuous interference.

For analogue television wanted signals, tropospheric interference is determined for quality grade 3 and continuous interference for quality grade 4.

For adjacent channel and overlapping channel cases the protection ratio values are related to an out-of-channel spectrum attenuation of 40 dB. This 40 dB figure is only used for protection ratio measurements and is not recommended for real DVB-T transmitters.

The ITU reference document is ITU-R Recommendation: "Planning Criteria for Digital Terrestrial Television Services in the VHF/UHF Television Bands" (at present numbered Rec. ITU-R. XYZ) [19]. The ITU modes, M1, M2, and M3 are defined in this recommendation.

NOTE: The values given here are taken from CEPT, Chester 1997 Multilateral Coordination Agreement [15]. They are based on tests with experimental receivers; tests with prototype domestic tuners intended for DVB-T indicate that better protection ratios may be achieved in practice.

#### 9.3.1.1 DVB-T interfered with by DVB-T

Table 18 gives co-channel Protection Ratios (rounded to the nearest integer), obtained by measurements or by the extrapolation method given below.

**Table 18: Co-channel protection ratios (dB) for DVB-T interfered with by DVB-T**

ITU-Mode	Modulation	Code rate	PR (see note 1) Gaussian	PR (see note 2) Rice	PR (see note 2) Rayleigh
	QPSK	1/2	5	7	8
M1	16-QAM	1/2		13	14
	16-QAM	3/4	14	16	20
M2	64-QAM	1/2		18	19
M3	64-QAM	2/3	19	20	22
NOTE 1: Measurement result, IF loop, 2k mode.					
NOTE 2: Extrapolated result.					

Protection ratios for the various modes and for the various channel types (i.e. Gaussian, Ricean, or Rayleigh) can be derived by the required C/N given in table A.1 of EN 300 744 [5], increased by a system implementation loss  $\Delta_1$  of 3 dB. For fixed and portable reception, the figures relevant to the Ricean and Rayleigh channels respectively should be adopted.

For **adjacent and image channel interference** a protection ratio of -40 dB is assumed to be an appropriate value due to lack of data.

For **overlapping channels**, in the absence of measurement information, the protection ratio should be extrapolated from the co-channel ratio figure as follows:

- $PR = PR(CCI) + 10 \log_{10} (BO / BW)$ ;
- PR(CCI) is the co-channel ratio;
- BO is the bandwidth (in MHz) in which the two DVB-T signals are overlapping;
- BW is the bandwidth (in MHz) of the wanted signal;
- PR = -40 dB should be used when the above formula gives  $PR < -40$  dB.

### 9.3.1.2 DVB-T interfered with by analogue television

The protection ratios for wanted DVB-T apply to both continuous and tropospheric interference.

In all tables the so-called non-controlled frequency conditions are used. Introducing precisely controlled frequency offsets between the analogue and digital signals, significant lower co-channel required signal to interference ratios have been measured. With precisely controlled frequency position lower protection values can be reached. Further studies of using controlled offset for DVB-T are necessary.

#### 9.3.1.2.1 Co-channel protection ratios

According to the available measurements the same protection ratio values are applicable for 2k and 8k modes.

**Table19: Co-channel protection ratios (dB) for DVB-T 7 and 8 MHz interfered with by analogue TV and CW (non-controlled frequency condition)**

Constellation	Protection Ratio														
	QPSK					16QAM					64 QAM				
	1/2	2/3	3/4	5/6	7/8	1/2	2/3	3/4	5/6	7/8	1/2	2/3	3/4	5/6	7/8
ITU-Mode						M1					M2	M3			
CW and PAL/SECAM with teletext and sound carriers	-12	-8	-5	2	6	-8	-4	0	9	16	-3	4	10	17	24

The PAL/SECAM figures are valid for all sound carrier modes used in Europe, these are:

- MONO FM with a single sound carrier at -10 dB referred to the vision carrier;
- DUAL FM and FM + NICAM with two sound carriers at -13 dB and -20 dB level;
- AM + NICAM with two sound carriers at respectively -10 dB and -27dB.

The values contained in this table represent the present knowledge of behaviour of the DVB-T systems and are derived from a limited number of measurements mainly with 2k systems. There is a general confidence that the final results will not differ by more than 3 dB.

## 9.3.1.2.2 Lower adjacent channel (n - 1)

**Table 20: Protection ratios (dB) for DVB-T interfered with by analogue TV in the lower adjacent channel (n - 1)**

Wanted signal			Interfering signal					
System	BW	Mode	PAL B	PAL G,B1	PAL I	PAL D,K	SECAM L	SECAM D,K
		M1			-43			
DVB-T	8 MHz	M2			-38			
		M3			-34			
		M1	-43					
DVB-T	7 MHz	M2	-40					
		M3	-37					

## 9.3.1.2.3 Upper adjacent channel (n + 1)

**Table 21: Protection ratios (dB) for DVB-T interfered with by analogue TV in the upper adjacent channel (n + 1)**

Wanted signal			Interfering signal					
System	BW	Mode	PAL B	PAL B1, G	PAL I	PAL D,K	SECAM L	SECAM D,K
		M1			-46			
DVB-T	8 MHz	M2			-40			
		M3			-38			
		M1	-43					
DVB-T	7 MHz	M2	-38					
		M3	-36					

## 9.3.1.2.4 Image channel

**Table 22: Protection ratios (dB) for DVB-T interfered with by analogue TV in the image channel**

Wanted signal			Interfering signal					
System	BW	Mode	PAL B	PAL G,B1	PAL I	PAL D,K	SECAM L	SECAM D,K
		M1			-58			
DVB-T	8 MHz	M2			-50			
		M3			-46			

NOTE: The protection ratios in this table will depend on the intermediate frequency of the receiver.

## 9.3.1.2.5 Overlapping channels

NOTE: Protection ratio values for the overlapping channel cases are provisional and will need to be confirmed within the ITU-R.

The frequency difference  $\Delta F$  is the vision carrier frequency of the analogue television signal minus the centre frequency of the DVB-T signal.

**Table 23: Protection ratios (dB) for DVB-T 8 MHz interfered with by overlapping PAL B**

DVB-T 8 MHz (ITU-M3, 64 QAM rate 2/3)													
$\Delta F$ (MHz)	-9,75	-9,25	-8,75	-8,25	-6,75	-3,95	-3,75	-2,75	-0,75	2,25	3,25	4,75	5,25
PR	-37	-14	-8	-4	-2	1	4	4	4	2	-1	-29	-36

**Table 24: Protection ratios (dB) for DVB-T 7 MHz interfered with by overlapping PAL B1, D**

DVB-T 7 MHz (ITU-M3, 64 QAM rate 2/3)													
$\Delta F$ (MHz) for B1	-9,25	-8,75	-8,25	-7,75	-6,25	-3,45	-3,25	-2,25	-1,25	-1,75	2,75	4,25	4,75
$\Delta F$ (MHz) for D	-10,25	-9,75	-9,25	-8,75	-7,25	-3,45	-3,25	-2,25	-1,25	-1,75	2,75	4,25	4,75
PR	-37	-14	-8	-4	-2	1	4	4	4	2	-1	-29	-36

### 9.3.1.3 Analogue TV interfered with by DVB-T

The values of protection ratio quoted apply to interference produced by a single source. In this subclause the protection ratios for a wanted analogue signal interfered with by an unwanted digital signal apply only to the interference to the vision and colour signals, i.e. excluding sound signals.

The tropospheric interference corresponds to impairment grade 3, that is, acceptable for a small percentage of the time, between 1% and 10%. The continuous interference corresponds to an impairment grade 4, that is, acceptable for 50% of time.

The protection ratio measurements for wanted analogue television signals should be made using the method given in the ANNEX of Rec. ITU-R XYZ [19]. For the co-channel case, the digital interference from a DVB-T signal has a similar effect to Gaussian noise of equal power in the receiver bandwidth.

#### 9.3.1.3.1 Co-channel protection ratios

**Table 25: Protection ratios (dB) for an analogue vision signal interfered with by DVB-T 8 MHz**

Wanted analogue system	Tropospheric interference	Continuous interference
PAL B, B1, G, D, K	34	40
PAL I	37	41
SECAM L	37	42
SECAM D,K	35	41
NOTE: These figures are taken from Rec. ITU-R XYZ and may be updated as a result of further measurements.		

**Table 26: Protection ratios (dB) for an analogue vision signal interfered with by DVB-T 7 MHz**

Wanted analogue system	Tropospheric interference	Continuous interference
PAL B	35	41
NOTE: These figures are taken from Rec. ITU-R XYZ and may be updated as a result of further measurements.		

#### 9.3.1.3.2 Lower adjacent channel (n - 1)

**Table 27: Protection ratios (dB) for an analogue vision signal interfered with by lower adjacent channel DVB-T 8 MHz**

Wanted analogue system	Tropospheric interference	Continuous interference
PAL B1, G, D, K	-7	-4
PAL I	-8	-4
SECAM L	-9	-7
SECAM D,K	-5	-1

**Table 28: Protection ratios (dB) for an analogue vision signal interfered with by lower adjacent channel DVB-T 7 MHz**

Wanted analogue system	Tropospheric interference	Continuous interference
PAL B	-11	-4

9.3.1.3.3 Upper adjacent channel ( $n + 1$ )

**Table 29: Protection ratios (dB) for an analogue vision signal interfered with by upper adjacent channel DVB-T 8 MHz**

Wanted analogue system	Tropospheric interference	Continuous interference
PAL B1, G	-9	-7
PAL I	-10	-6
SECAM L	-1	-1
SECAM D, K	-8	-5
PAL D, K		

**Table 30: Protection ratios (dB) for an analogue vision signal interfered with by upper adjacent channel DVB-T 7 MHz**

Wanted analogue system	Tropospheric interference	Continuous interference
PAL B	-5	-3

9.3.1.3.4 Image channel

**Table 31: Protection ratios (dB) for an analogue vision signal interfered with by image channel DVB-T 8 MHz**

Wanted analogue system	Unwanted DVB-T channel	Tropospheric interference	Continuous interference
PAL B1, G	$n + 9$	-19	-15
PAL I	$n + 9$		
SECAM L	$n - 9$	-25	-22
SECAM D, K	$n + 8$	-16	-11
SECAM D, K	$n + 9$	-16	-11
PAL D, K	$n + 8$		
PAL D, K	$n + 9$		

9.3.1.3.5 Overlapping channels

NOTE: Protection ratio values for the overlapping channel cases are provisional and will need to be confirmed within the ITU-R.

**Table 32: Protection ratios (dB) for a PAL B1, D vision signal interfered with by overlapping channel DVB-T 7 MHz**

Frequency Difference (MHz) between DVB-T and PAL signals	Tropospheric interference	Continuous interference
Centre frequency of DVB-T signal minus the vision carrier frequency of the analogue television signal		
-7,75	-13	-8
-4,75 channel n - 1	-10	-4
-4,25	-4	2
-3,75	14	21
-3,25	25	32
-2,75	31	37
-1,75	34	41
-0,75	35	41
2,25 co-channel n	35	41
4,25	35	41
5,25	32	38
7,25	25	34
7,75	20	29
8,25	6	13
8,75	-5	-2
9,25 channel n + 1	-7	-4
12,25	-9	-3

**Table 33: Protection ratios (dB) for a PAL B vision signal interfered with by overlapping channel DVB-T 8 MHz**

Frequency difference (MHz) between DVB-T and PAL signals	Tropospheric interference	Continuous interference
Centre frequency of DVB-T signal minus the vision carrier frequency of the analogue television signal		
-7,25	-11	-6
-5,25	-10	-1
-3,75	13	20
-3,25	24	31
-2,75	30	36
-2,25	33	40
-1,25	34	40
-0,25	34	40
2,75 co-channel n	34	40
4,75	34	40
5,75	33	39
7,75	27	35
8,25	24	33
8,75	19	28
9,25	5	12
10,75	-5	-3
12,75	-7	-2

NOTE: This table is derived from Table 32, relating to an unwanted DVB-T 7 MHz interferer.

### 9.3.1.4 Sound signals associated with analogue television, interfered with by DVB-T

In this subclause, all values quoted refer to the level of the wanted sound carrier.

The reference signal-to-noise ratios (S/N, peak-to-peak weighted) for analogue sound signals are:

- 40 dB for tropospheric interference (approximates to impairment grade 3);
- 48 dB for continuous interference (approximates to impairment grade 2).

The reference bit-error rates for NICAM digital sound signals are:

- $1 \times 10^{-4}$  for tropospheric interference (approximates to impairment grade 3);
- $1 \times 10^{-5}$  for continuous interference (approximates to impairment grade 4).

In the case of a two-sound-carrier transmission, each of the two-sound signals have to be considered separately.

**Table 34: Protection ratios (dB) for a sound signal associated with analogue television, interfered with by DVB-T**

Protection Ratio in dB Wanted sound signal		Interfering signal	
		DVB-T 7 MHz	DVB-T 8 MHz
FM	Tropospheric	6	5
	Continuous	16	15
AM	Tropospheric		
	Continuous		
NICAM System B, B1, G	Tropospheric		
	Continuous		
NICAM System L	Tropospheric		
	Continuous		
NICAM System I	Tropospheric		
	Continuous		
NOTE: 0 kHz frequency separation between the wanted sound carrier and the centre frequency of the DVB-T signal.			

**Table 35: Protection ratios (dB) for an analogue television FM sound signal interfered with by DVB-T 8 MHz**

DVB-T 8 MHz (The frequency difference $\Delta F$ is the centre frequency of DVB-T signal minus the centre frequency of FM sound signal in MHz)									
Frequency difference $\Delta F$	-5 (note)	-4,2 (note)	-4	-3,5	0	3,5	4	4,2	4,5
Tropospheric interference	-1	-1	4	5	5	4	2	-18	-33
Continuous interference	8	8	13	15	15	14	11	-12	-28
NOTE: The required higher protection at lower frequencies is caused by intercarrier distortions of the vision carrier.									



**Table 36: Protection ratios (dB) for an analogue television FM sound signal interfered with by DVB-T 7 MHz**

DVB-T 7 MHz (The frequency difference $\Delta F$ is the centre frequency of DVB-T signal minus the centre frequency of FM sound signal in MHz)									
Frequency difference $\Delta F$	-5 (see note)	-3,7 (see note)	-3,5	-3	0	3	3,5	3,7	>,4
Tropospheric interference	0	0	5	6	6	5	3	-17	< -32
Continuous interference	9	9	14	16	16	15	12	-11	<-27

NOTE: The required higher protection at lower frequencies is caused by intercarrier distortions of the vision carrier.

### 9.3.1.5 DVB-T interfered with by T-DAB

**Table 37: Protection ratios (dB) for a DVB-T 8 MHz interfered with by T-DAB**

DVB-T 8 MHz (ITU Mode M3, 64 QAM, 2/3 code rate)									
$\Delta F$ = Centre frequency of T-DAB minus centre frequency of DVB-T									
$\Delta F$ (MHz)	-5	-4,2	-4	-3	0	3	4	4,2	5
PR	-30	-6	-5	28	29	28	-5	-6	-30

**Table 38: Protection ratios (dB) for a DVB-T 7 MHz interfered with by T-DAB**

DVB-T 7 MHz (ITU Mode M3, 64 QAM, 2/3 code rate)									
$\Delta F$ = Centre frequency of T-DAB minus centre frequency of DVB-T									
$\Delta F$ (MHz)	-4,5	-3,7	-3,5	-2,5	0	2,5	3,5	3,7	4,5
PR	-30	-6	-5	28	29	28	-5	-6	-30

### 9.3.1.6 T-DAB interfered with by DVB-T

**Table 39: Protection ratios (dB) for T-DAB interfered with by DVB-T 8 MHz**

DVB-T 8 MHz (ITU Mode M3, 64 QAM, 2/3 code rate)									
$\Delta F$ = Centre frequency of DVB-T minus centre frequency of T-DAB									
$\Delta f$ (MHz)	-5	-4,2	-4	-3	0	3	4	4,2	5
PR	-50	-1	0	1	1	1	0	-1	-50

**Table 40: Protection ratios (dB) for T-DAB interfered with by DVB-T 7 MHz**

DVB-T 7 MHz (ITU Mode M3, 64 QAM, 2/3 code rate)									
$\Delta F$ = Centre frequency of DVB-T minus centre frequency of T-DAB									
$\Delta F$ (MHz)	-4,5	-3,7	-3,5	-2,5	0	2,5	3,5	3,7	4,5
PR	-49	0	1	2	2	2	1	0	-49

## 9.3.2 Procedures for the protection of analogue TV services

This subclause is applicable to both assignment and allotment planning for digital TV. In either case, before a channel is chosen for a digital TV service, it is necessary to establish the size of the analogue coverage area for each station and channel in use (or planned and fully co-ordinated).

To calculate the coverage area of an analogue TV station, two elements are necessary:

- the parameters particular to an individual transmitting station (co-ordinates, height of the antenna, radiated power, etc.) which are used to calculate the wanted signal;
- the system parameters such as the minimum wanted field strength and the protection ratios which are used to calculate the individual nuisance fields. With the appropriate method of combination of these individual nuisance fields, the usable field strength can be calculated.

It is the usable field strengths calculated for different test points at the edge of the coverage area which are used to decide if a new transmitter can be accepted without any further calculation. In practice, the maximum increase of the usable field strength caused by the new transmitter is calculated and the new transmission is accepted if this increase is below an agreed value.

### 9.3.2.1 Establishment of the size of analogue TV coverage areas

Because a certain amount of iteration is involved, the analogue coverage areas are determined in three stages and reference should be made to figures 16 and 17 for clarification of the following texts.

#### **Calculation of noise limited coverage area (minimum wanted field strength)**

In the first stage, using ITU-R Recommendation R.370 [17], the noise-limited service area is found, which is the area that could be served if there were no interference. It may be approximated on the basis of 36 radii, at 10 degree intervals, starting at true north. Where known, the HRP of the transmitting antenna and individual values of height above mean terrain should be taken into account.

#### **Identification of interferes**

In the second stage, the impact of co-channel and adjacent-channel interference from other analogue transmitters is calculated for each wanted station. First, the sub-set of possible interferes is established. This consists of the stations which can produce a nuisance field which is no more than 12 dB below the minimum (usable) field-strength at worst-case locations. This corresponds to an interference increase of 0,5 dB (power sum method) but adds a small safety margin because the identification of the, so-called, worst-case locations is subject to a certain degree of approximation.

#### **Calculation of interference limited coverage area**

The nuisance field-strength from each of the interfering stations in this sub-set is calculated at each of the 36 points around the periphery of the service area of the wanted station. (That is, at the service radius on each of the 36 bearings described above). These calculations include the relevant protection ratio values and the value of any receiving antenna discrimination. The power sum of these nuisance field-strengths is found for each of the 36 points. These power sums represent the total interference at each of the 36 points.

If the power sum at a point is less than the minimum wanted field strength, no further calculation is required and the coverage radius is that of 1 above.

If the power sum at a point is greater than the minimum wanted field strength, it is then necessary to find the new radius at which the field-strength from the wanted station equals the sum of the nuisance fields.

Because, in general, the coverage radius thus calculated will not equal the service radius on the same bearing and thus the nuisance field-strengths will change, the process of the previous paragraph is repeated to obtain a close approximation to the required coverage radius on each of 36 bearings.

The process described above is repeated for each transmitter on a given channel and is also repeated for all UHF channels.

**NOTE:** A given analogue station will normally have different coverage areas on different channels and this can be important when considering the relative coverage of digital and analogue services.

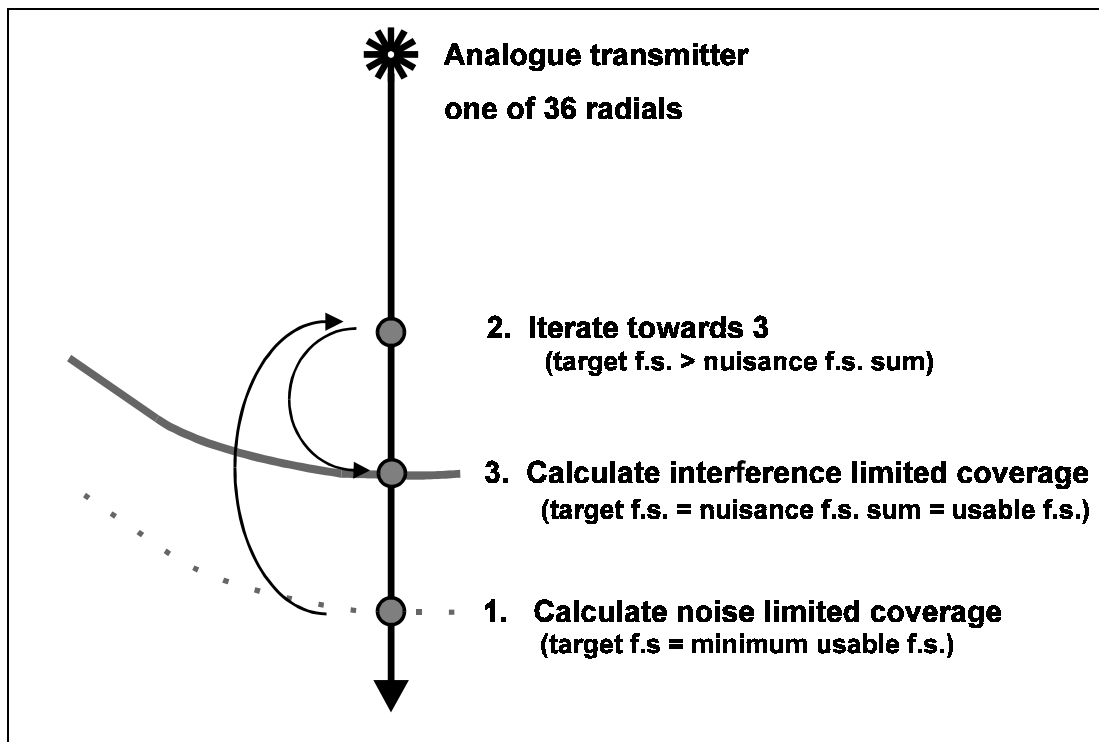

Figure 16: Calculation of test points for the analogue interference limited coverage

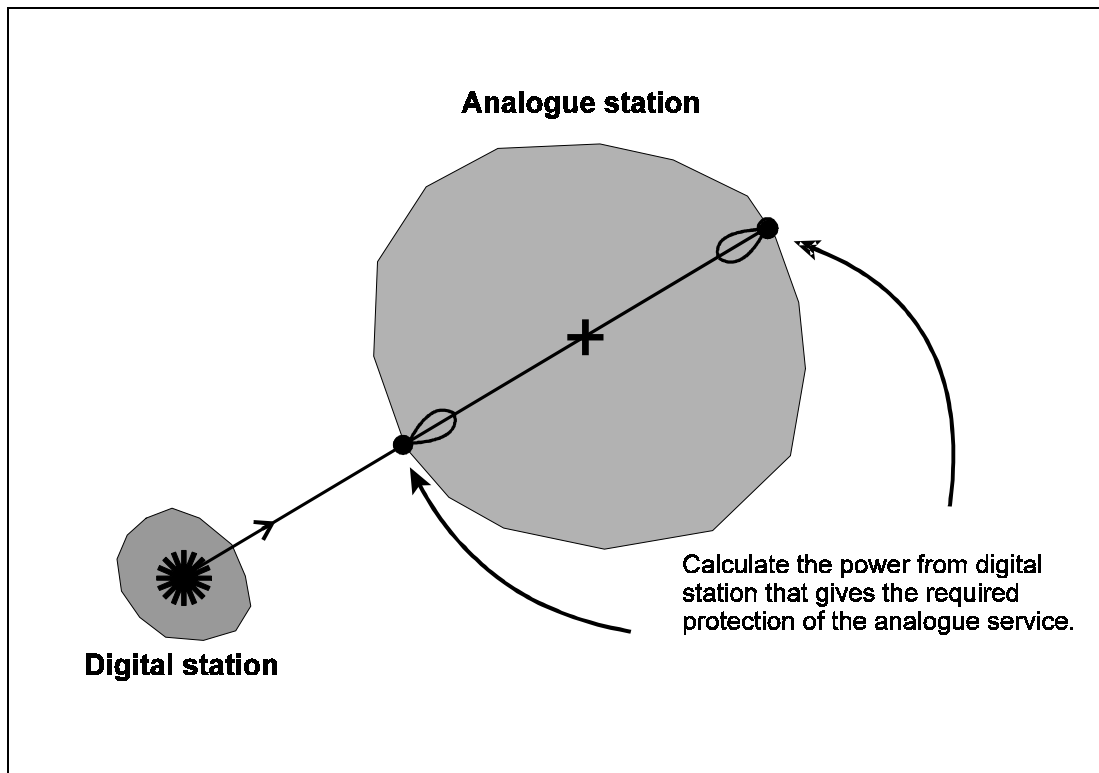

Figure 17: Calculation of digital TV coverage

### 9.3.2.2 Protection on national boundaries

In some cases, for example where there are no existing or planned analogue services to be protected, it may be desirable to establish a set of test points, for the purpose of calculation of potential interference, along the boundary of a country. Agreements will need to be reached on the criteria needed for the establishment of such test points and the ways in which they may be used.

### 9.3.3 Protection of other services

A number of sharing situations exist and these vary from one country to another, both in terms of the "other service" involved and its status in radio regulatory terms. The calculation process will need to consider both assignments and allotments as the basis for digital TV planning.

A calculation should be made at each of the calculation test points used in the definition of the other service. This calculation should take into account:

- the signal level to be protected at each of the test points;
- receiving antenna discrimination (polarization and directivity), where relevant;
- the protection ratio for the frequency difference between the other service and the interfering signals;
- the signal level from the interfering transmitter.

From the above information, the protection margin (at each test-point) may be calculated for the other service. These margins may be used to provide guidance during any necessary co-ordination discussions.

The calculation of the interfering signal level is dependent upon the other service being considered. ITU-R Recommendation R.370 [17] may be used for terrestrial other services, taking into account the relevant % of time for which protection is needed. However, the relevant ITU-R Recommendation should be used to calculate the interfering field strength for aeronautical (or satellite) services.

### 9.3.4 Protection of previously co-ordinated digital TV services

In the context of a planning conference, the coverage area to be protected should be taken to be the area within the set of boundary test-points used in the definition of the assignment. The target for protection should be 99 % time and 95 % of locations either for fixed antenna or portable reception (although the protection and coverage criteria for portable reception may need to be reviewed).

A comparison between the size of a digital station coverage area and the area defined by the requirement may be used to provide guidance during any co-ordination process at planning conference or during bi-lateral or multi-lateral co-ordination meetings.

It is recommended that this is carried out in a similar way to the protection of analogue services, that is by the calculation of a "reference coverage area" as defined by a set of test points. In an international co-ordination process the impact of a new transmission on this coverage area can be evaluated and a decision can be made on the possibility to accept this new transmission.

Whilst it may be possible to plan for a number of digital system variants, which could change from day to day or even during the day, it is recommended that only one system variant should be used for co-ordination in order to avoid unnecessary complications. It may be necessary for a planning conference to decide on the digital system variant for which planning is undertaken in order to provide for equality of opportunity for all countries participating in the conference.

---

## History

<b>Document history</b>		
V1.1.1	December 1997	Publication