

**Environmental Engineering (EE);
Transient voltages at Interface "A"
on telecommunications
direct current (dc) power distributions**



Reference

RTR/EE-02013

Keywords

power supply, protection, transient

ETSI

650 Route des Lucioles
F-06921 Sophia Antipolis Cedex - FRANCE

Tel.: +33 4 92 94 42 00 Fax: +33 4 93 65 47 16

Siret N° 348 623 562 00017 - NAF 742 C
Association à but non lucratif enregistrée à la
Sous-Préfecture de Grasse (06) N° 7803/88

Important notice

Individual copies of the present document can be downloaded from:

<http://www.etsi.org>

The present document may be made available in more than one electronic version or in print. In any case of existing or perceived difference in contents between such versions, the reference version is the Portable Document Format (PDF). In case of dispute, the reference shall be the printing on ETSI printers of the PDF version kept on a specific network drive within ETSI Secretariat.

Users of the present document should be aware that the document may be subject to revision or change of status. Information on the current status of this and other ETSI documents is available at

<http://portal.etsi.org/tb/status/status.asp>

If you find errors in the present document, send your comment to:

editor@etsi.fr

Copyright Notification

No part may be reproduced except as authorized by written permission.
The copyright and the foregoing restriction extend to reproduction in all media.

© European Telecommunications Standards Institute 2002.
All rights reserved.

DECT™, **PLUGTESTS™** and **UMTS™** are Trade Marks of ETSI registered for the benefit of its Members.
TIPHON™ and the **TIPHON logo** are Trade Marks currently being registered by ETSI for the benefit of its Members.
3GPP™ is a Trade Mark of ETSI registered for the benefit of its Members and of the 3GPP Organizational Partners.

Contents

Intellectual Property Rights	4
Foreword.....	4
1 Scope	5
2 References	5
3 Definitions, symbols and abbreviations	5
3.1 Definitions	5
3.2 Symbols.....	5
3.3 Abbreviations	6
4 Void.....	6
5 Typical power distribution	6
6 Characteristics of a power fault transient	7
7 The transient, part 1.....	7
8 Analysis of part 1	8
8.1 Increasing distribution resistance	9
8.2 Decreasing the fault clearance time.....	9
8.3 Decreasing power distribution inductance	10
8.3.1 Calculating inductance.....	10
8.3.2 Measuring inductance	11
8.4 Summary	11
8.5 Recommendations	11
9 The transient, part 2.....	11
10 Analysis of part 2	12
10.1 Absorbing the energy	12
10.2 Dissipating the energy	13
10.3 Recommendations	13
11 Testing for immunity to transients	14
11.1 Transient immunity test circuit; by applying real power distribution to an installation model (high power systems).....	14
11.2 Transient immunity test circuit; by analogue circuit simulation (suggestion 1).....	15
11.3 Transient immunity test circuit; by analogue circuit simulation (suggestion 2).....	16
12 Conclusion.....	18
History	19

Intellectual Property Rights

IPRs essential or potentially essential to the present document may have been declared to ETSI. The information pertaining to these essential IPRs, if any, is publicly available for **ETSI members and non-members**, and can be found in ETSI SR 000 314: *"Intellectual Property Rights (IPRs); Essential, or potentially Essential, IPRs notified to ETSI in respect of ETSI standards"*, which is available from the ETSI Secretariat. Latest updates are available on the ETSI Web server (<http://webapp.etsi.org/IPR/home.asp>).

Pursuant to the ETSI IPR Policy, no investigation, including IPR searches, has been carried out by ETSI. No guarantee can be given as to the existence of other IPRs not referenced in ETSI SR 000 314 (or the updates on the ETSI Web server) which are, or may be, or may become, essential to the present document.

Foreword

This Technical Report (TR) has been produced by ETSI Technical Committee Environmental Engineering (EE).

1 Scope

Short duration transient disturbances can occur on dc power distributions when a short circuit fault occurs in part of that distribution. The energy contained in the transient can be sufficient to do considerable damage to equipment connected to the distribution unless measures are taken to suppress or absorb this energy.

The present document examines the parameters of dc power distributions within the scope of EN 300 132-2 [1] that significantly contribute to the energy contained by a transient, discusses ways in which the transient can be controlled to reduce its harmful effects, and suggests ways in which the immunity of an electronic unit or a substantial telecommunications installation might be tested.

2 References

For the purposes of this Technical Report (TR) the following reference applies:

- [1] ETSI EN 300 132-2: "Environmental Engineering (EE); Power supply interface at the input to telecommunications equipment; Part 2: Operated by direct current (dc)".

3 Definitions, symbols and abbreviations

3.1 Definitions

For the purposes of the present document, the following terms and definitions apply:

fault: short circuit of the negative conductors of the power distribution to any earthed part of an equipment or installation

Interface "A": The definition given in EN 300 132-2 [1] applies.

3.2 Symbols

For the purposes of the present document, the following symbols apply:

A	Ampere
C	Capacitance
d	separation of conductors
dc	direct current
E	Energy
I	current
L	inductance
l	length of conductor
n	number of ways current is split
r	diameter of conductor
R	Resistance
t	time
U	voltage (nominal voltage)
V	voltage (overvoltage)
μ	magnetic permeability of insulation separating conductors

3.3 Abbreviations

For the purposes of the present document, the following abbreviations apply:

EUT	Equipment Under Test
PDF	Power Distribution Frame
U_B	Battery voltage

4 Void

5 Typical power distribution

Virtually all equipment operated in telecommunications centres has a battery as a backup source of power in the event of a mains failure. Batteries store very large amounts of energy and under fault conditions are able to deliver very large currents for short periods far in excess of the ratings of fuses or circuit breakers in the path of the fault.

Figure 1 shows a typical power distribution (negative conductors only) in a large installation. The current supplied from the power plant and battery is broken down into several lower current feeds at each Power Distribution Frame (PDF). The power cables are sized according to the current they have to carry and the voltage drop that can be tolerated, and are protected by suitably rated fuses or breakers in each PDF. In large installations the conductors close to the battery may be copper or aluminium bus bars.

The positive return conductors will be parallel with the negative conductors but will not include current protection devices.

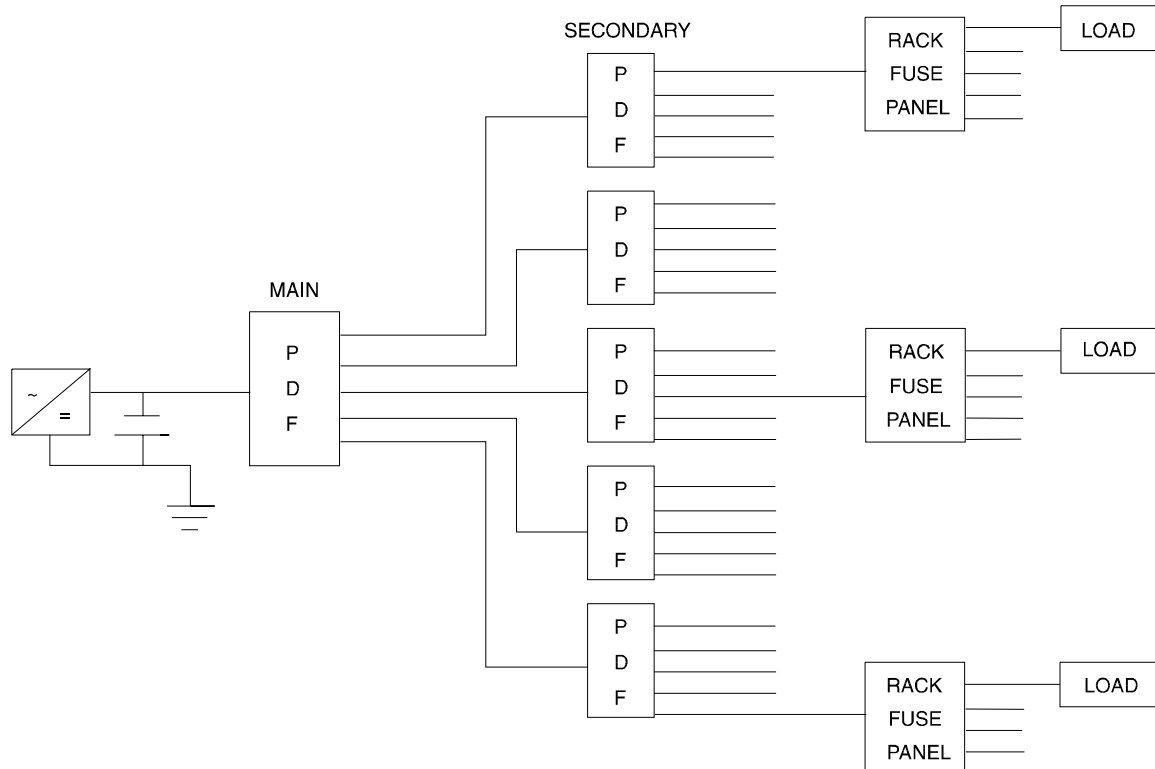

Figure 1: Typical power distribution

6 Characteristics of a power fault transient

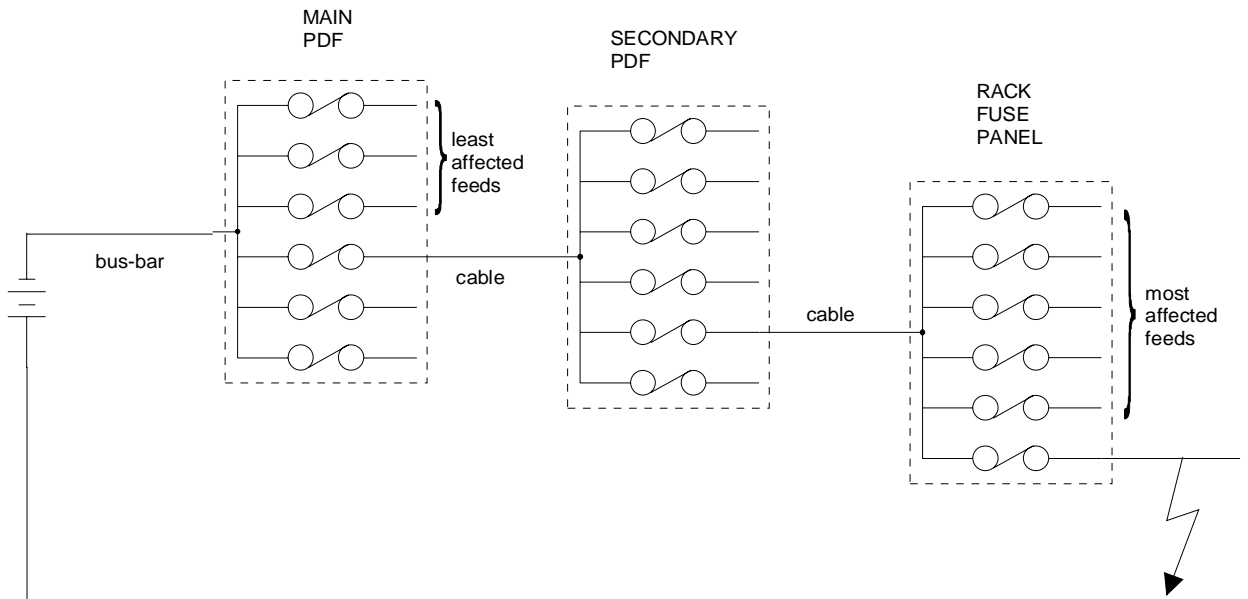

Figure 2: Power fault applied in an equipment rack

Figure 2 shows the fault current path when a fault occurs in a branch of the power distribution. The voltage transient experienced by the branches of the distribution not associated with the fault can be divided into two distinct parts and are shown in figures 4 and 5:

- Part 1 - begins at the moment the fault is applied (t_0) and ends at the instant the protection device clears (t_1);
- Part 2 - begins at the instant the protection device clears the fault (t_1), and ends (t_2) when the voltage returns to its value before the fault was applied.

7 The transient, part 1

When the fault is applied the current rises rapidly at an exponential rate:

$$I = \frac{U_B}{R} (1 - e^{-\frac{R}{L}t}) \quad (1)$$

Where:

- U_B = the battery voltage in float mode.
- R = the sum of the resistances in the fault circuit which include:
 - (a) fault resistance itself;
 - (b) total conductor resistance in both negative and return legs;
 - (c) the resistance of fuses or breakers;
 - (d) the internal resistance of the battery.
- L = the inductance of the fault circuit loop.
- t = the time elapsed from the fault being applied.

It can be seen that if inductance is ignored, the potential fault current can be extremely high.

$$I = \frac{U_B}{R} \quad (2)$$

Currents of in excess of 1 kA are not unusual, depending on where the fault occurs in the distribution.

In practice the inductance of the fault circuit cannot be ignored and it plays an important role in the behaviour of the power distribution as will be seen next.

8 Analysis of part 1

Two things are of concern during this part of the fault transient:

- a) the magnitude of the fault current;
- b) the voltage at the input of all other equipment sharing the same power distribution.

The magnitude of the fault current largely determines the amount of energy that must be dissipated after the fault is cleared by the protection device.

$$E = 1/2 LI^2 \quad (3)$$

where:

- E is the energy (joules);
- L is the inductance of the fault circuit (henrys);
- I is the fault current at the instant the fault is cleared by the protection device (amps).

The voltage at the input of all other equipment sharing the same distribution falls to below the normal, minimum steady state value for some portion of the clearing time of the protection devices, requiring the dc/dc converters to store charge on "hold up" capacitors to ride through this fall in supply voltage. The magnitude and duration of the fall depends on many parameters of the power distribution already mentioned e.g. R, t_1 and L. How these can be controlled is explained in clauses 8.1, 8.2 and 8.3.

The general objective must be to reduce the energy stored in the distribution inductance which from equation 1 means that the distribution inductance itself (L) must be kept to a minimum and the peak fault current (I) must be controlled by resistance in the distribution (R) or by the use of very short clearance time fuses (t_1).

8.1 Increasing distribution resistance

Resistance would seem to be an undesirable feature to have in a power distribution but used in the right way, there are advantages worth having by its inclusion that more than compensate for the power losses.

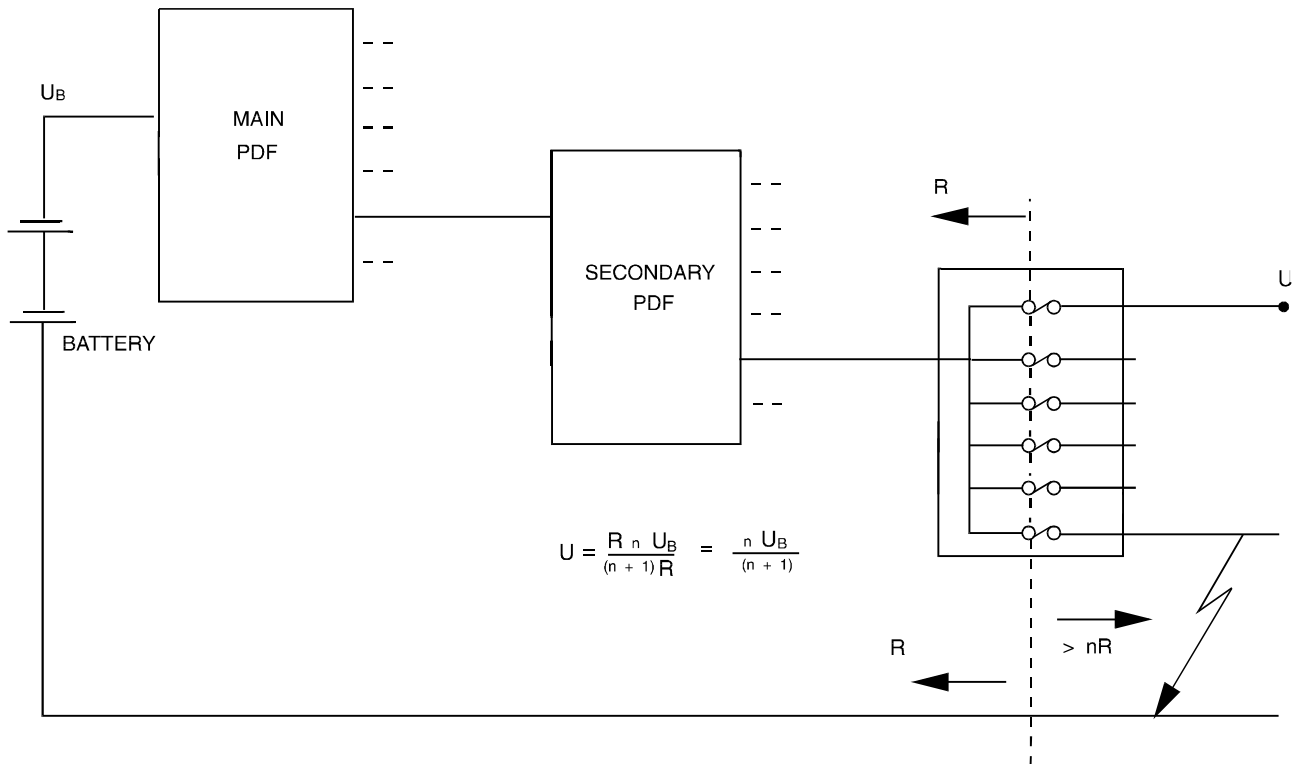

Figure 3: A controlled resistive power distribution

Figure 3 shows a power distribution where the resistance has been concentrated in the most remote branches. The fault current is limited to:

$$I = \frac{U_B}{(n+1)R} \quad (4)$$

But the voltage supplied to the other rack power feeds can be reasonably expected to remain above:

$$U = \frac{nU_B}{1+n} \quad (5)$$

after the influence of inductance in the circuit has passed. If dc/dc converters are designed to operate at U volts, only the drop in voltage due to circuit inductance needs to be covered by "hold up" capacitors in the converters. Such a resistive power distribution permits the use of circuit breakers, with their longer clearance times compared to fuses, and at the same time, there is no need to increase the hold up time of the power converters to match the clearance time of breakers.

8.2 Decreasing the fault clearance time

The response of fuses and circuit breakers to fault currents needs to be understood.

A fuse needs time to break an excessive current i.e. a current greater than its rated value. The larger the excess current the sooner the fuse element reaches its melting point and ruptures. However, even with very high levels of excess current, a fuse will still have a finite clearance time. Depending on the design of the fuse and the excess current level, clearance times can vary from 1 ms to more than 10 ms.

Circuit breakers have a rather different response to large fault currents. The time needed to clear an excessive current is mainly dependent on the inertia of the moving mass of the breaker mechanism and contacts. The range of clearance times for breakers is usually longer than for fuses, the fastest being 4 ms to 6 ms and the longest extending beyond 15 ms.

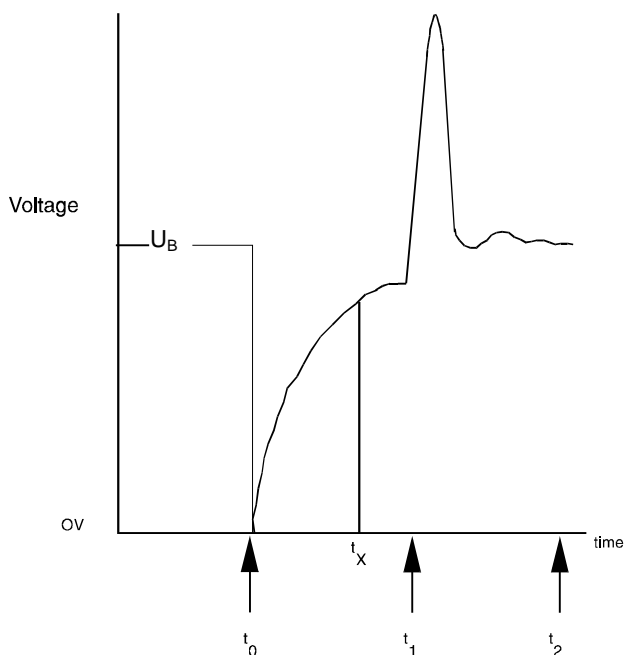

Figure 4: Voltage transient waveform

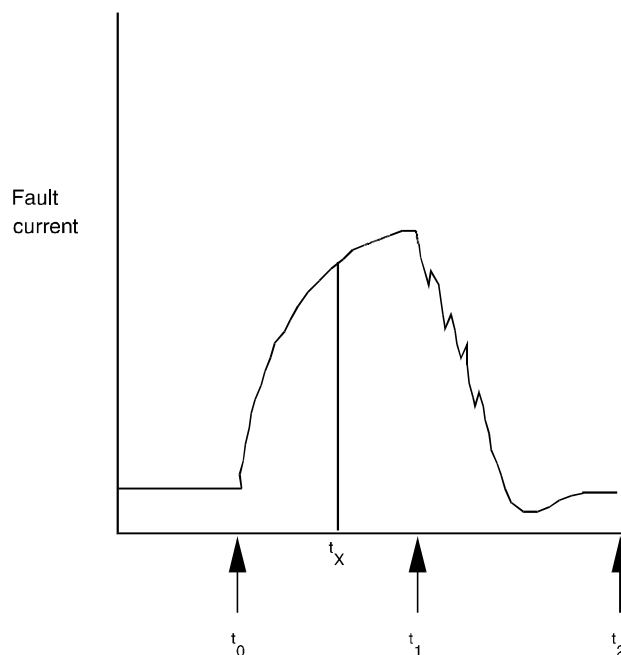

Figure 5: Current transient waveform

The importance that these overcurrent protection devices play can be seen in the diagrams of figures 4 and 5 when coupled to the inductance present in the fault circuit. The fault current rises exponentially towards the maximum level already established in equation (2) above, and, depending on the clearance time of the protection device (t_x or t_1 in figures 4 and 5, battery in float mode U_B) being used, the peak fault current may be limited by the inductance of the fault loop. If the clearance time is long, then the peak current is limited only by the resistance of the fault loop.

8.3 Decreasing power distribution inductance

8.3.1 Calculating inductance

The inductance of any fault circuit is reduced when all the negative conductors are closely coupled to the earth return conductors, the closer the coupling the less inductance there is.

Negative and return conductors made as a bonded pair (e.g. twin cables) provide a good solution with consistent performance figures for inductance per metre length. If this is not possible, then separate conductors run side by side as closely as possible gives good results, or negative conductors tied at frequent intervals to a positive return bus-bar also reduces distribution inductance.

The theoretical equation for the inductance (L) of a pair of parallel conductors is shown below:

$$L = l \times \frac{\mu}{\pi} \ln \frac{d}{r} \quad (6)$$

Where:

- r = the diameter of the conductors;
- d = the separation of the conductor centres;
- μ = the magnetic permeability of the insulation that separates the conductors;
- l = the length of conductor.

This equation is only approximately correct as it assumes that "d" is much greater than "r" which is not true of a pair of power conductors.

8.3.2 Measuring inductance

A more accurate method of characterizing the inductance of a conductor pair is by direct measurement. This can be done using a representative length of bonded pair cable, shorting the two conductors at one end and measuring the inductance at the other end. As the low frequency inductance is the parameter that stores energy when fault currents flow in the cables, the measuring frequency should be the minimum that permits a dependable reading from the measuring instrument. Higher measuring frequencies will give erroneous readings due to distributed cable capacitance between conductors and from each conductor to its surroundings. Measurements can also be made on an installation during construction or before power is connected.

8.4 Summary

Figure 4 shows a typical transient caused by a fault, as seen at the input to a branch sharing the same secondary PDF, or the same rack fuse panel, as the branch with the fault.

The initial large drop in voltage is caused by inductance in those parts of the fault circuit that are shared with the branch being monitored, and the duration is dependent on the value of the inductance. If it is small then the voltage quickly recovers to the value determined by the distribution of resistance in the cabling from the battery to the point of application of the fault (see figure 3). If it is large then the fault current may not reach the value limited by resistance alone before the fuse clears the fault circuit (see figure 5). The time constant for the inductively controlled part of the voltage dip can vary from a few tens of microseconds to perhaps 2 ms.

Where it is not possible to reduce distribution inductance, the fault current can be reduced using fuses with very short clearance times.

When the design of the whole power distribution can be undertaken, the apportioning of resistance by the selection of cable sizes or other means can both reduce the fault current and reduce the voltage drop for that portion of the wave form controlled by resistance to a value that still permits the normal operation of dc/dc converters.

8.5 Recommendations

If Interface "A" for a particular installation occurs at a remote point in the power distribution then there is little that can be done to influence the magnitude or duration of the voltage dip, and it would be safest for a supplier of equipment to assume that the voltage drops to an unusable level for the duration of the clearing time of the protective devices. The supplied equipment would at the same time need to be designed to give continuous service during the clearing of the types of fuses or circuit breakers being used on that location. The dc/dc converter's specification for "hold up" time will need to match the clearing time.

If the interface is at a point closer to the battery, then the scope for the equipment's own power distribution to adopt some of the measures already outlined is much greater. The use of apportioned resistance in the distribution has the advantage that it allows the use of circuit breakers as the protective device, which is favoured by most network operators today, and the "hold up" time needed by the dc/dc converters only needs to cover the inductive portion of the voltage dip.

9 The transient, part 2

The second part of the transient begins at t_1 (see figures 4 and 5) when the protection device opens the fault circuit while the fault current is at its peak. With the fault circuit now open, there is much more current flowing in the inductance of the cables than is required by the combined load of the affected branches. The energy represented by this excess current and the cable inductance (see equation 1) must be encouraged to decay without causing damage to any equipment connected to the power distribution.

10 Analysis of part 2

The analysis of part 1 has shown how energy is stored in the conductors of the power distribution, and how this energy can be kept to a minimum, but the energy that remains can be disposed of in two ways:

- a) by absorbing it and gently releasing it to the load;
- b) by dissipating it as heat.

10.1 Absorbing the energy

The energy can be absorbed by capacitance distributed across the power distribution. This can be in the form of capacitor banks placed in PDFs and rack fuse panels, or it can be in the form of the capacitors that exist at the input to dc/dc converters to provide "hold up" time during part 1 of the transient, or a combination of both.

To give an indication of the amount of capacitance needed to keep the rise in voltage below a given value, the following relationships can be used:

$$\frac{1}{2}LI^2 = \frac{1}{2}CV^2 \quad (7)$$

$$C = \frac{LI^2}{V^2} \quad (8)$$

Where V is the overvoltage i.e. the rise in voltage above the supply voltage. Thus if LI^2 has been minimized, then for a given value of V the equipment can tolerate, C is the amount of capacitance needed to control the overvoltage.

Alternatively, for a given value of distributed capacitance (C), V is the over-voltage:

$$V = \sqrt{LI^2/C} \quad (9)$$

Again this should only be used as a guide because not all the energy is transferred to the capacitance due to resistive losses in cables and in the capacitors themselves.

Figure 6 curve (a) shows a transient between times t_1 and t_2 that would not be acceptable on a power distribution, which has been transformed by distributed capacitance to figure 6 curve (b) which could be tolerated by most equipment.

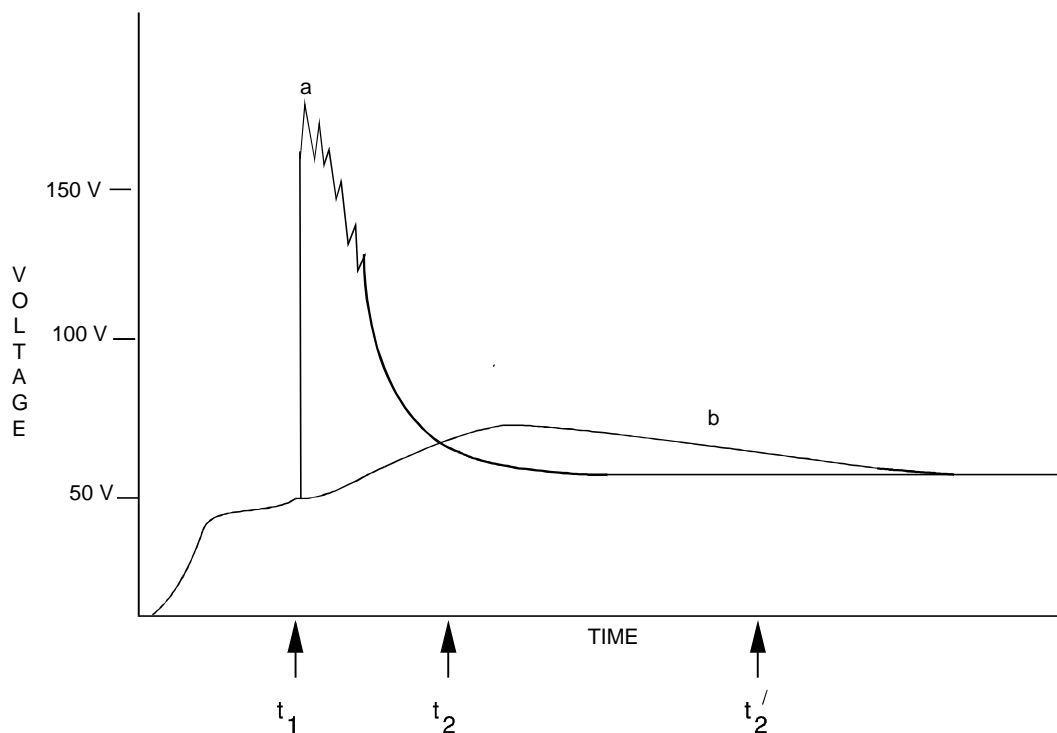

Figure 6: Alternative transient recovery waveforms; curve a and curve b

10.2 Dissipating the energy

The energy can be dissipated quickly by using transient absorbing devices which are essentially like Zener diodes connected across the positive and negative conductors at a number of strategic points in the distribution. The transient absorbing device is chosen to conduct at a voltage safely above the maximum continuous voltage of the power system, and safely below the voltage at which damage might occur to the equipment. These devices need to be rated for very high peak powers.

Alternatively, there are fuses and breakers that are specifically designed to produce an arc as the fuse element melts or the breaker contacts separate. These can go a long way to being able to dissipate the excess energy on their own. They are often backed up by lower powered Zener diodes to guard against premature extinguishing of the arc.

10.3 Recommendations

The capacitive solution works very well but the consequences of a short circuit failure of such large capacitors, protected by only high current rated fuses or breakers, needs to be considered carefully.

The Zener diode solution also can be successful, but the tolerance on the Zener voltage often makes it difficult to meet the conditions given in clause 10.2.

Arcing fuses and breakers are relatively new but deserve serious consideration.

11 Testing for immunity to transients

Dependent upon the size of the installation needing to be tested, there are two practical and one theoretical means of demonstrating immunity to power transients:

- a) By simulating a transient, suitable in scale and energy to the size of the equipment being tested.

To do this the power distribution to which the equipment under test will be connected needs to be known in some detail or some form of worst case distribution assumed. The maximum energy available, the equivalent resistance and capacitance of other loads connected to the same distribution, and any voltage limiting devices present in the distribution would all need to be represented in the transient simulating circuit used for this test.

- b) By applying real power distribution faults to an installation model.

For large installations or where a large part of the power distribution is supplied with the equipment, this is by far the best way of demonstrating transient immunity.

- c) By analogue circuit simulation of the whole power distribution under an applied fault and including the extreme limits of the results in the specification of the dc/dc converters or other direct load circuits.

The accuracy and validity of the results depends on the integrity of the data used in the simulation. Simulations of this nature usually need some practical testing to give credibility to the results.

11.1 Transient immunity test circuit; by applying real power distribution to an installation model (high power systems)

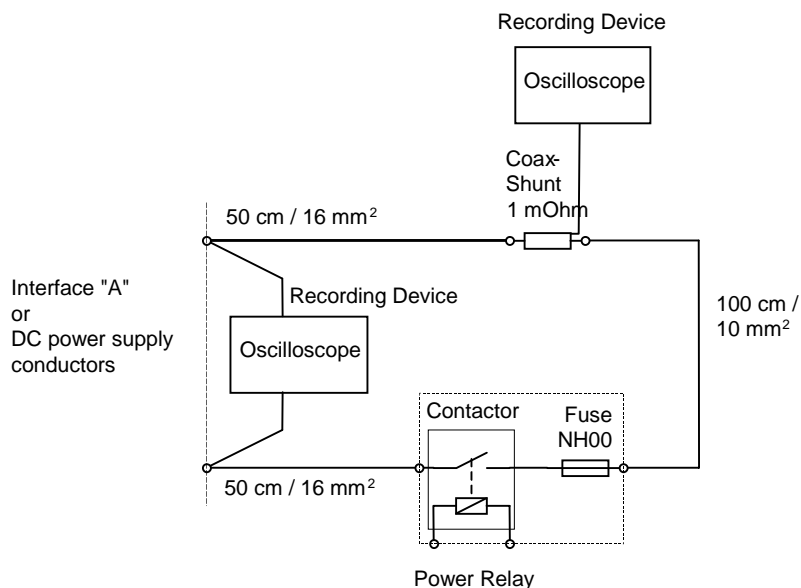

Figure 7: Test set-up for a method for testing high power systems (e.g. more than 1 kW)

Fuse rating has to be determined on DC power supply equipment with distribution and protection, DC power supply conductors or Interface "A".

11.2 Transient immunity test circuit; by analogue circuit simulation (suggestion 1)

Figure 8 provides a suggested circuit for creating the levels of energy and current that can be found in a faulted distribution. With the values shown, the circuit provides a 4 ms drop in voltage while developing a fault current of 300 A, followed by the release of 10 J of energy.

The inductance in the test circuit L_1 may be varied to suit the conditions in any power distribution at any position of Interface "A". Similarly the peak current can be varied by the adjustment of R_1 , R_x and R_s .

The diodes D_1 and D_2 are included only to limit the maximum voltage generated to a safe level when the equipment under test has low capacitance.

The test is only valid if the diodes do not conduct significantly during the test i.e. less than 3 A. Conduction of the diodes indicates that not all of the energy is being injected at the interface.

If required, the Zener diode voltage of D_2 can be varied to match the voltage immunity of the equipment under test, and to avoid diode conduction.

The nodes marked A represent Interface "A". At this point can be connected the equivalent circuit of other loads that may be connected to the same Interface "A" as the Equipment Under Test (EUT).

L_2 and R_2 represent the power distribution from Interface "A" to the equipment under test.

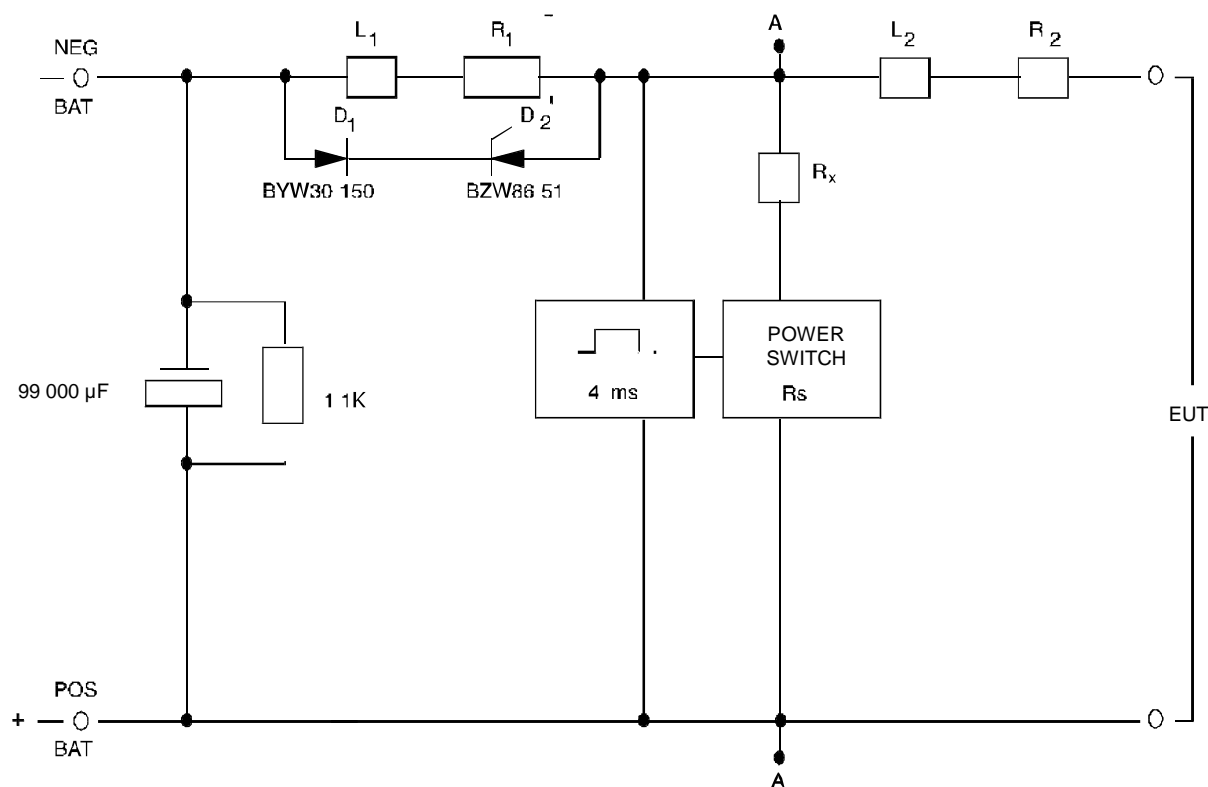

NOTE: The nodes marked A represent Interface "A".

Figure 8: Transient immunity test circuit

11.3 Transient immunity test circuit; by analogue circuit simulation (suggestion 2)

Figure 9 gives a circuit description of an alternative voltage transient generator for Interface "A".

The circuit generates a voltage transient with a maximum energy of 2 to 10 J which can be absorbed by a load connected to Interface "A".

Table 1: Technical data of the generator

Version (max. energy)	2 J	10 J
maximum peak voltage	150 V	150 V
rise time 30/90 %	100 μ s	100 μ s
50 % fall time	300 μ s	300 μ s
peak output current	170 A	1700 A

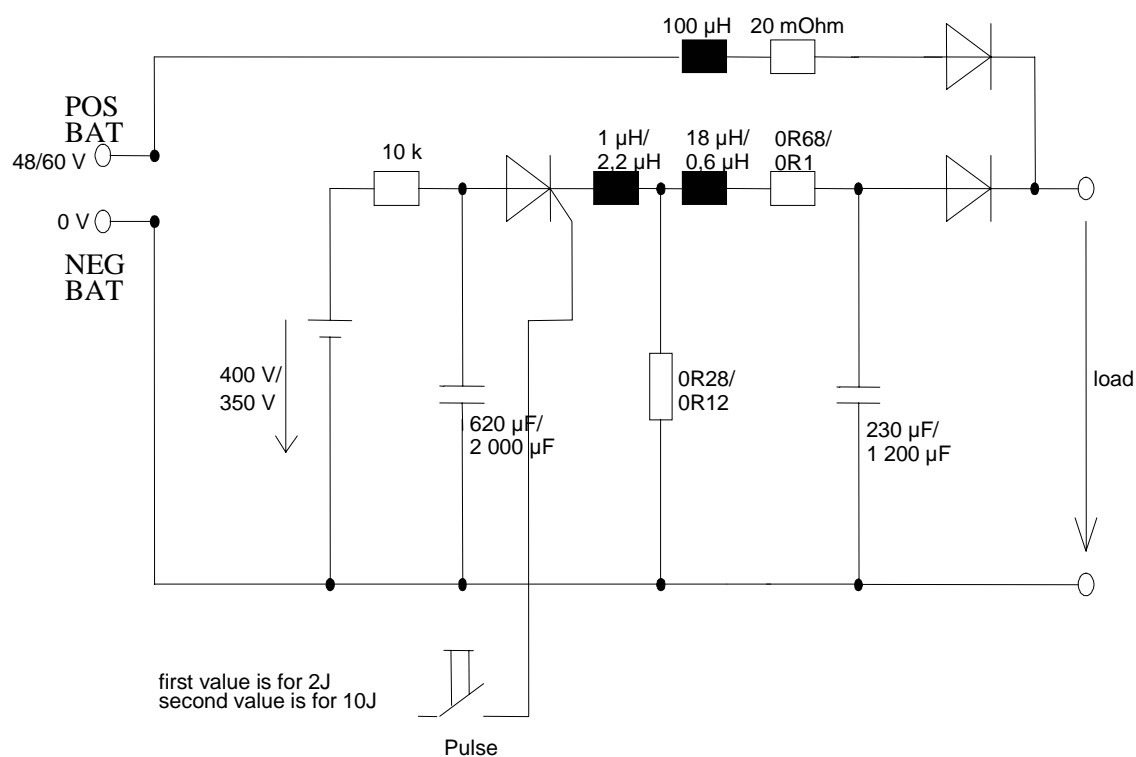

Figure 9: Alternative voltage transient generator for Interface "A"

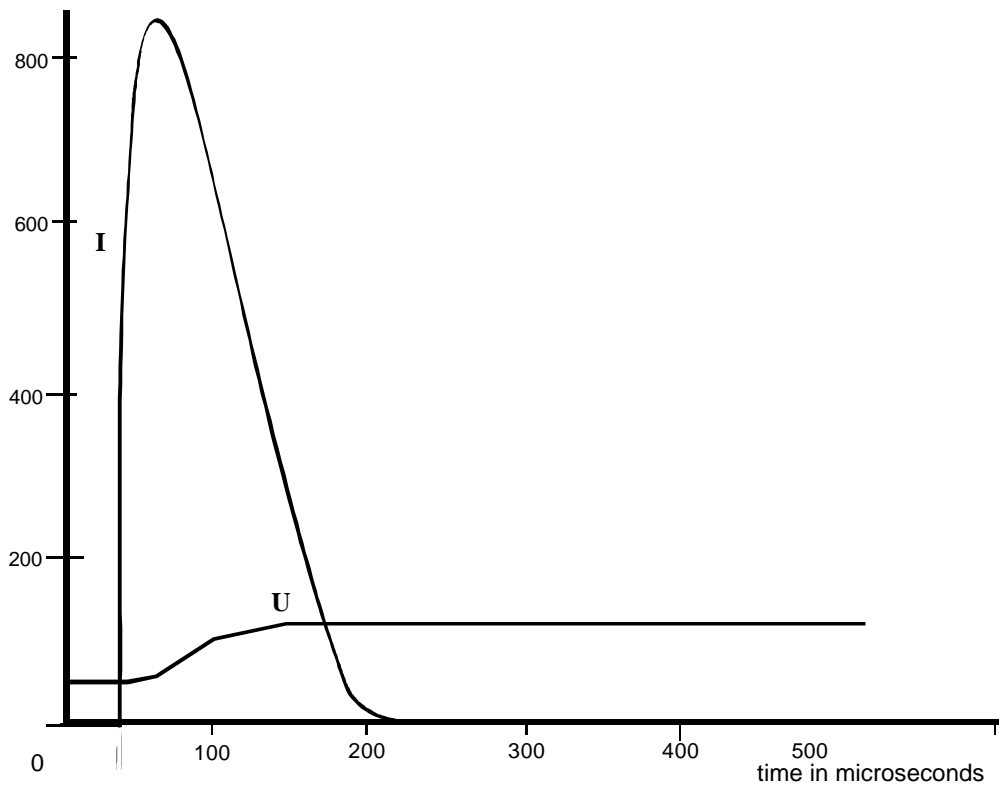

Figure 10: Output voltage and current with 100 Ω / 1 000 μF load (10 J)

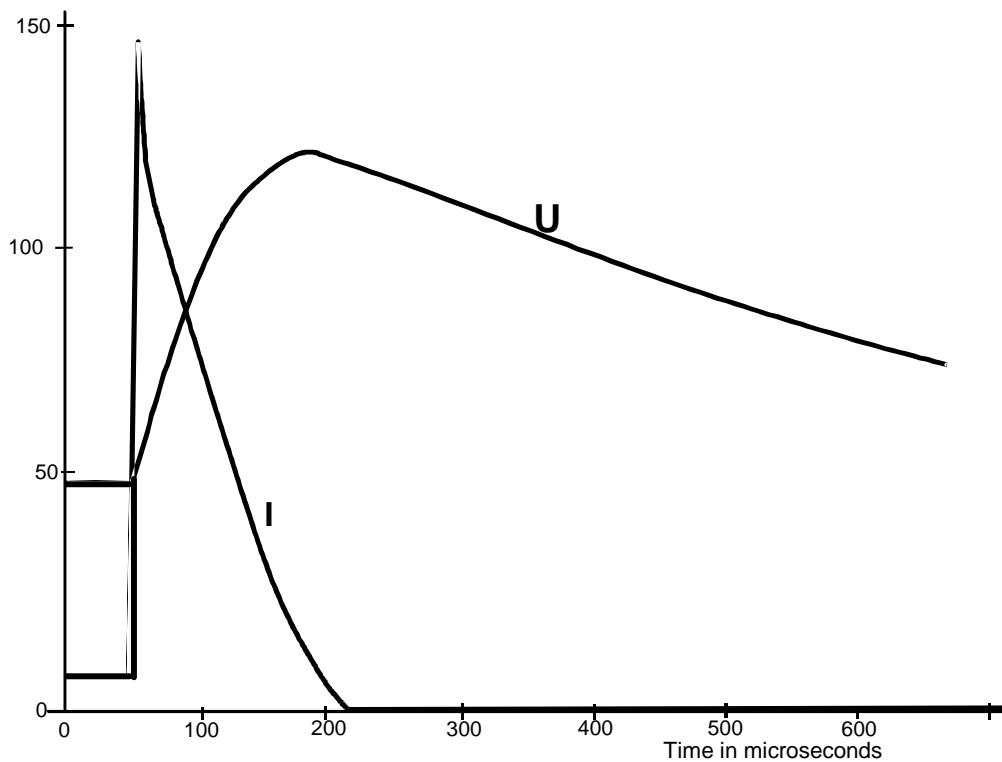

Figure 11: Output voltage and current with 10 Ω / 100 μF load (2 J)

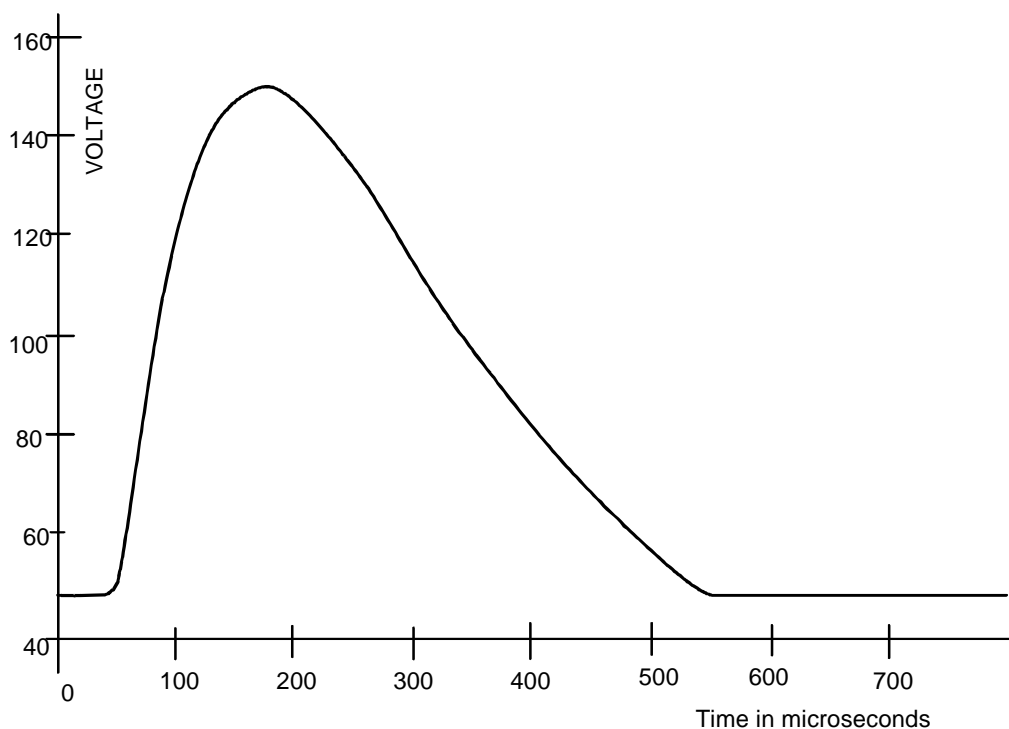

Figure 12: Output voltage with 100 kΩ load (both versions)

12 Conclusion

The present document has shown that no standard can be applied to a transient that appears on a power distribution. The energy stored in the cables of a distribution network depends on many factors, several of which may not be under the control of an equipment supplier. If Interface "A" for a large installation is close to the battery then there is the opportunity to design the power distribution and the equipment itself to work together to achieve immunity to power faults by applying the principles contained in the present document.

Recognizing this difficulty, each installation or extension will need an understanding between network operator and supplier on how compatibility on either side of Interface "A" may be achieved so that all equipment from many suppliers sharing the same power distribution can each tolerate power faults occurring in the other.

The parameters must describe the time voltage relationship of the transient that this equipment will tolerate without deviating from the specified performance.

History

Document history		
Edition 1	May 1996	Publication as ETR 283
Corrigendum 1	March 1997	Corrigendum 1 to 1 st Edition of ETR 283
V2.1.1	July 2002	Publication