

**Electromagnetic compatibility  
and Radio spectrum Matters (ERM);  
Uncertainties in the measurement  
of mobile radio equipment characteristics  
Part 1**

---



---

**Reference**

RTR/ERM-RP02-016-1

---

**Keywords**

Measurement uncertainty, mobile, radio

**ETSI**

---

650 Route des Lucioles  
F-06921 Sophia Antipolis Cedex - FRANCE

Tel.: +33 4 92 94 42 00 Fax: +33 4 93 65 47 16

Siret N° 348 623 562 00017 - NAF 742 C  
Association à but non lucratif enregistrée à la  
Sous-Préfecture de Grasse (06) N° 7803/88

---

**Important notice**

Individual copies of the present document can be downloaded from:

<http://www.etsi.org>

The present document may be made available in more than one electronic version or in print. In any case of existing or perceived difference in contents between such versions, the reference version is the Portable Document Format (PDF). In case of dispute, the reference shall be the printing on ETSI printers of the PDF version kept on a specific network drive within ETSI Secretariat.

Users of the present document should be aware that the document may be subject to revision or change of status. Information on the current status of this and other ETSI documents is available at <http://www.etsi.org/tb/status/>

If you find errors in the present document, send your comment to:  
editor@etsi.fr

---

**Copyright Notification**

Reproduction is only permitted for the purpose of standardization work undertaken within ETSI.  
The copyright and the foregoing restrictions extend to reproduction in all media.

© European Telecommunications Standards Institute 2001.  
All rights reserved.

# Contents

Intellectual Property Rights .....	8
Foreword.....	8
Introduction.....	8
1 Scope.....	10
2 References.....	10
3 Definitions, symbols and abbreviations .....	11
3.1 Definitions .....	11
3.2 Symbols .....	15
3.3 Abbreviations.....	17
4 Introduction to measurement uncertainty.....	18
4.1 Background to measurement uncertainty.....	18
4.1.1 Commonly used terms.....	18
4.1.2 Assessment of upper and lower uncertainty bounds .....	19
4.1.3 Combination of rectangular distributions .....	20
4.1.4 Main contributors to uncertainty.....	22
4.1.5 Other contributors.....	22
4.2 Evaluation of individual uncertainty components .....	23
4.2.1 Evaluation of Type A uncertainties.....	23
4.2.2 Evaluation of Type B uncertainties.....	24
4.2.3 Uncertainties relating to influence quantities.....	24
4.3 Methods of evaluation of overall measurement uncertainty.....	25
4.4 Summary.....	25
4.5 Overview of the approach of the present document .....	26
5 Analysis of measurement uncertainty .....	26
5.1 The BIPM method.....	26
5.1.1 Type A uncertainties and their evaluation .....	27
5.1.2 Type B uncertainties and their evaluation .....	27
5.2 Combining individual standard uncertainties in different units.....	28
5.3 Calculation of the expanded uncertainty values and Student's t-distribution .....	29
5.3.1 Student's t-distribution .....	30
5.3.2 Expanded uncertainties .....	30
5.4 Combining standard uncertainties of different parameters, where their influence on each other is dependant on the EUT (influence quantities).....	31
5.5 Estimate of standard uncertainty of randomness.....	32
5.6 Summary of the recommended approach.....	34
6 Examples of uncertainty calculations specific to radio equipment.....	34
6.1 Mismatch.....	34
6.2 Attenuation measurement .....	35
6.3 Calculation involving a dependency function.....	37
6.4 Measurement of carrier power .....	39
6.4.1 Measurement set-up.....	39
6.4.2 Method of measurement.....	39
6.4.3 Power meter and sensor module .....	40
6.4.4 Attenuator and cabling network.....	41
6.4.4.1 Reference measurement .....	41
6.4.4.2 The cable and the 10 dB power attenuator .....	42
6.4.4.3 The 20 dB attenuator .....	44
6.4.4.4 Instrumentation.....	45
6.4.4.5 Power and temperature influences.....	46
6.4.4.6 Collecting terms .....	46
6.4.5 Mismatch during measurement.....	46
6.4.6 Influence quantities.....	47

6.4.7	Random .....	48
6.4.8	Expanded uncertainty .....	48
6.5	Uncertainty calculation for measurement of a receiver (Third order intermodulation) .....	49
6.5.1	Noise behaviour in different receiver configurations .....	49
6.5.2	Sensitivity measurement.....	50
6.5.3	Interference immunity measurements .....	51
6.5.4	Blocking and spurious response measurements .....	51
6.5.5	Third order intermodulation .....	51
6.5.5.1	Measurement of third order intermodulation.....	51
6.5.5.2	Uncertainties involved in the measurement.....	52
6.5.5.2.1	Signal level uncertainty of the two unwanted signals.....	53
6.5.5.2.2	Signal level uncertainty of the wanted signal.....	54
6.5.5.3	Analogue speech (SINAD) measurement uncertainty .....	54
6.5.5.4	BER and message acceptance measurement uncertainty .....	54
6.5.5.5	Other methods of measuring third order intermodulation .....	55
6.6	Uncertainty in measuring continuous bit streams.....	55
6.6.1	General.....	55
6.6.2	Statistics involved in the measurement .....	55
6.6.3	Calculation of uncertainty limits when the distribution characterizing the combined standard uncertainty cannot be assumed to be a Normal distribution .....	56
6.6.4	BER dependency functions .....	58
6.6.4.1	Coherent data communications .....	59
6.6.4.2	Coherent data communications (direct modulation) .....	59
6.6.4.3	Coherent data communications (sub carrier modulation).....	60
6.6.4.4	Non coherent data communication .....	61
6.6.4.5	Non coherent data communications (direct modulation).....	61
6.6.4.6	Non coherent data communications (sub carrier modulation).....	63
6.6.5	Effect of BER on the RF level uncertainty .....	63
6.6.5.1	BER at a specified RF level .....	64
6.7	Uncertainty in measuring messages.....	67
6.7.1	General.....	67
6.7.2	Statistics involved in the measurement .....	67
6.7.3	Analysis of the situation where the up down method results in a shift between two levels.....	68
6.7.4	Detailed example of uncertainty in measuring messages .....	69
6.8	Examples of measurement uncertainty analysis (Free Field Test Sites) .....	72
6.8.1	Introduction .....	72
6.8.2	Example 1: Verification procedure .....	72
6.8.2.1	Uncertainty contributions: Stage 1: Direct attenuation measurement .....	73
6.8.2.1.1	Contributions from the mismatch components.....	73
6.8.2.1.2	Contributions from individual components .....	76
6.8.2.1.3	Contribution from the random component.....	78
6.8.2.1.4	Summary table of contributory components .....	79
6.8.2.2	Uncertainty contributions: Stage 2: Radiated attenuation measurement .....	79
6.8.2.2.1	Contributions from the mismatch components.....	79
6.8.2.2.2	Contributions from individual components .....	82
6.8.2.2.3	Contribution from the random component.....	88
6.8.2.2.4	Summary table of contributory components .....	89
6.8.2.2.5	Expanded uncertainty for the verification procedure.....	90
6.8.3	Example 2: Measurement of a transmitter parameter (spurious emission).....	90
6.8.3.1	Uncertainty contributions: Stage 1: EUT measurement .....	90
6.8.3.1.1	Contributions from the mismatch components.....	90
6.8.3.1.2	Contributions from the individual components .....	91
6.8.3.1.3	Contribution from the random component.....	96
6.8.3.1.4	Summary table of contributory components .....	97
6.8.3.2	Uncertainty contributions: Stage 2: Substitution measurement .....	98
6.8.3.2.1	Contributions from the mismatch components.....	98
6.8.3.2.2	Contributions from the individual components .....	100
6.8.3.2.3	Contribution from the random component.....	106
6.8.3.2.4	Summary table of contributory components .....	107
6.8.3.2.5	Expanded uncertainty for the spurious emission test.....	107
6.8.4	Example 3: Measurement of a receiver parameter (Sensitivity) .....	108
6.8.4.1	Uncertainty contributions: Stage 1: Transform Factor measurement.....	108

6.8.4.1.1	Contributions from the mismatch components.....	108
6.8.4.1.2	Contributions from the individual components.....	110
6.8.4.1.3	Contribution from the random component.....	116
6.8.4.1.4	Summary table of contributory components.....	117
6.8.4.2	Uncertainty contributions: Stage 2: EUT measurement.....	117
6.8.4.2.1	Contributions from the mismatch components.....	118
6.8.4.2.2	Contributions from the individual components.....	119
6.8.4.2.3	Contribution from the random component.....	123
6.8.4.2.4	Summary table of contributory components.....	124
6.8.4.2.5	Expanded uncertainty for the receiver Sensitivity measurement.....	125
6.9	Examples of measurement uncertainty analysis (Stripline).....	125
6.9.1	Introduction.....	125
6.9.2	Example 1: Verification procedure.....	125
6.9.2.1	Uncertainty contributions: Stage 1: Direct attenuation measurement.....	126
6.9.2.1.1	Contributions from the mismatch components.....	126
6.9.2.1.2	Contributions from individual components.....	129
6.9.2.1.3	Contribution from the random component.....	131
6.9.2.1.4	Summary table of contributory components.....	132
6.9.2.2	Uncertainty contributions: Stage 2: Radiated attenuation measurement.....	132
6.9.2.2.1	Contributions from the mismatch components.....	133
6.9.2.2.2	Contributions from individual components.....	135
6.9.2.2.3	Contribution from the random component.....	138
6.9.2.2.4	Summary table of contributory components.....	139
6.9.2.2.5	Expanded uncertainty for the verification procedure.....	139
6.9.3	Example 2: The measurement of a receiver parameter (Sensitivity).....	139
6.9.3.1	Uncertainty contributions: Stage 1: EUT measurement.....	140
6.9.3.1.1	Contributions from the mismatch components.....	140
6.9.3.1.2	Contributions from the individual components.....	142
6.9.3.1.3	Contribution from the random component.....	145
6.9.3.1.4	Summary table of contributory components.....	146
6.9.3.2	Uncertainty contributions: Stage 2: Field measurement using the results of the verification procedure.....	146
6.9.3.2.1	Expanded uncertainty for the receiver sensitivity measurement.....	147
6.9.3.3	Uncertainty contributions: Stage 2: Field measurement using a monopole.....	147
6.9.3.3.1	Contributions from the mismatch components.....	147
6.9.3.3.2	Contributions from the individual components.....	149
6.9.3.3.3	Contribution from the random component.....	152
6.9.3.3.4	Summary table of contributions.....	153
6.9.3.3.5	Expanded uncertainty for the receiver sensitivity measurement.....	153
6.9.3.4	Uncertainty contributions: Stage 2: Field measurement using 3-axis probe.....	154
6.9.3.4.1	Contributions from the mismatch components.....	154
6.9.3.4.2	Contributions from the individual components.....	155
6.9.3.4.3	Contribution from the random component.....	158
6.9.3.4.4	Summary table of contributory components.....	158
6.9.3.4.5	Expanded uncertainty for the receiver sensitivity measurement.....	159
7	Transmitter measurement examples.....	159
7.1	Conducted.....	159
7.1.1	Frequency error.....	159
7.1.2	Carrier power.....	160
7.1.3	Adjacent channel power.....	164
7.1.3.1	Adjacent channel power method 1 (Using an adjacent channel power meter).....	164
7.1.3.2	Adjacent channel power method 2 (Using a spectrum analyser).....	165
7.1.4	Conducted spurious emissions.....	167
7.1.4.1	Direct reading method.....	167
7.1.4.2	Substitution method.....	170
7.1.5	Intermodulation attenuation.....	172
7.1.6	Attack time.....	174
7.1.6.1	Frequency behaviour (attack).....	174
7.1.6.2	Power behaviour (attack).....	176
7.1.7	Release time.....	177
7.1.7.1	Frequency behaviour (release).....	177

7.1.7.2	Power behaviour (release).....	177
7.1.8	Transient behaviour of the transmitter .....	177
7.1.8.1	Transient frequency behaviour .....	177
7.1.8.2	Power level slope.....	178
7.1.9	Frequency deviation.....	179
7.1.9.1	Maximum permissible frequency deviation .....	179
7.1.9.2	Response of the transmitter to modulation frequencies above 3 kHz .....	180
7.2	Radiated tests .....	181
7.2.1	Frequency error (30 MHz to 1 000 MHz).....	181
7.2.1.1	Anechoic Chamber .....	181
7.2.1.1.1	Contributions from the measurement .....	181
7.2.1.1.2	Expanded uncertainty .....	181
7.2.1.2	Anechoic Chamber with a ground plane.....	181
7.2.1.2.1	Contributions from the measurement .....	181
7.2.1.2.2	Expanded uncertainty .....	182
7.2.1.3	Open Area Test Site.....	182
7.2.1.3.1	Contributions from the measurement .....	182
7.2.1.3.2	Expanded uncertainty .....	182
7.2.1.4	Stripline.....	182
7.2.1.5	Test fixture.....	182
7.2.1.5.1	Contributions from the measurement .....	183
7.2.1.5.2	Expanded uncertainty .....	183
7.2.2	Effective radiated power (30 MHz to 1 000 MHz) .....	183
7.2.2.1	Anechoic Chamber .....	183
7.2.2.1.1	Uncertainty contributions: Stage one: EUT measurement .....	183
7.2.2.1.2	Uncertainty contributions: Stage two: Substitution .....	184
7.2.2.1.3	Expanded uncertainty .....	185
7.2.2.2	Anechoic Chamber with a ground plane.....	186
7.2.2.2.1	Uncertainty contributions: Stage one: EUT measurement.....	186
7.2.2.2.2	Uncertainty contributions: Stage two: Substitution measurement.....	187
7.2.2.2.3	Expanded uncertainty .....	188
7.2.2.3	Open Area Test Site.....	188
7.2.2.3.1	Uncertainty contributions: Stage one: EUT measurement.....	188
7.2.2.3.2	Uncertainty contributions: Stage two: Substitution measurement.....	189
7.2.2.3.3	Expanded uncertainty .....	190
7.2.2.4	Stripline.....	190
7.2.2.5	Test fixture.....	190
7.2.2.5.1	Contributions from the measurement .....	191
7.2.2.5.2	Expanded uncertainty .....	191
7.2.3	Radiated spurious emissions.....	191
7.2.3.1	Anechoic Chamber .....	191
7.2.3.1.1	Uncertainty contributions: Stage one: EUT measurement.....	191
7.2.3.1.2	Uncertainty contributions: Stage two: Substitution .....	192
7.2.3.1.3	Expanded uncertainty .....	193
7.2.3.2	Anechoic Chamber with a ground plane.....	194
7.2.3.2.1	Uncertainty contributions: Stage one: EUT measurement.....	194
7.2.3.2.2	Uncertainty contributions: Stage two: Substitution measurement.....	195
7.2.3.2.3	Expanded uncertainty .....	196
7.2.3.3	Open Area Test Site.....	196
7.2.3.3.1	Uncertainty contributions: Stage one: EUT measurement.....	196
7.2.3.3.2	Uncertainty contributions: Stage two: Substitution measurement.....	197
7.2.3.3.3	Expanded uncertainty .....	198
7.2.3.4	Stripline.....	198
7.2.3.5	Test fixture.....	198
7.2.4	Adjacent channel power .....	198
7.2.4.1	Anechoic Chamber .....	198
7.2.4.2	Anechoic Chamber with a ground plane.....	199
7.2.4.3	Open Area Test Site.....	199
7.2.4.4	Stripline.....	199
7.2.4.5	Test fixture.....	199
7.2.4.5.1	Contributions from the measurement .....	199
7.2.4.5.2	Expanded uncertainty .....	199

History ..... 200

---

# Intellectual Property Rights

IPRs essential or potentially essential to the present document may have been declared to ETSI. The information pertaining to these essential IPRs, if any, is publicly available for **ETSI members and non-members**, and can be found in ETSI SR 000 314: *"Intellectual Property Rights (IPRs); Essential, or potentially Essential, IPRs notified to ETSI in respect of ETSI standards"*, which is available from the ETSI Secretariat. Latest updates are available on the ETSI Web server (<http://www.etsi.org/ipr>).

Pursuant to the ETSI IPR Policy, no investigation, including IPR searches, has been carried out by ETSI. No guarantee can be given as to the existence of other IPRs not referenced in ETSI SR 000 314 (or the updates on the ETSI Web server) which are, or may be, or may become, essential to the present document.

---

## Foreword

This Technical Report (TR) has been produced by ETSI Technical Committee Electromagnetic compatibility and Radio spectrum Matters (ERM).

In the second edition, the area of data communication measurement uncertainties has been addressed and added to the work on analogue measurement uncertainties found in the first edition of the present document; in addition the diagrams had been standardized and minor editorial corrections had been carried out.

---

## Introduction

The present document has been written to clarify the many problems associated with the calculation, interpretation and application of measurement uncertainty and is expected to be used, in particular, by accredited test laboratories performing measurements.

The present document is intended to provide, for the relevant standards, methods of calculating the measurement uncertainty relating to the assessment of the performance of radio equipment. The present document is not intended to replace any test methods in the relevant standards although clauses 5, 6 and 7 (in part 1) contain brief descriptions of each measurement (such descriptions are just intended to support the explanations relating to the evaluation of the uncertainties).

More precisely, the basic purpose of the present document is to:

- provide the method of calculating the total measurement uncertainty (see, in particular annex D (in part 2) and clauses 1 to 5 of part 1);
- provide the maximum acceptable "window" of measurement uncertainty (see table B.1 in annex B (in part 2)), when calculated using the methods described in the present document;
- provide the equipment under test dependency functions (see table F.1 in annex F (in part 2)) which shall be used in the calculations unless these functions are evaluated by the individual laboratories;
- provide a recommended method of applying the uncertainties in the interpretation of the results (see annex C (in part 2)).

Although the present document has been written in a way to cover a larger spread of equipment than what is actually stated in the scope (in order to help as much as possible) the particular aspects needed regarding some technologies such as TDMA may have been left out, even though the general approach to measurement uncertainties and the theoretical background is, in principle, independent of the technology.

Hence, the present document is applicable to measurement methodology in a broad sense but care should be taken when using it to draft new standards or when applying it to a particular technology such as TDMA or CDMA.

In an attempt to help the user and in order to clarify the particular aspects of each method, a number of examples have been given (including spread sheets relating to clause 7 of part 1 and clause 4 of part 2).



However, these examples may have been drafted by different authors. In a number of cases, simplifications may have been introduced (e.g.  $\text{Log}(1+x) = x$ : simplifications and, hopefully, not real errors), in order to reach practical conclusions, while avoiding supplementary complications.

As a result, examples covering similar areas may not be fully consistent. The reader is therefore expected to understand fully the theoretical basis underlying the present document (annex D (in part 2) provides the basis for the theoretical approach) and to exercise his own judgement while using the present document.

As a result, under no circumstances, could ETSI be held for responsible for any consequence of the usage of the present document.

---

# 1 Scope

The present document provides a method to be applied to all the applicable standards and (E)TRs, and supports TR 100 027 [11].

It covers the following aspects relating to measurements:

- a) methods for the calculation of the total uncertainty for each of the measured parameters;
- b) recommended maximum acceptable uncertainties for each of the measured parameters;
- c) a method of applying the uncertainties in the interpretation of the results.

The present document provides the methods of evaluating and calculating the measurement uncertainties and the required corrections on measurement conditions and results (these corrections are necessary in order to remove the errors caused by certain deviations of the test system due to its known characteristics (such as the RF signal path attenuation and mismatch loss, etc.)).

---

# 2 References

For the purposes of this Technical Report (TR) the following references apply:

- [1] The new IEEE standard dictionary of electrical and electronic terms. Fifth edition, IEEE Piscataway, NJ USA 1993.
- [2] Antenna theory, C. Balanis, J. E. Wiley 1982.
- [3] Antenna engineering handbook, R. C. Johnson, H. Jasik.
- [4] "Control of errors on Open Area Test Sites", A. A. Smith Jnr. EMC technology October 1982 pg 50-58.
- [5] IEC 60050-161: "International Electrotechnical Vocabulary. Chapter 161: Electromagnetic compatibility".
- [6] "The gain resistance product of the half-wave dipole", W. Scott Bennet Proceedings of IEEE vol. 72 No. 2 Dec 1984 pp 1824-1826.
- [7] Wave transmission, F. R. Conner, Arnold 1978.
- [8] Antennas, John D. Kraus, Second edition, McGraw Hill.
- [9] Antennas and radio wave propagation, R. E. Collin, McGraw Hill.
- [10] Guide to the Expression of Uncertainty in Measurement (International Organization for Standardization, Geneva, Switzerland, 1995).
- [11] ETSI TR 100 027: "Electromagnetic compatibility and Radio spectrum Matters (ERM); Methods of measurement for private mobile radio equipment".
- [12] ETSI ETR 273: "Electromagnetic compatibility and Radio spectrum Matters (ERM); Improvement of radiated methods of measurement (using test sites) and evaluation of the corresponding measurement uncertainties".
- [13] ITU-T Recommendation O.41: "Psophometer for use on telephone-type circuits".
- [14] ITU-T Recommendation O.153: "Basic parameters for the measurement of error performance at bit rates below the primary rate".
- [15] ETSI ETR 028: "Radio Equipment and Systems (RES); Uncertainties in the measurement of mobile radio equipment characteristics".

- [16] CENELEC EN 55020: "Electromagnetic immunity of broadcast receivers and associated equipment".
- [17] ETSI TR 100 028-2: "Electromagnetic compatibility and Radio spectrum Matters (ERM); Uncertainties in the measurement of mobile radio equipment characteristics; Part 2".

## 3 Definitions, symbols and abbreviations

### 3.1 Definitions

For the purposes of the present document, the following terms and definitions apply:

**accuracy:** This term is defined, in relation to the measured value, in clause 4.1.1; it has also been used in the rest of the document in relation to instruments.

**AF load:** resistor of sufficient power rating to accept the maximum audio output power from the EUT

The value of the resistor should be that stated by the manufacturer and should be the impedance of the audio transducer at 1 000 Hz.

NOTE 1: In some cases it may be necessary to place an isolating transformer between the output terminals of the receiver under test and the load.

**AF termination:** any connection other than the *audio frequency load* which may be required for the purpose of testing the receiver (i.e. in a case where it is required that the bit stream be measured, the connection may be made, via a suitable interface, to the discriminator of the receiver under test)

NOTE 2: The termination device should be agreed between the manufacturer and the testing authority and details should be included in the test report. If special equipment is required then it should be provided by the manufacturer.

**antenna:** that part of a transmitting or receiving system that is designed to radiate or to receive electromagnetic waves

**antenna factor:** quantity relating the strength of the field in which the antenna is immersed to the output voltage across the load connected to the antenna

When properly applied to the meter reading of the measuring instrument, yields the electric field strength in V/m or the magnetic field strength in A/m.

**antenna gain:** ratio of the maximum radiation intensity from an (assumed lossless) antenna to the radiation intensity that would be obtained if the same power were radiated isotropically by a similarly lossless antenna

**Bit error ratio:** ratio of the number of bits in error to the total number of bits

**combining network:** multipole network allowing the addition of two or more test signals produced by different sources (e.g. for connection to a receiver input)

NOTE 3: Sources of test signals should be connected in such a way that the impedance presented to the receiver should be 50  $\Omega$ . The effects of any intermodulation products and noise produced in the signal generators should be negligible.

**correction factor:** numerical factor by which the uncorrected result of a measurement is multiplied to compensate for an assumed systematic error

**confidence level:** probability of the accumulated error of a measurement being within the stated range of uncertainty of measurement

**directivity:** ratio of the maximum radiation intensity in a given direction from the antenna to the radiation intensity averaged over all directions (i.e. directivity = antenna gain + losses)

**duplex filter:** *duplex filter* is a device fitted internally or externally to a transmitter/receiver combination to allow simultaneous transmission and reception with a single antenna connection

**error of measurement (absolute):** result of a measurement minus the true value of the measurand

**error (relative):** ratio of an error to the true value

**estimated standard deviation:** from a sample of n results of a measurement the estimated standard deviation is given by the formula:

$$\sigma = \sqrt{\frac{\sum_{i=1}^n (x_i - \bar{x})^2}{n-1}}$$

$x_i$  being the  $i^{\text{th}}$  result of measurement ( $i = 1, 2, 3, \dots, n$ ) and  $\bar{x}$  the arithmetic mean of the n results considered.

A practical form of this formula is:

$$\sigma = \sqrt{\frac{Y - \frac{X^2}{n}}{n-1}}$$

Where X is the sum of the measured values and Y is the sum of the squares of the measured values.

The term **standard deviation** has also been used in the present document to characterize a particular probability density. Under such conditions, the term **standard deviation** may relate to situations where there is only one result for a measurement.

**expansion factor:** multiplicative factor used to change the confidence level associated with a particular value of a measurement uncertainty

The mathematical definition of the expansion factor can be found in annex D, clause D.5.6.2.2.

**extreme test conditions:** *extreme test conditions* are defined in terms of temperature and supply voltage. Tests should be made with the extremes of temperature and voltage applied simultaneously. The upper and lower temperature limits are specified in the relevant ETS. The test report should state the actual temperatures measured

**error (of a measuring instrument):** indication of a measuring instrument minus the (conventional) true value

**free field:** field (wave or potential) which has a constant ratio between the electric and magnetic field intensities

**free space:** region free of obstructions and characterized by the constitutive parameters of a vacuum

**impedance:** measure of the complex resistive and reactive attributes of a component in an alternating current circuit

**impedance (wave):** complex factor relating the transverse component of the electric field to the transverse component of the magnetic field at every point in any specified plane, for a given mode

**influence quantity:** quantity which is not the subject of the measurement but which influences the value of the quantity to be measured or the indications of the measuring instrument

**intermittent operation:** manufacturer should state the maximum time that the equipment is intended to transmit and the necessary standby period before repeating a transmit period

**isotropic radiator:** hypothetical, lossless antenna having equal radiation intensity in all directions

**limited frequency range:** specified smaller frequency range within the full frequency range over which the measurement is made

NOTE 4: The details of the calculation of the *limited frequency range* should be given in the relevant deliverable.

**maximum permissible frequency deviation:** maximum value of frequency deviation stated for the relevant channel separation in the relevant deliverable

**measuring system:** complete set of measuring instruments and other equipment assembled to carry out a specified measurement task

**measurement repeatability:** closeness of the agreement between the results of successive measurements of the same measurand carried out subject to all the following conditions:

- the same method of measurement;
- the same observer;
- the same measuring instrument;
- the same location;
- the same conditions of use;
- repetition over a short period of time

**measurement reproducibility:** closeness of agreement between the results of measurements of the same measurand, where the individual measurements are carried out changing conditions such as:

- method of measurement;
- observer;
- measuring instrument;
- location;
- conditions of use;
- time

**measurand:** quantity subjected to measurement

**noise gradient of EUT:** function characterizing the relationship between the RF input signal level and the performance of the EUT, e.g. the SINAD of the AF output signal

**nominal frequency:** defined as one of the channel frequencies on which the equipment is designed to operate

**nominal mains voltage:** declared voltage or any of the declared voltages for which the equipment was designed

**normal test conditions:** defined in terms of temperature, humidity and supply voltage stated in the relevant deliverable

**normal deviation:** frequency deviation for analogue signals which is equal to 12 % of the channel separation

**psophometric weighting network:** should be as described in ITU-T Recommendation O.41 [13]

**polarization:** for an electromagnetic wave, this is the figure traced as a function of time by the extremity of the electric vector at a fixed point in space

**quantity (measurable):** attribute of a phenomenon or a body which may be distinguished qualitatively and determined quantitatively

**rated audio output power:** maximum output power under normal test conditions, and at standard test modulations, as declared by the manufacturer

**rated radio frequency output power:** maximum carrier power under normal test conditions, as declared by the manufacturer

**shielded enclosure:** structure that protects its interior from the effects of an exterior electric or magnetic field, or conversely, protects the surrounding environment from the effect of an interior electric or magnetic field

**SINAD sensitivity:** minimum standard modulated carrier-signal input required to produce a specified SINAD ratio at the receiver output

**stochastic (random) variable:** variable whose value is not exactly known, but is characterized by a distribution or probability function, or a mean value and a standard deviation (e.g. a measurand and the related measurement uncertainty)

**test load:** 50  $\Omega$  substantially non-reactive, non-radiating power attenuator which is capable of safely dissipating the power from the transmitter

**test modulation:** test modulating signal is a baseband signal which modulates a carrier and is dependent upon the type of EUT and also the measurement to be performed

**trigger device:** circuit or mechanism to trigger the oscilloscope timebase at the required instant

It may control the transmit function or inversely receive an appropriate command from the transmitter.

**uncertainty:** parameter, associated with the result of a measurement, that characterizes the dispersion of the values that could reasonably be attributed to that measurement

**uncertainty (random):** component of the uncertainty of measurement which, in the course of a number of measurements of the same measurand, varies in an unpredictable way (and has not being considered otherwise)

**uncertainty (systematic):** component of the uncertainty of measurement which, in the course of a number of measurements of the same measurand remains constant or varies in a predictable way

**uncertainty (type A):** uncertainties evaluated using the statistical analysis of a series of observations

**uncertainty (type B):** uncertainties evaluated using other means than the statistical analysis of a series of observations

**uncertainty (limits of uncertainty of a measuring instrument):** extreme values of uncertainty permitted by specifications, regulations etc. for a given measuring instrument

NOTE 5: This term is also known as "tolerance".

**uncertainty (standard):** for each individual uncertainty component, an expression characterizing the uncertainty for that component

It is the standard deviation of the corresponding distribution.

**uncertainty (combined standard):** uncertainty characterizing the complete measurement or part thereof

It is calculated by combining appropriately the standard uncertainties for each of the individual contributions identified in the measurement considered or in the part of it which has been considered.

NOTE 6: In the case of additive components (linearly combined components where all the corresponding coefficients **are equal to one**) and when all these contributions are independent of each other (stochastic), this combination is calculated by using the Root of the Sum of the Squares (the RSS method). A more complete methodology for the calculation of the combined standard uncertainty is given in annex D; see in particular, clause D.3.12 of part 2.

**uncertainty (expanded):** expanded uncertainty is the uncertainty value corresponding to a specific confidence level different from that inherent to the calculations made in order to find the combined standard uncertainty

The combined standard uncertainty is multiplied by a constant to obtain the expanded uncertainty limits (see part 1, clause 5.3 and also clause D.5 (and more specifically clause D.5.6.2) of annex D in part 2).

**upper specified AF limit:** *upper specified audio frequency limit* is the maximum audio frequency of the audio pass-band and is dependent on the channel separation

**wanted signal level:** for conducted measurements the *wanted signal level* is defined as a level of +6 dB/ $\mu$ V emf referred to the receiver input under *normal test conditions*. Under *extreme test conditions* the value is +12 dB/ $\mu$ V emf

NOTE 7: For analogue measurements the wanted signal level has been chosen to be equal to the limit value of the measured usable sensitivity. For bit stream and message measurements the wanted signal has been chosen to be +3 dB above the limit value of measured usable sensitivity.

## 3.2 Symbols

For the purposes of the present document, the following symbols apply:

$\beta$	$2\pi/\lambda$ (radians/m)
$\gamma$	incidence angle with ground plane ( $^{\circ}$ )
$\lambda$	wavelength (m)
$\phi_H$	phase angle of reflection coefficient ( $^{\circ}$ )
$\eta$	$120\pi \Omega$ - the intrinsic impedance of free space ( $\Omega$ )
$\mu$	permeability (H/m)
$AF_R$	antenna factor of the receive antenna (dB/m)
$AF_T$	antenna factor of the transmit antenna (dB/m)
$AF_{TOT}$	mutual coupling correction factor (dB)
$C_{cross}$	cross correlation coefficient
$D(\theta, \phi)$	directivity of the source
$d$	distance between dipoles (m)
$\delta$	skin depth (m)
$d_1$	an antenna or EUT aperture size (m)
$d_2$	an antenna or EUT aperture size (m)
$d_{dir}$	path length of the direct signal (m)
$d_{refl}$	path length of the reflected signal (m)
$E$	electric field intensity (V/m)
$E_{DH}^{max}$	calculated maximum electric field strength in the receiving antenna height scan from a half wavelength dipole with 1 pW of radiated power (for horizontal polarization) ( $\mu\text{V/m}$ )
$E_{DV}^{max}$	calculated maximum electric field strength in the receiving antenna height scan from a half wavelength dipole with 1 pW of radiated power (for vertical polarization) ( $\mu\text{V/m}$ )
$e_{ff}$	antenna efficiency factor
$\phi$	angle ( $^{\circ}$ )
$\Delta f$	bandwidth (Hz)
$f$	frequency (Hz)
$G(\theta, \phi)$	gain of the source (which is the source directivity multiplied by the antenna efficiency factor)
$H$	magnetic field intensity (A/m)
$I_0$	the (assumed constant) current (A)
$I_m$	the maximum current amplitude
$k$	$2\pi/\lambda$
$k$	a factor from Student's distribution
$k$	Boltzmann's constant ( $1,38 \times 10^{-23} \text{ J}^{\circ}\text{K}$ )
$K$	relative dielectric constant
$l$	the length of the infinitesimal dipole (m)
$L$	the overall length of the dipole (m)
$l$	the point on the dipole being considered (m)
$\lambda$	wavelength (m)
$Pe_{(n)}$	probability of error n
$Pp_{(n)}$	probability of position n
$P_r$	antenna noise power (W)
$P_{rec}$	power received (W)
$P_t$	power transmitted (W)
$\theta$	angle ( $^{\circ}$ )
$\rho$	reflection coefficient
$r$	the distance to the field point (m)
$\rho_g$	reflection coefficient of the generator part of a connection
$\rho_l$	reflection coefficient of the load part of the connection
$R_s$	equivalent surface resistance ( $\Omega$ )
$\sigma$	conductivity (S/m)
$\sigma$	standard deviation
$SNR_{b*}$	Signal to noise ratio at a specific BER

SNR <sub>b</sub>	Signal to noise ratio per bit
T <sub>A</sub>	antenna temperature (°K)
U	the expanded uncertainty corresponding to a confidence level of x %: $U = k \times u_c$
u <sub>c</sub>	the combined standard uncertainty
u <sub>i</sub>	general type A standard uncertainty
u <sub>i01</sub>	random uncertainty
u <sub>j</sub>	general type B uncertainty
u <sub>j01</sub>	reflectivity of absorbing material: EUT to the test antenna
u <sub>j02</sub>	reflectivity of absorbing material: substitution or measuring antenna to the test antenna
u <sub>j03</sub>	reflectivity of absorbing material: transmitting antenna to the receiving antenna
u <sub>j04</sub>	mutual coupling: EUT to its images in the absorbing material
u <sub>j05</sub>	mutual coupling: de-tuning effect of the absorbing material on the EUT
u <sub>j06</sub>	mutual coupling: substitution, measuring or test antenna to its image in the absorbing material
u <sub>j07</sub>	mutual coupling: transmitting or receiving antenna to its image in the absorbing material
u <sub>j08</sub>	mutual coupling: amplitude effect of the test antenna on the EUT
u <sub>j09</sub>	mutual coupling: de-tuning effect of the test antenna on the EUT
u <sub>j10</sub>	mutual coupling: transmitting antenna to the receiving antenna
u <sub>j11</sub>	mutual coupling: substitution or measuring antenna to the test antenna
u <sub>j12</sub>	mutual coupling: interpolation of mutual coupling and mismatch loss correction factors
u <sub>j13</sub>	mutual coupling: EUT to its image in the ground plane
u <sub>j14</sub>	mutual coupling: substitution, measuring or test antenna to its image in the ground plane
u <sub>j15</sub>	mutual coupling: transmitting or receiving antenna to its image in the ground plane
u <sub>j16</sub>	range length
u <sub>j17</sub>	correction: off boresight angle in the elevation plane
u <sub>j18</sub>	correction: measurement distance
u <sub>j19</sub>	cable factor
u <sub>j20</sub>	position of the phase centre: within the EUT volume
u <sub>j21</sub>	positioning of the phase centre: within the EUT over the axis of rotation of the turntable
u <sub>j22</sub>	position of the phase centre: measuring, substitution, receiving, transmitting or test antenna
u <sub>j23</sub>	position of the phase centre: LPDA
u <sub>j24</sub>	stripline: mutual coupling of the EUT to its images in the plates
u <sub>j25</sub>	stripline: mutual coupling of the 3-axis probe to its image in the plates
u <sub>j26</sub>	stripline: characteristic impedance
u <sub>j27</sub>	stripline: non-planar nature of the field distribution
u <sub>j28</sub>	stripline: field strength measurement as determined by the 3-axis probe
u <sub>j29</sub>	stripline: Transform Factor
u <sub>j30</sub>	stripline: interpolation of values for the Transform Factor
u <sub>j31</sub>	stripline: antenna factor of the monopole
u <sub>j32</sub>	stripline: correction factor for the size of the EUT
u <sub>j33</sub>	stripline: influence of site effects
u <sub>j34</sub>	ambient effect
u <sub>j35</sub>	mismatch: direct attenuation measurement
u <sub>j36</sub>	mismatch: transmitting part
u <sub>j37</sub>	mismatch: receiving part
u <sub>j38</sub>	signal generator: absolute output level
u <sub>j39</sub>	signal generator: output level stability
u <sub>j40</sub>	insertion loss: attenuator
u <sub>j41</sub>	insertion loss: cable
u <sub>j42</sub>	insertion loss: adapter
u <sub>j43</sub>	insertion loss: antenna balun



$u_{j44}$	antenna: antenna factor of the transmitting, receiving or measuring antenna
$u_{j45}$	antenna: gain of the test or substitution antenna
$u_{j46}$	antenna: tuning
$u_{j47}$	receiving device: absolute level
$u_{j48}$	receiving device: linearity
$u_{j49}$	receiving device: power measuring receiver
$u_{j50}$	EUT: influence of the ambient temperature on the ERP of the carrier
$u_{j51}$	EUT: influence of the ambient temperature on the spurious emission level
$u_{j52}$	EUT: degradation measurement
$u_{j53}$	EUT: influence of setting the power supply on the ERP of the carrier
$u_{j54}$	EUT: influence of setting the power supply on the spurious emission level
$u_{j55}$	EUT: mutual coupling to the power leads
$u_{j56}$	frequency counter: absolute reading
$u_{j57}$	frequency counter: estimating the average reading
$u_{j58}$	Salty-man/Salty-lite: human simulation
$u_{j59}$	Salty-man/Salty-lite: field enhancement and de-tuning of the EUT
$u_{j60}$	Test Fixture: effect on the EUT
$u_{j61}$	Test Fixture: climatic facility effect on the EUT
$V_{\text{direct}}$	received voltage for cables connected via an adapter (dB $\mu$ V/m)
$V_{\text{site}}$	received voltage for cables connected to the antennas (dB $\mu$ V/m)
$W_0$	radiated power density (W/m <sup>2</sup> )

Other symbols which are used only in annexes D or E of part 2 are defined in the corresponding annexes.

### 3.3 Abbreviations

For the purposes of the present document, the following abbreviations apply:

AF	Audio Frequency
A-M1	test modulation consisting of a 1 000 Hz tone at a level which produces a deviation of 12 % of the channel separation
A-M2	test modulation consisting of a 1 250 Hz tone at a level which produces a deviation of 12 % of the channel separation
A-M3	test modulation consisting of a 400 Hz tone at a level which produces a deviation of 12 % of the channel separation. This signal is used as an unwanted signal for analogue and digital measurements
BER	Bit Error Ratio
BIPM	International Bureau of Weights and Measures (Bureau International des Poids et Mesures)
c	calculated on the basis of given and measured data
d	derived from a measuring equipment specification
DM-0	test modulation consisting of a signal representing an infinite series of '0' bits
DM-1	test modulation consisting of a signal representing an infinite series of '1' bits
DM-2	test modulation consisting of a signal representing a pseudorandom bit sequence of at least 511 bits in accordance with ITU-T Recommendation O.153 [14]
D-M3	test signal should be agreed between the testing authority and the manufacturer in the cases where it is not possible to measure a bit stream or if selective messages are used and are generated or decoded within an equipment

NOTE: The agreed test signal may be formatted and may contain error detection and correction. Details of the test signal should be supplied in the test report.

emf	electromotive force
EUT	Equipment Under Test
FSK	Frequency Shift Keying
GMSK	Gaussian Minimum Shift Keying
GSM	Global System for Mobile telecommunication (Pan European digital telecommunication system)
IF	Intermediate Frequency
m	measured

NaCl	Sodium chloride
NSA	Normalized Site Attenuation
p	power level value
v	voltage level value
r	indicates rectangular distribution
RF	Radio Frequency
rms	root mean square
RSS	Root-Sum-of-the-Squares
u	indicates U-distribution
VSWR	Voltage Standing Wave Ratio

---

## 4 Introduction to measurement uncertainty

This clause gives the general background to the subject of measurement uncertainty and is the basis of ETR 273 [12]. It covers methods of evaluating both individual components and overall system uncertainties and ends with a discussion of the generally accepted present day approach to the calculation of overall measurement uncertainty.

For further details and for the basis of a theoretical approach, please see annex D of TR 100 028-2 [17].

An outline of the extensions and improvements recommended is also included in this clause.

This clause should be viewed as introductory material for clauses 5 and 6, and to some extent, also for annex D of part 2.

### 4.1 Background to measurement uncertainty

#### 4.1.1 Commonly used terms

UNCERTAINTY is that part of the expression of the result of a measurement which states the range of values within which the true value is estimated to lie.

ACCURACY is an estimate of the closeness of the measured value to the true value. An accurate measurement is one in which the uncertainties are small. This term is not to be confused with the terms PRECISION or REPEATABILITY which characterize the ability of a measuring system to give identical indications or responses for repeated applications of the same input quantity.

Measuring exactly a quantity (referred to as the measurand) is an ideal which cannot be attained in practical measurements. In every measurement a difference exists between the TRUE VALUE and the MEASURED VALUE. This difference is termed "THE ABSOLUTE ERROR OF THE MEASUREMENT". This error is defined as follows:

$$\text{Absolute error} = \text{the measured value} - \text{the true value.}$$

Since the true value is never known exactly, it follows that the absolute error cannot be known exactly either. The above formula is the defining statement for the terms of ABSOLUTE ERROR and TRUE VALUE, but, as a result of neither ever being known, it is recommended that these terms are never used.

In practice, many aspects of a measurement can be controlled (e.g. temperature, supply voltage, signal generator output level, etc.) and by analysing a particular measurement set-up, the overall uncertainty can be assessed, thereby providing upper and lower UNCERTAINTY BOUNDS within which the true value is believed to lie.

The overall uncertainty of a measurement is an expression of the fact that the measured value is only one of an infinite number of possible values dispersed (spread) about the true value.

This is further developed in annex D, clause D.5.6 of part 2.

## 4.1.2 Assessment of upper and lower uncertainty bounds

One method of providing upper and lower bounds is by straightforward arithmetic calculation in the worst case condition, using the individual uncertainty contributions. This method can be used to arrive at a value each side of the measured result within which, there is utmost confidence (100 %) that the true value lies (see also annex D, clause D.5.6.1 in part 2).

When estimating the measurement uncertainty in the worst case e.g. by simply adding the uncertainty bounds (in additive situations), (extremely) pessimistic uncertainty bounds are often found. This is because the case when all the individual uncertainty components act to their maximum effect in the same direction at the same time is, in practice, very unlikely to happen (it has to be noted, however, that the usage of expansion factors in order to increase the confidence levels (see also clause 5.3.1 and in annex D, clauses D.5.6.2.2 and D.3.3.5.2 in part 2) may have a balancing effect).

To overcome this (very) pessimistic calculation of the lower and upper bounds, a more realistic approach to the calculation of overall uncertainty needs to be taken (i.e. a probabilistic approach).

The method presented in the present document is based on the approach to expressing uncertainty in measurement as recommended by the Comité International des Poids et Mesures (CIPM) in 1981. This approach is founded on Recommendation INC-1 (1980) of the Working Group on the Statement of Uncertainties. This group was convened in 1980 by the Bureau International des Poids et Mesures (BIPM) as a consequence of a request by the Comité that the Bureau study the question of reaching an international consensus on expressing uncertainty in measurement. Recommendation INC-1 (1980) led to the development of the *Guide to the Expression of Uncertainty in Measurement* [10] (the Guide), which was prepared by the *International Organization for Standardization Technical Advisory Group 4 (ISOTAG 4)*, Working Group 3. The Guide was the most complete reference on the general application of the BIPM approach to expressing measurement uncertainty. Further theoretical analysis has been introduced in the third edition of the present document (see, in particular, annexes D and E in part 2).

Although the Guide represented the current international view of how to express uncertainty it is a rather lengthy document that is not easily interpreted for radiated measurements. The guidance given in the present document is intended to be applicable to radio measurements but since the Guide itself is intended to be generally applicable to measurement results, it should be consulted for additional details, if needed.

The method in both the present document and the Guide apply statistical/probabilistic analysis to estimate the overall uncertainties of a measurement and to provide associated confidence levels. They depend on knowing the magnitude and distribution of the individual uncertainty components. This approach is commonly known as the BIPM method.

Basic to the BIPM method is the representation of each individual uncertainty component that contributes to the overall measurement uncertainty by an estimated standard deviation, termed **standard uncertainty** [10], with suggested symbol  $u$ .

All individual uncertainties are categorized as either Type A or Type B. Type A uncertainties, symbol  $u_i$ , are estimated by statistical methods applied to repeated measurements, whilst Type B uncertainties, symbol  $u_j$ , are estimated by means of available information and experience.

The **combined standard uncertainty** [10], symbol  $u_c$ , of a measurement is calculated by combining the standard uncertainties for each of the individual contributions identified. In the case where the underlying physical effects are additive, this is done by applying the "Root of the Sum of the Squares (the RSS)" method (see also annex D, clause D.3.3 in part 2) under the assumption that all contributions are stochastic i.e. independent of each other.

The table included in annex D, clause D.3.12 of part 2 provides the way in which should be handled contributions to the uncertainty which correspond to physical effects which are not additive. Clause D.5 of the same annex provides an overview of several general methods.

The resulting combined standard uncertainty can then be multiplied by a constant  $k_{xx}$  to give the uncertainty limits (bounds), termed **expanded uncertainty** [10], in order to provide a confidence level of  $xx$  %. This is further discussed in annex D, clause D.5.6.2 of part 2.

One of the main assumptions when calculating uncertainty using the basic BIPM method is that the combined standard uncertainty of a measurement has a Normal or Gaussian distribution (see also annex D, clause D.1.3.4 in part 2) with an associated standard deviation (the present document often uses the term Normal). This may be true when there is an infinite number of contributions in the uncertainty, which is generally not the case in the examples discussed in the present document (an interesting example is provided in annex D, clause D.3.3.5.2.2 of part 2).

Should the combined standard uncertainty correspond to a Normal distribution, then the multiplication by the appropriate constant (expansion factor) will provide the sought confidence level.

The case where the combined standard uncertainty corresponds to non-Gaussian distributions is also considered in annex D, clauses D.5.6.2.3 and D.5.6.2.4, in part 2.

The Guide defines the combined standard uncertainty for this distribution  $u_c$ , as equal to the standard deviation of a corresponding Normal distribution. The mean value is assumed to be zero as the measured result is corrected for all known errors. Based on this assumption, the uncertainty bounds corresponding to any confidence level can be calculated as  $k_{xx} \times u_c$  (see also annex D, clause D.5.6.2 of part 2).

To illustrate the true meaning of a typical final statement of measurement uncertainty using this method, if the combined standard uncertainty is associated with a Normal distribution, confidence levels can be assigned as follows:

- 68,3 % confidence level that the true value is within bounds of  $1 \times u_c$ ;
- 95 % confidence within  $\pm 1,96 \times u_c$ , etc.

Care must be taken in the judgement of which unit is chosen for the calculation of the uncertainty bounds. In some types of measurements the correct unit is logarithmic (dB); in other measurements it is linear (i.e. V or %). The choice depends on the model and architecture of the test system. In any measurement there may be a combination of different types of unit. The present document breaks new ground by giving methods for conversion between units (e.g. dB into V %, power % into dB, etc.) thereby allowing all types of uncertainty to be combined. Details of the conversion schemes are given in clause 5, and theoretical support in annexes D and E of part 2.

### 4.1.3 Combination of rectangular distributions

The following example shows that the overall uncertainty, when all contributions of a measurement have the **same** rectangular distribution, approaches a Normal distribution.

The case of a discrete approach to a rectangularly distributed function, (the outcome of throwing a die), is shown and how, with up to 6 individual events simultaneously, (6 dice thrown at the same time) the events combine together to produce an output increasingly approximating a Normal distribution.

Initially with 1 die the output mean is 3,5 with a rectangularly distributed 'error' of  $\pm 2,5$ . With 2 dice the output is  $7 \pm 5$  and is triangularly distributed see figure 1.

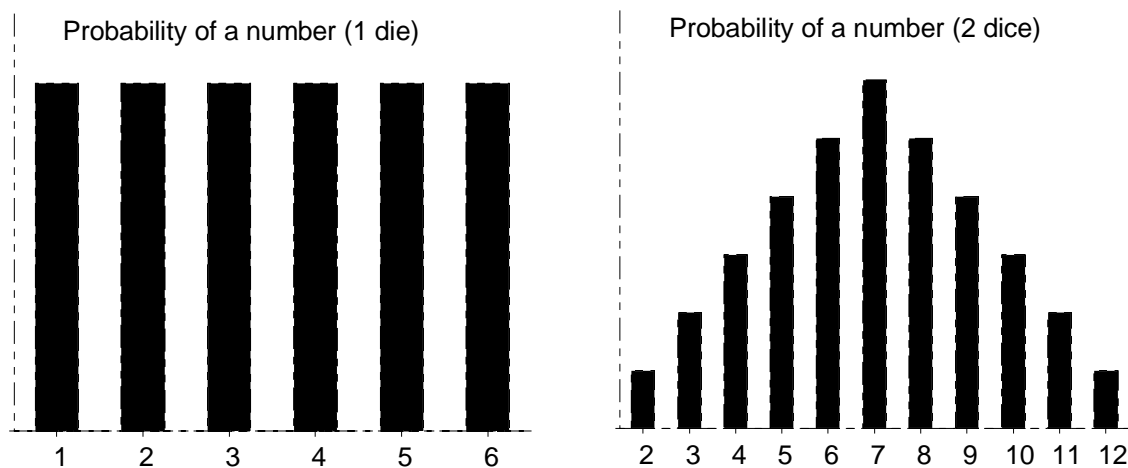

Figure 1: One and two die outcomes

By increasing the number of dice further through 3, 4, 5 and 6 dice it can be seen from figures 2 and 3, that there is a central value (most probable outcome) respectively for 2, 3, 4, 5 and 6 dice of (7), (10,5), (14), (17,5) and (21) and an associated spread of the results that increasingly approximates a Normal distribution. It is possible to calculate the mean and standard deviation for these events.

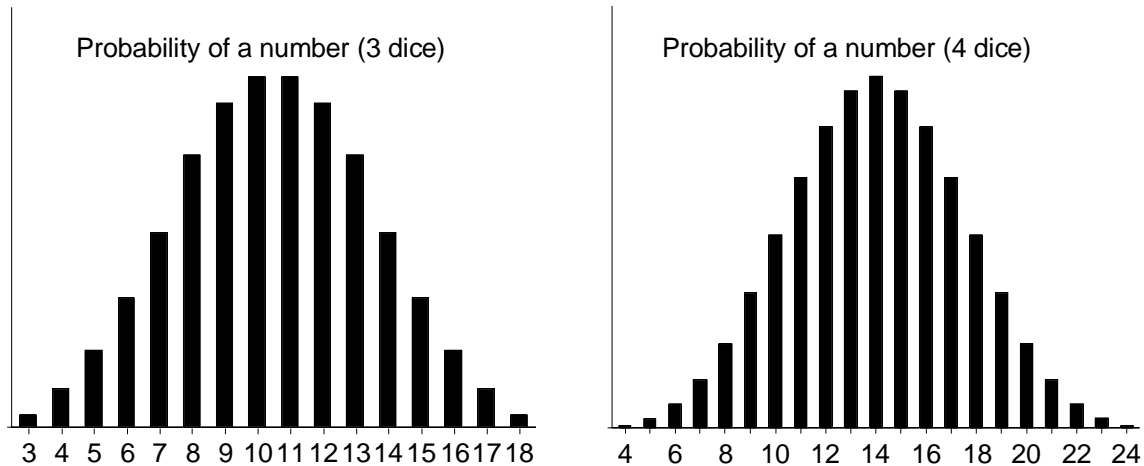

Figure 2: Three and four die outcomes

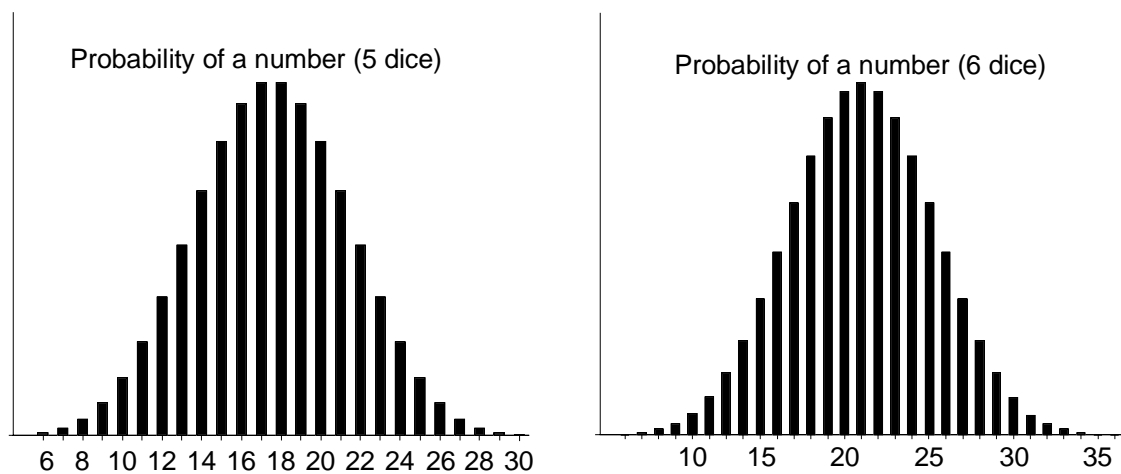

Figure 3: Five and six die outcomes

The practical interpretation of the standard deviation of a Normally distributed quantity is that 68,3 % of all its possible values will lie within  $\pm 1$  standard deviation of the mean value, 95,45 % will lie within  $\pm 2$  standard deviations. Another way to regard these standard deviations is "as confidence levels", e.g. a confidence level of 68,3 % attaches to one standard deviation, 95,45 % to two standard deviations.

Using the mathematical definition of a Gaussian (see annex D in part 2), it is possible to calculate the expanded measurement uncertainty for other confidence levels.

This illustration shows that in the case of individual throws of a die (which corresponds to a set of identical rectangular distributions since any of the values 1 to 6 is equally likely) the overall probability curve approximates closer and closer that of a Normal distribution as more dice are used.

The BIPM method extends this principle by combining the individual standard uncertainties to derive a combined standard uncertainty. The standard uncertainties (corresponding to the distributions of the individual uncertainties) are all that need to be known (or assumed) to apply this approach. From the assumption that the final combined standard uncertainty corresponds to a Normal distribution, it is possible to calculate the expanded uncertainty for a given confidence level.

The confidence level should always be stated in any test report, in the case where the resulting distribution is Gaussian. In such case, it makes it possible for the user of the measured results to calculate expanded uncertainty figures corresponding to other confidence levels.

For similar reasons, in the case where there is no evidence that the distribution corresponding to the combined uncertainty is Normal, the expansion factor,  $k_{xx}$ , should be stated in the test report, instead. Usually, for the reasons stated above,  $k_{xx} = 1,96$  is used (see also annex D, clause D.5.6.2 of part 2).

An expansion factor,  $k_{xx} = 2,00$  could also be acceptable; it would provide a confidence level of 95,45 % should the corresponding distribution be Normal.

#### 4.1.4 Main contributors to uncertainty

The main contributors to the overall uncertainty of a measurement comprise:

- systematic uncertainties: those uncertainties inherent in the test equipment used (instruments, attenuators, cables, amplifiers, etc.), and in the method employed. These uncertainties cannot always be eliminated (calculated out) although they may be constant values, however they can often be reduced;
- uncertainties relating to influence quantities i.e. those uncertainties whose magnitudes are dependant on a particular parameter or function of the EUT. The magnitude of the uncertainty contribution can be calculated, for example, from the slope of "dB RF level" to "dB SINAD" curve for a receiver or from the slope of a power supply voltage effect on the variation of a carrier output power or frequency;
- random uncertainties: those uncertainties due to chance events which, on average, are as likely to occur as not to occur and are generally outside the engineer's control.

NOTE: When making a measurement care must be taken to ensure that the measured value is not affected by unwanted or unknown influences. Extraneous influences (e.g. ambient signals on an Open Area Test Site) should be eliminated or minimized by, for example, the use of screened cables.

#### 4.1.5 Other contributors

Other contributors to the overall uncertainty of a measurement can relate to the standard itself:

- the type of measurement (direct field, substitution or conducted) and the test method have an effect on the uncertainty. These can be the most difficult uncertainty components to evaluate. As an illustration, if the same measurand is determined by the same method in different laboratories (as in a round robin) or alternatively by different methods either in the same laboratory or in different laboratories, the results of the testing will often be widely spread, thereby showing the potential uncertainties of the different measurement types and test methods;
- a direct field measurement involves only a single testing stage in which the required parameter (ERP, sensitivity, etc.) is indirectly determined as the received level on a receiving device, or as the output level of a signal generator, etc., and is subsequently converted to ERP, field strength, etc., by a calculation involving knowledge of antenna gain, measurement distance, etc. This method, whilst being of short time duration, offers no way of allowing for imperfections (reflections, mutual coupling effects, etc.) in the test site and can result in large overall uncertainty values;
- the substitution technique, on the other hand, is a two stage measurement in which the unknown performance of an EUT (measured in one stage) is directly compared with the "known" performance of some standard (usually an antenna) in the other stage. This technique therefore subjects both the EUT and the known standard to (hopefully) the same external influences of reflections, mutual coupling, etc., whose effects on the different devices are regarded as identical. As a consequence, these site effects are deemed to cancel out (this has also been addressed in clause D.5.3.2 of annex D, in part 2). Some residual effects do remain however, (due to different elevation beamwidths, etc.) but these tend to be small compared to the uncertainties in the direct field method. All the test methods in the present document are substitution measurements;
- for their part, test methods can contain imprecise and ambiguous instructions which could be open to different interpretations;

- an inadequate description of the measurand can itself be a source of uncertainty in a measurement. In practice a measurand cannot be completely described without an infinite amount of information. Because this definition is incomplete it therefore introduces into the measurement result a component of uncertainty that may or may not be significant relative to the overall uncertainty required of the measurement. The definition of the measurand may, for example, be incomplete because:
  - it does not specify parameters that may have been assumed, unjustifiably, to have negligible effect (i.e. coupling to the ground plane, reflections from absorbers or that reference conditions remain constant);
  - it leaves many other matters in doubt that might conceivably affect the measurement (i.e. supply voltages, the layout of power, signal and antenna cables);
  - it may imply conditions that can never be fully met and whose imperfect realization is difficult to take into account (i.e. an infinite, perfectly conducting ground plane, a free space environment) etc.

Maximum acceptable uncertainties and confidence levels (or expansion factors) are both defined in most ETSI standards.

## 4.2 Evaluation of individual uncertainty components

As discussed in clause 4.1.4, uncertainty components can be categorized either as "random" or "systematic". Such categorization of components of uncertainty can be ambiguous if they are applied too rigorously. For example, a "random" component of uncertainty in one measurement may become a "systematic" component of uncertainty in another measurement e.g. where the result of a first measurement is used as a component of a second measurement. Categorizing the methods of evaluating the uncertainty components rather than the components themselves avoids this ambiguity.

Instead of "systematic" and "random" uncertainty the types of uncertainty contribution are grouped into two categories:

- Type A: those which are evaluated by statistical methods;
- Type B: those which are evaluated by other means.

The classification into Type A and Type B is not meant to indicate that there is any difference in the nature of the components, it is simply a division based on their means of evaluation. Both types will possess probability distributions (although they may be governed by different rules), and the uncertainty components resulting from either type may be quantified by standard deviations.

### 4.2.1 Evaluation of Type A uncertainties

When we carry out a measurement more than once and find the results are different, the following questions arise:

- What to do with the results?
- How much variation is acceptable?
- When do we suspect the measuring system is faulty?
- Are the conditions repeatable?

Variations in these repeated measurements are assumed to be due to influence and random quantities that affect the measurement result and cannot be held completely constant. Therefore none of the results is necessarily correct. In practice, repeated measurements of the same measurand can help us evaluate these Type A uncertainties. By treating the results statistically, we can derive the mean (the best approximation to the "true value") and standard deviation values. The standard deviation can then be incorporated as a standard uncertainty into the calculation of combined standard uncertainty, when the corresponding component is part of some measurement system.

Uncertainties determined from repeated measurements are often thought of as statistically rigorous and therefore absolutely correct. This implies, sometimes wrongly, that their evaluation does not require the application of some judgement. For example:

- When carrying out a series of measurements do the results represent completely independent repetitions or are they in some way biased?

- Are we trying to assess the randomness of the measurement system, or the randomness in an individual EUT, or the randomness in all of the EUT produced?
- Are the means and standard deviations constant, or is there perhaps a drift in the value of an unmeasured influence quantity during the period of repeated measurements?
- Are the results stable with ambient conditions?

If all of the measurements are on a single EUT, whereas the requirement is for sampling, then the observations have not been independently repeated. An estimate of the standard uncertainty arising from possible differences among production EUT should, in this case, be incorporated into the combined standard uncertainty calculation along with the calculated standard uncertainty of the repeated observations made on the single equipment (e.g. for characterizing a set of pieces of equipment).

If an instrument is calibrated against an internal reference as part of the measurement procedure, (such as the "cal out" reference on a spectrum analyser), then the calibration should be carried out as part of every repetition, even if it is known that the drift is small during the period in which observations are made.

If the EUT is rotated during a radiated test on a test site and the azimuth angle read, it should be rotated and read for each repetition of the measurement, for there may be a variation both in received level and in azimuth reading, even if everything else is constant.

If a number of measurements have been carried out on the same EUT/types of EUT, but in two groups spaced apart in time, the arithmetic means of the results of the first and second groups of measurements and their experimentally derived means and standard deviations may be calculated and compared. This will enable a judgement to be made as to whether any time varying effects are statistically significant.

## 4.2.2 Evaluation of Type B uncertainties

Some examples of Type B uncertainties are:

- mismatch;
- losses in cables and components;
- non linearities in instruments;
- antenna factors.

Type B uncertainties do not reveal themselves as fluctuations as do Type A uncertainties; they can only be assessed by careful analysis of test and calibration data.

For incorporation into an overall analysis, the magnitudes and distributions of Type B uncertainties can be estimated based on:

- manufacturers' information/specification about instruments and components in the test set-up;
- data in calibration certificates (if the history of the instrument is known);
- experience with the behaviour of the instruments.

## 4.2.3 Uncertainties relating to influence quantities

Uncertainties relating to influence quantities are, as a result of the way they are treated in the present document, regarded as a subgroup of Type B uncertainties. Some examples of influence quantities are:

- power supply;
- ambient temperature;
- time/duty cycle.

Their effect is evaluated using some relationship between the measured parameter e.g. output power and the influence quantity e.g. supply voltage.



Dependency functions (e.g. the relationship between output power and the fluctuating quantity), as those given in the present document, should be used to calculate the properties corresponding to the effect considered.

A theoretical approach to influence quantities and dependency functions can be found in annex D, part 2 (see clause D.4).

### 4.3 Methods of evaluation of overall measurement uncertainty

The uncertainty of the measurement is a combination of many components.

Some of these components may be evaluated from the statistical distributions of the results of a series of measurements (Type A uncertainty) whilst other components are evaluated from assumed probability distributions based on experience or other information (Type B uncertainty).

The exact error of a result of a measurement is, in general, unknown and unknowable. All that can be done is to estimate the values of all quantities likely to contribute to the combined standard uncertainty, including those uncertainties associated with corrections for recognized systematic offset effects. With knowledge of the magnitudes of their individual standard uncertainties, it is then possible to calculate the combined standard uncertainty of the measurement.

At present the assessment of the number of uncertainty components for any particular test is very variable. Whilst some general agreement has been reached on the manner in which individual uncertainties should be combined (the BIPM method, see also the discussion of such methods in part 2, annex D, in particular, in clause D.5), no such agreement has been arrived at concerning the identity of those individual components. Consequently, it is left to the particular test house/engineer/etc. to decide the contributory uncertainties, and to assess which are independent and which are not. This can lead to considerable test house to test house variation for the same test and is heavily dependent, in general, on the experience of the test engineer.

A model of the measurement can assist in the evaluation of combined standard uncertainty since it will enable all known individual components of uncertainty to be rigorously included in the analysis, and correctly combined (see annex D in part 2, and, in particular, the table in clause D.3.12).

### 4.4 Summary

The measured result can be affected by many variables, some of which are shown in figure 4.

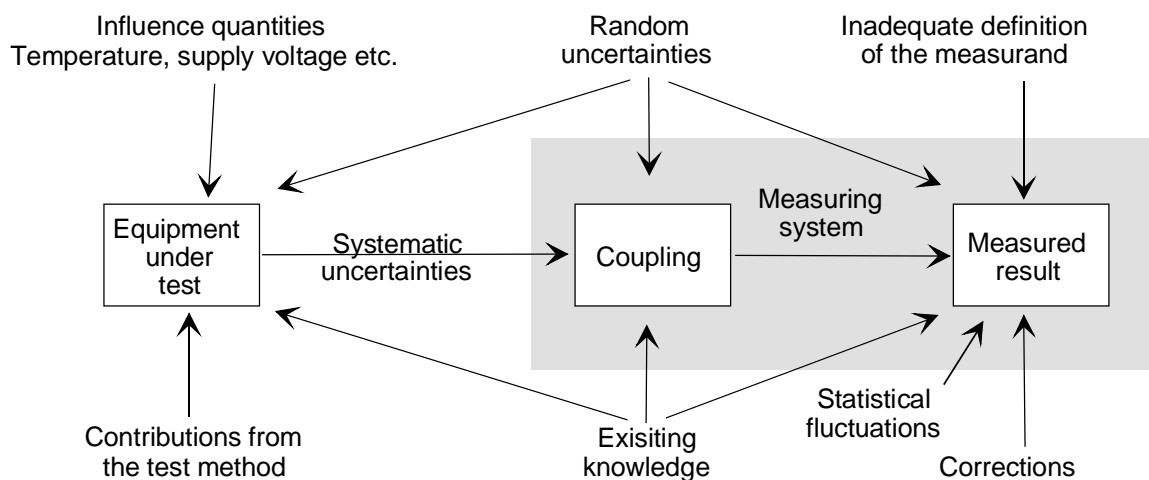

Figure 4: The measurement model

## 4.5 Overview of the approach of the present document

The present document proposes an approach to the calculation of the combined standard uncertainty of a measurement which includes solutions to the present day imperfections.

For example, in clause 5, a technique is put forward for converting linear standard deviations into logarithmic ones (and vice versa) so that all uncertainty contributions for a particular test can be combined in the same units (dB, Voltage % or power %), and as stated above, comprehensive lists of the individual uncertainty sources for the tests are attached. Instructions within the test methods have been made more detailed and thereby less ambiguous.

A global approach for the analysis of the uncertainties corresponding to a complete measurement set up (i.e. "a complete system") is also proposed in annex D, clause D.5. This approach addresses, in particular, the concept of "sub-systems" and how to combine the uncertainties relating to each "sub-system". Such an approach could help in cases where different units are to be used (e.g. dBs in one sub-system, linear terms in another).

A set of files (spread sheets) has been included in the present document, in order to support some of the examples given and to help the user in the implementation of his own methodology.

---

## 5 Analysis of measurement uncertainty

This clause develops the approach to measurement uncertainty beyond the introduction given in clause 4. It details the improvements to the analysis which the present document is proposing and presents solutions for all the identified problems associated with the BIPM method for calculating measurement uncertainty in radiated measurements. Clause 6 presents numerous worked examples which illustrate the application of the proposed new techniques.

In the beginning of this clause, a review is given of the BIPM method, along with an outline of where it is inadequate for radiated measurements. The means of evaluation of Type A and Type B uncertainties are also given.

This is followed by a discussion of the units in which the uncertainties are derived and the technique for converting standard deviations from logarithmic to linear quantities (% voltage or % power and vice versa) is presented. The conversion technique allows all the individual uncertainty components in a particular test to be combined in the same units and overcomes a major current day problem of asymmetric uncertainty limits (e.g.  $x + 2$ ,  $-3$  dB, as found in edition 2 of ETR 028 [15]).

The clause concludes with clauses on deriving the expanded uncertainties in the case of Normal distributions, how influence quantities are dealt with, calculating the standard deviation of random effects and an overall clause summary.

Theoretical and mathematical support for this clause can be found in annex D (in part 2).

### 5.1 The BIPM method

Basic to the BIPM method is the representation of each individual uncertainty component that contributes to the overall measurement uncertainty by an estimated standard deviation, termed **standard uncertainty** [10], with suggested symbol  $u$ .

All individual uncertainties are categorized as either Type A or Type B.

Type A uncertainties, symbol  $u_i$ , are estimated by statistical methods applied to repeated measurements, whilst Type B uncertainties, symbol  $u_j$ , are estimated by means of available information and experience.

The **combined standard uncertainty** [10], symbol  $u_c$ , of a measurement is calculated by combining the standard uncertainties for each of the individual contributions identified. In the case where the underlying physical effects are additive, this is done by applying the Root of the Sum of the Squares (the RSS) method under the assumption that all contributions are stochastic i.e. independent of each other. The table included in annex D, clause D.3.12 of part 2 provides the way in which should be handled contributions to the uncertainty which correspond to physical effects which are not additive. Clause D.5 of the same annex provides an overview of several more general methods.

The resulting combined standard uncertainty can then be multiplied by a constant  $k_{xx}$  to give the uncertainty limits (bounds), termed **expanded uncertainty** [10]. When the combined standard uncertainty corresponds to a Normal distribution (see clause 4.1.3) the expanded uncertainty corresponds to a confidence level of  $xx$  %.

This is the broad outline of the analysis technique employed in the present document, but there are numerous practical problems when applying the basic BIPM rules to measurements, such as:

- how uncertainty contributions in different units (dB, % voltage, % power) can be combined;
- whether individual uncertainties are functions of the true value (e.g. Bit error ratios);
- how to deal with asymmetrically distributed individual uncertainties;
- how to define confidence limits for those standard uncertainties which are not Normal by nature (see also clause D.5.6.2 in part 2).

These problem areas are discussed below and have resulted in modifications and extensions to the BIPM method. For most cases, examples are given in clause 6.

In order to help understanding some of these questions and to bring some more theoretical support, annexes D and E (found in part 2) have been added to the third edition of the present document. Clause D.3 supports various combinations (e.g. additive, multiplicative, etc.), conversions (e.g. to and from dBs) and functions (see clauses D.3.9 and D.3.11). A complete approach, encompassing the "BIPM method" is included in annex D, clause D.5 (part 2).

### 5.1.1 Type A uncertainties and their evaluation

Type A uncertainties are evaluated by statistical methods, estimating their standard deviations (corresponding to "standard uncertainties"). These normally play a minor part in the combined standard uncertainty.

Annex D (in part 2) shows that, in most cases, it is only the standard uncertainty that needs to be known in order to find the combined uncertainty. In the BIPM approach, the shape of the individual distributions is relatively unimportant. However, annex D shows how to combine the various individual distributions, when needed, and that the result of a combination does not necessarily correspond to a Normal distribution. In such a case, the actual shape of the resulting distribution may be fully relevant (see, in particular, clauses D.5.6.2.3 and D.5.6.2.4).

### 5.1.2 Type B uncertainties and their evaluation

Type B uncertainties are estimated by various methods.

Figure 5 illustrates a selection of uncertainty distributions which can often be identified in RF measurements.

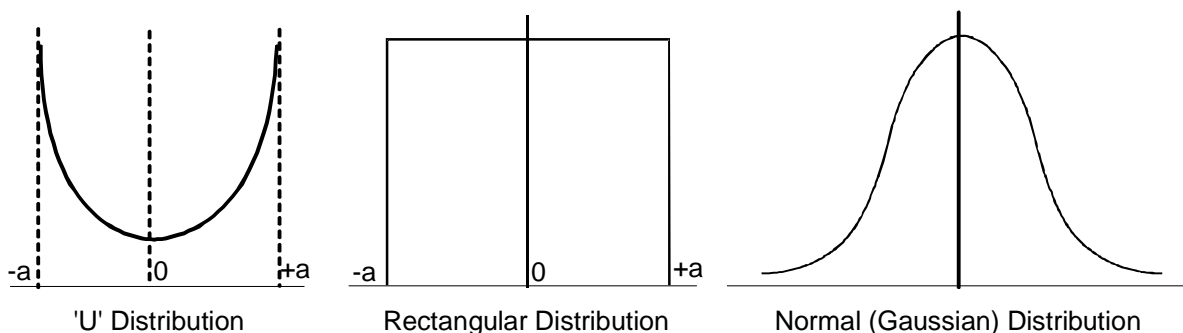

**Figure 5: Types of uncertainty distribution**

Mismatch uncertainties have the "U" distribution, see annex G. The value of the uncertainty contribution is more likely to be near the limits than to be small or zero. If the limits are  $\pm a$ , the standard uncertainty is:

$$\frac{a}{\sqrt{2}} \text{ (see annex D).}$$

Systematic uncertainties (e.g. those associated with the loss in a cable) are, unless the actual distribution is known, assumed to have a rectangular distribution. The result of this assumption is that the uncertainty can take any value between the limits with equal probability. If the limits are  $\pm a$ , the standard uncertainty is:

$$\frac{a}{\sqrt{3}} \text{ (see annex D).}$$

If the distribution used to model the uncertainty is a Normal distribution, it is characterized by its standard deviation (standard uncertainty) (see annex D).

In the present document the standard uncertainties are symbolized by  $u_{j,xx}$  or  $u_{j,description}$ .

In all cases where the distribution of the uncertainty is unknown, the rectangular distribution should be taken as the default model.

It will be noted that all the distributions illustrated in figure 5 are symmetrical about zero (clause D.1, in annex D, addresses also distributions showing an offset and/or which are not symmetrical). An unexpected complication in combining standard uncertainty contributions may result from the use of different units, since a symmetrical standard uncertainty in % voltage is asymmetrical in dB (and vice versa). Similarly for % power. This "major" complication (for any particular test, the contributions may be in a variety of units) is the subject of clause 5.2. See also clause D.3 and in particular clause D.3.10.7 in annex D, part 2.

## 5.2 Combining individual standard uncertainties in different units

The BIPM method for calculating the combined standard uncertainty of any test involves combining the individual standard uncertainties by the RSS method. If there are  $n$  individual standard uncertainty contributions to be combined, the combined standard uncertainty is:

$$u_c = \sqrt{u_{j1}^2 + u_{j2}^2 + u_{j3}^2 + \dots + u_{j(n-1)}^2 + u_{jn}^2 + \dots + u_{i1}^2 + u_{i2}^2 + u_{i3}^2 + \dots + u_{i(n-1)}^2 + u_{in}^2} \quad (5.1)$$

However, this is only correct, if all the individual contributions, represented by their standard uncertainties:

- (1) combine by addition; and
- (2) are expressed in the same units.

It does not matter whether the contributions are expressed in percent or logarithmic terms or any other terms as long as these two conditions are fulfilled... noting that the result of the corresponding combination will be expressed in the same way (see also conversions in clause D.3 and the discussion on the concept of sub-systems in clause D.5 of part 2).

To use formula 5.1 for standard uncertainties of individual contributions which combine by **addition**, linear terms only i.e. voltage, percentage, etc., should be used. This is essential for the RSS combination to be valid. This is the case in many measuring instruments.

To use formula 5.1 for standard uncertainties of individual contributions which combine by **multiplication**, logarithmic terms only i.e. dB should be used as they can then be combined by addition. This is essential for the RSS combination to be valid where uncertainty multiplication occurs. This is the case where gains and/or losses (i.e. attenuators, amplifiers, antennas, etc.) are involved as well as under mismatch conditions where modules (i.e. attenuators, cables, RF measuring instruments, etc.) are interconnected in RF measurements.

If all parameters and their associated standard uncertainties in a measurement are in the same unit and combine by addition, the RSS method can be applied directly. The table in clause D.3.12 (annex D, part 2) shows how to handle other cases. Clause D.5 (in part 2) discusses general methods usable in most cases.

**For small (< 30 % or 2,5 dB) standard uncertainties however, both additive and multiplicative contributions can be incorporated into the same calculation (with negligible error) provided they are converted to the same units prior to calculating the combined standard uncertainty. The conversion factors are given in table 1. This is supported by the theoretical analysis provided in annex D, clause D.3 and annex E (part 2).**

Annex E gives the justification for this statement by firstly mathematically converting the distribution of an individual uncertainty from logarithmic to linear (and vice versa) and secondly comparing the standard deviation of the two distributions before and after the conversion. One of the outcomes of annex E is that the conversion between linear and logarithmic standard uncertainties can, under some conditions, be approximated by the first order mathematical functions given in table 1.

As can be seen from annex E there are, however, some problems involved in converting distributions.

- It is not a linear procedure; the conversion factor is not only dependent on the magnitude of the standard uncertainty, but it is also dependent on the shape of the distribution.
- The mean value of the converted uncertainty distribution is not necessarily zero, even if that was the case before the conversion. However if the **standard uncertainties** to be converted are less than 2,5 dB, 30 % (voltage), or 50 % (power) the errors arising may be considered as negligible.

Table 1 shows the multiplicative factors to be used when converting **standard uncertainties with a first order approximation**. As an example, if the **standard uncertainty** is 1,5 dB then this, converted to voltage %, gives a corresponding **standard uncertainty** of  $1,5 \times 11,5 \% = 17,3 \%$ .

**Table 1: Standard uncertainty conversion factors**

Converting from standard uncertainties in ...:	Conversion factor multiply by:	To standard uncertainties in ...:
dB	11,5	voltage %
dB	23,0	power %
power %	0,0435	dB
power %	0,5	voltage %
voltage %	2,0	power %
voltage %	0,0870	dB

It should be noted after any conversions that may be necessary before using equation 5.1, that the combined standard uncertainty,  $u_c$ , that results from the application of equation 5.1, does not, by itself give the expanded uncertainty limits for a measurement.

When  $u_c$  corresponds to a Normal distribution, these can be calculated (see clause 5.3) from  $u_c$  (assumed in this case to be in units of dB) as the 95 % confidence limits in dB of  $\pm 1,96 \times u_c$  (which is very asymmetric in linear terms).

Similarly, in voltage as  $\pm 1,96 \times u_c \times 11,5 \%$  (which is very asymmetric in dB terms). The major factor determining whether the combined standard uncertainty,  $u_c$ , will have the symmetrical dB interval or the symmetrical % interval (or somewhere in-between) is whether the individual uncertainties combine by multiplication or by addition. In radiated measurements as well as most conducted measurements where the RF level is of importance, the overwhelming majority of the uncertainties combine by multiplication. It is, therefore, safe to assume that, in general, the resulting uncertainty limits are symmetrical in logarithmic terms (dB). This assumption has been confirmed by computer simulations on a large number of measurement models. This is also clear from the relations found in annex D.

As shown in annex F, the shapes of the individual distributions only matter if they are very large (compared to the rest).

## 5.3 Calculation of the expanded uncertainty values and Student's t-distribution

This clause discusses two different problems, both relating to the handling of uncertainties, which have to be very clearly identified and handled separately. Unfortunately, in the previous editions of the present document, this clause had not been subdivided into two clauses.

The two clauses address:

- the situation where the **statistical properties of a number of samples** are to be evaluated; in this case, the **Student's t-distribution** is a powerful tool allowing to evaluate the performance of those properties; it can be helpful in supporting the evaluation of properties of "type A uncertainties";
- the situation where **only one measurement** is performed, in conditions where the various sources of uncertainty have been evaluated; as a result, the combined standard uncertainty of that measurement may be evaluated (see annex D, clause D.5, in part 2), and the **knowledge of the shape of the distribution** corresponding to that combined uncertainty **allows for changes in the confidence level**.

### 5.3.1 Student's t-distribution

The Student's t-distribution gives coverage factors (i.e. multipliers) for measurements, whereby the confidence level of a series of measurement can be calculated from a limited number of samples, assuming those samples have been taken from a Normal distribution. The fewer the number of samples, the bigger the coverage factor for a given confidence level.

For example:

- if a type A standard deviation is calculated on only 3 samples and the required confidence level is 95 % the appropriate Student's t-factor is 3,18;
- if the standard deviation had been based on 20 samples, the factor would have been 2,09;
- for an infinite number of samples the multiplier would have been 1,96.

When using such an approach, any measurement should be repeated a large number of times.

In radio measurements, however, by using the approach recommended in the present document, only one measurement is usually performed. As a result, the Student's t-distribution is of no help.

The Student's t-distribution can, however, be very useful for the statistical evaluation of the properties of individual uncertainty components (i.e. type A uncertainties which may happen to be part of some test set up).

### 5.3.2 Expanded uncertainties

When the combined standard uncertainty,  $u_c$ , has been calculated from equation 5.1 (or by any other method) and it can be expected that the corresponding distribution is Normal, then, the uncertainty limits relate to a confidence level of 68,3 % (due to the properties of the Gaussian curve).

By multiplying  $u_c$  by "a coverage factor" (or "an expansion factor") other confidence levels may be obtained when the distribution corresponding to the combined standard uncertainty,  $u_c$ , is Normal. Why?

When:

- all the individual sources of uncertainty are identified for all the tests;
- the distributions of the uncertainties of the individual sources are all known (or assumed);
- the maximum, worst-case values of all of the individual uncertainties are known.

Then, under these conditions, annex D of part 2 applies and the combined standard uncertainty can be calculated (see clause D.5).

Assuming that the combined standard uncertainty corresponds to a Normal distribution then the magic factor of 1,96 applies: this is due to the shape of the Gaussian curve used to describe the distribution corresponding to the combined uncertainty (see the interpretation in clause D.5.6.2 of annex D, part 2).

As already indicated above (see clause 4.1.3), for a Gaussian shaped curve:

- a surface of 68 % (2 x 34 %) corresponds to one standard deviation (i.e. a combined standard deviation);
- a surface of 95 % (2 x 47,5 %) corresponds to two standard deviations (more precisely 1,96 standard deviations).

And the surface refereed above can be interpreted as the probability of the true value being within the stated uncertainty (which, in turn, corresponds to the confidence level).

It has to be made clear that, when the combination of the various components of the uncertainty correspond to a distribution which is not Normal, then other factors apply in order to convert from one confidence level to another. These factors depend on the shape (and mathematical properties) of the corresponding distribution.

It has to be made clear also that, as indicated in particular in annex D, when the number of components used to calculate the uncertainty can be considered as an infinity, and under some other conditions, then the distribution can be considered as Normal. Under such conditions, the factor 1,96 appears to be valid. This is why it has been used all over the examples given in the present document.

The usage of a value of 2 for this expansion factor has also been suggested (this would provide a confidence level of 95,45 % in the case of Normal distributions).

The tools given in annex D could allow for the calculation of the actual distribution corresponding to the combination of various components for the uncertainty. Under such conditions, the appropriate expansion factors could also be calculated, in the case where the distribution found would not have happened to be Normal.

## 5.4 Combining standard uncertainties of different parameters, where their influence on each other is dependant on the EUT (influence quantities)

In many measurements, variations in the influence quantities, intermediate test results or test signals can affect the uncertainty of the measurand in ways that may be functions of the characteristics of the EUT and other instrumentation.

It is not always possible to fully characterize test conditions, signals and measurands. Uncertainties are related to each of them. These uncertainties may be well known, but their influence on the combined standard uncertainty depends on the EUT. Uncertainties related to general test conditions are:

- ambient temperature;
- the effect of cooling and heating;
- power supply voltage;
- power supply impedance;
- impedance of test equipment connectors (VSWR).

Uncertainties related to applied test signals and measured values are:

- level;
- frequency;
- modulation;
- distortion;
- noise.

The effect of such uncertainties on the test results can vary from one EUT to another. Examples of the characteristics that can affect the calculation of the uncertainties are:

- receiver noise dependency of RF input signal levels;
- impedance of input and output connectors (VSWR);
- receiver noise distribution;
- performance dependency of changes of test conditions and test signals;
- modulator limiting function e.g. maximum deviation limiting;
- system random noise.

If the appropriate value for each characteristic has not been determined for a particular case, then the values listed in part 2, annex F, table F.1 should be used. These values are based on measurements made with several pieces of equipment and are stated as mean values associated with a standard uncertainty reflecting the spread from one EUT to another.

When the EUT dependent uncertainties add to the combined standard uncertainty, the RSS method of combining the standard uncertainties is used, but in many calculations the EUT dependency is a function that converts uncertainty from one part of the measurement configuration to another. In most cases the function can be assumed to be linear; therefore the conversion is carried out by multiplication. A theoretical analysis is provided in clause D.4 of annex D, in part 2.

The standard uncertainty to be converted is  $u_{j1}$ . The mean value of the influence quantity is  $A$  and its standard uncertainty is  $u_{ja}$ . The resulting standard uncertainty  $u_{jconverted}$  of the conversion is:

$$u_{jconverted} = \sqrt{u_{j1}^2 (A^2 + u_{ja}^2)} \quad (5.2)$$

The standard uncertainty of this contribution is then looked upon as any other individual component and is combined accordingly (see annex D). A fully worked example of an influence quantity is given in clause 6.4.6. The conditions under which the expression 5.2 is valid can also be found in clause D.4 of annex D, in part 2.

If the function is not linear another solution must be found:

- the theoretical relation between the influence quantity and its effect has to be determined;
- the expressions providing the conversion can then be found based on the table contained in clause D.3.12 of annex D (part 2).

When the theoretical relation between the influence quantity and its effect is not known, the usage of a simple mathematical model can be tried. In this case, an attempt can be made in order to determine the numerical values of the parameters of the model by some statistical method (see also clause D.5.4 in part 2).

In all cases, it is recommended to determine first the mathematical relation between the parameters, and only after try and find the appropriate numerical values. As a consequence, tables similar to table F.1 in annex F (part 2) should also include the mathematical relation between the parameters for each entry (for further details, see clause D.4.2.1.2 in part 2).

## 5.5 Estimate of standard uncertainty of randomness

The major difficulty behind this clause is to evaluate what exactly it is supposed to cover: the BIPM method and the corresponding analysis is supposed to cover all components of the uncertainty, so it is fundamental to understand what is left over for the "uncertainty of randomness", and avoid taking into account the same effects in a complex set up twice, under different names...

The standard uncertainty of randomness can be evaluated by repeating a measurement (e.g. of a particular component of the measurement uncertainty).

The first step is to calculate the arithmetic mean or average of the results obtained.

The spread in the measured results reflects the merit of the measurement process and depends on the apparatus used, the method, the sample and sometimes the person making the measurement. A more useful statistic, however, is the standard uncertainty  $\sigma_i$  of the sample. This is the root mean square of the sum of the differences of the measured value minus the arithmetic mean of the sample.

If there are  $n$  results for  $x_m$  where  $m = 1, 2, \dots, n$  and the sample mean is  $\bar{x}$ , then the standard deviation  $\sigma_i$  is:

$$\sigma_i = \sqrt{\frac{1}{n} \sum_{m=1}^n (x_m - \bar{x})^2} \quad (5.3)$$

This should not be confused with the standard deviation of the  $A$  uncertainty being investigated. It only covers  $n$  samples.

If further measurements are made, then for each sample of results considered, different values for the arithmetic mean and standard deviation will be obtained. For large values of  $n$  these mean values approach a central limit value of a distribution of all possible values. This distribution can usually be assumed, for practical purposes, to be a Normal distribution.



From the results of a relatively small number of measurements an estimate can be made of the standard deviation of the whole population of possible values, of which the measured values are a sample.

Estimate of the standard deviation  $\sigma'_i$ :

$$\sigma'_i = \sqrt{\left(\frac{1}{n-1}\right) \sum_{m=1}^n (x_m - \bar{x})^2} \quad (5.4)$$

A practical form of this formula is:

$$\sigma'_i = \sqrt{\frac{Y - \frac{X^2}{n}}{n-1}} \quad (5.5)$$

where  $X$  is the sum of the measured values and  $Y$  is the sum of the squares of the measured values.

It will be noted that the only difference between  $\sigma'_i$  and  $\sigma_i$  is in the factor  $1/(n-1)$  in place of  $1/n$ , so that the difference becomes smaller as the number of measurements is increased. A similar way of calculating the standard deviation of a discrete distribution can be derived from this formula.

In this case  $X$  is the sum of the individual values from the distribution times their probability, and  $Y$  is the sum of the square of the individual values times their probability.

If the distribution has  $m$  values  $x_i$ , each having the probability  $p(x_i)$ :

$$X = \sum_{i=1}^m x_i p(x_i) \quad (5.6)$$

and

$$Y = \sum_{i=1}^m x_i^2 p(x_i) \quad (5.7)$$

The standard uncertainty is then:

$$\sigma_i = \sqrt{Y - \frac{X^2}{n}} \quad (5.8)$$

When a measured results is obtained as the arithmetic mean of a series of  $n$  (independent) measurements the standard uncertainty is reduced by a factor  $1/\sqrt{n}$  thus:

$$\sigma_i = \frac{\sigma'_1}{\sqrt{n}} \quad (5.9)$$

This is an efficient method of reducing measurement uncertainty when making noisy or fluctuating measurements, and it applies both for random uncertainties in the measurement configuration and the EUT. Having established the standard deviation, this is directly equated to the standard uncertainty:

$$u_i = \sigma_i$$

**As the uncertainty due to random uncertainty is highly dependent on the measurement configuration and the test method used it is not possible to estimate a general value.**

Each laboratory must by means of repetitive measurements estimate their own standard uncertainties characterizing the randomness involved in each measurement. Once having done this, the estimations may be used in future measurements and calculations.

NOTE: See also the note found in clause 6.4.7 concerning the usage of this component.

## 5.6 Summary of the recommended approach

The basic BIPM method, with specific modifications, remains the adopted approach used for the calculation of combined standard and expanded uncertainty in the examples given in this report for radiated measurements. That is to say that once all the individual standard uncertainties in a particular measurement have been identified and given values, they are combined by the RSS method **provided they combine by addition and are in the same units (otherwise, methods such as those detailed in annex D, e.g. in clause D.5, have to be used)**.

In order to ensure that this proviso is satisfied as often as possible, the present document supplies the factors necessary to convert standard uncertainties in linear units to standard uncertainties in logarithmic units (and vice versa). The present document also shows that small additive standard uncertainties (% V, % power) can be combined with multiplicative standard uncertainties (dB) in the RSS manner with, hopefully, negligible error.

Having derived the combined standard uncertainty, an expanded uncertainty for 95 % confidence levels can then be derived, when the corresponding distribution is Normal, by multiplying the result by the expansion factor of 1,96. The multiplication by this factor (or simply by a factor equal to 2) is to be done in all cases, in order to obtain the expanded uncertainty. However, if the corresponding distribution is not Normal, then the resulting confidence level is not necessarily 95 % (see clause D.5.6.2 in annex D, part 2). In all cases, however, the actual confidence level can be calculated, once the distribution corresponding to the combination of all uncertainty components has been calculated. Clause D.3, in part 2, provides the equations allowing for the calculation of this combined distribution.

The practical implementation of this modified BIPM approach, adopted throughout the present document, is for each test method (including the verification procedures) to have appended to it a complete list of the individual uncertainty sources that contribute to each stage of the test. Magnitudes of the standard uncertainties can then be assigned to these individual contributions by consulting annex A (converting from linear units to dB, if necessary). All uncertainties are in dB units since the great majority of the individual contributions in radiated measurements are multiplicative i.e. they add in dB terms.

In those cases in which annex A instructs that the values of the uncertainty contributions be taken from a manufacturer's data sheet, that data should be taken **over as broad a frequency band as possible**. This type of approach **avoids the necessity of calculating the combined standard uncertainty every time the same test is performed for different EUT**.

# 6 Examples of uncertainty calculations specific to radio equipment

## 6.1 Mismatch

In the following the Greek letter  $\Gamma$  means the complex reflection coefficient.  $\rho_x$  is the magnitude of the reflection coefficient:  $\rho_x = |\Gamma_x|$ .

Where two parts or elements in a measurement configuration are connected, if the matching is not ideal, there will be an uncertainty in the level of the RF signal passing through the connection. The magnitude of the uncertainty depends on the VSWR at the junction of the two connectors.

The uncertainty limits of the mismatch at the junction are calculated by means of the following formula:

$$\text{Mismatch limits} = |\Gamma_{\text{generator}}| \times |\Gamma_{\text{load}}| \times |S_{21}| \times |S_{12}| \times 100 \% \text{ Voltage} \quad (6.1)$$

where:

$|\Gamma_{\text{generator}}|$  is the modulus of the complex reflection coefficient of the signal generator;

$|\Gamma_{\text{load}}|$  is the modulus of the complex reflection coefficient of the load (receiving device);

$|S_{21}|$  is the forward gain in the network between the two reflection coefficients of interest;

$|S_{12}|$  is the backward gain in the network between the two reflection coefficients of interest.

NOTE:  $S_{21}$  and  $S_{12}$  are set to 1 if the two parts are connected directly. In linear networks  $S_{21}$  and  $S_{12}$  are identical.

The distribution of the mismatch uncertainty is U-shaped, If the uncertainty limits are  $\pm a$ , the standard uncertainty is:

$$u_{j \text{ mismatch:individual}} = \frac{|\Gamma_{generator}| \times |\Gamma_{load}| \times |S_{21}| \times |S_{12}| \times 100\%}{\sqrt{2}} \text{ Voltage \%} \quad (6.2)$$

This can be converted into equivalent dB by dividing by 11,5 (see clause 5.2):

$$u_{j \text{ mismatch:individual}} = \frac{|\Gamma_{generator}| \times |\Gamma_{load}| \times |S_{21}| \times |S_{12}| \times 100\%}{\sqrt{2} \times 11,5} \text{ dB} \quad (6.3)$$

If there are several connections in a test set-up, they will all interact and contribute to the combined mismatch uncertainty. The method of calculating the combined mismatch uncertainty is fully explained in annex G.

In conducted measurements, when calculating the mismatch uncertainty at the antenna connector of the EUT, the reflection coefficient of the EUT is required. In this case, the laboratory should either measure it in advance or use the reflection coefficients given in ETR 028 [15], part 2, annex F, table F.1.

## 6.2 Attenuation measurement

In many measurements the absolute level of the RF signal is part of the measured result. The RF signal path attenuation must be known in order to apply a systematic correction to the result. The RF signal path can be characterized using the manufacturers' information about the components involved, but this method can result in unacceptably large uncertainties.

Another method is to measure the attenuation directly by using, for example, a signal generator and a receiving device. To measure the attenuation, connect the signal generator to the receiving device and read the reference level (A), see figure 6, and then insert the unknown attenuation, repeat the measurement and read the new level (B), see figure 7.

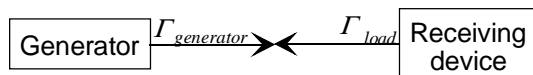

Figure 6: Measurement of level (A)

In figure 6,  $\Gamma_{generator}$  is the complex reflection coefficient of the signal generator and  $\Gamma_{load}$  is the complex reflection coefficient of the load (receiving device).

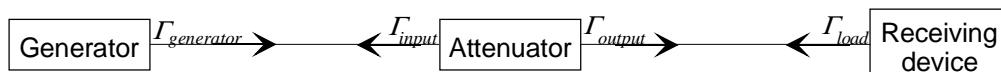

Figure 7: Measurement of level (B)

In figure 7,  $\Gamma_{generator}$  is the complex reflection coefficient of the signal generator,  $\Gamma_{load}$  is the complex reflection coefficient of the load (receiving device),  $\Gamma_{input}$  is the complex reflection coefficient of the attenuator input,  $\Gamma_{output}$  is the complex reflection coefficient of the attenuator output.

The attenuation is calculated as A/B if the readings are linear values or A-B if the readings are in dB.

Using this method, four uncertainty sources need to be considered. Two sources concern the receiving device, namely its absolute level (if the input attenuation range has been changed) and its linearity. The other two sources are the stability of the signal generator output level (which contributes to both stages of the measurement) and mismatch caused by reflections at both the terminals of the network under test and the instruments used. The absolute level, linearity and stability uncertainties can be obtained from the manufacturers data sheets, but the mismatch uncertainty must be estimated by calculation.

For this example, we assume that an attenuator of nominally 20 dB is measured at a frequency of 500 MHz by means of a signal generator and a receiving device. The magnitude of the reflection coefficient of the generator  $|\Gamma_{generator}|$  is 0,2, the magnitude of the reflection coefficient of the receiving device  $|\Gamma_{load}|$  is 0,3 and the magnitude of the reflection coefficients of the attenuator  $|\Gamma_{input}|$  and  $|\Gamma_{output}|$  are 0,05.

Since the mismatch uncertainty of the attenuation measurement is different in figure 7 to that in figure 6, it therefore has to be calculated (for figure 6 and figure 7) and both values included in the combined mismatch uncertainty as shown below.

#### Mismatch uncertainty:

**Reference measurement:** The signal generator is adjusted to 0 dBm and the reference level A is measured on the receiving device. Using equation 6.1 with  $S_{21} = S_{12} = 1$ , and taking the standard uncertainty,

$u_{j \text{ mismatch: reference measurement}}$ :

$$u_{j \text{ mismatch: reference measurement}} = \frac{0,2 \times 0,3 \times 100}{\sqrt{2}} \% = 4,24 \% \approx \frac{4,24}{11,5} = 0,37 \text{ dB}$$

**Attenuator measurement:** The attenuator is inserted and a level (B) = -20,2 dB is measured after an input attenuation range change on the receiving device.

NOTE: The measured attenuation is 20,2 dB, for which  $S_{21} = S_{12} = 0,098$ .

The following three components comprise the uncertainty in this part of the measurement:

- the standard uncertainty of the mismatch between the signal generator and the attenuator:

$$u_{j \text{ mismatch: generator to attenuator}} = \frac{0,2 \times 0,05 \times 100}{\sqrt{2}} \% = 0,71 \%$$

- the standard uncertainty of the mismatch between the attenuator and the receiving device:

$$u_{j \text{ mismatch: attenuator to receiving device}} = \frac{0,3 \times 0,05 \times 100}{\sqrt{2}} \% = 1,06 \%$$

- the standard uncertainty of the mismatch between the signal generator and the receiving device:

$$u_{j \text{ mismatch: generator to receiving device}} = \frac{0,3 \times 0,2 \times 0,098^2 \times 100}{\sqrt{2}} \% = 0,041 \%$$

The combined standard uncertainty of the mismatch of the attenuation measurement  $u_{c \text{ mismatch: att. measurement}}$  is calculated by RSS (clause 5.2) of the individual contributions.

$$u_{c \text{ mismatch: att. measurement}} = \sqrt{0,71^2 + 1,06^2 + 0,041^2} = 1,28 \% \approx \frac{1,28}{11,5} = 0,11 \text{ dB}$$

A comparison of  $u_{j \text{ mismatch: reference measurement}}$  (0,37 dB) and  $u_{c \text{ mismatch: att. measurement}}$  (0,11 dB) shows clearly the impact of inserting an attenuator between two mismatches.

#### Other components of uncertainty:

**Reference measurement:** The stability of the signal generator provides the only other uncertainty in this part. The receiving device contributes no uncertainty here since only a reference level is being set for comparison in the attenuation measurement stage.

The output level stability of the signal generator is taken from the manufacturer's data sheet as 0,10 dB which is assumed (since no information is given) to be rectangularly distributed (see clause 5.1). Therefore the standard uncertainty,  $u_{j \text{ signal generator stability}}$ , is:

$$u_{j \text{ signal generator stability}} = \frac{0,10}{\sqrt{3}} = 0,06 \text{ dB}$$

Therefore, the combined standard uncertainty,  $u_{c \text{ reference measurement}}$ , for the reference measurement is:

$$u_{c \text{ reference measurement}} = \sqrt{u_{j \text{ mismatch:reference measurement}}^2 + u_{j \text{ signal generator stability}}^2} = \sqrt{0,37^2 + 0,06^2} = 0,37 \text{ dB}$$

**Attenuation measurement:** Here the output stability of the signal generator as well as absolute level uncertainty of the receiving device (the input attenuation range has changed) contribute to the uncertainty. However as a range change has occurred there is no linearity contribution as this is included in the absolute level uncertainty of the receiver.

The signal generator stability,  $u_{j \text{ signal generator stability}}$ , has the same value as for the reference measurement, whilst the uncertainty for the receiving device is given in the manufacturer's data sheet as 1,0 dB absolute level accuracy. A rectangular distribution is assumed for the absolute level accuracy so the standard uncertainty,  $u_{j \text{ signal generator level}}$ , of its uncertainty contribution is:

$$u_{j \text{ signal generator level}} = \frac{1,00}{\sqrt{3}} = 0,58 \text{ dB}$$

The uncertainty contribution of the linearity of the receiving device  $u_{j \text{ linearity}}$  is zero.

Therefore the combined standard uncertainty,  $u_{c \text{ att. measurement}}$ , for the attenuation measurement is:

$$\begin{aligned} u_{c \text{ att.measurement}} &= \sqrt{u_{c \text{ mismatch:att.measurement}}^2 + u_{j \text{ signal generator stability}}^2 + u_{j \text{ signal generator level}}^2 + u_{j \text{ linearity}}^2} \\ &= \sqrt{0,08^2 + 0,06^2 + 0,58^2 + 0,00^2} = 0,59 \text{ dB} \end{aligned}$$

So, for the complete measurement, the combined standard uncertainty,  $u_{c \text{ measurement}}$ , is given by:

$$u_{c \text{ measurement}} = \sqrt{u_{c \text{ reference measurement}}^2 + u_{c \text{ att.measurement}}^2} = \sqrt{0,37^2 + 0,59^2} = 0,70 \text{ dB}$$

The expanded uncertainty is  $\pm 1,96 \times 0,70 = \pm 1,37$  dB at a 95 % confidence level.

This is an exaggerated example. Smaller uncertainty is possible if a better receiving device is used.

## 6.3 Calculation involving a dependency function

The specific dependency function is the relationship between the RF signal level at the EUT antenna connector (dB) to the uncertainty of the measurement of SINAD at the EUT's audio output i.e. how does SINAD measurement uncertainty relate to RF level uncertainty at the EUT antenna connector.

The following example is based on a typical ETR 028 [15] type (conducted) RF measurement for clarity. The sensitivity of a receiving EUT is measured. The outline of the measurement is as follows. The RF level at the input of the receiver is continuously reduced until a SINAD measurement of 20 dB is obtained, see figure 8.

The result of the measurement is the RF signal level causing 20 dB SINAD at the audio output of the receiver.

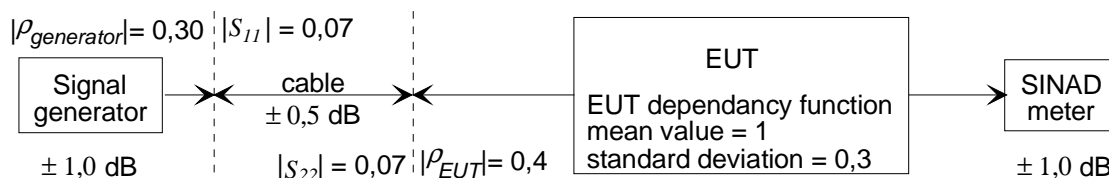

**Figure 8: Typical measurement configuration**

The combined standard uncertainty is calculated as follows.

For the mismatch uncertainty (annex G):

Generator:	Output reflection coefficient: $ \rho_{generator} $	= 0,30
Cable:	Input and output reflection coefficients: $ S_{11} $ and $ S_{22} $	= 0,07
	Attenuation: 1 dB = $ S_{21}  =  S_{12} $	= 0,891
EUT:	Input reflection coefficient: $ \rho_{EUT} $	= 0,4

All these contributions are U distributed. There are three contributions:

- the standard uncertainty of the mismatch between the signal generator and the cable:

$$u_{j \text{ mismatch:signal generator to cable}} = \frac{0,30 \times 0,07 \times 100\%}{\sqrt{2} \times 1,5} = 0,13 \text{ dB}$$

- the standard uncertainty of the mismatch between the cable and the EUT:

$$u_{j \text{ mismatch:cable to EUT}} = \frac{0,4 \times 0,07 \times 100\%}{\sqrt{2} \times 1,5} = 0,17 \text{ dB}$$

- the standard uncertainty of the mismatch between the signal generator and the EUT:

$$u_{j \text{ mismatch:signal generator to EUT}} = \frac{0,3 \times 0,4 \times 0,891^2 \times 100\%}{\sqrt{2} \times 1,5} = 0,59 \text{ dB}$$

- the combined standard uncertainty of the mismatch:

$$u_{c \text{ mismatch}} = \sqrt{0,13^2 + 0,17^2 + 0,59^2} = 0,63 \text{ dB}$$

$$u_{c \text{ mismatch}} = 0,63 \text{ dB}$$

The uncertainty due to the absolute output level of the signal generator is taken as  $\pm 1,0$  dB (from manufacturers data). As nothing is said about the distribution, a rectangular distribution in logs is assumed (see clause 5.1), and the standard uncertainty is:

$$u_{j \text{ signal generator level}} = 0,58 \text{ dB}$$

The uncertainty due to the output level stability of the signal generator is taken as  $\pm 0,02$  dB (from manufacturer's data). As nothing is said about the distribution, a rectangular distribution in logs is assumed (see clause 5.1), and the standard uncertainty is:

$$u_{j \text{ signal generator stability}} = 0,01 \text{ dB}$$

The uncertainty due to the insertion loss of the cable is taken as  $\pm 0,5$  dB (from calibration data). As nothing is said about the distribution, a rectangular distribution in logs is assumed, and the standard uncertainty is:

$$u_{j \text{ cable loss}} = 0,29 \text{ dB}$$

### Dependency function uncertainty calculation:

The uncertainty due to the SINAD measurement corresponds to an RF signal level uncertainty at the input of the receiving EUT.

The SINAD uncertainty from the manufacturer's data is  $\pm 1$  dB which is converted to a standard uncertainty of 0,577 dB. The dependency function converting the SINAD uncertainty to RF level uncertainty is found from ETR 028 [15], part 2, annex F, table F.1. It is given as a conversion factor of 1,0 % (level)/ % (SINAD) with an associated standard uncertainty of 0,3. The SINAD uncertainty is then converted to RF level uncertainty using formula 5.2:

$$u_{j \text{ RF level(converted)}} = \sqrt{0,577^2 \times (1,0^2 + 0,3^2)} = 0,60 \text{ dB}$$

The RF level uncertainty caused by the SINAD uncertainty and the RF level uncertainty at the input of the receiver is then combined using the square root of the sum of the squares method to give the combined standard uncertainty.

$$u_{c \text{ measurement}} = \sqrt{u_{c \text{ mismatch}}^2 + u_{j \text{ signal generator level}}^2 + u_{j \text{ signal generator stability}}^2 + u_{j \text{ cable loss}}^2 + u_{j \text{ RF level(converted)}}^2}$$

$$= \sqrt{0,63^2 + 0,58^2 + 0,01^2 + 0,29^2 + 0,60^2} = 1,08 \text{ dB}$$

The expanded uncertainty is  $\pm 1,96 \times 1,08 = \pm 2,12$  dB at a 95 % confidence level.

## 6.4 Measurement of carrier power

The example test is a conducted measurement.

### 6.4.1 Measurement set-up

The EUT is connected to the power meter via a coaxial cable and two power attenuators, one of 10 dB and one of 20 dB (see figure 9).

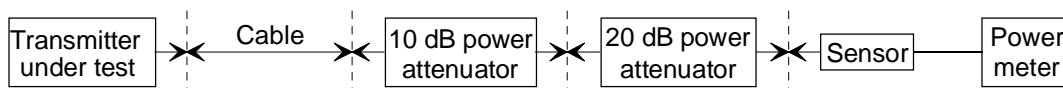

**Figure 9: Measurement set-up**

The nominal carrier power is 25 W, as a result the power level at the input of the power sensor is (nominally) 25 mW. The carrier frequency is 460 MHz and the transmitter is designed for continuous use.

### 6.4.2 Method of measurement

The transmitter is in an environmental chamber adjusted to  $+55^{\circ}\text{C}$ . The attenuators and the power sensor are outside the chamber.

Prior to the power measurement the total insertion loss of cable and attenuators is measured.

The attenuation measurements are done using a generator and a measuring receiver and two 6 dB attenuators with small VSWR.

Also the power sensor is calibrated using the built in power reference.

The result of the measurement is the power found as the average value of 9 readings from the power meter, corrected for the measured insertion loss.

### 6.4.3 Power meter and sensor module

The power meter uses a thermocouple power sensor module and contains a power reference.

#### Power reference level:

Power reference level uncertainty:  $\pm 1,2$  % power.

As nothing is stated about the distribution it is assumed to be rectangular and the standard uncertainty is converted from % power to dB by division with 23,0 (see clause 5.2).

$$\text{Standard uncertainty } u_{j \text{ referencelevel}} = \frac{1,2}{\sqrt{3} \times 23,0} = 0,030 \text{ dB}.$$

#### Mismatch whilst measuring the reference:

Reference source VSWR: 1,05 (d):  $\rho_{\text{reference source}} = 0,024$ ;

Power sensor VSWR: 1,15 (d):  $\rho_{\text{load}} = 0,07$ .

Using formula 6.3 the standard uncertainty of the mismatch is:

$$u_{j \text{ mismatch:reference}} = \frac{0,024 \times 0,07 \times 100\%}{\sqrt{2} \times 11,5} = 0,010 \text{ dB}$$

#### Calibration factors:

Calibration factor uncertainty =  $\pm 2,3$  % power.

As nothing is stated about the distribution it is assumed to be rectangular. The standard uncertainty is converted from % power to dB by division with 23,0.

$$\text{standard uncertainty } u_{j \text{ calibration factor}} = \frac{2,3}{\sqrt{3} \times 23,0} = 0,058 \text{ dB}$$

#### Range to range change:

Range to range uncertainty (one change) =  $\pm 0,5$  % power.

As nothing is stated about the distribution it is assumed to be rectangular. The standard uncertainty is converted from % power to dB by division with 23,0.

$$\text{standard uncertainty } u_{j \text{ rangechange}} = \frac{0,25}{\sqrt{3} \times 23,0} = 0,006 \text{ dB}$$

Noise and drift is negligible at this power level and can be ignored.

#### Combined standard uncertainty of the power meter and sensor:

Using formula 5.1:

$$u_{c \text{ meter and sensor}} = \sqrt{u_{j \text{ referencelevel}}^2 + u_{j \text{ mismatch:reference}}^2 + u_{j \text{ calibration factor}}^2 + u_{j \text{ rangechange}}^2}$$

$$u_{c \text{ meter and sensor}} = \sqrt{0,03^2 + 0,010^2 + 0,058^2 + 0,006^2} = 0,066 \text{ dB}$$



## 6.4.4 Attenuator and cabling network

Standing wave ratios involved in the attenuation measurement (taken from manufacturers data):

- Signal generator:  $VSWR \leq 1,5$        $\rho = 0,200$
- Power sensor:  $VSWR \leq 1,15$        $\rho = 0,070$
- 6 dB attenuators:  $VSWR \leq 1,2$        $\rho = 0,091$
- 10 dB power attenuator:  $VSWR \leq 1,3$        $\rho = 0,130$
- 20 dB attenuator:  $VSWR \leq 1,25$        $\rho = 0,111$
- Cable:  $VSWR \leq 1,2$        $\rho = 0,091$

Nominal attenuations converted to linear values:

- 6 dB =  $|S_{21}| = |S_{12}| = 0,500$ ;
- 10 dB =  $|S_{21}| = |S_{12}| = 0,316$ ;
- 20 dB =  $|S_{21}| = |S_{12}| = 0,100$ ;
- 0,3 dB =  $|S_{21}| = |S_{12}| = 0,966$  (assumed cable attenuation in the uncertainty calculations).

The attenuation measurement is carried out using a signal generator and a measuring receiver. In order to have a low VSWR two 6 dB attenuators with low reflection coefficients are inserted.

The measurement of the attenuation in the attenuator and cabling network is carried out by making a reference measurement (figure 10). The measurement receiver reading is "A" dBm.

Then the cables and the attenuators are inserted. First the cable and the 10 dB power attenuator is inserted between the two 6 dB attenuators, and a new reading "B" dBm is recorded (see figure 11).

Finally the 20 dB attenuator is inserted between the two 6 dB attenuators, and the reading "C" dBm is recorded (see figure 12).

The total attenuation is then ("A"- "B") dB + ("A"- "C") dB.

### 6.4.4.1 Reference measurement

Figure 10 details the components involved in this reference measurement.

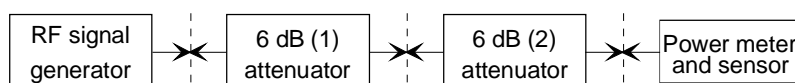

**Figure 10: The reference measurement**

The individual mismatch uncertainties between the various components in figure 10 are calculated using formula 6.3:

- the standard uncertainty of the mismatch between the signal generator and 6 dB attenuator (1):

$$u_{j \text{ mismatch: generator to 6dBatt.1}} = \frac{0,2 \times 0,091 \times 100\%}{\sqrt{2} \times 11,5} = 0,112 \text{ dB}$$

- the standard uncertainty of the mismatch between the 6 dB attenuator (1) and 6 dB attenuator (2):

$$u_{j \text{ mismatch: 6dBatt.1 to 6dBatt.2}} = \frac{0,091 \times 0,091 \times 100\%}{\sqrt{2} \times 11,5} = 0,051 \text{ dB}$$

- the standard uncertainty of the mismatch between the 6 dB attenuator (2) and power sensor:

$$u_{j \text{ mismatch:6dBatt.to power sensor}} = \frac{0,091 \times 0,07 \times 100\%}{\sqrt{2} \times 1,5} = 0,039 \text{ dB}$$

- the standard uncertainty of the mismatch between the signal generator and 6 dB attenuator (2):

$$u_{j \text{ mismatch:generatorto6dBatt.2}} = \frac{0,2 \times 0,091 \times 0,5^2 \times 100\%}{\sqrt{2} \times 1,5} = 0,028 \text{ dB}$$

- the standard uncertainty of the mismatch between the 6 dB attenuator (1) and power sensor:

$$u_{j \text{ mismatch:6dBatt.1to power sensor}} = \frac{0,091 \times 0,07 \times 0,5^2 \times 100\%}{\sqrt{2} \times 1,5} = 0,010 \text{ dB}$$

- the standard uncertainty of the mismatch between the signal generator and power sensor:

$$u_{j \text{ mismatch:generatorto power sensor}} = \frac{0,2 \times 0,07 \times 0,5^2 \times 0,5^2 \times 100\%}{\sqrt{2} \times 1,5} = 0,005 \text{ dB}$$

It can be seen that the mismatch uncertainty between the RF signal generator and the 6 dB attenuator (1)  $u_{j \text{ generator to 6 dB att. 1}}$ , and the mismatch uncertainty between the 6 dB attenuator (2) and the power sensor  $u_{j \text{ 6 dB att. 2 to power sensor}}$ , add to both the reference measurement and the measurements with the unknown attenuators inserted.

It is the result of the methodology adopted in annex D that these terms cancel and hence do not contribute to the combined standard uncertainty of the final result. The reference measurement mismatch uncertainty  $u_{j \text{ mismatch: reference}}$  (formula 5.1):

$$u_{j \text{ mismatch:reference}} = \sqrt{u_{j \text{ 6dBatt.1to6dBatt.2}}^2 + u_{j \text{ generatorto6dBatt.2}}^2 + u_{j \text{ 6dBatt.1to power sensor}}^2 + u_{j \text{ generatorto power sensor}}^2}$$

$$u_{j \text{ mismatch:reference}} = \sqrt{0,051^2 + 0,028^2 + 0,010^2 + 0,005^2} = 0,059 \text{ dB}$$

NOTE: If the two uncertainties of the generator and the power sensor did not cancel due to the methodology, the calculated reference measurement uncertainty would have been 0,131 dB.

#### 6.4.4.2 The cable and the 10 dB power attenuator

Figure 11 shows the clause of the reference set-up which concerns this part of the calculation.

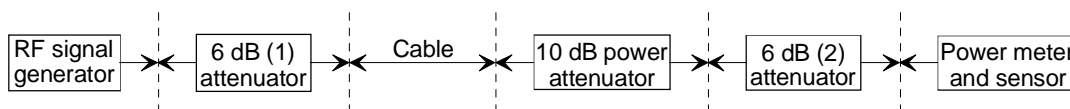

**Figure 11: The cable and the 10 dB power attenuator**

The individual uncertainties are calculated using formula 6.3:

- the standard uncertainty of the mismatch between the signal generator and 6 dB attenuator (1):

$$u_{j \text{ mismatch:generatorto6dBatt.1}} = \frac{0,2 \times 0,091 \times 100\%}{\sqrt{2} \times 1,5} = 0,112 \text{ dB}$$

- the standard uncertainty of the mismatch between the 6 dB attenuator (1) and cable:

$$u_{j \text{ mismatch:6dBatt.1tocable}} = \frac{0,091 \times 0,091 \times 100\%}{\sqrt{2} \times 1,5} = 0,051 \text{ dB}$$

- the standard uncertainty of the mismatch between the cable and 10 dB power attenuator:

$$u_{j \text{ mismatch:cableto10dBatt.}} = \frac{0,091 \times 0,130 \times 100\%}{\sqrt{2} \times 11,5} = 0,073 \text{ dB}$$

- the standard uncertainty of the mismatch between the 10 dB attenuator and the 6 dB attenuator (2):

$$u_{j \text{ mismatch:10dBatt.to6dBatt.2}} = \frac{0,130 \times 0,091 \times 100\%}{\sqrt{2} \times 11,5} = 0,073 \text{ dB}$$

- the standard uncertainty of the mismatch between the 6 dB attenuator (2) and power sensor:

$$u_{j \text{ mismatch:6dBatt.to power sensor}} = \frac{0,091 \times 0,07 \times 100\%}{\sqrt{2} \times 11,5} = 0,039 \text{ dB}$$

- the standard uncertainty of the mismatch between the signal generator and cable:

$$u_{j \text{ mismatch:generatortocable}} = \frac{0,200 \times 0,091 \times 0,5^2 \times 100\%}{\sqrt{2} \times 11,5} = 0,028 \text{ dB}$$

- the standard uncertainty of the mismatch between the 6 dB attenuator (1) and 10 dB power attenuator:

$$u_{j \text{ mismatch:6dBatt.1to10dBatt.}} = \frac{0,091 \times 0,130 \times 0,966^2 \times 100\%}{\sqrt{2} \times 11,5} = 0,068 \text{ dB}$$

- the standard uncertainty of the mismatch between the cable and 6 dB attenuator (2):

$$u_{j \text{ mismatch:cableto6dBatt.2}} = \frac{0,091 \times 0,091 \times 0,316^2 \times 100\%}{\sqrt{2} \times 11,5} = 0,005 \text{ dB}$$

- the standard uncertainty of the mismatch between the 10 dB power attenuator and the power sensor:

$$u_{j \text{ mismatch:10dBatt.to power sensor}} = \frac{0,130 \times 0,070 \times 0,500^2 \times 100\%}{\sqrt{2} \times 11,5} = 0,014 \text{ dB}$$

- the standard uncertainty of the mismatch between the signal generator and 10 dB power attenuator:

$$u_{j \text{ mismatch:generatorto10dBatt.}} = \frac{0,200 \times 0,130 \times 0,500^2 \times 0,966^2 \times 100\%}{\sqrt{2} \times 11,5} = 0,037 \text{ dB}$$

- the standard uncertainty of the mismatch between the 6 dB attenuator (1) and 6 dB attenuator (2):

$$u_{j \text{ mismatch:6dBatt.1to6dBatt.2}} = \frac{0,091 \times 0,091 \times 0,966^2 \times 0,316^2 \times 100\%}{\sqrt{2} \times 11,5} = 0,005 \text{ dB}$$

- the standard uncertainty of the mismatch between the cable and power sensor:

$$u_{j \text{ mismatch:cableto power sensor}} = \frac{0,091 \times 0,070 \times 0,316^2 \times 0,500^2 \times 100\%}{\sqrt{2} \times 11,5} = 0,001 \text{ dB}$$

- the standard uncertainty of the mismatch between the signal generator and 6 dB attenuator (2):

$$u_{j \text{ mismatch:generatorto6dBatt.2}} = \frac{0,200 \times 0,091 \times 0,500^2 \times 0,966^2 \times 0,316^2 \times 100\%}{\sqrt{2} \times 11,5} = 0,003 \text{ dB}$$

- the standard uncertainty of the mismatch between the 6 dB attenuator (1) and power sensor:

$$u_{j \text{ mismatch:6dBAtt.1to power sensor}} = \frac{0,091 \times 0,070 \times 0,966^2 \times 0,316^2 \times 0,500^2 \times 100\%}{\sqrt{2} \times 1,5} = 0,001 \text{ dB}$$

- the standard uncertainty of the mismatch between the signal generator and power sensor:

$$u_{j \text{ mismatch:generatorto power sensor}} = \frac{0,200 \times 0,070 \times 0,500^2 \times 0,966^2 \times 0,316^2 \times 0,500^2 \times 100\%}{\sqrt{2} \times 1,5} = 0,000 \text{ dB}$$

The combined mismatch uncertainty when measuring the power level when the cable and the 10 dB power attenuator is inserted is the RSS of all these components except  $u_{j \text{ mismatch: generator to 6 dB attenuator}}$  and  $u_{j \text{ mismatch: 6 dB attenuator to power sensor}}$ :

$$u_{c \text{ mismatch:10dBand cable}} = \sqrt{u_{j \text{ mismatch:6dBAtt.1tocable}}^2 + \dots + u_{j \text{ mismatch:generatorto power sensor}}^2}$$

$$u_{c \text{ mismatch:10dBand cable}} = \sqrt{0,051^2 + 0,073^2 + \dots + 0,001^2 + 0,000^2} = 0,142 \text{ dB}$$

The combined standard uncertainty of the mismatch when measuring the 10 dB attenuator and cable is:

$$u_{c \text{ mismatch:10dBand cable measurement}} = \sqrt{u_{c \text{ mismatch:10dBAttand cable}}^2 + u_{c \text{ mismatch:reference}}^2}$$

$$u_{c \text{ mismatch:10dBand cable measurement}} = \sqrt{0,142^2 + 0,059^2} = 0,154 \text{ dB}$$

The combined standard uncertainty of the mismatch  $u_{c \text{ mismatch: 10 dB and cable}}$  is 0,154 dB.

NOTE: The result would have been the same if only the 6 dominant terms were taken into account. This illustrates that combinations of reflection coefficients separated by attenuations of 10 dB or more can normally be neglected. The exceptions may be in cases where one or both of the reflection coefficients involved are approaching 1,0 - which can be the case with filters or antennas outside their working frequencies.

#### 6.4.4.3 The 20 dB attenuator

Figure 12 shows the clause of the set-up which concerns this part of the calculation.

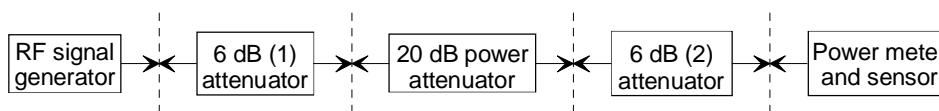

Figure 12: The 20 dB attenuator

In this part only terms separated by less than 10 dB are taken into account.

The individual uncertainties are calculated using formula 6.3:

- the standard uncertainty of the mismatch between the signal generator and 6 dB attenuator (1):

$$u_{j \text{ mismatch:generatorto6dBAtt.}} = \frac{0,2 \times 0,091 \times 100\%}{\sqrt{2} \times 1,5} = 0,112 \text{ dB}$$

- the standard uncertainty of the mismatch between the 6 dB attenuator (1) and 20 dB attenuator:

$$u_{j \text{ mismatch:6dBAtt.1to20dBAtt.}} = \frac{0,091 \times 0,111 \times 100\%}{\sqrt{2} \times 1,5} = 0,062 \text{ dB}$$

- the standard uncertainty of the mismatch between the 20 dB attenuator and 6 dB attenuator (2):

$$u_{j \text{ mismatch:20dBatt.to6dBatt.2}} = \frac{0,11 \times 0,091 \times 100\%}{\sqrt{2} \times 11,5} = 0,062 \text{ dB}$$

- the standard uncertainty of the mismatch between the 6 dB attenuator (2) and power sensor:

$$u_{j \text{ mismatch:6dBatt.to power sensor}} = \frac{0,091 \times 0,07 \times 100\%}{\sqrt{2} \times 11,5} = 0,039 \text{ dB}$$

- the standard uncertainty of the mismatch between the signal generator and 20 dB attenuator:

$$u_{j \text{ mismatch:generaorto20dBatt.}} = \frac{0,200 \times 0,111 \times 0,500^2 \times 100\%}{\sqrt{2} \times 11,5} = 0,034 \text{ dB}$$

- the standard uncertainty of the mismatch between the 20 dB attenuator and power sensor:

$$u_{j \text{ mismatch:20dBatt.to power sensor}} = \frac{0,111 \times 0,070 \times 0,500^2 \times 100\%}{\sqrt{2} \times 11,5} = 0,012 \text{ dB}$$

The rest of the combinations are not taken into account because the insertion losses between them are so high, that the values are negligible:

- 6 dB attenuator (1) and 6 dB attenuator (2);
- signal generator and 6 dB attenuator (2);
- 6 dB attenuator (1) and measuring receiver;
- signal generator and measuring receiver.

The combined standard uncertainty of the mismatch when measuring the attenuation of the 20 dB attenuator is the RSS of these 4 individual standard uncertainty values:

$$u_{j \text{ mismatch:20dB}} = \sqrt{0,062^2 + 0,062^2 + 0,034^2 + 0,012^2} = 0,095 \text{ dB}$$

The combined standard uncertainty of the mismatch involved in the 20 dB attenuator measurement is:

$$u_{c \text{ mismatch:20dBmeasurement}} = \sqrt{u_{c \text{ mismatch:20dB}}^2 + u_{c \text{ mismatch:reference}}^2}$$

$$u_{c \text{ mismatch:20dBmeasurement}} = \sqrt{0,095^2 + 0,059^2} = 0,112 \text{ dB}$$

NOTE: If the two 6 dB attenuators had not been inserted, the result would have been 0,265 dB.

#### 6.4.4.4 Instrumentation

Linearity of the measuring receiver is  $\pm 0,04$  dB (from manufacturers data) as nothing is said about the distribution, a rectangular distribution in logs is assumed and the standard uncertainty is calculated:

$$\text{standard uncertainty } u_{j \text{ receiverlinearity}} = \frac{0,04}{\sqrt{3}} = 0,023 \text{ dB}$$

#### 6.4.4.5 Power and temperature influences

Temperature influence: 0,0001 dB/degree (from manufacturers data), which is negligible, the power influence for the 10 dB attenuator is 0,0001 dB/dB  $\times$  Watt (from manufacturers data) which gives  $0,0001 \times 25 \times 10 = 0,025$  dB as nothing is said about the distribution, a rectangular distribution in logs is assumed and the standard uncertainty is calculated:

$$u_{j \text{ power influence } 10\text{dB}} = \frac{0,025}{\sqrt{3}} = 0,014 \text{ dB}$$

The power influence for the 20 dB attenuator is 0,001 dB/dB  $\times$  Watt (from manufacturers data) which gives  $0,001 \times 2,5 \times 20 = 0,05$  dB as nothing is said about the distribution, a rectangular distribution in logs is assumed and the standard uncertainty is calculated:

$$u_{j \text{ power influence } 20\text{dB}} = \frac{0,050}{\sqrt{3}} = 0,028 \text{ dB}$$

#### 6.4.4.6 Collecting terms

10 dB attenuator and cabling network uncertainty:

$$u_{c \text{ 10dBattenuatorandcable}} = \sqrt{u_{c \text{ mismatch}}^2 + u_{j \text{ receiverlinearity}}^2 + u_{j \text{ power influence } 10\text{dB}}^2}$$

$$u_{c \text{ 10dBattenuatorandcable}} = \sqrt{0,154^2 + 0,023^2 + 0,014^2} = 0,156 \text{ dB}$$

20 dB attenuator and cabling network uncertainty:

$$u_{c \text{ 20dBattenuator}} = \sqrt{u_{c \text{ mismatch}}^2 + u_{j \text{ receiverlinearity}}^2 + u_{j \text{ power influence } 20\text{dB}}^2}$$

$$u_{c \text{ 20dBattenuator}} = \sqrt{0,112^2 + 0,04^2 + 0,028^2} = 0,122 \text{ dB}$$

The combined standard uncertainty of the attenuator and cabling network uncertainty:

$$u_{c \text{ attenuationandcabling}} = \sqrt{u_{c \text{ 10dBattenuatorandcable}}^2 + u_{c \text{ 20dBattenuator}}^2}$$

$$u_{c \text{ attenuationandcabling}} = \sqrt{0,160^2 + 0,122^2} = 0,201 \text{ dB}$$

#### 6.4.5 Mismatch during measurement

Standing wave ratios involved in the power measurement:

- EUT:  $\rho = 0,500$ ;
- Power sensor: VSWR  $\leq 1,15$   $\rho = 0,070$ ;
- 10 dB power attenuator: VSWR  $\leq 1,3$   $\rho = 0,130$ ;
- 20 dB attenuator: VSWR  $\leq 1,25$   $\rho = 0,111$ ;
- Cable: VSWR  $\leq 1,2$   $\rho = 0,091$ .

The mismatch uncertainties are calculated using formula 6.3 for the individual mismatch uncertainties between:

- the standard uncertainty of the mismatch between the EUT and cable:

$$u_{j \text{ mismatch:EUT to cable}} = \frac{0,200 \times 0,091 \times 100\%}{\sqrt{2} \times 11,5} = 0,112 \text{ dB}$$

- the standard uncertainty of the mismatch between the cable and 10 dB power attenuator:

$$u_{j \text{ mismatch:cable to 10 dBatt.}} = \frac{0,091 \times 0,130 \times 100\%}{\sqrt{2} \times 11,5} = 0,073 \text{ dB}$$

- the standard uncertainty of the mismatch between the 10 dB power attenuator and 20 dB attenuator:

$$u_{j \text{ mismatch:10 dBatt. to 20 dBatt.}} = \frac{0,130 \times 0,111 \times 100\%}{\sqrt{2} \times 11,5} = 0,089 \text{ dB}$$

- the standard uncertainty of the mismatch between the 20 dB attenuator and power sensor:

$$u_{j \text{ mismatch:20 dBatt. to power sensor}} = \frac{0,111 \times 0,070 \times 100\%}{\sqrt{2} \times 11,5} = 0,048 \text{ dB}$$

- the standard uncertainty of the mismatch between the EUT and 10 dB power attenuator:

$$u_{j \text{ mismatch:EUT to 10 dBatt.}} = \frac{0,200 \times 0,130 \times 0,966^2 \times 100\%}{\sqrt{2} \times 11,5} = 0,149 \text{ dB}$$

- the standard uncertainty of the mismatch between the cable and 20 dB attenuator:

$$u_{j \text{ mismatch:cable to 20 dBatt.}} = \frac{0,091 \times 0,111 \times 0,966^2 \times 0,316^2 \times 100\%}{\sqrt{2} \times 11,5} = 0,058 \text{ dB}$$

- the standard uncertainty of the mismatch between the EUT and 20 dB attenuator:

$$u_{j \text{ mismatch:EUT to 20 dBatt.}} = \frac{0,200 \times 0,111 \times 0,966^2 \times 0,316^2 \times 100\%}{\sqrt{2} \times 11,5} = 0,013 \text{ dB}$$

The rest of the combinations:

- 10 dB attenuator to power sensor;
- cable to power sensor;
- EUT to power sensor;

are neglected. The combined standard uncertainty of the mismatch during the measurement is the RSS of the individual components:

$$u_{c \text{ mismatch}} = \sqrt{0,112^2 + 0,073^2 + 0,089^2 + 0,048^2 + 0,149^2 + 0,058^2 + 0,013^2} = 0,232 \text{ dB}$$

In the case where all contributions are considered as independent.

## 6.4.6 Influence quantities

The two influence quantities involved in the measurement are ambient temperature and supply voltage.

Temperature uncertainty:  $\pm 1,0^\circ\text{C}$ .

Supply voltage uncertainty:  $\pm 0,1 \text{ V}$ .

Uncertainty caused by the temperature uncertainty: Dependency function (from ETR 028 [15], part 2, annex F, table F.1): Mean value 4 %/°C and standard deviation: 1,2 %/°C.

Standard uncertainty of the power uncertainty caused by ambient temperature uncertainty (formula 5.2; see also annex D, clause D.4.2.1 in part 2).

$$u_{j\text{ power / temperature}} = \frac{1}{23,0} \sqrt{\frac{1,0^2}{3} (4,0^2 + 1,2^2)} = 0,105 \text{ dB}$$

Uncertainty caused by supply voltage uncertainty: Dependency function (from ETR 028 [15]: part 2: annex F: table F.1): Mean: 10 %/V and standard deviation: 3 %/V power, Standard uncertainty of the power uncertainty caused by power supply voltage uncertainty (formula 5.2; see also annex D, clause D.4.2.1 in part 2).

$$u_{j\text{ power / voltage}} = \frac{1}{23,0} \sqrt{\frac{0,1^2}{3} (10^2 + 3^2)} = 0,026 \text{ dB}$$

$$u_{\text{influence}} = \sqrt{u_{j\text{ power / temperature}}^2 + u_{j\text{ power / voltage}}^2} = \sqrt{0,105^2 + 0,026^2} = 0,108 \text{ dB}$$

## 6.4.7 Random

The measurement was repeated 9 times The following results were obtained (before correcting for cabling and attenuator network insertion loss):

- 21,8 mW, 22,8 mW, 23,0 mW, 22,5 mW, 22,1 mW, 22,7 mW, 21,7 mW, 22,3 mW, 22,7 mW.

The two sums  $X$  and  $Y$  are calculated:

- $X$  = the sum of the measured values = 201,6 mW;
- $Y$  = the sum of the squares of the measured values = 4517,5 mW<sup>2</sup>;

$$u_{c\text{ random}} = \sqrt{\frac{Y - \frac{X^2}{n}}{n-1}} = \sqrt{\frac{4517,5 - \frac{201,6^2}{9}}{9-1}} = 0,456 \text{ mW (formula 5.5);}$$

- Mean value = 22,4 mW.

As the result is obtained as the mean value of 9 measurements the standard uncertainty (converted to dB by division with 23,0) of the random uncertainty is:

$$u_{c\text{ random}} = \frac{0,456}{22,4} \times \frac{100}{23,0} = 0,089 \text{ dB}$$

NOTE: It is important to try and identify whether this value corresponds to the effect of other uncertainties, already taken into account in the calculations (e.g. uncertainties due to the instrumentation), or whether this corresponds to a genuine contribution (in which cas it has to be combined with all the other contributions)... obviously, there are uncertainties in the measurements, so it has to be expected that performing the same measurement a number of times may provide a set of different results.

## 6.4.8 Expanded uncertainty

The combined standard uncertainty for the carrier power measurement is the RSS of all the calculated part standard uncertainties:

$$u_{c\text{ carrier power}} = \sqrt{u_{c\text{ meter and sensor}}^2 + u_{c\text{ attenuation and cabling}}^2 + u_{c\text{ mismatch}}^2 + u_{c\text{ influence}}^2 + u_{c\text{ random}}^2}$$

$$u_{c\text{ carrier power}} = \sqrt{0,066^2 + 0,201^2 + 0,232^2 + 0,108^2 + 0,089^2} = 0,344 \text{ dB}$$



The expanded uncertainty is  $\pm 1,96 \times 0,344 \text{ dB} = \pm 0,67 \text{ dB}$  at a 95 % confidence level, should the distribution corresponding to the combined uncertainty be Normal (this is further discussed in clause D.5.6 in part 2).

The dominant part of this expanded uncertainty is mismatch uncertainty. In the calculations all the mismatch uncertainties were based on manufacturers data, which are normally very conservative. The relevant reflection coefficients could be measured by means of a network analyser or reflection bridge. This would probably give lower reflection coefficients thereby reducing the overall uncertainty.

NOTE: In the case where these coefficient are measured a number of times, under conditions where it can be considered that the measurements are independent, then the comments found in clauses 5.3.1 and 6.4.7 may be relevant.

## 6.5 Uncertainty calculation for measurement of a receiver (Third order intermodulation)

Before starting we need to know the architecture and the corresponding noise behaviour of the receiver.

### 6.5.1 Noise behaviour in different receiver configurations

The effect of noise on radio receivers is very dependant on the actual design. A radio receiver has (generally) a front end and demodulation stages according to one of the possibilities presented in figure 13. This simplified diagram (for AM and FM/PM systems) illustrates several possible routes from the front end to the "usable output".

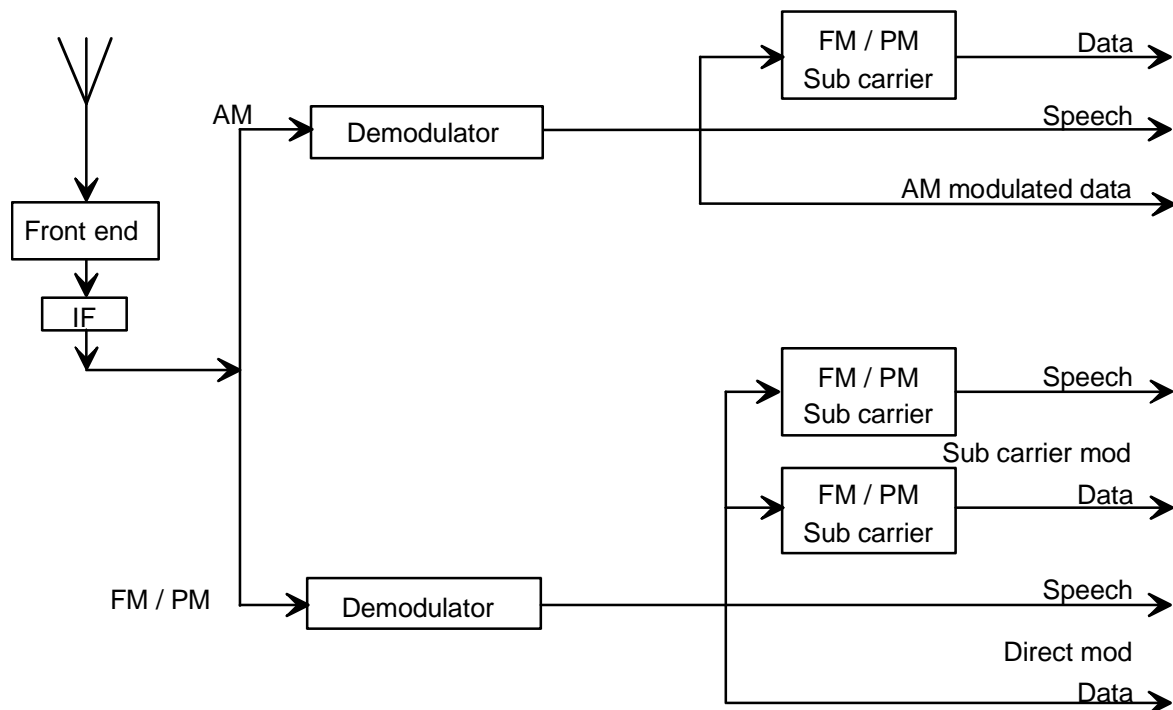

Figure 13: Possible receiver configurations

The Amplitude Modulation route involves a 1:1 conversion after the front end and the amplitude demodulation information is available immediately (analogue) or undergoes data demodulation.

The frequency modulation/phase modulation route introduces an enhancement to the noise behaviour in non-linear (e.g. FM/PM) systems compared to linear (e.g. AM) systems, see figure 14, until a certain threshold or lower limit (referred to as the knee-point) is reached. Below this knee-point the demodulator output signal to noise ratio degrades more rapidly for non-linear systems than the linear system for an equivalent degradation of the carrier to noise ratio, this gives rise to two values for the slope: one value for C/N ratios above the knee and one value for C/N ratios below the knee.

A similar difference will occur in data reception between systems which utilize AM and FM/PM data. Therefore "Noise Gradient" corresponds to several entries in ETR 028 [15], part 2, annex F, table F.1.

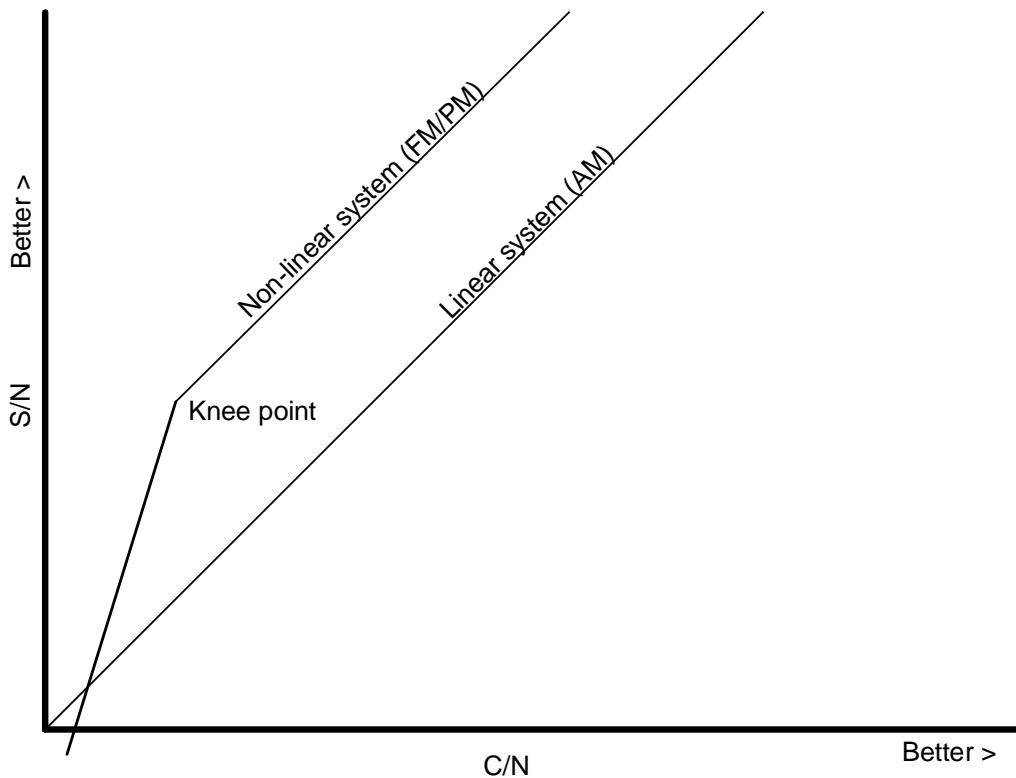

Figure 14: Noise behaviour in receivers

## 6.5.2 Sensitivity measurement

The sensitivity of a receiver is usually measured as the input RF signal level which produces a specific output performance which is a function of the base band signal-to-noise ratio in the receiver.

This is done by adjusting the RF level of the input signal at the RF input of the receiver.

What is actually done is that the RF signal-to-noise ratio at the input of the receiver is adjusted to produce a specified signal-to-noise ratio dependant behaviour at the output of the receiver, i.e. SINAD, BER, or message acceptance.

An error in the measurement of the output performance will cause a mis adjustment of the RF level and thereby the result.

In other words any uncertainty in the output performance is converted to signal-to-noise ratio uncertainty at the input of the receiver. As the noise does not change it causes an uncertainty in the adjusted level.

For an analogue receiver, the dependency function to transform the SINAD uncertainty to the RF input level uncertainty is the slope of the noise function described above in clause 6.5.1 and depends on the type of carrier modulation.

The dependency function involved when measuring the sensitivity of an FM/PM receiver is the noise behaviour usually below the knee-point for a non-linear system, in particular in the case of data equipment. This function also affects the uncertainty when measuring sensitivity of an FM/PM based data equipment.

This dependency function has been empirically derived at  $0,375 \text{ dB}_{RF \text{ i/p level}} / \text{dB}_{SINAD}$  associated with a standard uncertainty of  $0,075 \text{ dB}_{RF \text{ i/p level}} / \text{dB}_{SINAD}$  and is one of the values stated in ETR 028 [15], part 2, annex F, table F.1.

If the receiver is for data the output performance is a specified BER. BER measurements are covered by clause 6.6.

In some standards the sensitivity is measured as the output performance at a specified input level. In this case the dependency functions converting input level uncertainty to output performance uncertainty are the inverse of the functions previously described.

### 6.5.3 Interference immunity measurements

Interference immunity (i.e. co-channel rejection, adjacent channel rejection) is measured by adjusting the RF level of the wanted signal to a specified value. Then the RF level of the interfering signal is adjusted to produce a specified performance at the output of the receiver.

The interfering signal is normally modulated. Therefor for measurement uncertainty purposes it can be regarded as white noise in the receiving channel.

The uncertainty analysis is therefor covered by clause 6.5.2.

### 6.5.4 Blocking and spurious response measurements

These measurements are similar to interference immunity measurements except that the unwanted signal is without modulation.

Even though the unwanted signal (or the derived signal in the receive channel caused by the unwanted signal) can not in every case be regarded as white noise, the present document does not distinguish. The same dependency functions are used.

### 6.5.5 Third order intermodulation

When two unwanted signals  $X$  and  $Y$  occur at frequency distance  $d(X)$  and  $2d(Y)$  from the receiving channel a disturbing signal  $Z$  is generated in the receiving channel due to non linearities in filters, amplifiers and mixers.

The physical mechanism behind the intermodulation is the third order component of the non-linearity of the receiver:

$$K \times X^3$$

When two signals -  $X$  and  $Y$  - are subject to that function, the resulting function will be:

- $K(X + Y)^3 = K(X^3 + Y^3 + 3X^2Y + 3XY^2)$ , where the component  $Z = 3X^2Y$  is the disturbing intermodulation product in the receiving channel.

If  $X$  is a signal  $I_x \sin(2\pi f_o + d)t$  and  $Y$  is a signal  $I_y \sin(2\pi f_o + 2d)t$ , the component:

- $Z = K \times 3X^2Y$  will generate a signal having the frequency  $f_o$  and the amplitude  $K \times 3I_x^2 I_y$ .

(A similar signal  $Z' = 3XY^2$  is generated on the other side of the two signals  $X$  and  $Y$ , as shown in figure 15).

The predominant function is a third order function:

$$I_z = I_c + 2I_x + I_y \quad (6.4)$$

where  $I_z$  is the level of the intermodulation product  $Z$ ,  $I_c$  is a constant,  $I_x$  and  $I_y$  are the levels of  $X$  and  $Y$ . All terms are logarithmic.

#### 6.5.5.1 Measurement of third order intermodulation

The measurement is normally carried out as follows.

Three signal generators are connected to the input of the EUT.

Generator 1 is adjusted to a specified level at the receiving frequency  $f_o$  (the wanted signal  $W$ ).

Generator 2 is adjusted to frequency  $f_o + \delta$  (unwanted signal  $X$ ) and generator 3 is adjusted to frequency  $f_o + 2\delta$  (unwanted signal  $Y$ ). The level of  $X$  and  $Y$  ( $I_x$  and  $I_y$ ) are maintained equal during the measurement.

$I_x$  and  $I_y$  are increased to level  $A$  which causes a specified degradation of AF output signal (SINAD) or a specific bit error ratio (BER) or a specific acceptance ratio for messages.

Both the SINAD, BER and message acceptance ratio are a function of the signal-to-noise ratio in the receiving channel.

The level of the wanted signal  $W$  is  $A_w$  (see figure 15). The measured result is the difference between the level of the wanted signal  $A_w$  and the level of the two unwanted signals  $A$ . This is the ideal measurement.

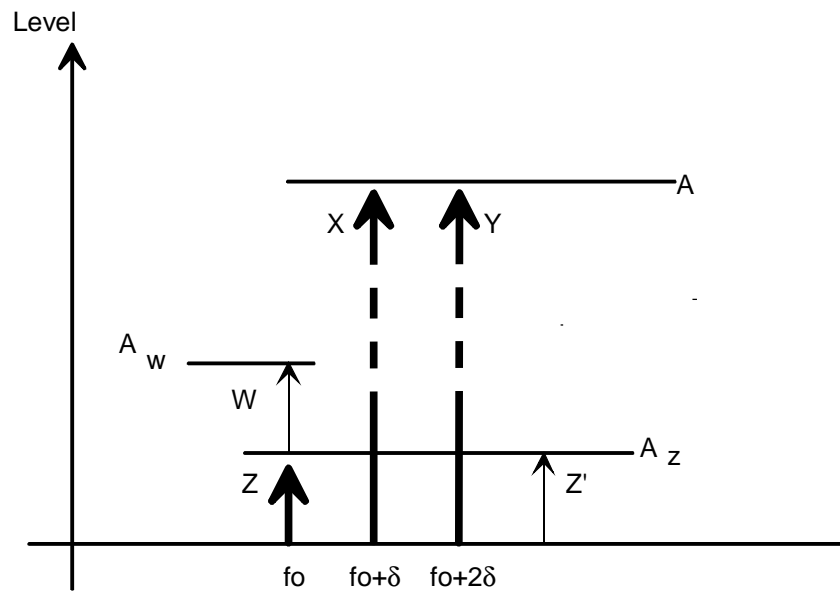

**Figure 15: Third order intermodulation components**

When looked upon in logarithmic terms a level change  $\delta_x$  dB in  $X$  will cause a level change of  $2 \times \delta_x$  dB in  $Z$ , and a level change  $\delta_y$  dB in  $Y$  will cause the same level change  $\delta_z$  dB in  $Z$ .

If the levels of both  $X$  and  $Y$  are changed by  $\delta$  dB, the resulting level change of  $Z$  is  $3 \times \delta$  dB.

Since  $X$  is subject to a second order function, any modulation on  $X$  will be transferred with double uncertainty to  $Z$  (see also annex D, clauses D.3.2, D.3.4 and D.5, in part 2), whereas the deviation of any modulation on  $Y$  will be transferred unchanged to  $Z$ .

Therefore, as  $Y$  is modulated in the measurement, the resulting modulation of  $Z$  will be the same as with  $Y$ .

### 6.5.5.2 Uncertainties involved in the measurement

The predominant uncertainty sources related to the measurement are the uncertainty of the levels of the applied RF signals and uncertainty of the degradation (the SINAD, BER, or message acceptance measurement). The problems about the degradation uncertainty are exactly the same as those involved in the co-channel rejection measurement if the intermodulation product  $Z$  in the receiving channel is looked upon as the unwanted signal in this measurement. Therefore the noise dependency is the same, but due to the third order function the influence on the total uncertainty is reduced by a factor 3 (see annex D, clauses D.3.2 and D.5, in part 2).

It is in the following assumed that the distance to the receiver noise floor is so big that the inherent receiver noise can be disregarded.

### 6.5.5.2.1 Signal level uncertainty of the two unwanted signals

A is the assumed level of the two unwanted signals (the indication of the two unwanted signal generators corrected for matching network attenuations):

- $A_x$  is the true level of X and  $A_y$  is the true level of Y. ( $A_x$  is  $A + \delta x$  and  $A_y$  is  $A + \delta y$ ) see figure 16;
- $A_z$  is the level of Z (the same as in the ideal measurement).

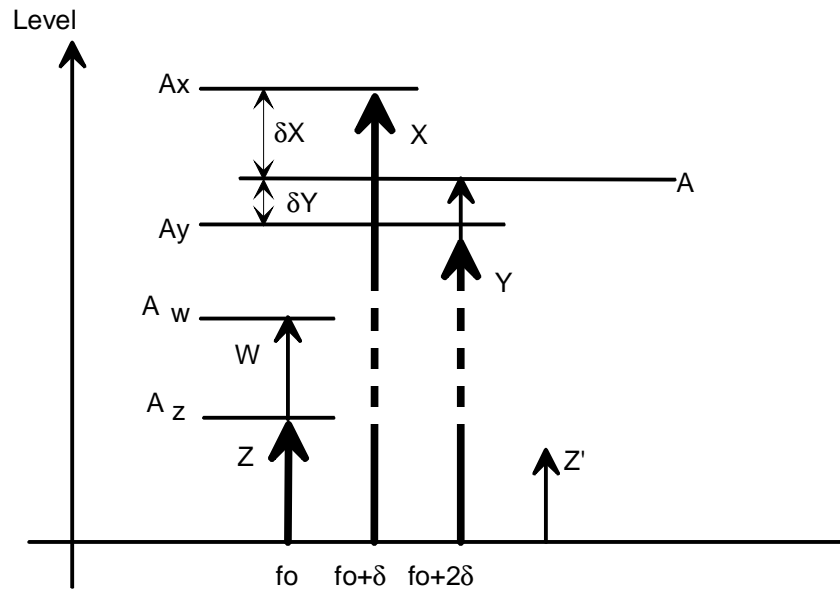

**Figure 16: Level uncertainty of two unwanted signals**

If  $A_x$  and  $A_y$  were known the correct measuring result would be obtained by adjusting the two unwanted signals to the level  $A_t$  (true value) which still caused the level  $A_z$  of Z.

If there is an error  $\delta x$  of the level of signal X, the error of the level of the intermodulation product will be  $2 \times \delta x$  (see also annex D, clauses D.3 and D.5, in part 2); to obtain the wanted signal-to-noise ratio the two unwanted levels must be reduced by  $2 \times \delta x/3$ .

In other words the dependency function of generator X is 2/3.

In the same way if there is an error  $\delta y$  of the level of signal Y, the error of the level of the intermodulation product will be  $\delta y$ ; to obtain the wanted signal-to-noise ratio the two unwanted signals must be reduced by  $\delta y/3$ .

In other words the dependency function of generator Y is 1/3.

When looking at the problem in linear terms, the dependency functions are valid for small values of  $\delta x$  and  $\delta y$  due to the fact that the higher order components of the third order function can be neglected.

$\delta x$  and  $\delta y$  are the relative RF level uncertainties at the input of the EUT. They are combinations of signal generator level uncertainty, matching network attenuation uncertainty and mismatch uncertainties at the inputs and the output of the matching network.

The standard uncertainties of the levels of X and Y are  $u_{j_x}$  and  $u_{j_y}$ .

The standard uncertainty  $u_{j_{unwanted\ signals}}$  related to the uncertainty caused by level uncertainty of the two unwanted signals is thus (see also clause D.3.2.3 of annex D, in part 2):

$$u_{j_{unwanted\ signals}} = \sqrt{\left(\frac{2}{3}u_{j_x}\right)^2 + \left(\frac{1}{3}u_{j_y}\right)^2} \quad (6.5)$$

### 6.5.5.2.2 Signal level uncertainty of the wanted signal

Under the assumption that equal change of both the level of the wanted signal and the intermodulation product will cause no change of the SINAD, (or the BER, or the message acceptance) the error contribution from the uncertainty of the level of the wanted signal can be calculated.

If there is an error  $\delta_w$  on the wanted signal, the two unwanted signal levels must be adjusted by  $1/3 \times \delta_w$  to obtain the wanted signal-to-noise ratio. The dependency function of generator  $W$  is therefore  $1/3$  and assuming the same types of uncertainties as previously the standard uncertainty,  $u_{j \text{ wanted signal}}$  is (see clause D.3.2.3 of annex D, in part 2):

$$u_{j \text{ wanted signal}} = \left( \frac{1}{3} u_{j \text{ unwanted signals}} \right) \quad (6.6)$$

### 6.5.5.3 Analogue speech (SINAD) measurement uncertainty

Sensitivity is normally stated as an RF input level in conducted measurements.

For analogue systems this is stated as at a specified SINAD value.

For an analogue receiver, the dependency function to transform the SINAD uncertainty to the RF input level uncertainty is the slope of the noise function described above in clause 6.5.1 and depends on the type of carrier modulation.

The dependency function involved when measuring the sensitivity of an FM/PM receiver is the noise behaviour usually below the knee-point for a non-linear system, in particular in the case of data equipment. This function also affects the uncertainty when measuring sensitivity of an FM/PM based data equipment.

This dependency function has been empirically derived at  $0,375 \text{ dB}_{RF \text{ i/p level}} / \text{dB}_{SINAD}$  associated with a standard uncertainty of  $0,075 \text{ dB}_{RF \text{ i/p level}} / \text{dB}_{SINAD}$  and is one of the values stated in ETR 028 [15], part 2, annex F, table F.1.

The SINAD measurement uncertainty also contributes to the total measurement uncertainty.

If the receiver is working beyond the demodulator knee point any SINAD uncertainty corresponds to an equal uncertainty (in dB) of the signal-to-noise ratio.

If the receiver is working below the knee point the corresponding uncertainty of the signal-to-noise ratio will be in the order of  $1/3$  times the SINAD uncertainty (according to ETR 028 [15], part 2, annex F, table F.1).

Any signal-to-noise ratio uncertainty causes  $1/3$  times that uncertainty in the combined uncertainty: the unwanted signal levels must be adjusted by  $1/3$  of the signal-to-noise ratio error to obtain the correct value.

Therefore if the receiver is working above the knee point the SINAD dependency function is  $1/3$ , and if the receiver is working below the knee point the dependency function is in the order of  $1/9$ .

### 6.5.5.4 BER and message acceptance measurement uncertainty

Any BER (or message acceptance) uncertainty will influence the total uncertainty by the inverse of the slope of the appropriate BER function at the actual signal-to-noise ratio.

As the BER function is very steep, the resulting dependency function is small, and it is sufficient to use the differential coefficient as an approximation.

If the signalling is on a sub carrier, the relation between the signal-to-noise ratio of the sub carrier must be dealt with in the same way as with other receiver measurements. See clause 6.6.3.

### 6.5.5.5 Other methods of measuring third order intermodulation

Some test specifications specify other methods of measuring the intermodulation rejection.

The measured result is the SINAD, BER, or message acceptance at **fixed** test signal levels. This is the case with some digital communication equipment like DECT and GSM.

In these measurements the uncertainty must be calculated in 3 steps:

- 1) the uncertainty of the resulting signal-to-noise ratio is calculated;
- 2) this uncertainty is then applied to the appropriate SINAD, BER, or message acceptance function;
- 3) and then combined with the measurement uncertainty of the SINAD, BER, or message acceptance measurement.

The uncertainty of the signal-to-noise ratio due to uncertainty of the level of the test signals is:

$$u_{j\text{SNR}} = \sqrt{(2u_{jx})^2 + u_{jy}^2 + u_{jw}^2}$$

This uncertainty is then transformed to the measured parameter.

If the measured value is a SINAD value and the receiver is working beyond the knee point the SINAD uncertainty is identical, but if the receiver is working below the knee point the dependency function is in the order of 3,0.

If the measurand is a BER or a message acceptance, the dependency function is too non linear to be regarded as a first order function.

The total uncertainty must then be calculated as described in clause 6.6.4.3.

## 6.6 Uncertainty in measuring continuous bit streams

### 6.6.1 General

If an EUT is equipped with data facilities, the characteristic used to assess its performance is the Bit Error Ratio (BER).

The BER is the ratio of the number of bits in error to the total number of bits in a received signal and is a good measure of receiver performance in digital radio systems just as SINAD is a good measure of receiver performance in analogue radios. BER measurements, therefore, are used in a very similar way to SINAD measurements, particularly in sensitivity and immunity measurements.

### 6.6.2 Statistics involved in the measurement

Data transmissions depend upon a received bit actually being that which was transmitted. As the level of the received signal approaches the noise floor (and therefore the signal to noise ratio decreases), the probability of bit errors (and the BER) increases.

The first assumption for this statistical analysis of BER measurements is that each bit received (with or without error) is independent of all other bits received. This is a reasonable assumption for measurements on radio equipment, using binary modulation, when measurements are carried out in steady state conditions. If, for instance, fading is introduced, it is not a reasonable assumption.

The measurement of BER is normally carried out by comparing the received data with that which was actually transmitted. The statistics involved in this measurement can be studied using the following population of stones: one black and (1/BER)-1 white stones. If a stone is taken randomly from this population, its colour recorded and the stone replaced  $N$  times, the black stone ratio can be defined as the number of occurrences of black stones divided by  $N$ . This is equivalent to measuring BER.

The statistical distribution for this measurement is the binomial distribution. This is valid for discrete events and gives the probability that  $x$  samples out of the  $N$  stones sampled are black stones (or  $x$  bits out of  $N$  received bits are in error) given the BER:

$$P(x) = \frac{N!}{x!(N-x)!} \times BER^x (1-BER)^{N-x} \quad (6.7)$$

The mean value of this distribution is  $BER \times N$  and the standard deviation is:

$$\sqrt{BER \times (1-BER)} \times \sqrt{N} \quad (6.8)$$

and for large values of  $N$  the shape of the distribution approximates a Gaussian distribution.

Normalizing the mean value and standard uncertainty (by dividing by  $N$ ) gives:

$$\text{Mean value} = BER \quad (6.9)$$

$$u_{jBER} = \sqrt{\frac{BER(1-BER)}{N}} \quad (6.10)$$

From these two formulas it is easy to see that the larger number of bits, the smaller the random uncertainty, and the relation between number of bits and uncertainty is the same as for random uncertainty in general. By means of formula 6.11 it is possible to calculate the number of bits needed to be within a specific uncertainty.

For example: A BER in the region of 0,01 is to be measured.

- a) If the standard uncertainty, due to the random behaviour discussed above, is to be 0,001, then the number of bits to be compared,  $N$ , in order to fulfil this demand is calculated from the rearranged formula (6.11).

$$N = \frac{BER(1-BER)}{u_{jBER}^2} = \frac{0,01 \times 0,99}{0,001^2} = 9900$$

- b) If the number of bits compared,  $N$ , is defined, e.g. 2 500 then the standard uncertainty is given directly by formula (6.11).

$$u_{jBER} = \sqrt{\frac{0,01(1-0,01)}{2500}} = 0,002$$

As stated earlier the binomial distribution can be approximated by a Normal distribution. This is not true when the BER is so small that only a few bit errors ( $< 10$ ) are detected within a number of bits. In this case the binomial distribution is skewed as the  $p$  ( $BER < 0$ ) = 0.

Another problem that occurs when only few bit errors are detected, and the statistical uncertainty is the dominant uncertainty (which does not happen in PMR measurements, but it does, due to the method, occur in DECT and GSM tests) is that the distribution of the true value about the measured value can be significantly different from an assumed Normal distribution.

### 6.6.3 Calculation of uncertainty limits when the distribution characterizing the combined standard uncertainty cannot be assumed to be a Normal distribution

In the calculations of uncertainty there is usually no distinction between the distribution of a measured value about the true value, and the distribution of the true value about a measured value. The assumption is that they are identical.

This is true in the cases where the standard uncertainty for the distribution of the measured value about the true value is independent of the true value - which usually is the case. But if the standard uncertainty is a function of the true value of the measurand (**not** the measured value), the resulting distribution of the measurement uncertainty will not be a Normal distribution even if the measured value about the true value is.

This is illustrated by the following (exaggerated) example.



A DC voltage is to be measured. We assume that there is only one uncertainty contribution which comes from the voltmeter used for the measurement.

In the manufacturers data sheet for the voltmeter it is stated that the measured value is within  $\pm 25\%$  of the true value.

If the true value is 1,00 V then the measured value lies between 0,75 V and 1,25 V. However, if the measured value is 0,75 V and the true value is still 1,00 V corresponding to 1,3333 times the measured value. Similarly, If the measured value is 1,25 V and the true value is still 1,0 V this corresponds to 0,8 times the measured value.

Therefore the limits are asymmetric for the true value about the measured value (-20 % and +33,33 %).

When looking at the standard deviations, the error introduced is small. In the previous example the standard deviation of the measured value about the true value is 14,43 %. The standard deviation of the related true value about the measured value is 15,36 %. As the difference is small, and the distribution of the measured value about the true value is based on an assumption anyway, the present document suggests that it can be used directly.

NOTE: The average value, however, is no longer zero, but in this case is approximately 4,4 %.

Alternatively, also in this example,  $x_t$  is the true value and  $x_m$  is the measured value. Any parameter printed in square brackets, e.g.  $[x_m]$ , is considered to be constant.

The distribution of the measured value  $x_m$  about the true value  $x_t$  is given by the function  $p(x_m, [x_t])$ .

Based on this function the distribution  $p1(x_t, [x_m])$  of the true value  $x_t$  about the measured value  $x_m$  can be derived.

The intermediate function is  $p(x_t, [x_m])$  which is the same as the previous; the only difference being that  $x_t$  is the variable and  $x_m$  is held constant. This function is not a probability distribution as the integral from  $-\infty$  to  $+\infty$  is not unity. To be converted to the probability function  $p1(x_t, [x_m])$  it must be normalized. Therefore:

$$p1(x_t, [x_m]) = \frac{p(x_t, [x_m])}{\int_{-\infty}^{\infty} p(x, [x_m]) dx} \quad (6.11)$$

As this distribution is not Normal, the uncertainty limits must be found by other means than by multiplication with a coverage factor from Student's t-distribution. How the actual limits are calculated in practise depends on the actual distribution.

An example: If the true BER of a radio is  $5 \times 10^{-6}$  and the BER is measured over  $10^6$  bits, the probability of detecting 0 bits is 0,674 %. On the other hand if the BER in a measurement is measured as  $5 \times 10^{-6}$  the true value cannot be 0.

If the uncertainty calculations are based on the assumption of a Gaussian distribution, the lower uncertainty limit becomes negative (which of course doesn't reflect reality, and provides the evidence that not all distributions are Normal!).

The standard uncertainty based on the measured value  $3,0 \times 10^{-6}$ :

$$u_j = \sqrt{\frac{3,0 \times 10^{-6} (1 - 3,0 \times 10^{-6})}{10^6}} = 1,73 \times 10^{-6}$$

The expanded uncertainty is  $\pm 1,96 \times 1,73 \times 10^{-6} = \pm 3,39 \times 10^{-6}$  at a 95 % confidence level.

The correct distribution  $p1(x_t)$  is the continuous function in figure 17.

NOTE: The true value is not BER, but number of bit errors, where BER= (bit errors/number of bits tested). The binomial function  $p(x_m)$  based on the true value = 3 bit errors (corresponding to BER =  $3 \times 10^{-6}$ ) is the discrete function shown.

The distribution  $p(x_t)$  (based on the binomial distribution with 3 bit errors and  $10^6$  bits tested):

$$p(x_t) = 100 \times k \times \left(\frac{x_t}{10^6}\right)^3 \times \left(1 - \frac{x_t}{10^6}\right)^{(10^6-3)} \quad \% \text{ where } k = \frac{10^6!}{3 \times (10^6-3)!} = 1,67 \times 10^{17}$$

The integral from  $-\infty$  to  $+\infty$  of  $p(x_t)$  is very close to 1. Therefore  $p(x_t)$  is a good approximation to the correct distribution  $p_1(x_t)$ .

By means of numerical methods the 95 % error limits are found to be +5,73 and -1,91 corresponding to  $+5,73 \times 10^{-6}$  and  $-1,91 \times 10^{-6}$ .

Figure 17 shows the discrete distribution giving the probabilities of measuring from 0 to 14 bit errors when the true value is 3 bit errors corresponding to  $\text{BER} = 3 \times 10^{-6}$ , and the continuous distribution giving the probability function for the true value when the measured value is 3 bit errors corresponding to  $\text{BER} = 3 \times 10^{-6}$ .

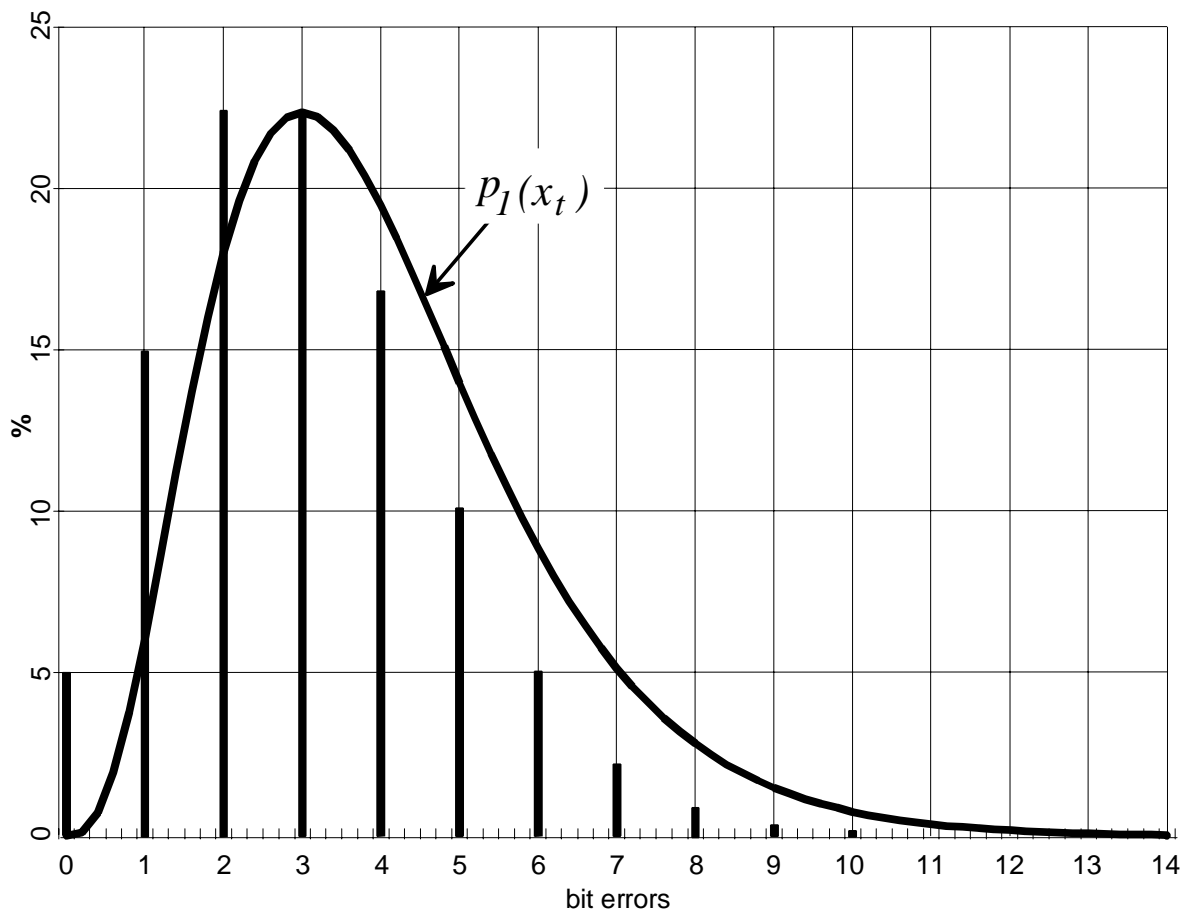

Figure 17: BER uncertainty

## 6.6.4 BER dependency functions

As in SINAD measurements, the BER of a receiver is a function of the signal to noise ratio of the RF signal at the input of the receiver.

Several modulation and demodulation techniques are used in data communication and the dependency functions are related to these techniques.

This clause covers the following types of modulation:

- coherent modulation/demodulation of the RF signal;
- non coherent modulation/demodulation of the RF signal;

- FM modulation.

The following assumes throughout that the data modulation uncertainty combines linearly to the carrier to noise ratio uncertainty. The uncertainty calculations are based on ideal receivers and demodulators where correctly matched filters are utilized.

The characteristics of practical implementations may differ from the theoretical models thereby having BER dependency functions which are different from the theoretical ones. The actual dependency functions can, of course, be estimated individually for each implementation. This, however, would mean additional measurements. Instead the theoretically deduced dependency functions may be used in uncertainty calculations.

#### 6.6.4.1 Coherent data communications

Coherent demodulation techniques are techniques which use absolute phase as part of the information. Therefore the receiver must be able to retrieve the absolute phase from the received signal. This involves very stable oscillators and sophisticated demodulation circuitry, but there is a gain in performance under noise conditions compared to non coherent data communication. Coherent demodulation is used, for example, in the GSM system with Gaussian Minimum Shift Keying (GMSK).

#### 6.6.4.2 Coherent data communications (direct modulation)

The BER as a function of  $SNR_b$ , the signal to noise ratio per bit for coherent binary systems is:

$$BER(SNR_b) = 0,5 \times erfc(\sqrt{SNR_b}) \quad (6.12)$$

where  $erfc(x)$  is defined as:

$$erfc(x) = \frac{2}{\sqrt{\pi}} \int_x^{\infty} e^{-t^2} dt \quad (6.13)$$

It is not possible to calculate the integral part of (6.11) analytically, but the BER as a function of the signal to noise ratio is shown in figure 18 together with the function for non coherent binary data communication.

There are different types of coherent modulation and the noise dependency of each varies, but the shape of the function remains the same. The slope, however, is easily calculated and, although it is negative, the sign has no meaning for the following uncertainty calculations:

$$\frac{d(BER)}{d(SNR_b)} = \frac{1}{2\sqrt{\pi \times SNR_b}} \times e^{-SNR_b} \quad (6.14)$$

For the purpose of calculating the measurement uncertainty, this can be approximated:

$$\frac{d(BER)}{d(SNR_b)} \approx 1,2 \times BER \quad (6.15)$$

If the aim is to transform BER uncertainty to level uncertainty - which is the most likely case in PMR measurements, the inverse dependency function must be used (the result is in percentage power terms as it is normalized by division with  $SNR_{b*}$ ):

$$u_{j \text{ level due to BER uncertainty}} = \left[ \frac{u_{jBER}}{\frac{d(BER)}{d(SNR_b)} \times SNR_{b*}} \right] 100\% \approx \frac{u_{jBER}}{1,2 \times BER \times SNR_{b*}} \times 100\% \quad (6.16)$$

The  $SNR_{b*}$  is a theoretical signal to noise ratio read from figure 19. It may not be the signal to noise ratio at the input of the receiver but the slope of the function is assumed to be correct for the BER measured.

For example: The sensitivity of a receiver is measured. The RF input level to the receiver is adjusted to obtain a BER of  $10^{-2}$ . The measured result is the RF level giving this BER. The BER is measured over a series of 25 000 bits. The resulting BER uncertainty is then calculated using formula (6.11):

$$u_{jBER} = \sqrt{\frac{0,01(1-0,01)}{25000}} = 6,29 \times 10^{-4}$$

The uncertainty of the RF signal at the input is 0,7 dB ( $u_j$ ). The signal to noise ratio giving this BER is then read from figure 18:  $SNR_b^*(0,01) = 2,7$  and the dependency function at this level is:

$$\frac{d(BER(2,7))}{d(SNR_b)} = 1,2 \times BER = 1,2 \times 10^{-2} = 1,2 \times 10^{-2}$$

The BER uncertainty is then transformed to level uncertainty using formula (6.16):

$$u_{jlevel} = \left[ \frac{6,29 \times 10^{-4}}{1,2 \times 10^{-2} \times 2,7} \right] \times 100\% = 1,95\% \text{ power} \approx \frac{1,95}{23,0} \text{ dB} = 0,085 \text{ dB}$$

$$u_{jRFlevel} = \sqrt{0,7^2 + 0,085^2 + \dots}$$

There is an additional uncertainty component due to resolution of the readout of the measured BER. If the RF input level has been adjusted to give a reading of 0,01 and the resolution of the BER meter is 0,001 the correct lies between 0,0095 and 0,0105 with equal probability.

The standard deviation is therefore

$$u_{jBERresolution} = \frac{0,5 \times 10^{-3}}{\sqrt{3}} = 2,89 \times 10^{-4}$$

This standard deviation is then by means of formula 6.16 converted to level uncertainty:

$$u_{jlevel due to BER resolution} = \frac{u_{jBERresolution}}{\frac{d(BER)}{d(SNR_b)} \times SNR_b} \times 100\%$$

$$u_{jlevel due to BER resolution} = \frac{0,289 \times 10^{-4}}{1,2 \times 0,01 \times 2,7} \times 100\% = 0,089\% \approx \frac{0,089}{23,0} \text{ dB} = 0,004 \text{ dB}$$

The total uncertainty of the sensitivity level is then:

$$u_{cRFlevel} = \sqrt{u_{jlevel}^2 + u_{jlevel due to BER resolution}^2 + u_j^2} = \sqrt{0,085^2 + 0,004^2 + 0,7^2} = 0,71 \text{ dB}$$

As can be seen the BER statistical uncertainty and the BER resolution only plays a minor role.

### 6.6.4.3 Coherent data communications (sub carrier modulation)

If a sub carrier frequency modulation is used in the data communication the functions related to direct coherent data communication apply, but in this case they give the relationship between BER and the signal to noise of the sub carrier. To be able to transform BER uncertainty to RF input level uncertainty the relationship between the sub carrier signal to noise ratio and the RF carrier signal to noise ratio must be calculated.

If the BER is measured at a RF level much higher than the sensitivity this relation is assumed to be 1:1 as described in clause 6.5.

In FM systems, if the BER is measured in the sensitivity region (below the knee point) the relationship as for analogue receivers is assumed and the same value taken from ETR 028 [15], part 2, annex F, table F.1,  $0,375 \text{ dB}_{RF \text{ i/p level}}/\text{dB}_{SINAD}$  and standard uncertainty  $0,075 \text{ dB}_{RF \text{ i/p level}}/\text{dB}_{SINAD}$ . (see clause 6.5).

**EXAMPLE:** The sensitivity of an FM receiver is measured. The RF input level to the receiver is adjusted to obtain a BER of  $10^{-2}$ . The measured result is the RF level giving this BER. The BER is measured over a series of 2 500 bits. The uncertainty of the RF signal at the input is 0,5 dB ( $u_j$ ).

The resulting BER uncertainty is then calculated using formula (6.11):

$$u_{j\text{BER}} = \sqrt{\frac{0,01(1-0,01)}{2500}} = 2,0 \times 10^{-3}$$

The signal to noise ratio giving this BER is then read from figure 18:  $\text{SNR}_b^*(0,01) = 2,7$ . The dependency function at this level is:

$$\frac{d(\text{BER}(2,7))}{d(\text{SNR}_b)} = 1,2 \times \text{BER} = 1,2 \times 1,0 \times 10^{-2} = 1,2 \times 10^{-2}$$

The BER uncertainty is then transformed to level (or  $\text{SNR}_b$ ) uncertainty using formula (6.4):

$$u_{j\text{SNR}_b} = \left[ \frac{2,0 \times 10^{-3}}{1,2 \times 10^{-2} \times 2,7} \right] \times 100 \% = 6,17 \% \text{ power, which is equal to } (6,17/23,0) = 0,27 \text{ dB.}$$

This uncertainty is then by means of formula (5.2) and the relationship taken from ETR 028 [15], part 2, annex F, table F.1 converted to RF input level uncertainty (as SINAD and  $\text{SNR}_b$  is considered to be equivalent in this case). The dependency function is: mean = 0,375 dB  $\text{RF i/p level/dB SINAD}$  and standard uncertainty 0,075 dB  $\text{RF i/p level/dB SINAD}$ .

$$u_{j\text{level}} = \sqrt{0,27^2 \times (0,38^2 + 0,08^2)} = 0,102 \text{ dB} \quad (\text{formula 5.2})$$

This RF level uncertainty is then combined with the uncertainty of the level of the input signal to obtain the total uncertainty of the sensitivity:

$$u_{j\text{sensitivity}} = \sqrt{0,5^2 + 0,10^2} = 0,51 \text{ dB}$$

In this example the uncertainty due to meter resolution is assumed to be negligible.

#### 6.6.4.4 Non coherent data communication

Non coherent modulation techniques disregard absolute phase information. Communications based on non coherent modulation tend to be more sensitive to noise, and the techniques used may be much simpler. A typical non coherent demodulation technique is used with FSK, where only the information of the frequency of the signal is required.

#### 6.6.4.5 Non coherent data communications (direct modulation)

The BER as a function of the  $\text{SNR}_b$  in this case is:

$$\text{BER}(\text{SNR}_b) = \frac{1}{2} e^{-\frac{\text{SNR}_b}{2}} \quad (6.17)$$

provided that the cross correlation coefficient  $c_{\text{cross}}$  between the two frequencies defining the zeros and the ones is 0. The cross correlation coefficient  $c_{\text{cross}}$  of two FSK signals with frequency separation  $f_\delta$  and the bit time  $T$  is:

$$|c_{\text{cross}}| = \left| \frac{\sin(\pi \times T \times f_\delta)}{\pi \times T \times f_\delta} \right| \quad (6.18)$$

It is assumed that the cross correlation coefficient for land mobile radio systems is so small that the formulas for  $c_{\text{cross}} = 0$  apply, and as  $c_{\text{cross}}$  is 0 the BER, as a function of the  $\text{SNR}_b$  for non coherent modulation is shown in equation 6.15.

The slope of the function (in fact the slope is negative, but the sign is of no interest for the uncertainty calculation). The BER ( $SNR_b$ ) function for non coherent data communication is shown in figure 19.

The inverse function is:

$$SNR_b(BER) = -2 \times \ln(2 \times BER) \quad (6.19)$$

From (6.17) the slope of  $SNR_b(BER)$  is:

$$\frac{d(SNR_b)}{d(BER)} = -\frac{2}{BER} \quad (6.20)$$

The slope of the function is the inverse of (6.18):

$$\frac{d(BER)}{d(SNR_b)} = \frac{BER}{2} \quad (6.21)$$

The  $SNR_b$  can be calculated by means of formula (6.19) or read from the function shown in figure 19. If the aim is to transform BER uncertainty to level uncertainty - which is generally the case in PMR measurements - formula (6.16) is used.

$$u_{j\ level} = \frac{u_{j\ BER}}{\frac{d(BER)}{d(SNR_b)} \times SNR_b^*}$$

Before it can be combined with the other part uncertainties at the input of the receiver it must be transformed to linear voltage terms.

**EXAMPLE:** The sensitivity of a receiver is measured. The RF input level to the receiver is adjusted to obtain a BER of  $10^{-2}$ . The measured result is the RF level giving this BER. The BER is measured over a series of 2 500 bits. The uncertainty of the RF signal at the input is 0,6 dB ( $u_j$ ).

The resulting BER uncertainty is then calculated using formula (6.11):

$$u_{j\ BER} = \sqrt{\frac{0,01 \times 0,99}{2500}} = 2,00 \times 10^{-3}$$

The signal to noise ratio giving this BER is then calculated using formula (6.19).

$$SNR_b(0,01) = -2 \times \ln(2 \times 0,01) = 7,824$$

The dependency function at this level is (formula (6.21)):

$$\frac{d(BER(7,824))}{d(SNR_b)} = 0,5 \times 0,01$$

The BER uncertainty is then transformed to level uncertainty using formula (6.16):

$$u_{j\ level} = \left[ \frac{2,00 \times 10^{-3}}{0,5 \times 10^{-2} \times 7,824} \right] \times 100 \% = 5,11 \% \text{ power}$$

which is equal to  $5,11/23,0 \text{ dB} = 0,22 \text{ dB}$  ( $u_j$ ) in voltage terms. This RF level uncertainty is then combined with the rest of the uncertainty contribution to give the combined standard uncertainty of the RF level.

$$u_{c\ RF\ level} = \sqrt{(0,6)^2 + (0,22)^2} = 0,64 \text{ dB}$$

### 6.6.4.6 Non coherent data communications (sub carrier modulation)

If a sub carrier modulation is used in the data communication the functions related to direct non coherent data communications apply, but in this case they give the relation between BER and signal to noise ratio of the sub carrier. To be able to transform BER uncertainty to RF input level uncertainty the relationship between the sub carrier signal to noise ratio and the RF carrier signal to noise ratio must be calculated. If the BER is measured at a RF level much higher than the sensitivity this relationship is assumed to be 1:1 as described in clause 6.5.

In FM systems, If the BER is measured in the sensitivity region (below the knee point) the relationship as for analogue receivers is assumed and the same value taken from ETR 028 [15], part 2, annex F, table F.1,  $0,375 \text{ dB}_{RF \text{ level}}/\text{dB}_{SINAD}$  and standard uncertainty  $0,075 \text{ dB}_{RF \text{ level}}/\text{dB}_{SINAD}$  (see clause 6.5).

**EXAMPLE:** The sensitivity of an FM receiver is measured. The RF input level to the receiver is adjusted to obtain a BER of  $10^{-2}$ . The measured result is the RF level giving this BER. The BER is measured over a series of 2 500 bits. The uncertainty of the RF signal at the input is 0,6 dB ( $u_j$ ). The resulting BER uncertainty is then calculated using formula (6.11):

$$u_{jBER} = \sqrt{\frac{0,01 \times 0,99}{2500}} = 2,00 \times 10^{-3}$$

The signal to noise ratio giving this BER is then calculated using formula (6.19).

$$SNR_b^*(0,01) = -2 \times \ln(2 \times 0,01) = 7,824$$

The dependency function at this level is:

$$\frac{d(BER(7,824))}{d(SNR_b)} = \frac{0,01}{2}$$

This BER uncertainty is then transformed to level uncertainty using formula (6.16):

$$u_{j \text{ level}} = \left[ \frac{2,00 \times 10^{-3}}{0,5 \times 10^{-2} \times 7,824} \right] \times 100 \% = 5,11 \% \text{ power}$$

which is equal to  $5,11/23,0 = 0,22 \text{ dB}$  ( $u_{j \text{ level}}$ ). This sub carrier level uncertainty is then transformed to RF level uncertainty.

$$u_{j \text{ RF level transformed}} = \sqrt{(0,22)^2 \times \left( \frac{0,375 \text{ dB}_{RF \text{ level}}/\text{dB}_{SINAD}}{1} \right)^2 + (0,075 \text{ dB}_{RF \text{ level}}/\text{dB}_{SINAD})^2} = 0,08 \text{ dB}$$

**NOTE:** As the uncertainty is small the dependency function can be used directly without transforming to dB.

This RF level uncertainty is then combined with the uncertainty of the level of the input signal to obtain the total uncertainty of the sensitivity:

$$u_{j \text{ sensitivity}} = \sqrt{(0,6)^2 + (0,08)^2} = 0,61 \text{ dB}$$

The uncertainty due to meter resolution is assumed to be negligible.

### 6.6.5 Effect of BER on the RF level uncertainty

The  $SNR_b$  to BER function is used to transform BER uncertainty to RF input level uncertainty. In the measurements on PMR equipment the RF input level is adjusted to obtain a specified BER. A sufficiently large number of bits are examined to measure the BER, but still there is a (small) measurement uncertainty contribution  $u_{j \text{ BER}}$ .

### 6.6.5.1 BER at a specified RF level

If the purpose is to measure the BER at a specific input level, the transformation is more of a problem. The BER function is so non-linear that the approximation where  $(dBER)/(dSNR_p)$  is used as the dependency function is no longer sufficient.

One approach is to calculate the uncertainty limits of the RF input level at the wanted confidence level, and then apply these limits directly to the BER function. In this case the statistical uncertainty in the BER measurement is ignored, but as the following example shows, the uncertainty due to this is negligible.

For example: The BER of a receiver is measured with the RF input level adjusted to the sensitivity limit. A BER of  $0,75 \times 10^{-2}$  is measured over a series of 25 000 bits. The uncertainty of the RF signal at the input is 1,1 dB ( $u_j$ ). The resulting BER uncertainty is then calculated using formula (6.11):

$$u_{j\text{ BER}} = \sqrt{\frac{0,0075(1-0,0075)}{25000}} = 5,45 \times 10^{-4} \text{ corresponding to } 7,3 \%$$

The straight forward procedure of calculating the combined standard uncertainty by applying a 1<sup>st</sup> order dependency function to the standard uncertainty of the RF input level uncertainty does not reflect reality due to the non linearity of the BER function. This is shown in the following calculation.

The dependency function is  $1,2 \times 0,75 \times 10^{-2} = 0,9 \times 10^{-2}$  found by formula 6.3. The  $SNR_p$  at BER= 0,0075 is read to be 2,9 from figure 21. The level uncertainty of 1,1 dB corresponds to  $1,1 \times 23,0 \%$  ( $p$ ) = 25,5 % ( $u_j$ ). This is transformed to  $SNR_p$  uncertainty:  $0,255 \times 2,9 = 0,74$  ( $u_j$ ). The level uncertainty is then transformed to BER uncertainty by means of the dependency function.

$$u_{j\text{ BER}} = 0,74 \times 0,9 \times 10^{-2} = 0,666 \times 10^{-2}.$$

The expanded uncertainty =  $\pm 1,96 \times 0,666 \times 10^{-2} = \pm 1,31 \times 10^{-2}$  at a 95 % confidence level. This expanded uncertainty would give a **negative** bit error ratio as the lower limit. The reason is the non-linearity of the BER function (see also the discussion on confidence levels and their relations with the actual distributions, in clause D.5.6.2 of part 2).

Therefore another method should be applied.

The expanded uncertainty should be expressed at a 95 % confidence level. Therefore the input level uncertainty limits are found to be  $\pm 1,96 \times 1,1 \text{ dB} = \pm 2,16 \text{ dB}$ . This corresponds to 1,64 and 0,608 (power values). The values corresponding to the 95 % confidence level is then  $2,9 \times 1,64 = 4,76$  and  $2,9 \times 0,608 = 1,76$ .

By means of figure 18 the BER uncertainty limits at 95 % confidence level are read to be  $3,0 \times 10^{-2}$  and  $1,0 \times 10^{-3}$  corresponding to +300 % and -87 %.



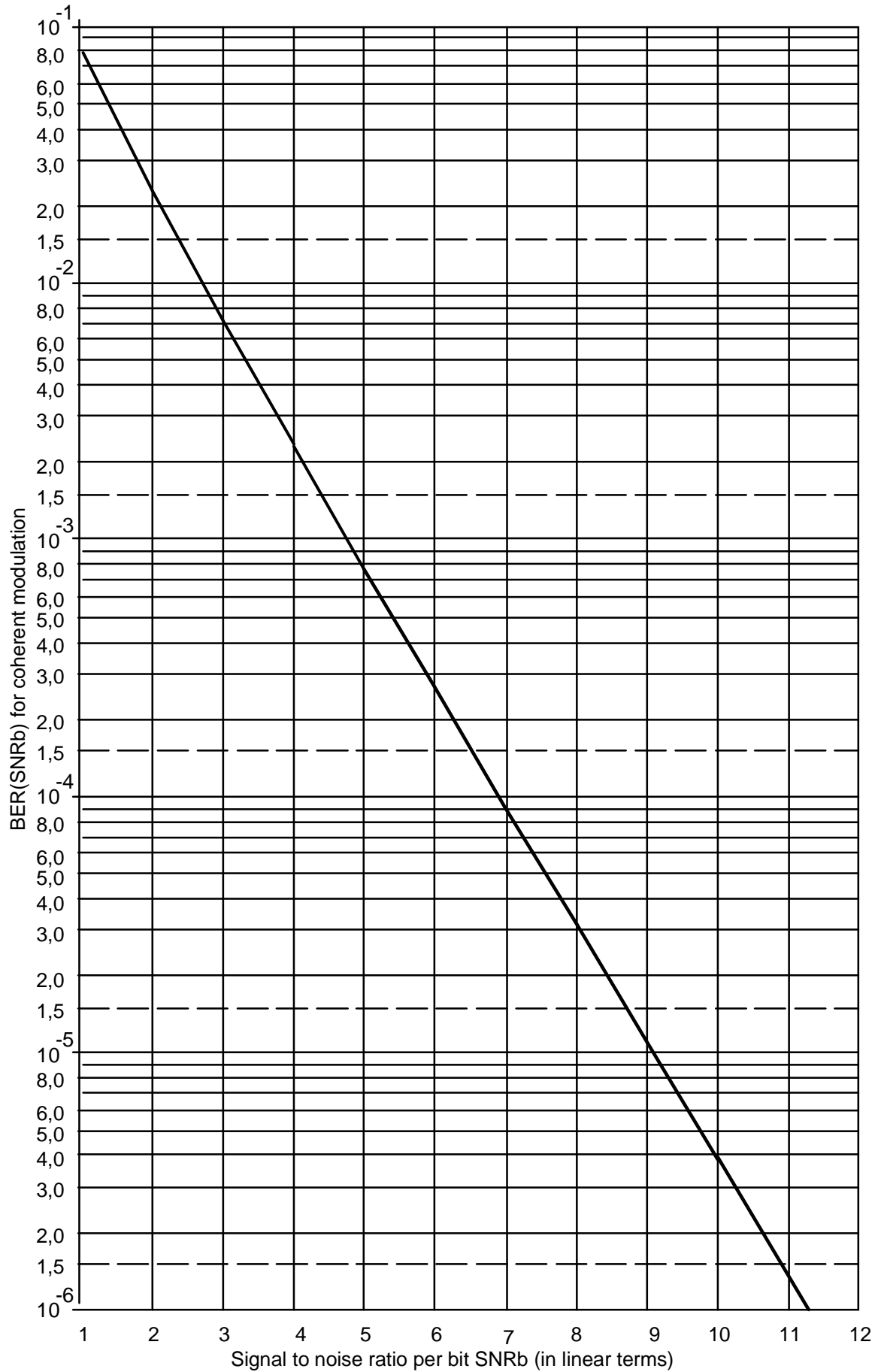

Figure 18: BER ( $SNR_b$ ) against  $SNR_b$

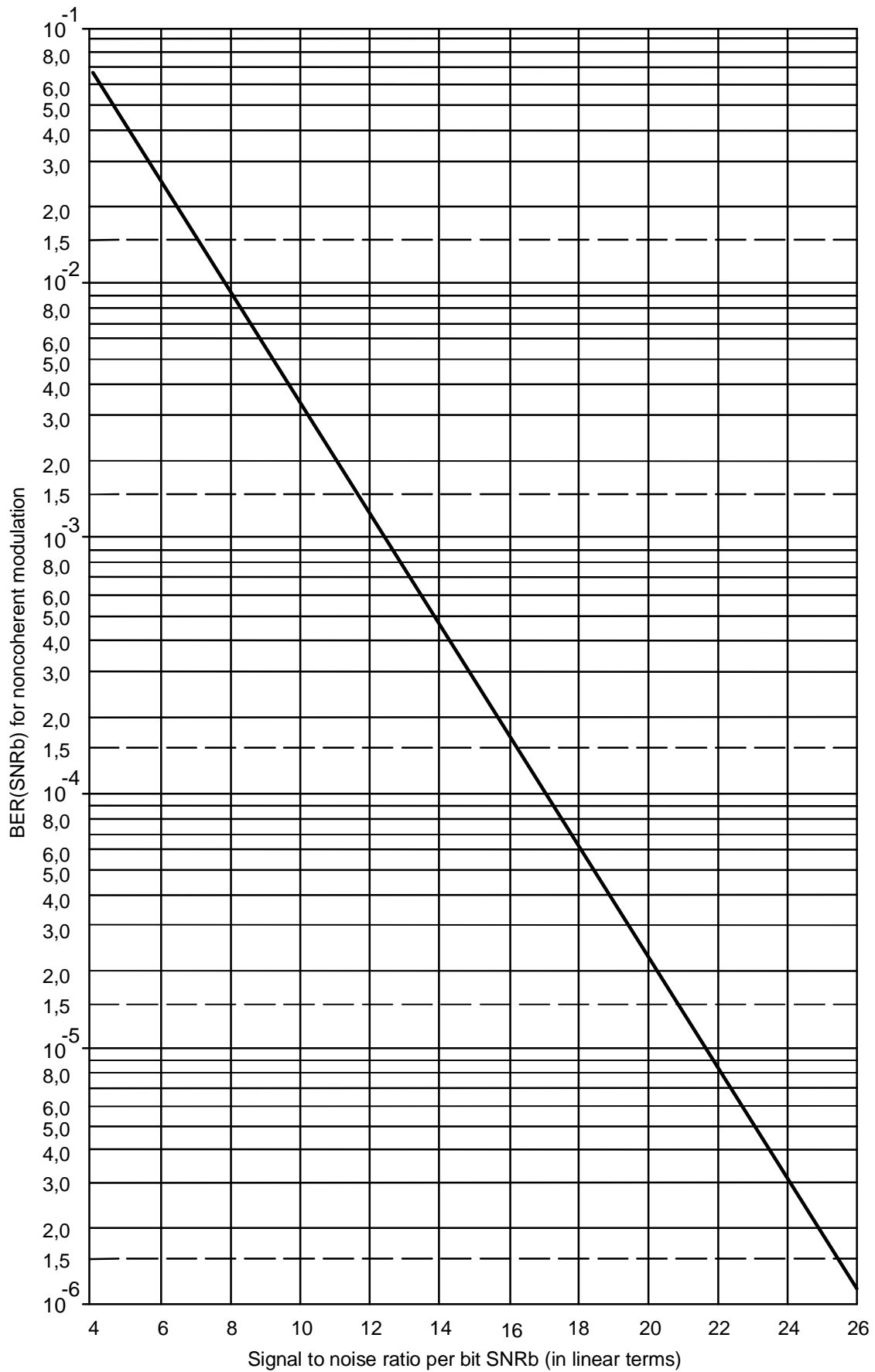

Figure 19: BER (SNR<sub>b</sub>) against SNR<sub>b</sub>

## 6.7 Uncertainty in measuring messages

### 6.7.1 General

If the EUT is equipped with message facilities the characteristic used to assess the performance of the equipment is the Message acceptance ratio. The Message acceptance ratio is the ratio of the number of Messages accepted to the total number of message sent.

Normally it is required to assess the receiver performance at a Message acceptance ratio of 80 %. The Message acceptance ratio is used as a measure of receiver performance in digital radio systems in a similar way that SINAD and BER ratios are used as a measure of receiver performance in analogue and bit stream measurements, particularly in sensitivity and immunity measurements.

### 6.7.2 Statistics involved in the measurement

When considering messages, parameters such as message length (in bits), type of modulation (direct or sub-carrier, coherent or non-coherent), affect the statistics that describe the behaviour of the receiver system.

Performance of the receiver is assessed against a message acceptance ratio set by the appropriate standard and/or methodology used. To assess the uncertainty the cumulative probability distribution curves for message acceptance are required, these can be calculated from (6.20).

$$Pe_{(0)} + Pe_{(1)} + Pe_{(2)} + Pe_{(3)} + \dots + Pe_{(n)} \quad (6.22)$$

Where: n is the message length:

- $Pe_{(0)}$  is the probability of 0 errors;
- $Pe_{(1)}$  is the probability of 1 errors;
- $Pe_{(2)}$  is the probability of 2 errors;
- $Pe_{(3)}$  is the probability of 3 errors;
- $Pe_{(n)}$  is the probability of n errors.

The individual contribution of each probability  $Pe_{(x)}$  in formula (6.22) is calculated using formula (6.8). Curves for a theoretical 50 bit system with 1, 2, 3, 4, 5 and 6 bits of error correction are shown in figure 20.

As the number of bits of error correction increase so does the slope of the relevant portion of the cumulative probability density function, and as the slope increases less carrier to noise (or RF input level) variation is required to cause the message acceptance ratio to vary between 0 % and 100 %.

This effect is increased in non-linear systems by a factor of approximately 3:1. Due to the increased slope associated with sub-carrier modulation, as a result of this in our theoretical 50 bit system, 6 bits of error correction will result in a very well defined level of 0 % acceptance to 100 % acceptance, (with 1 dB level variation), however, with no error correction, the level variation between 0 % and 100 % acceptance will be several dB.

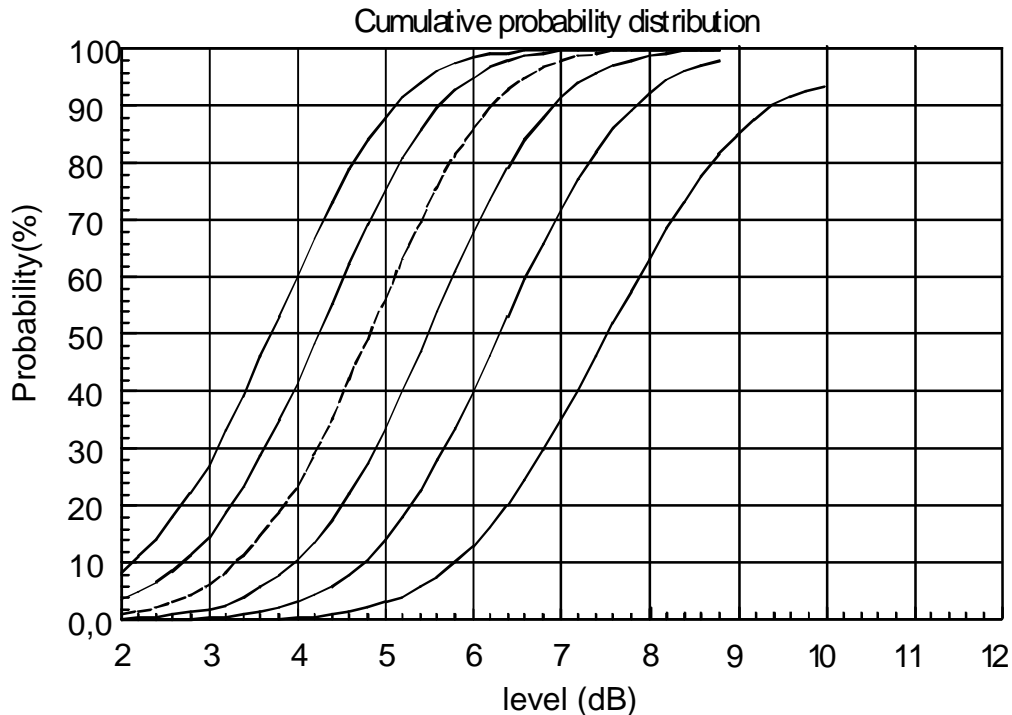

**Figure 20: Cumulative Probability (error correction for Messages)**

As a method of testing receivers the "up-down" method is used. The usage of the up down method will result in a series of transmissions using a limited number of RF levels.

### 6.7.3 Analysis of the situation where the up down method results in a shift between two levels

With some systems (e.g. 6 bits of error correction) the up-down method will typically result in a pattern shifting between two levels, where at the lower level the message acceptance ratio will approach zero and at the higher level (+1 dB) the message acceptance ratio will approach 100 %. In this case the measurement uncertainty is of the simplest form for this contribution.

The RF is switching between two levels, the mean value is calculated, usually from 10 or 11 measurements. The measurement uncertainty cannot be calculated as though random, independent sources are involved. The RF is switching between two output levels of the same signal generator, the levels therefore are correlated and only have two values (upper and lower), hence the standard uncertainty for a signal generator with output level uncertainty of  $\pm 1$  dB is:

$$u_{j \text{ output level}} = \frac{1,0}{\sqrt{3}} = 0,58 \text{ dB}$$

Also there is a quantization uncertainty associated with half of the step size (in this case 1 dB which gives  $\pm 0,5$  dB).

$$u_{j \text{ quantisation}} = \frac{0,5}{\sqrt{3}} = 0,29 \text{ dB}$$

Therefore the combined standard uncertainty of this step will be:

$$u_{ctwolevelshift} = \sqrt{u_{j \text{ output level}}^2 + u_{j \text{ quantisation}}^2} = \sqrt{0,58^2 + 0,29^2} = 0,65 \text{ dB}$$

For the case of no error correction the pattern of the measured results will spread beyond a single dB step and measurement uncertainty calculations are more complex.

## 6.7.4 Detailed example of uncertainty in measuring messages

For this example a theoretical system with 50 bit message length and 1 bit error correction will be considered, although the principles can be applied to all practicable message and correction lengths.

- a) Calculate the message acceptance ratio (formula (6.22)) for the given message length and given number of bit error corrections, using bit error ratios corresponding to a convenient step size (in this case 1 dB) using either formula (6.18) for non-coherent, or, formula (6.12) for coherent, and if sub-carrier modulation is used, use the appropriate SINAD conversion in ETR 028 [15], part 2, annex F, table F.1.
- b) Now the probability of being at a given point on the curve must be assessed. For example the probability of being at a particular point (in figure 20) is:
  - the probability of being below a particular point times the probability of going up from this point; plus
  - the probability of being above a particular point times the probability of going down from this point.

The method requires three successful responses, therefore the probability of going up is:

$$Pp_{(up)} = 1 - (\text{Message Acceptance})^3 = 1 - (MA)^3 \quad (6.23)$$

and the probability of going down is:

$$Pp_{(down)} = (\text{Message Acceptance})^3 = (MA)^3 \quad (6.24)$$

$(Pe_{(0)} + Pe_{(1)})$  = Probability of 0 errors + the probability of 1 error (see formula (6.24)). These calculations are shown in table 2.

**Table 2: Probability of going up or down from a given position**

dB	Linear	BER	$(Pe_{(0)}+Pe_{(1)})\%$	$Pp_{(up)}=1-(MA)^3$	$Pp_{(down)}=(MA)^3$
+2	12,679	$0,8826 \times 10^{-3}$	99,91	$2,698 \times 10^{-3}$	$997,3 \times 10^{-3}$
+1	10,071	$3,251 \times 10^{-3}$	98,83	$34,69 \times 10^{-3}$	$965,3 \times 10^{-3}$
0	8,000	$9,158 \times 10^{-3}$	92,30	$213,7 \times 10^{-3}$	$786,3 \times 10^{-3}$
-1	6,355	$20,84 \times 10^{-3}$	72,02	$626,4 \times 10^{-3}$	$373,6 \times 10^{-3}$
-2	5,048	$40,07 \times 10^{-3}$	39,95	$936,2 \times 10^{-3}$	$63,76 \times 10^{-3}$
-3	4,010	$67,33 \times 10^{-3}$	14,13	$997,2 \times 10^{-3}$	$2,821 \times 10^{-3}$
-4	3,185	$101,7 \times 10^{-3}$	3,123	1,000	$30,46 \times 10^{-6}$
-5	2,530	$141,1 \times 10^{-3}$	0,459	1,000	$96,55 \times 10^{-9}$

Based on equations (6.21) and (6.22), and the fact that the sum of all probabilities equals 1, the individual probabilities of being at each step of the signal to noise ratio per bit ( $SNR_b$ ) can be calculated.

Assuming that at  $SNR_b$  greater than +1 dB all messages are accepted (therefore can only move down from here) and Assuming that at  $SNR_b$  less than -4 dB all messages are rejected (therefore can only move up from here), this gives rise to two boundary positions -5 dB and +2 dB.

The probability of being at any one of the points -5, -4, -3, -2, -1, 0, +1, +2 is  $Pp_{-5}$ ,  $Pp_{-4}$ ,  $Pp_{-3}$ ,  $Pp_{-2}$ ,  $Pp_{-1}$ ,  $Pp_0$ ,  $Pp_{+1}$ , and  $Pp_{+2}$  respectively.

The analysis of the possible transitions between these points provide:

- $Pp_{-5} = (Pp_{-4} + 30,46 \times 10^{-6}) + (Pp_{-6} \times 1)$ ;
- $Pp_{-4} = (Pp_{-3} \times 2,821 \times 10^{-3}) + (Pp_{-5} \times 1)$ ;
- $Pp_{-3} = (Pp_{-2} \times 63,76 \times 10^{-3}) + (Pp_{-4} \times 1)$ ;
- $Pp_{-2} = (Pp_{-1} \times 373,6 \times 10^{-3}) + (Pp_{-3} \times 997,2 \times 10^{-3})$ ;

- $P_{p,-1} = (P_{p,0} \times 786,3 \times 10^{-3}) + (P_{p,-2} \times 936,2 \times 10^{-3})$ ;
- $P_{p,0} = (P_{p,+1} \times 965,3 \times 10^{-3}) + (P_{p,-1} \times 626,4 \times 10^{-3})$ ;
- $P_{p,+1} = (P_{p,+2} \times 1) + (P_{p,0} \times 213,7 \times 10^{-3})$ ;
- $P_{p,+2} = (P_{p,+3} \times 1) + (P_{p,+1} \times 34,69 \times 10^{-3})$ .

NOTE: The probability of being at point  $P_{p,-6}$  or  $P_{p,+3}$  is zero, hence  $P_{p,-6} \times 1$  and  $P_{p,+3} \times 1$  are both equal to zero.

Based on seven out of these eight equations and the fact that the sum of  $P_{p,-5}$  to  $P_{p,+2}$  is one, each individual probability  $P_{p,-5}$  to  $P_{p,+2}$  is calculated as follows.

Rearranging the above equations gives:

- $P_{p,-6} \times 1 - P_{p,-5} + P_{p,-4} \times 30,46 \times 10^{-6} = 0$ ;
- $P_{p,-5} \times 1 - P_{p,-4} + P_{p,-3} \times 2,821 \times 10^{-3} = 0$ ;
- $P_{p,-4} \times 1 - P_{p,-3} + P_{p,-2} \times 63,76 \times 10^{-3} = 0$ ;
- $P_{p,-3} \times 997,3 \times 10^{-3} - P_{p,-2} + P_{p,-1} \times 373,6 \times 10^{-3} = 0$ ;
- $P_{p,-2} \times 936,2 \times 10^{-3} - P_{p,-1} + P_{p,0} \times 786,3 \times 10^{-3} = 0$ ;
- $P_{p,-1} \times 626,4 \times 10^{-3} - P_{p,0} + P_{p,+1} \times 965,3 \times 10^{-3} = 0$ ;
- $P_{p,0} \times 213,7 \times 10^{-3} - P_{p,+1} + P_{p,+2} \times 1 = 0$ ;
- $P_{p,+1} \times 34,69 \times 10^{-3} - P_{p,+2} + P_{p,+3} \times 1 = 0$ ;
- $P_{p,-5} + P_{p,-4} + P_{p,-3} + P_{p,-2} + P_{p,-1} + P_{p,0} + P_{p,+1} + P_{p,+2} = 1$ ;
- $P_{p,-6} = P_{p,+3} = 0$ .

	$P_{p,-5}$	$P_{p,-4}$	$P_{p,-3}$	$P_{p,-2}$	$P_{p,-1}$	$P_{p,0}$	$P_{p,+1}$	$P_{p,+2}$	
1	1	-1	$2,821 \times 10^{-3}$						
2		1	-1	$63,76 \times 10^{-3}$					
3			$997,3 \times 10^{-3}$	-1	$373,6 \times 10^{-3}$				
4				$936,2 \times 10^{-3}$	-1	$786,3 \times 10^{-3}$			
5					$626,4 \times 10^{-3}$	-1	$965,3 \times 10^{-3}$		
6						$213,7 \times 10^{-3}$	-1	1	
7							$34,69 \times 10^{-3}$	-1	
8	1	1	1	1	1	1	1	1	1

Solving this by means of row operations on row 8, gives:

1	1	-1	$2,821 \times 10^{-3}$						
2		1	-1	$63,76 \times 10^{-3}$					
3			$997,3 \times 10^{-3}$	-1	$373,6 \times 10^{-3}$				
4				$936,2 \times 10^{-3}$	-1	$786,3 \times 10^{-3}$			
5					$626,4 \times 10^{-3}$	-1	$965,3 \times 10^{-3}$		
6						$213,7 \times 10^{-3}$	-1	1	
7							$34,69 \times 10^{-3}$	-1	
8								392,91	1

From this we have:  $392,91 \times Pp_{+2} = 1$ ; therefore  $Pp_{+2} = 2,545 \times 10^{-3}$ :

- this is then used in row 7 to determine  $Pp_{+1}$ :  $Pp_{+1} = \frac{2,545 \times 10^{-3}}{34,69 \times 10^{-3}} = 73,36 \times 10^{-3}$ ;
- this is used in row 6 to determine  $Pp_0$ :  $Pp_0 = \frac{0,07336 - (2,545 \times 10^{-3} \times 1)}{213,7 \times 10^{-3}} = 331,38 \times 10^{-3}$ ;
- this is used in row 5 to determine  $Pp_{-1}$ :  $Pp_{-1} = \frac{331,38 \times 10^{-3} - (73,36 \times 10^{-3} \times 965,3 \times 10^{-3})}{626,4 \times 10^{-3}} = 415,97 \times 10^{-3}$ ;
- this is used in row 4 to determine  $Pp_{-2}$ :  $Pp_{-2} = \frac{415,97 \times 10^{-3} - (0,33138 \times 0,7863)}{0,9362} = 166,0 \times 10^{-3}$ ;
- this is used in row 3 to determine  $Pp_{-3}$ :  $Pp_{-3} = \frac{166,00 \times 10^{-3} - (0,41597 \times 0,3736)}{0,9973} = 10,622 \times 10^{-3}$ ;
- this is used in row 2 to determine  $Pp_{-4}$ :  $Pp_{-4} = \frac{10,622 \times 10^{-3} - (0,1660 \times 63,76 \times 10^{-3})}{1} = 37,84 \times 10^{-6}$ ;
- this is used in row 1 to determine  $Pp_{-5}$ :  $Pp_{-5} = \frac{37,84 \times 10^{-6} - (10,622 \times 10^{-3} \times 2,821 \times 10^{-3})}{1} = 7,87 \times 10^{-6}$ .

There are, off course, other ways of solving the equations.

After having calculated the probabilities it should always be checked that the sum of all probabilities is 1. If the sum is not 1 (to within 0,001) it can cause major uncertainties in the calculation of the resulting standard uncertainty of the distribution.

Based on these probabilities the standard uncertainty of the distribution is calculated:

$$X = \sum_{i=-5}^{i=2} Pp_i \times i = -0,70 \quad (\text{formula 5.6})$$

$$Y = \sum_{i=-5}^{i=2} Pp_i \times i^2 = 1,26 \quad (\text{formula 5.7})$$

then:

$$u_j = \sqrt{Y - X^2} = \sqrt{1,26 - (-0,70)^2} = 0,88 \text{ dB} \quad (\text{formula 5.8})$$

and the standard uncertainty for the measurement (as the result is the average value of 10 samples):

$$\frac{0,88}{\sqrt{10}} = 0,28 \text{ dB} \quad (\text{formula 5.9})$$

The expanded uncertainty is  $\pm 1,96 \times 0,28 = \pm 0,54$  dB at a 95 % confidence level.

Therefore the methodology introduces an additional  $\pm 0,54$  dB of uncertainty to the level.

## 6.8 Examples of measurement uncertainty analysis (Free Field Test Sites)

### 6.8.1 Introduction

This clause contains detailed worked examples of the calculation of expanded uncertainty of the radiated tests on Free Field Test Sites i.e. Anechoic Chambers, Anechoic Chamber with a ground plane and Open Area Test Sites.

The example tests given are limited to:

- a verification procedure;
- the measurement of a transmitter parameter (spurious emission);
- the measurement of a receiver parameter (sensitivity).

All the example tests are assumed to have been carried out in an Anechoic Chamber with a ground plane since this type of test site will contribute virtually all the uncertainty contributions involved in radiated tests on any Free Field Test Site (i.e. all uncertainties associated with absorbing materials and ground planes).

NOTE 1: The values given to the uncertainty components in these examples are only to illustrate the uncertainty calculations. In practice, values should be derived by consulting annex A.

All radiated tests consist of two stages. For a verification procedure, the first stage is to set a reference level whilst the second stage involves the measurement of path loss between two antennas. For the measurement of a particular parameter from an EUT, the first stage is usually to measure the relevant parameter whilst the second stage compares this measurement against that from a known standard.

Within any radiated test there are uncertainty components that are common to both stages of the test. By their different natures some of these common uncertainties will cancel (e.g. the uncertainty of the insertion loss of a cable common to both parts) whilst others may contribute twice (e.g. the level stability of a signal generator in receiver tests). In each of the following uncertainty analyses, uncertainty components common to both stages are shown as shaded areas in the accompanying schematic diagrams.

As shown in the examples, all the individual uncertainty components for any test are combined in the manner described in ETR 273 [12], part 1, subpart 1, clauses 4 and 5 in order to derive an expanded uncertainty figure for the measurement. The values of the individual components are either provided in annex A or should be taken from manufacturers' data sheets. Whenever they are obtained from data sheets, worst case figures given over a frequency band should be used. For example, in the case of a signal generator whose absolute level accuracy is quoted as  $\pm 1$  dB over 30 MHz to 300 MHz,  $\pm 2$  dB over 300 MHz to 1 000 MHz the figure for the band containing the test frequency should be used. This approach should be adopted for all uncertainty components, taking the uncertainty figures over as broad a band as possible. This is normally satisfactory when the variation with frequency is not large and provides a simple and flexible approach. The resulting expanded uncertainty figure is valid across a broad range of frequencies and measurement conditions and avoids the necessity of repeated calculation for minor frequency changes.

NOTE 2: Taking specific frequency values may result in a lower expanded uncertainty value, but this lower value is only valid when that specific set of circumstances apply for which the value was derived.

### 6.8.2 Example 1: Verification procedure

The verification procedure is a process carried out to prove a facility's suitability as a Free Field Test Site. It involves the transmission of a known signal level from one calibrated antenna (usually a dipole) and the measurement of the received signal level in a second calibrated antenna (also usually a dipole). By comparison of the transmitted and received signal levels, an "insertion loss" can be deduced.

For the measurement of NSA two stages are involved. The first is a direct attenuation measurement ( $V_{direct}$ ) whilst the second is a radiated attenuation measurement ( $V_{site}$ ). After inclusion of any correction factors relevant to the measurement, the figure of loss which results from the verification procedure is known as "Site Attenuation".

NSA is determined from the value of Site Attenuation by subtraction of the antenna factors and mutual coupling effects. The subtraction of the antenna factors and any mutual coupling effects makes NSA independent of antenna type.



Symbolically:

$$NSA = V_{direct} - V_{site} - AF_T - AF_R - AF_{TOT}$$

where:  $V_{direct}$  = received voltage using the "in-line" adapter;

$V_{site}$  = received voltage using the antennas;

$AF_T$  = antenna factor of the transmitting antenna;

$AF_R$  = antenna factor of the receiving antenna;

$AF_{TOT}$  = mutual coupling correction factor.

The verification procedure measures both  $V_{direct}$  and  $V_{site}$  and then (after relevant corrections and calculations) compares the measured value of NSA against the theoretical figure calculated for that particular type of facility. The difference between the two values at any specific frequency is a measure of the quality of the facility at that frequency.

### 6.8.2.1 Uncertainty contributions: Stage 1: Direct attenuation measurement

The first stage of the verification procedure is the direct attenuation measurement. This is carried out with all the items of test equipment connected directly together via an "in line" adapter between the attenuators as shown in figure 21. The components shown shaded are common to both stages of the procedure.

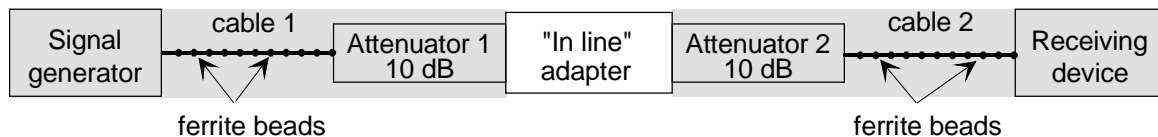

**Figure 21: Stage 1: Direct attenuation measurement**

Despite the commonality of most of the components to both stages of this procedure, the mismatch uncertainty contribution for both stages has to be calculated and included in the uncertainty calculations. This is a result of load conditions varying (i.e. antennas replacing the adapter in the second stage). Conversely, as a result of this commonality, the uncertainty contributions of some of the individual components will cancel.

Whereas figure 21 shows, schematically, the test equipment set-up for this stage of the verification procedure, an analysis diagram of the individual components (each of which contributes its own uncertainty) for this stage of the measurement is shown in figure 22. Again, as stated above, the shaded areas represent components common to both stages of the verification procedure.

#### 6.8.2.1.1 Contributions from the mismatch components

**Mismatch: direct attenuation measurement:** The value of the combined standard uncertainty of the contribution due to the mismatch from the source to the receptor, i.e. between the signal generator and the receiving device, is calculated from the approach described in annex G. All the individual contributions are U-distributed.

NOTE 1: In this example the value taken for the signal generator output reflection coefficient is the worst case value over the frequency band of interest. Similarly for the cable, adapter and attenuator VSWRs.

NOTE 2: The attenuation values of the cables and attenuators should be obtained from the data sheets/calibration records at the specific frequency of the test, along with the associated uncertainties for these values.

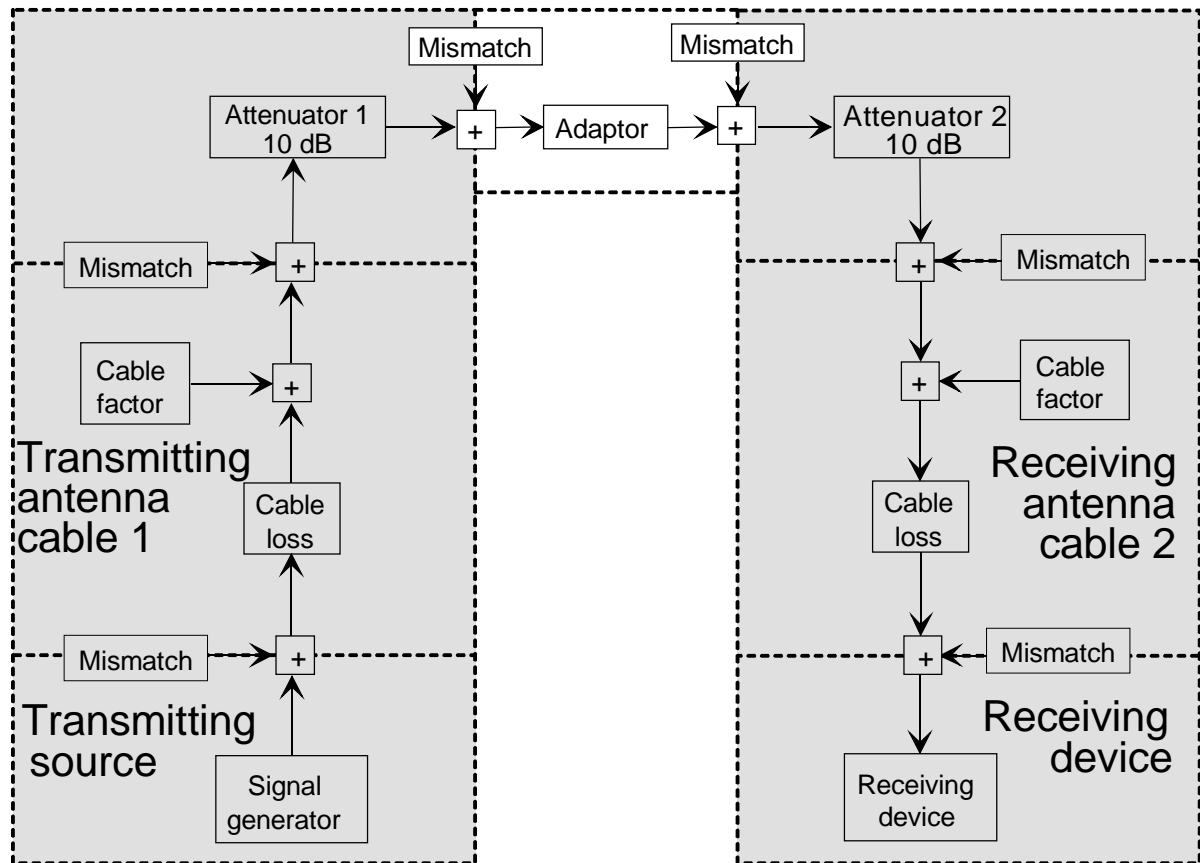

Figure 22: Stage 1: Direct attenuation measurement individual uncertainty components

Signal generator:	Output reflection coefficient: $ \rho_G $	= 0,20
Cable:	Input and output reflection coefficients: $ S_{11}  =  S_{22} $	= 0,07
	Attenuation: 1 dB = $ S_{12}  =  S_{21} $	= 0,891
Attenuator:	Input and output reflection coefficients $ S_{11}  =  S_{22} $	= 0,05
	Attenuation = 10 dB $ S_{12}  =  S_{21} $	= 0,3162
Adapter:	Input and output reflection coefficients $ S_{11}  =  S_{22} $	= 0,02
	Attenuation = 0,1 dB $ S_{12}  =  S_{21} $	= 0,9886
Attenuator:	Input and output reflection coefficients $ S_{11}  =  S_{22} $	= 0,05
	Attenuation = 10 dB $ S_{12}  =  S_{21} $	= 0,3162
Cable:	Input and output reflection coefficients: $ S_{11}  =  S_{22} $	= 0,07
	Attenuation: 1 dB = $ S_{12}  =  S_{21} $	= 0,891
Receiving device:	Input reflection coefficient: $ \rho_{RD} $	= 0,20

**Mismatch uncertainty in the direct attenuation measurement:** In the following the transmitting antenna cable is named cable 1, the transmitting antenna attenuator is named attenuator 1, the receiving antenna cable is named cable 2, the receiving attenuator is named attenuator 2. Those components that are constant for both stages 1 and 2 are not calculated as they do not contribute to the overall uncertainty.

Mismatch between:

- $u_{j \text{ generator and cable 1}}$ : Constant for both stage 1 and 2. Hence this value does not contribute.
- $u_{j \text{ cable 1 and attenuator 1}}$ : Constant for both stage 1 and 2. Hence this value does not contribute.

$$u_{j \text{ mismatch:attenuator1and adapter}} = \frac{0,05 \times 0,02 \times 100}{\sqrt{2}} \% = 0,071 \%$$

$$u_{j \text{ mismatch:adapterand attenuator1}} = \frac{0,02 \times 0,05 \times 100}{\sqrt{2}} \% = 0,071 \%$$

- $u_{j \text{ attenuator 2 and cable 2}}$ : Constant for both stage 1 and 2. Hence this value does not contribute.
- $u_{j \text{ cable 2 and receiving device}}$ : Constant for both stage 1 and 2. Hence this value does not contribute.
- $u_{j \text{ generator and attenuator 1}}$ : Constant for both stage 1 and 2. Hence this value does not contribute.

$$u_{j \text{ mismatch:cable1and adapter}} = \frac{0,07 \times 0,07 \times 0,316^2 \times 100}{\sqrt{2}} \% = 0,035 \%$$

$$u_{j \text{ mismatch:attenuator1and attenuator2}} = \frac{0,05 \times 0,05 \times 0,988^2 \times 100}{\sqrt{2}} \% = 0,173 \%$$

$$u_{j \text{ mismatch:adapterand cable2}} = \frac{0,02 \times 0,07 \times 0,316^2 \times 100}{\sqrt{2}} \% = 0,010 \%$$

- $u_{j \text{ attenuator 2 and receiving device}}$ : Constant for both stage 1 and 2. Hence this value does not contribute.

$$u_{j \text{ mismatch:generatorand adapter}} = \frac{0,2 \times 0,02 \times 0,891^2 \times 0,316^2 \times 100}{\sqrt{2}} \% = 0,022 \%$$

$$u_{j \text{ mismatch:cable1and attenuator2}} = \frac{0,07 \times 0,05 \times 0,316^2 \times 0,988^2 \times 100}{\sqrt{2}} \% = 0,024 \%$$

$$u_{j \text{ mismatch:attenuator1and cable2}} = \frac{0,05 \times 0,07 \times 0,988^2 \times 0,316^2 \times 100}{\sqrt{2}} \% = 0,024 \%$$

$$u_{j \text{ mismatch:adapterand receiving device}} = \frac{0,02 \times 0,2 \times 0,316^2 \times 0,891^2 \times 100}{\sqrt{2}} \% = 0,022 \%$$

$$u_{j \text{ mismatch:generatorand attenuator2}} = \frac{0,2 \times 0,05 \times 0,891^2 \times 0,316^2 \times 0,988^2 \times 100}{\sqrt{2}} \% = 0,055 \%$$

- $u_{j \text{ mismatch: cable 1 and cable 2}}$ : Less than 0,01 % due to the two attenuators, therefore neglected.

$$u_{j \text{ mismatch:attenuator1and receiving device}} = \frac{0,05 \times 0,2 \times 0,988^2 \times 0,316^2 \times 0,891^2 \times 100}{\sqrt{2}} \% = 0,055 \%$$

- $u_{j \text{ mismatch: generator and cable 2}}$ : Less than 0,01 % due to the two attenuators, therefore neglected.
- $u_{j \text{ mismatch: cable 1 and receiving device}}$ : Less than 0,01 % due to the two attenuators, therefore neglected.
- $u_{j \text{ mismatch: generator and receiving device}}$ : Less than 0,01 % due to the two attenuators, therefore neglected.

The combined standard uncertainty of the mismatch is then calculated:

$$u_{\text{cmismatch:directatt.}} = \sqrt{0,071^2 + 0,071^2 + \dots + 0,055^2 + 0,055^2} = 0,306 \%$$

Transforming to logarithmic form (ETR 028 [15], part 2, annex E):  $0,306 \%/11,5 = 0,026$  dB.

The standard uncertainty of the contribution, due to the mismatch in the direct attenuation measurement, is designated throughout all parts of ETR 273 [12] as  $u_{j35}$ . Its value in this example is 0,026 dB.

### 6.8.2.1.2 Contributions from individual components

#### 6.8.2.1.2.1 Signal generator

**Signal generator: absolute output level:** In a verification procedure, the signal generator's absolute level uncertainty contributes equally to both stages of the measurement. The standard uncertainty of the contribution due to the signal generator absolute output level uncertainty is designated throughout all parts of ETR 273 [12] as  $u_{j38}$ .

NOTE 1: In this example case the standard uncertainty of the contribution due to the signal generator absolute output level uncertainty is taken to be 0,00 dB since, once the level has been set in stage one of the procedure, the level is not further adjusted. The uncertainty is therefore assumed to be systematic i.e. it produces the same offset in both stages.

**Signal generator: output level stability:** In any test in which the contribution of the absolute level uncertainty of the signal generator contributes to the combined standard uncertainty of the test i.e. it does not cancel due to the methodology, the contribution from the output level stability is considered to have been included in the signal generator absolute output level,  $u_{j38}$ . Conversely, for any level in which the absolute level uncertainty of the signal generator does not contribute to the combined standard uncertainty, the output level stability of the signal generator should be included. The standard uncertainty of the contribution due to the signal generator output level stability is designated throughout all parts of ETR 273 [12] as  $u_{j39}$ . Its value can be derived from manufacturers' data sheet.

NOTE 2: In this example case the uncertainty of the contribution due to the signal generator output level stability is obtained from the manufacturers data sheet as  $\pm 0,02$  dB. As nothing is said about the distribution of this uncertainty, a rectangular distribution (see ETR 273 [12], part 1, subpart 1, clause 5.1.2) in logs is assumed, and the standard uncertainty is calculated as 0,01155 dB. This is rounded down to 0,01 dB.

#### 6.8.2.1.2.2 Transmitting antenna cable

**Insertion loss: transmitting antenna cable:** The transmitting antenna cable has an insertion loss as well as an uncertainty associated with the measurement of its magnitude. The value of insertion loss and its uncertainty remain valid provided the cable is not used outside the manufacturer's specification. At any given frequency the insertion loss acts as a systematic offset and contributes equally to both stages of the measurement. The standard uncertainty of the contribution due to the insertion loss uncertainty of the transmitting antenna cable is designated throughout all parts of ETR 273 [12] as  $u_{j41}$ .

NOTE 1: In this example case the standard uncertainty of the contribution due to the insertion loss uncertainty of the transmitting antenna cable is taken as 0,00 dB since the uncertainty is systematic i.e. it produces the same offset in both stages.

**Cable factor: transmitting antenna:** Cable factor is defined as the total effect of the antenna cable's influence on the measuring system including its interaction with the site. It consists of the leakage caused by cable screening inefficiency, parasitic effects on the transmitting antenna (acting as a director or reflector) and introducing an unbalanced, common mode current into the dipole balun. In a radiated measurement the standard uncertainty of the cable factor, associated with each cable, is 0,5 dB provided that the precautions detailed in the methods have been observed i.e. routing and dressing of cables with ferrites. If no prevention has been attempted the standard uncertainty is 4,0 dB (justification for these values is given in ETR 273 [12], part 1, subpart 2, annex E). The standard uncertainty of the contribution due to the cable factor of the transmitting antenna cable is designated throughout all parts of ETR 273 [12] as  $u_{j19}$ .

NOTE 2: In this example case the standard uncertainty of the contribution due to the cable factor of the transmitting antenna cable is taken as 0,00 dB since there are no external fields involved other than leakage, which is assumed to have a negligible effect on the measurement.

### 6.8.2.1.2.3 Transmitting antenna attenuator

**Insertion loss: transmitting antenna attenuator:** The transmitting antenna attenuator has an insertion loss as well as an uncertainty associated with the measurement of its magnitude. The value of insertion loss and its uncertainty remain valid provided the attenuator is not used outside the manufacturer's specification. At any given frequency the insertion loss acts as a systematic offset and contributes equally to both stages of the measurement. The standard uncertainty of the contribution, due to the insertion loss uncertainty of the transmitting antenna attenuator, is designated throughout all parts of ETR 273 [12] as  $u_{j40}$ .

NOTE: In this example case the standard uncertainty of the contribution due to the insertion loss uncertainty of the transmitting antenna attenuator is taken as 0,00 dB since the uncertainty is systematic i.e. it produces the same offset in both stages.

### 6.8.2.1.2.4 Adapter

**Insertion loss: adapter:** The adapter has an insertion loss as well as an uncertainty associated with the measurement of its magnitude. The value of insertion loss and its uncertainty remain valid provided the adapter is not used outside the manufacturer's specification. The standard uncertainty of the contribution due to the insertion loss uncertainty of the adapter is designated throughout all parts of ETR 273 [12] as  $u_{j42}$ . Its value can be derived from the manufacturer's data sheet.

NOTE: In this example case the uncertainty of the contribution due to the insertion loss uncertainty of the adapter is obtained from the manufacturer's data sheet as  $\pm 0,10$  dB. As nothing is said about the distribution of this uncertainty, a rectangular distribution (see ETR 273 [12], part 1, subpart 1, clause 5.1.2) in logs is assumed, and the standard uncertainty is calculated as 0,06 dB.

### 6.8.2.1.2.5 Receiving antenna attenuator

**Insertion loss: receiving antenna attenuator:** The attenuator has an insertion loss as well as an uncertainty associated with the measurement of its magnitude. The value of insertion loss and its uncertainty remain valid provided the attenuator is not used outside the manufacturer's specification. At any given frequency the insertion loss acts as a systematic offset and contributes equally to both stages of the measurement. The standard uncertainty of the contribution due to the insertion loss uncertainty of the receiving antenna attenuator is designated throughout all parts of ETR 273 [12] as  $u_{j40}$ .

NOTE: In this example case the standard uncertainty of the contribution due to the insertion loss uncertainty of the receiving antenna attenuator is taken as 0,00 dB since the uncertainty is systematic i.e. it produces the same offset in both stages.

### 6.8.2.1.2.6 Receiving antenna cable

**Insertion loss: receiving antenna cable:** The receiving antenna cable has an insertion loss as well as an uncertainty associated with the measurement of its magnitude. The value of insertion loss and its uncertainty remain valid provided the cable is not used outside the manufacturer's specification. At any given frequency the insertion loss acts as a systematic offset and contributes equally to both stages of the measurement. The standard uncertainty of the contribution, due to the insertion loss uncertainty of the receiving antenna cable, is designated throughout all parts of ETR 273 [12] as  $u_{j41}$ .

NOTE 1: In this example case the standard uncertainty of the contribution due to the insertion loss uncertainty of the receiving antenna cable is taken as 0,00 dB since the uncertainty is systematic i.e. it produces the same offset in both stages.

**Cable factor: receiving antenna cable:** Cable factor is defined as the total effect of the antenna cable's influence on the measuring system including its interaction with the site. It consists of the leakage caused by cable screening inefficiency, parasitic effects on the receiving antenna (acting as a director or reflector) and introducing an unbalanced, common mode current into the dipole balun. In a radiated measurement the standard uncertainty of the cable factor, associated with each cable is 0,5 dB provided that the precautions detailed in the methods have been observed. i.e. routing and dressing of cables with ferrites. If no prevention has been attempted the standard uncertainty is 4,0 dB (justification for these values is given in ETR 273 [12], part 1, subpart 2, annex E). The standard uncertainty of the contribution due to the cable factor of receiving antenna cable is designated throughout all parts of ETR 273 [12] as  $u_{j19}$ .

NOTE 2: In this example case the standard uncertainty of the contribution due to the cable factor of the receiving antenna cable is taken as 0,00 dB since there are no external fields involved other than leakage, which is assumed to have a negligible effect on the measurement.

#### 6.8.2.1.2.7 Receiving device

In this, the first stage of the verification procedure, a reference level is recorded from the receiving device for a particular output level from the signal generator. In the second stage (where the path loss between the two antennas is measured), a second level is recorded on the receiving device. Only in the second stage do the linearity and absolute level uncertainties of the receiver become involved in the calculation of the combined standard uncertainty of the measurement.

**Receiving device: absolute level:** The standard uncertainty of the contribution due to the absolute level uncertainty of the receiving device is designated throughout all parts of ETR 273 [12] as  $u_{j47}$ .

NOTE 1: In this example case the standard uncertainty of the contribution due to the absolute level uncertainty of the receiving device is assumed to be 0,00 dB since, in this part of the measurement, a reference level is recorded.

**Receiving device: linearity:** The standard uncertainty of the contribution due to the receiving device linearity is designated throughout all parts of ETR 273 [12] as  $u_{j48}$ .

NOTE 2: In this example case the standard uncertainty of the contribution due to the receiving device linearity is assumed to be 0,00 dB since, in this part of the measurement, a reference level is recorded.

#### 6.8.2.1.3 Contribution from the random component

**Random uncertainty:** The magnitude can be assessed from multiple measurements of the direct attenuation measurement. The standard uncertainty of the contribution due to the random uncertainty is designated throughout all parts of ETR 273 [12] as  $u_{i01}$ . Its value can then be calculated.

The direct attenuation measurement was repeated 10 times. The following results were obtained in dB $\mu$ V (before correcting for cabling and attenuator network insertion loss):

- 106,8; 107,2; 106,7; 107,0; 107,2; 106,7; 107,1; 106,8; 107,1; 107,0.

Converting to linear terms:

- 0,2188; 0,2291; 0,2163; 0,2239; 0,2291; 0,2163; 0,2265; 0,2188; 0,2265; 0,2239.

The two sums  $X$  and  $Y$  are calculated:

- $X$  = the sum of the measured values = 2,2292 V;
- $Y$  = the sum of the squares of the measured values = 0,4972 V<sup>2</sup>.

$$u_{c \text{ random}} = \sqrt{\frac{Y - \frac{X^2}{n}}{n-1}} = \sqrt{\frac{0,4972 - \frac{2,2292^2}{10}}{10-1}} = 5,444 \times 10^{-3} \text{ (formula 5.6)}$$

As the result is obtained as the mean value of 10 measurements and the standard uncertainty of the random uncertainty is:

$$u_{j \text{ random}} = \frac{5,444 \times 10^{-3}}{0,22292} \times \frac{100}{11,5} = 0,212 \text{ dB}$$

NOTE: In this example case the standard uncertainty of the contribution due to the random uncertainty is 0,212 dB.

#### 6.8.2.1.4 Summary table of contributory components

The uncertainty contributions for stage 1 of the verification procedure are listed in table 3.

**Table 3: Contributions from the direct attenuation measurement**

$u_j$ or $i$	Description of uncertainty contributions	dB
$u_{j35}$	mismatch: direct attenuation measurement	0,03
$u_{j38}$	signal generator: absolute output level	0,00
$u_{j39}$	signal generator: output level stability	0,01
$u_{j41}$	insertion loss: transmitting antenna cable	0,00
$u_{j19}$	cable factor: transmitting antenna	0,00
$u_{j40}$	insertion loss: transmitting antenna attenuator	0,00
$u_{j42}$	insertion loss: adapter	0,06
$u_{j40}$	insertion loss: receiving antenna attenuator	0,00
$u_{j41}$	insertion loss: receiving antenna cable	0,00
$u_{j19}$	cable factor: receiving antenna	0,00
$u_{j47}$	receiving device: absolute level	0,00
$u_{j48}$	receiving device: linearity	0,00
$u_{i01}$	random uncertainty	0,21

The standard uncertainties from table 3 should be combined by RSS in accordance with ETR 273 [12], part 1, subpart 1, clause 5. This gives the combined standard uncertainty ( $u_{c \text{ direct attenuation measurement}}$ ) for the direct attenuation measurement in dB.

The value of  $u_{c \text{ direct attenuation measurement}}$  is calculated as 0,221 dB.

#### 6.8.2.2 Uncertainty contributions: Stage 2: Radiated attenuation measurement

The second stage of the verification procedure is the radiated attenuation measurement which is carried out by removing the adapter and connecting each attenuator to an antenna as shown in figure 23, and recording the new level on the receiving device. The difference in received levels (after allowance for any correction factors and calculations which may be appropriate), for the same signal generator output level, reveals the NSA.

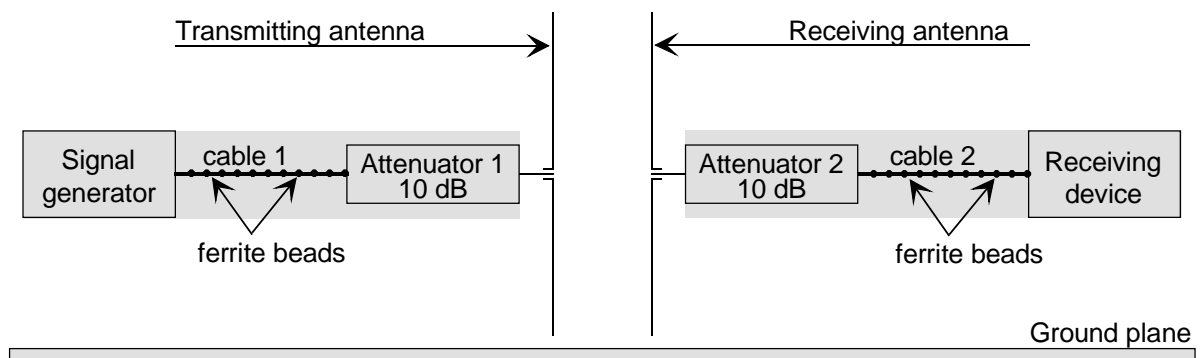

**Figure 23: Stage 2: Radiated attenuation measurement**

Whereas figure 23 shows, schematically, the test equipment set-up for this stage of the verification procedure an analysis diagram of the individual components (each of which contributes its own uncertainty) for this stage of the measurement is shown in figure 24. Again, as stated above, the shaded areas represent components common to both stages of the verification procedure.

##### 6.8.2.2.1 Contributions from the mismatch components

**Mismatch uncertainty transmitting and receiving parts:** The value of the combined standard uncertainty of the contribution due to the mismatch are calculated from the approach described in annex G. For this stage is calculated in two parts. Firstly the standard uncertainty of the contribution due to the mismatch in the transmitting part, i.e. between the signal generator, cable, attenuator and the transmitting antenna and secondly, that for the receiving part, i.e. between the receiving antenna, attenuator, cable and the receiving device.

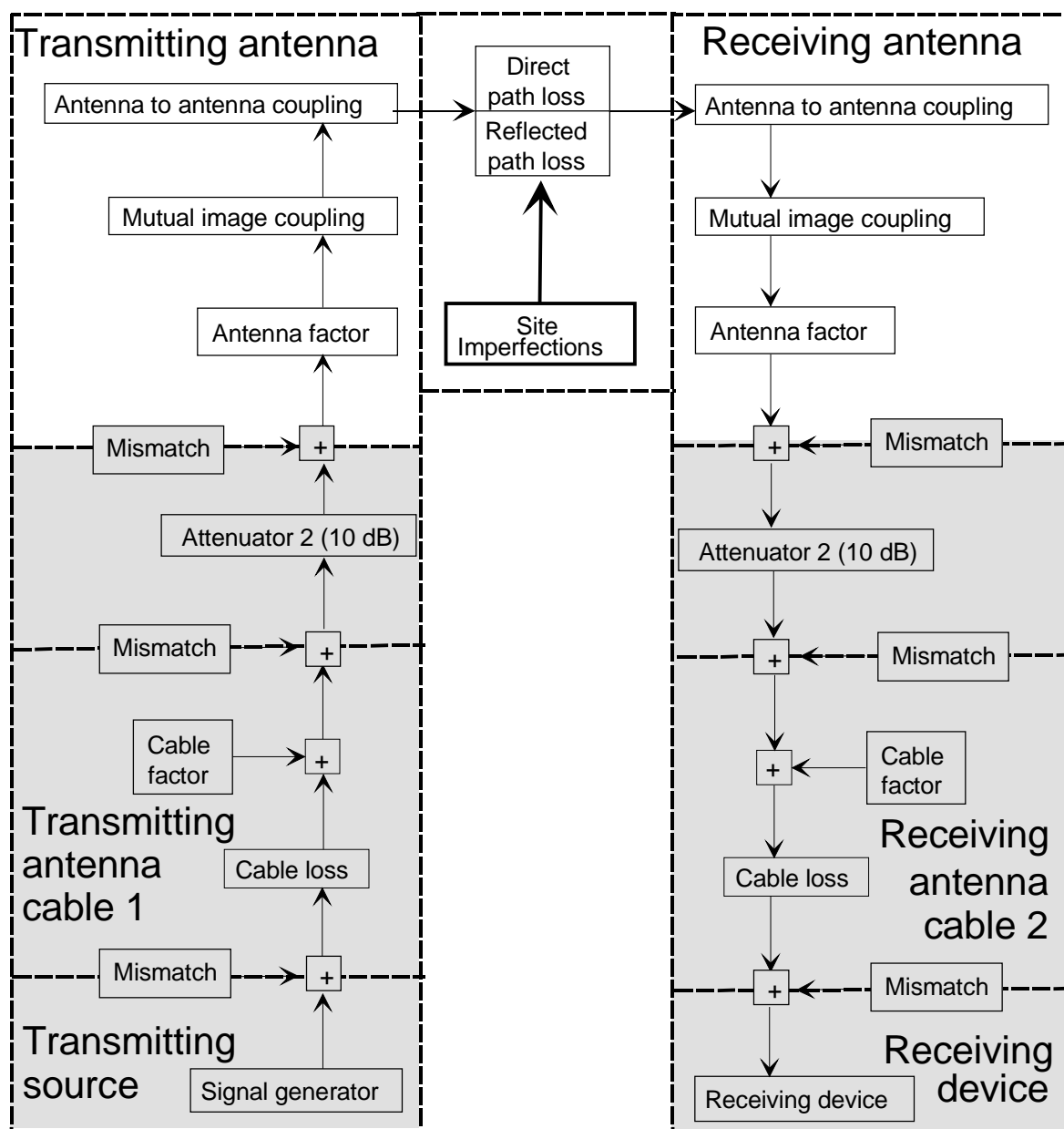

Figure 24: Stage 2: Radiated attenuation measurement individual uncertainty components

**Mismatch: transmitting part:**

Signal generator:	Output reflection coefficient: $ \rho_G $	= 0,20
Cable:	Input and output reflection coefficients: $ S_{11} $ and $ S_{22} $	= 0,07
	Attenuation: 1 dB = $ S_{12}  =  S_{21} $	= 0,891
Attenuator:	Input and output reflection coefficients $ S_{11}  =  S_{22} $	= 0,05
	Attenuation = 10 dB $ S_{12}  =  S_{21} $	= 0,3162
Transmitting antenna:	Input reflection coefficient: $ \rho_{TA} $	= 0,333



All these contributions are U-distributed. Those components that cancel are not calculated. Other contributions are (see annex G):

- $u_{j \text{ mismatch: generator and cable } 1}$ : Constant for both stage 1 and 2. Hence this value does not contribute.
- $u_{j \text{ mismatch: cable 1 and attenuator } 1}$ : Constant for both stage 1 and 2. Hence this value does not contribute.

$$u_{j \text{ mismatch:attenuator\and antenna}} = \frac{0,05 \times 0,333 \times 100}{\sqrt{2}} \% = 1,177\%$$

- $u_{j \text{ generator and attenuator } 1}$ : Constant for both stage 1 and 2. Hence this value does not contribute.

$$u_{j \text{ mismatch:cable\and antenna}} = \frac{0,07 \times 0,333 \times 0,316^2 \times 100}{\sqrt{2}} \% = 0,165\%$$

$$u_{j \text{ mismatch:generator\and antenna}} = \frac{0,2 \times 0,333 \times 0,891^2 \times 0,316^2 \times 100}{\sqrt{2}} \% = 0,373\%$$

The combined standard uncertainty of the mismatch is then calculated:

$$u_{cmismatch:transmitting \text{ part}} = \sqrt{1,177^2 + 0,165^2 + 0,373^2} = 1,25\%$$

transforming to the logarithmic form (ETR 028 [15], part 2, annex E):  $1,25 \% / 11,5 = 0,11 \text{ dB}$ .

The standard uncertainty of the contribution due to the mismatch in the transmitting part, is designated throughout all parts of ETR 273 [12] as  $u_{j36}$ . Its value in this example is 0,11 dB.

#### Mismatch: receiving part:

Receiving antenna:	Input reflection coefficient: $ \rho_{RA} $	= 0,333
Attenuator:	Input and output reflection coefficients $ S_{11}  =  S_{22} $	= 0,05
	Attenuation = 10 dB $ S_{12}  =  S_{21} $	= 0,3162
Cable:	Input and output reflection coefficients: $ S_{11} $ and $ S_{22} $	= 0,07
	Attenuation: 1 dB = $ S_{12}  =  S_{21} $	= 0,891
Receiving device:	Input reflection coefficient: $ \rho_{RD} $	= 0,20

$$u_{j \text{ mismatch:antenna\and attenuator } 2} = \frac{0,333 \times 0,05 \times 100}{\sqrt{2}} \% = 1,177\%$$

- $u_{j \text{ attenuator 2 and cable } 2}$ : Constant for both stage 1 and 2. Hence this value does not contribute.
- $u_{j \text{ cable 2 and receiving device}}$ : Constant for both stage 1 and 2. Hence this value does not contribute.

$$u_{j \text{ mismatch:antenna\and cable } 2} = \frac{0,333 \times 0,07 \times 0,316^2 \times 100}{\sqrt{2}} \% = 0,165\%$$

- $u_{j \text{ attenuator 2 and receiving device}}$ : Constant for both stage 1 and 2. Hence this value does not contribute.

$$u_{j \text{ mismatch:antenna\and receiving device}} = \frac{0,333 \times 0,2 \times 0,316^2 \times 0,891^2 \times 100}{\sqrt{2}} \% = 0,373\%$$

The combined standard uncertainty of the mismatch is then calculated:

$$u_{\text{mismatch:receiving part}} = \sqrt{1,177^2 + 0,165^2 + 0,373^2} = 1,25\%$$

Transforming to the logarithmic form (ETR 028 [15], part 2, annex E):  $1,25\% / 11,5 = 0,11$  dB.

The standard uncertainty of the contribution due to the mismatch in the receiving part is designated throughout all parts of ETR 273 [12] as  $u_{j37}$ . Its value in this example is 0,11 dB.

## 6.8.2.2.2 Contributions from individual components

### 6.8.2.2.2.1 Signal generator

**Signal generator: absolute output level:** In a verification procedure, the signal generator's absolute level uncertainty contributes equally to both stages of the measurement. The standard uncertainty of the contribution due to the signal generator absolute output level uncertainty is designated throughout all parts of ETR 273 [12] as  $u_{j38}$ .

NOTE 1: In this example case the standard uncertainty of the contribution due to the signal generator absolute output level uncertainty is taken to be 0,00 dB since, once the level has been set in stage one of the procedure, the level is not further adjusted. The uncertainty is therefore assumed to be systematic i.e. it produces the same offset in both stages.

**Signal generator: output level stability:** In any test in which the contribution of the absolute level uncertainty of the signal generator contributes to the combined standard uncertainty of the test i.e. it does not cancel due to the methodology, the contribution from the output level stability is considered to have been included in the signal generator absolute output level,  $u_{j38}$ . Conversely, for any level in which the absolute level uncertainty of the signal generator does not contribute to the combined standard uncertainty, the output level stability of the signal generator should be included. The standard uncertainty of the contribution due to the signal generator output level stability is designated throughout all parts of ETR 273 [12] as  $u_{j39}$ . Its value can be derived from manufacturers' data sheet.

NOTE 2: In this example case the uncertainty of the contribution due to the signal generator output level stability is obtained from the manufacturers data sheet as  $\pm 0,02$  dB. As nothing is said about the distribution of this uncertainty, a rectangular distribution (see ETR 273 [12], part 1, subpart 1, clause 5.1.2) in logs is assumed, and the standard uncertainty is calculated as 0,01155 dB. This is rounded down to 0,01 dB.

### 6.8.2.2.2.2 Transmitting antenna cable

**Insertion loss: transmitting antenna cable:** The transmitting antenna cable has an insertion loss as well as an uncertainty associated with the measurement of its magnitude. The value of insertion loss and its uncertainty remain valid provided the cable is not used outside the manufacturer's specification. At any given frequency the insertion loss acts as a systematic offset and contributes equally to both stages of the measurement. The standard uncertainty of the contribution, due to the insertion loss uncertainty of the transmitting antenna cable, is designated throughout all parts of ETR 273 [12] as  $u_{j41}$ .

NOTE 1: In this example case the standard uncertainty of the contribution due to the insertion loss uncertainty of the transmitting antenna cable is taken as 0,00 dB since the uncertainty is systematic i.e. it produces the same offset in both stages.

**Cable factor: transmitting antenna cable:** Cable factor is defined as the total effect of the antenna cable's influence on the measuring system including its interaction with the site. It consists of the leakage caused by cable screening inefficiency, parasitic effects on the transmitting antenna (acting as a director or reflector) and introducing an unbalanced, common mode current into the dipole balun. In a radiated measurement the standard uncertainty of the cable factor, associated with each cable, is 0,5 dB provided that the precautions detailed in the methods have been observed. i.e. routing and dressing of cables with ferrites. If no prevention has been attempted the standard uncertainty is 4,0 dB (justification for these values is given in ETR 273 [12], part 1, subpart 2, annex E). The standard uncertainty of the contribution due to the cable factor of the receiving antenna cable is designated throughout all parts of ETR 273 [12] as  $u_{j19}$ .

NOTE 2: In this example case the standard uncertainty of the contribution due to the cable factor of the transmitting antenna cable is taken as 0,50 dB since the precautions detailed in the methods are assumed to have been observed.

### 6.8.2.2.2.3 Transmitting antenna attenuator

**Insertion loss: transmitting antenna attenuator:** The transmitting antenna attenuator has an insertion loss as well as an uncertainty associated with the measurement of its magnitude. The value of insertion loss and its uncertainty remain valid provided the attenuator is not used outside the manufacturer's specification. At any given frequency the insertion loss acts as a systematic offset and contributes equally to both stages of the measurement. The standard uncertainty of the contribution, due to the insertion loss uncertainty of the transmitting antenna attenuator, is designated throughout all parts of ETR 273 [12] as  $u_{j40}$ .

NOTE: In this example case the standard uncertainty of the contribution due to the insertion loss uncertainty of the transmitting antenna attenuator is taken as 0,00 dB since the uncertainty is systematic i.e. it produces the same offset in both stages.

### 6.8.2.2.2.4 Transmitting antenna

**Antenna: antenna factor of the transmitting antenna:** Uncertainty is introduced as a result of the inaccurate knowledge of the antenna factor of the transmitting antenna. The antenna factor contributes only to the radiated part of this procedure. The standard uncertainty of the contribution due to the antenna factor uncertainty of the transmitting antenna is designated throughout all parts of ETR 273 [12] as  $u_{j44}$ . For ANSI dipoles the value should be obtained from table 4.

**Table 4: Uncertainty contribution of the antenna factor of the transmitting antenna**

Frequency	Standard uncertainty of the contribution
30 MHz ≤ frequency < 80 MHz	1,73 dB
80 MHz ≤ frequency < 180 MHz	0,60 dB
frequency ≥ 180 MHz	0,30 dB

NOTE 1: For other antenna types the values should be taken from manufacturers' data sheets. If a value is not given the standard uncertainty is 1,0 dB.

NOTE 2: In this example case the standard uncertainty of the contribution due to the antenna factor uncertainty of the transmitting antenna is 0,30 dB since ANSI dipoles have been used and the frequency is above 180 MHz.

**Antenna: tuning of the transmitting antenna:** Uncertainty is introduced as a result of the inaccurate tuning of the transmitting antenna. This only occurs in stage two of the measurement and therefore only contributes to this stage. The standard uncertainty of the contribution, due to the tuning uncertainty of the transmitting antenna, is designated throughout all parts of ETR 273 [12] as  $u_{j46}$ .

NOTE 3: In this example case the standard uncertainty of the contribution due to the tuning uncertainty of the transmitting antenna is taken as 0,06 dB (see annex A).

**Position of the phase centre: transmitting antenna:** Uncertainty is introduced as a result of the inaccurate positioning of the phase centre of the transmitting antenna. This only occurs in stage two of the measurement. The standard uncertainty of the contribution, due to the uncertainty in the position of the phase centre of the transmitting antenna, is designated throughout all parts of ETR 273 [12] as  $u_{j22}$ .

NOTE 4: In this example case the standard uncertainty of the contribution due to the uncertainty in the position of the phase centre of the transmitting antenna has been calculated from ( $\pm$ (the offset from axis of rotation)/(range length) x 100 %). The positioning uncertainty is  $\pm 0,01$  m and therefore the worst case uncertainty =  $0,01/3,0 = 0,333$  %. As the offset can be anywhere between these limits, the uncertainty is taken to be rectangularly distributed (see ETR 273 [12], part 1, subpart 1, clause 5.1.2) and the standard uncertainty is calculated as 0,192 %. This is transformed to the logarithmic form (ETR 028 [15], part 2, annex E), to be 0,02 dB.

## 6.8.2.2.2.5 Site factors

**Ambient effect:** Uncertainty is introduced as a result of local ambient signals raising the noise floor at the measurement frequency. The standard uncertainty of the contribution due to the ambient effect is designated throughout all parts of ETR 273 [12] as  $u_{j34}$ . The values of the standard uncertainty should be taken from table 5.

**Table 5: Uncertainty contribution: Ambient effect**

Receiving device noise floor (generator OFF) is within:	Standard uncertainty of the contribution
3 dB of measurement	1,57 dB
3 dB to 6 dB of measurement	0,80 dB
6 dB to 10 dB of measurement	0,30 dB
10 dB to 20 dB of measurement	0,10 dB
20 dB or more of the measurement	0,00 dB

NOTE 1: In this example case the standard uncertainty of the contribution due to the ambient effect is taken as 0,00 dB, since the chamber is assumed to be shielded.

**Mutual coupling: transmitting antenna to its images in the absorbing material:** This uncertainty is the effect of the change produced in the antenna's input impedance and/or gain. The standard uncertainty of the contribution due to the mutual coupling of the transmitting antenna to its images in the absorbing materials is designated throughout all parts of ETR 273 [12] as  $u_{j07}$ .

NOTE 2: In this example case the standard uncertainty of the contribution due to the mutual coupling of the transmitting antenna to its images in the absorbing materials is taken as 0,5 dB (see annex A).

**Mutual coupling: transmitting antenna to its image in the ground plane:** This uncertainty is the effect of the change produced in the antenna's input impedance and/or gain. The standard uncertainty of the contribution due to the mutual coupling of the transmitting antenna to its image in the ground plane, designated throughout all parts of ETR 273 [12] as  $u_{j15}$ , has a value of 0,00 dB for ANSI dipoles since it is included, where significant, in the mutual coupling and mismatch loss correction factors (see table A.20). For other dipoles the value can be obtained from table 6.

**Table 6: Uncertainty contribution of the mutual coupling between the transmitting antenna to its image in the ground plane**

Spacing between the antenna and the ground plane	Standard uncertainty of the contribution
<b>For a vertically polarized antenna</b>	
spacing $\leq 1,25 \lambda$	0,15 dB
spacing $> 1,25 \lambda$	0,06 dB
<b>For a horizontally polarized antenna</b>	
spacing $< \lambda/2$	1,15 dB
$\lambda/2 \leq$ spacing $< 3\lambda/2$	0,58 dB
$3\lambda/2 \leq$ spacing $< 3\lambda$	0,29 dB
spacing $\geq 3\lambda$	0,15 dB

NOTE 3: In this example case the standard uncertainty of the contribution due to mutual coupling between the transmitting antenna and its image in the ground plane is taken as 0,00 dB as we are assuming the use of ANSI dipoles.

**Mutual coupling: transmitting antenna to receiving antenna:** This is the effect produced by any change in the gains of the antennas which results from their close spacing. The standard uncertainty of the contribution due to the mutual coupling of the transmitting antenna to receiving antenna, is designated throughout all parts of ETR 273 [12] as  $u_{j10}$ . It has a standard uncertainty of 0,00 dB for ANSI dipoles since it is included, where significant, in the mutual coupling and mismatch loss correction factors. For non-ANSI dipoles the standard uncertainty can be taken from table 7.

**Table 7: Uncertainty contribution of the mutual coupling between the transmitting and receiving antenna**

Frequency	Standard uncertainty of the contribution (3 m range)	Standard uncertainty of the contribution (10 m range)
30 MHz ≤ frequency < 80 MHz	1,73 dB	0,60 dB
80 MHz ≤ frequency < 180 MHz	0,6 dB	0,00 dB
frequency ≥ 180 MHz	0,00 dB	0,00 dB

NOTE 4: In this example case the standard uncertainty of the contribution due to mutual coupling between the transmitting and receiving antennas is taken as 0,00 dB as we are using ANSI dipoles.

**Mutual coupling: interpolation of mutual coupling and mismatch loss correction factors, only for ANSI dipoles:**

The standard uncertainty of the contribution, due to the interpolation of mutual coupling and mismatch loss correction factors, is designated throughout all parts of ETR 273 [12] as  $u_{j12}$ . It has, for spot frequencies given in table A.20, a value of 0,00 dB. However, for all other frequencies, the standard uncertainty should be obtained from table 8.

**Table 8: Uncertainty contribution of the interpolation of mutual coupling and mismatch loss correction factors**

Frequency (MHz)	Standard uncertainty of the contribution
for a spot frequency given in the table	0,00 dB
30 MHz ≤ frequency < 80 MHz	0,58 dB
80 MHz ≤ frequency < 180 MHz	0,17 dB
frequency ≥ 180 MHz	0,00 dB

NOTE 5: In this example case the standard uncertainty of the contribution, due to the interpolation of mutual coupling and mismatch loss correction factors, is taken as 0,00 dB as the frequency is above 180 MHz.

**Range length:** This contribution is associated with the curvature of the phase front from the transmitting antenna to the receiving antenna. The standard uncertainty of the contribution, due to range length, is designated throughout all parts of ETR 273 [12] as  $u_{j16}$ . The standard uncertainty is 0,00 dB if ANSI dipoles are used. For other types of antenna the standard uncertainty of the contribution should be obtained from table 9.

**Table 9: Uncertainty contribution of the range length (verification)**

Range length (i.e. the horizontal distance between phase centres)	Standard uncertainty of the contribution
$(d_1+d_2)^2/4\lambda \leq \text{range length} < (d_1+d_2)^2/2\lambda$	1,26 dB
$(d_1+d_2)^2/2\lambda \leq \text{range length} < (d_1+d_2)^2/\lambda$	0,30 dB
$(d_1+d_2)^2/\lambda \leq \text{range length} < 2(d_1+d_2)^2/\lambda$	0,10 dB
range length ≥ $2(d_1+d_2)^2/\lambda$	0,00 dB

NOTE 6: In table 9,  $d_1$  and  $d_2$  are the maximum dimensions of the antennas.

NOTE 7: In this example case the standard uncertainty of the contribution, due to the range length, is taken as 0,00 dB as we are using ANSI dipoles.

**Reflectivity of absorbing material: transmitting antenna to the receiving antenna:** This uncertainty is associated with the magnitude of the reflections occurring from the side walls, end walls and ceiling. These magnitudes are a function of the quality of the absorber at the frequency of test. The standard uncertainty of the contribution, due to reflectivity of the absorber material between the transmitting antenna and the receiving antenna, is designated throughout all parts of ETR 273 [12] as  $u_{j03}$ . The relevant value for this contribution should be taken from table 10.

**Table 10: Uncertainty contribution of the reflectivity of absorbing material between the transmitting and receiving antennas**

Reflectivity of the absorbing material	Standard uncertainty of the contribution
reflectivity < 10 dB	4,76 dB
10 dB ≤ reflectivity < 15 dB	3,92 dB
15 dB ≤ reflectivity < 20 dB	2,56 dB
20 dB ≤ reflectivity < 30 dB	1,24 dB
reflectivity ≥ 30 dB	0,74 dB

NOTE 8: In this example case the standard uncertainty of the contribution, due to the reflectivity of absorber material between the transmitting antenna and the receiving antenna, is taken as 2,56 dB since it is assumed that the absorber has a reflectivity in the range 15 dB to 20 dB.

**Mutual coupling: receiving antenna to its images in the absorbing material:** This uncertainty is the effect of the change produced in the antenna's input impedance and/or gain. The standard uncertainty of the contribution, due to the mutual coupling of the receiving antenna to its images in the absorbing material, is designated throughout all parts of ETR 273 [12] as  $u_{j07}$ .

NOTE 9: In this example case the standard uncertainty of the contribution due to the mutual coupling of the receiving antenna to its images in the absorbing material is taken as 0,5 dB.

**Mutual coupling: receiving antenna to its image in the ground plane:** This uncertainty is the effect of the change produced in the antenna's input impedance and/or gain. The standard uncertainty of the contribution, due to the mutual coupling of the receiving antenna to its image in the ground plane, is designated throughout all parts of ETR 273 [12] as  $u_{j15}$ . It has a value of 0,00 dB for ANSI dipoles since it is included, where significant, in the mutual coupling and mismatch loss correction factors. For other antennas the value can be obtained from table 11.

**Table 11: Uncertainty contribution of the mutual coupling between the receiving antenna and its image in the ground plane**

Spacing between the antenna and the ground plane	Standard uncertainty of the contribution
<b>For a vertically polarized antenna</b>	
spacing ≤ 1,25 λ	0,15 dB
spacing > 1,25 λ	0,06 dB
<b>For a horizontally polarized antenna</b>	
spacing < λ/2	1,15 dB
λ/2 ≤ spacing < 3λ/2	0,58 dB
3λ/2 ≤ spacing < 3λ	0,29 dB
spacing ≥ 3λ	0,15 dB

NOTE 10: In this example case the standard uncertainty of the contribution due to the mutual coupling between the receiving dipole and its image in the ground plane is taken as 0,00 dB as we are using ANSI dipoles.

#### 6.8.2.2.2.6 Receiving antenna

**Correction: measurement distance:** For verification procedures only one stage involves a radiated measurement and hence no correction can be applied i.e. the uncertainty contribution is 0,00 dB. The standard uncertainty of the contribution, due to the correction for measurement distance, is designated throughout all parts of ETR 273 [12] as  $u_{j18}$ .

**Correction: off boresight angle in elevation plane:** For verification procedures only one stage involves a radiated measurement and hence no correction can be applied i.e. the uncertainty contribution is 0,00 dB. The standard uncertainty of the contribution, due to the correction for off boresight angle in elevation plane is designated throughout all parts of ETR 273 [12] as  $u_{j17}$ .

**Antenna: antenna factor of the receiving antenna:** Uncertainty is introduced as a result of the inaccurate knowledge of the antenna factor of the receiving antenna. The antenna factor contributes only to the radiated part of this procedure. The standard uncertainty of the contribution due to the antenna factor uncertainty of the receiving antenna is designated throughout all parts of ETR 273 [12] as  $u_{j44}$ . For ANSI dipoles the value should be obtained from table 12.

**Table 12: Uncertainty contribution of the antenna factor of the receiving antenna**

Frequency	Standard uncertainty of the contribution
30 MHz ≤ frequency < 80 MHz	1,73 dB
80 MHz ≤ frequency < 180 MHz	0,60 dB
frequency ≥ 180 MHz	0,30 dB

NOTE 3: For other antenna types the figures should be taken from manufacturers data sheets. If a figure is not given the standard uncertainty is 1,0 dB.

NOTE 4: In this example case the standard uncertainty of the contribution due to the antenna factor uncertainty of the receiving antenna is 0,30 dB since ANSI dipoles have been used and the frequency is above 180 MHz.

**Antenna: tuning of the receiving antenna:** Uncertainty is introduced as a result of the inaccurate tuning of the receiving antenna. This only occurs in stage two of the measurement and therefore does not cancel. The standard uncertainty of the contribution, due to the tuning uncertainty of the receiving antenna, is designated throughout all parts of ETR 273 [12] as  $u_{j46}$ .

NOTE 5: In this example case the standard uncertainty of the contribution due to the tuning uncertainty of the receiving antenna is taken as 0,06 dB (see annex A).

**Position of the phase centre: receiving antenna:** Uncertainty is introduced as a result of the inaccurate positioning of the phase centre of the receiving antenna. This only occurs in stage two of the measurement. The standard uncertainty of the contribution, due to the uncertainty in the position of the phase centre of the receiving antenna, is designated throughout all parts of ETR 273 [12] as  $u_{j22}$ .

NOTE 6: In this example case the standard uncertainty of the contribution due to the position of the phase centre of the receiving antenna has been calculated from  $\pm$  (the offset) / (range length) x 100 %. The positioning uncertainty is  $\pm 0,01$  m and therefore the worst case uncertainty =  $0,01/3,0 = 0,333$  %. As the offset can be anywhere between these limits, the uncertainty is taken to be rectangularly distributed (see ETR 273 [12], part 1, subpart 1, clause 5.1.2) and the standard uncertainty is calculated as 0,192 %. This is transformed to the logarithmic form (ETR 028 [15], part 2, annex E), to be 0,02 dB.

#### 6.8.2.2.7 Receiving antenna attenuator

**Insertion loss: receiving antenna attenuator:** The attenuator has an insertion loss as well as an uncertainty associated with the measurement of its magnitude. The value of insertion loss and its uncertainty remain valid provided the attenuator is not used outside the manufacturer's specification. At any given frequency the insertion loss acts as a systematic offset and contributes equally to both stages of the measurement. The standard uncertainty of the contribution due to the insertion loss uncertainty of the receiving antenna attenuator is designated throughout all parts of ETR 273 [12] as  $u_{j40}$ .

NOTE: In this example case the standard uncertainty of the contribution, due to the insertion loss uncertainty of the transmitting antenna attenuator, is taken as 0,00 dB since the uncertainty is systematic i.e. it produces the same offset in both stages.

#### 6.8.2.2.8 Receiving antenna cable

**Insertion loss: receiving antenna cable:** The receiving antenna cable has an insertion loss as well as an uncertainty associated with the measurement of its magnitude. The value of insertion loss and its uncertainty remain valid provided the cable is not used outside the manufacturer's specification. At any given frequency the insertion loss acts as a systematic offset and contributes equally to both stages of the measurement. The standard uncertainty of the contribution due to the insertion loss uncertainty of the receiving antenna cable is designated throughout all parts of ETR 273 [12] as  $u_{j41}$ .

NOTE 1: In this example case the standard uncertainty of the contribution due to the insertion loss uncertainty of the transmitting antenna cable is taken as 0,00 dB since the uncertainty is systematic i.e. it produces the same offset in both stages.

**Cable factor: receiving antenna:** Cable factor is defined as the total effect of the antenna cable's influence on the measuring system including its interaction with the site. It consists of the leakage caused by cable screening inefficiency, parasitic effects on the receiving antenna (acting as a director or reflector) and introducing an unbalanced, common mode current into the dipole balun. In a radiated measurement the standard uncertainty of the cable factor, associated with each cable, is 0,5 dB provided that the precautions detailed in the methods have been observed. i.e. routing and dressing of cables with ferrites. If no prevention has been attempted the standard uncertainty is 4,0 dB (justification for these values is given in ETR 273 [12], part 1, subpart 2, annex E). The standard uncertainty of the contribution due to the cable factor of the receiving antenna cable is designated throughout all parts of ETR 273 [12] as  $u_{j19}$ .

NOTE 2: In this example case the standard uncertainty of the contribution due to the cable factor of the receiving antenna cable is taken as 0,50 dB since the precautions detailed in the methods are assumed to have been observed.

#### 6.8.2.2.2.9 Receiving device

The first stage of the verification procedure involved setting a reference level on the receiving device for a particular output level from the signal generator. In this the second stage (where the path loss between two antennas is measured), a second level is obtained which results in linearity and absolute level uncertainties becoming involved in the calculation of the combined standard uncertainty for the measurement.

**Receiving device: absolute level:** This uncertainty only contributes during the second stage of the procedure if the input attenuation range setting on the receiving device has been changed from its setting in the first stage. The standard uncertainty of the contribution due to the receiving device absolute level uncertainty is designated throughout all parts of ETR 273 [12] as  $u_{j47}$ .

NOTE 1: In this example case the standard uncertainty of the contribution due to the receiving device absolute level uncertainty (a range change is assumed) is obtained from the manufacturers data as  $\pm 1,0$  dB. This is taken as being rectangularly distributed (see ETR 273 [12], part 1, subpart 1, clause 5.1.2), so the standard uncertainty is calculated as 0,58 dB.

**Receiving device: linearity:** The standard uncertainty of the contribution due to the receiving device linearity, designated throughout all parts of ETR 273 [12] as  $u_{j48}$ , always contributes during the second stage of the procedure unless there has been a range change in which case it is included in the receiving device absolute level uncertainty  $u_{j47}$ .

NOTE 2: In this example case a range change has been assumed therefore the contribution is 0,00 dB.

#### 6.8.2.2.3 Contribution from the random component

**Random uncertainty:** The magnitude can be assessed from multiple measurements of the radiated attenuation measurements. The standard uncertainty of the contribution due to the random uncertainty is designated throughout all parts of ETR 273 [12] as  $u_{i01}$ .

The radiated attenuation measurement was repeated 10 times. The following results were obtained in dB $\mu$ V (before correcting for cabling and attenuator network insertion loss):

- 65,4; 63,4; 66,0; 65,3; 63,0; 64,9; 65,2; 66,8; 65,5; 63,7.

Converting to linear terms:

- $1,862 \times 10^{-3}$ ;  $1,479 \times 10^{-3}$ ;  $1,995 \times 10^{-3}$ ;  $1,841 \times 10^{-3}$ ;  $1,413 \times 10^{-3}$ ;  $1,758 \times 10^{-3}$ ;  $1,820 \times 10^{-3}$ ;  $2,188 \times 10^{-3}$ ;  $1,884 \times 10^{-3}$ ;  $1,531 \times 10^{-3}$ .

The two sums  $X$  and  $Y$  are calculated:

- $X =$  the sum of the measured values =  $17,77 \times 10^{-3}$ ;
- $Y =$  the sum of the squares of the measured values =  $32,10 \times 10^{-6} \text{ V}^2$ .



$$u_{c \text{ random}} = \sqrt{\frac{Y - \frac{X^2}{n}}{n-1}} = \sqrt{\frac{32,10 \times 10^{-6} - \frac{(17,77 \times 10^{-3})^2}{10}}{10-1}} = 238,3 \times 10^{-6} \text{ (formula 5.6)}$$

As the result is obtained as the mean value of 10 measurements and the standard uncertainty of the random uncertainty is:

$$u_{j \text{ random}} = \frac{238,3 \times 10^{-6}}{1,777 \times 10^{-3}} \times \frac{100}{11,5} = 1,17 \text{ dB}$$

NOTE: In this example case the standard uncertainty of the contribution due to the random uncertainty is 1,17 dB.

#### 6.8.2.2.4 Summary table of contributory components

All the uncertainty contributions to this part of the procedure are listed in table 13.

**Table 13: Contributions from the radiated attenuation measurement**

$u_j$ or $u_i$	Description of uncertainty contributions	dB
$u_{j36}$	mismatch: transmitting part	0,11
$u_{j37}$	mismatch: receiving part	0,11
$u_{j38}$	signal generator: absolute output level	0,00
$u_{j39}$	signal generator: output level stability	0,01
$u_{j41}$	insertion loss: transmitting antenna cable	0,00
$u_{j19}$	cable factor: transmitting antenna	0,50
$u_{j40}$	insertion loss: transmitting antenna attenuator	0,00
$u_{j44}$	antenna: antenna factor of the transmitting antenna	0,30
$u_{j46}$	antenna: tuning of the transmitting antenna	0,06
$u_{j22}$	position of the phase centre: transmitting antenna	0,02
$u_{j34}$	ambient effect	0,00
$u_{j07}$	mutual coupling: transmitting antenna to its images in the absorbing material	0,50
$u_{j15}$	mutual coupling: transmitting antenna to its image in the ground plane	0,00
$u_{j10}$	mutual coupling: transmitting antenna to the receiving antenna	0,00
$u_{j12}$	mutual coupling: interpolation of mutual coupling and mismatch loss correction factors	0,00
$u_{j16}$	range length	0,00
$u_{j03}$	reflectivity of absorber material: transmitting antenna to the receiving antenna	2,56
$u_{j07}$	mutual coupling: receiving antenna to its images in the absorbing material	0,50
$u_{j15}$	mutual coupling: receiving antenna to its image in the ground plane	0,00
$u_{j18}$	correction: measurement distance	0,00
$u_{j17}$	correction: off boresight angle in the elevation plane	0,00
$u_{j44}$	antenna: antenna factor of the receiving antenna	0,30
$u_{j46}$	antenna: tuning of the receiving antenna	0,06
$u_{j22}$	position of the phase centre: receiving antenna	0,02
$u_{j40}$	insertion loss: receiving antenna attenuator	0,00
$u_{j41}$	insertion loss: receiving antenna cable	0,00
$u_{j19}$	cable factor: receiving antenna	0,50
$u_{j47}$	receiving device: absolute level	0,58
$u_{j48}$	receiving device: linearity	0,00
$u_{i01}$	random uncertainty	1,17

The standard uncertainties from table 13 should be combined by RSS in accordance with ETR 273 [12], part 1, subpart 1, clause 5. This gives the combined standard uncertainty ( $u_{c \text{ NSA measurement}}$ ) for the NSA measurement in dB.

The value of  $u_{c \text{ NSA measurement}}$  is calculated as 3,08 dB.

### 6.8.2.2.5 Expanded uncertainty for the verification procedure

The combined standard uncertainty of the results of the verification procedure is the combination of the components outlined in clauses 6.8.2.1.4 and 6.8.2.2.4. The components to be combined are  $u_c$  *direct attenuation measurement* and  $u_c$  *NSA measurement*\*

$$u_c = \sqrt{0,221^2 + 3,08^2} = 3,08 \text{ dB}$$

The expanded uncertainty is  $\pm 1,96 \times 3,08 \text{ dB} = \pm 6,04 \text{ dB}$  at a 95 % confidence level.

## 6.8.3 Example 2: Measurement of a transmitter parameter (spurious emission)

For the measurement of the effective radiated power in a spurious emission two stages of test are involved. The first stage (the EUT measurement) is to measure on the receiving device, a level from the EUT. The second stage (the substitution) involves replacing the EUT with a substitution antenna and signal source and adjusting the output level of the signal generator until the same level as in stage one is achieved on the receiving device.

### 6.8.3.1 Uncertainty contributions: Stage 1: EUT measurement

The first stage of the spurious emission measurement is to measure on the receiving device, a level from the EUT. This is normally carried out with a broadband antenna and receiver combination as shown in figure 25. The components shown shaded are common to both stages of the test.

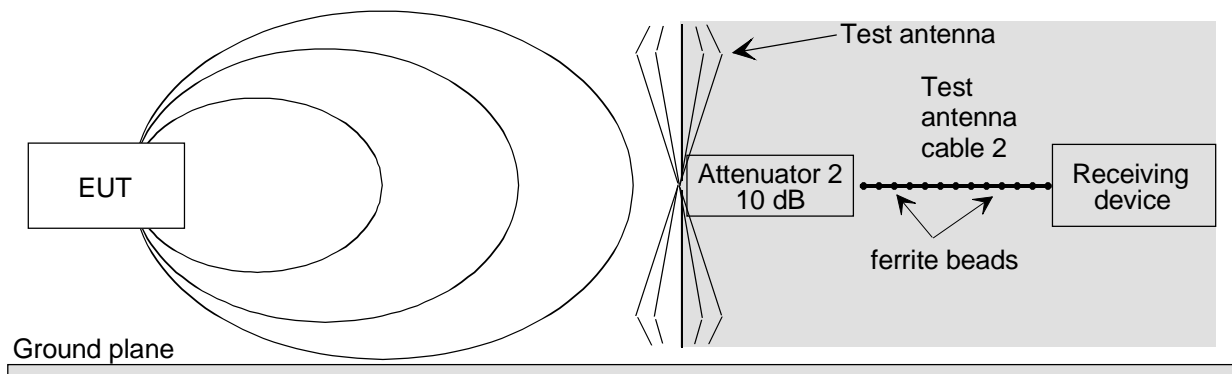

**Figure 25: Stage 1: EUT measurement**

Due to the commonality of all of the components from the test antenna to the receiver in both stages of the test, the mismatch uncertainty contributes identically to both stages and hence does not contribute to the combined standard uncertainty of the measurement. Similarly, for the systematic uncertainty contributions (e.g. test antenna cable loss etc.) of the individual components.

Whereas figure 25 shows, schematically, the test equipment set-up for this stage of the spurious emission measurement, an analysis diagram of the individual components (each of which contributes its own uncertainty) for this stage of the measurement is shown in figure 26. Again, as stated above, the shaded areas represent components common to both stages of the spurious emissions measurement.

#### 6.8.3.1.1 Contributions from the mismatch components

**Mismatch: receiving part:** The uncertainty contribution due to the mismatch for the receiving part from the test antenna to the receiver, can be calculated from the approach described in annex G. All the individual contributions are U-distributed.

NOTE 1: In this example the value taken for the signal generator output reflection coefficient is the worst case value over the frequency band of interest. Similarly for the cable, adapter and attenuator VSWRs.

NOTE 2: The attenuation values of the cables and attenuators should be obtained from the data sheets/calibration records at the specific frequency of the test, along with the associated uncertainties for these values.

The mismatch uncertainty between the test antenna and the receiving device however, contributes equally to both stages of the test and therefore has no contribution to the combined standard uncertainty. Therefore it is not calculated.

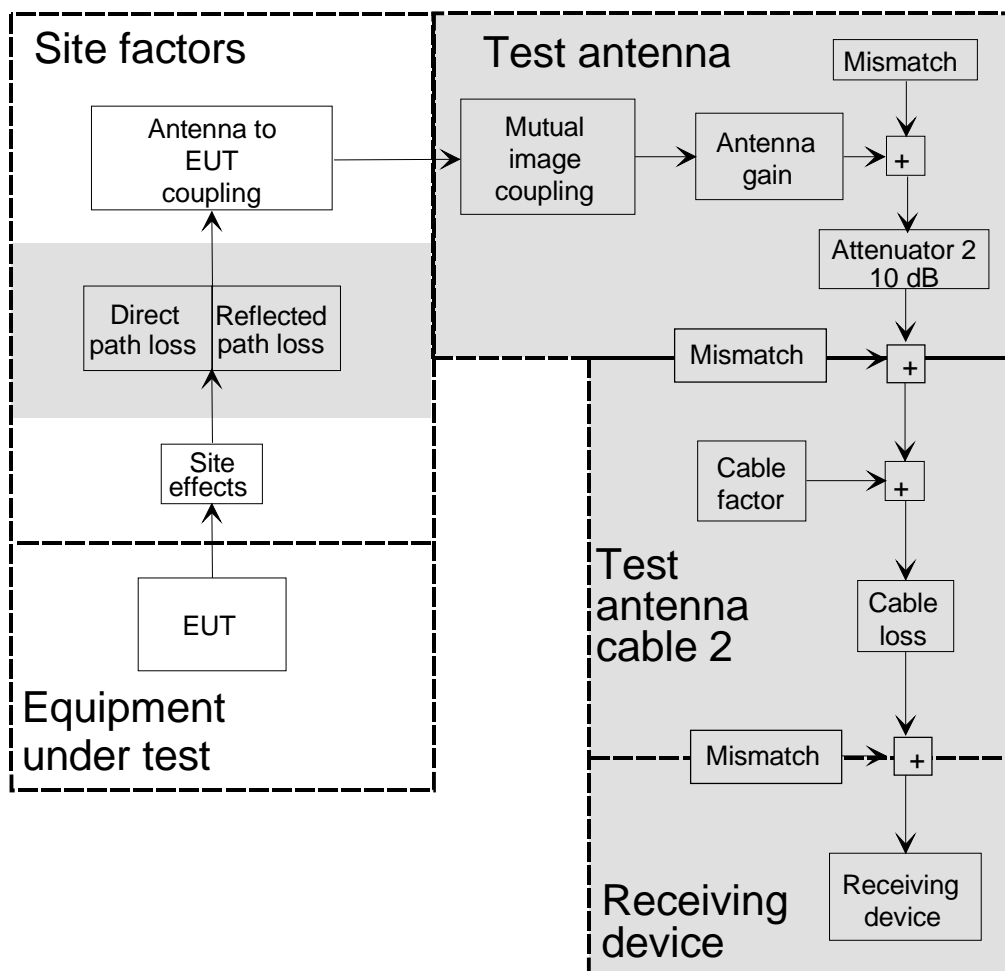

Figure 26: Stage 1: EUT measurement individual uncertainty components

The standard uncertainty of the contribution, due to the mismatch in the receiving part, is designated throughout all parts of ETR 273 [12] as  $u_{j37}$ .

NOTE 3: In this example case the standard uncertainty of the contribution due to mismatch in the receiving part is taken as 0,00 dB, since the uncertainty is assumed to be systematic i.e. it is assumed constant and common to both stages of the measurement.

### 6.8.3.1.2 Contributions from the individual components

#### 6.8.3.1.2.1 EUT

**EUT: influence of setting the power supply on the spurious emission level:** This is the resulting uncertainty caused by the uncertainty of setting of the power supply level. In this case normal supply conditions are assumed, not extreme. The supply voltage uncertainty is taken to be  $\pm 100$  mV so the uncertainty caused by this supply voltage uncertainty is calculated using the dependency function (ETR 028 [15], part 2, annex C, table C.1: "Equipment under test dependency functions and uncertainties") whose mean value is 10 %/V and whose standard uncertainty is 3 %/V. The standard uncertainty of the spurious emission level uncertainty caused by power supply voltage uncertainty (using formula 5.3) is:

$$\sqrt{\frac{(0,1V)^2}{3} \times ((10\%/V)^2 + (3\%/V)^2)} = 0,60 \%$$

This is then transformed to logarithmic form:  $0,60/23,0 \text{ \%} = 0,03 \text{ dB}$  (ETR 028 [15], part 2, annex E).

The standard uncertainty of the contribution, due to the influence of setting the power supply on the spurious emission level, is designated throughout all parts of ETR 273 [15] as  $u_{j54}$ .

NOTE 1: In this example case the standard uncertainty of the contribution, due to the influence of setting the power supply on the spurious emission level, is calculated above as 0,03 dB.

**EUT: influence of the ambient temperature on the spurious emissions:** This is the uncertainty in the power level of the spurious emission caused by the uncertainty in knowing the ambient temperature. The ambient temperature uncertainty is  $\pm 1^\circ\text{C}$ . The uncertainty caused by this temperature uncertainty is calculated using the dependency function (ETR 028 [15], part 2, annex C, table C.1: "EUT dependency functions and uncertainties") whose mean value is  $4\ \%/^\circ\text{C}$  and whose standard uncertainty is  $1,2\ \%/^\circ\text{C}$ . The standard uncertainty of the spurious emission power level uncertainty caused by ambient temperature uncertainty (using formula 5.3) is:

$$\sqrt{\left(\frac{(1^\circ\text{C})^2}{3}\right) \times ((4,0\%/^\circ\text{C})^2 + (1,2\%/^\circ\text{C})^2)} = 2,41\ \%$$

This is then transformed to logarithmic form:  $2,41/23,0\ \% = 0,10\ \text{dB}$  (ETR 028 [15]: part 2: annex E).

The standard uncertainty of the contribution, due to the influence of the ambient temperature on the spurious emissions, is designated throughout all parts of ETR 273 [12] as  $u_{j51}$ .

NOTE 2: In this example case the standard uncertainty of the contribution due to the influence of the ambient temperature on the spurious emissions level is calculated above as 0,10 dB.

**EUT: mutual coupling to the power leads:** This is the uncertainty associated with the influence (reflections, parasitic effects, etc.) of the power leads on the EUT. The standard uncertainty associated with this effect is 0,5 dB provided that the precautions detailed in the methods have been observed. I.e. routing and dressing of cables with ferrites. If no prevention has been attempted the standard uncertainty is 2,0 dB. The standard uncertainty of the contribution, due to the mutual coupling to the power leads, is designated throughout all parts of ETR 273 [12] as  $u_{j54}$ .

NOTE 3: In this example case the standard uncertainty of the contribution due to the mutual coupling to the power leads is taken as 0,5 dB since the precautions detailed in the methods are assumed to have been observed.

**Position of the phase centre: within the EUT volume:** This contribution is associated with the uncertainty with which the actual radiating point within the equipment volume is known. If this point is known exactly the contribution is 0,00 dB. The standard uncertainty of the contribution, due to the position of the phase centre within the EUT volume, is designated throughout all parts of ETR 273 [12] as  $u_{j20}$ .

NOTE 4: In this example case the standard uncertainty of the contribution due to the position of the phase centre within the EUT volume has been calculated from  $(\pm(\text{the maximum dimension of device})/(2 \times \text{range length}) \times 100\ \%)$ . In this example the position is not known. Hence, the uncertainty of the position of the phase centre within the EUT of 0,15 m maximum dimension is  $0,15/2\ \text{m} = 0,075\ \text{m}$ , and the worst case uncertainty due to this offset is therefore  $\pm(0,075/3,0) \times 100\ \% = \pm 2,50\ \%$ . As the phase centre can be anywhere inside the EUT, the uncertainty is taken as rectangularly distributed and the standard uncertainty is calculated as 1,44 %. This is then transformed to the logarithmic form  $(1,44/11,5) = 0,12\ \text{dB}$  (ETR 028 [15]: part 2: annex E).

**Positioning of the phase centre: within the EUT over the axis of rotation of the turntable:** This contribution is associated with the uncertainty with which the actual radiating point within the equipment is placed over the centre of the turntable. If the point is placed exactly, the contribution is 0,00 dB. The standard uncertainty of the contribution due to the positioning of the EUT phase centre over the axis of rotation of the turntable, is designated throughout all parts of ETR 273 [12] as  $u_{j21}$ .

NOTE 5: In this example case the standard uncertainty of the contribution due to the positioning of the EUT phase centre over the axis of rotation of the turntable is calculated from  $(\pm(\text{the estimated offset from the axis of rotation})/(2 \times \text{range length}) \times 100\ \%)$ . In this case, the uncertainty of the positioning is taken as  $\pm 0,01\ \text{m}$ , and the worst case uncertainty is  $\pm(0,01/3,0) \times 100 = \pm 0,333\ \%$ . As the offset can be anywhere between the limits the uncertainty is rectangularly distributed and the standard uncertainty is calculated as 0,192 %. This is then transformed to the logarithmic form  $(0,192/11,5) = 0,02\ \text{dB}$  (ETR 028 [15]: part 2: annex E).

**Range length:** This contribution is associated with the curvature of the phase front from the EUT to the test antenna. The standard uncertainty of the contribution due to the range length is designated throughout all parts of ETR 273 [12] as  $u_{j16}$ . The standard uncertainty of the contribution should be obtained from table 14.

**Table 14: Uncertainty contribution of the range length (verification)**

Range length (i.e. the horizontal distance between phase centres)	Standard uncertainty of the contribution
$(d_1+d_2)^2/4\lambda \leq \text{range length} < (d_1+d_2)^2/2\lambda$	1,26 dB
$(d_1+d_2)^2/2\lambda \leq \text{range length} < (d_1+d_2)^2/\lambda$	0,30 dB
$(d_1+d_2)^2/\lambda \leq \text{range length} < 2(d_1+d_2)^2/\lambda$	0,10 dB
$\text{range length} \geq 2(d_1+d_2)^2/\lambda$	0,00 dB

NOTE 6: In table 14,  $d_1$  and  $d_2$  are the maximum dimensions of the antennas.

NOTE 7: In this example case the standard uncertainty of the contribution due to the range length is taken as 0,00 dB since the range length is  $\geq 2(d_1+d_2)^2/\lambda$ .

#### 6.8.3.1.2.2 Site factors

**Ambient effect:** Ambient effect is the uncertainty caused by local ambient signals raising the noise floor at the measurement frequency. The standard uncertainty of the contribution, due to the ambient effect, is designated throughout all parts of ETR 273 [12] as  $u_{j34}$ . The values of the standard uncertainty should be taken from table 15.

**Table 15: Uncertainty contribution: Ambient effect**

Receiving device noise floor (EUT OFF) is within:	Standard uncertainty of the contribution
3 dB of measurement	1,57 dB
3 dB to 6 dB of measurement	0,80 dB
6 dB to 10 dB of measurement	0,30 dB
10 dB to 20 dB of measurement	0,10 dB
20 dB or more of the measurement	0,00 dB

NOTE 1: In this example case the standard uncertainty of the contribution due to the ambient effect is taken as 0,00 dB, since the chamber is assumed to be shielded.

**Mutual coupling: amplitude effect of the test antenna on the EUT:** This uncertainty results from the interaction between the EUT and the test antenna when placed close together. The standard uncertainty of the contribution due to the amplitude effect of the mutual coupling between the test antenna and the EUT, is designated throughout all parts of ETR 273 [12] as  $u_{j08}$ . The standard uncertainty should be taken from table 16.

**Table 16: Uncertainty contribution: Mutual coupling: amplitude effect of the test antenna on the EUT**

Range length	Standard uncertainty of the contribution
$0,62\sqrt{((d_1+d_2)^3/\lambda)} \leq \text{range length} < 2(d_1+d_2)^2/\lambda$	0,50 dB
$\text{range length} \geq 2(d_1+d_2)^2/\lambda$	0,00 dB

NOTE 2: In this example case the standard uncertainty of the contribution due to the amplitude effect of the mutual coupling between the test antenna and the EUT is 0,00 dB since the distance is  $\geq 2(d_1+d_2)^2/\lambda$ .

**Mutual coupling: EUT to its images in the absorbing material:** This uncertainty is dependant on the quality of the absorbing material and the effect imaging of the EUT in the ceiling, side and end walls has on the input impedance and/or gain of the integral antenna. The standard uncertainty of the contribution, due to the mutual coupling of the EUT to its images in the absorbing material, is designated throughout all parts of ETR 273 [12] as  $u_{j04}$ .

NOTE 3: In this example case the standard uncertainty of the contribution due to the mutual coupling amplitude effect of the absorbing material on the EUT is assumed to be 0,5 dB (see annex A).

**Mutual coupling: EUT to its image in the ground plane:** This uncertainty results from the change in the EUT spurious emission level as a result of being placed close to the ground plane. The standard uncertainty of the contribution, due to the mutual coupling of the EUT to its image in the ground plane, is designated throughout all parts of ETR 273 [12] as  $u_{j13}$ . Its value can be obtained from table 17.

**Table 17: Uncertainty contribution of the mutual coupling between the EUT to its image in the ground plane**

Spacing between the EUT and the ground plane	Standard uncertainty of the contribution
<b>For a vertically polarized EUT</b>	
spacing $\leq 1,25 \lambda$	0,15 dB
spacing $> 1,25 \lambda$	0,06 dB
<b>For a horizontally polarized EUT</b>	
spacing $< \lambda/2$	1,15 dB
$\lambda/2 \leq$ spacing $< 3\lambda/2$	0,58 dB
$3\lambda/2 \leq$ spacing $< 3\lambda$	0,29 dB
spacing $\geq 3\lambda$	0,15 dB

NOTE 4: In this example case the standard uncertainty of the contribution, due to the mutual coupling of the EUT to its image in the ground plane (assuming the polarization is vertical and the spacing above the ground plane is  $< 1,25 \lambda$  at the test frequency), is taken as 0,15 dB.

**Reflectivity of absorbing material: EUT to the test antenna.** This uncertainty is associated with the magnitudes of the reflections occurring from the side walls, end walls and ceiling. These magnitudes are a function of the quality of the absorber at the frequency of test. The standard uncertainty of the contribution, due to the reflectivity of the absorbing material between the EUT and the test antenna, is designated throughout all parts of ETR 273 [12] as  $u_{j01}$ . The relevant value for this contribution should be taken from table 18.

**Table 18: Uncertainty contribution of the reflectivity of absorbing material between the EUT and test antenna**

Reflectivity of the absorbing material	Standard uncertainty of the contribution
reflectivity $< 10$ dB	4,76 dB
$10 \leq$ reflectivity $< 15$ dB	3,92 dB
$15 \leq$ reflectivity $< 20$ dB	2,56 dB
$20 \leq$ reflectivity $< 30$ dB	1,24 dB
reflectivity $\geq 30$ dB	0,74 dB

NOTE 5: In this example case the standard uncertainty of the contribution due to the reflectivity of the absorbing material between the EUT and the test antenna is taken as 0,00 dB since this is a substitution measurement and the contribution cancels (see annex A).

**Mutual coupling: test antenna to its images in the absorbing material:** This is the uncertainty due to the mutual coupling between the test antenna and its images in the ceiling, side and end walls and is the effect of the change produced in the antenna's input impedance and/or gain. As this is the first stage of a substitution measurement and the uncertainty is common to both stages it will only contribute in the second stage if the test antenna is located at a different height on the antenna mast. The standard uncertainty of the contribution, due to the mutual coupling between the test antenna and its images in the absorbing material, is designated throughout all parts of ETR 273 [12] as  $u_{j06}$ .

NOTE 6: In this example case the standard uncertainty of the contribution due to the mutual coupling between the test antenna and its images in the absorbing material is taken as 0,00 dB since this is the reference position.

**Mutual coupling: test antenna to its image in the ground plane:** This is the uncertainty due to the mutual coupling between the test antenna and its image in the ground plane and is the effect of the change produced in the antenna's input impedance and/or gain when placed close to a ground plane. As this is the first stage of a substitution measurement and the uncertainty is common to both stages, it will only contribute in the second stage if the test antenna is located at a different height on the antenna mast. The standard uncertainty of the contribution, due to the mutual coupling between the test antenna and its image in the ground plane, is designated throughout all parts of ETR 273 [12] as  $u_{j14}$ .

NOTE 7: In this example case the standard uncertainty of the contribution due to the mutual coupling between the test antenna and its image in the ground plane is taken as 0,00 dB since this is the reference position.

#### 6.8.3.1.2.3 Test antenna

**Correction: measurement distance:** For those tests in which the test antenna on the mast peaks at different heights in the two stages, a correction for the measurement distance should be made to account for the different measurement distances. The standard uncertainty of the contribution due to the correction for measurement distance is designated throughout all parts of ETR 273 [12] as  $u_{j18}$ .

NOTE 1: In this example case the standard uncertainty of the contribution due to the correction for measurement distance is taken as 0,00 dB since, in this, the first stage of the measurement, only a reference height is being set.

**Correction: off boresight angle in elevation plane:** For those tests in which the test antenna on the mast peaks at different heights in the two stages, a correction must be made to account for the different angles subtended by the EUT/substitution antenna. The standard uncertainty of the contribution, due to the correction for off boresight angle in elevation plane, is designated throughout all parts of ETR 273 [12] as  $u_{j17}$ .

NOTE 2: In this example case the standard uncertainty of the contribution due to the correction for off boresight angle in elevation plane is taken as 0,00 dB since in this, the first stage of the measurement, only a reference height is being set.

**Antenna: gain of the test antenna:** The gain, and its uncertainty, of the test antenna act as systematic offsets since they are present in both stages of the test. The standard uncertainty of the contribution, due to the uncertainty of the gain of the test antenna, is designated throughout all parts of ETR 273 [12] as  $u_{j45}$ .

NOTE 3: In this example case the standard uncertainty of the contribution due to the uncertainty of the gain of the test antenna is taken as 0,00 dB since the uncertainty is systematic i.e. it produces the same offset in both stages.

**Antenna: tuning of the test antenna:** This uncertainty is introduced as a result of inaccurate tuning of the test antenna. The standard uncertainty of the contribution, due to the tuning of the test antenna, is designated throughout all parts of ETR 273 [12] as  $u_{j46}$ .

NOTE 4: In this example case the standard uncertainty of the contribution due to the tuning of the test antenna is taken as 0,00 dB since the uncertainty is systematic i.e. it is assumed constant and common to both stages of the measurement and, provided that once set in stage one of the test it is not subsequently re-tuned, its contribution is the same in both stages.

**Position of the phase centre: test antenna:** The horizontal position of the test antenna defines one end of the range length. The standard uncertainty of the contribution, due to the position of the phase centre of the test antenna, is designated throughout all parts of ETR 273 [12] as  $u_{j22}$ .

NOTE 5: In this example case the test antenna is assumed to describe a vertical straight line as its height on the mast is changed. The standard uncertainty of the contribution due to the position of the phase centre of the test antenna is assumed to be 0,00 dB (see annex A).

#### 6.8.3.1.2.4 Test antenna attenuator

**Insertion loss: test antenna attenuator:** The attenuator has an insertion loss as well as an uncertainty associated with the measurement of its magnitude. The value of insertion loss and its uncertainty remain valid provided the attenuator is not used outside the manufacturer's specification. At any given frequency the insertion loss acts as a systematic offset and contributes equally to both stages of the measurement. The standard uncertainty of the contribution due to the insertion loss of the test antenna attenuator is designated throughout all parts of ETR 273 [12] as  $u_{j40}$ .

NOTE: In this example case the standard uncertainty of the contribution, due to the insertion loss uncertainty of the test antenna attenuator, is taken as 0,00 dB since the uncertainty is systematic i.e. it produces the same offset in both stages.

### 6.8.3.1.2.5 Test antenna cable

**Insertion loss: test antenna cable:** The test antenna cable has an insertion loss as well as an uncertainty associated with the measurement of its magnitude. The value of insertion loss and its uncertainty remain valid provided the cable is not used outside the manufacturer's specification. At any given frequency the insertion loss acts as a systematic offset and contributes equally to both stages of the measurement. The standard uncertainty of the contribution, due to the insertion loss uncertainty of the test antenna cable, is designated throughout all parts of ETR 273 [12] as  $u_{j41}$ .

NOTE 1: In this example case the standard uncertainty of the contribution due to the insertion loss uncertainty of the test antenna cable is taken as 0,00 dB since the uncertainty is systematic i.e. it produces the same offset in both stages.

**Cable factor: test antenna cable:** Cable factor is defined as the total effect of the antenna cable's influence on the measuring system including its interaction with the site. It consists of the leakage caused by cable screening inefficiency, parasitic effects (acting as a director or reflector) on the test antenna and introducing an unbalanced, common mode current into the dipole balun. In a radiated measurement the standard uncertainty of the cable factor, associated with each cable, is 0,5 dB provided that the precautions detailed in the methods have been observed. i.e. routing and dressing of cables with ferrites. If no prevention has been attempted the standard uncertainty is 4,0 dB (justification for these values is given in ETR 273 [12], part 1, subpart 2, annex E). The standard uncertainty of the contribution due to the cable factor of the test antenna cable is designated throughout all parts of ETR 273 [12] as  $u_{j19}$ .

NOTE 2: In this example case the standard uncertainty of the contribution due to the cable factor of the test antenna cable is taken as 0,50 dB since in this measurement, the cable changes position in both stages (the height of the test antenna being optimized in both stages) even though the precautions detailed in the methods have been observed.

### 6.8.3.1.2.6 Receiving device

Whereas the first stage of a spurious emission test is to observe and record the received level from the EUT on the receiving device, the second stage involves the adjustment of the output level of a signal generator to achieve the same received level from a substitution antenna. As a consequence of this methodology, the receiving device contributes neither linearity nor absolute level uncertainty to either stage of the test.

**Receiving device: absolute level:** The standard uncertainty of the contribution, due to the absolute level uncertainty of the receiving device, is designated throughout all parts of ETR 273 [12] as  $u_{j47}$ .

NOTE 1: In this example case the standard uncertainty of the contribution, due to the absolute level uncertainty of the receiving device is taken as 0,00 dB.

**Receiving device: linearity:** The standard uncertainty of the contribution, due to the receiving device linearity, is designated throughout all parts of ETR 273 [12] as  $u_{j48}$ .

NOTE 2: In this example case the standard uncertainty of the contribution due to the receiving device linearity is taken as 0,00 dB.

### 6.8.3.1.3 Contribution from the random component

**Random uncertainty:** The magnitude can be assessed from multiple measurements of the spurious emission. The standard uncertainty of the contribution due to the random uncertainty is designated throughout all parts of ETR 273 [12] as  $u_{j01}$ .

The EUT measurement was repeated 10 times. The following results were obtained in dB $\mu$ V (before correcting for cabling and attenuator network insertion loss):

- 65,4; 63,4; 66,0; 65,3; 63,0; 64,9; 65,2; 66,8; 65,5; 63,7.

Converting to linear terms:

-  $1,862 \times 10^{-3}$ ;  $1,479 \times 10^{-3}$ ;  $1,995 \times 10^{-3}$ ;  $1,841 \times 10^{-3}$ ;  $1,413 \times 10^{-3}$ ;  $1,758 \times 10^{-3}$ ;  $1,820 \times 10^{-3}$ ;  $2,188 \times 10^{-3}$ ;  $1,884 \times 10^{-3}$ ;  $1,531 \times 10^{-3}$ .



The two sums  $X$  and  $Y$  are calculated:

- $X =$  the sum of the measured values  $= 17,77 \times 10^{-3}$ ;
- $Y =$  the sum of the squares of the measured values  $= 32,10 \times 10^{-6} \text{ V}^2$ .

$$u_{c \text{ random}} = \sqrt{\frac{Y - \frac{X^2}{n}}{n-1}} = \sqrt{\frac{32,10 \times 10^{-6} - \frac{(17,77 \times 10^{-3})^2}{10}}{10-1}} = 238,3 \times 10^{-6} \text{ (formula 5.6)}$$

As the result is obtained as the mean value of 10 measurements and the standard uncertainty of the random uncertainty is:

$$u_{j \text{ random}} = \frac{238,3 \times 10^{-6}}{1,777 \times 10^{-3}} \times \frac{100}{11,5} = 1,17 \text{ dB}$$

NOTE: In this example case the standard uncertainty of the contribution due to the random uncertainty is 1,17 dB.

#### 6.8.3.1.4 Summary table of contributory components

All the uncertainty contributions for this part of the procedure are listed in table 19.

**Table 19: Contributions from the EUT measurement**

$u_j$ or $i$	Description of uncertainty contributions	dB
$u_{j37}$	mismatch: receiving part	0,00
$u_{j54}$	EUT: influence of setting the power supply on the spurious emission level	0,03
$u_{j51}$	EUT: influence of the ambient temperature on the spurious emission level	0,03
$u_{j55}$	EUT: mutual coupling to the power leads	0,50
$u_{j20}$	position of the phase centre: within the EUT volume	0,12
$u_{j21}$	positioning of the phase centre: within the EUT over the axis of rotation of the turntable	0,02
$u_{j16}$	range length	0,00
$u_{j34}$	ambient effect	0,00
$u_{j08}$	mutual coupling: amplitude effect of the test antenna on the EUT	0,00
$u_{j04}$	Mutual coupling: EUT to its images in the absorbing material	0,50
$u_{j13}$	mutual coupling: EUT to its image in the ground plane	0,15
$u_{j01}$	reflectivity of absorbing material: EUT to the test antenna	0,00
$u_{j06}$	mutual coupling: test antenna to its images in the absorbing material	0,00
$u_{j14}$	mutual coupling: test antenna to its image in the ground plane	0,00
$u_{j18}$	correction: measurement distance	0,00
$u_{j17}$	correction: off boresight angle in elevation plane	0,00
$u_{j45}$	antenna: gain of the test antenna	0,00
$u_{j46}$	antenna: tuning of the test antenna	0,00
$u_{j22}$	position of the phase centre: test antenna	0,00
$u_{j40}$	insertion loss: test antenna attenuator	0,00
$u_{j41}$	insertion loss: test antenna cable	0,00
$u_{j19}$	cable factor: test antenna cable	0,50
$u_{j47}$	receiving device: absolute level	0,00
$u_{j48}$	receiving device: linearity	0,00
$u_{i01}$	random uncertainty	1,17

The standard uncertainties from table 19 should be combined by RSS in accordance with ETR 273 [12], part 1, subpart 1, clause 5. This gives the combined standard uncertainty ( $u_{c \text{ contribution from the EUT measurement}}$ ) for the EUT measurement in dB.

The value of  $u_{c \text{ contribution from the EUT measurement}}$  is calculated as 1,47 dB.

### 6.8.3.2 Uncertainty contributions: Stage 2: Substitution measurement

The second stage of the spurious emission test (the substitution) involves replacing the EUT with a substitution antenna and signal source as shown in figure 27, and adjusting the output level of the signal generator until the same level as in stage one is achieved on the receiving device.

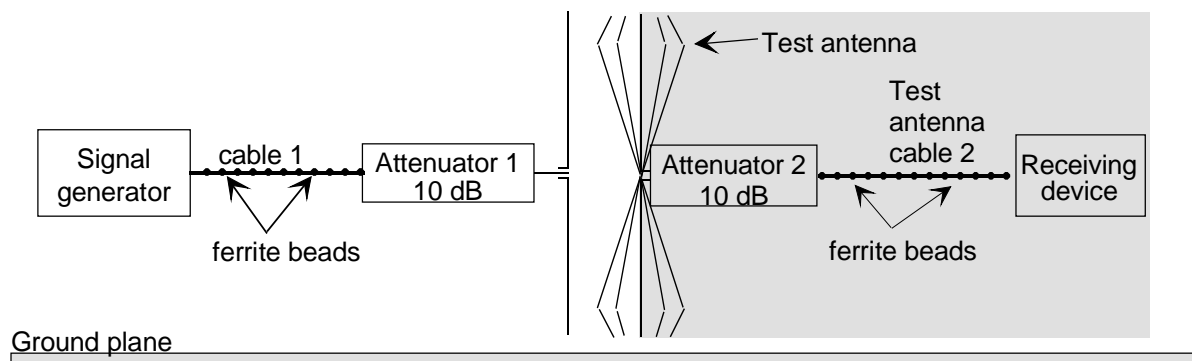

Figure 27: Stage two: Typical emission substitution test

Whereas figure 27 shows, schematically, the test equipment set-up for this substitution stage of the spurious emission test, figure 28, an analysis diagram, provides a detailed picture of the individual uncertainty components (each of which contributes its own uncertainty) for this stage in the measurement. As stated above, the shaded areas represent components common to both stages of the test method.

#### 6.8.3.2.1 Contributions from the mismatch components

**Mismatch uncertainty transmitting and receiving parts:** The value of the combined standard uncertainty of the contribution due to the mismatch for the substitution measurement are calculated from the approach described in annex G. For this stage it is calculated in two parts. Firstly the standard uncertainty of the contribution due to the mismatch in the transmitting part, i.e. between the signal generator, cable, attenuator and the substitution antenna and secondly, that for the receiving part, i.e. between the test antenna, attenuator, cable and the receiver. However, only the contribution for the transmitting part is actually calculated since the receiving part is common to both stages of the test and its uncertainty contribution therefore largely cancels.

##### Mismatch: transmitting part:

Signal generator:	Output reflection coefficient: $ \rho_G $	= 0,20
Cable:	Input and output reflection coefficients: $ S_{11} $ and $ S_{22} $	= 0,07
	Attenuation: 1 dB = $ S_{12}  =  S_{21} $	= 0,891
Attenuator:	Input and output reflection coefficients $ S_{11}  =  S_{22} $	= 0,05
	Attenuation = 10 dB $ S_{12}  =  S_{21} $	= 0,3162
Transmitting antenna:	Input reflection coefficient: $ \rho_{TA} $	= 0,333

All these contributions are U-distributed. Those components that cancel are not calculated. Other contributions are (see annex G):

- $u_{j \text{ generator and cable } i}$ : Constant for both stage 1 and 2. Hence this value does not contribute.
- $u_{j \text{ cable 1 and attenuator } i}$ : Constant for both stage 1 and 2. Hence this value does not contribute.

$$u_{j \text{ attenuator 1 and antenna}} = \frac{0,05 \times 0,333 \times 100}{\sqrt{2}} \% = 1,177 \%$$

- $u_{j \text{ generator and attenuator } 1}$ : Constant for both stage 1 and 2. Hence this value does not contribute.

$$u_{j \text{ cable and antenna}} = \frac{0,07 \times 0,333 \times 0,316^2 \times 100}{\sqrt{2}} \% = 0,165\%$$

$$u_{j \text{ generator and antenna}} = \frac{0,2 \times 0,333 \times 0,891^2 \times 0,316^2 \times 100}{\sqrt{2}} \% = 0,373\%$$

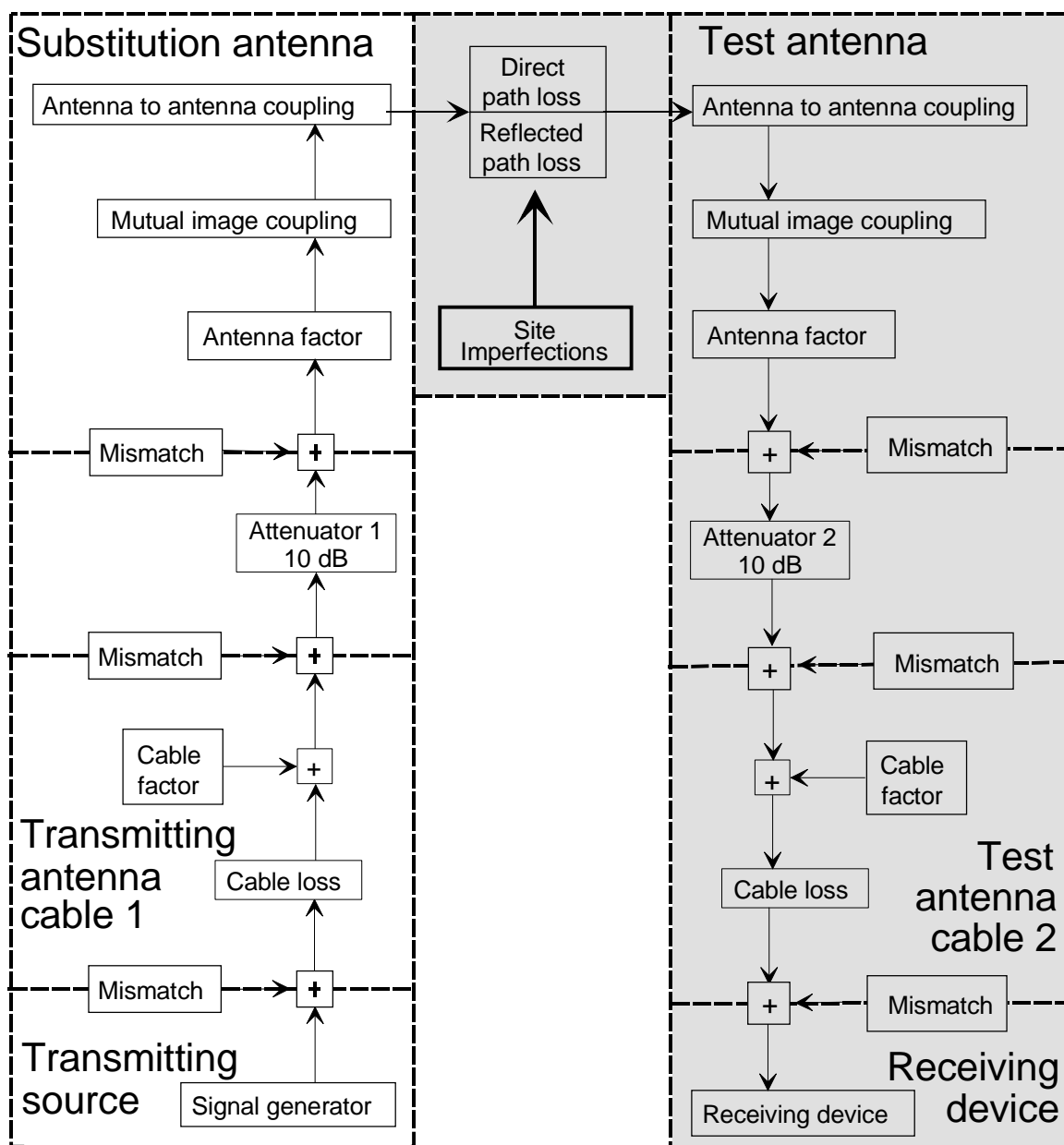

Figure 28: Stage two: Substitution measurement individual uncertainty components

The combined standard uncertainty of the mismatch is then calculated:

$$u_{\text{mismatch:substitution}} = \sqrt{1,177^2 + 0,165^2 + 0,373^2} = 1,25\%$$

Transforming to the logarithmic form (ETR 028 [15], part 2, annex E):  $1,24 \% / 11,5 = 0,11 \text{ dB}$ .

The standard uncertainty of the contribution due to the mismatch in the transmitting part, is designated throughout all parts of ETR 273 [12] as  $u_{36}$ . Its value in this example is 0,11 dB.

**Mismatch: Receiving part:**

The mismatch uncertainty between the test antenna and the receiving device contributes equally to both stages of the test and therefore has no contribution to the combined standard uncertainty. Therefore it is not calculated. The standard uncertainty of the contribution due to mismatch in the receiving part is designated throughout all parts of ETR 273 [12] as  $u_{j37}$ .

NOTE 4: In this example case the standard uncertainty of the contribution due to mismatch in the receiving part is taken as 0,00 dB since the uncertainty is systematic i.e. it produces the same offset in both stages.

### 6.8.3.2.2 Contributions from the individual components

#### 6.8.3.2.2.1 Signal generator

**Signal generator: absolute output level:** The signal generator replaces the EUT in the substitution part of this test and, as a result, should be included in the combined standard uncertainty since it does not cancel as a systematic offset. The standard uncertainty of the contribution, due to the signal generator absolute output level, is designated throughout all parts of ETR 273 [12] as  $u_{j38}$ .

NOTE 1: In this example case the uncertainty of the contribution due to the signal generator absolute output level uncertainty is obtained from the manufacturers data sheet as  $\pm 1,0$  dB. As nothing is said about the distribution of this uncertainty, a rectangular distribution (see ETR 273 [12], part 1, subpart 1, clause 5.1.2) in logs is assumed, and the standard uncertainty is calculated as 0,58 dB.

**Signal generator: output level stability:** In any test in which the contribution of the absolute level uncertainty of the signal generator contributes to the combined standard uncertainty of the test i.e. it does not cancel due to the methodology, the contribution from the output level stability is considered to have been included in the signal generator absolute output level,  $u_{j38}$ . Conversely, for any level in which the absolute level uncertainty of the signal generator does not contribute to the combined standard uncertainty, the output level stability of the signal generator should be included. The standard uncertainty of the contribution due to the signal generator output level stability is designated throughout all parts of ETR 273 [12] as  $u_{j39}$ . Its value can be derived from manufacturers' data sheet.

NOTE 2: In this example case the standard uncertainty of the contribution due to the signal generator output level stability is taken as 0,00 dB as it is covered by the absolute level uncertainty.

#### 6.8.3.2.2.2 Substitution antenna cable

**Insertion loss: substitution antenna cable:** The substitution antenna cable has an insertion loss as well as an uncertainty associated with the measurement of its magnitude. The value of insertion loss and its uncertainty remain valid provided the cable is not used outside the manufacturer's specification. At any given frequency the insertion loss acts as a systematic offset and contributes equally to both stages of the measurement. The standard uncertainty of the contribution due to the insertion loss uncertainty of the substitution antenna cable, is designated throughout all parts of ETR 273 [12] as  $u_{j41}$ .

NOTE 1: In this example case the uncertainty of the contribution due to the insertion loss uncertainty of the substitution antenna cable is taken from the manufacturers data sheet as  $\pm 0,5$  dB. As nothing is said about the distribution, a rectangular distribution (see ETR 273 [12], part 1, subpart 1, clause 5.1.2) in logs is assumed and the standard uncertainty is calculated as 0,29 dB.

**Cable factor: substitution antenna cable:** Cable factor is defined as the total effect of the antenna cable's influence on the measuring system including its interaction with the site. It consists of the leakage caused by cable screening inefficiency, parasitic effects (acting as a director or reflector) and introducing an unbalanced, common mode current into the dipole balun. In a radiated measurement the standard uncertainty of the cable factor, associated with the substitution antenna cable is 0,5 dB provided the precautions detailed in the methods have been observed. i.e. routing and dressing of cables with ferrites. If no prevention has been attempted the standard uncertainty is 4,0 dB (justification for these values is given in ETR 273 [12], part 1, subpart 2, annex E). The standard uncertainty of the contribution, due to the cable factor of the substitution antenna cable, is designated throughout all parts of ETR 273 [12] as  $u_{j19}$ .

NOTE 2: In this example case the standard uncertainty of the contribution due to the cable factor of the substitution antenna cable is taken as 0,50 dB since the precautions detailed in the methods are assumed to have been observed.

### 6.8.3.2.2.3 Substitution antenna attenuator

**Insertion loss: substitution antenna attenuator:** The attenuator has an insertion loss as well as an uncertainty associated with the measurement of its magnitude. The value of insertion loss and its uncertainty remain valid provided the attenuator is not used outside the manufacturer's specification. At any given frequency the insertion loss is taken from the manufacturer's data sheet since it does not cancel as a systematic offset (it only appears in one stage of the test). The standard uncertainty of the contribution, due to the insertion loss uncertainty of the substitution antenna attenuator, is designated throughout all parts of ETR 273 [12] as  $u_{j40}$ .

NOTE : In this example case the uncertainty of the contribution, due to the insertion loss uncertainty of the substitution antenna attenuator, is obtained from the manufacturer's data sheet as  $\pm 0,3$  dB. As nothing is said about the distribution, a rectangular distribution (see ETR 273 [12], part 1, subpart 1, clause 5.1.2) in logs is assumed and the standard uncertainty is calculated as 0,17 dB.

### 6.8.3.2.2.4 Substitution antenna

**Antenna: gain of the substitution antenna:** The gain (and its uncertainty) of the substitution antenna is only involved in the second stage of the test. The standard uncertainty of the contribution due to the gain of the substitution antenna is designated throughout all parts of ETR 273 [12] as  $u_{j45}$ . For ANSI dipoles the value should be obtained from table 20.

**Table 20: Uncertainty contribution: Antenna: gain of the test or substitution antenna**

Frequency	Standard uncertainty of the contribution
30 MHz $\leq$ frequency $\leq$ 80 MHz	1,73 dB
80 MHz < frequency $\leq$ 180 MHz	0,60 dB
frequency > 180 MHz	0,30 dB

NOTE 1: For other antenna types the figures should be taken from manufacturers data sheets. If a figure is not given the standard uncertainty is 1,0 dB.

NOTE 2: In this example case the standard uncertainty of the contribution due to the gain of the substitution antenna is taken as 0,3 dB as an ANSI dipole is used and the frequency is above 180 MHz.

**Antenna: tuning of the substitution antenna:** Uncertainty is introduced as a result of the inaccurate tuning of the substitution antenna. This only occurs in stage two of the measurement. The standard uncertainty of the contribution, due to the tuning of the substitution antenna, is designated throughout all parts of ETR 273 [12] as  $u_{j46}$ .

NOTE 3: In this example case the standard uncertainty of the contribution due to the tuning of the substitution antenna is taken as 0,06 dB.

**Position of the phase centre: substitution antenna:** Uncertainty is introduced as a result of the inaccurate positioning of the phase centre of the substitution antenna. This only occurs in stage two of the measurement. The standard uncertainty of the contribution, due to the position of the phase centre of the substitution antenna, is designated throughout all parts of ETR 273 [12] as  $u_{j22}$ .

NOTE 4: In this example case the standard uncertainty of the contribution due to the uncertainty in the position of the phase centre of the substitution antenna has been calculated from  $(\pm(\text{the offset from axis of rotation})/(\text{range length}) \times 100 \%)$ . The positioning uncertainty is  $\pm 0,01$  m and therefore the worst case uncertainty =  $0,01/3,0 = 0,333 \%$ . As the offset can be anywhere between these limits, the uncertainty is taken to be rectangularly distributed (see ETR 273 [12], part 1, subpart 1, clause 5.1.2) and the standard uncertainty is calculated as 0,192 %. This is transformed to the logarithmic form (ETR 028 [15], part 2, annex E), to be 0,02 dB.

## 6.8.3.2.2.5 Site factors

**Ambient effect:** Uncertainty is introduced as a result of local ambient signals raising the noise floor at the measurement frequency. The standard uncertainty of the contribution due to the ambient effect is designated throughout all parts of ETR 273 [12] as  $u_{j34}$ . The values of the standard uncertainty should be taken from table 21.

**Table 21: Uncertainty contribution: Ambient effect**

Receiving device noise floor (generator OFF) is within:	Standard uncertainty of the contribution
3 dB of measurement	1,57 dB
3 dB to 6 dB of measurement	0,80 dB
6 dB to 10 dB of measurement	0,30 dB
10 dB to 20 dB of measurement	0,10 dB
20 dB or more of the measurement	0,00 dB

NOTE 1: In this example case the standard uncertainty of the contribution due to the ambient effect is taken as 0,00 dB, since the chamber is assumed to be shielded.

**Mutual coupling: substitution antenna to its images in the absorbing material:** This uncertainty is the effect of the change produced in the antenna's input impedance and/or gain. The standard uncertainty of the contribution due to the mutual coupling of the substitution antenna to its images in the absorbing material is designated throughout all parts of ETR 273 [12] as  $u_{j06}$ .

NOTE 2: In this example case the standard uncertainty of the contribution due to the mutual coupling of the transmitting antenna to its images in the absorbing materials is taken as 0,5 dB (see annex A).

**Mutual coupling: substitution antenna to its image in the ground plane:** This uncertainty is the effect of the change produced in the antenna's input impedance and/or gain. The standard uncertainty of the contribution due to the mutual coupling of the substitution antenna to its image in the ground plane, designated throughout all parts of ETR 273 [12] as  $u_{j14}$ . has a value of 0,00 dB for ANSI dipoles since it is included, where significant, in the mutual coupling and mismatch loss correction factors (see table A.20). For other dipoles the value can be obtained from table 22.

**Table 22: Uncertainty contribution of the mutual coupling between the substitution antenna and its image in the ground plane**

Spacing between the antenna and the ground plane	Standard uncertainty of the contribution
<b>For a vertically polarized antenna</b>	
spacing $\leq 1,25 \lambda$	0,15 dB
spacing $> 1,25 \lambda$	0,06 dB
<b>For a horizontally polarized antenna</b>	
spacing $< \lambda/2$	1,15 dB
$\lambda/2 \leq$ spacing $< 3\lambda/2$	0,58 dB
$3\lambda/2 \leq$ spacing $< 3\lambda$	0,29 dB
spacing $\geq 3\lambda$	0,15 dB

NOTE 3: In this example case the standard uncertainty of the contribution due to mutual coupling between the substitution antenna and its image in the ground plane is taken as 0,58 dB.

**Mutual coupling: substitution antenna to the test antenna:** This is the effect produced by any change in gain of the antennas which results from their close spacing. The standard uncertainty of the contribution due to the mutual coupling of the substitution antenna to the test antenna, designated throughout all parts of ETR 273 [12] as  $u_{j11}$ . For ANSI dipoles the value of this uncertainty is 0,00 dB as it is included, where significant, in the mutual coupling and mismatch loss correction factors. For non-ANSI dipoles the standard uncertainty for frequencies can be taken from table 23.

**Table 23: Uncertainty contribution of the mutual coupling between the substitution and test antennas**

Frequency	Standard uncertainty of the contribution (3 m range)	Standard uncertainty of the contribution (10 m range)
30 MHz ≤ frequency < 80 MHz	1,73 dB	0,60 dB
80 MHz ≤ frequency < 180 MHz	0,6 dB	0,00 dB
frequency ≥ 180 MHz	0,00 dB	0,00 dB

NOTE 4: In this example case the standard uncertainty of the contribution due to mutual coupling between the substitution and test antennas is taken as 0,00 dB as the frequency is above 180 MHz.

**Mutual coupling: interpolation of mutual coupling and mismatch loss correction factors, only for ANSI dipoles:**

The standard uncertainty of the contribution due to the interpolation of mutual coupling and mismatch loss correction factors, is designated throughout all parts of ETR 273 [12] as  $u_{j12}$ . For spot frequencies given in table A.20, the value of the contribution is 0,00 dB. However, for all other frequencies, the standard uncertainty should be obtained from table 24.

**Table 24: Uncertainty contribution of the interpolation of mutual coupling and mismatch loss correction factors**

Frequency (MHz)	Standard uncertainty of the contribution
for a spot frequency given in the table	0,00 dB
30 MHz ≤ frequency < 80 MHz	0,58 dB
80 MHz ≤ frequency < 180 MHz	0,17 dB
frequency ≥ 180 MHz	0,00 dB

NOTE 5: In this example case the standard uncertainty of the contribution due to the interpolation of mutual coupling and mismatch loss correction factors is taken as 0,00 dB as the frequency is above 180 MHz.

**Range length:** This contribution is associated with the curvature of the phase front from the substitution antenna to the test antenna. The standard uncertainty of the contribution, due to range length, is designated throughout all parts of ETR 273 [12] as  $u_{j16}$ . The standard uncertainty is 0,00 dB if ANSI dipoles are used. For other types of antenna the standard uncertainty of the contribution should be obtained from table 25.

**Table 25: Uncertainty contribution of the range length (verification)**

Range length (i.e. the horizontal distance between phase centres)	Standard uncertainty of the contribution
$(d_1+d_2)^2/4\lambda \leq \text{range length} < (d_1+d_2)^2/2\lambda$	1,26 dB
$(d_1+d_2)^2/2\lambda \leq \text{range length} < (d_1+d_2)^2/\lambda$	0,30 dB
$(d_1+d_2)^2/\lambda \leq \text{range length} < 2(d_1+d_2)^2/\lambda$	0,10 dB
range length $\geq 2(d_1+d_2)^2/\lambda$	0,00 dB

NOTE 6: In table 25,  $d_1$  and  $d_2$  are the maximum dimensions of the antennas.

NOTE 7: The standard uncertainty of the contribution due to the range length is taken as 0,00 dB since in this case the range length is  $\geq 2(d_1+d_2)^2/\lambda$ .

**Reflectivity of absorbing material: substitution antenna to the test antenna:** This uncertainty is associated with the magnitude of the reflections occurring from the side walls, end walls and ceiling. These magnitudes are a function of the quality of the absorber at the frequency of test. However, in this, a substitution measurement, the contribution is only concerned with taking into account the possible differences in the antenna patterns (principally in the vertical plane) between the EUT and substitution antenna. The standard uncertainty of the contribution due to the reflectivity of the absorbing material between the substitution and test antenna is designated throughout all parts of ETR 273 [12] as  $u_{j02}$ .

NOTE 8: In this example case the standard uncertainty of the contribution due to the reflectivity of the absorbing material between the substitution and test antenna is 0,50 dB (see annex A).

**Mutual coupling: test antenna to its images in the absorbing material:** This is the uncertainty due to the mutual coupling between the test antenna and its images in the ceiling, side and end walls and is the effect of the change produced in the antenna's input impedance and/or gain. As this is the second stage of a substitution measurement and the uncertainty is common to both stages it will only contribute in this stage if the test antenna is located at a different height on the antenna mast from the first stage. The standard uncertainty of the contribution, due to the mutual coupling of the test antenna to its images in the absorbing material, is designated throughout all parts of ETR 273 [12] as  $u_{j06}$ .

NOTE 9: In this example case the standard uncertainty of the contribution due to the mutual coupling of the test antenna to its images in the absorbing material is taken as 0,50 dB since this is the second stage of a substitution measurement and the test antenna is assumed to be located at a different height to stage one and therefore the contribution does not cancel.

**Mutual coupling: test antenna to its image in the ground plane:** As this is the second stage of a substitution measurement and the uncertainty is common to both stages it will only contribute in this stage if the test antenna is located at a different height on the antenna mast from the first stage. The standard uncertainty of the contribution, due to the mutual coupling of the test antenna to its image in the ground plane, is designated throughout all parts of ETR 273 [12] as  $u_{j14}$ .

NOTE 10: In this example case the standard uncertainty of the contribution due to the mutual coupling of the test antenna to its image in the ground plane is taken as 0,50 dB since this is the second stage of a substitution measurement and the test antenna is assumed to be located at a different height to stage one and therefore the contribution does not cancel.

#### 6.8.3.2.2.6 Test antenna

**Correction: measurement distance:** For those tests in which the test antenna on the mast peaks at different heights in the two stages, a correction should be made to account for the different measurement distances. Where a correction is required the standard uncertainty of the correction factor should be taken as 0,10 dB. The standard uncertainty of the contribution due to the correction for measurement distance is designated throughout all parts of ETR 273 [12] as  $u_{j18}$ .

NOTE 1: In this example case the standard uncertainty of the contribution due to the correction for measurement distance is taken as 0,10 dB since it is assumed that, in this second stage, a different height of test antenna has been necessary and the correction applied.

**Correction: off boresight angle in elevation plane:** For those tests in which the test antenna on the mast peaks at different heights in the two stages, a correction should be made to account for the different angles subtended by the EUT/substitution antenna. Where a correction is required the standard uncertainty of the correction factor should be taken as 0,10 dB. The standard uncertainty of the contribution due to the correction for off boresight angle in elevation plane is designated throughout all parts of ETR 273 [12] as  $u_{j17}$ .

NOTE 2: In this example case the standard uncertainty of the contribution due to the correction for off boresight angle in the elevation plane is taken as 0,10 dB since it is assumed that, in this second stage, a different height of test antenna has been necessary and the correction applied.

**Antenna: gain of the test antenna:** The gain, and its uncertainty, of the test antenna act as systematic offsets since they are present in both stages of the test. The standard uncertainty of the contribution, due to the uncertainty of the gain of the test antenna, is designated throughout all parts of ETR 273 [12] as  $u_{j45}$ .

NOTE 3: In this example case the standard uncertainty of the contribution due to the uncertainty of the gain of the test antenna is taken as 0,00 dB since the uncertainty is systematic i.e. it produces the same offset in both stages.

**Antenna: tuning of the test antenna:** This uncertainty is introduced as a result of inaccurate tuning of the test antenna. The standard uncertainty of the contribution, due to the tuning of the test antenna, is designated throughout all parts of ETR 273 [12] as  $u_{j46}$ .

NOTE 4: In this example case the standard uncertainty of the contribution due to the tuning of the test antenna is taken as 0,00 dB since the uncertainty is systematic i.e. it is assumed constant and common to both stages of the measurement and, provided that once set in stage one of the test it is not subsequently re-tuned, its contribution is the same in both stages.



**Position of the phase centre: test antenna:** The horizontal position of the test antenna defines one end of the range length. The standard uncertainty of the contribution, due to the position of the phase centre of the test antenna, is designated throughout all parts of ETR 273 [12] as  $u_{j22}$ .

NOTE 5: In this example case the test antenna is assumed to describe a vertical straight line as its height on the mast is changed. The standard uncertainty of the contribution due to the position of the phase centre of the test antenna is assumed to be 0,00 dB (see annex A).

#### 6.8.3.2.2.7 Test antenna attenuator

**Insertion loss: test antenna attenuator:** The attenuator has an insertion loss as well as an uncertainty associated with the measurement of its magnitude. The value of insertion loss and its uncertainty remain valid provided the attenuator is not used outside the manufacturer's specification. At any given frequency the insertion loss acts as a systematic offset and contributes equally to both stages of the measurement. The standard uncertainty of the contribution due to the insertion loss of the test antenna attenuator is designated throughout all parts of ETR 273 [12] as  $u_{j40}$ .

NOTE: In this example case the standard uncertainty of the contribution, due to the insertion loss uncertainty of the test antenna attenuator, is taken as 0,00 dB since the uncertainty is systematic i.e. it produces the same offset in both stages.

#### 6.8.3.2.2.8 Test antenna cable

**Insertion loss: test antenna cable:** The test antenna cable has an insertion loss as well as an uncertainty associated with the measurement of its magnitude. The value of insertion loss and its uncertainty remain valid provided the cable is not used outside the manufacturer's specification. At any given frequency the insertion loss acts as a systematic offset and contributes equally to both stages of the measurement. The standard uncertainty of the contribution, due to the insertion loss uncertainty of the test antenna cable, is designated throughout all parts of ETR 273 [12] as  $u_{j41}$ .

NOTE 1: In this example case the standard uncertainty of the contribution due to the insertion loss uncertainty of the test antenna cable is taken as 0,00 dB since the uncertainty is systematic i.e. it produces the same offset in both stages.

**Cable factor: test antenna cable:** Cable factor is defined as the total effect of the antenna cable's influence on the measuring system including its interaction with the site. It consists of the leakage caused by cable screening inefficiency, parasitic effects (acting as a director or reflector) on the test antenna and introducing an unbalanced, common mode current into the dipole balun. In a radiated measurement the standard uncertainty of the cable factor, associated with each cable, is 0,5 dB provided that the precautions detailed in the methods have been observed. i.e. routing and dressing of cables with ferrites. If no prevention has been attempted the standard uncertainty is 4,0 dB (justification for these values is given in ETR 273 [12], part 1, subpart 2, annex E). The standard uncertainty of the contribution due to the cable factor of the test antenna cable is designated throughout all parts of ETR 273 [12] as  $u_{j19}$ .

NOTE 2: In this example case the standard uncertainty of the contribution due to the cable factor of the test antenna cable is taken as 0,50 dB since in this measurement, the cable changes position in both stages (the height of the test antenna being optimized in both stages) even though the precautions detailed in the methods have been observed.

#### 6.8.3.2.2.9 Receiving device

Whereas the first stage of a spurious emission test is to observe and record the received level from the EUT on the receiving device, the second stage involves the adjustment of the output level of a signal generator to achieve the same received level from a substitution antenna. As a consequence of this methodology, the receiving device contributes neither linearity nor absolute level uncertainty to either stage of the test.

**Receiving device: absolute level:** The standard uncertainty of the contribution, due to the absolute level uncertainty of the receiving device, is designated throughout all parts of ETR 273 [12] as  $u_{j47}$ .

NOTE 1: In this example case the standard uncertainty of the contribution, due to the absolute level uncertainty of the receiving device is taken as 0,00 dB.

**Receiving device: linearity:** The standard uncertainty of the contribution, due to the receiving device linearity, is designated throughout all parts of ETR 273 [12] as  $u_{j48}$ .

NOTE 2: In this example case the standard uncertainty of the contribution due to the receiving device linearity is taken as 0,00 dB.

### 6.8.3.2.3 Contribution from the random component

**Random uncertainty:** The magnitude can be assessed from multiple measurements of the substitution measurement. The standard uncertainty of the contribution due to the random uncertainty is designated throughout all parts of ETR 273 [12] as  $u_{j01}$ .

The substitution measurement was repeated 10 times. The following levels were set on the signal generator in dBm (before correcting for cabling and attenuator network insertion loss):

- -20,1; -20,1; -20,2; -20,2; -20,1; -20,1; -20,2; -20,3; -20,3; -20,3.

Converting to linear terms:

- $9,772 \times 10^{-3}$ ;  $9,772 \times 10^{-3}$ ;  $9,550 \times 10^{-3}$ ;  $9,550 \times 10^{-3}$ ;  $9,772 \times 10^{-3}$ ;  $9,772 \times 10^{-3}$ ;  $9,550 \times 10^{-3}$ ;  $9,333 \times 10^{-3}$ ;  $9,333 \times 10^{-3}$ ;  $9,333 \times 10^{-3}$ .

The two sums  $X$  and  $Y$  are calculated:

- $X$  = the sum of the measured values =  $95,737 \times 10^{-3}$ ;
- $Y$  = the sum of the squares of the measured values =  $916,89 \times 10^{-6} \text{ W}^2$ .

$$u_{c \text{ random}} = \sqrt{\frac{Y - \frac{X^2}{n}}{n-1}} = \sqrt{\frac{916,89 \times 10^{-6} - \frac{(95,737 \times 10^{-3})^2}{10}}{10-1}} = 192,3 \times 10^{-6} \text{ (formula 5.6)}$$

As the result is obtained as the mean value of 10 measurements and the standard uncertainty of the random uncertainty is:

$$u_{j \text{ random}} = \frac{192,3 \times 10^{-6}}{9,5737 \times 10^{-3}} \times \frac{100}{23,0} = 0,175 \text{ dB}$$

NOTE: In this example case the standard uncertainty of the contribution due to the random uncertainty is 0,05 dB.

#### 6.8.3.2.4 Summary table of contributory components

All the uncertainties contributions for this part of the procedure are listed in table 26.

**Table 26: Contributions from the substitution**

<b>u<sub>j</sub> or i</b>	<b>Description of uncertainty contributions</b>	<b>dB</b>
u <sub>j36</sub>	mismatch: transmitting part	0,11
u <sub>j37</sub>	mismatch: receiving part	0,00
u <sub>j38</sub>	signal generator: absolute output level	0,58
u <sub>j39</sub>	signal generator: output level stability	0,00
u <sub>j41</sub>	insertion loss: substitution antenna cable	0,29
u <sub>j19</sub>	cable factor: substitution antenna cable	0,50
u <sub>j40</sub>	insertion loss: substitution antenna attenuator	0,17
u <sub>j45</sub>	antenna: gain of the substitution antenna	0,30
u <sub>j46</sub>	antenna: tuning of the substitution antenna	0,06
u <sub>j22</sub>	position of the phase centre: substitution antenna	0,02
u <sub>j34</sub>	ambient effect	0,00
u <sub>j06</sub>	mutual coupling: substitution antenna to its images in the absorbing material	0,50
u <sub>j14</sub>	mutual coupling: substitution antenna to its image in the ground plane	0,58
u <sub>j11</sub>	mutual coupling: substitution antenna to the test antenna	0,00
u <sub>j12</sub>	mutual coupling: interpolation of mutual coupling and mismatch loss correction factors	0,00
u <sub>j16</sub>	range length	0,00
u <sub>j02</sub>	reflectivity of absorbing material: substitution antenna to the test antenna	0,50
u <sub>j06</sub>	mutual coupling: test antenna to its images in the absorbing material	0,50
u <sub>j14</sub>	mutual coupling: test antenna to its image in the ground plane	0,50
u <sub>j18</sub>	correction: measurement distance	0,10
u <sub>j17</sub>	correction: off boresight angle in elevation plane	0,10
u <sub>j45</sub>	antenna: gain of the test antenna	0,00
u <sub>j46</sub>	antenna: tuning of the test antenna	0,00
u <sub>j22</sub>	position of the phase centre: test antenna	0,00
u <sub>j40</sub>	insertion loss: test antenna attenuator	0,00
u <sub>j41</sub>	insertion loss: test antenna cable	0,00
u <sub>j19</sub>	cable factor: test antenna cable	0,50
u <sub>j47</sub>	receiving device: absolute level	0,00
u <sub>j48</sub>	receiving device: linearity	0,00
u <sub>i01</sub>	random uncertainty	0,175

The standard uncertainties from table 26 should be combined by RSS in accordance with ETR 273 [12], part 1, subpart 1, clause 5. This gives the combined standard uncertainty ( $u_{c \text{ substitution measurement}}$ ) for the NSA measurement in dB.

The value of  $u_{c \text{ substitution measurement}}$  is calculated as 1,56 dB.

#### 6.8.3.2.5 Expanded uncertainty for the spurious emission test

The combined standard uncertainty of the results of the spurious emissions test is the combination of the components outlined in clauses 6.8.3.1.4 and 6.8.3.2.4. The components to be combined are ( $u_{c \text{ EUT measurement}}$ ) and ( $u_{c \text{ substitution measurement}}$ ).

$$u_c = \sqrt{1,47^2 + 1,56^2} = 2,15 \text{ dB}$$

The expanded uncertainty is  $\pm 1,96 \times 2,15 \text{ dB} = \pm 4,21 \text{ dB}$  at a 95 % confidence level.

## 6.8.4 Example 3: Measurement of a receiver parameter (Sensitivity)

For the measurement of receiver sensitivity two stages of test are involved. The first stage (determining the Transform Factor of the site) involves measuring the field strength at the point where the receiver will be placed and determining the relationship between the signal generator output power level and the resulting field strength. The second stage (the EUT measurement) involves replacing the measuring antenna with the EUT and adjusting the output level of the signal generator until the required response is obtained on the receiver. The signal generator output power level is then converted to field strength using the Transform Factor.

### 6.8.4.1 Uncertainty contributions: Stage 1: Transform Factor measurement

The first stage of the receiver sensitivity test is to determine the Transform Factor of the site. This is normally carried out by placing a measuring antenna in the volume occupied by the EUT and determining the relationship between the signal generator output power and the resulting field strength. The test equipment configuration is shown in figure 29. The components shown shaded are common to both stages of the test.

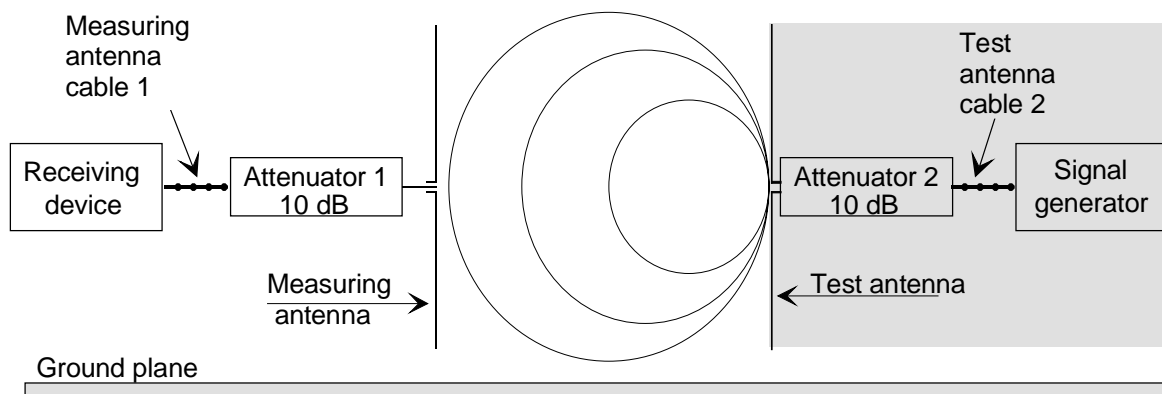

**Figure 29: Stage 1: Transform Factor measurement**

Due to the commonality of all of the components from the test antenna to the receiver in both stages of the test, the mismatch uncertainty contributes identically to both stages and hence does not contribute to the combined standard uncertainty of the measurement. Similarly, for the systematic uncertainty contributions (e.g. test antenna cable loss etc.) of the individual components.

Whereas figure 29 shows, schematically, the equipment set-up for this stage of the receiver sensitivity test, an analysis diagram of the individual components (each of which contributes its own uncertainty) for this stage of the measurement is shown in figure 30. Again, as stated above, the shaded areas represent components common to both stages of the receiver sensitivity test.

#### 6.8.4.1.1 Contributions from the mismatch components

**Mismatch in the transmitting and receiving part:** The value of the combined standard uncertainty of the contribution due to the mismatch are calculated from the approach described in annex G. For this stage is calculated in two parts. Firstly the standard uncertainty of the contribution due to the mismatch in the transmitting part, i.e. between the signal generator, cable, attenuator and the test antenna and secondly, that for the receiving part, i.e. between the receiving antenna, attenuator, cable and the receiving device.

#### **Mismatch: transmitting part:**

The standard uncertainty of the contribution due to mismatch in the transmitting part is designated throughout all parts of ETR 273 [12] as  $u_{j36}$ .

**NOTE:** In this example case the uncertainty due to mismatch in the receiving part is taken as 0,00 dB since the uncertainty is systematic i.e. it produces the same offset in both stages.

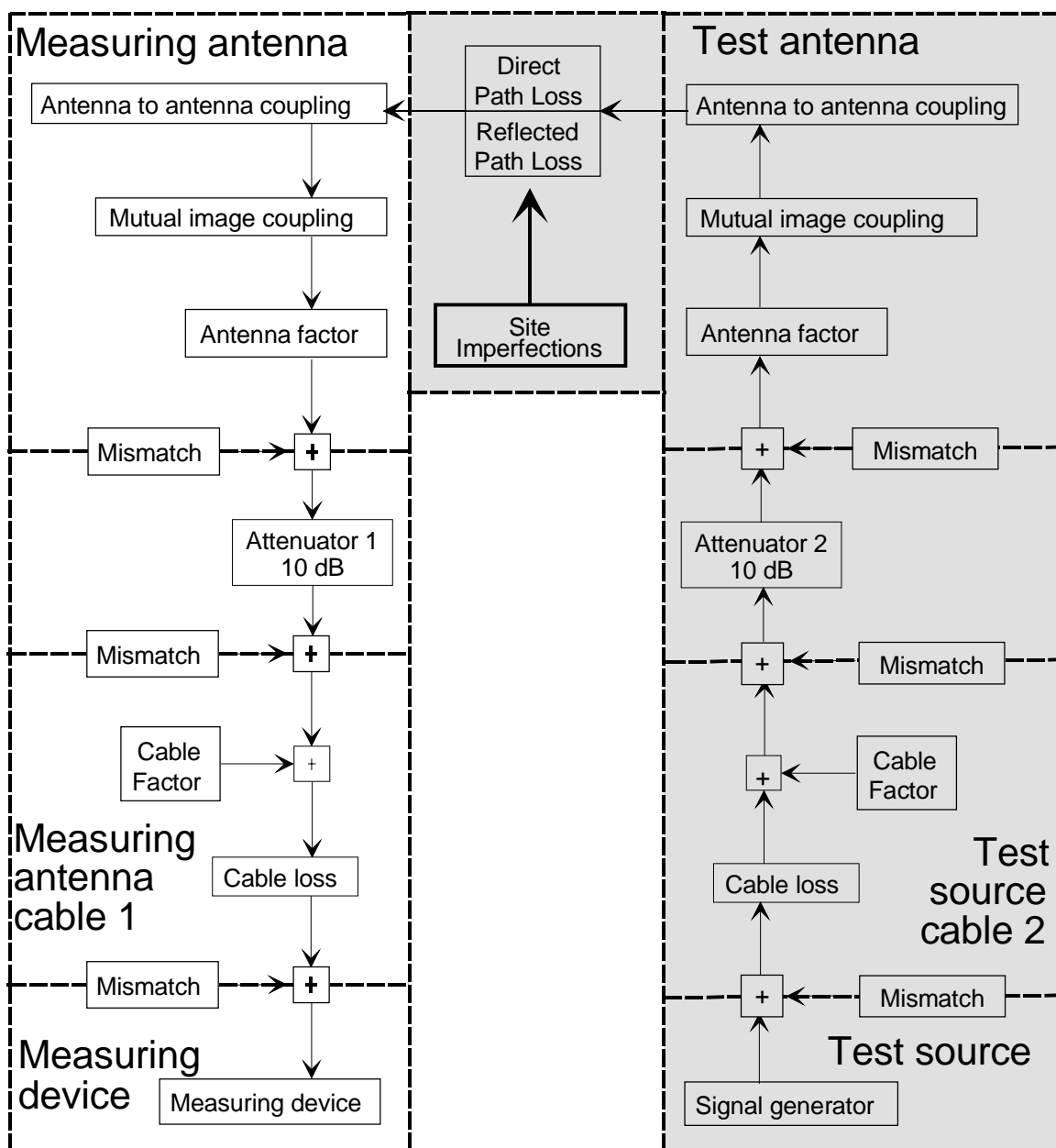

Figure 30: Schematic of the Transform Factor measurement

**Mismatch: receiving part:**

Measuring antenna:	Input reflection coefficient: $ \rho_{RA} $	= 0,333
Attenuator:	Input and output reflection coefficients $ S_{11}  =  S_{22} $	= 0,05
	Attenuation = 10 dB $ S_{12}  =  S_{21} $	= 0,3162
Cable:	Input and output reflection coefficients: $ S_{11} $ and $ S_{22} $	= 0,07
	Attenuation: 1 dB = $ S_{12}  =  S_{21} $	= 0,891
Measuring device:	Input reflection coefficient: $ \rho_{RD} $	= 0,20

$$u_{j \text{ mismatch: antenna and attenuator 2}} = \frac{0,333 \times 0,05 \times 100}{\sqrt{2}} \% = 1,177\%$$

-  $u_{j \text{ attenuator 2 and cable 2}}$ : Constant for both stage 1 and 2. Hence this value does not contribute.

- $u_{j \text{ cable 2 and receiving device}}$ : Constant for both stage 1 and 2. Hence this value does not contribute.

$$u_{j \text{ cable 1 and antenna}} = \frac{0,333 \times 0,07 \times 0,316^2 \times 100}{\sqrt{2}} \% = 0,165\%$$

- $u_{j \text{ attenuator 2 and receiving device}}$ : Constant for both stage 1 and 2. Hence this value does not contribute.

$$u_{j \text{ antenna and receiving device}} = \frac{0,333 \times 0,2 \times 0,316^2 \times 0,891^2 \times 100}{\sqrt{2}} \% = 0,373\%$$

The combined standard uncertainty of the mismatch is then calculated:

$$u_{j \text{ mismatch:measuring part}} = \sqrt{1,177^2 + 0,165^2 + 0,373^2} = 1,25\%$$

Transforming to the logarithmic form (ETR 028 [15], part 2, annex E):  $1,24 \% / 11,5 = 0,11 \text{ dB}$ .

The standard uncertainty of the contribution, due to the mismatch in the direct attenuation measurement, is designated throughout all parts of ETR 273 [12] as  $u_{j37}$ . Its value in this example is 0,11 dB.

#### 6.8.4.1.2 Contributions from the individual components

##### 6.8.4.1.2.1 Signal generator

**Signal generator: absolute output level:** There is not necessarily any similarity between the output levels from the signal generator in the two stages of this test. As a result it contributes to both stages. The standard uncertainty of the contribution, due to the signal generator absolute output level, is designated throughout all parts of ETR 273 [12] as  $u_{j38}$ . Its value can be derived from manufacturer's data sheet.

NOTE 1: In this example case the uncertainty of the contribution due to the signal generator absolute output level uncertainty is taken from the manufacturers data sheet as  $\pm 1,0 \text{ dB}$ . As nothing is said about the distribution of this uncertainty, a rectangular distribution (see ETR 273 [12], part 1, subpart 1, clause 5.1.2) in log is assumed, and the standard uncertainty is calculated as 0,58 dB.

**Signal generator: output level stability:** In any test in which the contribution of the absolute level uncertainty of the signal generator contributes to the combined standard uncertainty of the test i.e. it does not cancel due to the methodology, the contribution from the output level stability is considered to have been included in the signal generator absolute output level,  $u_{j38}$ . Conversely, for any level in which the absolute level uncertainty of the signal generator does not contribute to the combined standard uncertainty, the output level stability of the signal generator should be included. The standard uncertainty of the contribution due to the signal generator output level stability is designated throughout all parts of ETR 273 [12] as  $u_{j39}$ . Its value can be derived from manufacturers' data sheet.

NOTE 2: In this example case the standard uncertainty of the contribution due to the signal generator output level stability is taken as 0,0 dB as it is covered by the absolute level uncertainty.

##### 6.8.4.1.2.2 Test antenna cable

**Insertion loss: test antenna cable:** The test antenna cable has an insertion loss as well as an uncertainty associated with the measurement of its magnitude. The value of insertion loss and its uncertainty remain valid provided the cable is not used outside the manufacturer's specification. At any given frequency the insertion loss acts as a systematic offset and contributes equally to both stages of the measurement. The standard uncertainty of the contribution due to the insertion loss uncertainty of the test antenna cable, is designated throughout all parts of ETR 273 [12] as  $u_{j41}$ .

NOTE 1: In this example case the standard uncertainty of the contribution due to the insertion loss uncertainty of the test antenna cable is taken as 0,00 dB since the uncertainty is systematic i.e. it produces the same offset in both stages.

**Cable factor: test antenna cable:** Cable factor is defined as the total effect of the antenna cable's influence on the measuring system including its interaction with the site. It consists of the leakage caused by cable screening inefficiency, parasitic effects (acting as a director or reflector) on the test antenna and introducing an unbalanced, common mode current into the dipole balun. In a radiated measurement the standard uncertainty of the cable factor, associated with each cable, is 0,5 dB provided that the precautions detailed in the methods have been observed. i.e. routing and dressing of cables with ferrites. If no prevention has been attempted the standard uncertainty is 4,0 dB (justification for these values is given in ETR 273 [12], part 1, subpart 2, annex E). The standard uncertainty of the contribution due to the cable factor of the test antenna cable is designated throughout all parts of ETR 273 [12] as  $u_{j19}$ .

NOTE 2: In this example case the standard uncertainty of the contribution due to the cable factor of the test antenna cable is taken as 0,00 dB since in this measurement, the cable position, once set in this stage is not subsequently changed during the test.

#### 6.8.4.1.2.3 Test antenna attenuator

**Insertion loss: test antenna attenuator:** The attenuator has an insertion loss as well as an uncertainty associated with the measurement of its magnitude. The value of insertion loss and its uncertainty remain valid provided the attenuator is not used outside the manufacturer's specification. At any given frequency the insertion loss acts as a systematic offset and contributes equally to both stages of the measurement. The standard uncertainty of the contribution due to the insertion loss of the test antenna attenuator is designated throughout all parts of ETR 273 [12] as  $u_{j40}$ .

NOTE: In this example case the standard uncertainty of the contribution, due to the insertion loss uncertainty of the test antenna attenuator, is taken as 0,00 dB since the uncertainty is systematic i.e. it produces the same offset in both stages.

#### 6.8.4.1.2.4 Test antenna

**Correction: measurement distance:** For those tests in which the test antenna on the mast peaks at different heights in the two stages, a correction for measurement distance must be made to account for the different measurement distances. In this test, once the position of the test antenna is set in stage one no further adjustment to its position is subsequently made during the test. The standard uncertainty of the contribution due to the correction for measurement distance is designated throughout all parts of ETR 273 [12] as  $u_{j18}$ .

NOTE 1: In this example case the standard uncertainty of the contribution due to the correction for measurement distance is taken as 0,00 dB.

**Correction: off boresight angle in elevation plane:** For those tests in which the test antenna on the mast peaks at different heights in the two stages, a correction must be made to account for the different angles subtended by the EUT/substitution antenna. In this test, once the position of the test antenna is set in stage one no further adjustment to its position is subsequently made during the test. The standard uncertainty of the contribution due to the correction for off boresight angle in elevation plane is designated throughout all parts of ETR 273 [12] as  $u_{j17}$ .

NOTE 2: In this example case the standard uncertainty of the contribution due to the correction for off boresight angle in elevation plane is taken as 0,00 dB.

**Antenna: gain of the test antenna:** The gain, and its uncertainty, of the test antenna act as systematic offsets since they are present in both stages of the test. The standard uncertainty of the contribution, due to the uncertainty of the gain of the test antenna, is designated throughout all parts of ETR 273 [12] as  $u_{j45}$ .

NOTE 3: In this example case the standard uncertainty of the contribution due to the uncertainty of the gain of the test antenna is taken as 0,00 dB since the uncertainty is systematic i.e. it produces the same offset in both stages.

**Antenna: tuning of the test antenna:** This uncertainty is introduced as a result of inaccurate tuning of the test antenna. The standard uncertainty of the contribution, due to the tuning of the test antenna, is designated throughout all parts of ETR 273 [12] as  $u_{j46}$ .

NOTE 4: In this example case the standard uncertainty of the contribution due to the tuning of the test antenna is taken as 0,00 dB since the uncertainty is systematic i.e. it is assumed constant and common to both stages of the measurement and, provided that once set in stage one of the test it is not subsequently re-tuned, its contribution is the same in both stages.

**Position of the phase centre: test antenna:** The horizontal position of the test antenna defines one end of the range length. The standard uncertainty of the contribution, due to the position of the phase centre of the test antenna, is designated throughout all parts of ETR 273 [12] as  $u_{j22}$ .

NOTE 5: In this example case the test antenna is assumed to describe a vertical straight line as its height on the mast is changed. The standard uncertainty of the contribution due to the position of the phase centre of the test antenna is assumed to be 0,00 dB (see annex A).

#### 6.8.4.1.2.5 Site factors

**Ambient effect: Ambient effect:** Ambient effect is the uncertainty caused by local ambient signals raising the noise floor at the measurement frequency. The standard uncertainty of the contribution, due to the ambient effect, is designated throughout all parts of ETR 273 [12] as  $u_{j34}$ . The values of the standard uncertainty should be taken from table 27.

**Table 27: Uncertainty contribution: Ambient effect**

Receiving device noise floor (EUT OFF) is within:	Standard uncertainty of the contribution
3 dB of measurement	1,57 dB
3 dB to 6 dB of measurement	0,80 dB
6 dB to 10 dB of measurement	0,30 dB
10 dB to 20 dB of measurement	0,10 dB
20 dB or more of the measurement	0,00 dB

NOTE 1: In this example case the standard uncertainty of the contribution due to the ambient effect is taken as 0,00 dB, since the chamber is assumed to be shielded.

**Mutual coupling: test antenna to its images in the absorbing material:** This is the uncertainty due to the mutual coupling between the test antenna and its images in the ceiling, side and end walls and is the effect of the change produced in the antenna's input impedance and/or gain. The standard uncertainty of the contribution due to the mutual coupling between the test antenna and its images in the absorbing material is designated throughout all parts of ETR 273 [12] as  $u_{j06}$ .

NOTE 2: In this example case the standard uncertainty of the contribution due to the mutual coupling between the test antenna and its images in the absorbing material is taken as 0,00 dB since this is the first stage of a two stage measurement, where, in the second stage, the test antenna is located at the same height on the mast as in this, the first stage.

**Mutual coupling: test antenna to its image in the ground plane:** This is the uncertainty due to the mutual coupling between the test antenna and its image in the ground plane and is the effect of the change produced in the antenna's input impedance and/or gain when placed close to a ground plane. The standard uncertainty of the contribution due to the mutual coupling between the test antenna and its image in the ground plane is designated throughout all parts of ETR 273 [12] as  $u_{j14}$ .

NOTE 3: In this example case the standard uncertainty of the contribution due to the mutual coupling between the test antenna and its image in the ground plane is taken as 0,00 dB since this is the first stage of a two stage measurement, where, in the second stage, the test antenna is located at the same height on the mast as in this, the first stage.

**Mutual coupling: measuring antenna to the test antenna:** This is the effect produced by any change in gain of the antennas which results from their close spacing. The standard uncertainty of the contribution due to the mutual coupling of the measuring antenna to the test antenna, designated throughout all parts of ETR 273 [12] as  $u_{j11}$ , It has a standard uncertainty of 0,00 dB for ANSI dipoles since it is included, where significant, in the mutual coupling and mismatch loss correction factors. For non-ANSI dipoles the standard uncertainty can be taken from table 28.



**Table 28: Uncertainty contribution of the mutual coupling between the measuring and test antenna**

Frequency	Standard uncertainty of the contribution (3 m range)	Standard uncertainty of the contribution (10 m range)
30 MHz ≤ frequency < 80 MHz	1,73 dB	0,60 dB
80 MHz ≤ frequency < 180 MHz	0,6 dB	0,00 dB
frequency ≥ 180 MHz	0,00 dB	0,00 dB

NOTE 4: In this example case the standard uncertainty of the contribution due to mutual coupling between the measuring and test antennas is taken as 0,00 dB as we are using ANSI dipoles.

**Mutual coupling: interpolation of mutual coupling and mismatch loss correction factors, only for ANSI dipoles:**

The standard uncertainty of the contribution, due to the interpolation of mutual coupling and mismatch loss correction factors, is designated throughout all parts of ETR 273 [12] as  $u_{j12}$ . It has, for spot frequencies given in table A.20, a value of 0,00 dB. However, for all other frequencies, the standard uncertainty should be obtained from table 29.

**Table 29: Uncertainty contribution of the interpolation of mutual coupling and mismatch loss correction factors**

Frequency (MHz)	Standard uncertainty of the contribution
for a spot frequency given in the table	0,00 dB
30 MHz ≤ frequency < 80 MHz	0,58 dB
80 MHz ≤ frequency < 180 MHz	0,17 dB
frequency ≥ 180 MHz	0,00 dB

NOTE 5: In this example case the standard uncertainty of the contribution, due to the interpolation of mutual coupling and mismatch loss correction factors, is taken as 0,00 dB as the frequency is above 180 MHz.

**Range length:** This contribution is associated with the curvature of the phase front from the measuring antenna to the test antenna. The standard uncertainty of the contribution, due to range length, is designated throughout all parts of ETR 273 [12] as  $u_{j16}$ . The standard uncertainty is 0,00 dB if ANSI dipoles are used. For other types of antenna the standard uncertainty of the contribution should be obtained from table 30.

**Table 30: Uncertainty contribution of the range length (verification)**

Range length (i.e. the horizontal distance between phase centres)	Standard uncertainty of the contribution
$(d_1+d_2)^2/4\lambda \leq \text{range length} < (d_1+d_2)^2/2\lambda$	1,26 dB
$(d_1+d_2)^2/2\lambda \leq \text{range length} < (d_1+d_2)^2/\lambda$	0,30 dB
$(d_1+d_2)^2/\lambda \leq \text{range length} < 2(d_1+d_2)^2/\lambda$	0,10 dB
$\text{range length} \geq 2(d_1+d_2)^2/\lambda$	0,00 dB

NOTE 6: In table 30,  $d_1$  and  $d_2$  are the maximum dimensions of the antennas.

NOTE 7: In this example case the standard uncertainty of the contribution, due to the range length, is taken as 0,00.

**Reflectivity of absorbing material: measuring antenna to the test antenna:** This uncertainty is the residual effect of the reflections in the absorbing materials which result from the measuring antenna and EUT having different elevation patterns. The standard uncertainty of the contribution due to the reflectivity of absorbing material between the measuring and test antenna is designated throughout all parts of ETR 273 [12] as  $u_{j02}$ .

NOTE 8: In this example case the standard uncertainty of the contribution due to the reflectivity of absorbing material between the measuring and test antenna is taken as 0,00 dB since a reference is set.

**Mutual coupling: measuring antenna to its images in the absorbing material:** This uncertainty is the effect of the change produced in the antenna's input impedance and/or gain. The standard uncertainty of the contribution, due to the mutual coupling between the measuring antenna and its images in the absorbing material, is designated throughout all parts of ETR 273 [12] as  $u_{j06}$ .

NOTE 9: In this example case the standard uncertainty of the contribution due to the mutual coupling between the measuring antenna and its images in the absorbing material is taken as 0,5 dB.

**Mutual coupling: measuring antenna to its image in the ground plane:** This uncertainty is the effect of the change produced in the antenna's input impedance and/or gain. The standard uncertainty of the contribution, due to the mutual coupling of the measuring antenna to its image in the ground plane, is designated throughout all parts of ETR 273 [12] as  $u_{j14}$ . Its value can be obtained from table 31.

**Table 31: Uncertainty contribution of the mutual coupling between the measuring antenna and its image in the ground plane**

Spacing between the antenna and the ground plane	Standard uncertainty of the contribution
<b>For a vertically polarised antenna</b>	
spacing $\leq 1,25 \lambda$	0,15 dB
spacing $> 1,25 \lambda$	0,06 dB
<b>For a horizontally polarized antenna</b>	
spacing $< \lambda/2$	1,15 dB
$\lambda/2 \leq$ spacing $< 3\lambda/2$	0,58 dB
$3\lambda/2 \leq$ spacing $< 3\lambda$	0,29 dB
spacing $\geq 3\lambda$	0,15 dB

NOTE 10: In this example case the standard uncertainty of the contribution due to the mutual coupling of the measuring antenna to its image in the ground plane is taken as 0,15 dB since we are assuming vertical polarization and a spacing of  $< 1,25 \lambda$ .

#### 6.8.4.1.2.6 Measuring antenna

**Antenna: antenna factor of the measuring antenna:** Uncertainty is introduced as a result of the inaccurate knowledge of the antenna factor of the measuring antenna. The antenna factor of the measuring antenna is only involved in the second stage of the test and therefore does not act as a systematic offset. The standard uncertainty of the contribution, due to the antenna factor of the measuring antenna, is designated throughout all parts of ETR 273 [12] as  $u_{j44}$ . For ANSI dipoles the value should be obtained from table 32.

**Table 32: Uncertainty contribution of the antenna factor of the measuring antenna.**

Frequency	Standard uncertainty of the contribution
30 MHz $\leq$ frequency $< 80$ MHz	1,73 dB
80 MHz $\leq$ frequency $< 180$ MHz	0,60 dB
frequency $\geq 180$ MHz	0,30 dB

NOTE 1: For other antenna types the figures should be taken from manufacturers data sheets. If a figure is not given the standard uncertainty is 1,0 dB.

NOTE 2: In this example case the standard uncertainty of the contribution due to the antenna factor uncertainty of the receiving antenna is 0,30 dB since ANSI dipoles have been used and the frequency is above 180 MHz.

**Antenna: tuning of the measuring antenna** Uncertainty is introduced as a result of the inaccurate tuning of the measuring antenna. The standard uncertainty of the contribution due to the tuning of the measuring antenna is designated in the present document by  $u_{j46}$ .

NOTE 3: In this example case the standard uncertainty of the contribution due to the tuning of the measuring antenna is taken to be 0,06 dB (see annex A) since the tuning of the measuring antenna is only involved in this stage of the test and therefore does not act as a systematic offset.

**Position of the phase centre: measuring antenna:** Uncertainty is introduced as a result of the inaccurate positioning of the phase centre of the measuring antenna, since it affects the range length i.e. the horizontal distance between itself and the test antenna. The standard uncertainty of the contribution, due to the position of the phase centre of the measuring antenna, is designated throughout all parts of ETR 273 [12] as  $u_{j22}$ .

NOTE 4: In this example case the standard uncertainty of the contribution due to the position of the phase centre of the receiving antenna has been calculated from  $\pm$  (the offset)/(range length) x 100 %. The positioning uncertainty is  $\pm 0,01$  m and therefore the worst case uncertainty =  $0,01/3,0 = 0,333$  %. As the offset can be anywhere between these limits, the uncertainty is taken to be rectangularly distributed (see ETR 273 [12], part 1, subpart 1, clause 5.1.2) and the standard uncertainty is calculated as 0,192 %. This is transformed to the logarithmic form (ETR 028 [15], part 2, annex E), to be 0,02 dB.

#### 6.8.4.1.2.7 Measuring antenna attenuator

**Insertion loss: measuring antenna attenuator:** The attenuator has an insertion loss as well as an uncertainty associated with the measurement of its magnitude. The value of insertion loss and its uncertainty remain valid provided the attenuator is not used outside the manufacturer's specification. At any given frequency the insertion loss is taken from the manufacturer's data sheet since it does not cancel as a systematic offset (it only appears in one stage of the test). The standard uncertainty of the contribution, due to the insertion loss uncertainty of the measuring antenna attenuator, is designated throughout all parts of ETR 273 [12] as  $u_{j40}$ .

NOTE: In this example case the uncertainty of the contribution, due to the insertion loss uncertainty of the measuring antenna attenuator, is taken from the manufacturer's data sheet as  $\pm 0,3$  dB as nothing is said about the distribution, a rectangular distribution (see ETR 273 [12], part 1, subpart 1, clause 5.1.2) in logs is assumed and the standard uncertainty is calculated as 0,17 dB.

#### 6.8.4.1.2.8 Measuring antenna cable

**Insertion loss: measuring antenna cable:** The measuring antenna cable has an insertion loss as well as an uncertainty associated with the measurement of its magnitude. The value of insertion loss and its uncertainty remain valid provided the cable is not used outside the manufacturer's specification. At any given frequency the insertion loss acts as a systematic offset and contributes equally to both stages of the measurement. The standard uncertainty of the contribution due to the insertion loss uncertainty of the measuring antenna cable, is designated throughout all parts of ETR 273 [12] as  $u_{j41}$ .

NOTE 1: In this example case the uncertainty of the contribution due to the insertion loss uncertainty of the measuring antenna cable is taken from the manufacturer's data sheet as  $\pm 0,5$  dB. As nothing is said about the distribution, a rectangular distribution (see ETR 273 [12], part 1, subpart 1, clause 5.1.2) in logs is assumed and the standard uncertainty is calculated as 0,29 dB.

**Cable factor: measuring antenna cable:** Cable factor is defined as the total effect of the antenna cable's influence on the measuring system including its interaction with the site. It consists of the leakage caused by cable screening inefficiency, parasitic effects (acting as a director or reflector) and introducing an unbalanced, common mode current into the dipole balun. In a radiated measurement the standard uncertainty of the cable factor associated with the measuring antenna cable is 0,5 dB provided the precautions detailed in the method have been observed i.e. routing and dressing the cables with ferrites. If no prevention has been attempted the standard uncertainty is 4,0 dB (justification for these values is given in ETR 273 [12], part 1, subpart 2, annex E). The standard uncertainty of the contribution, due to the cable factor of the measuring antenna cable, is designated throughout all parts of ETR 273 [12] as  $u_{j19}$ .

NOTE 2: In the example case the standard uncertainty of the contribution due to the cable factor of the measuring antenna cable is taken as 0,50 dB since the precautions detailed in the methods are assumed to have been observed.

### 6.8.4.1.2.9 Receiving device

The receiving device is only used in the first stage of this test. Therefore, the absolute level uncertainty contributes fully to this stage although the linearity does not.

**Receiving device: absolute level:** This uncertainty only contributes during the first stage of the measurement. The standard uncertainty of the contribution due to the receiving device absolute level uncertainty is designated throughout all parts of ETR 273 [12] as  $u_{j47}$ . Its value can be derived from manufacturers data.

NOTE 1: In this example case the uncertainty of the contribution due to the receiving device absolute level uncertainty) is obtained from the manufacturers data as  $\pm 1$  dB with a rectangular distribution (see ETR 273 [12], part 1, subpart 1, clause 5.1.2) in logs. The standard uncertainty of the contribution due to the receiving device absolute level uncertainty is calculated as 0,58 dB.

**Receiving device: linearity:** In any test in which the contribution of the absolute level uncertainty of the receiving device contributes to the combined standard uncertainty of the test i.e. it does not cancel due to the methodology, the contribution from the receiving device linearity is considered to have been included in  $u_{j47}$ . Conversely, for any test in which the absolute level uncertainty of the receiving device does not contribute to the combined standard uncertainty the linearity of the receiving device should be included. The standard uncertainty of the contribution due to the receiving device linearity is designated throughout all parts of ETR 273 [12] as  $u_{j48}$ .

NOTE 2: In this example case the standard uncertainty of the contribution due to the receiving device linearity is taken as 0,00 dB.

### 6.8.4.1.3 Contribution from the random component

**Random uncertainty:** The magnitude can be assessed from multiple measurements of the Transform Factor. The standard uncertainty of the contribution due to the random uncertainty is designated throughout all parts of ETR 273 [12] as  $u_{i01}$ .

The Transform Factor measurement was repeated 10 times. The following results were obtained in dB $\mu$ V (before correcting for cabling and attenuator network insertion loss):

- 65,4; 63,4; 66,0; 65,3; 63,0; 64,9; 65,2; 66,8; 65,5; 63,7.

Converting to linear terms:

- $1,862 \times 10^{-3}$ ;  $1,479 \times 10^{-3}$ ;  $1,995 \times 10^{-3}$ ;  $1,841 \times 10^{-3}$ ;  $1,413 \times 10^{-3}$ ;  $1,758 \times 10^{-3}$ ;  $1,820 \times 10^{-3}$ ;  $2,188 \times 10^{-3}$ ;  $1,884 \times 10^{-3}$ ;  $1,531 \times 10^{-3}$ ;

The two sums  $X$  and  $Y$  are calculated:

- $X =$  the sum of the measured values  $= 17,77 \times 10^{-3}$ ;
- $Y =$  the sum of the squares of the measured values  $= 32,10 \times 10^{-6} \text{ V}^2$ .

$$u_{c \text{ random}} = \sqrt{\frac{Y - \frac{X^2}{n}}{n-1}} = \sqrt{\frac{32,10 \times 10^{-6} - \frac{(17,77 \times 10^{-3})^2}{10}}{10-1}} = 238,3 \times 10^{-6} \text{ (formula 5.6)}$$

As the result is obtained as the mean value of 10 measurements and the standard uncertainty of the random uncertainty is:

$$u_{j \text{ random}} = \frac{238,3 \times 10^{-6}}{1,777 \times 10^{-3}} \times \frac{100}{11,5} = 1,17 \text{ dB}$$

NOTE: In this example case the standard uncertainty of the contribution due to the random uncertainty is 1,17 dB.

#### 6.8.4.1.4 Summary table of contributory components

All the uncertainties for this part of the procedure are listed in table 33.

**Table 33: Contributions from the transfer factor measurement**

<b>u<sub>j</sub> or i</b>	<b>Description of uncertainty contributions</b>	<b>dB</b>
U <sub>j36</sub>	mismatch: transmitting part	0,00
U <sub>j37</sub>	mismatch: receiving part	0,11
U <sub>j38</sub>	signal generator: absolute output level	0,58
U <sub>j39</sub>	signal generator: output level stability	0,00
U <sub>j41</sub>	insertion loss: test antenna cable	0,00
U <sub>j19</sub>	cable factor: test antenna cable	0,00
U <sub>j40</sub>	insertion loss: test antenna attenuator	0,00
U <sub>j18</sub>	correction: measurement distance	0,00
U <sub>j17</sub>	correction: off boresight angle in elevation plane ,	0,00
U <sub>j45</sub>	antenna: gain of the test antenna	0,00
U <sub>j46</sub>	antenna: tuning of the test antenna	0,00
U <sub>j22</sub>	position of the phase centre: test antenna	0,00
U <sub>j34</sub>	ambient effect	0,00
U <sub>j06</sub>	mutual coupling: test antenna to its images in the absorbing material	0,00
U <sub>j14</sub>	mutual coupling: test antenna to its image in the ground plane	0,00
U <sub>j11</sub>	mutual coupling: measuring antenna to the test antenna	0,00
U <sub>j12</sub>	mutual coupling: interpolation of mutual coupling and mismatch loss correction factors	0,00
U <sub>j16</sub>	range length	0,00
U <sub>j02</sub>	reflectivity of absorber material: measuring antenna to the test antenna	0,00
U <sub>j06</sub>	mutual coupling: measuring antenna to its images in the absorbing material	0,50
U <sub>j14</sub>	mutual coupling: measuring antenna to its image in the ground plane	0,15
U <sub>j44</sub>	antenna: antenna factor of the measuring antenna	0,30
U <sub>j46</sub>	antenna: tuning of the measuring antenna	0,06
U <sub>j22</sub>	position of the phase centre: measuring antenna	0,02
U <sub>j40</sub>	insertion loss: measuring antenna attenuator	0,17
U <sub>j41</sub>	insertion loss: measuring antenna cable	0,29
U <sub>j19</sub>	cable factor: measuring antenna cable	0,50
U <sub>j47</sub>	receiving device: absolute level	0,58
U <sub>j48</sub>	receiving device: linearity	0,00
U <sub>i01</sub>	random uncertainty	1,17

The standard uncertainties from table 33 should be combined by RSS in accordance with ETR 273 [12], part 1, subpart 1, clause 5. This gives the combined standard uncertainty ( $u_c \text{ Transform Factor}$ ) for the Transform Factor measurement in dB.

The value of  $u_c \text{ Transform Factor}$  is calculated as 1,67 dB.

#### 6.8.4.2 Uncertainty contributions: Stage 2: EUT measurement

The second stage of the measurement (EUT sensitivity measurement) is to determine the minimum signal generator output level which produces the required response from the EUT and converting the output level of the signal generator, to a field strength using the Transform Factor derived in stage one. The test equipment set-up is shown in figure 31. The components shown shaded are common to both stages of the test.

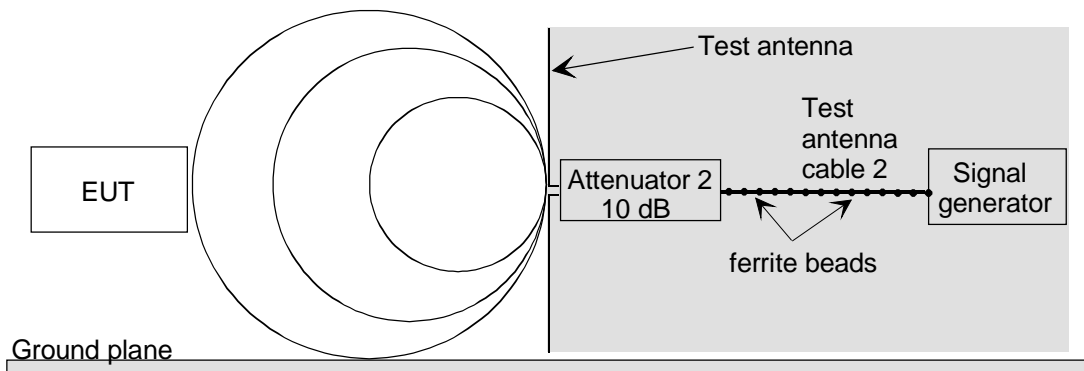

Figure 31: EUT measurement

Whereas figure 31 shows, schematically, the test equipment for the EUT sensitivity measurement, figure 32 an analysis diagram, provides a detailed picture of the individual uncertainty components (each of which contributes its own uncertainty) for this stage in the measurement. As stated above, the shaded areas represent components common to both stages of the test method.

6.8.4.2.1 Contributions from the mismatch components

**Mismatch: transmitting part:** Only the transmitting part of the test equipment set-up is involved in this stage of the test. The standard uncertainty of the contribution due to mismatch is 0,00 dB since, as stated in clause 6.8.4.1.1 the transmitting part is common to both stages of the test.

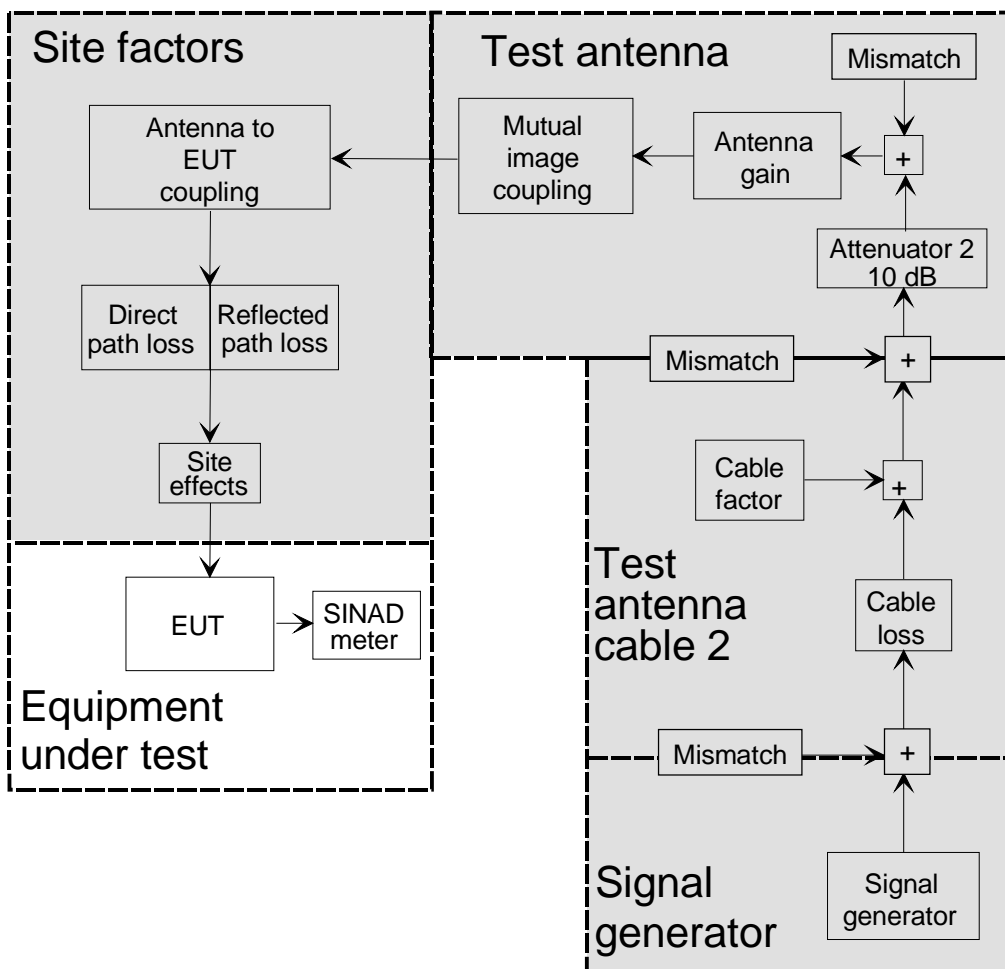

Figure 32: Reference for the measurement on the equipment (sensitivity)

The mismatch uncertainty between the signal generator and the test antenna contributes equally to both stages of the test and therefore it does not contribute to the combined standard uncertainty and is not calculated. The standard uncertainty of the contribution due to mismatch in the transmitting part is designated throughout all parts of ETR 273 [12] as  $u_{j35}$ .

NOTE: In this example case the standard uncertainty of the contribution due to mismatch in the transmitting part is taken as 0,00 dB, since the uncertainty is systematic i.e. it produces the same offset in both stages.

#### 6.8.4.2.2 Contributions from the individual components

##### 6.8.4.2.2.1 Signal generator

**Signal generator: absolute output level:** There is not necessarily any similarity between the output levels from the signal generator in the two stages of this test. As a result it contributes to both stages. The standard uncertainty of the contribution, due to the signal generator absolute output level, is designated throughout all parts of ETR 273 [12] as  $u_{j38}$ . Its value can be derived from manufacturer's data sheet.

NOTE 1: In this example case the uncertainty of the contribution due to the signal generator absolute output level uncertainty is taken from the manufacturers data sheet as  $\pm 1,0$  dB. As nothing is said about the distribution of this uncertainty, a rectangular distribution (see ETR 273 [12], part 1, subpart 1, clause 5.1.2) in logs is assumed, and the standard uncertainty is calculated as 0,58 dB.

**Signal generator: output level stability:** In any test in which the contribution of the absolute level uncertainty of the signal generator contributes to the combined standard uncertainty of the test i.e. it does not cancel due to the methodology, the contribution from the output level stability is considered to have been included in the signal generator absolute output level,  $u_{j38}$ . Conversely, for any level in which the absolute level uncertainty of the signal generator does not contribute to the combined standard uncertainty, the output level stability of the signal generator should be included. The standard uncertainty of the contribution due to the signal generator output level stability is designated throughout all parts of ETR 273 [12] as  $u_{j39}$ . Its value can be derived from manufacturers' data sheet.

NOTE 2: In this example case the standard uncertainty of the contribution due to the signal generator output level stability is taken as 0,00 dB as it is covered by the absolute level uncertainty.

##### 6.8.4.2.2.2 Test antenna cable

**Insertion loss: test antenna cable:** The test antenna cable has an insertion loss as well as an uncertainty associated with the measurement of its magnitude. The value of insertion loss and its uncertainty remain valid provided the cable is not used outside the manufacturer's specification. At any given frequency the insertion loss acts as a systematic offset and contributes equally to both stages of the measurement. The standard uncertainty of the contribution due to the insertion loss uncertainty of the test antenna cable is designated throughout all parts of ETR 273 [12] as  $u_{j41}$ .

NOTE 1: In this example case the standard uncertainty of the contribution due to the insertion loss uncertainty of the test antenna cable is taken as 0,00 dB since the uncertainty is systematic i.e. it produces the same offset in both stages.

**Cable factor: test antenna cable:** Cable factor is defined as the total effect of the antenna cable's influence on the measuring system including its interaction with the site. It consists of the leakage caused by cable screening inefficiency, parasitic effects (acting as a director or reflector) on the test antenna and introducing an unbalanced, common mode current into the dipole balun. In a radiated measurement the standard uncertainty of the cable factor, associated with each cable, is 0,5 dB provided that the precautions detailed in the methods have been observed. i.e. routing and dressing of cables with ferrites. If no prevention has been attempted the standard uncertainty is 4,0 dB (justification for these values is given in ETR 273 [12], part 1, subpart 2, annex E). The standard uncertainty of the contribution due to the cable factor of the test antenna cable is designated throughout all parts of ETR 273 [12] as  $u_{j19}$ .

NOTE 2: In this example case the standard uncertainty of the contribution due to the cable factor of the test antenna cable is taken as 0,00 dB since in this measurement, the cable position, once set in stage 1, is not subsequently changed during the test.

### 6.8.4.2.2.3 Test antenna attenuator

**Insertion loss: test antenna attenuator:** The test antenna attenuator has an insertion loss as well as an uncertainty associated with the measurement of its magnitude. The value of insertion loss and its uncertainty remain valid provided the attenuator is not used outside the manufacturer's specification. At any given frequency the insertion loss acts as a systematic offset and contributes equally to both stages of the measurement. The standard uncertainty of the contribution due to the insertion loss of the test antenna attenuator is designated throughout all parts of ETR 273 [12] as  $u_{j40}$ .

NOTE: In this example case the standard uncertainty of the contribution, due to the insertion loss uncertainty of the test antenna attenuator, is taken as 0,00 dB since the uncertainty is systematic i.e. it produces the same offset in both stages.

### 6.8.4.2.2.4 Test antenna

**Correction: measurement distance:** For those tests in which the test antenna on the mast peaks at different heights in the two stages, a correction for measurement distance must be made to account for the different measurement distances. In this test, once the position of the test antenna is set in stage one no further adjustment to its position is subsequently made during the test. The standard uncertainty of the contribution due to the correction for measurement distance is designated throughout all parts of ETR 273 [12] as  $u_{j18}$ .

NOTE 1: In this example case the standard uncertainty of the contribution due to the correction for measurement distance is taken as 0,00 dB.

**Correction: off boresight angle in elevation plane:** For those tests in which the test antenna on the mast peaks at different heights in the two stages, a correction must be made to account for the different angles subtended by the EUT/substitution antenna. In this test, once the position of the test antenna is set in stage one no further adjustment to its position is subsequently made during the test. The standard uncertainty of the contribution due to the correction for off boresight angle in elevation plane is designated throughout all parts of ETR 273 [12] as  $u_{j17}$ .

NOTE 2: In this example case the standard uncertainty of the contribution due to the correction for off boresight angle in elevation plane is taken as 0,00 dB since the uncertainty is assumed to be systematic i.e. it is assumed constant and common to both stages of the measurement.

**Antenna: gain of the test antenna:** The gain of the test antenna acts as a systematic offset since it is present in both stages of the test. The standard uncertainty of the contribution due to the gain of the test antenna is designated throughout all parts of ETR 273 [12] as  $u_{j45}$ .

NOTE 3: In this example case the standard uncertainty of the contribution due to the gain of the test antenna is taken as 0,00 dB since the uncertainty is assumed to be systematic i.e. it is assumed constant and common to both stages of the measurement.

**Antenna: tuning of the test antenna:** This uncertainty is introduced as a result of inaccurate tuning of the test antenna. The standard uncertainty of the contribution due to the tuning of the test antenna is designated throughout all parts of ETR 273 [12] as  $u_{j46}$ .

NOTE 4: In this example case the standard uncertainty of the contribution due to the tuning of the test antenna is taken as 0,00 dB since the uncertainty is assumed to be systematic i.e. it is assumed constant and common to both stages of the measurement (provided that once set in stage one of the test it is not subsequently re-tuned).

**Position of the phase centre: test antenna:** The horizontal position of the test antenna defines one end of the range length. Since the test antenna position on the mast is not changed after being set in this stage the standard uncertainty of the contribution due to the position of the phase centre of the test antenna is designated throughout all parts of ETR 273 [12] as  $u_{j22}$ .

NOTE 5: In this example case the standard uncertainty of the contribution due to the position of the phase centre of the test antenna is taken as 0,00 dB since the uncertainty is assumed to be systematic i.e. it is assumed constant and common to both stages of the measurement.



## 6.8.4.2.2.5 Site factors

**Ambient effect:** Ambient effect is the uncertainty caused by local ambient signals raising the noise floor at the measurement frequency. The standard uncertainty of the contribution due to the ambient effect is designated throughout all parts of ETR 273 [12] as  $u_{j34}$ . The values of the standard uncertainties for this part of the test should be the same as for stage 1.

NOTE 1: In this example case the standard uncertainty of the contribution due to the ambient effect is taken as 0,00 dB as this was the value in stage 1.

**Range length:** This contribution is associated with the curvature of the phase front from the EUT to the test antenna. The standard uncertainty of the contribution, due to range length, is designated throughout all parts of ETR 273 [12] as  $u_{j16}$ . The standard uncertainty is 0,00 dB if ANSI dipoles are used. For other types of antenna the standard uncertainty of the contribution should be obtained from table 34.

**Table 34: Uncertainty contribution of the range length (verification)**

Range length (i.e. the horizontal distance between phase centres)	Standard uncertainty of the contribution
$(d_1+d_2)^2/4\lambda \leq \text{range length} < (d_1+d_2)^2/2\lambda$	1,26 dB
$(d_1+d_2)^2/2\lambda \leq \text{range length} < (d_1+d_2)^2/\lambda$	0,30 dB
$(d_1+d_2)^2/\lambda \leq \text{range length} < 2(d_1+d_2)^2/\lambda$	0,10 dB
$\text{range length} \geq 2(d_1+d_2)^2/\lambda$	0,00 dB

NOTE 2: In table 34,  $d_1$  and  $d_2$  are the maximum dimensions of the antennas.

NOTE 3: In this example case the standard uncertainty of the contribution due to the range length is taken as 0,00 dB since the range length is  $\geq 2(d_1+d_2)^2/\lambda$ .

**Mutual coupling: amplitude effect of the test antenna on the EUT:** This uncertainty results from the interaction between the EUT and the test antenna when placed close together. The standard uncertainty of the contribution due to the amplitude effect of the mutual coupling between the test antenna and the EUT, is designated throughout all parts of ETR 273 [12] as  $u_{j08}$ . The standard uncertainty should be taken from table 35.

**Table 35: Uncertainty contribution: Mutual coupling: amplitude effect of the test antenna on the EUT**

Range length	Standard uncertainty of the contribution
$0,62\sqrt{(d_1+d_2)^3/\lambda} \leq \text{range length} < 2(d_1+d_2)^2/\lambda$	0,50 dB
$\text{range length} \geq 2(d_1+d_2)^2/\lambda$	0,00 dB

NOTE 4: In this example case the standard uncertainty of the contribution due to the amplitude effect of the mutual coupling between the test antenna and the EUT is 0,00 dB since the distance is  $\geq 2(d_1+d_2)^2/\lambda$ .

**Mutual coupling: EUT to its images in the absorbing material:** This uncertainty is dependant on the quality of the absorbing material and the effect imaging of the EUT in the ceiling, side and end walls has on the input impedance and/or gain of the integral antenna. The standard uncertainty of the contribution, due to the mutual coupling of the EUT to its images in the absorbing material, is designated throughout all parts of ETR 273 [12] as  $u_{j04}$ .

NOTE 5: In this example case the standard uncertainty of the contribution due to the mutual coupling amplitude effect of the absorbing material on the EUT is assumed to be 0,5 dB (see annex A).

**Mutual coupling: EUT to its image in the ground plane:** This uncertainty results from the change in the EUT spurious emission level as a result of being placed close to the ground plane. The standard uncertainty of the contribution, due to the mutual coupling of the EUT to its image in the ground plane, is designated throughout all parts of ETR 273 [12] as  $u_{j13}$ . Its value can be obtained from table 36.

**Table 36: Uncertainty contribution of the mutual coupling between the EUT to its image in the ground plane**

Spacing between the EUT and the ground plane	Standard uncertainty of the contribution
<b>For a vertically polarized EUT</b>	
spacing $\leq 1,25 \lambda$	0,15 dB
spacing $> 1,25 \lambda$	0,06 dB
<b>For a horizontally polarized EUT</b>	
spacing $< \lambda/2$	1,15 dB
$\lambda/2 \leq$ spacing $< 3\lambda/2$	0,58 dB
$3\lambda/2 \leq$ spacing $< 3\lambda$	0,29 dB
spacing $\geq 3\lambda$	0,15 dB

NOTE 6: In this example case the standard uncertainty of the contribution, due to the mutual coupling of the EUT to its image in the ground plane, (assuming the polarization is vertical and the spacing above the ground plane is  $< 1,25 \lambda$  at the test frequency) is taken as 0,15 dB.

**Reflectivity of absorbing material: EUT to the test antenna.** This uncertainty is associated with the magnitudes of the reflections occurring from the side walls, end walls and ceiling. These magnitudes are a function of the quality of the absorber at the frequency of test. The standard uncertainty of the contribution, due to the reflectivity of the absorbing material between the EUT and the test antenna, is designated throughout all parts of ETR 273 [12] as  $u_{j01}$ . The relevant value for this contribution should be taken from table 37.

**Table 37: Uncertainty contribution of the reflectivity of absorbing material between the EUT and test antenna**

Reflectivity of the absorbing material	Standard uncertainty of the contribution
reflectivity $< 10$ dB	4,76 dB
$10 \leq$ reflectivity $< 15$ dB	3,92 dB
$15 \leq$ reflectivity $< 20$ dB	2,56 dB
$20 \leq$ reflectivity $< 30$ dB	1,24 dB
reflectivity $\geq 30$ dB	0,74 dB

NOTE 7: In this example case the standard uncertainty of the contribution due to the reflectivity of the absorbing material between the EUT and the test antenna is taken as 1,24 dB.

**Mutual coupling: test antenna to its images in the absorbing material:** This is the uncertainty due to the mutual coupling between the test antenna and its images in the ceiling, side and end walls and is the effect of the change produced in the antenna's input impedance and/or gain. The standard uncertainty of the contribution, due to the mutual coupling between the test antenna and its images in the absorbing material, is designated throughout all parts of ETR 273 [12] as  $u_{j06}$ .

NOTE 8: In this example case the standard uncertainty of the contribution due to the mutual coupling between the test antenna and its images in the absorbing material is taken as 0,00 dB since in this, the second stage of the measurement, the uncertainty will only contribute if the test antenna is located at a different height to the first stage which is not allowed by the methodology hence the uncertainty is assumed to be systematic i.e. it is assumed constant and common to both stages of the measurement.

**Mutual coupling: test antenna to its image in the ground plane:** This is the uncertainty due to the mutual coupling between the test antenna and its image in the ground plane and is the effect of the change produced in the antenna's input impedance and/or gain when placed close to a ground plane. The standard uncertainty of the contribution, due to the mutual coupling of the test antenna to its image in the ground plane, is designated throughout all parts of ETR 273 [12] as  $u_{j14}$ .

NOTE 9: In this example case the standard uncertainty of the contribution due to the mutual coupling of the test antenna to its image in the ground plane is taken as 0,00 dB since in this, the second stage of the measurement, the uncertainty will only contribute if the test antenna is located at a different height to the first stage which is not allowed by the methodology hence the uncertainty is assumed to be systematic i.e. it is assumed constant and common to both stages of the measurement.

#### 6.8.4.2.2.6 EUT

**EUT: mutual coupling to the power leads:** This is the uncertainty associated with the influence (reflections, parasitic effects, etc.) of the power leads on the EUT. The standard uncertainty associated with this effect is 0,5 dB provided that the precautions detailed in the methods have been observed. i.e. routing and dressing of cables with ferrites. If no prevention has been attempted the standard uncertainty is 2,0 dB. The standard uncertainty of the contribution, due to the mutual coupling of the EUT to the power leads, is designated throughout all parts of ETR 273 [12] as  $u_{j54}$ .

NOTE 1: In this example case the standard uncertainty of the contribution due to the mutual coupling of the EUT to the power leads is taken as 0,5 dB since the precautions detailed in the methods have been observed.

**Position of the phase centre: within the EUT volume:** This contribution is associated with the uncertainty with which the actual radiating point within the equipment volume is known. If this point is known exactly the contribution is 0,00 dB. The standard uncertainty of the contribution due to the position of the phase centre within the EUT volume is designated throughout all parts of ETR 273 [12] as  $u_{j20}$ .

NOTE 2: In this example case the standard uncertainty of the contribution due to the position of the phase centre within the EUT volume has been calculated from  $(\pm(\text{the maximum dimension of device})/(2 \times \text{range length}) \times 100 \%)$ . In this example the position is not known. Hence, the uncertainty of the position of the phase centre within the EUT of 0,15 m maximum dimension is  $0,15/2 \text{ m} = 0,075 \text{ m}$ , and the worst case uncertainty due to this offset is therefore  $(0,075/3,0) \times 100 \% = \pm 2,50 \%$ . As the phase centre can be anywhere inside the EUT, the uncertainty is taken as rectangularly distributed and the standard uncertainty is calculated as 1,44 %. This is then transformed to the logarithmic form  $(1,44/11,5) = 0,12 \text{ dB}$  (ETR 028 [15], part 2, annex E).

**Positioning of the phase centre: within the EUT over the axis of rotation of the turntable:** This contribution is associated with the uncertainty with which the actual radiating point within the equipment is placed over the centre of the turntable. If the point is placed exactly, the contribution is 0,00 dB. The standard uncertainty of the contribution, due to the positioning of the phase centre within the EUT over the axis of rotation of the turntable, is designated throughout all parts of ETR 273 [12] as  $u_{j21}$ .

NOTE 3: In this example case the standard uncertainty of the contribution due to the positioning of the EUT phase centre over the axis of rotation of the turntable is calculated from  $(\pm(\text{the estimated offset from the axis of rotation})/(2 \times \text{range length}) \times 100 \%)$ . In this case, the uncertainty is taken as  $\pm 0,01 \text{ m}$ , and the worst case uncertainty is  $\pm(0,01/3,0) \times 100 = \pm 0,333 \%$ . As the offset can be anywhere between the limits the uncertainty is rectangularly distributed and the standard uncertainty is calculated as 0,192 %. This is then transformed to the logarithmic form  $(0,192/11,5) = 0,02 \text{ dB}$  (ETR 028 [15], part 2, annex E).

**EUT: degradation measurement:** This contribution is a RF level uncertainty associated with the uncertainty of measuring 20 dB SINAD,  $10^{-2}$  bit stream or 80 % message acceptance ratio. The standard uncertainty of the contribution, due to the EUT degradation measurement, is designated throughout all parts of ETR 273 [12] as  $u_{j52}$ . Its value can be obtained from ETR 028 [15].

NOTE 4: In this example case, the standard uncertainty of the contribution is obtained from ETR 028 [15] and its value is 0,68 dB.

#### 6.8.4.2.3 Contribution from the random component

**Random uncertainty:** The magnitude can be assessed from multiple measurements of the receiver sensitivity. The standard uncertainty of the contribution due to the random uncertainty is designated throughout all parts of ETR 273 [12] as  $u_{j01}$ .

The receiver sensitivity measurement was repeated 10 times. The following results were obtained in dB $\mu$ V (before correcting for cabling and attenuator network insertion loss):

- 65,4; 63,4; 66,0; 65,3; 63,0; 64,9; 65,2; 66,8; 65,5; 63,7.

Converting to linear terms:

- $1,862 \times 10^{-3}$ ;  $1,479 \times 10^{-3}$ ;  $1,995 \times 10^{-3}$ ;  $1,841 \times 10^{-3}$ ;  $1,413 \times 10^{-3}$ ;  $1,758 \times 10^{-3}$ ;  $1,820 \times 10^{-3}$ ;  $2,188 \times 10^{-3}$ ;  $1,884 \times 10^{-3}$ ;  $1,531 \times 10^{-3}$ .

The two sums  $X$  and  $Y$  are calculated:

- $X$  = the sum of the measured values =  $17,77 \times 10^{-3}$ ;
- $Y$  = the sum of the squares of the measured values =  $32,10 \times 10^{-6} \text{ V}^2$ .

$$u_{c \text{ random}} = \sqrt{\frac{Y - \frac{X^2}{n}}{n-1}} = \sqrt{\frac{32,10 \times 10^{-6} - \frac{(17,77 \times 10^{-3})^2}{10}}{10-1}} = 238,3 \times 10^{-6} \text{ (formula 5.6)}$$

As the result is obtained as the mean value of 10 measurements and the standard uncertainty of the random uncertainty is:

$$u_{j \text{ random}} = \frac{238,3 \times 10^{-6}}{1,777 \times 10^{-3}} \times \frac{100}{11,5} = 1,17 \text{ dB}$$

NOTE: In this example case the standard uncertainty of the contribution due to the random uncertainty is 1,17 dB.

#### 6.8.4.2.4 Summary table of contributory components

All the uncertainty contributions for this part of the procedure are listed in table 38.

**Table 38: Contributions from the EUT measurement**

<b>u<sub>j</sub> or i</b>	<b>Description of uncertainty contributions</b>	<b>dB</b>
u <sub>j36</sub>	mismatch: transmitting part	0,00
u <sub>j38</sub>	signal generator: absolute output level	0,58
u <sub>j39</sub>	signal generator: output level stability	0,00
u <sub>j41</sub>	insertion loss: test antenna cable	0,00
u <sub>j19</sub>	cable factor: test antenna cable	0,00
u <sub>j40</sub>	insertion loss: test antenna attenuator	0,00
u <sub>j17</sub>	correction: off boresight angle in elevation plane	0,00
u <sub>j18</sub>	correction: measurement distance	0,00
u <sub>j45</sub>	antenna: gain of the test antenna	0,00
u <sub>j46</sub>	antenna: tuning of the test antenna	0,00
u <sub>j22</sub>	position of the phase centre: test antenna	0,00
u <sub>j34</sub>	ambient effect	0,00
u <sub>j08</sub>	mutual coupling: amplitude effect of the test antenna on the EUT	0,00
u <sub>j04</sub>	Mutual coupling: EUT to its images in the absorbing material	0,50
u <sub>j13</sub>	mutual coupling: EUT to its image in the ground plane	0,15
u <sub>j01</sub>	reflectivity of absorber material: EUT to the test antenna	1,24
u <sub>j06</sub>	mutual coupling: test antenna to its images in the absorbing material	0,00
u <sub>j14</sub>	mutual coupling: test antenna to its image in the ground plane	0,00
u <sub>j55</sub>	EUT: mutual coupling to the power leads	0,50
u <sub>j20</sub>	position of the phase centre: within the EUT volume	0,12
u <sub>j22</sub>	positioning of the phase centre: within the EUT over the axis of rotation of the turntable	0,02
u <sub>j16</sub>	range length	0,00
u <sub>j52</sub>	EUT: degradation measurement	0,68
u <sub>i01</sub>	random uncertainty	1,17

The standard uncertainties from table 38 should be combined by RSS in accordance with ETR 273 [12], part 1, subpart 1, clause 5. This gives the combined standard uncertainty ( $u_{c \text{ EUT measurement}}$ ) for the NSA measurement in dB.

The value of  $u_{c \text{ EUT measurement}}$  is calculated as 2,06 dB.

#### 6.8.4.2.5 Expanded uncertainty for the receiver Sensitivity measurement

The combined standard uncertainty of the results of the verification procedure is the combination of the components outlined in clauses 6.8.2.1.4 and 6.8.2.2.4. The components to be combined are  $u_{c \text{ Transform Factor}}$  and  $u_{c \text{ EUT measurement}}$

$$u_{c \text{ Sensitivity measurement}} = \sqrt{1,67^2 + 2,06^2} = 2,65 \text{ dB}$$

The expanded uncertainty is  $\pm 1,96 \times 2,65 \text{ dB} = \pm 5,19 \text{ dB}$  at a 95 % confidence level.

## 6.9 Examples of measurement uncertainty analysis (Stripline)

### 6.9.1 Introduction

This clause contains detailed worked examples of the calculation of expanded uncertainty of radiated tests in a Stripline test facility.

The example tests given are limited to:

- a verification procedure;
- the measurement of a receiver parameter (Sensitivity).

Both of the example tests are assumed to have been carried out in the 2-plate open Stripline described in CENELEC European Standard EN 55020 [16].

NOTE 1: The values given to all of the uncertainty components in these examples are only to illustrate the uncertainty calculation. In practice, values should be derived by consulting annex A.

All radiated tests consist of two stages. For the verification procedure, the first stage is to set a reference level whilst the second stage involves the measurement of path loss/attenuation through the Stripline. For the measurement of the receive sensitivity of an EUT, the first stage is to find the minimum (or average) signal generator output that produces the required receiver response, whilst the second stage determines the field strength in the Stripline corresponding to that generator output level.

Within any radiated test there are uncertainty components that are common to both stages of the test. By their different natures some of these common uncertainties will cancel (e.g. the uncertainty of the insertion loss of a cable common to both parts), others will contribute once (e.g. the increase in the field strength caused by a large EUT) whilst others may contribute twice (e.g. the level stability of a signal generator in receiver tests). In each of the following uncertainty analyses, uncertainty components common to both stages are shown as shaded areas in the accompanying schematic diagrams.

As shown in the examples, all the individual uncertainty components for any test are combined in the manner described in ETR 273 [12], part 1, subpart 1, clauses 4 and 5 in order to derive an expanded uncertainty figure for the measurement. The values of the individual components are either provided in annex A or should be taken from manufacturers' data sheets. Whenever they are obtained from data sheets, worst case figures given over a frequency band should be used. For example, in the case of a signal generator whose absolute level accuracy is quoted as  $\pm 1 \text{ dB}$  over 30 MHz to 300 MHz,  $\pm 2 \text{ dB}$  over 300 MHz to 1 000 MHz the figure for the band containing the test frequency should be used. This approach should be adopted for all uncertainty components, taking the uncertainty figures over as broad a band as possible. This is normally satisfactory when the variation with frequency is not large and provides a simple and flexible approach. The resulting expanded uncertainty figure is valid across a broad range of frequencies and measurement conditions and avoids the necessity of repeated calculation for minor frequency changes.

NOTE 2: Taking specific frequency values may result in a lower expanded uncertainty value, but this lower value is only valid when that specific set of circumstances apply for which the value was derived.

### 6.9.2 Example 1: Verification procedure

The Stripline verification procedure involves two different measurement stages and it results in values for both the attenuation through the Stripline and its Transform Factor (i.e. the relationship between the input voltage to the Stripline and the resulting field strength between the plates).

### 6.9.2.1 Uncertainty contributions: Stage 1: Direct attenuation measurement

The first stage of the verification procedure is the direct attenuation measurement. This is carried out with all the items of test equipment connected directly together via an "in line" adapter between the attenuators as shown in figure 33. The components shown shaded are common to both stages of the procedure.

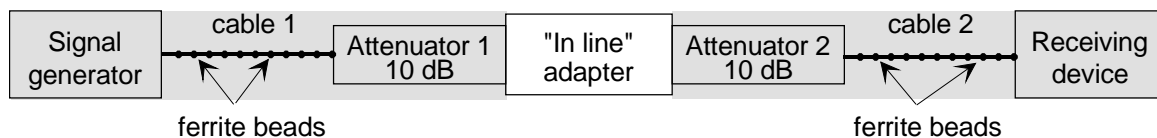

**Figure 33: Stage 1: Direct attenuation measurement**

Despite the commonality of most of the components to both stages of this procedure, the mismatch uncertainty contribution for both stages has to be calculated and included in the uncertainty calculations. This is the result of load conditions varying (i.e. the Stripline and monopole replaces the adapter in the second stage). Conversely, as a result of this commonality, the uncertainty contributions of some of the individual components will cancel.

Whereas figure 33 shows, schematically, the test equipment set-up for this stage of the verification procedure, an analysis diagram of the individual components (each of which contributes its own uncertainty) for this stage of the measurement is shown in figure 34. Again, as stated above, the shaded areas represent components common to both stages of the verification procedure.

#### 6.9.2.1.1 Contributions from the mismatch components

**Mismatch: direct attenuation measurement:** The value of the combined standard uncertainty of the contribution due to the mismatch from the source to the receptor, i.e. between the signal generator and the receiving device, is calculated from the approach described in annex G. All the individual contributions are U-distributed.

NOTE 1: In this example the signal generator output reflection coefficient used is the worst case magnitude over the frequency band of interest, as is the case with the cable, adapter and attenuator VSWRs.

NOTE 2: The attenuation values of the cables and attenuators should be obtained from the manufacturers data sheet/calibration records at the specific frequency of the test, along with the associated uncertainties for these values.

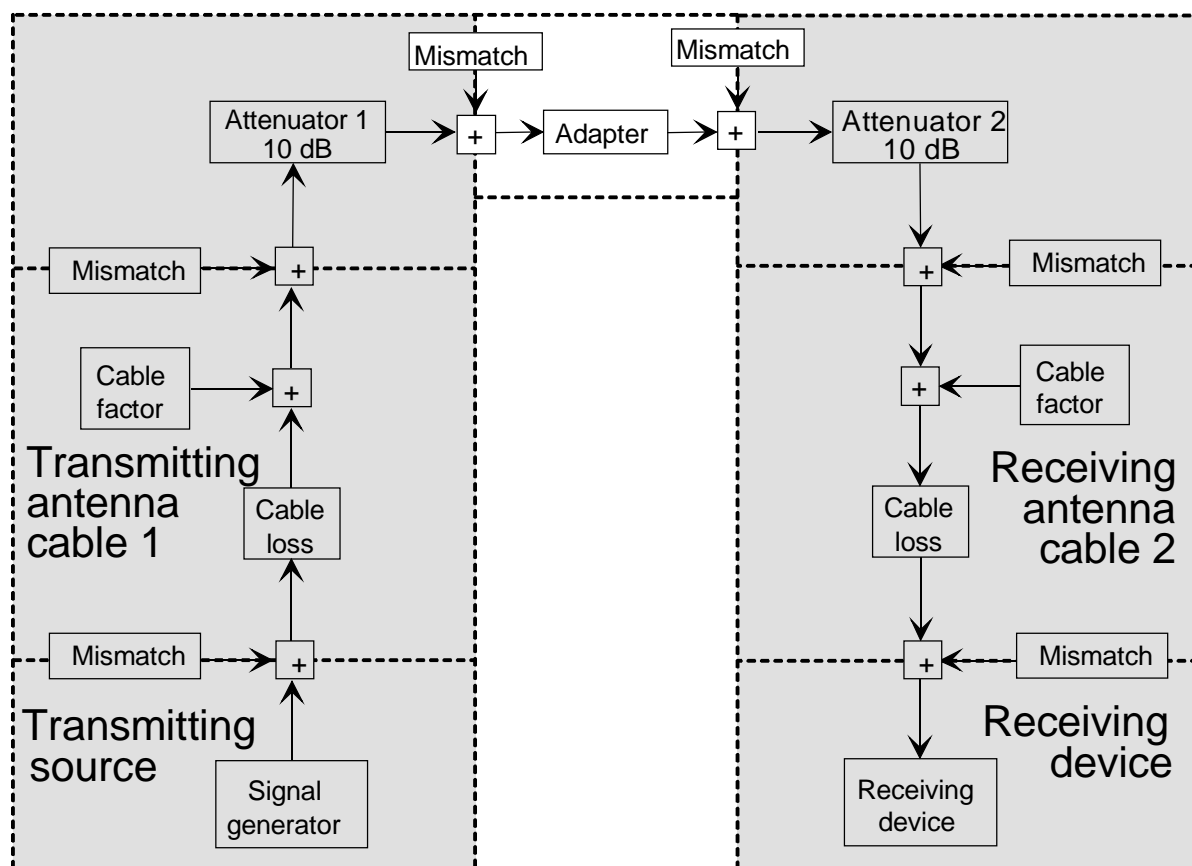

Figure 34: Stage 1: Direct attenuation measurement individual uncertainty components

Signal generator:	Output reflection coefficient: $ \rho_G $	= 0,20
Cable:	Input and output reflection coefficients: $ S_{11}  =  S_{22} $	= 0,07
	Attenuation: 1 dB = $ S_{12}  =  S_{21} $	= 0,891
Attenuator:	Input and output reflection coefficients $ S_{11}  =  S_{22} $	= 0,05
	Attenuation = 10 dB $ S_{12}  =  S_{21} $	= 0,3162
Adapter:	Input and output reflection coefficients $ S_{11}  =  S_{22} $	= 0,02
	Attenuation = 0,1 dB $ S_{12}  =  S_{21} $	= 0,9886
Attenuator:	Input and output reflection coefficients $ S_{11}  =  S_{22} $	= 0,05
	Attenuation = 10 dB $ S_{12}  =  S_{21} $	= 0,3162
Cable:	Input and output reflection coefficients: $ S_{11}  =  S_{22} $	= 0,07
	Attenuation: 1 dB = $ S_{12}  =  S_{21} $	= 0,891
Receiving device:	Input reflection coefficient: $ \rho_{RD} $	= 0,20

**Mismatch uncertainty in the direct attenuation measurement:** In the following the transmitting antenna cable is named cable 1, the transmitting antenna attenuator is named attenuator 1, the receiving antenna cable is named cable 2, the receiving attenuator is named attenuator 2. Those components that are constant for both stages 1 and 2 are not calculated as they do not contribute to the overall uncertainty.

Mismatch between:

- $u_{j \text{ generator and cable 1}}$ : Constant for both stage 1 and 2. Hence this value does not contribute.
- $u_{j \text{ cable 1 and attenuator 1}}$ : Constant for both stage 1 and 2. Hence this value does not contribute.

$$u_{j \text{ mismatch:attenuator1and adapter}} = \frac{0,05 \times 0,02 \times 100}{\sqrt{2}} \% = 0,071 \%$$

$$u_{j \text{ mismatch:adapterand attenuator1}} = \frac{0,02 \times 0,05 \times 100}{\sqrt{2}} \% = 0,071 \%$$

- $u_{j \text{ attenuator 2 and cable 2}}$ : Constant for both stage 1 and 2. Hence this value does not contribute.
- $u_{j \text{ cable 2 and receiving device}}$ : Constant for both stage 1 and 2. Hence this value does not contribute.
- $u_{j \text{ generator and attenuator 1}}$ : Constant for both stage 1 and 2. Hence this value does not contribute.

$$u_{j \text{ mismatch:cable1and adapter}} = \frac{0,07 \times 0,07 \times 0,316^2 \times 100}{\sqrt{2}} \% = 0,035 \%$$

$$u_{j \text{ mismatch:attenuator1and attenuator2}} = \frac{0,05 \times 0,05 \times 0,988^2 \times 100}{\sqrt{2}} \% = 0,173 \%$$

$$u_{j \text{ mismatch:adapterand cable2}} = \frac{0,02 \times 0,07 \times 0,316^2 \times 100}{\sqrt{2}} \% = 0,010 \%$$

- $u_{j \text{ attenuator 2 and receiving device}}$ : Constant for both stage 1 and 2. Hence this value does not contribute.

$$u_{j \text{ mismatch:generatorand adapter}} = \frac{0,2 \times 0,02 \times 0,891^2 \times 0,316^2 \times 100}{\sqrt{2}} \% = 0,022 \%$$

$$u_{j \text{ mismatch:cable1and attenuator2}} = \frac{0,07 \times 0,05 \times 0,316^2 \times 0,988^2 \times 100}{\sqrt{2}} \% = 0,024 \%$$

$$u_{j \text{ mismatch:attenuator1and cable2}} = \frac{0,05 \times 0,07 \times 0,988^2 \times 0,316^2 \times 100}{\sqrt{2}} \% = 0,024 \%$$

$$u_{j \text{ mismatch:adapterand receiving device}} = \frac{0,02 \times 0,2 \times 0,316^2 \times 0,891^2 \times 100}{\sqrt{2}} \% = 0,022 \%$$

$$u_{j \text{ mismatch:generatorand attenuator2}} = \frac{0,2 \times 0,05 \times 0,891^2 \times 0,316^2 \times 0,988^2 \times 100}{\sqrt{2}} \% = 0,055 \%$$

- $u_{j \text{ mismatch: cable 1 and cable 2}}$ : Less than 0,01 % due to the two attenuators, therefore neglected.

$$u_{j \text{ mismatch:attenuator1and receiving device}} = \frac{0,05 \times 0,2 \times 0,988^2 \times 0,316^2 \times 0,891^2 \times 100}{\sqrt{2}} \% = 0,055 \%$$

- $u_{j \text{ mismatch: generator and cable 2}}$ : Less than 0,01 % due to the two attenuators, therefore neglected.
- $u_{j \text{ mismatch: cable 1 and receiving device}}$ : Less than 0,01 % due to the two attenuators, therefore neglected.
- $u_{j \text{ mismatch: generator and receiving device}}$ : Less than 0,01 % due to the two attenuators, therefore neglected.



The combined standard uncertainty of the mismatch is then calculated:

$$u_{cmismatch:directatt.} = \sqrt{0,071^2 + 0,071^2 + \dots + 0,055^2 + 0,055^2} = 0,306 \%$$

Transforming to logarithmic form (ETR 028 [15], part 2, annex E):  $0,306 \%/11,5 = 0,026$  dB.

The standard uncertainty of the contribution, due to the mismatch in the direct attenuation measurement, is designated throughout all parts of ETR 273 [12] as  $u_{j35}$ . Its value in this example is 0,026 dB.

### 6.9.2.1.2 Contributions from individual components

#### 6.9.2.1.2.1 Signal generator

**Signal generator: absolute output level:** In a verification procedure, the signal generator's absolute level uncertainty contributes equally to both stages of the measurement. The standard uncertainty of the contribution due to the signal generator absolute output level uncertainty is designated throughout all parts of ETR 273 [12] as  $u_{j38}$ .

NOTE 1: In this example case the standard uncertainty of the contribution due to the signal generator absolute output level uncertainty is taken to be 0,00 dB since, once the level has been set in stage one of the procedure, the level is not further adjusted. The uncertainty is therefore assumed to be systematic i.e. it produces the same offset in both stages.

**Signal generator: output level stability:** In any test in which the contribution of the absolute level uncertainty of the signal generator contributes to the combined standard uncertainty of the test i.e. it does not cancel due to the methodology, the contribution from the output level stability is considered to have been included in the signal generator absolute output level,  $u_{j38}$ . Conversely, for any level in which the absolute level uncertainty of the signal generator does not contribute to the combined standard uncertainty, the output level stability of the signal generator should be included. The standard uncertainty of the contribution due to the signal generator output level stability is designated throughout all parts of ETR 273 [12] as  $u_{j39}$ . Its value can be derived from manufacturers' data sheet.

NOTE 2: In this example case the uncertainty of the contribution due to the signal generator output level stability is obtained from the manufacturers data sheet as  $\pm 0,02$  dB. As nothing is said about the distribution of this uncertainty, a rectangular distribution (see ETR 273 [12], part 1, subpart 1, clause 5.1.2) in logs is assumed, and the standard uncertainty is calculated as 0,01155 dB. This is rounded down to 0,01 dB.

#### 6.9.2.1.2.2 Signal generator cable

**Insertion loss: signal generator cable:** The signal generator cable has an insertion loss as well as an uncertainty associated with the measurement of its magnitude. The value of insertion loss and its uncertainty remain valid provided the cable is not used outside the manufacturer's specification. At any given frequency the insertion loss acts as a systematic offset and contributes equally to both stages of the measurement. The standard uncertainty of the contribution due to the insertion loss uncertainty of the signal generator cable is designated throughout all parts of ETR 273 [12] as  $u_{j41}$ .

NOTE 1: In this example case the standard uncertainty of the contribution due to the insertion loss uncertainty of the transmitting antenna cable is taken as 0,00 dB since the uncertainty is systematic i.e. it produces the same offset in both stages.

**Cable factor: signal generator cable:** Cable factor is defined as the total effect of the signal generator cable's influence on the measuring system including its interaction with the Stripline. It consists of the leakage caused by cable screening inefficiency and introducing an unbalanced current into the Stripline. In a radiated measurement the standard uncertainty of the cable factor, associated with each cable, is 0,5 dB provided that the precautions detailed in the methods have been observed. i.e. routing and dressing of cables with ferrites. If no prevention has been attempted the standard uncertainty is 4,0 dB (justification for these values is given in ETR 273 [12], part 1, subpart 2, annex E). The standard uncertainty of the contribution due to the cable factor of the signal generator cable is designated throughout all parts of ETR 273 [12] as  $u_{j19}$ .

NOTE 2: In this example case the standard uncertainty of the contribution due to the cable factor of the signal generator is taken as 0,00 dB since there are no external fields involved other than leakage, which is assumed to have a negligible effect on the measurement.

### 6.9.2.1.2.3 Signal generator attenuator

**Insertion loss: signal generator attenuator:** The signal generator attenuator has an insertion loss as well as an uncertainty associated with the measurement of its magnitude. The value of insertion loss and its uncertainty remain valid provided the attenuator is not used outside the manufacturer's specification. At any given frequency the insertion loss acts as a systematic offset and contributes equally to both stages of the measurement. The standard uncertainty of the contribution, due to the insertion loss uncertainty of the signal generator attenuator, is designated throughout all parts of ETR 273 [12] as  $u_{j40}$ .

NOTE: In this example case the standard uncertainty of the contribution due to the insertion loss uncertainty of the signal generator attenuator is taken as 0,00 dB since the uncertainty is systematic i.e. it produces the same offset in both stages.

### 6.9.2.1.2.4 Adapter

**Insertion loss: adapter:** The adapter has an insertion loss as well as an uncertainty associated with the measurement of its magnitude. The value of insertion loss and its uncertainty remain valid provided the adapter is not used outside the manufacturer's specification. The standard uncertainty of the contribution due to the insertion loss uncertainty of the adapter is designated throughout all parts of ETR 273 [12] as  $u_{j42}$ . Its value can be derived from the manufacturer's data sheet.

NOTE: In this example case the uncertainty of the contribution due to the insertion loss uncertainty of the adapter is obtained from the manufacturer's data sheet as  $\pm 0,10$  dB. As nothing is said about the distribution of this uncertainty, a rectangular distribution (see ETR 273 [12], part 1, subpart 1, clause 5.1.2) in logs is assumed, and the standard uncertainty is calculated as 0,06 dB.

### 6.9.2.1.2.5 Receiving device attenuator

**Insertion loss: receiving device attenuator:** The attenuator has an insertion loss as well as an uncertainty associated with the measurement of its magnitude. The value of insertion loss and its uncertainty remain valid provided the attenuator is not used outside the manufacturer's specification. At any given frequency the insertion loss acts as a systematic offset and contributes equally to both stages of the measurement. The standard uncertainty of the contribution due to the insertion loss uncertainty of the receiving device attenuator is designated throughout all parts of ETR 273 [12] as  $u_{j40}$ .

NOTE: In this example case the standard uncertainty of the contribution due to the insertion loss uncertainty of the receiving device attenuator is taken as 0,00 dB since the uncertainty is systematic i.e. it produces the same offset in both stages.

### 6.9.2.1.2.6 Receiving device cable

**Insertion loss: receiving device cable:** The receiving device cable has an insertion loss as well as an uncertainty associated with the measurement of its magnitude. The value of insertion loss and its uncertainty remain valid provided the cable is not used outside the manufacturer's specification. At any given frequency the insertion loss acts as a systematic offset and contributes equally to both stages of the measurement. The standard uncertainty of the contribution, due to the insertion loss uncertainty of the receiving device cable, is designated throughout all parts of ETR 273 [12] as  $u_{j41}$ .

NOTE 1: In this example case the standard uncertainty of the contribution due to the insertion loss uncertainty of the receiving device cable is taken as 0,00 dB since the uncertainty is systematic i.e. it produces the same offset in both stages.

**Cable factor: receiving device cable:** Cable factor is defined as the total effect of the receiving device cable's influence on the measuring system including its interaction with the Stripline. It consists of the leakage caused by cable screening inefficiency and introducing an unbalanced current into the Stripline. In a radiated measurement the standard uncertainty of the cable factor, associated with each cable, is 0,5 dB provided that the precautions detailed in the methods have been observed i.e. routing and dressing of cables with ferrites. If no prevention has been attempted the standard uncertainty is 4,0 dB (justification for these values is given in ETR 273 [12], part 1, subpart 2, annex E). The standard uncertainty of the contribution due to the cable factor of the receiving device cable is designated throughout all parts of ETR 273 [12] as  $u_{j19}$ .

NOTE 2: In this example case the standard uncertainty of the contribution due to the cable factor of the receiving device cable is taken as 0,00 dB since there are no external fields involved other than leakage, which is assumed to have a negligible effect on the measurement.

#### 6.9.2.1.2.7 Receiving device

In this, the first stage of the Stripline verification procedure, a reference level is set on the receiving device for a particular output level from the signal generator. In the second stage (where the path loss through the Stripline is measured), a second level is obtained on the receiving device. Only in the second stage do the linearity and absolute level uncertainties of the receiver become involved in the calculation of the combined standard uncertainty for the measurement.

**Receiving device: absolute level:** The standard uncertainty of the contribution due to the receiving device absolute level uncertainty is designated throughout all parts of ETR 273 [12] as  $u_{j47}$ .

NOTE 1: In this example case the standard uncertainty of the contribution due to the absolute level uncertainty of the receiving device is assumed to be 0,00 dB since, in this part of the measurement, a reference level is recorded.

**Receiving device: linearity:** The standard uncertainty of the contribution due to the receiving device linearity is designated throughout all parts of ETR 273 [12] as  $u_{j48}$ .

NOTE 2: In this example case the standard uncertainty of the contribution due to the receiving device linearity is assumed to be 0,00 dB since, in this part of the measurement, a reference level is recorded.

#### 6.9.2.1.3 Contribution from the random component

**Random uncertainty:** The magnitude can be assessed from multiple measurements of the direct attenuation measurement. The standard uncertainty of the contribution due to the random uncertainty is designated throughout all parts of ETR 273 [12] as  $u_{i01}$ . Its value can then be calculated.

The direct attenuation measurement was repeated 10 times. The following results (dB $\mu$ V) in were obtained (before correcting for cabling and attenuator network insertion loss):

- 106,8; 107,2; 106,7; 107,0; 107,2; 106,7; 107,1; 106,8; 107,1; 107,0.

Converting to linear terms:

- 0,2188; 0,2291; 0,2163; 0,2239; 0,2291; 0,2163; 0,2265; 0,2188; 0,2265; 0,2239.

The two sums  $X$  and  $Y$  are calculated:

- $X$  = the sum of the measured values = 2,2292 V;
- $Y$  = the sum of the squares of the measured values = 0,4972 V<sup>2</sup>.

$$u_{c\ random} = \sqrt{\frac{Y - \frac{X^2}{n}}{n-1}} = \sqrt{\frac{0,4972 - \frac{2,2292^2}{10}}{10-1}} = 5,444 \times 10^{-3} \text{ (formula 5.6)}$$

As the result is obtained as the mean value of 10 measurements and the standard uncertainty of the random uncertainty is:

$$u_{j\ random} = \frac{5,444 \times 10^{-3}}{0,22292} \times \frac{100}{11,5} = 0,212 \text{ dB}$$

NOTE: In this example case the standard uncertainty of the contribution due to the random uncertainty is 0,212 dB.

#### 6.9.2.1.4 Summary table of contributory components

A complete list of all the contributions to this part of the verification procedure is given in table 39.

**Table 39: Contributions from the reference, direct measurement**

$u_j$ or $i$	Description of uncertainty contributions	dB
$U_{j35}$	mismatch: direct attenuation measurement	0,03
$U_{j38}$	signal generator: absolute output level	0,00
$U_{j39}$	signal generator: output level stability	0,01
$U_{j41}$	insertion loss: signal generator cable	0,00
$U_{j19}$	cable factor: signal generator cable	0,00
$U_{j40}$	insertion loss: signal generator attenuator	0,00
$U_{j42}$	insertion loss: adapter	0,06
$U_{j40}$	insertion loss: receiving device attenuator	0,00
$U_{j41}$	insertion loss: receiving device cable	0,00
$U_{j19}$	cable factor: receiving device cable	0,00
$U_{j47}$	receiving device: absolute level	0,00
$U_{j48}$	receiving device: linearity	0,00
$U_{i01}$	random uncertainty	0,21

The standard uncertainties from table 39 should be combined by RSS in accordance with ETR 273 [12], part 1, subpart 1, clause 5. This gives the combined standard uncertainty ( $u_{c \text{ direct attenuation measurement}}$ ) for the direct attenuation measurement in dB.

The value of  $u_{c \text{ direct attenuation measurement}}$  is calculated as 0,223 dB.

#### 6.9.2.2 Uncertainty contributions: Stage 2: Radiated attenuation measurement

The second stage of the verification procedure is the Stripline radiated attenuation measurement. This involves mounting a monopole antenna through a hole in the lower plate of the Stripline, so that the feed point to the monopole is flush with the surface of the lower plate. The radiated attenuation measurement is carried out by removing the adapter and connecting the signal generator attenuator to the Stripline and connecting the receiving device attenuator to the monopole output (figure 35). The difference in received levels (after allowance for any correction factors which may be appropriate), for the same signal generator output level, is the Stripline radiated attenuation.

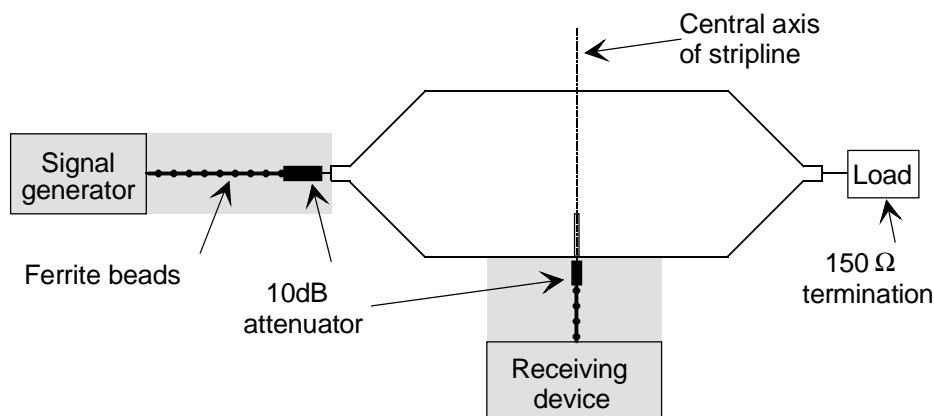
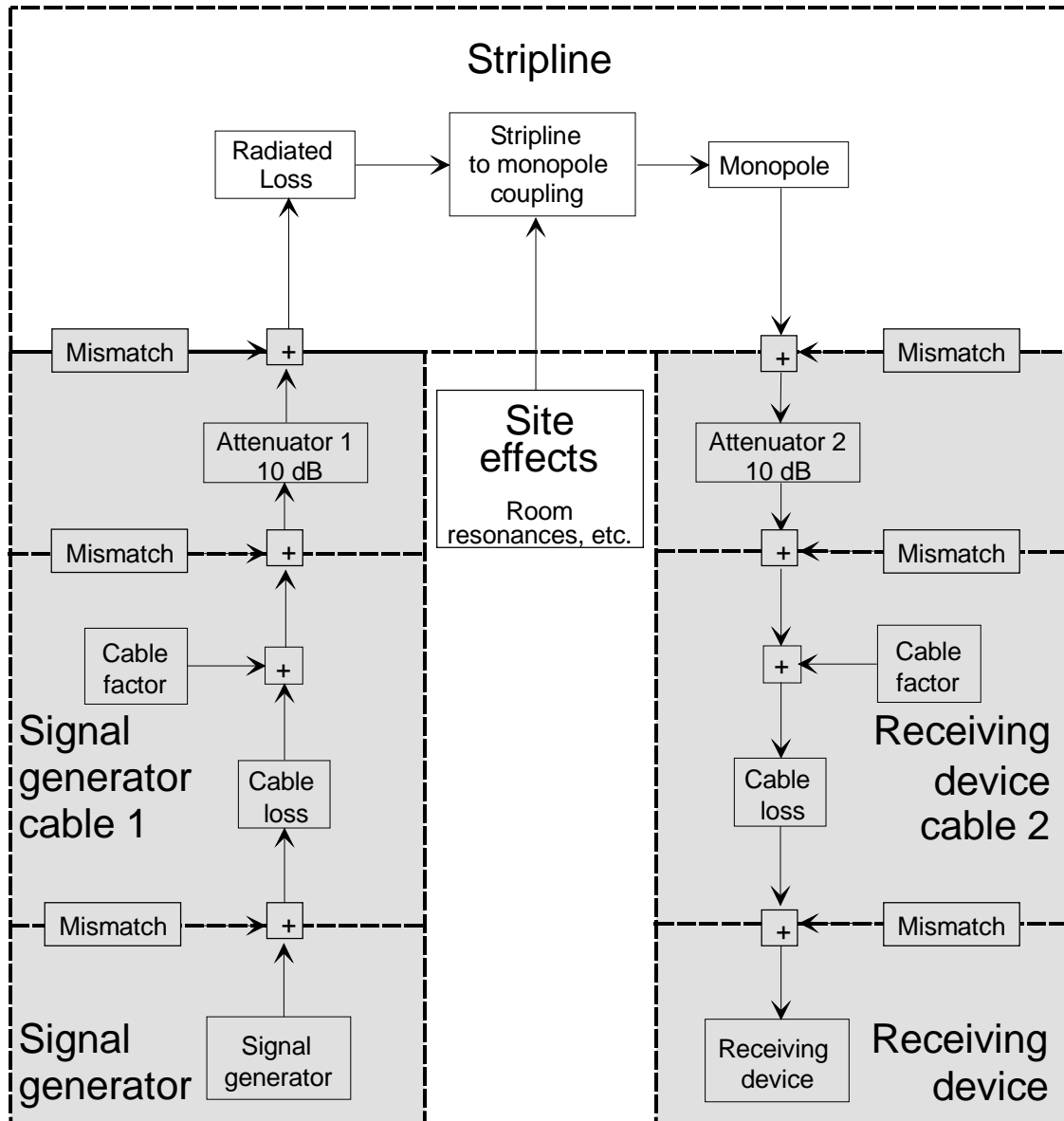

**Figure 35: Stage 2: Radiated attenuation measurement**

Whereas figure 35 shows, schematically, the test equipment set-up for this stage of the verification procedure, an analysis diagram of the individual components (each of which contributes its own uncertainty) for this stage of the measurement is shown in figure 36. Again, as stated above, the shaded areas represent components common to both stages of the verification procedure.

## 6.9.2.2.1 Contributions from the mismatch components

**Mismatch in the transmitting and receiving parts:** The value of the combined standard uncertainty of the contributions due to the mismatch are calculated from the approach described in annex G. It is calculated in two parts. Firstly the standard uncertainty of the contribution due to the mismatch in the transmitting part, i.e. between the signal generator, cable, attenuator and the input to the Stripline and secondly, that for the receiving part, i.e. between the receiving monopole antenna, attenuator, cable and the receiving device.



**Figure 36: Stage 2: Radiated attenuation measurement**

All the individual contributions are U-distributed.

NOTE 1: In this example value taken for the signal generator output reflection coefficient is the worst case over the frequency band of interest, similarly, for the cable, adapter and attenuator VSWRs.

NOTE 2: The attenuation values of the cables and attenuators should be obtained from the data sheets/calibration records at the specific frequency of the test, along with the associated uncertainties for these values.

**Mismatch: transmitting part:**

Signal generator:	Output reflection coefficient: $ \rho_G $	= 0,20
Cable:	Input and output reflection coefficients: $ S_{11} $ and $ S_{22} $	= 0,07
	Attenuation: 1 dB = $ S_{12}  =  S_{21} $	= 0,891
Attenuator:	Input and output reflection coefficients $ S_{11}  =  S_{22} $	= 0,05
	Attenuation = 10 dB $ S_{12}  =  S_{21} $	= 0,3162
Stripline:	Input reflection coefficient: $ \rho_{SL} $	= 0,333

Those components that cancel are not calculated. Other contributions are (see annex G):

- $u_{j \text{ mismatch: generator and cable } 1}$ : Constant for both stage 1 and 2. Hence this value does not contribute.
- $u_{j \text{ mismatch: cable 1 and attenuator } 1}$ : Constant for both stage 1 and 2. Hence this value does not contribute.

$$u_{j \text{ mismatch:attenuator1and Stripline}} = \frac{0,05 \times 0,333 \times 100}{\sqrt{2}} \% = 1,177\%$$

- $u_{j \text{ generator and attenuator } 1}$ : Constant for both stage 1 and 2. Hence this value does not contribute.

$$u_{j \text{ mismatch:cable1and Stripline}} = \frac{0,07 \times 0,333 \times 0,316^2 \times 100}{\sqrt{2}} \% = 0,165\%$$

$$u_{j \text{ mismatch:generatorand Stripline}} = \frac{0,2 \times 0,333 \times 0,891^2 \times 0,316^2 \times 100}{\sqrt{2}} \% = 0,373\%$$

The combined standard uncertainty of the mismatch is then calculated:

$$u_{c \text{ mismatch:transmitting part}} = \sqrt{1,177^2 + 0,165^2 + 0,373^2} = 1,25\%$$

transforming to the logarithmic form (ETR 028 [15], part 2, annex E):  $1,25 \% / 11,5 = 0,11$  dB.

The standard uncertainty of the contribution due to the mismatch in the transmitting part, is designated throughout all parts of ETR 273 [12] as  $u_{j36}$ . Its value in this example is 0,11 dB.

**Mismatch: receiving part:**

Monopole:	Input reflection coefficient: $ \rho_M $	= 0,333
Attenuator:	Input and output reflection coefficients $ S_{11}  =  S_{22} $	= 0,05
	Attenuation = 10 dB $ S_{12}  =  S_{21} $	= 0,3162
Cable:	Input and output reflection coefficients: $ S_{11} $ and $ S_{22} $	= 0,07
	Attenuation: 1 dB = $ S_{12}  =  S_{21} $	= 0,891
Receiving device:	Output reflection coefficient: $ \rho_{RD} $	= 0,20

$$u_{j \text{ mismatch:monopoleandattenuator}} = \frac{0,333 \times 0,05 \times 100}{\sqrt{2}} \% = 1,177\%$$

- $u_{j \text{ attenuator 2 and cable } 2}$ : Constant for both stage 1 and 2. Hence this value does not contribute.
- $u_{j \text{ cable 2 and receiving device}}$ : Constant for both stage 1 and 2. Hence this value does not contribute.

$$u_{jmismatch:monopoleandcable2} = \frac{0,333 \times 0,07 \times 0,316^2 \times 100}{\sqrt{2}} \% = 0,165\%$$

- $u_{jattenuator\ 2\ and\ receiving\ device}$ : Constant for both stage 1 and 2. Hence this value does not contribute.

$$u_{jmismatch:monopoleand\ receiving\ device} = \frac{0,333 \times 0,2 \times 0,316^2 \times 0,891^2 \times 100}{\sqrt{2}} \% = 0,373\%$$

The combined standard uncertainty of the mismatch is then calculated:

$$u_{cmismatch:receiving\ part} = \sqrt{1,177^2 + 0,165^2 + 0,373^2} = 1,25\%$$

Transforming to the logarithmic form (ETR 028 [15], part 2, annex E):  $1,25\% / 11,5 = 0,11\text{ dB}$ .

The standard uncertainty of the contribution due to the mismatch in the receiving part is designated throughout all parts of ETR 273 [12] as  $u_{j37}$ . Its value in this example is 0,11 dB.

#### 6.9.2.2.2 Contributions from individual components

##### 6.9.2.2.2.1 Signal generator

**Signal generator: absolute output level:** In a verification procedure, the signal generator's absolute level uncertainty contributes equally to both stages of the measurement. The standard uncertainty of the contribution due to the signal generator absolute output level uncertainty is designated throughout all parts of ETR 273 [12] as  $u_{j38}$ .

NOTE 1: In this example case the standard uncertainty of the contribution due to the signal generator absolute output level uncertainty is taken to be 0,00 dB since, once the level has been set in stage one of the procedure, the level is not further adjusted. The uncertainty is therefore assumed to be systematic i.e. it produces the same offset in both stages.

**Signal generator: output level stability:** In any test in which the contribution of the absolute level uncertainty of the signal generator contributes to the combined standard uncertainty of the test i.e. it does not cancel due to the methodology, the contribution from the output level stability is considered to have been included in the signal generator absolute output level,  $u_{j38}$ . Conversely, for any level in which the absolute level uncertainty of the signal generator does not contribute to the combined standard uncertainty, the output level stability of the signal generator should be included. The standard uncertainty of the contribution due to the signal generator output level stability is designated throughout all parts of ETR 273 [12] as  $u_{j39}$ . Its value can be derived from manufacturers' data sheet.

NOTE 2: In this example case the uncertainty of the contribution due to the signal generator output level stability is obtained from the manufacturers data sheet as  $\pm 0,02\text{ dB}$ . As nothing is said about the distribution of this uncertainty, a rectangular distribution (see ETR 273 [12], part 1, subpart 1, clause 5.1.2) in logs is assumed, and the standard uncertainty is calculated as 0,01155 dB. This is rounded down to 0,01 dB.

##### 6.9.2.2.2.2 Signal generator cable

**Insertion loss: signal generator cable:** The signal generator cable has an insertion loss as well as an uncertainty associated with the measurement of its magnitude. The value of insertion loss and its uncertainty remain valid provided the cable is not used outside the manufacturer's specification. At any given frequency the insertion loss acts as a systematic offset and contributes equally to both stages of the measurement. The standard uncertainty of the contribution, due to the insertion loss uncertainty of the signal generator cable, is designated throughout all parts of ETR 273 [12] as  $u_{j41}$ .

NOTE 1: In this example case the standard uncertainty of the contribution due to the insertion loss uncertainty of the signal generator cable is taken as 0,00 dB since the uncertainty is systematic i.e. it produces the same offset in both stages.

**Cable factor: signal generator cable:** Cable factor is defined as the total effect of the signal generator cable's influence on the measuring system including its interaction with the Stripline. It consists of the leakage caused by cable screening inefficiency and introducing an unbalanced current into the Stripline. In a radiated measurement the standard uncertainty of the cable factor, associated with each cable, is 0,5 dB provided that the precautions detailed in the methods have been observed. i.e. routing and dressing of cables with ferrites. If no prevention has been attempted the standard uncertainty is 4,0 dB (justification for these values is given in ETR 273 [12], part 1, subpart 2, annex E). The standard uncertainty of the contribution due to the cable factor of the signal generator cable is designated throughout all parts of ETR 273 [12] as  $u_{j19}$ .

NOTE 2: In this example case the standard uncertainty of the contribution due to the cable factor of the transmitting antenna cable is taken as 0,50 dB since the precautions detailed in the methods are assumed to have been observed.

#### 6.9.2.2.2.3 Signal generator attenuator

**Insertion loss: signal generator attenuator:** The signal generator attenuator has an insertion loss as well as an uncertainty associated with the measurement of its magnitude. The value of insertion loss and its uncertainty remain valid provided the attenuator is not used outside the manufacturer's specification. At any given frequency the insertion loss acts as a systematic offset and contributes equally to both stages of the measurement. The standard uncertainty of the contribution, due to the insertion loss uncertainty of the signal generator attenuator, is designated throughout all parts of ETR 273 [12] as  $u_{j40}$ .

NOTE: In this example case the standard uncertainty of the contribution due to the insertion loss uncertainty of the signal generator attenuator is taken as 0,00 dB since the uncertainty is systematic i.e. it produces the same offset in both stages.

#### 6.9.2.2.2.4 Site factors

**Ambient effect:** Uncertainty is introduced as a result of local ambient signals raising the noise floor at the measurement frequency. The standard uncertainty of the contribution due to the ambient effect is designated throughout all parts of ETR 273 [12] as  $u_{j34}$ . The values of the standard uncertainty should be taken from table 40.

**Table 40: Uncertainty contribution: Ambient effect**

Receiving device noise floor (generator OFF) is within:	Standard uncertainty of the contribution
3 dB of measurement	1,57 dB
3 dB to 6 dB of measurement	0,80 dB
6 dB to 10 dB of measurement	0,30 dB
10 dB to 20 dB of measurement	0,10 dB
20 dB or more of the measurement	0,00 dB

NOTE 1: In this example case the standard uncertainty of the contribution due to the ambient effect is taken as 0,00 dB since the Stripline is assumed to be placed in a shielded room.

**Stripline: influence of site effects:** The influence of site effects comprise those effects resulting from not observing the recommendations given in EN 55020 [16] regarding positioning of the Stripline and layout of the absorber. These can lead to incorrect received levels i.e. values which differ from theoretical calculations. The standard uncertainty of the contribution due to the influence of site effects is designated throughout all parts of ETR 273 [12] as  $u_{j33}$ .

NOTE 2: In this example case the standard uncertainty of the contribution due to the influence of site effects is taken to have a standard uncertainty of 3,0 dB (see annex A). In the verification procedure, site effects only contribute to the Stripline radiated attenuation part.



#### 6.9.2.2.2.5 Antenna factor of the monopole

**Stripline: antenna factor of the monopole:** This has been derived from measurements taken within the Stripline. Therefore, the given values incorporate several of the field disturbance factors which the Stripline possesses and which therefore do not have to be allowed for as individual contributions. Amongst these included effects are imaging, characteristic impedance of the line, non-planar nature of the field etc. The standard uncertainty of the contribution due to the antenna factor of the monopole is designated throughout all parts of ETR 273 [12] as  $u_{j30}$ .

NOTE: In this example case the standard uncertainty of the contribution due to the antenna factor of the monopole is taken as 1,15 dB. This combined uncertainty source is only present in the Stripline radiated attenuation measurement.

#### 6.9.2.2.2.6 Receiving device attenuator

**Insertion loss: receiving device attenuator:** The receiving device attenuator has an insertion loss as well as an uncertainty associated with the measurement of its magnitude. The value of insertion loss and its uncertainty remain valid provided the attenuator is not used outside the manufacturer's specification. At any given frequency the insertion loss acts as a systematic offset and contributes equally to both stages of the measurement. The standard uncertainty of the contribution due to the insertion loss uncertainty of the receiving device attenuator is designated throughout all parts of ETR 273 [12] as  $u_{j40}$ .

NOTE: In this example case the standard uncertainty of the contribution due to the insertion loss uncertainty of the receiving device attenuator is taken as 0,00 dB since the uncertainty is systematic i.e. it produces the same offset in both stages.

#### 6.9.2.2.2.7 Receiving device cable

**Insertion loss: receiving device cable:** The receiving device cable has an insertion loss as well as an uncertainty associated with the measurement of its magnitude. The value of insertion loss and its uncertainty remain valid provided the cable is not used outside the manufacturer's specification. At any given frequency the insertion loss acts as a systematic offset and contributes equally to both stages of the measurement. The standard uncertainty of the contribution, due to the insertion loss uncertainty of the receiving device cable, is designated throughout all parts of ETR 273 [12] as  $u_{j41}$ .

NOTE 1: In this example case the standard uncertainty of the contribution due to the insertion loss uncertainty of the receiving device cable is taken as 0,00 dB since the uncertainty is systematic i.e. it produces the same offset in both stages.

**Cable factor: receiving device cable:** Cable factor is defined as the total effect of the receiving device cable's influence on the measuring system including its interaction with the site. It consists of the leakage caused by cable screening inefficiency and introducing an unbalanced current into the monopole. In a radiated measurement the standard uncertainty of the cable factor, associated with each cable, is 0,5 dB provided that the precautions detailed in the methods have been observed i.e. routing and dressing of cables with ferrites. If no prevention has been attempted the standard uncertainty is 4,0 dB (justification for these values is given in ETR 273 [12], part 1, subpart 2, annex E). The standard uncertainty of the contribution due to the cable factor of the receiving device cable is designated throughout all parts of ETR 273 [12] as  $u_{j19}$ .

NOTE 2: In this example case the standard uncertainty of the contribution due to the cable factor of the receiving antenna cable is taken as 0,50 dB since the precautions detailed in the methods have been observed.

#### 6.9.2.2.2.8 Receiving device

The first stage of the verification procedure involved setting a reference level on the receiving device for a particular output level from the signal generator. In this the second stage (where the radiated attenuation through the Stripline is measured), a second level is obtained which results in linearity and absolute level uncertainties becoming involved in the calculation of the combined standard uncertainty for the measurement.

**Receiving device: absolute level:** This uncertainty only contributes during the second stage of the procedure if the input attenuation range setting on the receiving device has been changed from its setting in the first stage. The standard uncertainty of the contribution due to the receiving device absolute level uncertainty is designated throughout all parts of ETR 273 [12] as  $u_{j47}$ .

NOTE 1: In this example case the uncertainty of the contribution due to the receiving device absolute level uncertainty (a range change is assumed) is obtained from the manufacturers data as  $\pm 0,5$  dB. As nothing is said about the distribution of this uncertainty, a rectangular distribution (see ETR 273 [12], part 1, subpart 1, clause 5.1.2) in logs is assumed. The standard uncertainty of the contribution due to the receiving device absolute level uncertainty is calculated as 0,29 dB.

**Receiving device: linearity:** In any test in which the contribution of the absolute level uncertainty of the receiving device contributes to the combined standard uncertainty of the test i.e. it does not cancel due to the methodology, the contribution from the receiving device linearity is considered to have been included in  $u_{j47}$ . Conversely, for any test in which the absolute level uncertainty of the receiving device does not contribute to the combined standard uncertainty the linearity of the receiving device should be included. The standard uncertainty of the contribution due to the receiving device linearity is designated throughout all parts of ETR 273 [12] as  $u_{j48}$ .

NOTE 2: In this example case the standard uncertainty of the contribution due to the receiving device linearity is taken as 0,00 dB.

### 6.9.2.2.3 Contribution from the random component

**Random uncertainty:** The magnitude can be assessed from multiple measurements of the radiated attenuation measurement. The standard uncertainty of the contribution due to the random uncertainty is designated throughout all parts of ETR 273 [12] as  $u_{i01}$ .

The radiated attenuation measurement was repeated 10 times. The following results were obtained in dB $\mu$ V (before correcting for cabling and attenuator network insertion loss):

- 65,4; 63,4; 66,0; 65,3; 63,0; 64,9; 65,2; 66,8; 65,5; 63,7.

Converting to linear terms:

- $1,862 \times 10^{-3}$ ;  $1,479 \times 10^{-3}$ ;  $1,995 \times 10^{-3}$ ;  $1,841 \times 10^{-3}$ ;  $1,413 \times 10^{-3}$ ;  $1,758 \times 10^{-3}$ ;  $1,820 \times 10^{-3}$ ;  $2,188 \times 10^{-3}$ ;  $1,884 \times 10^{-3}$ ;  $1,531 \times 10^{-3}$ ;

The two sums  $X$  and  $Y$  are calculated:

- $X =$  the sum of the measured values =  $17,77 \times 10^{-3}$ ;
- $Y =$  the sum of the squares of the measured values =  $32,10 \times 10^{-6} \text{ V}^2$ .

$$u_{c \text{ random}} = \sqrt{\frac{Y - \frac{X^2}{n}}{n-1}} = \sqrt{\frac{32,10 \times 10^{-6} - \frac{(17,77 \times 10^{-3})^2}{10}}{10-1}} = 238,3 \times 10^{-6} \text{ (formula 5.6)}$$

As the result is obtained as the mean value of 10 measurements and the standard uncertainty of the random uncertainty is:

$$u_{j \text{ random}} = \frac{238,3 \times 10^{-6}}{1,777 \times 10^{-3}} \times \frac{100}{11,5} = 1,17 \text{ dB}$$

NOTE: In this example case the standard uncertainty of the contribution due to the random uncertainty is 1,17 dB.

#### 6.9.2.2.4 Summary table of contributory components

A complete list of all the contributions to this part of the verification procedure is given in table 41.

**Table 41: Contributions from the radiated attenuation measurement**

<b>u<sub>j</sub> or i</b>	<b>Description of uncertainty contributions</b>	<b>dB</b>
U <sub>j36</sub>	mismatch: transmitting part	0,11
U <sub>j37</sub>	mismatch: receiving part	0,11
U <sub>j38</sub>	signal generator: absolute output level	0,00
U <sub>j39</sub>	signal generator: output level stability	0,01
U <sub>j41</sub>	insertion loss: signal generator cable	0,00
U <sub>j19</sub>	cable factor: signal generator cable	0,50
U <sub>j40</sub>	insertion loss: signal generator attenuator	0,00
U <sub>j34</sub>	ambient effect	0,00
U <sub>j33</sub>	Stripline: influence of site effects	3,00
U <sub>j31</sub>	Stripline: antenna factor of the monopole	1,15
U <sub>j40</sub>	insertion loss: receiving device attenuator	0,00
U <sub>j41</sub>	insertion loss: receiving device cable	0,00
U <sub>j19</sub>	cable factor: receiving device cable	0,50
U <sub>j47</sub>	receiving device: absolute level	0,29
U <sub>j48</sub>	receiving device: linearity	0,00
U <sub>i01</sub>	random uncertainty	1,17

The standard uncertainties from table 41 should be combined by RSS in accordance with ETR 273 [12], part 1, subpart 1, clause 5. This gives the combined standard uncertainty ( $u_{c \text{ Stripline attenuation measurement}}$ ) for the Stripline attenuation measurement in dB.

The value of  $u_{c \text{ Stripline attenuation measurement}}$  is calculated as 3,51 dB.

#### 6.9.2.2.5 Expanded uncertainty for the verification procedure

The combined standard uncertainty of the results of the verification procedure is the combination of the components outlined in clauses 6.9.2.1.4 and 6.9.2.2.4. The components to be combined are  $u_{c \text{ direct attenuation measurement}}$  and  $u_{c \text{ Stripline attenuation measurement}}$

$$u_{c \text{ Stripline verification procedure}} = \sqrt{0,223^2 + 3,51^2} = 3,51 \text{ dB}$$

The expanded uncertainty is  $\pm 1,96 \times 3,51 = \pm 6,89$  dB at a 95 % confidence level.

### 6.9.3 Example 2: The measurement of a receiver parameter (Sensitivity)

For the measurement of receiver sensitivity two stages of test are involved. The first stage (determining the Transform Factor of the Stripline) involves measuring the field strength at the point where the receiver will be placed and determining the relationship between the signal generator output power level and the resulting field strength. The second stage (the EUT measurement) involves placing the EUT within the Stripline and adjusting the output level of the signal generator until the required response is obtained on the receiver. The signal generator output power level is then converted to field strength using the Transform Factor.

### 6.9.3.1 Uncertainty contributions: Stage 1: EUT measurement

The first stage of the measurement is to determine the minimum signal generator output level which produces the required response from the EUT. The test equipment set-up is shown in see figure 37.

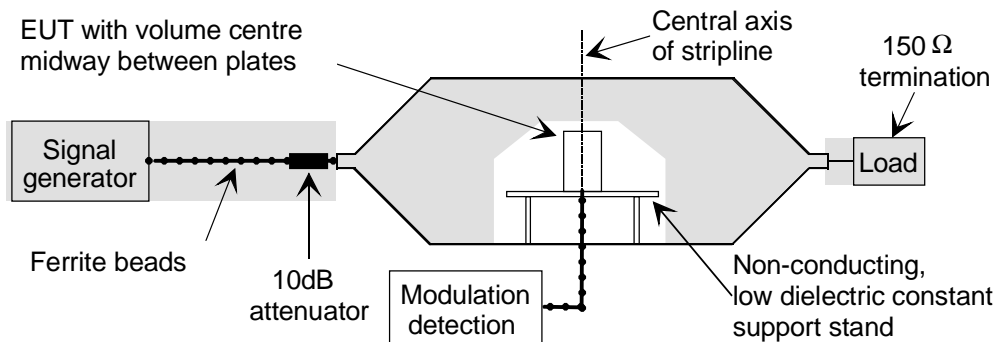

**Figure 37: Stage 1: EUT measurement**

Whereas figure 37 shows, schematically, the test equipment set-up for the EUT sensitivity measurement, figure 38, an analysis diagram, provides a detailed picture of the individual uncertainty components (each of which contributes its own uncertainty) for this stage in the measurement. As stated above, the shaded areas represent components common to both stages of the test method.

#### 6.9.3.1.1 Contributions from the mismatch components

**Mismatch: transmitting part:** The uncertainty due to mismatch for the measurement on the EUT concerns only the signal generator, the signal generator cable, the signal generator attenuator and the input to the Stripline. The mismatch uncertainty through this network does, however, contribute equally to both stages of the test for cases in which a field strength measurement is subsequently performed.

If, however, the results of the verification procedure are used to calculate the field strength, the contribution of the mismatch uncertainty needs to be calculated, from the approach described in annex G. All the contributions are U-distributed.

Signal generator:	Output reflection coefficient: $ \rho_G $	= 0,20
Cable:	Input and output reflection coefficients: $ S_{11} $ and $ S_{22} $	= 0,07
	Attenuation: 1 dB = $ S_{12}  =  S_{21} $	= 0,891
Attenuator:	Input and output reflection coefficients $ S_{11}  =  S_{22} $	= 0,05
	Attenuation = 10 dB $ S_{12}  =  S_{21} $	= 0,3162
Stripline:	Input reflection coefficient: $ \rho_{SL} $	= 0,333

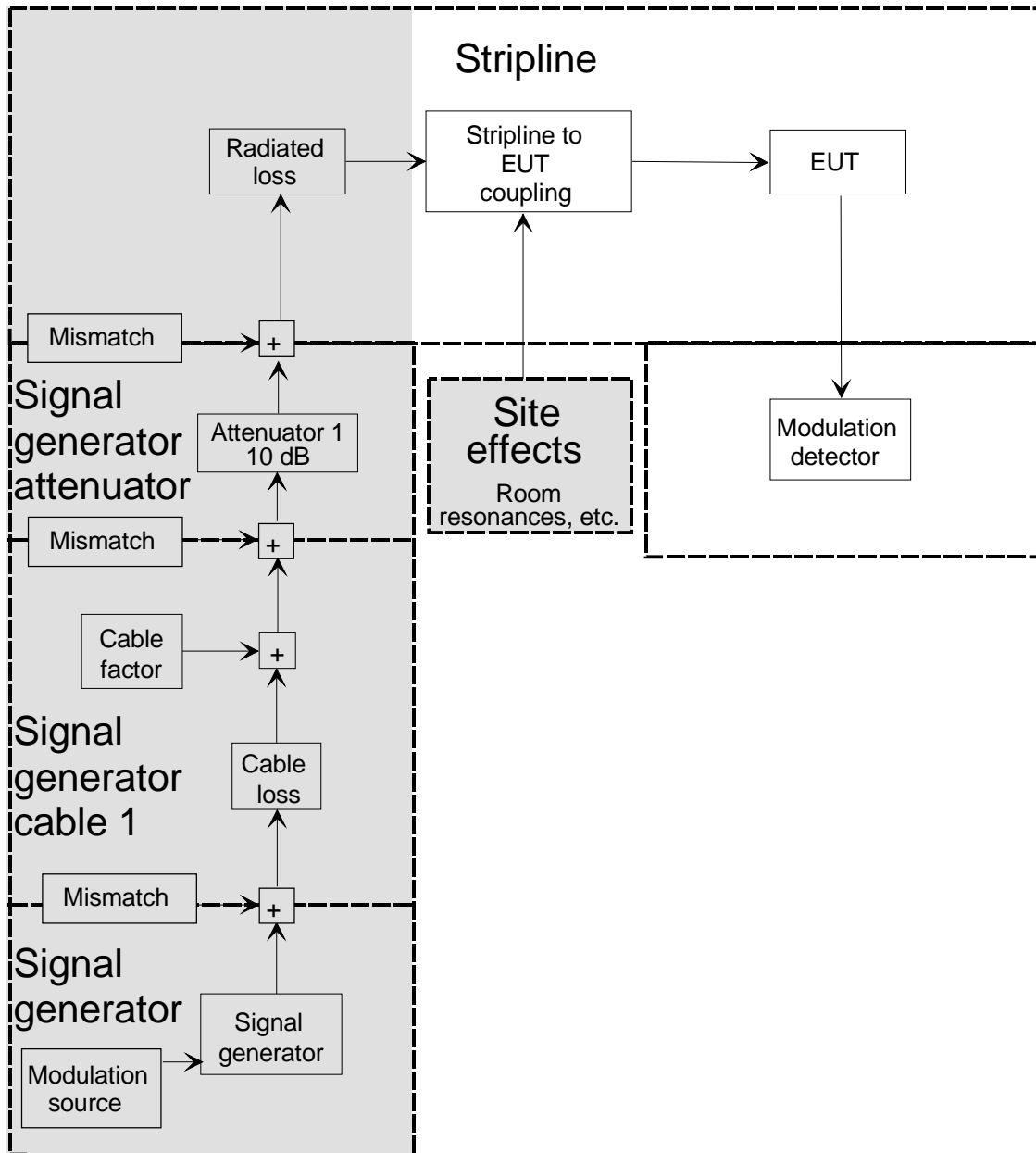

Figure 38: Schematic of the sensitivity measurement on the EUT

**Mismatch: transmitting part.**

All these contributions are U-distributed. Those components that cancel are not calculated. Other contributions are (see annex G):

- $u_{j \text{ mismatch: generator and cable } i}$ : Constant for both stage 1 and 2. Hence this value does not contribute.
- $u_{j \text{ mismatch: cable 1 and attenuator } i}$ : Constant for both stage 1 and 2. Hence this value does not contribute.

$$u_{j \text{ mismatch: attenuator and Stripline}} = \frac{0,05 \times 0,333 \times 100}{\sqrt{2}} \% = 1,177\%$$

- $u_{j \text{ generator and attenuator } i}$ : Constant for both stage 1 and 2. Hence this value does not contribute.

$$u_{j \text{ mismatch: cable 1 and Stripline}} = \frac{0,07 \times 0,333 \times 0,316^2 \times 100}{\sqrt{2}} \% = 0,165\%$$

$$u_{jmismatch:generatorandStripline} = \frac{0,2 \times 0,333 \times 0,891^2 \times 0,316^2 \times 100}{\sqrt{2}} \% = 0,373\%$$

The combined standard uncertainty of the mismatch is then calculated:

$$u_{cmismatch:transmitting\ part} = \sqrt{1,177^2 + 0,165^2 + 0,373^2} = 1,25\%$$

Transforming to the logarithmic form (ETR 028 [15], part 2, annex E):  $1,25\% / 11,5 = 0,11\text{ dB}$ .

The standard uncertainty of the contribution due to the mismatch in the transmitting part, is designated throughout all parts of ETR 273 [12] as  $u_{j36}$ . Its value in this example is 0,11 dB.

### 6.9.3.1.2 Contributions from the individual components

#### 6.9.3.1.2.1 Signal generator

**Signal generator: absolute output level:** In this test method, the uncertainty due to the setting of the signal generator's absolute output level contributes to both stages. In stage 1, the output level is individually adjusted at each of 8 different positioning angles whilst in stage 2, after an inspection (or calculation) of the 8 different values, the signal generator is set to a specific output level. The standard uncertainty of the contribution due to the signal generator absolute output level uncertainty is designated throughout all parts of ETR 273 [12] as  $u_{j38}$ . Its value can be obtained from the manufacturer's data sheet.

NOTE 1: In this example case the uncertainty of the contribution due to the signal generator absolute output level is obtained from the manufacturers data sheet as  $\pm 1,0\text{ dB}$ . As nothing is said about the distribution of this uncertainty, a rectangular distribution (see ETR 273 [12], part 1, subpart 1, clause 5.1.2) in logs is assumed, and the standard uncertainty is calculated as 0,58 dB.

**Signal generator: output level stability:** In any test in which the contribution of the absolute level uncertainty of the signal generator contributes to the combined standard uncertainty of the test i.e. it does not cancel due to the methodology, the contribution from the output level stability is considered to have been included in the signal generator absolute output level,  $u_{j38}$ . Conversely, for any level in which the absolute level uncertainty of the signal generator does not contribute to the combined standard uncertainty, the output level stability of the signal generator should be included. The standard uncertainty of the contribution due to the signal generator output level stability is designated throughout all parts of ETR 273 [12] as  $u_{j39}$ . Its value can be derived from manufacturers' data sheet.

NOTE 2: In this example case the standard uncertainty of the contribution due to the signal generator output level stability is taken as 0,0 dB as it is covered by the absolute level uncertainty.

#### 6.9.3.1.2.2 Signal generator cable

**Insertion loss: signal generator cable:** The signal generator cable has an insertion loss as well as an uncertainty associated with the measurement of its magnitude. The value of insertion loss and its uncertainty remain valid provided the cable is not used outside the manufacturer's specification. At any given frequency the insertion loss acts as a systematic offset and contributes equally to both stages of the measurement. The standard uncertainty of the contribution due to the insertion loss uncertainty of the signal generator cable is designated throughout all parts of ETR 273 [12] as  $u_{j41}$ .

NOTE 1: In this example case the standard uncertainty of the contribution due to the insertion loss uncertainty of the signal generator cable is taken as 0,20 dB as the results of the verification procedure have been used to determine the field strength and this value has been taken from the manufacturer's or calibration data.

NOTE 2: If a field measurement had been performed using either a monopole or 3-axis probe the value **would have been** 0,00 dB as the uncertainty is systematic i.e. it produces the same offset in both stages.

**Cable factor: signal generator cable:** Cable factor is defined as the total effect of the signal generator cable's influence on the measuring system including its interaction with the site. It consists of the leakage caused by cable screening inefficiency and introducing an unbalanced current into the Stripline. In a radiated measurement the standard uncertainty of the cable factor, associated with each cable, is 0,5 dB provided that the precautions detailed in the methods have been observed. i.e. routing and dressing of cables with ferrites. If no prevention has been attempted the standard uncertainty is 4,0 dB (justification for these values is given in ETR 273 [12], part 1, subpart 2, annex E). The standard uncertainty of the contribution due to the cable factor of the signal generator cable is designated throughout all parts of ETR 273 [12] as  $u_{j19}$ .

NOTE 3: In this example case the standard uncertainty of the contribution due to the cable factor of the signal generator cable is taken as 0,5 dB since the precautions detailed in the test method have been observed.

#### 6.9.3.1.2.3 Signal generator attenuator

**Insertion loss: signal generator attenuator:** The signal generator attenuator has an insertion loss as well as an uncertainty associated with the measurement of its magnitude. The value of insertion loss and its uncertainty remain valid provided the attenuator is not used outside the manufacturer's specification. At any given frequency the insertion loss acts as a systematic offset and contributes equally to both stages of the measurement. The standard uncertainty of the contribution due to the insertion loss of the signal generator attenuator is designated throughout all parts of ETR 273 [12] as  $u_{j40}$ .

NOTE 1: In this example case the standard uncertainty of the contribution due to the insertion loss uncertainty of the signal generator cable is taken as 0,20 dB as the results of the verification procedure have been used to determine the field strength and this value has been taken from the manufacturer's or calibration data.

NOTE 2: If a field measurement had been performed using either a monopole or 3-axis probe the value **would have been** 0,00 dB as the uncertainty is systematic i.e. it produces the same offset in both stages.

#### 6.9.3.1.2.4 Site factors

**Ambient effect:** Uncertainty is introduced as a result of local ambient signals raising the noise floor at the measurement frequency. The standard uncertainty of the contribution due to the ambient effect is designated throughout all parts of ETR 273 [12] as  $u_{j34}$ . The value of the standard uncertainty is the same as for the second stage.

NOTE 1: In this example case the standard uncertainty of the contribution due to the ambient effect is taken as 0,00 dB since the Stripline is assumed to have been placed in a shielded room.

**Stripline: influence of site effects:** The influence of site effects comprise those effects, resulting from not observing the recommendations given in EN 55020 [16] regarding positioning of the Stripline and layout of absorber. These can lead to incorrect received levels i.e. values which differ from theoretical calculations. In this example, the recommendations are assumed not to have been fully observed. The standard uncertainty of the contribution due to the influence of site effects is designated throughout all parts of ETR 273 [12] as  $u_{j33}$ .

NOTE 2: In this example case the standard uncertainty of the contribution due to the influence of site effects is taken as 3,0 dB since in the verification procedure, site effects only contribute to the Stripline attenuation part and therefore do not cancel.

NOTE 3: If a field measurement had been performed using either a monopole or 3-axis probe the value **would have been** 0,00 dB as the uncertainty is systematic i.e. it produces the same offset in both stages.

## 6.9.3.1.2.5 EUT

**Stripline: mutual coupling of the EUT to its images in the plates:** The magnitude is dependent on the EUT's size. The EUT is assumed to be positioned midway between the plates. The standard uncertainty of the contribution due to the mutual coupling of the EUT to its images in the plates is designated throughout all parts of ETR 273 [12] as  $u_{j24}$ . Its value can be obtained from table 42.

**Table 42: Uncertainty contribution of the mutual coupling of the EUT to its images in the plates**

Size of the EUT relative to the plate separation	Standard uncertainty of the contribution
size/separation < 33 %	1,15 dB
33 % ≤ size/separation < 50 %	1,73 dB
50 % ≤ size/separation < 70 %	2,89 dB
70 % ≤ size/separation ≤ 87,5 % (max.)	5,77 dB

NOTE 1: In this example case the standard uncertainty of the contribution due to the mutual coupling of the EUT to its images in the plates is 1,15 dB since it is assumed the equipment size is < 33 % of the plate separation.

**Stripline: characteristic impedance:** This uncertainty contribution results from the difference between the free-space wave impedance (377 Ω) for which the EUT had been developed and that for the Stripline (150 Ω). The standard uncertainty of the contribution due to the characteristic impedance of the Stripline is designated throughout all parts of ETR 273 [12] as  $u_{j26}$ .

NOTE 2: In this example case the standard uncertainty of the contribution due to the characteristic impedance of the Stripline is taken as having a standard uncertainty of 0,58 dB.

**Stripline: correction factor for the size of the EUT:** This uncertainty is the result of changes in the intensity of the electric field between the plates resulting from the presence, and metal content of the EUT. The larger the size of the EUT in the vertical plane of the Stripline, the greater the field intensification effect. Correction factors are supplied within the test method, and the associated standard uncertainty of the contribution of the uncertainty due to the correction factor for the size of the EUT is designated throughout all parts of ETR 273 [12] as  $u_{j32}$ . For EUT mounted centrally in the Stripline, values can be obtained from table 43.

**Table 43: Uncertainty contribution: Stripline: correction factor for the size of the EUT**

Height of the EUT (in the E-plane) is:	Standard uncertainty of the contribution
height < 0,2 m	0,30 dB
0,2 m ≤ height < 0,4 m	0,60 dB
0,4 m ≤ height ≤ 0,7 m	1,20 dB

NOTE 3: In this example case the standard uncertainty of the contribution of the uncertainty due to the correction factor for the size of the EUT is taken as 0,60 dB as the EUT is 0,22 m high.

**EUT: mutual coupling to the power leads:** This is the uncertainty associated with the influence (reflections, parasitic effects, etc.) of the power leads on the EUT. The standard uncertainty associated with this effect is 0,5 dB provided that the precautions detailed in the methods have been observed. i.e. routing and dressing of cables with ferrites. If no prevention has been attempted the standard uncertainty is 2,0 dB. The standard uncertainty of the contribution due to the mutual coupling of the EUT to the power leads is designated throughout all parts of ETR 273 [12] as  $u_{j54}$ .

NOTE 4: In this example case the standard uncertainty of the contribution due to the mutual coupling of the EUT to the power leads is taken as 0,5 dB since the precautions detailed in the methods have been observed.

**Stripline: non-planar nature of the field distribution:** This uncertainty results from the non-uniform amplitude and phase distribution of the electric field across the EUT. The non-uniformity results from room resonances, constructional problems, moding, reflections, etc. The standard uncertainty of the contribution due to the non-planar nature of the field distribution is designated throughout all parts of ETR 273 [12] as  $u_{j27}$ .

NOTE 5: In this example case the standard uncertainty of the contribution due to the non-planar nature of the field distribution is taken as 0,29 dB.



**EUT: degradation measurement:** This contribution is a RF level uncertainty associated with the uncertainty of measuring 20 dB SINAD,  $10^{-2}$  bit stream or 80 % message acceptance ratio. The standard uncertainty of the contribution due to the EUT degradation measurement, designated throughout all parts of ETR 273 [12] as  $u_{j52}$ , can be obtained from ETR 028 [15].

NOTE 6: In this example case, the standard uncertainty of the contribution is obtained from ETR 028 [15] and its value is 0,68 dB.

### 6.9.3.1.3 Contribution from the random component

**Random uncertainty:** The magnitude can be assessed from multiple measurements of the receiver sensitivity measurement. The standard uncertainty of the contribution due to the random uncertainty is designated throughout all parts of ETR 273 [12] as  $u_{i01}$ .

The receiver sensitivity measurement was repeated 10 times. The following results were obtained in dB $\mu$ V (before correcting for cabling and attenuator network insertion loss):

- 65,4; 63,4; 66,0; 65,3; 63,0; 64,9; 65,2; 66,8; 65,5; 63,7.

Converting to linear terms:

- $1,862 \times 10^{-3}$ ;  $1,479 \times 10^{-3}$ ;  $1,995 \times 10^{-3}$ ;  $1,841 \times 10^{-3}$ ;  $1,413 \times 10^{-3}$ ;  $1,758 \times 10^{-3}$ ;  $1,820 \times 10^{-3}$ ;  $2,188 \times 10^{-3}$ ;  $1,884 \times 10^{-3}$ ;  $1,531 \times 10^{-3}$ .

The two sums  $X$  and  $Y$  are calculated:

- $X$  = the sum of the measured values =  $17,77 \times 10^{-3}$ ;
- $Y$  = the sum of the squares of the measured values =  $32,10 \times 10^{-6} \text{ V}^2$ .

$$u_{c \text{ random}} = \sqrt{\frac{Y - \frac{X^2}{n}}{n-1}} = \sqrt{\frac{32,10 \times 10^{-6} - \frac{(17,77 \times 10^{-3})^2}{10}}{10-1}} = 238,3 \times 10^{-6} \text{ (formula 5.6)}$$

As the result is obtained as the mean value of 10 measurements and the standard uncertainty of the random uncertainty is:

$$u_{j \text{ random}} = \frac{238,3 \times 10^{-6}}{1,777 \times 10^{-3}} \times \frac{100}{11,5} = 1,17 \text{ dB}$$

NOTE: In this example case the standard uncertainty of the contribution due to the random uncertainty is 1,17 dB.

### 6.9.3.1.4 Summary table of contributory components

A complete list of all the contributions to this part of the test method is given in table 44.

**Table 44: Contributions from the measurement on the EUT**

$u_j$ or $i$	Description of uncertainty contributions	dB
$u_{j36}$	mismatch: transmitting part: a) Using results of the verification procedure; b) Using a monopole for field measurement; c) Using a 3-axis probe for field measurement.	0,11 0,00 0,00
$u_{j38}$	signal generator: absolute output level	0,58
$u_{j39}$	signal generator: output level stability	0,00
$u_{j41}$	insertion loss: signal generator cable: a) Using results of the verification procedure; b) Using a monopole for field measurement; c) Using 3-axis probe for field measurement.	0,20 0,00 0,00
$u_{j19}$	cable factor: signal generator cable	0,50
$u_{j40}$	insertion loss: signal generator attenuator: a) Using results of the verification procedure; b) Using a monopole for field measurement; c) Using a 3-axis probe for field measurement.	0,20 0,00 0,00
$u_{j34}$	ambient effect	0,00
$u_{j33}$	Stripline: influence of site effects: a) Using results of the verification procedure; b) Using a monopole for field measurement; c) Using a 3-axis probe for field measurement.	3,00 0,00 0,00
$u_{j24}$	Stripline: mutual coupling of the EUT to its images in the plates	1,15
$u_{j26}$	Stripline: characteristic impedance	0,58
$u_{j32}$	Stripline: correction factor for the size of the EUT	0,60
$u_{j55}$	EUT: mutual coupling to the power leads	0,50
$u_{j27}$	Stripline: non-planar nature of the field distribution	0,29
$u_{j52}$	EUT: degradation measurement	0,68
$u_{i01}$	random uncertainty	1,17

The standard uncertainties from table 44 should be combined by RSS in accordance with ETR 273 [12], part 1, subpart 1, clause 5. This gives the combined standard uncertainty for the direct attenuation measurement in dB as follows:

- using results of the verification procedure =  $u_{c \text{ measurement of the EUT}} = 3,72$  dB;
- using a monopole for field measurement =  $u_{c \text{ measurement of the EUT}} = 2,18$  dB;
- using a 3-axis probe for field measurement =  $u_{c \text{ measurement of the EUT}} = 2,18$  dB.

### 6.9.3.2 Uncertainty contributions: Stage 2: Field measurement using the results of the verification procedure

**Stripline: interpolation of values for the Transform Factor:** In this case, the frequency of test does not coincide with a frequency at which the verification procedure was carried out. Therefore, a contribution is included to account for the interpolation between Transform Factor values. The standard uncertainty of the contribution due to the interpolation of values for the Transform Factor of the Stripline is designated throughout all parts of ETR 273 [12] as  $u_{j30}$ .

NOTE: In this example case the standard uncertainty of the contribution due to the interpolation of values for the Transform Factor is taken as 0,29 dB.

The appropriate standard uncertainties from table 44 should be combined with  $u_{j30}$  by RSS in accordance with ETR 273 [12], part 1, subpart 1, clause 5. This gives the combined standard uncertainty ( $u_{c \text{ EUT measurement}}$ ) for the EUT measurement in dB.

The value of  $u_{c \text{ EUT measurement}}$  is calculated as 3,56 dB.

### 6.9.3.2.1 Expanded uncertainty for the receiver sensitivity measurement

The combined standard uncertainty of the results of the receiver sensitivity measurement is the combination of  $u_{c \text{ Stripline attenuation measurement}}$  and  $u_{c \text{ EUT measurement}}$

$$u_{c \text{ receiversensitivitymeasurement}} = \sqrt{3,51^2 + 3,72^2} = 5,11 \text{ dB}$$

The expanded uncertainty is  $\pm 1,96 \times 5,11 = \pm 10,0$  dB at a 95 % confidence level.

### 6.9.3.3 Uncertainty contributions: Stage 2: Field measurement using a monopole

The second stage involves replacing the EUT with a field measuring device (either a monopole antenna or a 3-axis probe) and, setting a particular output level from the signal generator (minimum or average), measuring the corresponding field strength, see figure 39.

NOTE: In this case monopole field measurement involves mounting the monopole through a hole in the lower plate of the Stripline (so that the feed point to the monopole is flush with the surface of the lower plate) and measuring the field strength.

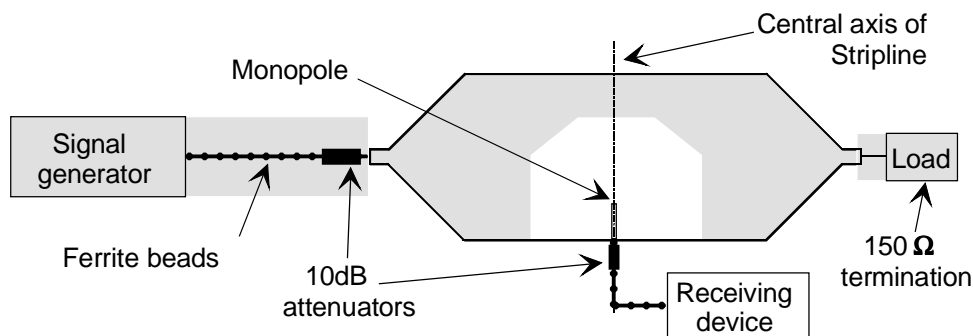

Figure 39: Stage 2: Field measurement using a monopole

#### 6.9.3.3.1 Contributions from the mismatch components

**Mismatch in the transmitting and receiving parts:** Whereas figure 39 shows schematically the equipment set-up for field measurement using a monopole, figure 40 provides a detailed picture of the individual uncertainty contributions.

**Mismatch: transmitting part:** The mismatch uncertainty between the signal generator, signal generator cable, signal generator attenuator and the Stripline input can be calculated from the approach described in annex G. The mismatch uncertainty through this network does, however, contribute equally to both stages of the test for cases in which a field strength measurement is subsequently performed since there are no changes from stage 1 to this part of the test set-up. The standard uncertainty of the contribution due to the mismatch in the transmitting part is designated throughout all parts of ETR 273 [12] as  $u_{j36}$ .

NOTE 1: In this example case the standard uncertainty of the contribution due to mismatch in the transmitting part is taken as 0,00 dB, since the uncertainty is systematic i.e. it produces the same offset in both stages.

#### **Mismatch: receiving part:**

The mismatch uncertainty in the receiving part i.e. between the monopole, receiving device attenuator, receiving device cable and the receiving device is calculated from the approach described in annex G. This mismatch uncertainty contributes only during the field measurement part of the test and therefore contributes to the combined standard uncertainty.

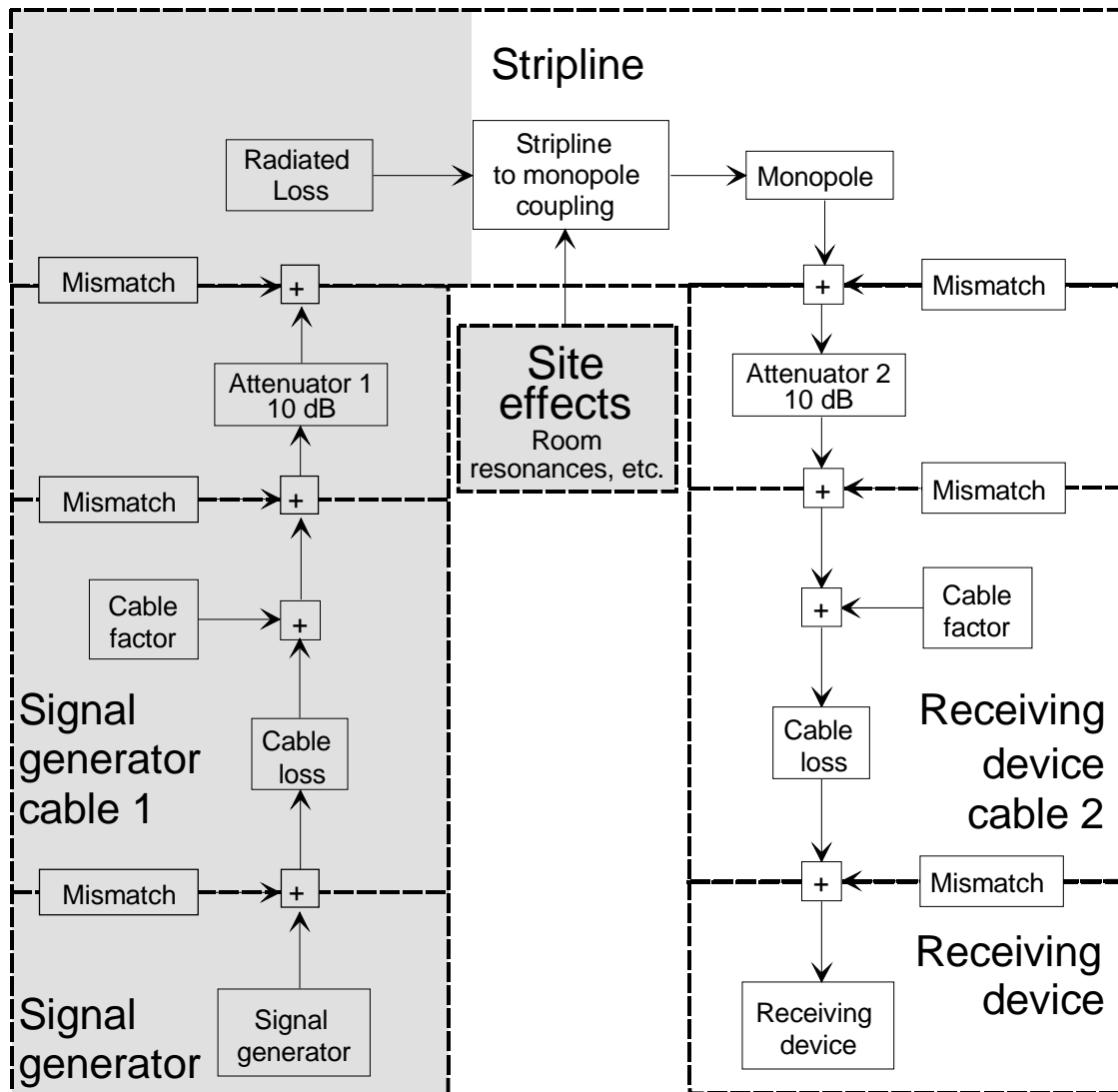

Figure 40: Schematic of the field measurement using a monopole

Monopole:	Input reflection coefficient: $ \rho_M $	= 0,333
Attenuator:	Input and output reflection coefficients $ S_{11}  =  S_{22} $	= 0,05
	Attenuation = 10 dB $ S_{12}  =  S_{21} $	= 0,3162
Cable:	Input and output reflection coefficients: $ S_{11} $ and $ S_{22} $	= 0,07
	Attenuation: 1 dB = $ S_{12}  =  S_{21} $	= 0,891
Receiving device:	Output reflection coefficient: $ \rho_{RD} $	= 0,20

All these contributions are U-distributed. Other contributions are (see annex G):

$$u_{j\text{mismatch:antennaandattenuator}} = \frac{0,333 \times 0,05 \times 100}{\sqrt{2}} \% = 1,177\%$$

- $u_{j\text{attenuator 2 and cable 2}}$ : Constant for both stage 1 and 2. Hence this value does not contribute.
- $u_{j\text{cable 2 and receiving device}}$ : Constant for both stage 1 and 2. Hence this value does not contribute.

$$u_{jmismatch:antennaandcable2} = \frac{0,333 \times 0,07 \times 0,316^2 \times 100}{\sqrt{2}} \% = 0,165\%$$

- $u_{jattenuator\ 2\ and\ receiving\ device}$ : Constant for both stage 1 and 2. Hence this value does not contribute.

$$u_{jmismatch:antennaandreceivingdevice} = \frac{0,333 \times 0,2 \times 0,316^2 \times 0,891^2 \times 100}{\sqrt{2}} \% = 0,373\%$$

The combined standard uncertainty of the mismatch is then calculated:

$$u_{jmismatch:receiving\ part} = \sqrt{1,177^2 + 0,165^2 + 0,373^2} = 1,25\%$$

Transforming to the logarithmic form (ETR 028 [15], part 2, annex E):  $1,25\% / 11,5 = 0,11\text{ dB}$ .

The standard uncertainty of the contribution, due to the mismatch in the receiving part, is designated throughout all parts of ETR 273 [12] as  $u_{j37}$ . Its value in this example is 0,11 dB.

### 6.9.3.3.2 Contributions from the individual components

#### 6.9.3.3.2.1 Signal generator

**Signal generator: absolute output level:** In this test method, the uncertainty due to the setting of the signal generator's absolute output level contributes to both stages. In stage 1, the output level is individually adjusted at each of 8 different positioning angles whilst in stage 2, after an inspection (or calculation) of the 8 different values, the signal generator is set to a specific output level. The standard uncertainty of the contribution due to the signal generator absolute output level is designated throughout all parts of ETR 273 [12] as  $u_{j38}$ . Its value can be obtained from the manufacturer's data sheet.

NOTE 1: In this example case the uncertainty of the contribution due to the signal generator absolute output level uncertainty from the manufacturer's data sheet is  $\pm 1,0\text{ dB}$ . As nothing is said about the distribution of this uncertainty, a rectangular distribution (see ETR 273 [12], part 1, subpart 1, clause 5.1.2) in logs is assumed, and the standard uncertainty is calculated as 0,58 dB.

**Signal generator: output level stability:** In any test in which the contribution of the absolute level uncertainty of the signal generator contributes to the combined standard uncertainty of the test i.e. it does not cancel due to the methodology, the contribution from the output level stability is considered to have been included in the signal generator absolute output level,  $u_{j38}$ . Conversely, for any level in which the absolute level uncertainty of the signal generator does not contribute to the combined standard uncertainty, the output level stability of the signal generator should be included. The standard uncertainty of the contribution due to the signal generator output level stability is designated throughout all parts of ETR 273 [12] as  $u_{j39}$ . Its value can be derived from manufacturers' data sheet.

NOTE 2: In this example case the standard uncertainty of the contribution due to the signal generator output level stability is taken as 0,00 dB as it is covered by the absolute level uncertainty.

#### 6.9.3.3.2.2 Signal generator cable

**Insertion loss: signal generator cable:** The signal generator cable has an insertion loss as well as an uncertainty associated with the measurement of its magnitude. The value of insertion loss and its uncertainty remain valid provided the cable is not used outside the manufacturer's specification. At any given frequency the insertion loss acts as a systematic offset and contributes equally to both stages of the measurement. The standard uncertainty of the contribution due to the insertion loss uncertainty of the signal generator cable is designated throughout all parts of ETR 273 [12] as  $u_{j41}$ .

NOTE 1: In this example case the standard uncertainty of the contribution due to the insertion loss uncertainty of the signal generator cable is taken as 0,00 dB since the uncertainty is systematic i.e. it is assumed constant and common to both stages of the measurement.

**Cable factor: signal generator cable:** Cable factor is defined as the total effect of the signal generator cable's influence on the measuring system including its interaction with the site. It consists of the leakage caused by cable screening inefficiency and introducing an unbalanced current into the Stripline. In a radiated measurement the standard uncertainty of the uncertainty due to cable factor, associated with each cable, is 0,5 dB provided that the precautions detailed in the methods have been observed. i.e. routing and dressing of cables with ferrites. If no prevention has been attempted the standard uncertainty is 4,0 dB (justification for these values is given in ETR 273 [12], part 1, subpart 2, annex E). The standard uncertainty of the contribution due to the cable factor of the signal generator cable is designated throughout all parts of ETR 273 [12] as  $u_{j19}$ .

NOTE 2: In this example case the standard uncertainty of the contribution due to the cable factor of the signal generator cable is taken as 0,00 dB since the precautions detailed in the methods have been observed and the field strength is to be measured.

#### 6.9.3.3.2.3 Signal generator attenuator

**Insertion loss: signal generator attenuator:** The signal generator attenuator has an insertion loss as well as an uncertainty associated with the measurement of its magnitude. The value of insertion loss and its uncertainty remain valid provided the attenuator is not used outside the manufacturer's specification. At any given frequency the insertion loss acts as a systematic offset and contributes equally to both stages of the measurement. The standard uncertainty of the contribution due to the insertion loss uncertainty of the signal generator attenuator is designated throughout all parts of ETR 273 [12] as  $u_{j40}$ .

NOTE: In this example case the standard uncertainty of the contribution due to the insertion loss uncertainty of the signal generator attenuator is 0,00 dB since the precautions detailed in the methods have been observed and the field strength is to be measured.

#### 6.9.3.3.2.4 Site factors

**Ambient effect:** Ambient effect is the uncertainty caused by local ambient signals raising the noise floor at the measurement frequency. The standard uncertainty of the contribution due to the ambient effect is designated throughout all parts of ETR 273 [12] as  $u_{j34}$ . The value of the standard uncertainty should be taken from table 45.

**Table 45: Uncertainty contribution: Ambient effect**

Receiving device noise floor (EUT OFF) is within:	Standard uncertainty of the contribution
3 dB of measurement	1,57 dB
3 dB to 6 dB of measurement	0,80 dB
6 dB to 10 dB of measurement	0,30 dB
10 dB to 20 dB of measurement	0,10 dB
20 dB or more of the measurement	0,00 dB

NOTE 1: In this example case the standard uncertainty of the contribution due to the ambient effect is taken as 0,00 dB since the Stripline is assumed to have been placed in a shielded room.

**Stripline: influence of site effects:** The influence of site effects comprise those effects, resulting from not observing the recommendations given in EN 55020 [16] regarding positioning of the Stripline and layout of the absorber. These can lead to incorrect received levels i.e. values which differ from theoretical calculations. The standard uncertainty of the contribution due to the influence of site effects is designated throughout all parts of ETR 273 [12] as  $u_{j33}$ .

NOTE 2: In this example case the standard uncertainty of the contribution due to the influence of site effects is taken to be 0,00 dB since in this test method, site effects contribute equally to both stages as the recommendations are assumed to have been fully observed.

#### 6.9.3.3.2.5 Antenna factor of the monopole

**Stripline: antenna factor of the monopole:** This has been derived from measurements taken within the Stripline. Therefore, the given values incorporate several of the field disturbance factors which the Stripline possesses and which therefore do not have to be allowed for as individual contributions. Amongst these included effects are imaging, characteristic impedance of the line, non-planar nature of the field etc. The standard uncertainty of the contribution due to the antenna factor of the monopole is designated throughout all parts of ETR 273 [12] as  $u_{j30}$ .

NOTE: In this example case the standard uncertainty of the contribution due to the antenna factor of the monopole is taken as 1,15 dB. This combined uncertainty source is only present in the actual measurement.

#### 6.9.3.3.2.6 Monopole attenuator

**Insertion loss: Monopole attenuator:** The monopole attenuator has an insertion loss as well as an uncertainty associated with the measurement of its magnitude. The value of insertion loss and its uncertainty remain valid provided the attenuator is not used outside the manufacturer's specification. The standard uncertainty of the contribution due to the insertion loss uncertainty of the monopole attenuator is designated throughout all parts of ETR 273 [12] as  $u_{j40}$ .

NOTE: In this example case the standard uncertainty of the contribution due to the insertion loss uncertainty of the monopole attenuator is taken as 0,1 dB since the uncertainty contributes only to stage 2 of this test method.

#### 6.9.3.3.2.7 Receiving device cable

**Insertion loss: receiving device cable:** The receiving device cable has an insertion loss as well as an uncertainty associated with the measurement of its magnitude. The value of insertion loss and its uncertainty remain valid provided the cable is not used outside the manufacturer's specification. At any given frequency the insertion loss acts as a systematic offset and contributes equally to both stages of the measurement. The standard uncertainty of the contribution due to the insertion loss uncertainty of the receiving device cable is designated throughout all parts of ETR 273 [12] as  $u_{j41}$ .

NOTE 1: In this example case the standard uncertainty of the contribution due to the insertion loss uncertainty of the receiving device cable is taken as 0,15 dB since the uncertainty is only present in the second stage of this test method.

**Cable factor: receiving device cable:** Cable factor is defined as the total effect of the receiving device cable's influence on the measuring system including its interaction with the site. It consists of the leakage caused by cable screening inefficiency and introducing an unbalanced current into the monopole. In a radiated measurement the standard uncertainty of the cable factor, associated with each cable, is 0,5 dB provided that the precautions detailed in the methods have been observed. i.e. routing and dressing of cables with ferrites. If no prevention has been attempted the standard uncertainty is 4,0 dB (justification for these values is given in ETR 273 [12], part 1, subpart 2, annex E). The standard uncertainty of the contribution due to the cable factor of the receiving device cable is designated throughout all parts of ETR 273 [12] as  $u_{j19}$ .

NOTE 2: In this example case the standard uncertainty of the contribution due to the cable factor of the receiving antenna cable is taken as 0,50 dB since the precautions detailed in the methods are assumed to have been observed.

#### 6.9.3.3.2.8 Receiving device

**Receiving device: absolute level:** This uncertainty only contributes during the second stage of the procedure if the input attenuation range setting on the receiving device has been changed from its setting in the first stage. The standard uncertainty of the contribution due to the receiving device absolute level uncertainty is designated throughout all parts of ETR 273 [12] as  $u_{j47}$ .

NOTE 1: In this example case the standard uncertainty of the contribution due to the receiving device absolute level uncertainty (a range change is assumed) is obtained from the manufacturers data as  $\pm 0,5$  dB. As nothing is said about the distribution of this uncertainty, a rectangular distribution (see ETR 273 [12], part 1, subpart 1, clause 5.1.2) in logs is assumed, and the standard uncertainty is calculated as 0,29 dB.

**Receiving device: linearity:** In any test in which the contribution of the absolute level uncertainty of the receiving device contributes to the combined standard uncertainty of the test i.e. it does not cancel due to the methodology, the contribution from the receiving device linearity is considered to have been included in  $u_{j47}$ . Conversely, for any test in which the absolute level uncertainty of the receiving device does not contribute to the combined standard uncertainty the linearity of the receiving device should be included. The standard uncertainty of the contribution due to the receiving device linearity is designated throughout all parts of ETR 273 [12] as  $u_{j48}$ .

NOTE 2: In this example case the standard uncertainty of the contribution due to the receiving device linearity is taken as 0,00 dB.

### 6.9.3.3.3 Contribution from the random component

**Random uncertainty:** The magnitude can be assessed from multiple measurements of the field strength measurement. The standard uncertainty of the contribution due to the random uncertainty is designated throughout all parts of ETR 273 [12] as  $u_{j01}$ .

The field strength measurement was repeated 10 times. The following results were obtained in dB $\mu$ V (before correcting for cabling and attenuator network insertion loss):

- 65,4; 63,4; 66,0; 65,3; 63,0; 64,9; 65,2; 66,8; 65,5; 63,7.

Converting to linear terms:

- $1,862 \times 10^{-3}$ ;  $1,479 \times 10^{-3}$ ;  $1,995 \times 10^{-3}$ ;  $1,841 \times 10^{-3}$ ;  $1,413 \times 10^{-3}$ ;  $1,758 \times 10^{-3}$ ;  $1,820 \times 10^{-3}$ ;  $2,188 \times 10^{-3}$ ;  $1,884 \times 10^{-3}$ ;  $1,531 \times 10^{-3}$ ;

The two sums  $X$  and  $Y$  are calculated:

- $X$  = the sum of the measured values =  $17,77 \times 10^{-3}$ ;
- $Y$  = the sum of the squares of the measured values =  $32,10 \times 10^{-6} \text{ V}^2$ .

$$u_{c \text{ random}} = \sqrt{\frac{Y - \frac{X^2}{n}}{n-1}} = \sqrt{\frac{32,10 \times 10^{-6} - \frac{(17,77 \times 10^{-3})^2}{10}}{10-1}} = 238,3 \times 10^{-6} \text{ (formula 5.6)}$$

As the result is obtained as the mean value of 10 measurements and the standard uncertainty of the random uncertainty is:

$$u_{j \text{ random}} = \frac{238,3 \times 10^{-6}}{1,777 \times 10^{-3}} \times \frac{100}{11,5} = 1,17 \text{ dB}$$

NOTE: In this example case the standard uncertainty of the contribution due to the random uncertainty is 1,17 dB.



#### 6.9.3.3.4 Summary table of contributions

A complete list of all the contributions to this part of the test method is given in table 46.

**Table 46: Contributions from the monopole field measurement**

<b>u<sub>j</sub> or i</b>	<b>Description of uncertainty contributions</b>	<b>dB</b>
U <sub>j36</sub>	mismatch: transmitting part	0,00
U <sub>j37</sub>	mismatch: receiving part	0,11
U <sub>j38</sub>	signal generator: absolute output level	0,58
U <sub>j39</sub>	signal generator: output level stability	0,00
U <sub>j41</sub>	insertion loss: signal generator cable	0,00
U <sub>j19</sub>	cable factor: signal generator cable	0,50
U <sub>j40</sub>	insertion loss: signal generator attenuator	0,00
U <sub>j34</sub>	ambient effect	0,00
U <sub>j33</sub>	Stripline: influence of site effects	0,00
U <sub>j31</sub>	Stripline: antenna factor of the monopole	1,15
U <sub>j40</sub>	insertion loss: monopole attenuator	0,10
U <sub>j41</sub>	insertion loss: receiving device cable	0,15
U <sub>j19</sub>	cable factor: receiving device cable	0,50
U <sub>j47</sub>	receiving device: absolute level	0,29
U <sub>j48</sub>	receiving device: linearity	0,00
U <sub>i01</sub>	random uncertainty	1,17

The standard uncertainties from table 46 should be combined by RSS in accordance with ETR 273 [12], part 1, subpart 1, clause 5. This gives the combined standard uncertainty ( $u_{c \text{ field measurement using a monopole}}$ ) for the field measurement using a monopole in dB.

The value of  $u_{c \text{ field measurement using a monopole}}$  is calculated as 1,91 dB.

#### 6.9.3.3.5 Expanded uncertainty for the receiver sensitivity measurement

The combined standard uncertainty of the results of the receiver sensitivity measurement is the combination of the components outlined in clauses 6.9.3.1.4 and 6.9.2.4.4. The components to be combined are  $u_{c \text{ measurement of the EUT}}$  and  $u_{c \text{ field measurement using a monopole}}$ .

$$u_c = \sqrt{2,18^2 + 1,91^2} = 2,90 \text{ dB}$$

The expanded uncertainty is  $\pm 1,96 \times 2,90 = \pm 5,68$  dB at a 95 % confidence level.

### 6.9.3.4 Uncertainty contributions: Stage 2: Field measurement using 3-axis probe

In this case, field measurement involves the use of a 3-axis probe and measuring the vertical component of the electric field.

#### 6.9.3.4.1 Contributions from the mismatch components

Whereas figure 41 shows schematically the equipment set-up for field measurement using a 3-axis probe, figure 42 provides a detailed picture of the individual uncertainty contributions.

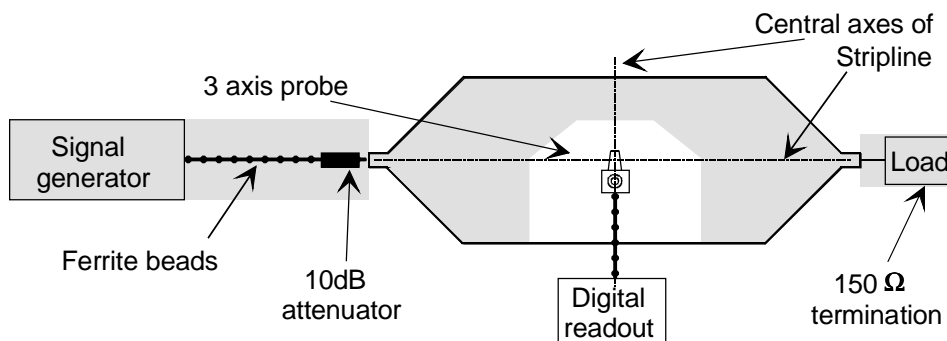

**Figure 41: Stage 2: Field measurement using a 3-axis probe**

**Mismatch: transmitting part:** The mismatch uncertainty between the signal generator, signal generator cable, signal generator attenuator and the Stripline input can be calculated from the approach described in annex G. The mismatch uncertainty through this network does, however, contribute equally to both stages of the test for cases in which a field strength measurement is subsequently performed since there are no changes from stage 1 to this part of the test set-up. The standard uncertainty of the contribution due to the mismatch in the transmitting part is designated throughout all parts of ETR 273 [12] as  $u_{j36}$ .

NOTE 1: In this example case the standard uncertainty of the contribution due to mismatch in the transmitting part is taken as 0,00 dB, since the uncertainty is systematic i.e. it produces the same offset in both stages.

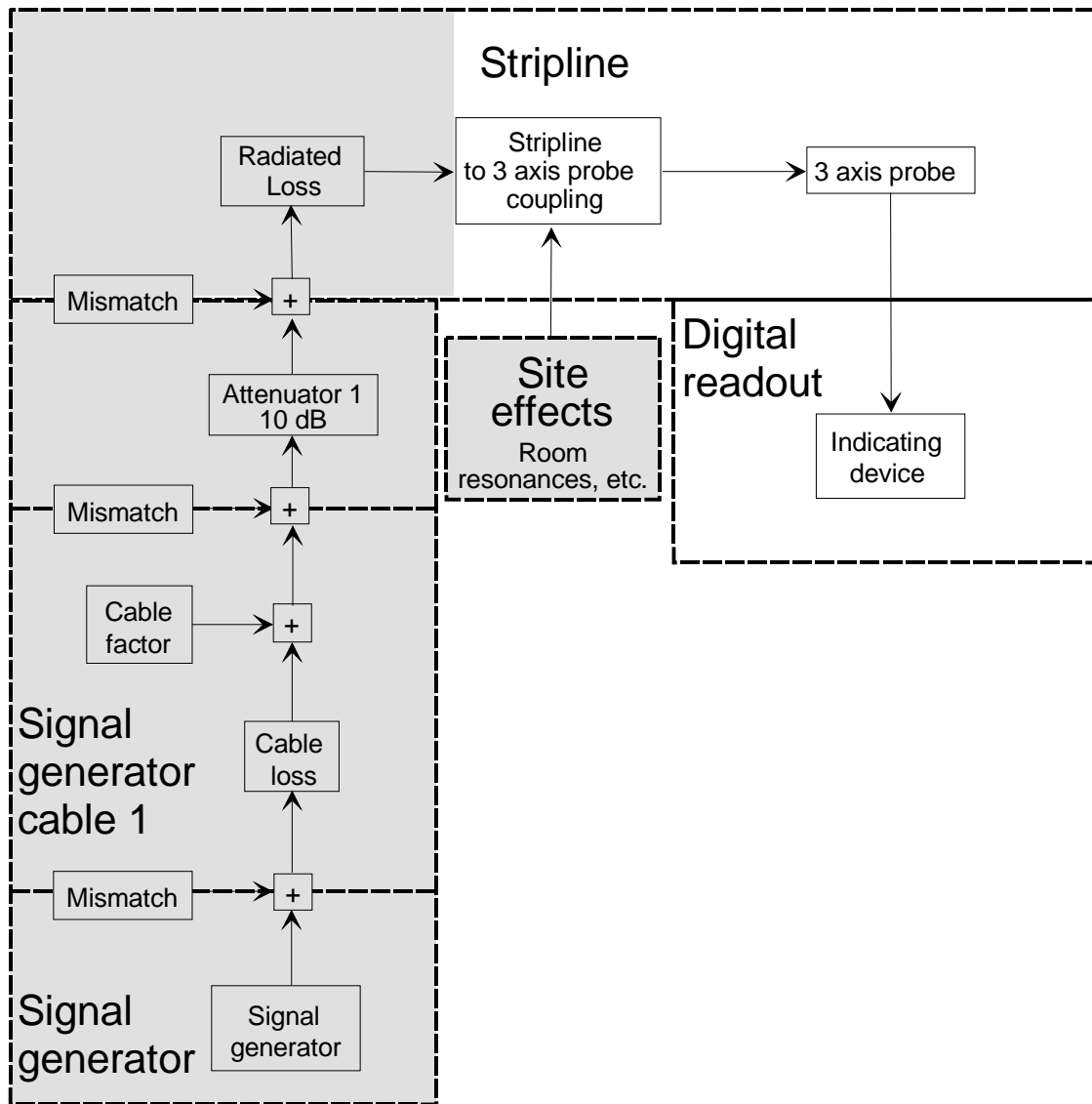

Figure 42: Schematic of the field measurement using a 3-axis probe

#### 6.9.3.4.2 Contributions from the individual components

##### 6.9.3.4.2.1 Signal generator

**Signal generator: absolute output level:** In this test method, the uncertainty due to the setting of the signal generator's absolute output level contributes to both stages. In stage 1, the output level is individually adjusted at each of 8 different positioning angles whilst in stage 2, after an inspection (or calculation) of the 8 different values, the signal generator is set to a specific output level. The standard uncertainty of the contribution due to the signal generator absolute output level uncertainty is designated throughout all parts of ETR 273 [12] as  $u_{j38}$ . Its value can be obtained from the manufacturer's data.

NOTE 1: In this example case the uncertainty of the contribution due to the signal generator absolute output level is obtained from the manufacturers data sheet as  $\pm 1,0$  dB. As nothing is said about the distribution of this uncertainty, a rectangular distribution (see ETR 273 [12], part 1, subpart 1, clause 5.1.2) in logs is assumed, and the standard uncertainty is calculated as 0,58 dB.

**Signal generator: output level stability:** In any test in which the contribution of the absolute level uncertainty of the signal generator contributes to the combined standard uncertainty of the test i.e. it does not cancel due to the methodology, the contribution from the output level stability is considered to have been included in the signal generator absolute output level,  $u_{j38}$ . Conversely, for any level in which the absolute level uncertainty of the signal generator does not contribute to the combined standard uncertainty, the output level stability of the signal generator should be included. The standard uncertainty of the contribution due to the signal generator output level stability is designated throughout all parts of ETR 273 [12] as  $u_{j39}$ . Its value can be derived from manufacturers' data sheet.

NOTE 2: In this example case the standard uncertainty of the contribution due to the signal generator output level stability is taken as 0,00 dB as it is covered by the absolute level uncertainty.

#### 6.9.3.4.2.2 Signal generator cable

**Insertion loss: signal generator cable:** The signal generator cable has an insertion loss as well as an uncertainty associated with the measurement of its magnitude. The value of insertion loss and its uncertainty remain valid provided the cable is not used outside the manufacturer's specification. At any given frequency the insertion loss acts as a systematic offset and contributes equally to both stages of the measurement. The standard uncertainty of the contribution due to the insertion loss uncertainty of the signal generator cable is designated throughout all parts of ETR 273 [12] as  $u_{j41}$ .

NOTE 1: In this example case the standard uncertainty of the contribution due to the insertion loss uncertainty of the signal generator cable is taken as 0,00 dB as a field strength measurement is performed using the 3-axis probe.

**Cable factor: signal generator cable:** Cable factor is defined as the total effect of the signal generator cable's influence on the measuring system including its interaction with the site. It consists of the leakage caused by cable screening inefficiency and introducing an unbalanced current into the Stripline. In a radiated measurement the standard uncertainty of the uncertainty due to cable factor, associated with each cable, is 0,5 dB provided that the precautions detailed in the methods have been observed. i.e. routing and dressing of cables with ferrites. If no prevention has been attempted the standard uncertainty is 4,0 dB (justification for these values is given in ETR 273 [12], part 1, subpart 2, annex E). The standard uncertainty of the contribution due to the cable factor of the signal generator cable is designated throughout all parts of ETR 273 [12] as  $u_{j19}$ .

NOTE 2: In this example case the standard uncertainty of the contribution due to the cable factor of the signal generator cable is taken as 0,00 dB since the precautions detailed in the methods have been observed and the field strength is to be measured.

#### 6.9.3.4.2.3 Signal generator attenuator

**Insertion loss: signal generator attenuator:** The signal generator attenuator has an insertion loss as well as an uncertainty associated with the measurement of its magnitude. The value of insertion loss and its uncertainty remain valid provided the attenuator is not used outside the manufacturer's specification. At any given frequency the insertion loss acts as a systematic offset and contributes equally to both stages of the measurement. The standard uncertainty of the contribution due to the insertion loss uncertainty of the signal generator attenuator is designated throughout all parts of ETR 273 [12] as  $u_{j40}$ .

NOTE: In this example case the standard uncertainty of the contribution due to the insertion loss uncertainty of the signal generator attenuator is 0,00 dB since the precautions detailed in the methods have been observed and the field strength is to be measured.

## 6.9.3.4.2.4 Site factors

**Ambient effect:** Uncertainty is introduced as a result of local ambient signals raising the noise floor at the measurement frequency. The standard uncertainty of the contribution due to the ambient effect is designated throughout all parts of ETR 273 [12] as  $u_{j34}$ . The values of the standard uncertainties should be taken from table 47.

**Table 47: Uncertainty contribution: Ambient effect**

Receiving device noise floor (generator OFF) is within:	Standard uncertainty of the contribution
3 dB of measurement	1,57 dB
3 dB to 6 dB of measurement	0,80 dB
6 dB to 10 dB of measurement	0,30 dB
10 dB to 20 dB of measurement	0,10 dB
20 dB or more of the measurement	0,00 dB

NOTE 1: In this example case the standard uncertainty of the contribution due to the ambient effect is taken as 0,00 dB since the Stripline is assumed to have been placed in a shielded room.

**Stripline: influence of site effects:** The influence of site effects comprise those effects, resulting from not observing the recommendations given in EN 55020 [16] regarding positioning of the Stripline and layout of absorber. These can lead to incorrect received levels i.e. values which differ from theoretical calculations. The standard uncertainty of the contribution due to the influence of site effects is designated throughout all parts of ETR 273 [12] as  $u_{j33}$ .

NOTE 2: In this example case the standard uncertainty of the contribution due to the influence of site effects is taken to be 0,00 dB since in this test method, site effects contribute equally to both stages as the recommendations are assumed to have been fully observed.

**Stripline: characteristic impedance:** This uncertainty contribution results from the difference between the free-space wave impedance ( $377 \Omega$ ) for which the 3-axis probe had been developed and that for the Stripline ( $150 \Omega$ ). The standard uncertainty of the contribution due to the characteristic impedance of the Stripline is designated throughout all parts of ETR 273 [12] as  $u_{j26}$ .

NOTE 3: In this example case the standard uncertainty of the contribution due to the characteristic impedance of the Stripline is taken as having a standard uncertainty of 0,58 dB.

**Stripline: mutual coupling of the 3-axis probe to its image in the plates:** This contribution is to take account of the fact that the probe has images in both plates of the Stripline. The standard uncertainty of the contribution due to the mutual coupling of the 3-axis probe to its image in the plates is designated throughout all parts of ETR 273 [12] as  $u_{j25}$ .

NOTE 4: In this example case the uncertainty of the contribution due to the mutual coupling of the 3-axis probe to its image in the plates is taken as  $\pm 0,5$  dB. As nothing is said about the distribution of this uncertainty, a rectangular distribution (see ETR 273 [12], part 1, subpart 1, clause 5.1.2) in logs is assumed, and the standard uncertainty is calculated as 0,29 dB.

## 6.9.3.4.2.5 3-axis probe field measurement

**Stripline: field strength measurement as determined by the 3-axis probe:** The standard uncertainty of the contribution, due to the field strength measurement uncertainty as determined by the 3-axis probe, is designated throughout all parts of ETR 273 [12] as  $u_{j28}$ . Its value can be derived from the manufacturers data sheet.

NOTE: In this example case the uncertainty of the contribution due to the field strength measurement as determined by the 3-axis probe is obtained from the manufacturer's data sheet as  $\pm 1$  dB. As nothing is said about the distribution of this uncertainty, a rectangular distribution (see ETR 273 [12], part 1, subpart 1, clause 5.1.2) in logs is assumed, and the standard uncertainty is calculated as 0,58 dB.

### 6.9.3.4.3 Contribution from the random component

**Random uncertainty:** The magnitude can be assessed from multiple measurements of the receiver sensitivity. The standard uncertainty of the contribution due to the random uncertainty is designated throughout all parts of ETR 273 [12] as  $u_{i01}$ .

The field strength measurement was repeated 10 times. The following results were obtained in dB $\mu$ V (before correcting for cabling and attenuator network insertion loss):

- 65,4; 63,4; 66,0; 65,3; 63,0; 64,9; 65,2; 66,8; 65,5; 63,7.

Converting to linear terms:

- $1,862 \times 10^{-3}$ ;  $1,479 \times 10^{-3}$ ;  $1,995 \times 10^{-3}$ ;  $1,841 \times 10^{-3}$ ;  $1,413 \times 10^{-3}$ ;  $1,758 \times 10^{-3}$ ;  $1,820 \times 10^{-3}$ ;  $2,188 \times 10^{-3}$ ;  $1,884 \times 10^{-3}$ ;  $1,531 \times 10^{-3}$ ;

The two sums  $X$  and  $Y$  are calculated:

- $X =$  the sum of the measured values =  $17,77 \times 10^{-3}$ ;
- $Y =$  the sum of the squares of the measured values =  $32,10 \times 10^{-6} \text{ V}^2$ .

$$u_{c \text{ random}} = \sqrt{\frac{Y - \frac{X^2}{n}}{n-1}} = \sqrt{\frac{32,10 \times 10^{-6} - \frac{(17,77 \times 10^{-3})^2}{10}}{10-1}} = 238,3 \times 10^{-6} \text{ (formula 5.6)}$$

As the result is obtained as the mean value of 10 measurements and the standard uncertainty of the random uncertainty is:

$$u_{j \text{ random}} = \frac{238,3 \times 10^{-6}}{1,777 \times 10^{-3}} \times \frac{100}{11,5} = 1,17 \text{ dB}$$

NOTE: In this example case the standard uncertainty of the contribution due to the random uncertainty is 1,17 dB.

### 6.9.3.4.4 Summary table of contributory components

A complete list of all the contributions to this part of the test method is given in table 48.

**Table 48: Contributions from the 3-axis probe field measurement**

U <sub>j</sub> or i	Description of uncertainty contributions	dB
U <sub>j36</sub>	mismatch: transmitting part	0,00
U <sub>j38</sub>	signal generator: absolute output level	0,58
U <sub>j39</sub>	signal generator: output level stability	0,00
U <sub>j41</sub>	insertion loss: signal generator cable	0,00
U <sub>j19</sub>	cable factor: signal generator cable	0,50
U <sub>j40</sub>	insertion loss: signal generator attenuator	0,00
U <sub>j34</sub>	ambient effect	0,00
U <sub>j33</sub>	Stripline: influence of site effects	0,00
U <sub>j26</sub>	Stripline: characteristic impedance	0,58
U <sub>j25</sub>	Stripline: mutual coupling of the 3-axis probe to its image in the plates	0,29
U <sub>j28</sub>	Stripline: field strength measurement as determined by the 3-axis probe	0,58
U <sub>i01</sub>	random uncertainty	1,17

The standard uncertainties from table 48 should be combined by RSS in accordance with ETR 273 [12], part 1, subpart 1, clause 5. This gives the combined standard uncertainty ( $u_{c \text{ 3-axis probe}}$ ) for the receiver sensitivity measurement in dB.

The value of  $u_{c \text{ 3-axis probe}}$  is calculated as 1,65 dB.

### 6.9.3.4.5 Expanded uncertainty for the receiver sensitivity measurement

The combined standard uncertainty of the results of the receiver sensitivity measurement is the combination of the components outlined in clauses 6.9.3.1.4 and 6.9.3.4.4. The components to be combined are  $u_{c \text{ EUT measurement}}$  and  $u_{c \text{ 3-axis probe}}$ .

$$u_c = \sqrt{2,18^2 + 1,65^2} = 2,73 \text{ dB}$$

The expanded uncertainty is  $\pm 1,96 \times 2,73 = \pm 5,36 \text{ dB}$  at a 95 % confidence level.

## 7 Transmitter measurement examples

The following pages of clause 7 show example measurement uncertainty calculations for a range of test configurations involving a variety of uncertainty contributions. Components essential for the measurement uncertainty calculations are shown in the accompanying drawings. Influence quantities (such as supply voltage and ambient temperature) are not shown in the drawings although they are present in the examples.

Symbols and abbreviations used in the examples are explained in clause 3.2 and clause 3.3. The test configuration, uncertainty contributions and the calculations are only examples and may not include all the possibilities. It is important that, where applicable, the errors are identified as either systematic or random for the purpose of making the calculations. Each example is calculated for a confidence level of 95 %.

Many of the calculations on the following pages have been reproduced in spreadsheet form to provide the reader with a structured and time-saving approach to calculating measurement uncertainty. The spreadsheets also allow the reader to make modifications to the calculations to meet individual needs where the effects of each contribution can be assessed more effectively. Where the related spreadsheet has been made available by ETSI, an appropriate reference has been included in the text.

### 7.1 Conducted

#### 7.1.1 Frequency error

##### a) Methodology

The signal to be measured is applied to a frequency counter via a power attenuator and the frequency read directly from the counter (see figure 43).

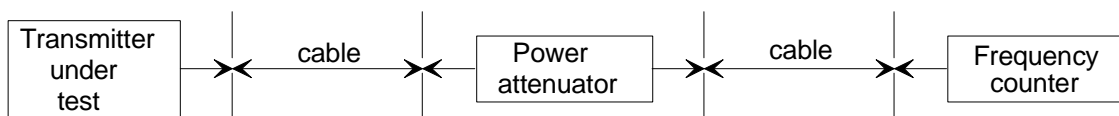

Figure 43: Frequency error measurement configuration

For the purposes of this example the nominal frequency is assumed to be 900 MHz (uncertainty will be expressed as an absolute value in Hz).

##### b) Measurement uncertainty

The time-base of the counter used has a drift of  $1 \times 10^{-9}$  per day. With a calibration period of less than 10 days, the time base uncertainty is less than  $1 \times 10^{-8}$ . The least significant digit is 10 Hz.

The manufacturers specification states that the overall uncertainty is time base uncertainty +3 counts of the least significant digit or 30 Hz whichever is the greater. The uncertainty of the frequency counter related to the measurement of 900 MHz is then:

- time base uncertainty =  $900 \times 10^6 \times 1 \times 10^{-8} = \pm 9 \text{ Hz}$  (d) (r);
- counter uncertainty =  $3 \times 10 \text{ Hz} = \pm 30 \text{ Hz}$  (d) (r).

There is also an uncertainty associated with the ambient temperature uncertainty. The dependency values found in table F.1 are:

- mean value of 0,02 ppm/°C;
- standard deviation of 0,01 ppm/°C.

This gives:

- $20 \times 10^{-9} \text{ Hz/}^\circ\text{C} \times 900 \times 10^6 = 18 \text{ Hz/}^\circ\text{C}$ ; and
- $10 \times 10^{-9} \text{ Hz/}^\circ\text{C} \times 900 \times 10^6 = 9 \text{ Hz/}^\circ\text{C}$ .

Ambient temperature uncertainty is  $\pm 3 \text{ }^\circ\text{C}$  (d) (r).

The standard uncertainty of the ambient temperature is:

$$u_{j \text{ tamb}} = \frac{3^\circ\text{C}}{\sqrt{3}} = 1,73^\circ\text{C}$$

The ambient temperature uncertainty is converted to a frequency uncertainty by means of formula 5.2.

$$u_{j \text{ ambient uncert}} = \sqrt{(1,73^\circ\text{C})^2 \times ((18 \text{ Hz/}^\circ\text{C})^2 + (9 \text{ Hz/}^\circ\text{C})^2)} = 34,8 \text{ Hz}$$

Finally the combined standard uncertainty is calculated:

$$u_{c \text{ frequency error}} = \sqrt{\frac{((9 \text{ Hz})^2 + (30 \text{ Hz})^2)}{3} + (34,8 \text{ Hz})^2} = 39,2 \text{ Hz}$$

Using an expansion factor (coverage factor) of  $k = 1,96$ , the expanded measurement uncertainty is  $\pm 1,96 \times 39,2 \text{ Hz} = \pm 76,8 \text{ Hz}$  (see annex D, clause D.5.6.2 in part 2).

### c) Spreadsheet implementation of measurement uncertainty

This calculation has been implemented in a corresponding spreadsheet (see file "Frequency error.xls") and is available in tr\_10002801v010301p0.zip.

## 7.1.2 Carrier power

### a) Methodology

The measurement is conducted using a power meter that consists of a thermocouple power sensor and a meter with a built in reference source. A 30 dB power attenuator is used to reduce the level applied to the sensor (see figure 44a). Before making the measurement, the loss of the cable and power attenuator are determined using a signal generator. The loss is measured by firstly connecting the generator to the power meter to obtain an arbitrary reference (see figure 44b). The cable and attenuator are then inserted between the sensor and generator and the loss determined (see figure 44c). Carrier power is recorded as the level measured on the power meter plus the measured correction for the cable and attenuator.

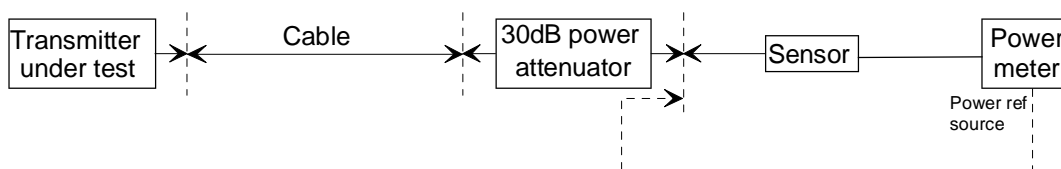

**Figure 44a: Carrier Power measurement configuration**

NOTE 1: An additional example of carrier power uncertainty involving two attenuators can be found in clause 6.4.

### b) Measurement uncertainty



**i) Power meter and sensor:**

power meter reference source level uncertainty is  $\pm 1,2\%$  (p) (d) (r).

$$u_{j \text{ reference level}} = \frac{1,2}{\sqrt{3} \times 23,0} = 0,03dB$$

Calibration factor uncertainty =  $\pm 2,3\%$  (p) (d) (r).

$$u_{j \text{ calibration factor}} = \frac{2,3}{\sqrt{3} \times 23,0} = 0,058dB$$

Range change error (one change) =  $\pm 0,5\%$  (p) (d) (r).

$$u_{j \text{ range change}} = \frac{0,5}{\sqrt{3} \times 23,0} = 0,013dB$$

Linearity factor =  $\pm 0,5\%$  (p) (d) (r).

$$u_{j \text{ linearity factor}} = \frac{0,5}{\sqrt{3} \times 23,0} = 0,013dB$$

Mismatch uncertainty when calibrating:

- reference source  $VSWR_g = 1,05$  (d) so reflection coefficient = 0,024;
- sensor input  $VSWR_s = 1,15$  (d) so reflection coefficient = 0,070.

$$u_{j \text{ calibration mismatch}} = \frac{0,024 \times 0,07 \times 100}{\sqrt{2} \times 11,5} = 0,01dB$$

Noise and drift is negligible at this power level and can be ignored.

$$u_{c \text{ power meter and sensor}} = \sqrt{u_{j \text{ ref level}}^2 + u_{j \text{ cal factor}}^2 + u_{j \text{ range change}}^2 + u_{j \text{ lin factor}}^2 + u_{j \text{ cal mismatch}}^2}$$

$$u_{c \text{ power meter and sensor}} = \sqrt{0,03^2 + 0,058^2 + 0,013^2 + 0,013^2 + 0,01^2} = 0,069dB$$

**ii) Uncertainty when measuring the attenuator/cable loss:**

**Figure 44b: Determining the reference level**

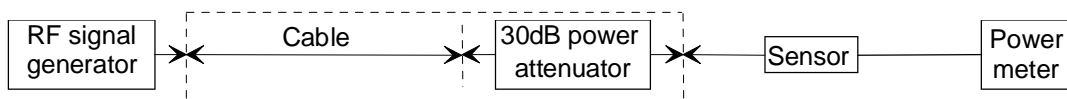

**Figure 44c: measuring the attenuator and cable loss**

**Mismatch uncertainty:**

- generator reflection coefficient is 0,07 (d);
- sensor reflection coefficient is 0,07 (d);
- cable reflection coefficients are 0,14 (d);
- attenuator reflection coefficients are 0,13 (d).

For the calculation of mismatch uncertainty the cable attenuation is assumed to be 0 dB (x1 linear).

The mismatch uncertainty is comprised of two parts:

PART 1 - the reference measurement, this is when the generator and sensor are connected together (see figure 44b):

$$u_{j \text{ mismatch: reference measurement}} = \frac{0,07 \times 0,07 \times 100}{\sqrt{2} \times 11,5} = 0,030 \text{ dB}$$

PART 2 - the attenuation measurement, this is when the cable and attenuator are placed between the generator and sensor (see figure 44c). Mismatch components appear at the generator/cable junction and the attenuator/sensor junction:

$$u_{j \text{ mismatch: generator to cable}} = \frac{0,07 \times 0,14 \times 100}{\sqrt{2} \times 11,5} = 0,060 \text{ dB}$$

$$u_{j \text{ mismatch: attenuator to sensor}} = \frac{0,13 \times 0,07 \times 100}{\sqrt{2} \times 11,5} = 0,056 \text{ dB}$$

$$u_{j \text{ mismatch: generator to attenuator}} = \frac{0,07 \times 0,13 \times 1^2 \times 100}{\sqrt{2} \times 11,5} = 0,056 \text{ dB}$$

NOTE 2: The remaining mismatch contributions have a negligible effect due to the isolating effect of the 30dB attenuator and have therefore been ignored.

The total mismatch uncertainty during the cable/attenuator measurement is:

$$u_{c \text{ mismatch: attenuation measurement}} = \sqrt{u_{j \text{ reference measurement}}^2 + u_{j \text{ generator to cable}}^2 + u_{j \text{ atten to sensor}}^2 + u_{j \text{ generator to sensor}}^2}$$

$$u_{c \text{ mismatch: attenuation measurement}} = \sqrt{0,030^2 + 0,060^2 + 0,056^2 + 0,056^2} = 0,104 \text{ dB}$$

**The 30dB attenuator will reduce the level at the sensor so:**

$$u_{c \text{ cable and attenuator measurement}} = \sqrt{u_{j \text{ range change error}}^2 + u_{j \text{ linearity factor}}^2 + u_{c \text{ mismatch: attenuation measurement}}^2}$$

$$u_{c \text{ cable and attenuator measurement}} = \sqrt{0,013^2 + 0,013^2 + 0,104^2} = 0,106 \text{ dB}$$

**iii) Carrier power measurement (see fig 44a):**

**Attenuator uncertainty:**

Temperature influence = 0,0001 dB/degree which is negligible and can be ignored.

Power influence on the attenuator is 0,001 dB/dB x Watt (d) (r) = 0,001 x 30 x 25 = 0,75 dB (r):

$$u_{j \text{ power influence}} = \frac{0,75}{\sqrt{3}} = 0,433 \text{ dB}$$

**Mismatch uncertainty:**

- transmitter reflection coefficient is 0.5 (taken from table F.1);
- cable reflection coefficients are 0,14 (d);
- attenuator reflection coefficients are 0,13 (d);
- sensor reflection coefficient is 0,07 (d).

For the calculation of mismatch uncertainty the cable attenuation is assumed to be 0 dB (x 1 linear).

$$u_{j \text{ mismatch: EUT to cable}} = \frac{0,5 \times 0,14 \times 100\%}{\sqrt{2} \times 11,5} = 0,430 \text{ dB}$$

$$u_{j \text{ mismatch: EUT to attenuator}} = \frac{0,5 \times 0,13 \times 1^2 \times 100\%}{\sqrt{2} \times 11,5} = 0,400 \text{ dB}$$

$$u_{j \text{ mismatch: attenuator to sensor}} = \frac{0,13 \times 0,07 \times 100\%}{\sqrt{2} \times 11,5} = 0,056 \text{ dB}$$

The total mismatch uncertainty during the power measurement is:

$$u_{c \text{ mismatch: power measurement}} = \sqrt{u_{j \text{ EUT to cable}}^2 + u_{j \text{ EUT to attenuator}}^2 + u_{j \text{ attenuator to sensor}}^2}$$

$$u_{c \text{ mismatch: power measurement}} = \sqrt{0,430^2 + 0,400^2 + 0,056^2} = 0,60 \text{ dB}$$

NOTE 3: The remaining mismatch contributions have a negligible effect due to the isolating effect of the 30dB attenuator and have therefore been ignored.

### Uncertainty due to influence quantities:

Ambient temperature = 20°C ± 1°C (d) (r).

The ambient temperature uncertainty is converted to a level uncertainty by means of formula 5.2 and table F.1. Dependency values found in table F.1 are:

- mean of 4 % power/°C;
- standard deviation of 1,2 % power/°C.

Therefore:

$$u_{j \text{ temperature uncertainty}} = \frac{\sqrt{\left(\frac{(1^\circ\text{C})^2}{3}\right) \times ((4,0 \text{ \%}/^\circ\text{C})^2 + (1,2 \text{ \%}/^\circ\text{C})^2)}}{23} = 0,1 \text{ dB}$$

Supply voltage =  $V_{\text{set}} \pm 100 \text{ mV}$  (d) (r).

The supply voltage uncertainty is converted to a level uncertainty by means of formula 5.2 and table F.1. Dependency values found in table F.1 are:

- mean value of 10 % power/V;
- standard deviation of 3 % power/V.

Therefore:

$$u_{j \text{ supply voltage uncertainty}} = \frac{\sqrt{\left(\frac{(0,1\text{V})^2}{3}\right) \times ((10 \text{ \%}/\text{V})^2 + (3 \text{ \%}/\text{V})^2)}}{23} = 0,026 \text{ dB}$$

### Random uncertainty:

The measurement was repeated 9 times with the following results:

- 21,8 mW; 22,8 mW; 23,0 mW; 22,5 mW; 22,1 mW; 22,7 mW; 21,7 mW; 22,3 mW; 22,7 mW.

Mean value = 22,4 mW, standard deviation = 0,455 mW.

As the result is obtained as the mean value of 9 measurements the normalized standard deviation of the random uncertainty is:

$$u_{i \text{ random}} = \frac{0,455 \text{ mW}}{22,4 \text{ mW} \times \sqrt{9} \times 23,0} \times 100\% = 0,03 \text{ dB}$$

### Uncertainty due to time duty cycle:

The standard uncertainty of the time duty cycle error (found in table F.1) = 2 % (p) ( $\sigma$ ).

$$u_{j \text{ time duty cycle}} = \frac{2\%}{23,0} = 0,087 \text{ dB}$$

$$u_{\text{c power measurement t}} = \sqrt{u_{\text{j pwr influence}}^2 + u_{\text{c mismatch: Power measurement t}}^2 + u_{\text{j temp}}^2 + u_{\text{j supply voltage}}^2 + u_{\text{i random}}^2 + u_{\text{j time duty cycle}}^2}$$

$$u_{\text{c power measurement t}} = \sqrt{0,433^2 + 0,6^2 + 0,1^2 + 0,026^2 + 0,03^2 + 0,087^2} = 0,75 \text{ dB}$$

### The combined standard uncertainty for carrier power is:

$$u_{\text{c carrier power}} = \sqrt{u_{\text{c power meter \& sensor}}^2 + u_{\text{c cable \& attenuator measurement t}}^2 + u_{\text{c power measurement t}}^2}$$

$$u_{\text{c carrier power}} = \sqrt{0,069^2 + 0,106^2 + 0,75^2} = 0,76 \text{ dB}$$

Using an expansion factor (coverage factor) of  $k = 1,96$ , the expanded measurement uncertainty is  $\pm 1,96 \times 0,76 \text{ dB} = \pm 1,49 \text{ dB}$  (see annex D, clause D.5.6.2 in part 2).

### c) Spreadsheet implementation of measurement uncertainty

This calculation has been implemented in a corresponding spreadsheet (see file "Carrier power\_Rev1.xls") and is available in tr\_10002801v010301p0.zip.

## 7.1.3 Adjacent channel power

### 7.1.3.1 Adjacent channel power method 1 (Using an adjacent channel power meter)

#### a) Methodology

The transmitter under test is connected to an adjacent channel power meter (power measuring receiver) via an attenuator (see figure 45).

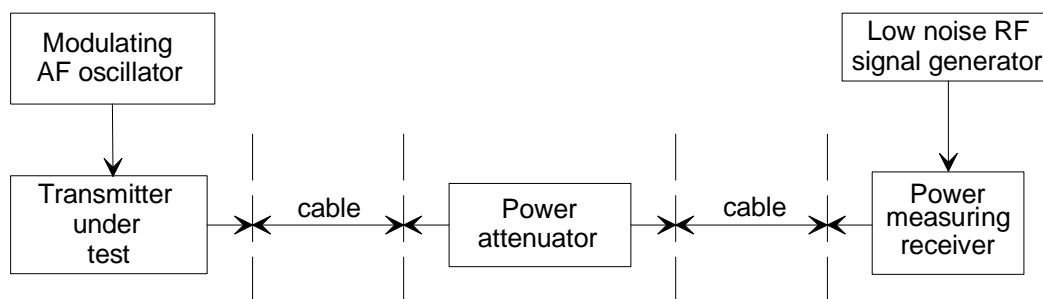

Figure 45: Measurement configuration for adjacent channel power measurement (method 1)

#### b) Measurement uncertainty

Power bandwidth of measuring receiver filter =  $\pm 0,2 \text{ dB}$  (d) (r).

$$u_{j \text{ filter bandwidth}} = \frac{\pm 0,20}{\sqrt{3}} = 0,115 \text{ dB}$$

Relative accuracy of measuring receiver =  $\pm 0,5 \text{ dB}$  (d) (r).

$$u_{j \text{ relative accuracy}} = \frac{\pm 0,50}{\sqrt{3}} = 0,289 \text{ dB}$$

Standard uncertainty of the random error = 0,11 dB ( $\sigma$ ).

$$u_{i \text{ random}} = 0,11 \text{ dB}$$

Deviation uncertainty =  $\pm 30$  Hz (d) (r).

Deviation uncertainty is converted to a relative adjacent channel power uncertainty by means of formula 5.2 and table F.1. Dependency values found in table F.1 are:

- mean value of 0,05 % (p) / Hz;
- standard deviation of 0,02 % (p) / Hz.

Therefore:

$$u_{j \text{ converted deviation}} = \frac{\sqrt{\left(\frac{(30 \text{ Hz})^2}{3}\right) \times \left((0,05 \% / \text{Hz})^2 + (0,02 \% / \text{Hz})^2\right)}}{23,0} = 0,04 \text{ dB}$$

Uncertainty caused by measuring receiver filter position.

Uncertainty of 6 dB point =  $\pm 75$  Hz (d) (r).

The uncertainty of the 6dB point is converted to a relative adjacent channel power uncertainty by means of formula 5.2 and table F.1. Dependency values found in table F1 are:

- mean value of 15 dB/kHz;
- standard deviation of 4 dB/kHz.

Therefore:

$$u_{j \text{ converted filter position}} = \sqrt{\left(\frac{(0,075 \text{ kHz})^2}{3}\right) \times \left((15 \text{ dB/kHz})^2 + (4 \text{ dB/kHz})^2\right)} = 0,67 \text{ dB}$$

$$u_{c \text{ adjacent channel power}} = \sqrt{u_{j \text{ filter pwr bw}}^2 + u_{j \text{ relative accuracy}}^2 + u_{i \text{ random}}^2 + u_{j \text{ converted dev}}^2 + u_{j \text{ converted filter pos}}^2}$$

$$u_{c \text{ adjacent channel power}} = \sqrt{0,115^2 + 0,289^2 + 0,11^2 + 0,04^2 + 0,67^2} = 0,748 \text{ dB}$$

Using an expansion factor (coverage factor) of  $k = 1,96$ , the expanded measurement uncertainty is  $\pm 1,96 \times 0,748$  dB =  $\pm 1,47$  dB (see annex D, clause D.5.6.2 in part 2).

### c) Spreadsheet implementation of measurement uncertainty

This calculation has been implemented in a corresponding spreadsheet (see file "Adjacent channel power (method 1).xls") and is available in tr\_10002801v010301p0.zip.

## 7.1.3.2 Adjacent channel power method 2 (Using a spectrum analyser)

### a) Methodology

The transmitter under test is connected to a spectrum analyser via a power attenuator (see figure 46) and the carrier is recorded as reference.

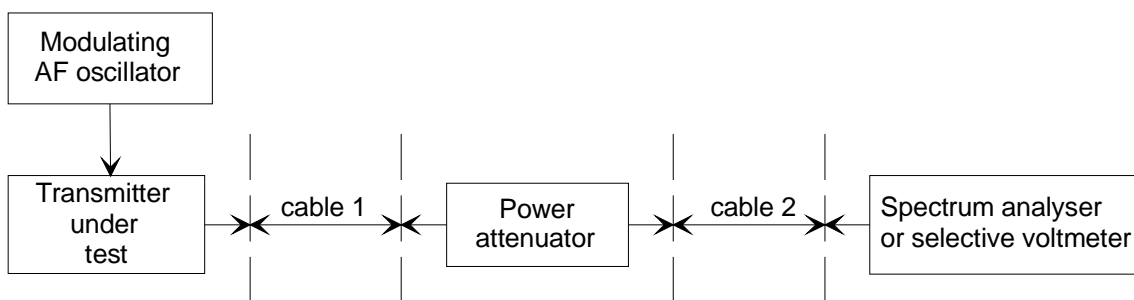

**Figure 46: Measurement configuration for adjacent channel power (method 2)**

The adjacent channel power is calculated from the spectrum analyser readings (9 samples) by means of Simpson's Rule (area under the curve).

#### b) Measurement uncertainty

##### Reference level (carrier power) uncertainty:

Spectrum analyser log fidelity =  $\pm 1$  dB (d) (r) (carrier level may be measured below the analyser reference level).

$$u_{j \log \text{ fidelity (ref level)}} = \frac{\pm 1,00}{\sqrt{3}} = 0,577 \text{ dB}$$

RBW switching =  $\pm 0,5$  dB (d) (r).

$$u_{j \text{ RBW switching}} = \frac{\pm 0,50}{\sqrt{3}} = 0,289 \text{ dB}$$

##### Uncertainty of calculation caused by log fidelity (adjacent channel):

(The circles on figure 47 show the readings).

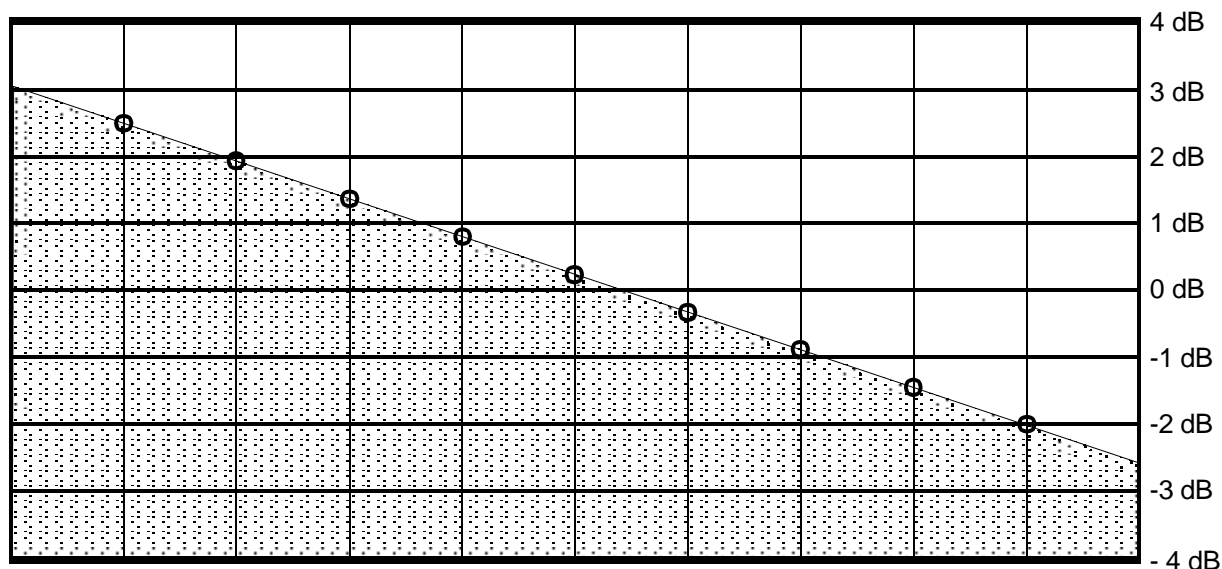

**Figure 47: Typical screen view**

Spectrum analyser log fidelity is a maximum of  $\pm 1,0$  dB (d). Since the measured result is a sum of many contributions, where the error can lie anywhere between  $\pm 1$  dB, the combined error is assumed to be a Gaussian distribution, and the  $\pm 1,0$  dB limits are assumed to be  $3\sigma$ . The standard uncertainty is therefore  $1/3 = 0,33$  dB.

$$u_{j \log \text{ fidelity (calculation)}} = 0,33 \text{ dB}$$

**Random uncertainty:**

Standard uncertainty of the random error is  $\pm 0,11$  dB (m) ( $\sigma$ ).

$$u_{i\text{random}} = 0,11\text{dB}$$

**Deviation uncertainty:**

Deviation uncertainty is  $\pm 30$  Hz (d) (r).

Deviation uncertainty is converted to a level uncertainty by means of formula 5.2 and table F.1. Dependency values found in table F1 are:

- mean of 0,05 % (p)/Hz;
- standard deviation of 0,02 % (p)/Hz.

Therefore:

$$u_{j\text{converted deviation}} = \frac{\sqrt{\left(\frac{(30\text{ Hz})^2}{3}\right) \times ((0,05\%/\text{Hz})^2 + (0,02\%/\text{Hz})^2)}}{23,0} = 0,04\text{dB}$$

**Time-duty cycle:**

Time-duty-cycle uncertainty (from table F.1): Standard deviation = 2,0 % (p).

$$u_{jTDC} = \frac{2,0}{23,0} = 0,087\text{dB}$$

**The combined standard uncertainty for adjacent channel power is:**

$$u_{c\text{ adjacent channel power}} = \sqrt{u_{j\text{ log fidelity (ref level)}}^2 + u_{j\text{ RBW switching}}^2 + u_{j\text{ log fidelity (calculation)}}^2 + u_{i\text{ random}}^2 + u_{j\text{ converted deviation}}^2 + u_{jTDC}^2}$$

$$u_{c\text{ adjacent channel power}} = \sqrt{0,577^2 + 0,289^2 + 0,33^2 + 0,11^2 + 0,04^2 + 0,087^2} = 0,74\text{dB}$$

Using an expansion factor (coverage factor) of  $k = 1,96$ , the expanded measurement uncertainty is  $\pm 1,96 \times 0,74$  dB =  $\pm 1,45$  dB (see annex D, clause D.5.6.2 in part 2).

## 7.1.4 Conducted spurious emissions

### 7.1.4.1 Direct reading method

**a) Methodology**

A spectrum analyser is calibrated from its internal reference source using a cable with negligible loss at the calibration reference frequency. The transmitter under test is then connected to the spectrum analyser via a 30 dB attenuator and filter (see figure 48a), and an absolute reading for each spurious emission obtained on the analyser. The levels are corrected for attenuator loss, filter loss, and cable loss (which becomes significant at the higher spurious frequencies) and recorded as the results for a direct reading. For this example, measurement uncertainty must include components of uncertainty for the spectrum analyser, cable loss and various mismatches between the transmitter, cables, attenuator, filter and spectrum analyser.

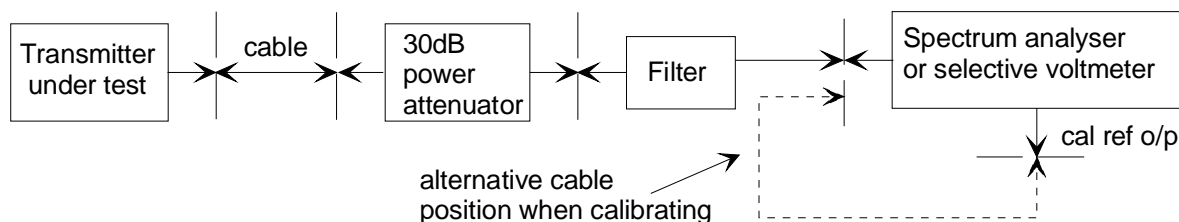

**Figure 48a: Conducted spurious emission measurement configuration (direct method)**

### b) Measurement uncertainty: Direct method

#### Mismatch uncertainty when calibrating the spectrum analyser:

- spectrum analyser calibration reference output reflection coefficient is 0,2 (d);
- spectrum analyser RF input reflection coefficient is 0,1 (d);
- calibration cable reflection coefficient is 0,2 (m).

For calculation of mismatch, attenuation of the calibration cable is assumed to be 0,00dB (x1 linear).

$$u_{j \text{ mismatch: calibration reference output and cable}} = \frac{0,2 \times 0,2 \times 100\%}{\sqrt{2}} = 2,828\% (v)$$

$$u_{j \text{ mismatch: spectrum analyser input and cable}} = \frac{0,1 \times 0,2 \times 100\%}{\sqrt{2}} = 1,414\% (v)$$

$$u_{j \text{ mismatch: spectrum analyser input and spectrum analyser cal output}} = \frac{0,1 \times 0,2 \times (1,0)^2 \times 100\%}{\sqrt{2}} = 1,414\% (v)$$

The combined standard uncertainty for mismatch during calibration is:

$$u_{c \text{ mismatch: calibration}} = \sqrt{2,828^2 + 1,414^2 + 1,414^2} = 3,464\% (v)$$

#### Mismatch uncertainty when measuring the transmitter spurious:

- transmitter reflection coefficient is 0,7 (from table F1);
- measurement cable reflection coefficients are 0,2 (m);
- attenuator reflection coefficients are 0,1 (d);
- filter reflection coefficients are 0,3 (d);
- spectrum analyser RF input reflection coefficient is 0,1 (d).

For the calculation of mismatch, measurement cable attenuation is assumed to be 0,00 dB (x1,0 linear) and filter insertion loss is 1 dB (x 0,891 linear).

$$u_{j \text{ mismatch : transmitter and cable}} = \frac{0,7 \times 0,2 \times 100\%}{\sqrt{2}} = 9,899\% (v)$$

$$u_{j \text{ mismatch : cable and attenuator}} = \frac{0,2 \times 0,1 \times 100\%}{\sqrt{2}} = 1,414\% (v)$$

$$u_{j \text{ mismatch : attenuator and filter}} = \frac{0,1 \times 0,3 \times 100\%}{\sqrt{2}} = 2,121\% (v)$$

$$u_{j \text{ mismatch : filter and spectrum analyser}} = \frac{0,3 \times 0,1 \times 100\%}{\sqrt{2}} = 2,121\% (v)$$



$$u_{j \text{ mismatch : transmitter and attenuator}} = \frac{0,7 \times 0,1 \times (1,0)^2 \times 100\%}{\sqrt{2}} = 4,950 \% (v)$$

$$u_{j \text{ mismatch : attenuator and spectrum analyser}} = \frac{0,1 \times 0,1 \times (0,891)^2 \times 100\%}{\sqrt{2}} = 0,561 \% (v)$$

$u_{j \text{ mismatch: EUT and filter}}$ : Less than 0,01 % (v) due to the 30 dB attenuator, therefore neglected.

$u_{j \text{ mismatch: EUT and spectrum analyser}}$ : Less than 0,01 % (v) due to the 30 dB attenuator, therefore neglected.

The combined standard uncertainty for mismatch with the transmitter connected is:

$$u_{c \text{ mismatch : transmitter connected}} = \sqrt{9,899^2 + 1,414^2 + 2,121^2 + 2,121^2 + 4,950^2 + 0,561^2} = 11,567 \% (v)$$

The combined standard uncertainty for total mismatch is:

$$u_{c \text{ mismatch total}} = \frac{\sqrt{3,464^2 + 11,567^2}}{11,5} = 1,05 \text{ dB}$$

### Uncertainty when making the measurement on the spectrum analyser:

Spectrum analyser calibration reference uncertainty =  $\pm 0,3$  dB (d) (r).

$$u_{j \text{ cal ref}} = \frac{0,3}{\sqrt{3}} = 0,173 \text{ dB}$$

Spectrum analyser frequency response uncertainty =  $\pm 2,5$  dB (d) (r).

$$u_{j \text{ frequency response}} = \frac{2,5}{\sqrt{3}} = 1,443 \text{ dB}$$

Spectrum analyser bandwidth switching uncertainty =  $\pm 0,5$  dB (d) (r).

$$u_{j \text{ bandwidth switching}} = \frac{0,5}{\sqrt{3}} = 0,289 \text{ dB}$$

Spectrum analyser log fidelity =  $\pm 1,5$  dB (d) (r).

$$u_{j \text{ log fidelity}} = \frac{1,5}{\sqrt{3}} = 0,866 \text{ dB}$$

Spectrum analyser input attenuator switching uncertainty =  $\pm 0,2$  dB (d) (r).

$$u_{j \text{ input att switching}} = \frac{0,2}{\sqrt{3}} = 0,115 \text{ dB}$$

Attenuator loss uncertainty =  $\pm 0,15$  dB (d) (r).

$$u_{j \text{ atten loss}} = \frac{0,15}{\sqrt{3}} = 0,087 \text{ dB}$$

Filter loss uncertainty =  $\pm 0,15$  dB (d) (r).

$$u_{j \text{ filter loss}} = \frac{0,15}{\sqrt{3}} = 0,087 \text{ dB}$$

Power coefficient of the attenuator =  $\pm 0,3$  dB (c) (r).

$$u_{j \text{ att pwr coef}} = \frac{0,3}{\sqrt{3}} = 0,173 \text{ dB}$$

Standard uncertainty of measurement cable =  $\pm 0,2$  dB (m) ( $\sigma$ ).

$$u_{j\text{cable}} = 0,2\text{dB}$$

Random uncertainty =  $\pm 0,2$  dB (m) ( $\sigma$ ).

$$u_{i\text{random}} = 0,2\text{dB}$$

### Uncertainty due to supply voltage:

Supply voltage uncertainty =  $\pm 100$  mV (d) (r).

Supply voltage uncertainty is converted to a level uncertainty by means of formula 5.2 and table F.1. Dependency values found in table F.1 are:

- mean value of 10 % (p)/V;
- standard deviation of 3 % (p)/V.

Therefore:

$$u_{j\text{converted supply voltage}} = \frac{\sqrt{\left(\frac{(0,1\text{V})^2}{3}\right) \times \left((10,0\%/V)^2 + (3,0\%/V)^2\right)}}{23,0} = 0,026\text{dB}$$

The combined standard uncertainty is:

$$u_{c\text{tot}} = \sqrt{u_{j\text{miu}}^2 + u_{j\text{cal}}^2 + u_{j\text{fr}}^2 + u_{j\text{bw}}^2 + u_{j\text{logf}}^2 + u_{j\text{attsw}}^2 + u_{j\text{attloss}}^2 + u_{j\text{filter}}^2 + u_{j\text{attcoef}}^2 + u_{j\text{cable}}^2 + u_{i\text{rnd}}^2 + u_{j\text{vcc}}^2}$$

$$u_{c\text{tot}} = \sqrt{1,05^2 + 0,173^2 + 1,443^2 + 0,289^2 + 0,866^2 + 0,115^2 + 0,087^2 + 0,087^2 + 0,173^2 + 0,2^2 + 0,2^2 + 0,026^2} = 2,05\text{dB}$$

Using an expansion factor (coverage factor) of  $k = 1,96$ , the expanded measurement uncertainty is  $\pm 1,96 \times 2,05$  dB =  $\pm 4,02$  dB (see annex D, clause D.5.6.2 in part 2).

### c) Spreadsheet implementation of measurement uncertainty

This calculation has been implemented in a corresponding spreadsheet (see file 'Tx conducted spurious emissions (direct).xls') and is available in tr\_10002801v010301p0.zip.

## 7.1.4.2 Substitution method

### a) Methodology

In order to reduce measurement uncertainty, a signal generator may be substituted for the transmitter and the level from the generator increased until the same reading (as obtained with the transmitter) is measured on the analyser. The signal generator output level is then recorded as the result using substitution. In this case, the large uncertainty of the spectrum analyser is replaced with the much lower uncertainty of the signal generator, and the attenuator, filter and cable uncertainties can be ignored since they are common to both measurements.

NOTE 1: In some cases the maximum signal generator level will be less than the transmitter spurious level, and the substitution reading will be obtained from a different point on the spectrum analyser display (using the analyser's dynamic range). For this reason the spectrum analyser log fidelity uncertainty has been included in the calculation.

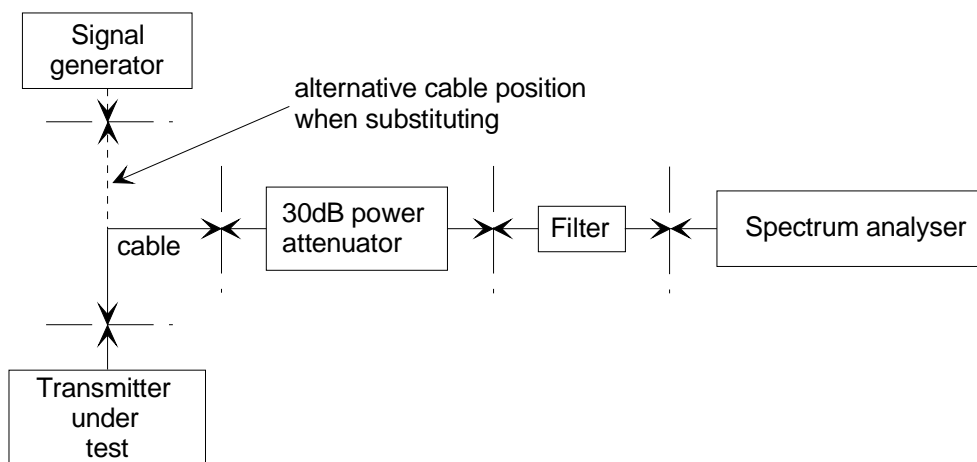

Figure 48b: Conducted spurious emissions measurement configuration (substitution method)

### b) Measurement uncertainty: Substitution method

#### Mismatch uncertainty:

The 30 dB attenuator is large enough to provide good isolation between the transmitter (or signal generator) and the filter. Thus the only mismatch uncertainty of interest is at the input to the attenuator. The rest cancel due to substitution:

- transmitter reflection coefficient is 0,7 (from table F1);
- measurement cable reflection coefficients are 0,2 (m);
- attenuator input reflection coefficient is 0,1 (d);
- signal generator output reflection coefficient is 0,35 (d).

For the calculation of mismatch, cable attenuation is assumed to be 0,00 dB (x 1 linear).

$$u_{jmismatch:Tx\ to\ cable} = \frac{0,7 \times 0,2 \times 100\%}{\sqrt{2}} = 9,899\% (v)$$

$$u_{jmismatch:cable\ to\ attenuator} = \frac{0,2 \times 0,1 \times 100\%}{\sqrt{2}} = 1,414\% (v)$$

$$u_{jmismatch:Tx\ to\ attenuator} = \frac{0,7 \times 0,1 \times (1,0^2) \times 100\%}{\sqrt{2}} = 4,950\% (v)$$

$$u_{jmismatch:sig\ gen\ to\ cable} = \frac{0,35 \times 0,2 \times 100\%}{\sqrt{2}} = 4,950\% (v)$$

$$u_{jmismatch:sig\ gen\ to\ attenuator} = \frac{0,35 \times 0,1 \times (1,0^2) \times 100\%}{\sqrt{2}} = 2,475\% (v)$$

The combined standard uncertainty for mismatch is:

$$u_{cmismatch} = \frac{\sqrt{9,899^2 + 1,414^2 + 4,950^2 + 4,950^2 + 2,475^2}}{11,5} = 1,083\text{dB}$$

#### Uncertainty when making the measurement:

Substitution signal generator level uncertainty is  $\pm 1$  dB (d) (r).

$$u_{jsig\ gen\ level} = \frac{\pm 1,0}{\sqrt{3}} = 0,577\text{dB}$$

Spectrum analyser log fidelity (where signal generator is unable to produce sufficient level) =  $\pm 1,5$  dB (d) (r).

$$u_{j \log \text{ fidelity}} = \frac{1,5}{\sqrt{3}} = 0,866 \text{ dB}$$

Random uncertainty is 0,2 dB (m) ( $\sigma$ ).

#### Uncertainty due to supply voltage:

Supply voltage uncertainty =  $\pm 100$  mV (d) (r).

Supply voltage uncertainty is converted to a level uncertainty by means of formula 5.2 and table F.1. Dependency values found in table F.1 are:

- mean value of 10 % (p)/V;
- standard deviation of 3 % (p)/V.

Therefore:

$$u_{j \text{ converted supply voltage}} = \frac{\sqrt{\left(\frac{(0,1 \text{ V})^2}{3}\right) \times \left((10,0\% / V)^2 + (3,0\% / V)^2\right)}}{23,0} = 0,026 \text{ dB}$$

#### The combined standard uncertainty is:

$$u_{c \text{ conducted spurious emission}} = \sqrt{u_{c \text{ mismatch}}^2 + u_{j \text{ sig gen level}}^2 + u_{j \text{ log fidelity}}^2 + u_{i \text{ random}}^2 + u_{j \text{ supply voltage uncert}}^2}$$

$$u_{c \text{ conducted spurious emissions}} = \sqrt{1,083^2 + 0,577^2 + 0,866^2 + 0,2^2 + 0,026^2} = 1,52 \text{ dB}$$

Using an expansion factor (coverage factor) of  $k = 1,96$ , the expanded measurement uncertainty is  $\pm 1,96 \times 1,52 \text{ dB} = \pm 2,98 \text{ dB}$  (see annex D, clause D.5.6.2 in part 2).

NOTE 2: The substitution example has a far lower measurement uncertainty than the direct example.

### 7.1.5 Intermodulation attenuation

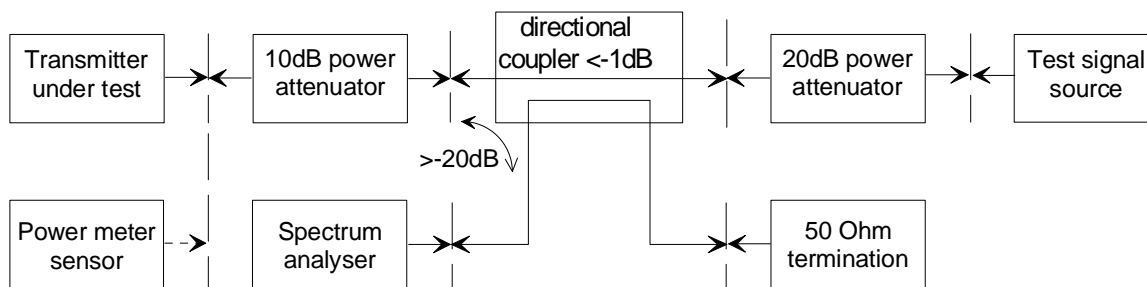

**Figure 49: Intermodulation attenuation**

The transmitter power is first measured on the power meter. The power meter is then connected to the 10 dB attenuator (the connector which during the actual measurement is connected to the transmitter output) and the power meter reading set to -30 dB (relative) by adjusting the level of test signal source. With the transmitter reconnected to the 10 dB attenuator, the intermodulation component is then measured by direct observation on the spectrum analyser, and the ratio of the largest intermodulation component to the carrier is recorded. As this is a relative measurement, uncertainties due to the spectrum analyser (with the exception of log fidelity) cancel, and can be ignored.

**b) Measurement uncertainty:****Uncertainty when measuring the transmitter level and setting the level of the test signal source to -30 dB relative:**

NOTE: The power meter is only used to set the test signal source to -30 dB relative to the transmitter level so only range change and linearity need to be considered.

Power meter linearity =  $\pm 0,5\%$  (p) (d) (r).

$$u_{j \text{ meter lin}} = \frac{0,5}{\sqrt{3} \times 23} = 0,013 \text{ dB}$$

Power meter range change error (one change) =  $\pm 0,5\%$  (p) (d) (r).

$$u_{j \text{ range change error}} = \frac{0,5}{\sqrt{3} \times 23} = 0,013 \text{ dB}$$

$$u_{c \text{ test signal level}} = \sqrt{0,013^2 + 0,013^2} = 0,018 \text{ dB}$$

**Mismatch uncertainty when measuring the transmitter level and setting the level of the test signal source to -30 dB relative:**

- transmitter reflection coefficient is 0,5 (table F.1);
- power sensor reflection coefficient is 0,07 (d);
- attenuator reflection coefficients are 0,1 (d) (both attenuators);
- directional coupler reflection coefficients are 0,05 (d).

For the following mismatch calculations the directional coupler loss is assumed to be 0 dB (x1 linear). The isolating effect of the 10 dB attenuator is however taken into consideration (multiplication by 0,316 in linear terms).

Only the reflection coefficients of the transmitter, 10 dB attenuator, the directional coupler and the 20 dB attenuator are taken into account, the test signal source is ignored due to isolation. It is assumed that the spectrum analyser is connected during the power measurement with the same cable and the same attenuator setting as during the measurement. Therefore the mismatch uncertainties at this point cancel.

$$u_{j \text{ mismatch: power sensor and directional coupler}} = \frac{0,07 \times 0,05 \times 0,316^2 \times 100\%}{\sqrt{2}} = 0,025 \%(v)$$

$$u_{j \text{ mismatch: power sensor and 20 dB attenuator}} = \frac{0,07 \times 0,1 \times 0,316^2 \times 1^2 \times 100\%}{\sqrt{2}} = 0,049 \%(v)$$

$$u_{c \text{ mismatch: measuring test signal}} = \sqrt{2,475^2 + 0,495^2 + 0,025^2 + 0,049^2} = 2,525 \%(v)$$

**Mismatch uncertainty with the transmitter reconnected to the 10dB attenuator:**

Only the reflection coefficients of the transmitter, 10 dB attenuator, the directional coupler and the 20 dB attenuator are taken into account, the test signal source is ignored due to isolation:

- transmitter reflection coefficient is 0,5 (table F1);
- attenuator reflection coefficients are 0,1 (d);
- directional coupler reflection coefficients are 0,05 (d).

For the following mismatch calculations the directional coupler loss is assumed to be 0 dB (x1 linear). The isolating effect of the 10 dB attenuator is however taken into consideration (multiplication with 0,316 in linear terms).

$$u_{j \text{ mismatch: transmitter and 10dB attenuator}} = \frac{0,5 \times 0,1 \times 100\%}{\sqrt{2}} = 3,536 \%(v)$$

$$u_{j \text{ mismatch: transmitter and directional coupler}} = \frac{0,5 \times 0,05 \times 0,316^2 \times 100\%}{\sqrt{2}} = 0,177\%(v)$$

$$u_{j \text{ mismatch: transmitter and 20dB attenuator}} = \frac{0,5 \times 0,1 \times 0,316^2 \times 1^2 \times 100\%}{\sqrt{2}} = 0,353\%(v)$$

$$u_{c \text{ mismatch :test signal connected}} = \sqrt{3,536^2 + 0,177^2 + 0,353^2} = 3,558\%(v)$$

#### Combined mismatch uncertainties:

$$u_{c \text{ mismatch h}} = \frac{\sqrt{2,525^2 + 3,558^2}}{11,5} = 0,379dB$$

Combined uncertainty of the test signal:

$$u_{c \text{ test signal}} = \sqrt{0,018^2 + 0,379^2} = 0,379dB$$

Spectrum analyser log fidelity =  $\pm 1,5$  dB (d) (r):

$$u_{j \text{ log fidelity}} = \frac{1,5}{\sqrt{3}} = 0,866dB$$

One of the intermodulation products has a 2<sup>nd</sup> order dependency from the unwanted signal corresponding to 2 dB/dB, therefore the uncertainty of the level of the intermodulation product is doubled (see clause 6.5.5, and annex D clauses D.3.4.5.2 and D.5).

The combined standard uncertainty for intermodulation attenuation is:

$$u_{c \text{ intermodulation attenuation measurement}} = \sqrt{0,866^2 + (2 \times 0,379)^2} = 1,15dB$$

Using an expansion factor (coverage factor) of  $k = 1,96$ , the expanded measurement uncertainty is  $\pm 1,96 \times 1,15$  dB =  $\pm 2,25$  dB (see annex D, clause D.5.6.2 in part 2).

## 7.1.6 Attack time

### 7.1.6.1 Frequency behaviour (attack)

#### a) Methodology

Frequency behaviour (attack) is the time elapsed between switching on the transmitter and the moment when the carrier frequency is within defined limits. Transmitter output frequency variation as a function of time during this period is measured by means of a test discriminator providing vertical deflection to a storage oscilloscope (see figure 50).

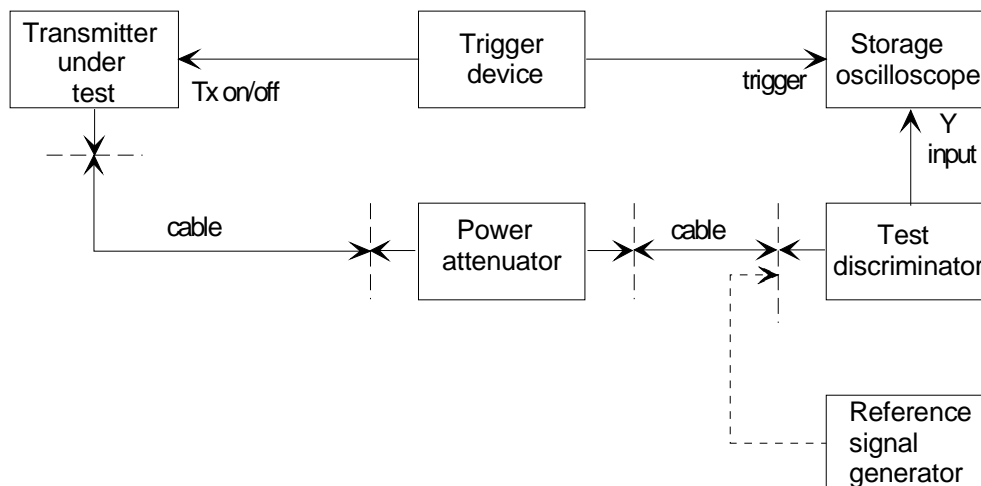

**Figure 50: Transmitter frequency/time measurement configuration (attack and release)**

With the oscilloscope time base set to 'repetitive' at an appropriate sweep rate, the oscilloscope display graticule is calibrated by means of the signal generator, to provide vertical reference points corresponding to the specification frequency limits or mask e.g.  $\pm$  one channel. The oscilloscope is then set to "single sweep" in preparation for the measurement.

When the trigger device is operated, it initiates the oscilloscope sweep and simultaneously switches on the transmitter. Any variation in transmitter output frequency will appear at the discriminator output as a varying DC voltage which will be recorded on the oscilloscope display as a plot of frequency against time.

**b) Measurement uncertainty:**

- signal generator frequency uncertainty is  $\pm 10$  Hz (d) (r);
- calibration uncertainty of discriminator (including the storage oscilloscope) is  $\pm 100$  Hz (r);
- DC drift of discriminator is equivalent to  $\pm 100$  Hz (d) (r).

Combined standard uncertainty of the frequency measurement:

$$u_{j \text{ frequency measurement}} = \sqrt{\frac{((100 \text{ Hz})^2 + (100 \text{ Hz})^2 + (10 \text{ Hz})^2)}{3}} = 81,9 \text{ Hz}$$

Frequency uncertainty is converted to time uncertainty by means of formula 5.2 and table F.1. Dependency values found in table F.1 are:

- mean value of 1,0 ms/kHz;
- standard deviation of 0,3 ms/kHz.

Therefore:

$$u_{j \text{ time}} = \sqrt{(0,0819 \text{ kHz})^2 \times ((1,0 \text{ ms/kHz})^2 + (0,3 \text{ ms/kHz})^2)} = 0,086 \text{ ms}$$

Random uncertainty is 0,5 ms (m) (c) ( $\sigma$ ).

Oscilloscope timing uncertainty is  $\pm 1,0$  ms (d) (r).

Trigger moment uncertainty is  $\pm 1,0$  ms (d) (r).

The combined standard uncertainty:

$$u_{c \text{ frequency behaviour}} = \sqrt{(0,086 \text{ ms})^2 + (0,5 \text{ ms})^2 + \left(\frac{(1 \text{ ms})^2 + (1 \text{ ms})^2}{3}\right)} = 0,961 \text{ ms}$$

Using an expansion factor (coverage factor) of  $k = 1,96$ , the expanded measurement uncertainty is  $\pm 1,96 \times 0,961 \text{ ms} = \pm 1,9 \text{ ms}$  (see annex D, clause D.5.6.2 in part 2).

### 7.1.6.2 Power behaviour (attack)

#### a) Methodology

Power behaviour (attack) is the time elapsed between switching on the transmitter and the moment when the transmitter output power level is within defined limits i.e. a percentage of full power. Transmitter output power variation as a function of time during this period is measured on a spectrum analyser set to zero span mode (see figure 51).

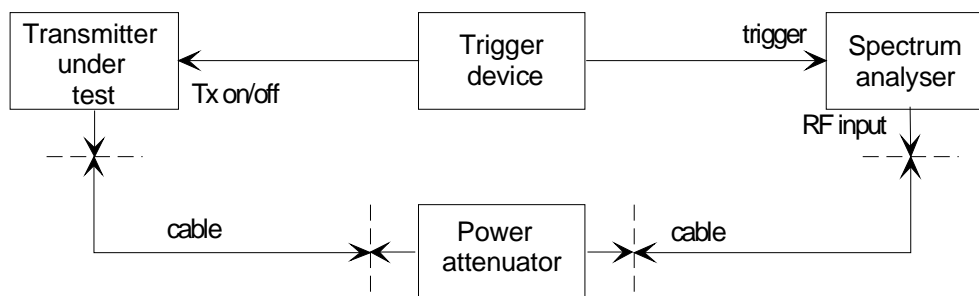

**Figure 51: Transmitter power level/time measurement configuration (attack and release)**

With the spectrum analyser time base set to "repetitive" at an appropriate sweep rate, the transmitter is switched on and the analyser sensitivity adjusted until the measured signal coincides with the reference level. The analyser is then set to "single shot", and the transmitter switched off in preparation for the measurement.

When the trigger device is operated, this simultaneously initiates the spectrum analyser sweep and switches on the transmitter. Any variation in transmitter output power level will be recorded on the spectrum analyser display as a plot of output power level against time.

#### b) Measurement uncertainty:

Spectrum analyser log fidelity  $\pm 0,4 \text{ dB}$  (d) (r).

$$u_{j \log \text{ fidelity}} = \frac{0,4}{\sqrt{3}} = 0,231 \text{ dB}$$

The power level difference uncertainty is then converted to time uncertainty by means of formula 5.2 and table F.1. Dependency values found in table F.1 are:

- mean value of 0,3 ms/%;
- standard deviation of 0,1 ms/%.

Therefore:

$$u_{j \text{ time}} = \sqrt{(0,231 \times 11,5)^2 \times ((0,3 \text{ ms} / \%)^2 + (0,1 \text{ ms} / \%)^2)} = 0,840 \text{ ms}$$

Random uncertainty is 0,5 ms (m) (c) ( $\sigma$ ).

Oscilloscope timing uncertainty is  $\pm 1,0 \text{ ms}$  (d) (r).

Trigger moment uncertainty is  $\pm 1,0 \text{ ms}$  (d) (r).

The combined standard uncertainty:

$$u_{c \text{ frequency behaviour}} = \sqrt{(0,840 \text{ ms})^2 + (0,5 \text{ ms})^2 + \left( \frac{(1 \text{ ms})^2 + (1 \text{ ms})^2}{3} \right)} = 1,274 \text{ ms}$$



Using an expansion factor (coverage factor) of  $k = 1,96$ , the expanded measurement uncertainty is  $\pm 1,96 \times 1,274 \text{ ms} = \pm 2,5 \text{ ms}$  (see annex D, clause D.5.6.2 in part 2).

## 7.1.7 Release time

### 7.1.7.1 Frequency behaviour (release)

The only difference between this measurement and the measurement for attack in clause 7.1.6.1 is that in this case the measurement is to determine the time elapsed between switching off the transmitter and the moment when the carrier frequency falls outside defined limits. Measurement uncertainty for release is therefore the same as for attack.

### 7.1.7.2 Power behaviour (release)

The only difference between this measurement and the measurement for attack in clause 7.1.6.2 is that in this case the measurement is to determine the time elapsed between switching off the transmitter and the moment when the carrier power is within defined limits. Measurement uncertainty for release is therefore the same as for attack.

## 7.1.8 Transient behaviour of the transmitter

Transient behaviour of the transmitter is the period of transient frequency/power behaviour immediately following the switching on or off of the transmitter.

### 7.1.8.1 Transient frequency behaviour

#### a) Methodology

Transient frequency behaviour is the frequency error of the transmitter during switch on and switch off transients. Transmitter frequency error as a function of time during this period is measured by means of a test discriminator providing vertical deflection to a storage oscilloscope (see figure 52a).

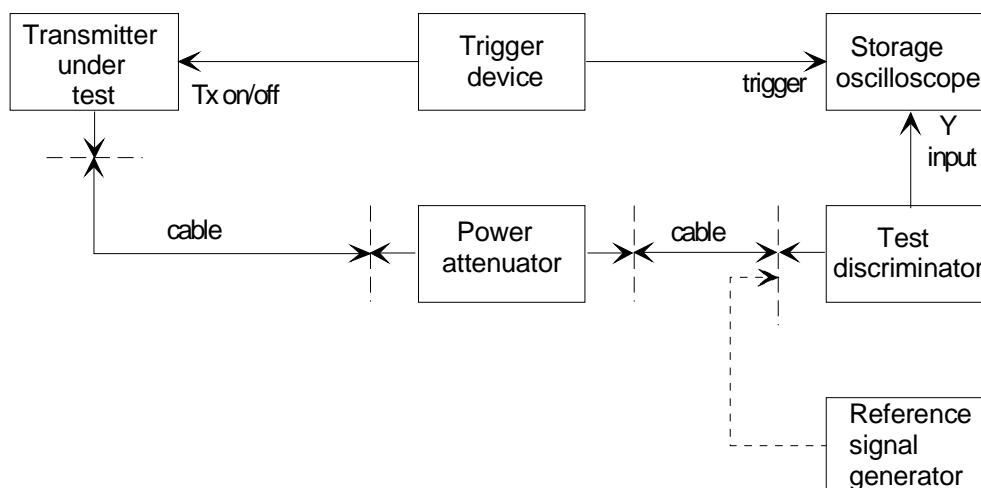

**Figure 52a: Transmitter frequency/time measurement configuration (attack and release)**

With the transmitter switched off, the oscilloscope time base is set to 'repetitive' at an appropriate sweep rate. The oscilloscope display graticule is then calibrated by means of the signal generator, to provide vertical reference points corresponding to the specification frequency limits or mask e.g.  $\pm$  one channel. When this has been accomplished, the trigger selector is set to 'single sweep' and the transmitter set to on or off depending upon which transient condition is to be measured.

When the trigger device is operated, this simultaneously initiates the oscilloscope sweep and switches the transmitter on or off according to the measurement. Any variation in transmitter output frequency will appear at the discriminator output as a varying DC voltage which will be recorded on the oscilloscope display as a plot of frequency against time.

**b) Measurement uncertainty:**

- signal generator frequency uncertainty is  $\pm 10$  Hz (d) (r);
- calibration uncertainty of discriminator (including the storage oscilloscope) is  $\pm 100$  Hz (d) (r);
- DC drift of discriminator is equivalent to  $\pm 100$  Hz (d) (r).

The combined standard uncertainty of the frequency measurement:

$$u_{c \text{ frequency measurement}} = \sqrt{\frac{((100 \text{ Hz})^2 + (100 \text{ Hz})^2 + (10 \text{ Hz})^2)}{3}} = 81,9 \text{ Hz}$$

Using an expansion factor (coverage factor) of  $k = 1,96$ , the expanded measurement uncertainty is  $\pm 1,96 \times 81,9 \text{ Hz} = \pm 161 \text{ Hz}$  (see annex D, clause D.5.6.2 in part 2).

**7.1.8.2 Power level slope****a) Methodology**

Transmitter power output as a function of time (power level slope) is measured during switch on and switch off transients by means of a spectrum analyser set to zero span mode (see figure 52b).

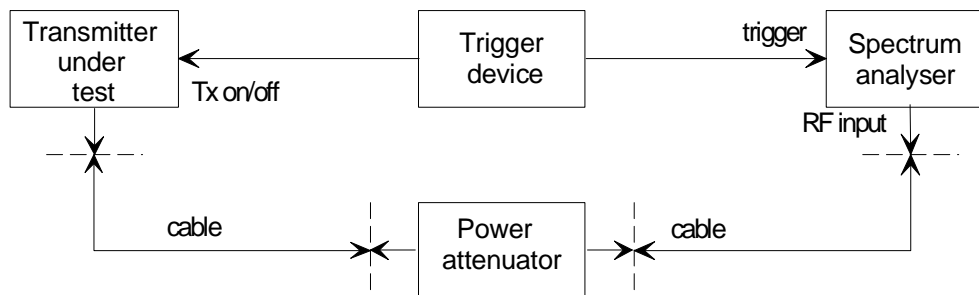

**Figure 52b: Transmitter power level/time measurement configuration (attack and release)**

With the transmitter switched on, and the spectrum analyser in zero span mode, the analyser sensitivity is adjusted until the transmitter signal displayed on the screen coincides with the reference level. The trigger selector is then set to "single shot", and the trigger device actuated to obtain a display of power level slope. The sweep is finally adjusted so as to position the -6 dB point and the -30 dB points at left and right extremes of the display graticule, then the transmitter switched on or off depending upon which transient condition is to be measured.

When the trigger device is operated, this simultaneously initiates the spectrum analyser sweep and switches the transmitter on or off according to the measurement. Any variation in transmitter output power level will be recorded on the spectrum analyser display as a plot of output power level against time.

**b) Measurement uncertainty:**

(The following calculations are based on the assumption that the power level versus time is linear in logarithmic terms.)

Spectrum analyser log fidelity at -6 dB is  $\pm 0,6$  dB (d) (r).

$$\text{This is converted to time uncertainty: } \pm(0,6/(-6 + 30) \times 100) \% = \pm 2,5 \%$$

Spectrum analyser log fidelity at -30 dB is  $\pm 1,5$  dB (d) (r).

$$\text{This is converted to time uncertainty: } \pm(1,5/(-6 + 30) \times 100) \% = \pm 6,25 \%$$

Time measurement uncertainty (counts twice) is  $\pm 2$  % of full screen  $\pm 2$  % (d) (r).

Random uncertainty 1 % (m) ( $\sigma$ ).

The combined standard uncertainty is:

$$u_{c \text{ power level slope}} = \sqrt{\frac{2,5\%^2 + 6,25\%^2 + 2,0\%^2 + 2,0\%^2}{3} + 1,0\%^2} = 4,33 \%$$

Using an expansion factor (coverage factor) of  $k = 1,96$ , the expanded measurement uncertainty is  $\pm 1,96 \times 4,33 \% = \pm 8,5 \%$  (see annex D, clause D.5.6.2 in part 2).

## 7.1.9 Frequency deviation

### 7.1.9.1 Maximum permissible frequency deviation

#### a) Methodology

The AF signal from the audio frequency oscillator is applied to the modulation input of the transmitter under test at a level 20 dB above the level of normal test modulation (see figure 53).

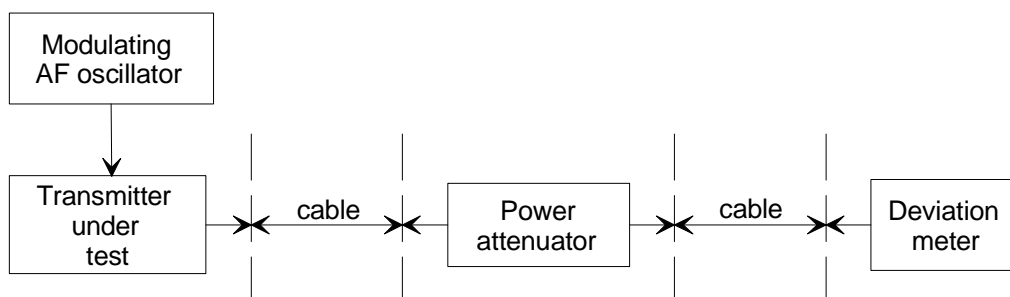

**Figure 53: Maximum permissible frequency deviation measurement configuration**

The RF output from the transmitter under test is applied to a deviation meter through a power attenuator. The maximum deviation is measured as 4,0 kHz.

#### b) Measurement uncertainty

As the modulating signal level is 20 dB above that required for normal test modulation, it is assumed that the AF level uncertainty of the modulating AF oscillator has no influence.

Deviation uncertainty is  $\pm 1 \% \pm 1$  digit (f) (d) (r).

$\pm 1$  digit is 10 Hz which is calculated as  $(10/4000) \times 100 \% = \pm 0,25 \%$ .

Residual modulation is  $\pm 20$  Hz (f) (d) (r) which is converted to a percentage of the measured deviation (4 kHz):  $(20/4000) \times 100 \% = \pm 0,5 \%$

NOTE: The random contribution is deemed to be negligible and has therefore been ignored.

The combined standard uncertainty for maximum permissible frequency deviation is:

$$u_{j \text{ total}} = \sqrt{\frac{(1,0\%)^2 + (0,25\%)^2 + (0,5\%)^2}{3}} = 0,66 \%$$

Using an expansion factor (coverage factor) of  $k = 1,96$ , the expanded measurement uncertainty is  $\pm 1,96 \times 0,66 \% = \pm 1,3 \%$  (see annex D, clause D.5.6.2 in part 2).

#### c) Spreadsheet implementation of measurement uncertainty

This calculation has been implemented in a corresponding spreadsheet (see file "Maximum permissible frequency deviation.xls") and is available in tr\_10002801v010301p0.zip.

### 7.1.9.2 Response of the transmitter to modulation frequencies above 3 kHz

#### a) Methodology

The AF signal from the audio frequency oscillator is applied to the modulation input of the transmitter under test at the specified level (see figure 54).

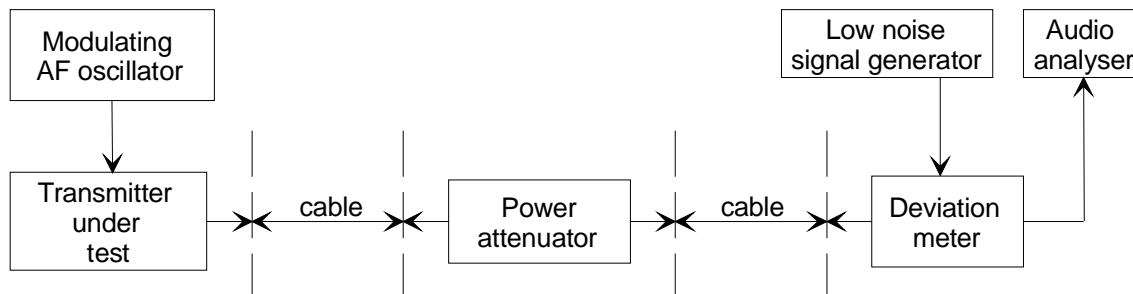

**Figure 54: Measurement configuration for modulation frequencies above 3 kHz**

The RF output from the transmitter under test is applied to a deviation meter through a power attenuator. The demodulated signal is then applied to the audio analyser. A low noise signal generator is used as the local oscillator for the deviation meter for demodulating signals with modulation frequencies above 3 kHz, to improve the noise behaviour. The result is corrected for AF gain and AF filter shaping. It is assumed that the measurement is conducted sufficiently above the measuring system noise level.

#### b) Measurement uncertainty:

(As a low noise signal generator is used for the deviation meter local oscillator, it is assumed that residual deviation is insignificant and has no influence on the measurement).

AF oscillator level uncertainty =  $\pm 0,70\%$  (v) (d) (r).

Deviation meter demodulator uncertainty =  $\pm 1,0\%$  (v) (d) (r).

Deviation meter AF gain uncertainty =  $\pm 2,0\%$  (v) (d) (r).

Audio analyser AC voltmeter uncertainty =  $\pm 4,0\%$  (v) (d) (r).

The combined standard uncertainty is then calculated:

$$u_j = \sqrt{\frac{(0,70\%)^2 + (1,0\%)^2 + (4,0\%)^2 + (2,0\%)^2}{3}} = 2,68\%$$

The combined standard uncertainty is converted to dB:  $2,68\% / 11,5 = 0,233$  dB.

Using an expansion factor (coverage factor) of  $k = 1,96$ , the expanded measurement uncertainty is  $\pm 1,96 \times 0,233$  dB =  $\pm 0,46$  dB (see annex D, clause D.5.6.2 in part 2).

#### c) Spreadsheet implementation of measurement uncertainty

This calculation has been implemented in a corresponding spreadsheet (see file "Response to mod freqs above 3kHz.xls") and is available in tr\_10002801v010301p0.zip.

## 7.2 Radiated tests

### 7.2.1 Frequency error (30 MHz to 1 000 MHz)

#### 7.2.1.1 Anechoic Chamber

The method of calculating the expanded uncertainty for tests in which signal levels in dB are involved is equally adopted for the frequency error test in which all the uncertainties are in the units of Hz. That is, all the uncertainty contributions are converted into standard uncertainties and combined by the RSS method under the assumption that they are all stochastic. All the uncertainty components which contribute to the test are listed in table 49. Annex A should be consulted for the sources and/or magnitudes of the uncertainty contributions.

##### 7.2.1.1.1 Contributions from the measurement

**Table 49: Contributions from the measurement**

<b>u<sub>j</sub> or i</b>	<b>Description of uncertainty contributions</b>	<b>Hz</b>
u <sub>i01</sub>	random uncertainty	
u <sub>j56</sub>	frequency counter: absolute reading	
u <sub>j05</sub>	mutual coupling: detuning effect of the absorbing material on the EUT	
u <sub>j09</sub>	mutual coupling: detuning effect of the test antenna on the EUT	

The standard uncertainties from table 49 should be combined by RSS in accordance with ETR 273 [12], part 1, subpart 1, clause 5. The combined standard uncertainty of the frequency measurement (*u<sub>c</sub> contributions from the measurement*) is the combination of the components outlined above.

$$u_c = u_{c \text{ contributions from the measurement}} = \text{---,--- Hz}$$

##### 7.2.1.1.2 Expanded uncertainty

Using an expansion factor (coverage factor) of  $k = 1,96$ , the expanded measurement uncertainty is  $\pm 1,96 \times u_c = \pm \text{---,--- Hz}$  (see annex D, clause D.5.6.2 in part 2).

#### 7.2.1.2 Anechoic Chamber with a ground plane

The method of calculating the expanded uncertainty for tests in which signal levels in dB are involved is equally adopted for the frequency error test in which all the uncertainties are in the units of Hz. That is, all the uncertainty contributions are converted into standard uncertainties and combined by the RSS method under the assumption that they are all stochastic. All the uncertainty components which contribute to the test are listed in table 50. Annex A should be consulted for the sources and/or magnitudes of the uncertainty contributions.

##### 7.2.1.2.1 Contributions from the measurement

**Table 50: Contributions from the measurement**

<b>u<sub>j</sub> or i</b>	<b>Description of uncertainty contributions</b>	<b>Hz</b>
u <sub>i01</sub>	random uncertainty	
u <sub>j56</sub>	frequency counter: absolute reading	
u <sub>j05</sub>	mutual coupling: detuning effect of the absorbing material on the EUT	
u <sub>j09</sub>	mutual coupling: detuning effect of the test antenna on the EUT	

### 7.2.1.2.2 Expanded uncertainty

The standard uncertainties from table 50 should be combined by RSS in accordance with ETR 273 [12], part 1, subpart 1, clause 5. The combined standard uncertainty of the frequency measurement ( $u_c$  contributions from the measurement) is the combination of the components outlined above.

$$u_c = u_c \text{ contributions from the measurement} = \text{---,--- Hz}$$

Using an expansion factor (coverage factor) of  $k = 1,96$ , the expanded measurement uncertainty is  $\pm 1,96 \times u_c = \pm \text{---,--- Hz}$  (see annex D, clause D.5.6.2 in part 2).

### 7.2.1.3 Open Area Test Site

The method of calculating the expanded uncertainty for tests in which signal levels in dB are involved is equally adopted for the frequency error test in which all the uncertainties are in the units of Hz. That is, all the uncertainty contributions are converted into standard uncertainties and combined by the RSS method under the assumption that they are all stochastic. All the uncertainty components which contribute to the test are listed in table 51. Annex A should be consulted for the sources and/or magnitudes of the uncertainty contributions.

#### 7.2.1.3.1 Contributions from the measurement

**Table 51: Contributions from the measurement**

$u_j$ or $i$	Description of uncertainty contributions	Hz
$u_{i01}$	random uncertainty	
$u_{j09}$	mutual coupling: detuning effect of the test antenna on the EUT	
$u_{j56}$	frequency counter: absolute reading	

#### 7.2.1.3.2 Expanded uncertainty

The standard uncertainties from table 51 should be combined by RSS in accordance with ETR 273 [12], part 1, subpart 1, clause 5. The combined standard uncertainty of the frequency measurement ( $u_c$  contributions from the measurement) is the combination of the components outlined above.

$$u_c = u_c \text{ contributions from the measurement} = \text{---,--- Hz}$$

Using an expansion factor (coverage factor) of  $k = 1,96$ , the expanded measurement uncertainty is  $\pm 1,96 \times u_c = \pm \text{---,--- Hz}$  (see annex D, clause D.5.6.2 in part 2).

#### 7.2.1.4 Stripline

This test is not usually performed in a Stripline and is therefore not considered here.

#### 7.2.1.5 Test fixture

The method of calculating the expanded uncertainty for tests in which signal levels in dB are involved is equally adopted for the frequency error test in which all the uncertainties are in the units of Hz. That is, all the uncertainty contributions are converted into standard uncertainties and combined by the RSS method under the assumption that they are all stochastic. All the uncertainty components which contribute to the test are listed in table 52. Annex A should be consulted for the sources and/or magnitudes of the uncertainty contributions.

### 7.2.1.5.1 Contributions from the measurement

**Table 52: Contributions from the measurement**

$u_j$ or $i$	Description of uncertainty contributions	Hz
$u_{i01}$	random uncertainty	
$u_{j56}$	frequency counter: absolute reading	
$u_{j60}$	Test Fixture: effect on the EUT	
$u_{j61}$	Test Fixture: climatic facility effect on the EUT	

The standard uncertainties from table 52 should be combined by RSS in accordance with ETR 273 [12], part 1, subpart 1, clause 5. The combined standard uncertainty of the frequency measurement ( $u_c$  contributions from the measurement) is the combination of the components outlined above.

$$u_c = u_{c \text{ contributions from the measurement}} = \dots \text{ Hz}$$

### 7.2.1.5.2 Expanded uncertainty

Using an expansion factor (coverage factor) of  $k = 1,96$ , the expanded measurement uncertainty is  $\pm 1,96 \times u_c = \pm \dots \text{ Hz}$  (see annex D, clause D.5.6.2 in part 2).

## 7.2.2 Effective radiated power (30 MHz to 1 000 MHz)

A fully worked example illustrating the methodology to be used can be found in ETR 273 [12], part 1, subpart 2, clause 4.

### 7.2.2.1 Anechoic Chamber

#### 7.2.2.1.1 Uncertainty contributions: Stage one: EUT measurement

For the measurement of effective radiated power two stages of test are involved. The first stage (the EUT measurement) is to measure on the receiving device, a level from the EUT as shown in figure 55 (shaded components are common to both stages of the test).

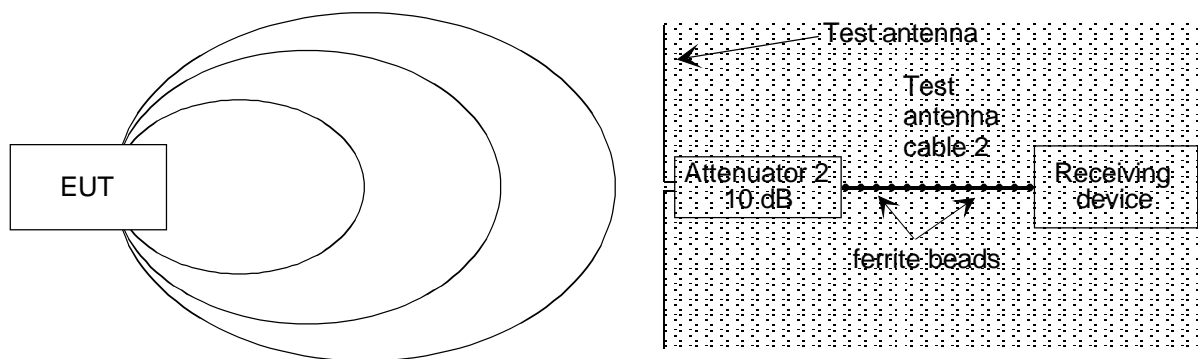

**Figure 55: Stage one: EUT measurement**

Due to the commonality of all of the components from the test antenna to the receiver in both stages of the test, the mismatch uncertainty contributes identically in each stage and hence cancels. Similarly, the systematic uncertainty contributions (e.g. test antenna cable loss, etc.) of the individual components also cancel.

The magnitude of the random uncertainty contribution to each stage of the procedure can be assessed from multiple repetition of the EUT measurement. All the uncertainty components which contribute to this stage of the test are listed in table 53. Annex A should be consulted for the sources and/or magnitudes of the uncertainty contributions.

Table 53: Contributions from the EUT measurement

$u_j$ or $i$	Description of uncertainty contributions	dB
$u_{j37}$	mismatch: receiving part	
$u_{j19}$	cable factor: test antenna cable	
$u_{j41}$	insertion loss: test antenna cable	0,00
$u_{j40}$	insertion loss: test antenna attenuator	0,00
$u_{j47}$	receiving device: absolute level	
$u_{j53}$	EUT: influence of setting the power supply on the ERP of the carrier	
$u_{j20}$	position of the phase centre: within the EUT volume	
$u_{j21}$	positioning of the phase centre: within the EUT over the axis of rotation of the turntable	
$u_{j50}$	EUT: influence of the ambient temperature on the ERP of the carrier	
$u_{j16}$	range length	0,00
$u_{j01}$	reflectivity of absorbing material: EUT to the test antenna	0,00
$u_{j45}$	antenna: gain of the test antenna	0,00
$u_{j46}$	antenna: tuning of the test antenna	0,00
$u_{j55}$	EUT: mutual coupling to the power leads	
$u_{j08}$	mutual coupling: amplitude effect of the test antenna on the EUT	
$u_{j04}$	mutual coupling: EUT to its images in the absorbing material	
$u_{j06}$	mutual coupling: test antenna to its images in the absorbing material	
$u_{i01}$	random uncertainty	

The standard uncertainties from table 53 should be combined by RSS in accordance with ETR 273 [12], part 1, subpart 1, clause 5. This gives the combined standard uncertainty ( $u_c$  contribution from the EUT measurement) for the EUT measurement in dB.

#### 7.2.2.1.2 Uncertainty contributions: Stage two: Substitution

The second stage (the substitution) involves replacing the EUT with a substitution antenna and signal source as shown in figure 56 and adjusting the output level of the signal generator until the same level as in stage one is achieved on the receiving device.

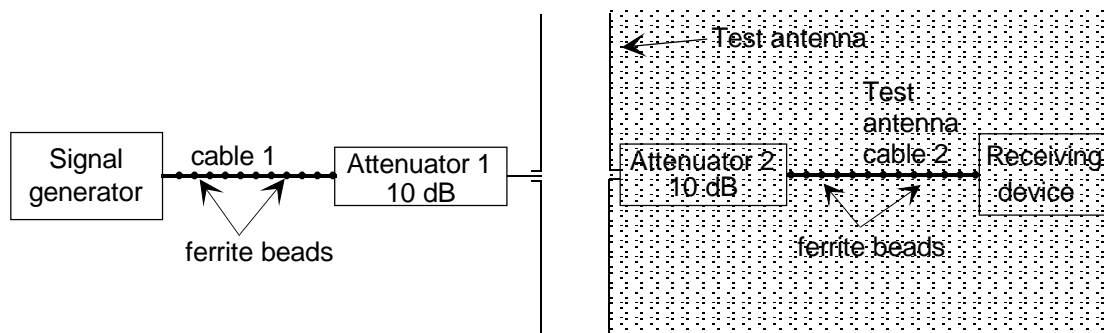

Figure 56: Stage two: Substitution measurement

All the uncertainty components which contribute to this stage of the test are listed in table 54. Annex A should be consulted for the sources and/or magnitudes of the uncertainty contributions.



Table 54: Contributions from the substitution

u <sub>j</sub> or i	Description of uncertainty contributions	dB
u <sub>j36</sub>	mismatch: transmitting part	
u <sub>j37</sub>	mismatch: receiving part	
u <sub>j38</sub>	signal generator: absolute output level	
u <sub>j39</sub>	signal generator: output level stability	
u <sub>j19</sub>	cable factor: substitution antenna cable	
u <sub>j19</sub>	cable factor: test antenna cable	
u <sub>j41</sub>	insertion loss: substitution antenna cable	
u <sub>j41</sub>	insertion loss: test antenna cable	0,00
u <sub>j40</sub>	insertion loss: substitution antenna attenuator	
u <sub>j40</sub>	insertion loss: test antenna attenuator	0,00
u <sub>j47</sub>	receiving device: absolute level	0,00
u <sub>j16</sub>	range length	0,00
u <sub>j02</sub>	reflectivity of absorbing material: substitution antenna to the test antenna	0,00
u <sub>j45</sub>	antenna: gain of the substitution antenna	0,50
u <sub>j45</sub>	antenna: gain of the test antenna	0,00
u <sub>j46</sub>	antenna: tuning of the test antenna	0,00
u <sub>j22</sub>	position of the phase centre: substitution antenna	
u <sub>j06</sub>	mutual coupling: substitution antenna to its images in the absorbing material	
u <sub>j06</sub>	mutual coupling: test antenna to its images in the absorbing material	0,50
u <sub>j11</sub>	mutual coupling: substitution antenna to the test antenna	0,00
u <sub>j12</sub>	mutual coupling: interpolation of mutual coupling and mismatch loss correction factors	0,00
u <sub>i01</sub>	random uncertainty	

The standard uncertainties from table 54 should be combined by RSS in accordance with ETR 273 [12], part 1, subpart 1, clause 5. This gives the combined standard uncertainty ( $u_c$  contributions from the substitution) for the substitution measurement in dB.

### 7.2.2.1.3 Expanded uncertainty

The combined standard uncertainty of the effective radiated power measurement is the RSS combination of the components outlined in clauses 7.2.2.1.1 and 7.2.2.1.2. The components to be combined are  $u_c$  contribution from the EUT measurement and  $u_c$  contribution from the substitution:

$$u_c = \sqrt{u_{c \text{ contribution from the EUT measurement}}^2 + u_{c \text{ contribution from the substitution}}^2} = \_, \_ \text{ dB}$$

Using an expansion factor (coverage factor) of  $k = 1,96$ , the expanded measurement uncertainty is  $\pm 1,96 \times u_c = \pm \_, \_ \text{ dB}$  (see annex D, clause D.5.6.2 in part 2).

## 7.2.2.2 Anechoic Chamber with a ground plane

### 7.2.2.2.1 Uncertainty contributions: Stage one: EUT measurement

For the measurement of effective radiated power two stages of test are involved. The first stage (the EUT measurement) is to measure on the receiving device, a level from the EUT as shown in figure 57 (shaded components are common to both stages of the test).

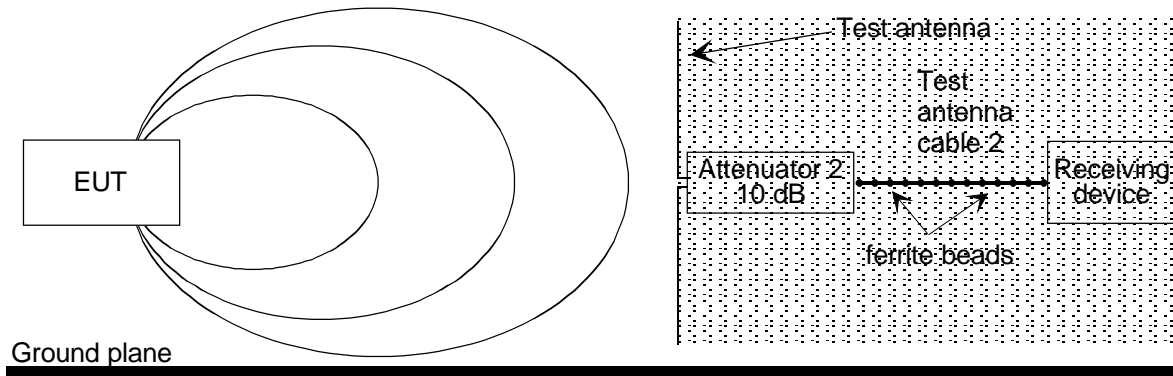

**Figure 57: Stage one: EUT measurement**

Due to the commonality of all of the components from the test antenna to the receiver in both stages of the test, the mismatch uncertainty contributes identically to both stages and hence cancels. Similarly, the systematic uncertainty contributions (e.g. test antenna cable loss, etc.) of the individual components also cancel.

The magnitude of the random uncertainty contribution to this stage of the procedure can be assessed from multiple repetition of the EUT measurement. All the uncertainty components which contribute to this stage of the test are listed in table 55. Annex A should be consulted for the sources and/or magnitudes of the uncertainty contributions.

**Table 55: Contributions from the EUT measurement**

$u_j$ or $i$	Description of uncertainty contributions	dB
$u_{j37}$	mismatch: receiving part	
$u_{j19}$	cable factor: test antenna cable	0,00
$u_{j41}$	insertion loss: test antenna cable	0,00
$u_{j40}$	insertion loss: test antenna attenuator	0,00
$u_{j47}$	receiving device: absolute level	0,00
$u_{j53}$	EUT: influence of setting the power supply on the ERP of the carrier	
$u_{j20}$	position of the phase centre: within the EUT volume	
$u_{j21}$	positioning of the phase centre: within the EUT over the axis of rotation of the turntable	
$u_{j50}$	EUT: influence of the ambient temperature on the ERP of the carrier	
$u_{j16}$	range length	
$u_{j01}$	reflectivity of absorbing material: EUT to the test antenna	
$u_{j45}$	antenna: gain of the test antenna	0,00
$u_{j46}$	antenna: tuning of the test antenna	0,00
$u_{j17}$	correction: off boresight angle in the elevation plane	0,00
$u_{j55}$	EUT: mutual coupling to the power leads	
$u_{j08}$	mutual coupling: amplitude effect of the test antenna on the EUT	
$u_{j04}$	mutual coupling: EUT to its images in the absorbing material	
$u_{j13}$	mutual coupling: EUT to its image in the ground plane	
$u_{j06}$	mutual coupling: test antenna to its images in the absorbing material	
$u_{j14}$	mutual coupling: test antenna to its image in the ground plane	
$u_{i01}$	random uncertainty	

The standard uncertainties from table 55 should be combined by RSS in accordance with ETR 273 [12], part 1, subpart 1, clause 5. This gives the combined standard uncertainty ( $u_c$  contribution from the EUT measurement) for the EUT measurement in dB.

### 7.2.2.2.2 Uncertainty contributions: Stage two: Substitution measurement

The second stage (the substitution) involves replacing the EUT with a substitution antenna and signal source as shown in figure 58 and adjusting the output level of the signal generator until the same level as in stage one is achieved on the receiving device.

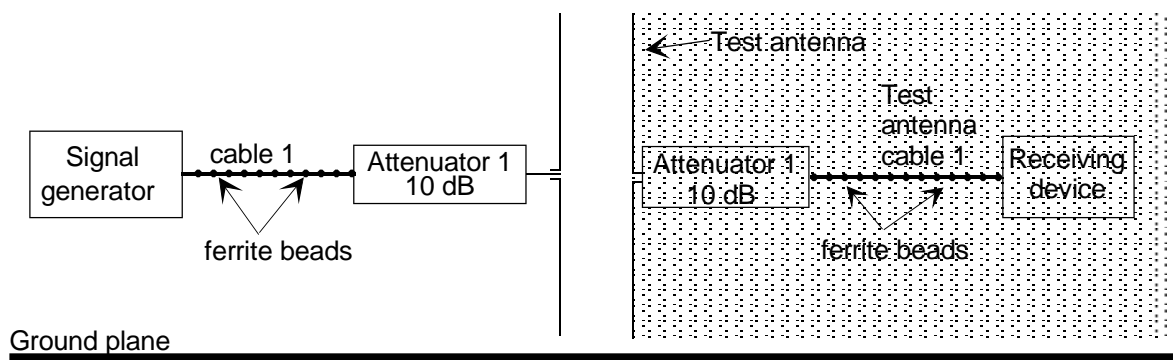

**Figure 58: Stage two: Substitution measurement**

All the uncertainty components which contribute to this stage of the test are listed in table 56. Annex A should be consulted for the sources and/or magnitudes of the uncertainty contributions.

**Table 56: Contributions from the substitution**

$u_j$ or $i$	Description of uncertainty contributions	dB
$u_{j36}$	mismatch: transmitting part	
$u_{j37}$	mismatch: receiving part	
$u_{j38}$	signal generator: absolute output level	
$u_{j39}$	signal generator: output level stability	
$u_{j19}$	cable factor: substitution antenna cable	
$u_{j19}$	cable factor: test antenna cable	
$u_{j41}$	insertion loss: substitution antenna cable	
$u_{j41}$	insertion loss: test antenna cable	0,00
$u_{j40}$	insertion loss: substitution antenna attenuator	
$u_{j40}$	insertion loss: test antenna attenuator	0,00
$u_{j47}$	receiving device: absolute level	0,00
$u_{j16}$	range length	0,00
$u_{j18}$	correction: measurement distance	
$u_{j02}$	reflectivity of absorbing material: substitution antenna to the test antenna	
$u_{j45}$	antenna: gain of substitution antenna	
$u_{j45}$	antenna: gain of the test antenna	0,00
$u_{j46}$	antenna: tuning of the substitution antenna	
$u_{j46}$	antenna: tuning of the test antenna	0,00
$u_{j22}$	position of the phase centre: substitution antenna	
$u_{j17}$	correction: off boresight angle in the elevation plane	
$u_{j06}$	mutual coupling: substitution antenna to its images in the absorbing material	
$u_{j06}$	mutual coupling: test antenna to its images in the absorbing material	
$u_{j14}$	mutual coupling: substitution antenna to its image in the ground plane	
$u_{j14}$	mutual coupling: test antenna to its image in the ground plane	
$u_{j11}$	mutual coupling: substitution antenna to the test antenna	
$u_{j12}$	mutual coupling: interpolation of mutual coupling and mismatch loss correction factors	
$u_{i01}$	random uncertainty	

The standard uncertainties from table 56 should be combined by RSS in accordance with ETR 273 [12], part 1, subpart 1, clause 5. This gives the combined standard uncertainty ( $u_c$  contributions from the substitution) for the substitution measurement in dB.

### 7.2.2.2.3 Expanded uncertainty

The combined standard uncertainty of the effective radiated power measurement is the RSS combination of the components outlined in 7.2.4.1 and 7.2.4.2. The components to be combined are  $u_c$  contribution from the EUT measurement and  $u_c$  contribution from the substitution:

$$u_c = \sqrt{u_{c\text{contribution from the EUT measurement}}^2 + u_{c\text{contribution from the substitution}}^2} = \_, \_ \text{ dB}$$

Using an expansion factor (coverage factor) of  $k = 1,96$ , the expanded measurement uncertainty is  $\pm 1,96 \times u_c = \pm \_, \_ \text{ dB}$  (see annex D, clause D.5.6.2 in part 2).

### 7.2.2.3 Open Area Test Site

#### 7.2.2.3.1 Uncertainty contributions: Stage one: EUT measurement

For the measurement of effective radiated power two stages of test are involved. The first stage (the EUT measurement) is to measure on the receiving device, a level from the EUT as shown in figure 59 (shaded components are common to both stages of the test).

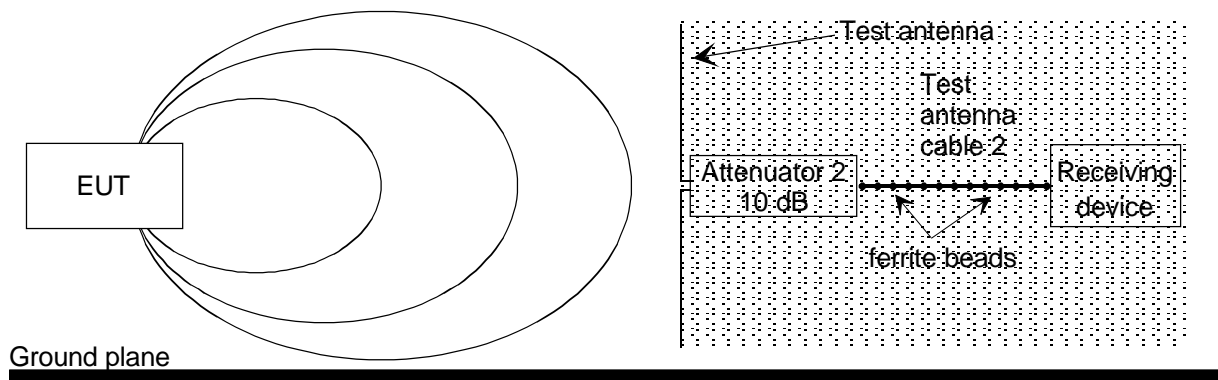

**Figure 59: Stage one: EUT measurement**

Due to the commonality of all of the components from the test antenna to the receiver in both stages of the test, the mismatch uncertainty contributes identically in each stage and hence cancels. Similarly, the systematic uncertainty contributions (e.g. test antenna cable loss, etc.) of the individual components also cancel.

The magnitude of the random uncertainty contribution to each stage of the procedure can be assessed from multiple repetition of the EUT measurements. All the uncertainty components which contribute to this stage of the test are listed in table 57. Annex A should be consulted for the sources and/or magnitudes of the uncertainty contributions.

Table 57: Contributions from the EUT measurement

$u_j$ or $i$	Description of uncertainty contributions	dB
$u_{j37}$	mismatch: receiving part	
$u_{j19}$	cable factor: test antenna cable	0,00
$u_{j41}$	insertion loss: test antenna cable	0,00
$u_{j40}$	insertion loss: test antenna attenuator	0,00
$u_{j47}$	receiving device: absolute level	0,00
$u_{j53}$	EUT: influence of setting the power supply on the ERP of the carrier	
$u_{j20}$	position of the phase centre: within the EUT volume	
$u_{j21}$	positioning of the phase centre: within the EUT over the axis of rotation of the turntable	
$u_{j50}$	EUT: influence of the ambient temperature on the ERP of the carrier	
$u_{j16}$	range length	
$u_{j45}$	antenna: gain of the test antenna	0,00
$u_{j46}$	antenna: tuning of the test antenna	0,00
$u_{j17}$	correction: off boresight angle in the elevation plane	0,00
$u_{j55}$	EUT: mutual coupling to the power leads	
$u_{j08}$	mutual coupling: amplitude effect of the test antenna on the EUT	
$u_{j13}$	mutual coupling: EUT to its image in the ground plane	
$u_{j14}$	mutual coupling: test antenna to its image in the ground plane	
$u_{i01}$	random uncertainty	

The standard uncertainties from table 57 should be combined by RSS in accordance with ETR 273 [12], part 1, subpart 1, clause 5. This gives the combined standard uncertainty ( $u_c$  contribution from the EUT measurement) for the EUT measurement in dB.

#### 7.2.2.3.2 Uncertainty contributions: Stage two: Substitution measurement

The second stage (the substitution) involves replacing the EUT with a substitution antenna and signal source as shown in figure 60 and adjusting the output level of the signal generator until the same level as in stage one is achieved on the receiving device.

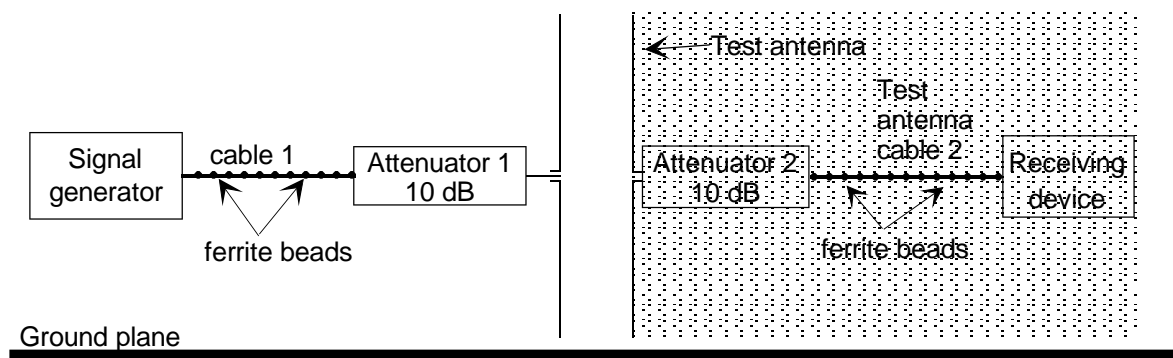

Figure 60: Stage two: Substitution

All the uncertainty components which contribute to this stage of the test are listed in table 58. Annex A should be consulted for the sources and/or magnitudes of the uncertainty contributions.

Table 58: Contributions from the substitution

$u_j$ or $i$	Description of uncertainty contributions	dB
$U_{j36}$	mismatch: transmitting part	
$U_{j37}$	mismatch: receiving part	
$U_{j38}$	signal generator: absolute output level	
$U_{j39}$	signal generator: output level stability	
$U_{j19}$	cable factor: substitution antenna cable	
$U_{j19}$	cable factor: test antenna cable	
$U_{j41}$	insertion loss: substitution antenna cable	
$U_{j41}$	insertion loss: test antenna cable	0,00
$U_{j40}$	insertion loss: substitution antenna attenuator	
$U_{j40}$	insertion loss: test antenna attenuator	0,00
$U_{j47}$	receiving device: absolute level	0,00
$U_{j16}$	range length	0,00
$U_{j18}$	correction: measurement distance	
$U_{j45}$	antenna: gain of the substitution antenna	
$U_{j45}$	antenna: gain of the test antenna	0,00
$U_{j46}$	antenna: tuning of the substitution antenna	
$U_{j46}$	antenna: tuning of the test antenna	0,00
$U_{j22}$	position of the phase centre: substitution antenna	
$U_{j17}$	correction: off boresight angle in the elevation plane	
$U_{j14}$	mutual coupling: substitution antenna to its image in the ground plane	
$U_{j14}$	mutual coupling: test antenna to its image in the ground plane	
$U_{j11}$	mutual coupling: substitution antenna to the test antenna	
$U_{j12}$	mutual coupling: interpolation of mutual coupling and mismatch loss correction factors	
$U_{i01}$	random uncertainty	

The standard uncertainties from table 58 should be combined by RSS in accordance with ETR 273 [12], part 1, subpart 1, clause 5. This gives the combined standard uncertainty ( $u_c$  contribution from the substitution) for the substitution measurement in dB.

### 7.2.2.3.3 Expanded uncertainty

The combined standard uncertainty of the effective radiated power measurement is the RSS combination of the components outlined in clauses 7.2.2.3.1 and 7.2.2.3.2. The components to be combined are  $u_c$  contribution from the EUT measurement and  $u_c$  contribution from the substitution:

$$u_c = \sqrt{u_{c \text{ contribution from the EUT measurement}}^2 + u_{c \text{ contribution from the substitution}}^2} = \dots, \dots \text{ dB}$$

Using an expansion factor (coverage factor) of  $k = 1,96$ , the expanded measurement uncertainty is  $\pm 1,96 \times u_c = \pm \dots, \dots$  dB (see annex D, clause D.5.6.2 in part 2).

### 7.2.2.4 Stripline

This test is not usually performed in a Stripline and is therefore not considered here.

### 7.2.2.5 Test fixture

The uncertainty contributions for the test are shown in table 59.

### 7.2.2.5.1 Contributions from the measurement

**Table 59: Contributions from the measurement**

$u_j$ or $i$	Description of uncertainty contributions	dB
$u_{j48}$	receiving device: linearity	
$u_{j50}$	EUT: influence of the ambient temperature on the ERP of the carrier	
$u_{j53}$	EUT: influence of setting the power supply on the ERP of the carrier	
$u_{j60}$	Test Fixture: climatic facility effect on the EUT	
$u_{j61}$	Test Fixture: effect on the EUT	
$u_{i01}$	random uncertainty	

The standard uncertainties from table 59 should be given values according to annex A. They should then be combined by the RSS (root sum of the squares) method in accordance with ETR 273 [12], part 1, subpart 1, clause 5. This gives the combined standard uncertainty ( $u_c$  contributions from the measurement) for the EUT measurement in dB.

### 7.2.2.5.2 Expanded uncertainty

Tests in a Test Fixture differ to radiated tests on all other types of site in that there is only one stage to the test. However, to calculate the measurement uncertainty, the Test Fixture measurement should be considered as stage two of a test in which stage one was on an accredited Free-Field Test Site. The combined standard uncertainty,  $u_c$ , of the effective radiated power measurement is therefore, simply the RSS combination of the value for  $u_c$  contributions from the measurement derived above and the combined uncertainty of the Free-field Test Site  $u_c$  contribution from the Free-Field Test Site.

$$u_c = \sqrt{u_{c \text{ contributions from the measurement}}^2 + u_{c \text{ contributions from the free-field test site}}^2} = \text{---, --- dB}$$

Using an expansion factor (coverage factor) of  $k = 1,96$ , the expanded measurement uncertainty is  $\pm 1,96 \times u_c = \pm \text{---, --- dB}$  (see annex D, clause D.5.6.2 in part 2).

## 7.2.3 Radiated spurious emissions

### 7.2.3.1 Anechoic Chamber

#### 7.2.3.1.1 Uncertainty contributions: Stage one: EUT measurement

For the measurement of spurious effective radiated power two stages of test are involved. The first stage (the EUT measurement) is to measure on the receiving device, a level from the EUT as shown in figure 61 (shaded components are common to both stages of the test).

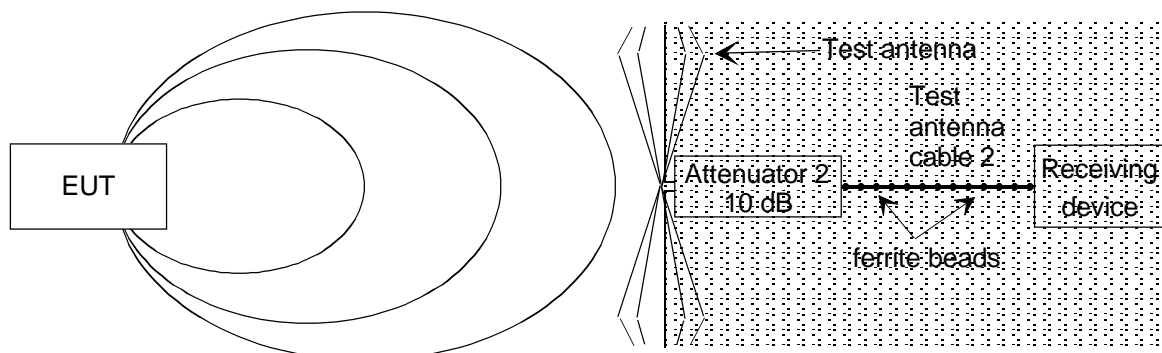

**Figure 61: Stage one: EUT measurement**

Due to the commonality of all of the components from the test antenna to the receiver in both stages of the test, the mismatch uncertainty contributes identically in each stage and hence cancels. Similarly, the systematic uncertainty contributions (e.g. test antenna cable loss, etc.) of the individual components also cancel.

The magnitude of the random uncertainty contribution to this stage of the procedure can be assessed from multiple repetition of the EUT measurement.

All the uncertainty components which contribute to this stage of the test are listed in table 60. Annex A should be consulted for the sources and/or magnitudes of the uncertainty contributions.

**Table 60: Contributions from the EUT measurement**

$u_j$ or $i$	Description of uncertainty contributions	dB
$u_{j37}$	mismatch: receiving part	0,00
$u_{j40}$	insertion loss: test antenna attenuator	0,00
$u_{j41}$	insertion loss: test antenna cable	0,00
$u_{j19}$	cable factor: test antenna cable	
$u_{j47}$	receiving device: absolute level	0,00
$u_{j54}$	EUT: influence of setting the power supply on the spurious emission level	0,03
$u_{j20}$	position of the phase centre: within the EUT volume	
$u_{j21}$	positioning of the phase centre: within the EUT over the axis of rotation of the turntable	
$u_{j51}$	EUT: influence of the ambient temperature on the spurious emission level	0,03
$u_{j16}$	range length	0,00
$u_{j01}$	reflectivity of absorbing material: EUT to the test antenna	0,00
$u_{j45}$	antenna: gain of the test antenna	0,00
$u_{j46}$	antenna: tuning of the test antenna	0,00
$u_{j55}$	EUT: mutual coupling to the power leads	
$u_{j08}$	mutual coupling: amplitude effect of the test antenna on the EUT	0,00
$u_{j04}$	mutual coupling: EUT to its images in the absorbing material	
$u_{j06}$	mutual coupling: test antenna to its images in the absorbing material	0,00
$u_{i01}$	random uncertainty	

The standard uncertainties from table 60 should be combined by RSS in accordance with ETR 273 [12], part 1, subpart 1, clause 5. This gives the combined standard uncertainty ( $u_c$  contribution from the EUT measurement) for the EUT measurement in dB.

#### 7.2.3.1.2 Uncertainty contributions: Stage two: Substitution

The second stage (the substitution) involves replacing the EUT with a substitution antenna and signal source as shown in figure 62 and adjusting the output level of the signal generator until the same level as in stage one is achieved on the receiving device.

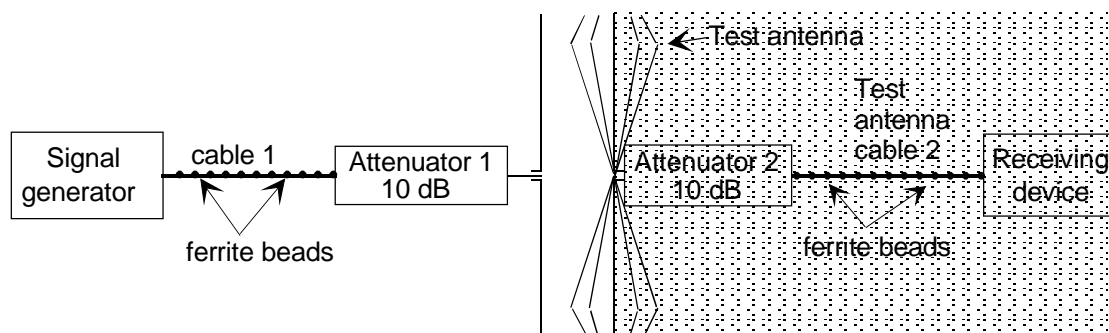

**Figure 62: Stage two: Substitution measurement**

All the uncertainty components which contribute to this stage of the test are listed in table 61. Annex A should be consulted for the sources and/or magnitudes of the uncertainty contributions.



Table 61: Contributions from the substitution

u <sub>j</sub> or i	Description of uncertainty contributions	dB
u <sub>j36</sub>	mismatch: transmitting part	
u <sub>j37</sub>	mismatch: receiving part	
u <sub>j38</sub>	signal generator: absolute output level	
u <sub>j39</sub>	signal generator: output level stability	
u <sub>j19</sub>	cable factor: substitution antenna cable	
u <sub>j19</sub>	cable factor: test antenna cable	
u <sub>j41</sub>	insertion loss: substitution antenna cable	
u <sub>j41</sub>	insertion loss: test antenna cable	0,00
u <sub>j40</sub>	insertion loss: substitution antenna attenuator	
u <sub>j40</sub>	insertion loss: test antenna attenuator	0,00
u <sub>j47</sub>	receiving device: absolute level	0,00
u <sub>j16</sub>	range length	0,00
u <sub>j02</sub>	reflectivity of absorbing material: substitution antenna to the test antenna	0,00
u <sub>j45</sub>	antenna: gain of the substitution antenna	
u <sub>j45</sub>	antenna: gain of the test antenna	0,00
u <sub>j46</sub>	antenna: tuning of the test antenna	0,00
u <sub>j22</sub>	position of the phase centre: substitution antenna	
u <sub>j06</sub>	mutual coupling: substitution antenna to its images in the absorbing material	
u <sub>j06</sub>	mutual coupling: test antenna to its images in the absorbing material	
u <sub>j11</sub>	mutual coupling: substitution antenna to the test antenna	0,00
u <sub>j12</sub>	mutual coupling: interpolation of mutual coupling and mismatch loss correction factors	0,00
u <sub>i01</sub>	random uncertainty	

The standard uncertainties from table 61 should be combined by RSS in accordance with ETR 273 [12], part 1, subpart 1, clause 5. This gives the combined standard uncertainty ( $u_c$  contribution from the substitution) for the EUT measurement in dB.

### 7.2.3.1.3 Expanded uncertainty

The combined standard uncertainty of the ERP measurement of the spurious emission is the combination of the components outlined in clauses 7.2.3.1.1 and 7.2.3.1.2. The components to be combined are  $u_c$  contribution from the EUT measurement and  $u_c$  contribution from the substitution:

$$u_c = \sqrt{u_{c \text{ contribution from the EUT measurement}}^2 + u_{c \text{ contribution from the substitution}}^2} = \_, \_ \text{ dB}$$

Using an expansion factor (coverage factor) of  $k = 1,96$ , the expanded measurement uncertainty is  $\pm 1,96 \times u_c = \pm \_, \_ \text{ dB}$  (see annex D, clause D.5.6.2 in part 2).

### 7.2.3.2 Anechoic Chamber with a ground plane

#### 7.2.3.2.1 Uncertainty contributions: Stage one: EUT measurement

For the measurement of spurious effective radiated power two stages of test are involved. The first stage (the EUT measurement) is to measure on the receiving device, a level from the EUT as shown in figure 63 (shaded components are common to both stages of the test).

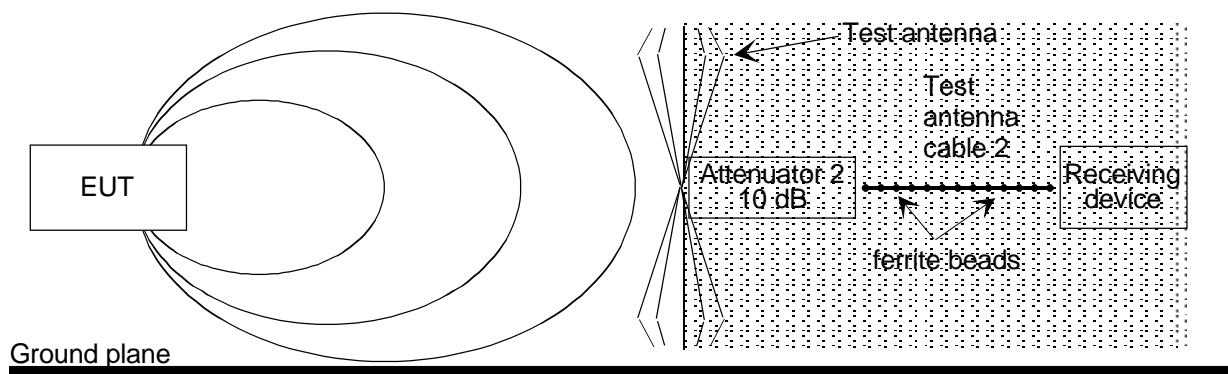

**Figure 63: Stage one: EUT measurement**

Due to the commonality of all of the components from the test antenna to the receiver in both stages of the test, the mismatch uncertainty contributes identically to both stages and hence cancels. Similarly, the systematic uncertainty contributions (e.g. test antenna cable loss, etc.) of the individual components also cancel.

The magnitude of the random uncertainty contribution to this stage of the procedure can be assessed from multiple repetition of the EUT measurement.

All the uncertainty components which contribute to this stage of the test are listed in table 62. Annex A should be consulted for the sources and/or magnitudes of the uncertainty contributions.

**Table 62: Contributions from the measurement on the EUT**

$u_j$ or $i$	Description of uncertainty contributions	dB
$u_{j37}$	mismatch: receiving part	
$u_{j19}$	cable factor: test antenna cable	0,00
$u_{j41}$	insertion loss: test antenna cable	0,00
$u_{j40}$	insertion loss: test antenna attenuator	0,00
$u_{j47}$	receiving device: absolute level	0,00
$u_{j54}$	EUT: influence of setting the power supply on the spurious emission levels	
$u_{j20}$	position of the phase centre: within the EUT volume	
$u_{j21}$	positioning of the phase centre: within the EUT over the axis of rotation of the turntable	
$u_{j51}$	EUT: influence of the ambient temperature on the spurious emission level	
$u_{j16}$	range length	
$u_{j18}$	correction: measurement distance	
$u_{j01}$	reflectivity of absorbing material: EUT to the test antenna	
$u_{j45}$	antenna: gain of the test antenna	0,00
$u_{j46}$	antenna: tuning of the test antenna	0,00
$u_{j55}$	EUT: mutual coupling to the power leads	
$u_{j08}$	mutual coupling: amplitude effect of the test antenna on the EUT	
$u_{j04}$	mutual coupling: EUT to its images in the absorbing material	
$u_{j13}$	mutual coupling: EUT to its image in the ground plane	
$u_{j06}$	mutual coupling: test antenna to its images in the absorbing material	
$u_{j14}$	mutual coupling: test antenna to its image in the ground plane	
$u_{i01}$	random uncertainty	

The standard uncertainties from table 62 should be combined by RSS in accordance with ETR 273 [12], part 1, subpart 1, clause 5. This gives the combined standard uncertainty ( $u_c$  contribution from the EUT measurement) for the EUT measurement in dB.

### 7.2.3.2.2 Uncertainty contributions: Stage two: Substitution measurement

The second stage (the substitution) involves replacing the EUT with a substitution antenna and signal source as shown in figure 64 and adjusting the output level of the signal generator until the same level as in stage one is achieved on the receiving device.

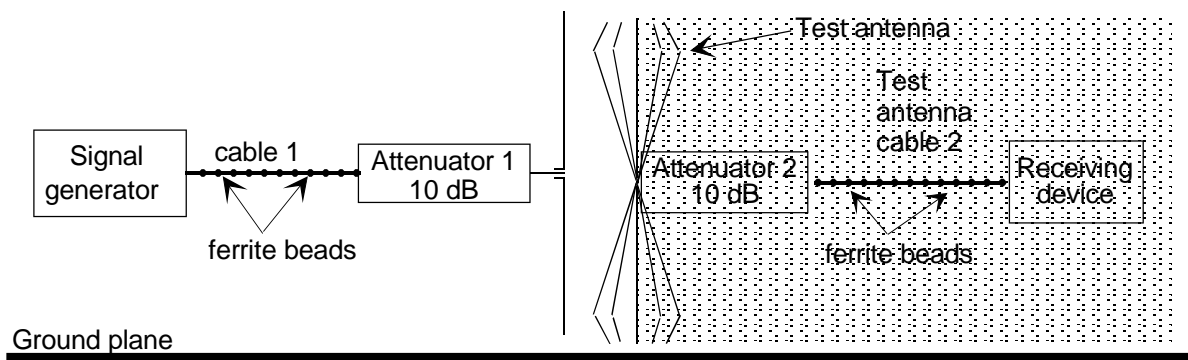

Figure 64: Stage two: Substitution measurement

All the uncertainty components which contribute to this stage of the test are listed in table 63. Annex A should be consulted for the sources and/or magnitudes of the uncertainty contributions.

Table 63: Contributions from the substitution

$u_j$ or $i$	Description of uncertainty contributions	dB
$u_{j36}$	mismatch: transmitting part	
$u_{j37}$	mismatch: receiving part	
$u_{j38}$	signal generator: absolute output level	
$u_{j39}$	signal generator: output level stability	
$u_{j19}$	cable factor: substitution antenna cable	
$u_{j19}$	cable factor: test antenna cable	
$u_{j41}$	insertion loss: substitution antenna cable	
$u_{j41}$	insertion loss: test antenna cable	0,00
$u_{j40}$	insertion loss: substitution antenna attenuator	
$u_{j40}$	insertion loss: test antenna attenuator	0,00
$u_{j47}$	receiving device: absolute level	0,00
$u_{j16}$	range length	0,00
$u_{j18}$	correction: measurement distance	
$u_{j02}$	reflectivity of absorbing material: substitution antenna to the test antenna	
$u_{j45}$	antenna: gain of substitution antenna	
$u_{j45}$	antenna: gain of the test antenna	0,00
$u_{j46}$	antenna: tuning of the substitution antenna	
$u_{j46}$	antenna: tuning of the test antenna	0,00
$u_{j22}$	position of the phase centre: substitution antenna	
$u_{j17}$	correction: off boresight angle in the elevation plane	
$u_{j06}$	mutual coupling: substitution antenna to its images in the absorbing material	
$u_{j06}$	mutual coupling: test antenna to its images in the absorbing material	
$u_{j14}$	mutual coupling: substitution antenna to its image in the ground plane	
$u_{j14}$	mutual coupling: test antenna to its image in the ground plane	
$u_{j11}$	mutual coupling: substitution antenna to the test antenna	
$u_{j12}$	mutual coupling: interpolation of mutual coupling and mismatch loss correction factors	
$u_{i01}$	random uncertainty	

The standard uncertainties from table 63 should be combined by RSS in accordance with ETR 273 [12], part 1, subpart 1, clause 5. This gives the combined standard uncertainty ( $u_c$  contribution from the substitution) for the EUT measurement in dB.

### 7.2.3.2.3 Expanded uncertainty

The combined standard uncertainty of the ERP measurement of the spurious emission is the combination of the components outlined in clauses 7.2.3.2.1 and 7.2.3.2.2. The components to be combined are  $u_c$  contribution from the EUT measurement and  $u_c$  contribution from the substitution:

$$u_c = \sqrt{u_{c \text{ contribution from the EUT measurement}}^2 + u_{c \text{ contribution from the substitution}}^2} = \dots \text{ dB}$$

Using an expansion factor (coverage factor) of  $k = 1,96$ , the expanded measurement uncertainty is  $\pm 1,96 \times u_c = \pm \dots \text{ dB}$  (see annex D, clause D.5.6.2 in part 2).

### 7.2.3.3 Open Area Test Site

#### 7.2.3.3.1 Uncertainty contributions: Stage one: EUT measurement

For the measurement of spurious effective radiated power two stages of test are involved. The first stage (the EUT measurement) is to measure on the receiving device, a level from the EUT as shown in figure 65 (shaded components are common to both stages of the test).

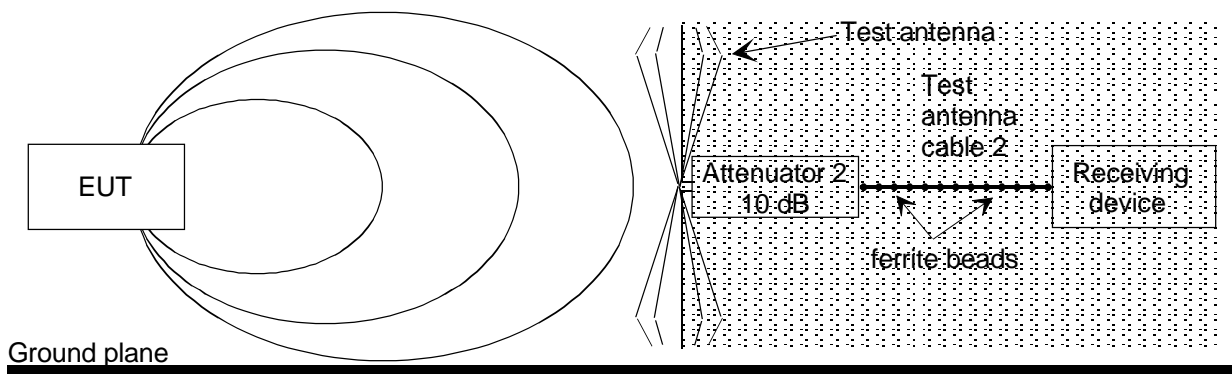

**Figure 65: Stage one: EUT measurement**

Due to the commonality of all of the components from the test antenna to the receiver in both stages of the test, the mismatch uncertainty contributes identically in each stage and hence cancels. Similarly, the systematic uncertainty contributions (e.g. test antenna cable loss, etc.) of the individual components also cancel.

The magnitude of the random uncertainty contribution to each stage of the procedure can be assessed from multiple repetition of the EUT measurement.

All the uncertainty components which contribute to this stage of the test are listed in table 64. Annex A should be consulted for the sources and/or magnitudes of the uncertainty contributions.

**Table 64: Contributions from the measurement on the EUT**

$u_j$ or $i$	Description of uncertainty contributions	dB
$u_{j37}$	mismatch: receiving part	
$u_{j19}$	cable factor: test antenna cable	0,00
$u_{j41}$	insertion loss: test antenna cable	0,00
$u_{j40}$	insertion loss: test antenna attenuator	0,00
$u_{j47}$	receiving device: absolute level	0,00
$u_{j54}$	EUT: influence of setting the power supply on the spurious emission level	
$u_{j20}$	position of the phase centre: within the EUT volume	
$u_{j21}$	positioning of the phase centre: within the EUT over the axis of rotation of the turntable	
$u_{j51}$	EUT: influence of the ambient temperature on the spurious emission level	
$u_{j16}$	range length	
$u_{j18}$	correction: measurement distance	
$u_{j45}$	antenna: gain of the test antenna	0,00
$u_{j46}$	antenna: tuning of the test antenna	0,00
$u_{j55}$	EUT: mutual coupling to the power leads	
$u_{j08}$	mutual coupling: amplitude effect of the test antenna on the EUT	
$u_{j13}$	mutual coupling: EUT to its images in the ground plane	
$u_{j14}$	mutual coupling: test antenna to its images in the ground plane	
$u_{i01}$	random uncertainty	

The standard uncertainties from table 64 should be combined by RSS in accordance with ETR 273 [13], part 1, subpart 1, clause 5. This gives the combined standard uncertainty ( $u_c$  contribution from the EUT measurement) for the EUT measurement in dB.

#### 7.2.3.3.2 Uncertainty contributions: Stage two: Substitution measurement

The second stage (the substitution) involves replacing the EUT with a substitution antenna and signal source as shown in figure 66 and adjusting the output level of the signal generator until the same level as in stage one is achieved on the receiving device.

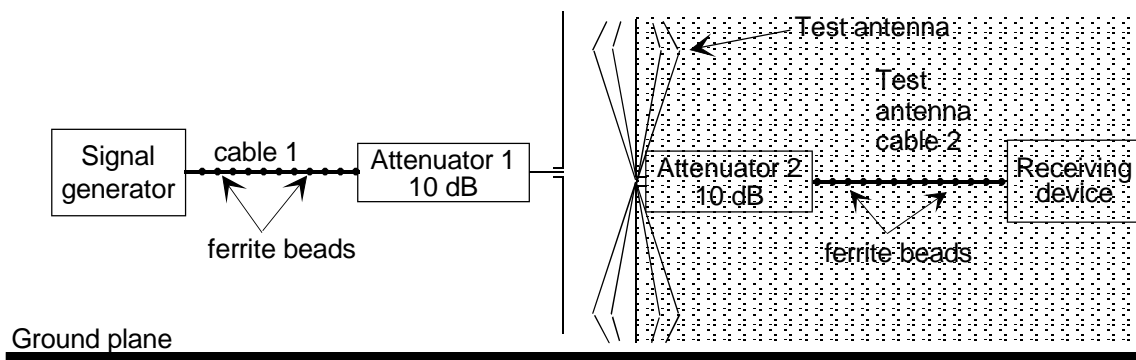
**Figure 66: Stage two: Typical emission substitution test**

All the uncertainty components which contribute to this stage of the test are listed in table 65. Annex A should be consulted for the sources and/or magnitudes of the uncertainty contribution.

Table 65: Contributions from the substitution

$u_j$ or $i$	Description of uncertainty contributions	dB
$U_{j36}$	mismatch: transmitting part	
$U_{j37}$	mismatch: receiving part	
$U_{j38}$	signal generator: absolute output level	
$U_{j39}$	signal generator: output level stability	
$U_{j19}$	cable factor: substitution antenna cable	
$U_{j19}$	cable factor: test antenna cable	
$U_{j41}$	insertion loss: substitution antenna cable	
$U_{j41}$	insertion loss: test antenna cable	0,00
$U_{j40}$	insertion loss: substitution antenna attenuator	
$U_{j40}$	insertion loss: test antenna attenuator	0,00
$U_{j47}$	receiving device: absolute level	0,00
$U_{j16}$	range length	0,00
$U_{j18}$	correction: measurement distance	
$U_{j45}$	antenna: gain of the substitution antenna	
$U_{j45}$	antenna: gain of the test antenna	0,00
$U_{j46}$	antenna: tuning of the substitution antenna	
$U_{j46}$	antenna: tuning of the test antenna	0,00
$U_{j22}$	position of the phase centre: substitution antenna	
$U_{j17}$	correction: off boresight angle in the elevation plane	
$U_{j14}$	mutual coupling: substitution antenna to its image in the ground plane	
$U_{j14}$	mutual coupling: test antenna to its image in the ground plane	
$U_{j11}$	mutual coupling: substitution antenna to the test antenna	
$U_{j12}$	mutual coupling: interpolation of mutual coupling and mismatch loss correction factors	
$U_{i01}$	random uncertainty	

The standard uncertainties from table 65 should be combined by RSS in accordance with ETR 273 [12], part 1, subpart 1, clause 5. This gives the combined standard uncertainty ( $u_c$  contribution from the substitution) for the EUT measurement in dB.

### 7.2.3.3.3 Expanded uncertainty

The combined standard uncertainty of the ERP measurement of the spurious emission is the combination of the components outlined in clauses 7.2.6.1 and 7.2.6.2. The components to be combined are  $u_c$  contribution from the EUT measurement and  $u_c$  contribution from the substitution:

$$u_c = \sqrt{u_{c \text{ contribution from the EUT measurement}}^2 + u_{c \text{ contribution from the substitution}}^2} = \_, \_ \text{ dB}$$

Using an expansion factor (coverage factor) of  $k = 1,96$ , the expanded measurement uncertainty is  $\pm 1,96 \times u_c = \pm \_, \_ \text{ dB}$  (see annex D, clause D.5.6.2 in part 2).

### 7.2.3.4 Stripline

This test is not usually performed in a Stripline and is therefore not considered here.

### 7.2.3.5 Test fixture

This test is not normally carried out in a test fixture.

## 7.2.4 Adjacent channel power

### 7.2.4.1 Anechoic Chamber

This test is normally carried out using a test fixture and as a result has not been considered for the Anechoic Chamber.

### 7.2.4.2 Anechoic Chamber with a ground plane

This test is normally carried out using a test fixture and as a result has not been considered for the Anechoic Chamber with a ground plane.

### 7.2.4.3 Open Area Test Site

This test is normally carried out using a test fixture and as a result has not been considered for the Open Area Test Site.

### 7.2.4.4 Stripline

This test is normally carried out using a test fixture and as a result has not been considered for the Strip line.

### 7.2.4.5 Test fixture

The uncertainty contributions for the test are shown in table 66.

NOTE: Some standards require the adjacent channel power to be 60 dBc without the need for it to fall below 250 nW. In this case, both values (absolute and dBc) are required as, for example, 40 dBc is considered satisfactory if the adjacent channel power is < 250 nW.

#### 7.2.4.5.1 Contributions from the measurement

**Table 66: Contributions from the measurement**

$u_j$ or $i$	Description of uncertainty contributions	dB
$u_{j48}$	receiving device: linearity	
$u_{j49}$	receiving device: power measuring receiver	
$u_{j50}$	EUT: influence of the ambient temperature on the ERP of the carrier	
$u_{j53}$	EUT: influence of setting the power supply on the ERP of the carrier	
$u_{j60}$	Test Fixture: effect on the EUT	
$u_{j61}$	Test Fixture: climatic facility effect on the EUT	
$u_{i01}$	random uncertainty	

The standard uncertainties from table 66 should be given values according to annex A. They should then be combined by RSS in accordance with ETR 273 [12], part 1, subpart 1, clause 5. This gives the combined standard uncertainty ( $u_c$  contributions from the measurement) for the EUT measurement in dB.

#### 7.2.4.5.2 Expanded uncertainty

For a relative measurement (dBc) of adjacent channel power, the combined uncertainty,  $u_c$ , of the measurement is simply the value for  $u_c$  contributions from the measurement derived above.

Using an expansion factor (coverage factor) of  $k = 1,96$ , the expanded measurement uncertainty is  $\pm 1,96 \times u_c = \pm \_, \_ \text{ dB}$  (see annex D, clause D.5.6.2 in part 2).

For those test standards that require the adjacent channel power to be given in absolute terms, however, for the calculation of the measurement uncertainty, the Test Fixture measurement should be considered as stage two of a test in which stage one was on an accredited Free-Field Test Site. The combined standard uncertainty,  $u_c$ , of the adjacent channel power measurement is therefore, simply the RSS combination of the value for  $u_c$  contributions from the measurement derived above and the combined uncertainty of the Free-field Test Site  $u_c$  contribution from the Free-Field Test Site:

$$u_c = \sqrt{u_c^2 \text{ contributions from the measurement} + u_c^2 \text{ contributions from the free-field test site}} = \_, \_ \text{ dB}$$

Using an expansion factor (coverage factor) of  $k = 1,96$ , the expanded measurement uncertainty is  $\pm 1,96 \times u_c = \pm \_, \_ \text{ dB}$  (see annex D, clause D.5.6.2 in part 2).

---

# History

<b>Document history</b>		
Edition 1	March 1992	Publication as ETR 028
Edition 2	March 1994	Publication as ETR 028
V1.3.1	March 2001	Publication