



**ETSI**  
**TECHNICAL COMMITTEE**  
**REFERENCE TECHNICAL REPORT**

**TCR-TR 014**

October 1993

Source: ETSI TC-TM

Reference: DTR/TM-3010

ICS: 33.080

**Key words:** Architecture, transport, ATM

**Transmission and Multiplexing (TM);  
Harmonisation of transport network architecture  
and protocol reference model for the transport of  
Asynchronous Transfer Mode (ATM) cells**

**ETSI**

European Telecommunications Standards Institute

**ETSI Secretariat**

**Postal address:** F-06921 Sophia Antipolis CEDEX - FRANCE

**Office address:** 650 Route des Lucioles - Sophia Antipolis - Valbonne - FRANCE

**X.400:** c=fr, a=atlas, p=etsi, s=secretariat - **Internet:** secretariat@etsi.fr

Tel.: +33 92 94 42 00 - Fax: +33 93 65 47 16

**Copyright Notification:** No part may be reproduced except as authorized by written permission. The copyright and the foregoing restriction extend to reproduction in all media.

© European Telecommunications Standards Institute 1993. All rights reserved.



## Contents

Foreword .....	5
1 Scope .....	7
2 References .....	7
3 Definitions, symbols and abbreviations .....	7
4 Introduction.....	8
5 Terminology.....	8
6 Generic concepts applied to ATM transport network .....	8
7 Transport entities and transport functions.....	9
7.1 Transport entities .....	9
7.2 Transport functions.....	9
7.3 Network topology examples.....	10
7.4 Possible correspondence between PRM and functional architecture.....	10
7.5 Point to multipoint connections .....	10
8 Description of protection and maintenance mechanisms .....	11
8.1 Subnetwork monitoring .....	11
8.2 Protection.....	11
8.2.1 VP/VC network layer 1+1 protection .....	11
8.2.1.1 VPNC/VCNC 1+1 protection.....	11
8.2.1.2 VP/VC subnetwork connection 1+1 protection .....	11
8.2.2 1:N Protection.....	12
9 Harmonisation of vocabulary.....	12
Annex A: Harmonisation of vocabulary between CCITT Recommendations I.311 and G.803 .....	21
A.1 ATM network layering.....	21
A.2 Topological components inside a layer network.....	21
A.3 Transport entities and transport functions.....	21
A.4 Reference points .....	21
History.....	22

Blank page

## **Foreword**

This draft Technical Committee Reference Technical Report (TCR-TR) has been produced by Transmission and Multiplexing (TM) Technical Committee of the European Telecommunications Standards Institute (ETSI), with the co-operation of ETSI STCs TM3 and NA5.

Blank page

## 1 Scope

This TCR-TR is an attempt to harmonise the description of the functional architecture of transport networks based on the Synchronous Digital Hierarchy (SDH) and the Asynchronous Transfer Mode (ATM) networking techniques based on the B-ISDN protocol reference model developed respectively in TM3 and NA5 STCs. It should also include harmonisation of the vocabulary.

## 2 References

For the purposes of this TCR-TR, the following references are used.

- [1] CCITT Recommendation I.113 (1991): "Vocabulary of terms for broadband aspects of ISDN".
- [2] CCITT Recommendation I.311 (1991): "B-ISDN general network aspects".
- [3] CCITT Recommendation I.321 (1991): "B-ISDN protocol reference model and its application".
- [4] CCITT Recommendation I.327 (1991): "B-ISDN functional architecture".
- [5] CCITT Recommendation I.610 (1991): "OAM principles of the B-ISDN access".
- [6] CCITT Recommendation G.803: "Architecture of transport networks based on the SDH", CCITT, XVIII/7, Q4, June 1992 version.
- [7] ETR 085: "Generic functional architecture of transport networks" (DTR/TM-3016).

## 3 Definitions, symbols and abbreviations

Generic definitions, symbols and abbreviations of transport network architecture are in ETR 085 [7]. Definitions, symbols and abbreviations related to ATM networks are provided in I. series of CCITT Recommendations.

AF	Adaptation Function (see ETR 085 [7])
AP	Access Point (see ETR 085 [7])
ATM	Asynchronous transfer mode (see CCITT Recommendation I.113 [1])
CP	Connection Point (see ETR 085 [7])
F4	maintenance flow at the VP level (see CCITT Recommendation I.610 [5])
F5	maintenance flow at the VC level (see CCITT Recommendation I.610 [5])
NC	Network Connection (see ETR 085 [7])
OAM cells	dedicated cells used to support maintenance flows such as F4 and F5 (see CCITT Recommendation I.610 [5])
OAM flows	generic term for maintenance flows such as F4 and F5 (see CCITT Recommendation I.610 [5])
PRM	protocol reference model for B-ISDN (see CCITT Recommendation I.321 [3])
TCP	Termination Connection Point (see ETR 085 [7])
TTF	Trail Termination Function (see ETR 085 [7])
VC	Virtual Channel (see CCITT Recommendation I.113 [1])
VCC	Virtual Channel Connection (see CCITT Recommendation I.311 [2])
VCI	Virtual Channel Identifier (see CCITT Recommendation I.113 [1])
VCLC	Virtual Channel Link Connection
VCNC	Virtual Channel Network Connection
VCSC	Virtual Channel Subnetwork Connection
VCSW	Virtual Channel Switch
VP	Virtual Path (see CCITT Recommendation I.113 [1])
VPC	Virtual Path Connection (see CCITT Recommendation I.311 [2])
VPI	Virtual Path Identifier (see CCITT Recommendation I.113 [1])
VPLC	Virtual Path Link Connection
VPNC	Virtual Path Network Connection
VPSC	Virtual Path Subnetwork Connection

## 4 Introduction

It is of prime importance for the design and operation of telecommunication networks in a multi-vendor and multi-operator environment to develop commonality between the specification of management standards, performance capabilities, operation and maintenance of transport networks and equipment of various technologies. As a prerequisite for this work harmonisation of the functional architecture of transport networks based on different technologies is required. In particular it is necessary to harmonise the description of the functional architecture of transport networks based on the SDH developed in ETSI/STC TM3 and in CCITT WP XVIII/7 and the ATM networking techniques based on the B-ISDN protocol reference model based on ATM and using PDH, SDH or cell-based physical layer options developed in ETSI/STC NA5 and CCITT WP XVIII/8.

This TCR-TR proposes a description of ATM transport network, based on the tools defined in CCITT Recommendation G.803 [6] sections 2 and 3. Both sections are concerned with the generic principles of transport network architecture, independent of networking technology. The work aims at the creation of a new generic ETS (G.tna-DE/TM-3014), basis of a set including also three specific ETSs for ATM, SDH, PDH.

This architecture is meant to be taken as a reference for the specifications of:

- functional blocks of ATM network elements;
- management model of ATM network elements.

Clause 5 is a terminology list.

Clause 6 shows how the generic concepts of CCITT Recommendation G.803 [6] can be applied to the VP and VC layers of an ATM transport network.

Clause 7 defines the transport entities and functions involved.

Clause 8 contains a precise description of protection and maintenance mechanisms based on these entities and functions.

Clause 9 is related to the harmonisation of vocabulary.

## 5 Terminology

For further study.

## 6 Generic concepts applied to ATM transport network

The term "layer network" which is used in this TCR-TR is defined in section 3.2.1.1 of CCITT Recommendation G.803 [6]. A layer network is defined by the complete set of like access points which may be associated for the purpose of transferring information. All of those access points (AP) are of the same type: that means the information transferred has a given format which is characteristic of a layer network. A transport network is usually made of several layer networks, built one upon another.

The ATM transport network backbone is made of VC layer network and VP layer network. Figure 1 shows all the transport entities and transport functions required to connect two access points in the VC layer network (top of figure 1) and to connect two access points in the VP layer network (bottom of figure 1). Those transport entities and functions are detailed in the next sections.



## 7 Transport entities and transport functions

### 7.1 Transport entities

The generic transport entity used to connect two access points is a trail. Furthermore, a trail is responsible for the integrity of the information transferred between access points. In the VC layer network it can be named a VC trail. In the VP layer network it can be named a VP trail.

The other basic transport entity is a connection. A connection transfers information but does not insure the integrity of the transfer. A trail is made of several connections in series bound together. Two kinds of connections are defined.

A link connection is a transport entity provided by the client/server association. It is formed by a near end adaptation function, a trail and a far end adaptation function. It can be configured as part of the trail management process in the associated server layers.

A subnetwork connection is a transport entity formed by a connection across a subnetwork. It can be configured as part of the trail management process.

The points where link connections are bound to subnetwork connections are named Connection Points (CPs). The complete set of link connections and subnetwork connections bound together is called a network connection.

The way in which a network connection is partitioned in link connections and subnetwork connections mirror a more general concept: the partitioning of a layer network into subnetwork and links.

Subnetworks and links are a topological description of a layer network. A subnetwork is defined by the complete set of like connection points which may be associated for the purpose of transferring information. Subnetworks provide flexible connectivity represented by subnetwork connections between those connections points. A subnetwork may be contained in one physical node.

A link is defined by the sub-set of connection points in one subnetwork which are associated with a sub-set of connection points in another subnetwork for the purpose of transferring information between subnetworks. A link provides static connectivity represented by link connections.

### 7.2 Transport functions

A trail is formed by combining a near end Trail Termination Function (TTF), a network connection, and a far end trail termination function as shown in figure 2. The point where a trail termination function is bound to a network connection is a Termination Connection Point (TCP).

TTFs are in charge of inserting/extracting and processing overheads to insure the integrity of the information transferred between access points.

For the VC layer network, overheads are F5 cells; for the VP layer network, overheads are F4 cells. Both are inserted by a source trail termination function and extracted and processed by a sink trail termination function.

Therefore, network connections in the VP layer network and in the VC layer network, as shown in figure 1, are named Virtual Path Network Connection (VPNC) and Virtual Channel Network Connection (VCNC). They transport both the information presented at the access point and the overheads (F4 or F5 cells) used to monitor this information.

The trails in the VC layer network and in the VP layer network are equivalent to the VC Connection (VCC) and the VP Connection (VPC) as defined in CCITT Recommendation I.311 [2].

The other transport function is the adaptation function (AF). The adaptation function represents the association between a connection point in the client layer network and an access point in the server layer network. The information at a connection point in the client layer network is adapted to a form suitable for transport in the server layer network. Therefore, a link connection in the client layer network is provided by a trail in the server layer network.

For ATM transport network it means that a VP trail and a VPNC is used to transport a VC link connection as shown in figure 1. In fact more than one VC link connection might be transported by a VP trail and a VPNC. The adaptation function in the VP layer network multiplexes cells from different VC link connections into a VP trail and vice versa.

The VC layer normally is a circuit layer network in direct support of telecommunications services and as such the modelling concepts of CCITT Recommendation G.803 [6] do not apply above the VC layer. An adaptation function for the VC layer as a server (e.g. circuit emulation by ATM) would be client layer dependent. Whether this is required is for further study.

### **7.3 Network topology examples**

Figure 3a shows a VC trail formed by a VC link connection and a VC subnetwork connection (across a VC switch). Each VC link connection is provided by a VP trail. This representation is implementation independent. It may correspond to various network topologies and equipment configurations. Some examples are shown in figures 3b, 3c, and 3d:

- figure 3b shows at the VP level two VP layer networks which are not interconnected;
- figure 3c shows at the VP level one single VP layer network;
- for these two figures it is assumed that the VC switch has no VP cross-connect functions. On the contrary in Figure 3d the VC switch is also a VP cross-connect.

### **7.4 Possible correspondence between PRM and functional architecture**

Some of the functions identified in the Protocol Reference Model (PRM) can be directly mapped onto the CCITT Recommendation G.803 [6] functional blocks.

Other PRM functions need to be split further before being mapped onto the CCITT Recommendation G.803 [6] functional blocks.

Specifically the VP Identifier/VC Identifier (VPI/VCI) translation function is to be split into:

- VPI (de)allocation function mapped onto the adaptation function between the VP layer network and the path layer network;
- a VCI (de)allocation function mapped onto the adaptation function between the VC layer network and the VP layer network.

### **7.5 Point to multipoint connections**

For further study.

## **8 Description of protection and maintenance mechanisms**

### **8.1 Subnetwork monitoring**

Subnetworks may define the administrative boundaries between network operators jointly providing an end to end network connection within a single layer network.

There is a need to monitor independently each subnetwork connection. For the VP and the VC layer network, this can be done by inserting/extracting and processing F4 and F5 type cells at each end of the subnetwork connection (CCITT Recommendation I.610 [5]).

From an architectural point of view, this is done by creating a sublayer network. Within this sublayer network (shaded area in figure 5), a trail provides the integrity of the transport of the information through the subnetwork connection. The trail termination functions insert/extract and process F4 or F5 type cells.

The adaptation function within this sublayer network has no cell multiplexing/demultiplexing functions.

Another network topology with other administrative boundaries is shown in figure 6a, and the associated sublayering representations are shown in figures 6b and 6c.

### **8.2 Protection**

#### **8.2.1 VP/VC network layer 1+1 protection**

The protection concepts are applicable to VP and VC layer network.

##### **8.2.1.1 VPNC/VCNC 1+1 protection**

The figure 7 is an example of end to end VPNC/VCNC 1+1 protection where one trail (VP or VC) is composed of two network connections (VPNC or VCNC). The trail termination source has one input and two outputs. The information at the access point is duplicated on the two Termination Connection Points (TCPs). This source trail termination function inserts redundancy information necessary to the supervision (F4 or F5 flows). The redundancy information is delivered to the two sink TCP.

The trail termination function sink (at right on figure 7) has two inputs and one output. That means that both OAM cells flow are continuously monitored. The choice of the association between one of the TCP and the AP depends on F4/F5 cells monitoring. Furthermore the sink trail termination function extracts those cells.

##### **8.2.1.2 VP/VC subnetwork connection 1+1 protection**

Figure 8 is an example of subnetwork connection 1+1 protection. In the new created sublayer network (see section 8.2 on "Subnetwork monitoring"), the trail (VP or VC) is supported by two network connections (VPNC or VCNC).

This trail uses its own F4/F5 flows for supervision. Trail termination functions work as described previously for the VPNC/VCNC 1+1 protection. This supervision ought not to disturb the client layer network trail supervision.

VPNC/VCNC protection and VP/VC subnetwork connection protection can be supplied by breaking one trail into two network connections as explained previously, but also by breaking up one trail into N network connections (1 : N protection).

### 8.2.2 1:N Protection

In this case of 1:N protection one supplement trail is used to protect N trails established between one network element and another network element. Figure 9 is an example of 1:2 protection.

The supplement trail (shaded area in figure 9) does not transport any client server information, it is supervised only.

If one failure is detected on one of the N trails, the network connection of the deficient trail is switched on the network connection of the supplement trail. The detailed mechanism of the switching function is for further study.

## 9 Harmonisation of vocabulary

Figure 10 compares the terms used in CCITT Recommendations G.803 [6] and I.311 [2] for the application of the functional architecture to a mixed technology network configuration. The harmonisation of the vocabulary is for further study. Annex A contains a list of terms where harmonisation between CCITT Recommendations I.311 [2] and G.803 [6] is desirable.

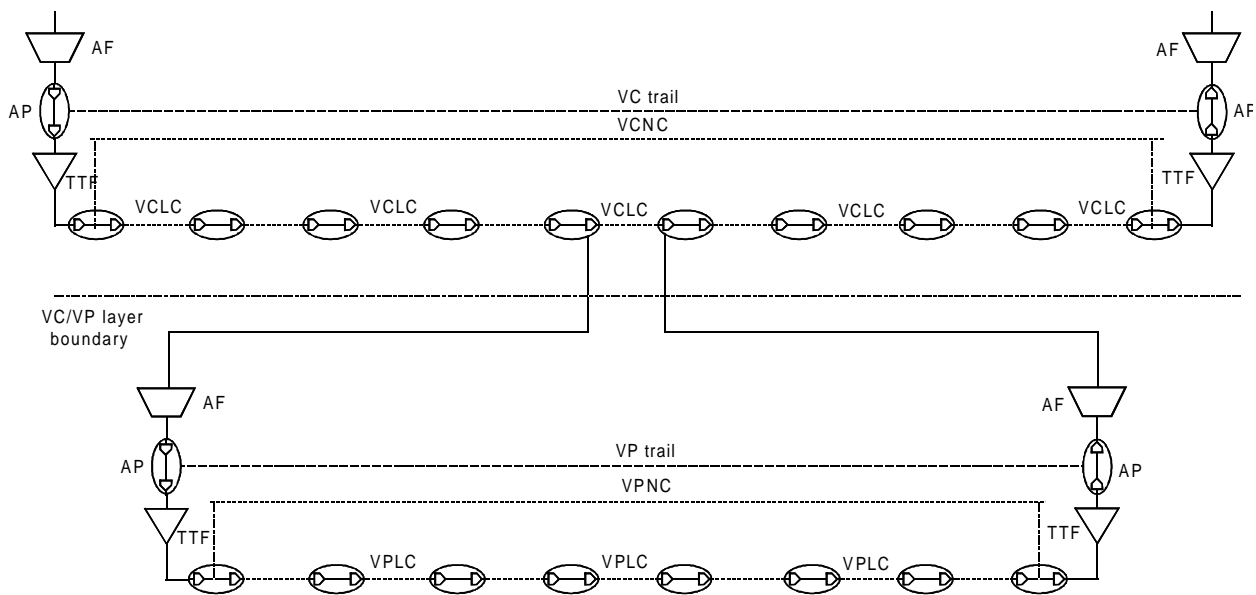

Figure 1: Generic concepts applied to ATM transport network

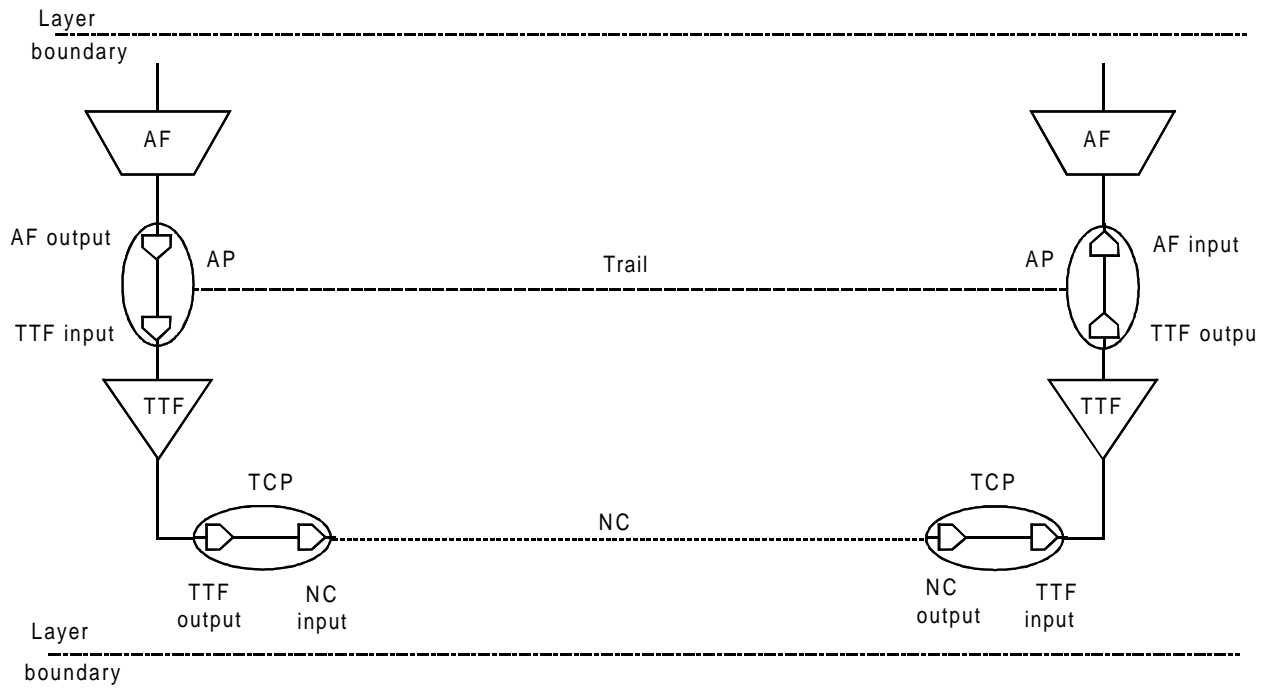
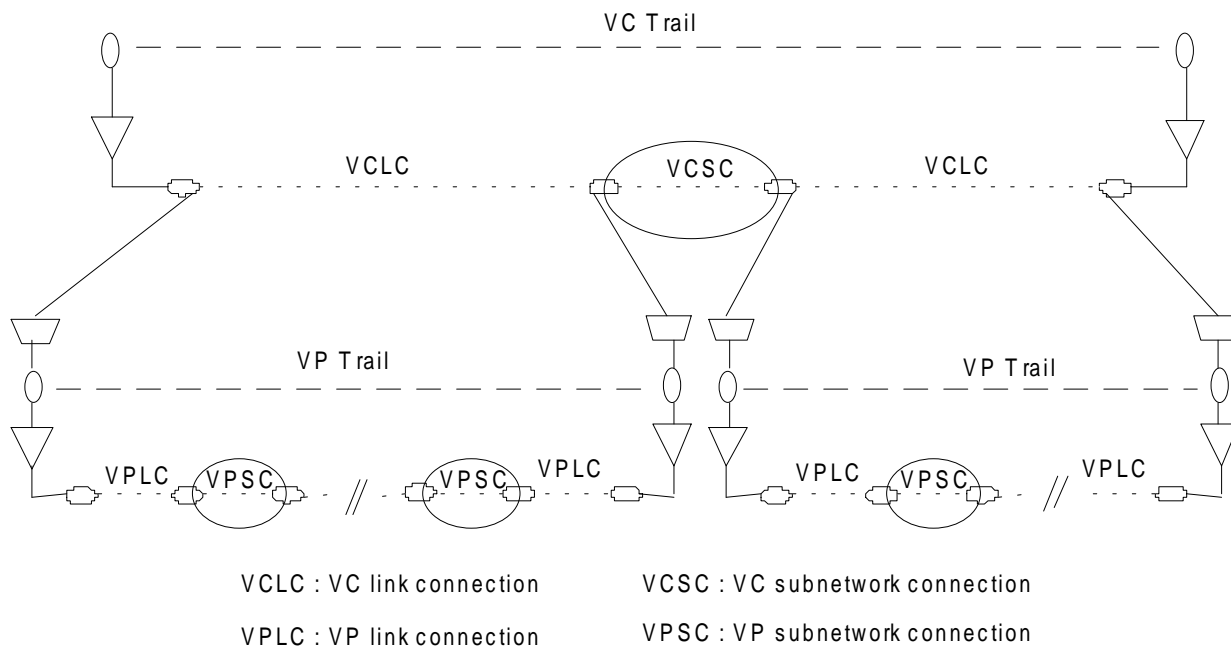
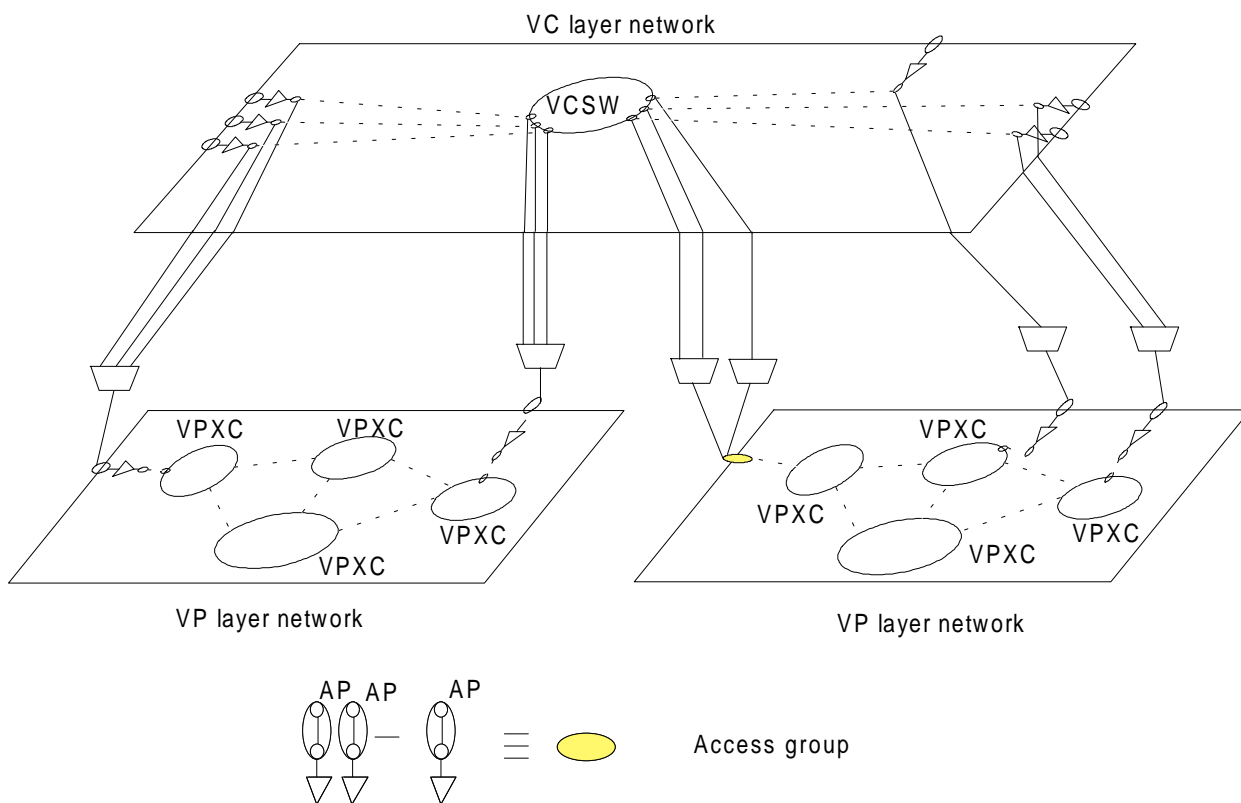

Figure 2: End transport entities/functions



**Figure 3a: A given VC trail configuration**



**Figure 3b: possible network topology corresponding to figure 3a**

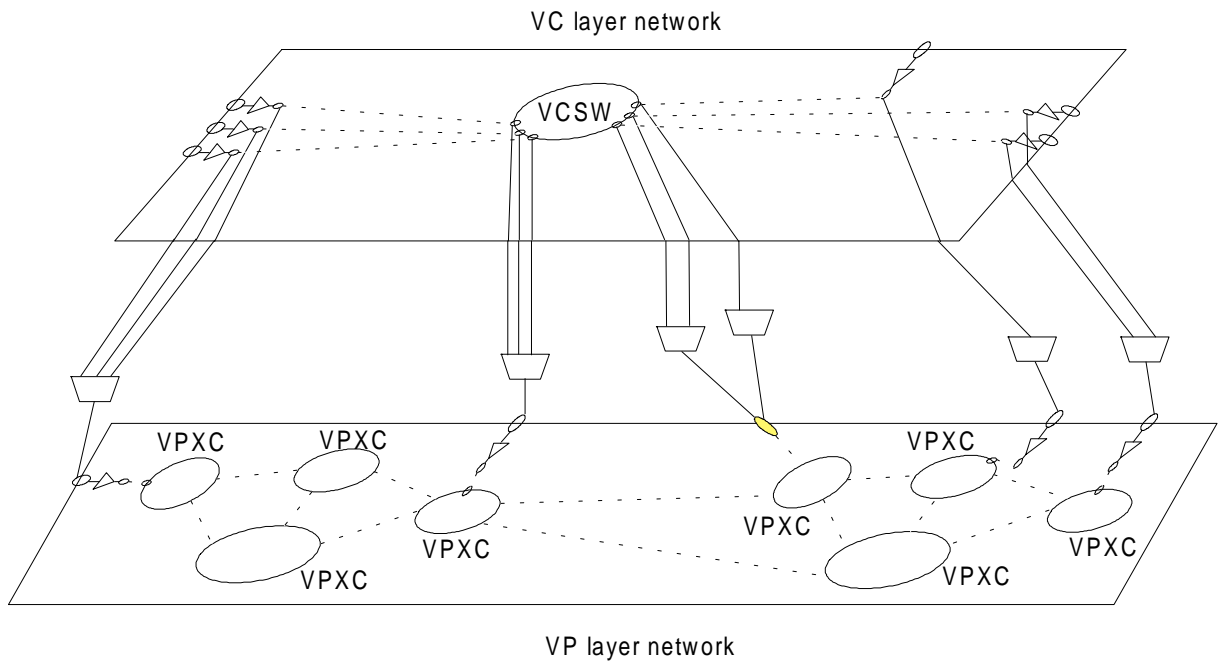

Figure 3c: Possible network topology corresponding to figure 3a

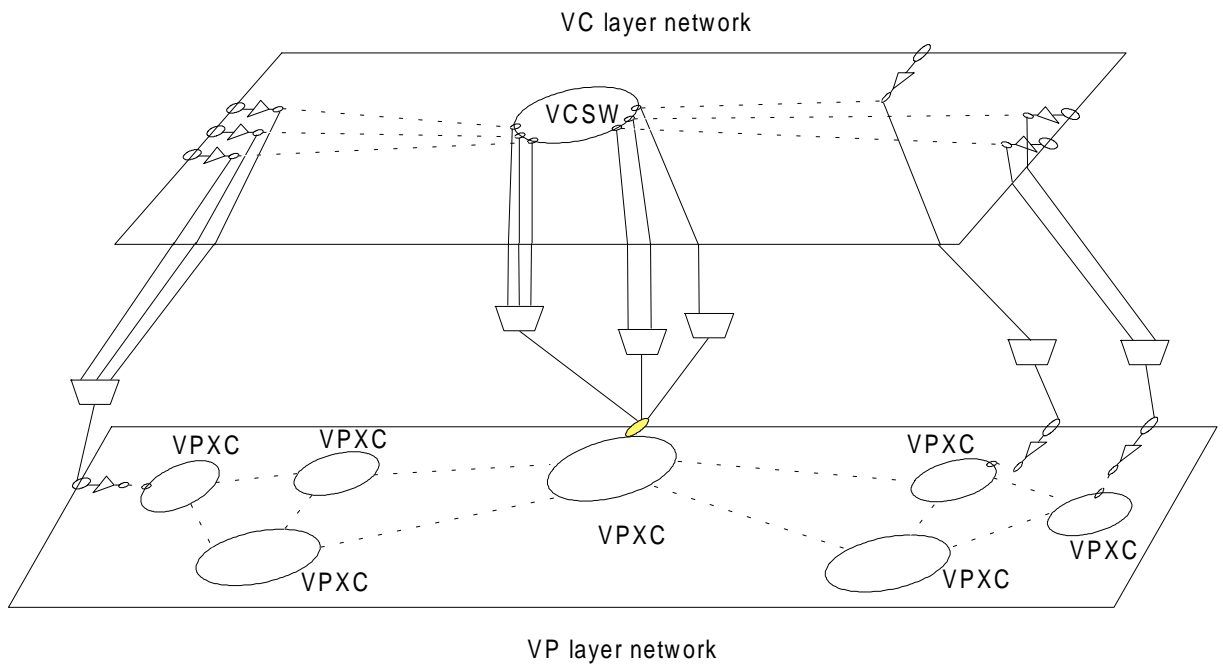
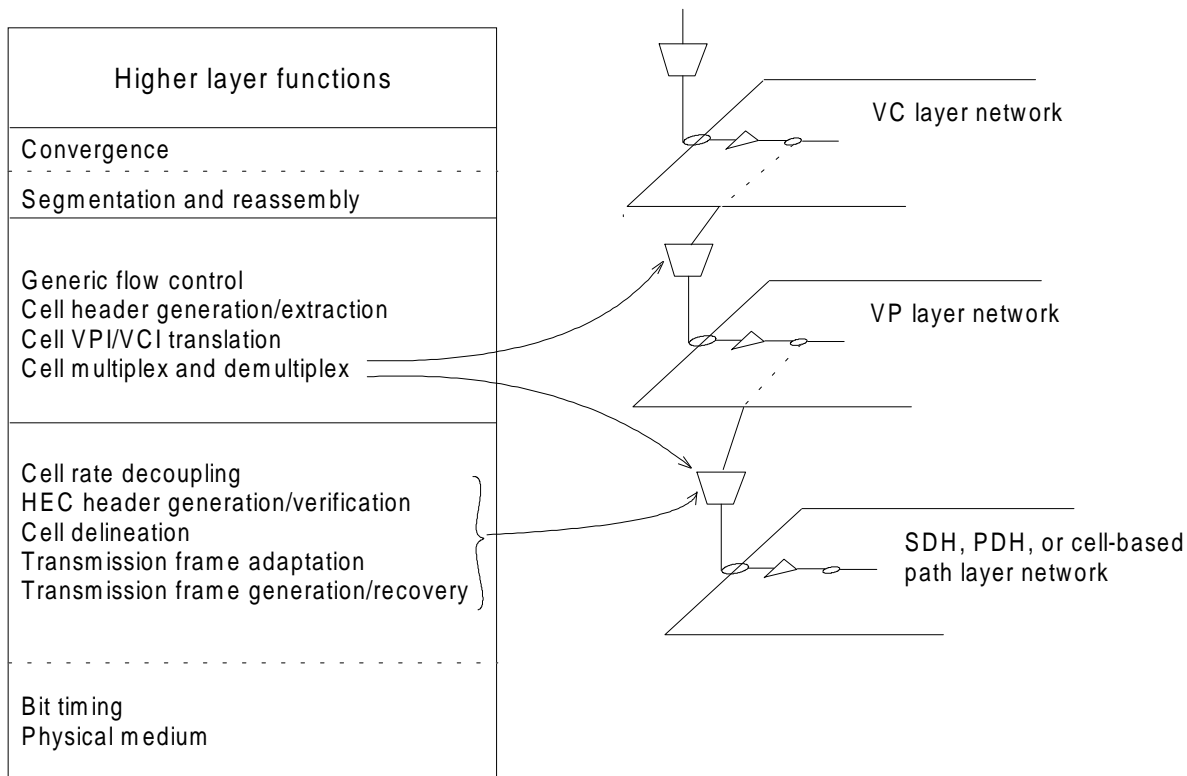
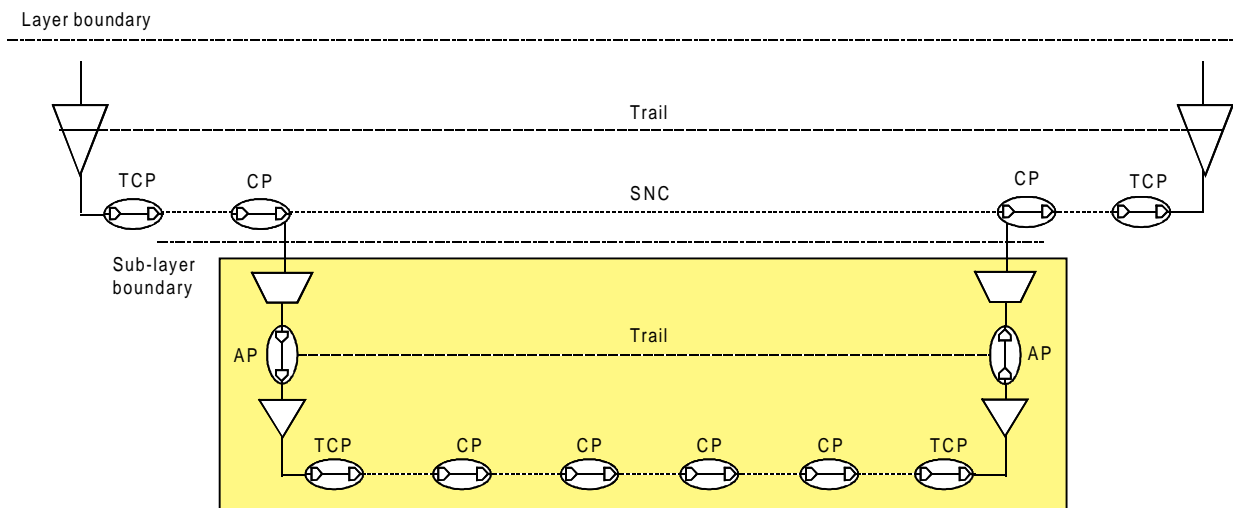

Figure 3d: Possible network topology corresponding to figure 3a



**Figure 4: Allocation of PRM functions to transport functions of layer networks**



**Figure 5: Sub-network monitoring**





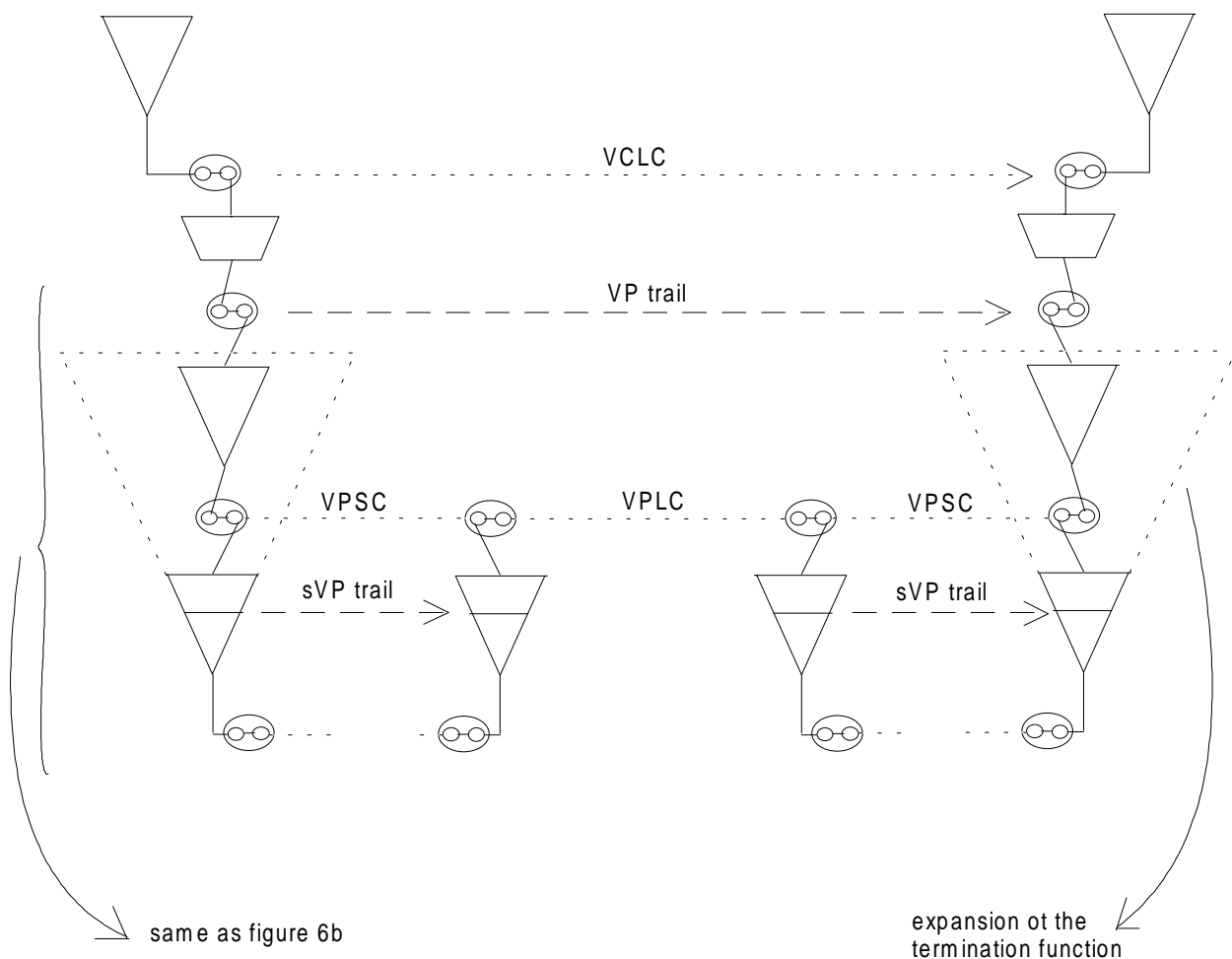

**Figure 6c: Sublayering for VP tandem connection monitoring**

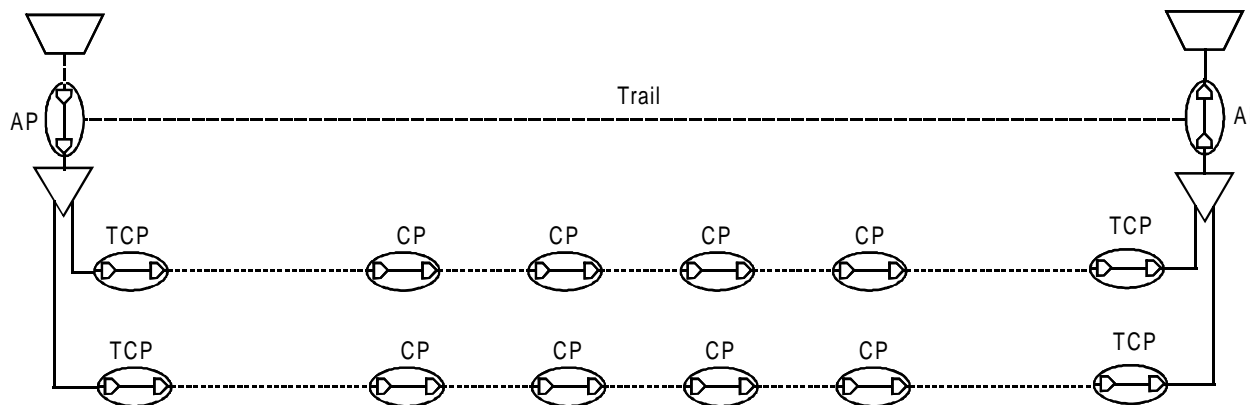

**Figure 7: VPNC/VCNC 1+1 protection**

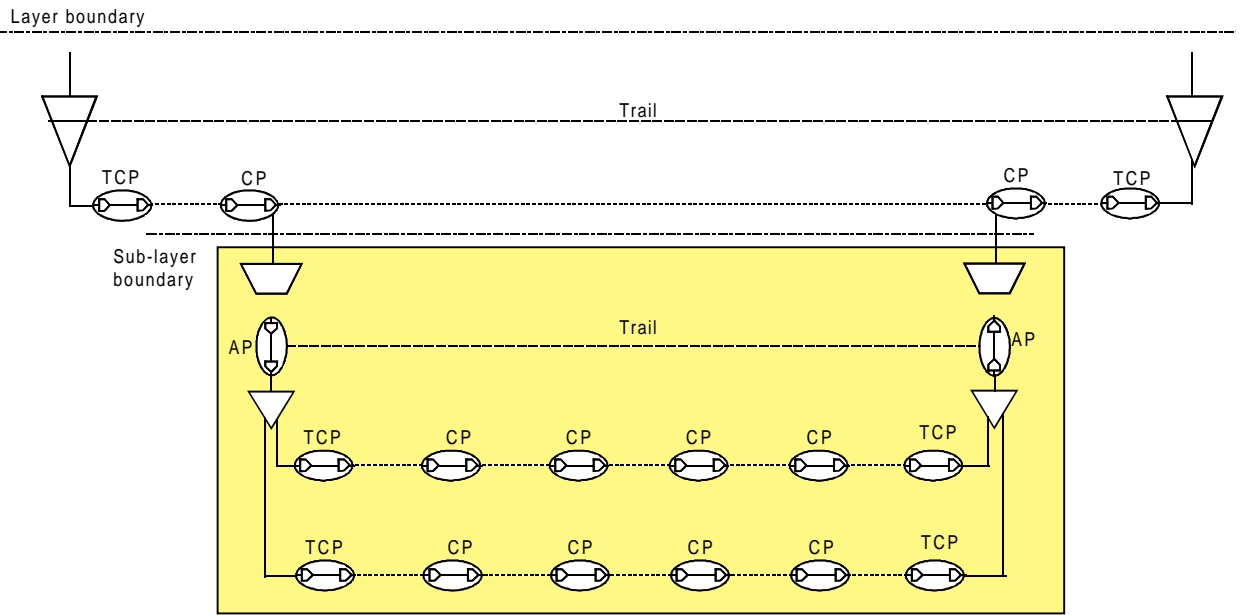

Figure 8: VP/VC sub-network connection 1+1 protection

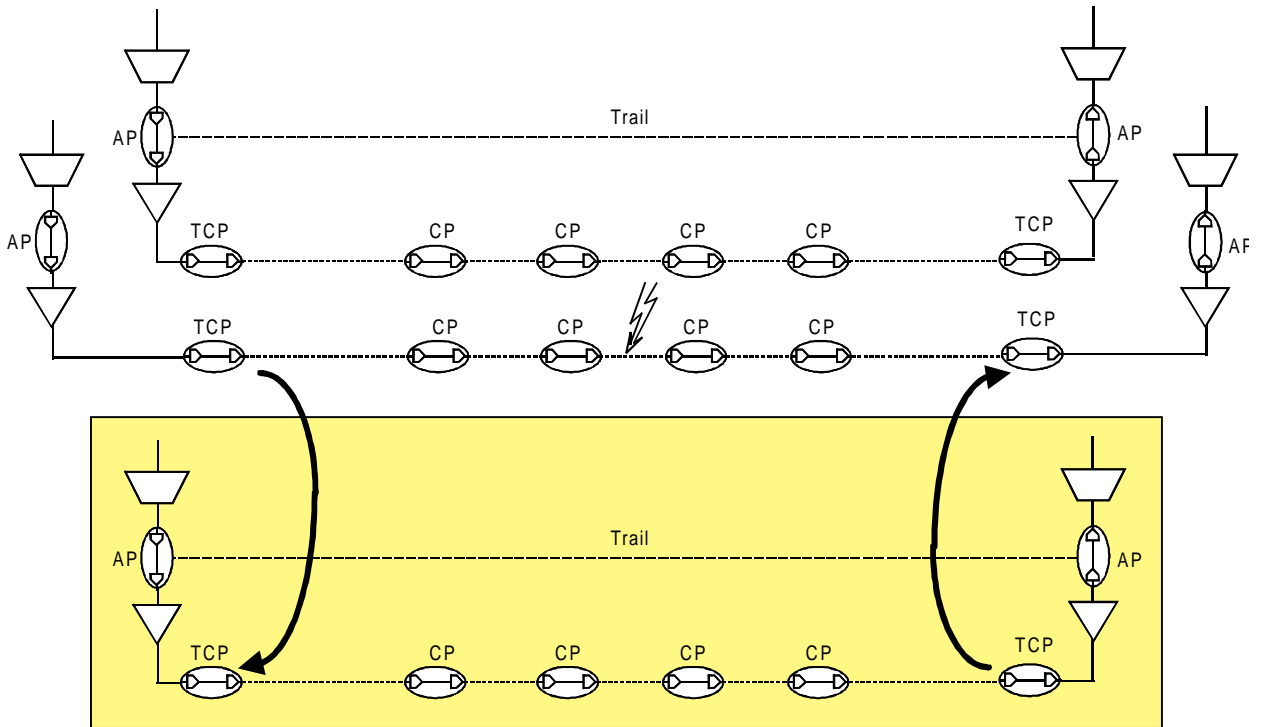

Figure 9: 1:2 protection



## Annex A: Harmonisation of vocabulary between CCITT Recommendations I.311 and G.803

### A.1 ATM network layering

CCITT Recommendation I.311	CCITT Recommendation G.803
ATM layer is subdivided in VP level and VC level	<p>An ATM transport network is made of a VC layer network and VP layer networks</p> <p>A layer network is defined by the complete set of like access points which may be associated for the purpose of transferring the characteristic information of the layer network.</p> <p>The characteristic information of a layer network has a given structure: non continuous cell flow with VCI value, any VPI value for VC layer networks, non continuous cell flow with VPI value, any VCI value for VP layer network.</p>

The VP level is in fact the complete set of VP layer networks. The layer network concept provides the possibility to define at the VP level what might be connected (inside a VP layer network) and what might not be connected (between two VP layer networks).

### A.2 Topological components inside a layer network

CCITT Recommendation G.803 [6] defines two topological components inside a layer network: the subnetwork and the link. There is no counterpart in CCITT Recommendation I.311 [2] <sup>1)</sup>. Those concepts are very important to describe a VPNC provided by two network operators and to describe related OAM flows.

### A.3 Transport entities and transport functions

CCITT Recommendation I.311	CCITT Recommendation G.803
Connection	Trail
Link	Link connection
?	Network connection
Connecting point function	Subnetwork connection, adaptation function, trail termination function
Connection end points function	Adaptation function and trail termination function

CCITT Recommendation I.311 [2] is more a vertical view (from the physical layer to the ATM layer) of the functions needed in a ATM network element. It is, therefore, related with functional blocs of an ATM network element.

CCITT Recommendation G.803 [6] is an horizontal view describing what transport functions and entities are needed inside layer network and independently of the upper and lower layers.

### A.4 Reference points

There is no counterpart in CCITT Recommendation I.311 [2] of the reference points (connection point, termination connection point and access point) used in CCITT Recommendation G.803 [6]. Reference point provide no function. It just binds transport entities and transport functions together.

<sup>1)</sup> The link as defined in CCITT Recommendation I.311[2] has a different meaning

## History

Document history	
October 1993	First Edition
March 1996	Converted into Adobe Acrobat Portable Document Format (PDF)