



TECHNICAL
BASIS for
REGULATION

TBR 42

February 1998

Source: SES

Reference: DTBR/SES-00018

ICS: 33.020

Key words: Satellite, mobile, earth station, MES, S-PCN, MSS, type approval

**Satellite Personal Communications Networks (S-PCN);
Mobile Earth Stations (MESs), including handheld earth stations,
for S-PCN in the 2,0 GHz bands under the
Mobile Satellite Service (MSS);
Terminal essential requirements**

ETSI

European Telecommunications Standards Institute

ETSI Secretariat

Postal address: F-06921 Sophia Antipolis CEDEX - FRANCE

Office address: 650 Route des Lucioles - Sophia Antipolis - Valbonne - FRANCE

X.400: c=fr, a=atlas, p=etsi, s=secretariat - **Internet:** secretariat@etsi.fr

Tel.: +33 4 92 94 42 00 - Fax: +33 4 93 65 47 16

Copyright Notification: No part may be reproduced except as authorized by written permission. The copyright and the foregoing restriction extend to reproduction in all media.

© European Telecommunications Standards Institute 1998. All rights reserved.

Contents

Foreword	7
1 Scope	9
2 Normative references	10
3 Definitions and abbreviations	10
3.1 Definitions	10
3.2 Abbreviations	11
4 General	12
4.1 Presentation of equipment for testing purposes	12
4.2 Description of equipment	12
4.3 Host-connected equipment	13
5 Unwanted emissions outside the band 1 980,1 to 2 009,9 MHz (carrier-on)	13
5.1 Justification	13
5.2 Purpose	13
5.3 Conformance requirements	13
5.4 Method of test	14
5.4.1 Peak measurement	15
5.4.2 Average measurement	15
5.5 Test requirements	15
6 Unwanted emissions within the bands 1 980,1 to 2 009,9 MHz, 1 978,1 to 1 980,1 MHz and 2 009,9 to 2 011,9 MHz (carrier-on)	16
6.1 Justification	16
6.2 Purpose	16
6.3 Conformance requirements	16
6.4 Method of test	16
6.4.1 Measurement method	17
6.5 Test requirements	17
7 Unwanted emissions in carrier-off state	18
7.1 Justification	18
7.2 Purpose	18
7.3 Conformance requirements	18
7.4 Method of test	18
7.4.1 Measurement method	19
7.5 Test requirements	19
8 MES Control and Monitoring Functions (CMF)	19
8.1 Special test equipment	19
8.2 Self-monitoring functions	19
8.2.1 Processor monitoring	19
8.2.1.1 Justification	19
8.2.1.2 Purpose	19
8.2.1.3 Conformance requirements	20
8.2.1.4 Method of test	20
8.2.2 Transmit frequency generation sub-system monitoring	20
8.2.2.1 Justification	20
8.2.2.2 Purpose	20
8.2.2.3 Conformance requirements	20
8.2.2.4 Method of test	20
8.3 Network control authorization and reception	20
8.3.1 Network control authorization	20

8.3.1.1	Justification	20
8.3.1.2	Purpose	20
8.3.1.3	Conformance requirements	21
8.3.1.4	Method of test	21
8.3.1.5	Test procedure	21
8.3.1.6	Test requirement	21
8.3.2	Network control reception	22
8.3.2.1	Transmit frequency control	22
8.3.2.1.1	Justification	22
8.3.2.1.2	Purpose	22
8.3.2.1.3	Conformance requirements	22
8.3.2.1.4	Method of test	22
8.3.2.1.5	Test procedure	22
8.3.2.1.6	Test requirement	22
8.4	Fellow radio stations in a dual-mode or multi-mode terminal	22
8.4.1	Justification	22
8.4.2	Purpose	23
8.4.3	Conformance requirements	23
8.4.4	Method of test	23
8.4.5	Test procedure	23
8.4.6	Test requirements	23
9	Equipment identity	23
9.1	Justification	23
9.2	Purpose	23
9.3	Conformance requirements	23
9.4	Method of test	23
9.5	Test procedure	24
9.6	Test requirements	24
Annex A (normative):	General test requirements	25
A.1	MES test modes	25
A.2	Special Test Equipment	25
A.2.1	STE description	25
A.2.2	Use of STE for control and monitoring functions tests	25
A.2.3	Test modulating signal	26
A.3	Laboratory Test Equipment (LTE)	26
A.4	Methods of test for MES RF emissions	27
A.5	Interpretation of the measurement results	27
A.6	Test report	27
Annex B (normative):	Environmental conditions and host connected equipment	28
B.1	General	28
B.2	Environmental requirements	28
B.2.1	Temperature	28
B.2.2	Voltage	28
B.2.3	Vibration	28
B.3	Environmental test conditions	28
B.3.1	Specification of the environmental test conditions	28
B.3.2	Tests under extreme voltage conditions	29
B.4	Testing of host-connected equipment and plug-in modules	29
B.4.1	Alternative A: combined equipment	29
B.4.2	Alternative B: use of a test jig	29

Annex C (normative):	Procedures for measurement of radiated emissions	30
C.1	General.....	30
C.1.1	Test site	30
C.1.2	Test set up for radiated emissions of the MES	30
C.1.3	Reference position of the MES	31
C.2	Measurement procedure for radiated emissions (peak)	31
C.2.1	Measurement procedure for peak radiated emissions of the MES.....	31
C.2.2	Measurement procedure for peak radiated emissions of the cabinet.....	32
C.3	Measurement procedure for radiated emissions (average)	33
C.3.1	Measurement procedure for average radiated emissions of the MES	33
C.3.2	Measurement procedure for average radiated emissions of the cabinet.....	34
Annex D (normative):	Procedures for measurement of conducted emissions.....	35
D.1	General.....	35
D.1.1	Test site	35
D.1.2	Test set-up.....	35
D.2	Measurement procedure for conducted emissions (peak).....	35
D.3	Measurement procedure for conducted emissions (average).....	36
Annex E (informative):	Explanation of nominated bandwidth.....	37
E.1	Introduction.....	37
E.2	Interpretation of Parameters $[B_n, f_c, a, b]$	37
E.3	Choice of nominated bandwidth	37
E.4	Maximum value for nominated bandwidth.....	39
Annex F (normative):	The TBR Requirements Table.....	41
Annex G (informative):	Bibliography	42
History.....		43

Blank page

Foreword

This Technical Basis for Regulation (TBR) has been produced by the Satellite Earth Stations and Systems (SES) Technical Committee of the European Telecommunications Standards Institute (ETSI).

The present document has been produced by ETSI in response to a mandate from the European Commission issued under Council Directive 83/189/EEC (as amended) laying down a procedure for the provision of information in the field of technical standards and regulations.

The present document is intended to become a Harmonized Standard, the reference of which will be published in the Official Journal of the European Communities referencing the Council Directive 93/97/EEC of 29 October 1993 supplementing Directive 91/263/EEC in respect of satellite earth station equipment ("the SES Directive").

A common technical regulation may be established by the European Commission in accordance with the Directive.

Technical specifications relevant to the SES Directive are given in annex F.

Blank page

1 Scope

This Technical Basis for Regulation (TBR) specifies those technical requirements under Article 4 of Council Directive 93/97/EEC (SES Directive), supplementing Council Directive 91/263/EEC (TTE Directive), in respect of satellite earth station equipment that apply to Mobile Earth Station (MES) equipment with both transmit and receive capabilities for operation in a Satellite - Personal Communications Network (S-PCN), in the Mobile Satellite Service (MSS) frequency bands given in table 1.

Table 1: Mobile Satellite Service (MSS) frequency bands

	MSS frequency bands
MESs transmit	1 980 to 2 010 MHz
MESs receive	2 170 to 2 200 MHz

An S-PCN MES may be a handheld, portable, vehicle-mounted, host connected, semi-fixed or fixed equipment, or may be an element in a multi-mode terminal; it may consist of a number of modules with associated connections and user interface, or may be a self contained single unit.

If the MES is an element in a multi-mode terminal, unless otherwise stated in this TBR, its requirements apply only to the S-PCN MES element of the terminal operating in the MSS frequency bands given in table 1.

The technical requirements in this TBR are applied under Articles 4.1 and 4.3 of the SES Directive referencing Article 4(e) of the TTE Directive, concerning effective use of the radio frequency spectrum, including the effective use of orbital resources and the avoidance of harmful interference between space-based and terrestrial communications systems and other technical systems. These requirements are in two major categories:

unwanted emissions limits: to protect other radio services from harmful interference generated by the MES in normal use;

MES Control and Monitoring Functions (CMF): to protect other radio services from unwanted transmissions from the MES. The CMF in each MES is capable of answering to commands from the Network Control Facilities (NCF) for its S-PCN.

NOTE: The requirements for Network Control Facilities (NCF) for S-PCN are contained in ETS 300 735 (see annex G).

There are no technical requirements in this TBR under:

- Articles 4.1 and 4.4 of the SES Directive, referencing Article 4(c) of the TTE Directive as there are no EMC requirements specific to the S-PCN MESs, nor under:
 - Article 4.1 of the SES Directive, referencing Article 4(d) of the TTE Directive;
 - Articles 4.1 and 4.5 of the SES Directive, referencing Article 4(f) of the TTE Directive;
 - Articles 4.1 and 4.6 of the SES Directive, referencing Article 4(g) of the TTE Directive;

as, for the purposes of the SES Directive and the TTE Directive, the radio interface between the MES and the S-PCN network is not regarded as a network termination point of a public telecommunications network.

An MES may be subject to additional or alternative requirements in other TBRs depending on its functionality, in particular if it supports a service which is considered a justified case for regulation of terminal equipment interworking via the public telecommunications network.

2 Normative references

This TBR incorporates, by dated or undated reference, provisions from other publications. These normative references are cited at the appropriate places in the text and the publications are listed hereafter. For dated references, subsequent amendments to, or revisions of any of these publications apply to this TBR only when incorporated in it by amendment or revision. For undated references the latest edition of the publication referred to applies.

- [1] CCITT Recommendation O.153 (1988): "Characteristics of distortion and error-rate measuring apparatus for data transmission".

3 Definitions and abbreviations

3.1 Definitions

For the purposes of this TBR, the following definitions apply:

applicant: A party seeking an approval, or to place an S-PCN MES on the European market, i.e. the manufacturer of the equipment, or his authorized representative, or an equipment supplier to the European market.

carrier-on state (allocated a channel): An MES is in this state when it is transmitting a signal in a continuous or non-continuous mode.

carrier-off state (idle mode): An MES is in this state when it is powered-on but not transmitting a signal, i.e. not in carrier-on state.

conducted measurement: A measurement of emissions from an antenna port of the MES made by direct wired connection to the port.

Equivalent Isotropically Radiated Power (EIRP): The product of transmitter power and maximum antenna gain, equivalent to an isotropic source radiating uniformly in all directions.

handheld: Indicates a PE MES which is self-contained and is small enough and light enough to be carried and used during a call with one hand.

host-connected: Indicates an MES for which connection to or integration with host equipment is necessary to offer functionality.

host equipment: Is any equipment which has a complete user functionality when not connected to the MES, and to which the MES provides additional functionality, and to which connection is necessary for the MES to offer functionality.

Installable Equipment (IE), Internally Mounted Equipment (IME) and Externally Mounted Equipment (EME): An Installable Equipment (IE) is an equipment which is intended to be installed in a vehicle. An IE may consist of one or several interconnected modules. The IE is composed of modules intended to be externally mounted as declared by the applicant, and defined as Externally Mounted Equipment (EME) and the remaining module(s) as Internally Mounted Equipment (IME).

Laboratory Test Equipment (LTE): A logical grouping that contains the standard test equipment provided by a test laboratory.

MSS band: A continuous range of frequencies allocated by the ITU to the MSS.

multi-mode: Indicates equipment that accommodates radio stations of different radio networks.

narrow-band system: A narrow band system is one in which the nominal carrier frequency spacing for MESs in the earth-to-space direction is less than 300 kHz.

network control channel: A channel by which an MES receives general control information from the NCF of its S-PCN.

NCF control message: A message, normally originating from a network, to a specified terminal or set of terminals of the network which indicates to the terminal or set of terminals that it/they should carry out some specific action or should enter or maintain some specific state. For test purposes NCF control messages may originate from Special Test Equipment (STE).

nominated bandwidth (B_n): The B_n of the Mobile Earth Station (MES) radio frequency transmission is wide enough to encompass all spectral elements of the transmission which have a level greater than the specified levels of unwanted emissions. The B_n is defined relative to the MES actual carrier frequency f_c .

B_n is the width of the frequency interval ($f_c - a$, $f_c + b$), where a and b , which shall be specified by the applicant, may vary with f_c .

The frequency interval ($f_c - a$, $f_c + b$) shall not encompass more than either:

- i) when $a = b$, 4 nominal carrier frequencies for narrow-band systems;
- ii) when $a \neq b$, 1 nominal carrier frequency for narrow-band systems, or
- iii) 1 nominal carrier frequency for wide-band systems.

The frequency interval ($f_c - a$, $f_c + b$) shall be within the operational band of the MES.

operational band: The sub-portion of the band 1 980 to 2 010 MHz which has been assigned in the earth-to-space direction to the MSS network, within which the MES is operating.

Portable Equipment (PE): A Portable Equipment (PE) is generally intended to be self-contained, free standing and portable. A PE would normally consist of a single module, but may consist of several interconnected modules.

radiated measurement: A measurement of an actual radiated field.

Special Test Equipment (STE): An equipment which allows a test laboratory to control the MES so that the tests required by this TBR can be performed.

test laboratory: A laboratory authorized by an accreditation body, which performs conformance testing in accordance with the SES and TTE directives.

test load: The test load is a substantially non-reactive, non-radiating power attenuator which is capable of safely dissipating the power from the transmitter(s).

unwanted emissions: Unwanted emissions are those falling outside the nominated bandwidth in the carrier-on state and those generated in the carrier-off state.

wide-band system: A wide-band system is one in which the nominal carrier frequency spacing for MESs in the earth-to-space direction is equal or greater than 300 kHz.

3.2 Abbreviations

For the purposes of this TBR, the following abbreviations apply:

B_n	nominated Bandwidth
CCITT	Comité Consultatif International Télégraphique et Téléphonique (now ITU-T)
CDMA	Code Division Multiple Access
CMF	Control and Monitoring Functions
dBW	decibel relative to 1 Watt
EIRP	Equivalent Isotropically Radiated Power
EMC	Electro-Magnetic Compatibility
EME	Externally Mounted Equipment
IE	Installable Equipment
IEC	International Electrotechnical Commission/Committee
IME	Internally Mounted Equipment
ITU	International Telecommunications Union
LTE	Laboratory Test Equipment
MES	Mobile Earth Station

MSS	Mobile Satellite Service
MIC	MES unique Identification Code (within its S-PCN)
NCF	Network Control Facility
PE	Portable Equipment
RF	Radio Frequency
SES	Satellite Earth Stations and Systems or, in the case of the SES Directive, Satellite Earth Station
S-PCN	Satellite Personal Communications Network
STE	Special Test Equipment
TDMA	Time Division Multiple Access
TTE	Telecommunications Terminal Equipment

4 General

4.1 Presentation of equipment for testing purposes

The applicant may provide to a test laboratory one or more preliminary or production models of the MES equipment, as appropriate, for testing for conformance against the technical requirements of this TBR.

If the MES is intended for use with an active antenna, this shall be provided as part of the MES.

If a statement of conformance with the TBR is given by the test laboratory on the basis of tests on a preliminary model, then the statement of conformance shall apply to corresponding production models only if they are identical in all technical respects with the preliminary model tested.

4.2 Description of equipment

The applicant shall provide to the test laboratory a statement which contains all of the information related to the MES and its testing environment which will enable the test laboratory to run an appropriate test suite against the MES.

This shall include:

- Self contained or host-connected;
- Single-mode or multi-mode;
- Antenna:
 - active; or
 - passive, with an antenna port available; or
 - passive, no antenna port available.

NOTE 1: If the MES has an active antenna, the antenna is regarded as an integral part of the MES.

NOTE 2: If the MES is intended for use with a passive antenna, the maximum gain of any antenna intended to be used with the equipment is to be stated.

- The method by which the equipment can be switched into its test modes.

NOTE 3: If Special Test Equipment (STE) is required see annex A, clause A.2.

- The fault conditions which cause transmission shut-down;
- The nominal, the lower extreme and the higher extreme operational voltages;
- In the case of a multi-mode MES, the other modes of operation;
- If the conducted emission measurements are to be performed:
 - The gain at the frequency of the measured spurious emission, according to the choice of the applicant.

- In an information leaflet, for each S-PCN for which the MES is designed to operate:
 - 1) the name of the S-PCN;
 - 2) the maximum value of nominated bandwidth for that S-PCN, as defined by the network operator;
 - 3) the a and b values of the nominated bandwidth for each nominal carrier frequency of the MES;
 - 4) the operating frequency range(s) of the MES;
 - 5) The frequency sub-bands and operating conditions for which the different EIRP density limits apply;
 - 6) the maximum gross data rate at which the MES is designed to operate
 - 7) the agreement of the network operator to the above information;

4.3 Host-connected equipment

For testing of equipment for which connection to, or integration with, host equipment is required to offer functionality, the applicant shall supply a statement indicating which of the test configurations detailed in clause B.4 shall be used.

5 Unwanted emissions outside the band 1 980,1 to 2 009,9 MHz (carrier-on)

5.1 Justification

This requirement is justified under SES Directive Articles 4.1 and 4.3.

5.2 Purpose

Protection of other radio services operating outside the band 1 980 to 2 010 MHz from emissions caused by S-PCN MESs operating within the band 1 980,1 to 2 009,9 MHz.

5.3 Conformance requirements

The maximum EIRP density of the unwanted emissions from the MES outside the band 1 980,1 to 2 009,9 MHz shall not exceed the limits in table 2.

In table 2, whenever a change of limit between adjacent frequency bands occurs, the lower of the two limits shall apply at the transition frequency.

Table 2: Unwanted emissions outside the band 1 980,1 to 2 009,9 MHz

Frequency (MHz)	Carrier - on		
	EIRP (dBW)	Measurement bandwidth	Measurement method
0,1 - 30	-66	10 kHz	Peak hold
30 - 1 000	-66	100 kHz	Peak hold
1 000 - 1 559	-60	3 MHz	Average
1 559 - 1 626,5	-70	1 MHz	Average (over 20 ms)
1 626,5 - 1 950	-60	3 MHz	Average
1 950 - 1 960	-60	1 MHz	Average
1 960 - 1 970	-60	300 kHz	Average
1 970 - 1 975	-60	100 kHz	Average
1 975 - 1 978,1	-60	30 kHz	Average
1 978,1 - 1 980,1	The levels in table 3 for the frequency offset 0 to 2 MHz shall apply from 1 980,1 to 1 978,1 MHz		
1 980,1 - 2 009,9	Not applicable	Not applicable	Not applicable
2 009,9 - 2 011,9	The levels in table 3 for the frequency offset 0 to 2 MHz shall apply from 2 009,9 to 2 011,9 MHz		
2 011,9 - 2 015	-60	30 kHz	Average
2 015 - 2 020	-60	100 kHz	Average
2 020 - 2 030	-60	300 kHz	Average
2 030 - 2 040	-60	1 MHz	Average
2 040 - 2 600	-60	3 MHz	Average
2 600 - 12 750	-60	3 MHz	Peak hold

The conformance requirements apply for the full range of environmental conditions corresponding to the type of equipment as specified in clause B.2.

5.4 Method of test

This test shall be carried out for the minimum and for the maximum MES transmit frequencies for which the MES is designed to operate, as specified by the applicant.

The environmental test conditions are given in clause B.3.

For each test, the MES shall be set to transmit (carrier-on) on one of the specified transmitting frequencies to be tested at its maximum power for that transmit frequency, by means of the STE or by another test facility provided by the applicant.

If there is a handover function in the MES (to allow change of frequency channel during a call), this function shall be disabled.

The transmitted carrier shall be modulated by a test signal at maximum rate as specified in subclause A.2.3.

In the test equipment, the spectrum analyzer noise floor shall be at least 6 dB below the appropriate limits given in table 2.

The measurements are performed with the radiated or with the conducted method according to the cases defined in clause A.4.

For measurements of radiated unwanted emissions, annex C applies.

For measurements of conducted unwanted emissions, annex D applies.

5.4.1 Peak measurement

In the case of peak measurement, the spectrum analyzer shall be set in sweep mode and shall be operated under the following conditions:

frequency sweep:	as required for frequency range to be assessed;
resolution bandwidth:	measurement bandwidth specified in table 2;
display bandwidth:	at least three times the measurement bandwidth;
averaging:	no;
peak hold:	yes.

The sweep time shall be the shortest possible time consistent with proper calibration and ease of operation.

The spectrum analyzer shall be stepped over the frequency ranges specified in table 2 for peak measurement.

5.4.2 Average measurement

In the case of average measurement, the spectrum analyzer shall be set in sweep mode and shall be operated under the following conditions:

frequency sweep:	as required for frequency range to be assessed;
resolution bandwidth:	measurement bandwidth specified in table 2;
display bandwidth:	equal to the measurement bandwidth;
averaging:	yes;
peak hold:	no.

The measurement time shall be such that the difference of the measured levels, averaged over subsequent measurement samples, is less than 1 dB, or a measurement time of 100 ms may be used if the measured values comply with the applicable limits.

For a MES operating in a non-continuous carrier mode, the measurement shall be performed over the active part of the transmitted bursts. The total sample time used for measurement shall be not less than 40 % of the duration of the active part of the transmitted burst. The measurement shall be made over the random part of the burst, excluding any preambles or synchronisation sequences.

The spectrum analyzer shall be stepped over the frequency ranges specified in table 2 for average measurement.

5.5 Test requirements

For measurements of radiated unwanted emissions of the MES, the measured values shall in no case exceed the limits given in table 2.

For measurements of conducted unwanted emissions of the MES, the measured values plus the maximum antenna gain shall in no case exceed the limits given in table 2.

6 Unwanted emissions within the bands 1 980,1 to 2 009,9 MHz, 1 978,1 to 1 980,1 MHz and 2 009,9 to 2 011,9 MHz (carrier-on)

6.1 Justification

This requirement is justified under SES Directive Articles 4.1 and 4.3.

6.2 Purpose

Protection of radio services and systems operating within the frequency band 1 978,1 to 2 011,9 MHz from unwanted emissions caused by S-PCN MESs operating in the band 1 980,1 to 2 009,9 MHz.

6.3 Conformance requirements

The maximum EIRP spectral density of the unwanted emissions from the MES within the band 1 978,1 to 2 011,9 MHz shall not exceed the limits in tables 3 or 4, as applicable.

In the tables 3 and 4, whenever a change of limit between adjacent frequency bands occurs, the lower of the two limits shall apply at the transition frequency.

When conflicts between multiple requirements exist, the more stringent requirement applies.

Table 3: Maximum unwanted emissions within the bands 1 980,1 to 2 009,9 MHz from a TDMA carrier, and maximum unwanted emissions within the bands 1 978,1 to 1 980,1 and 2 009,9 to 2 011,9 MHz from any carrier

Frequency offset (kHz) (note 1)	Carrier - on		
	EIRP (dBW)	Measurement bandwidth (kHz)	Measurement method
0 to 166	$0 - (\text{offset} \times 55/166)$	3 kHz	Average
166 to 575	-55	3 kHz	Average
575 to 1 175	-60	3 kHz	Average
1 175 to 1 525	$-50 - ((\text{offset} - 1 175) \times 5/350)$	30 kHz (note 2)	Average
1 525 to 32 000	-55	30 kHz (note 2)	Average

NOTE 1: Frequency offset is determined from edge of nominated bandwidth.
NOTE 2: The measurement bandwidth used may be 3 kHz if the unwanted EIRP limits are reduced correspondingly.

Table 4: Maximum unwanted emissions within the band 1 980,1 to 2 009,9 MHz from a CDMA carrier

Frequency offset (kHz) (note)	Carrier - on		
	EIRP (dBW)	Measurement bandwidth (kHz)	Measurement method
0 to 160	-35	30	Average
160 to 2 300	$-35 - ((\text{offset} - 160) \times 21/ 2 140)$	30	Average
2 300 to 32 000	-56	30	Average

NOTE: Frequency offset is determined from the edge of nominated bandwidth.

The conformance requirements apply for the full range of environmental conditions corresponding to the type of equipment as specified in clause B.2.

6.4 Method of test

This test shall be carried out for the minimum and for the maximum MES transmit frequency for which the MES is designed to operate, as specified by the applicant.

The transmit frequencies used for the test shall be entered in the test report.

The environmental test conditions are given in clause B.3.

For each test, the MES shall be set to transmit (carrier-on) on one of the specified transmit frequencies to be tested, at its maximum power for that transmit frequency, by means of the STE or by another test facility provided by the applicant.

If there is a handover function in the MES (to allow change of frequency channel during a call), this function shall be disabled.

The transmitted carrier shall be modulated by a test signal at maximum rate as specified in subclause A.2.3.

In the test equipment, the spectrum analyzer noise floor shall be at least 6 dB below the appropriate limits given in tables 3 or 4, as applicable.

The measurements are performed with the radiated or with the conducted method according to the cases defined in subclause A.4.

For measurements of radiated unwanted emissions, annex C applies.

For measurements of conducted unwanted emissions, annex D applies.

6.4.1 Measurement method

The spectrum analyzer shall be set in sweep mode and shall be operated under the following conditions:

frequency sweep:	as required for frequency range to be assessed;
resolution bandwidth:	measurement bandwidth specified in tables 3 or 4, as applicable;
display bandwidth:	equal to the measurement bandwidth;
averaging:	yes;
peak hold:	no.

The measurement time should be such that the difference of the measured levels, averaged over subsequent measurement samples, is less than 1 dB, or a measurement time of 100 ms may be used if the measured values comply with the applicable limits.

For a MES operating in a non-continuous carrier mode, the measurement shall be performed over the active part of the transmitted bursts. The total sample time used for measurement shall be not less than 40 % of the duration of the active part of the transmitted burst. The measurement shall be made over the random part of the burst, excluding any preambles or synchronisation sequences.

For each of the transmit frequencies to be used for the test, measurements shall be made over the frequency ranges from 1 978,1 MHz to $f_c - a$ and from $f_c + b$ to 2 011,9 MHz, $f_c - a$ being the lower boundary frequency of the nominated bandwidth for the transmit frequency being tested, and $f_c + b$ being the upper boundary frequency of the nominated bandwidth for the transmit frequency being tested.

6.5 Test requirements

For measurements of radiated unwanted emissions of the MES, the measured values shall in no case exceed the limits given in tables 3 or 4, as applicable, over the frequency range 1 978,1 to 2 011,9 MHz.

For measurements of conducted unwanted emissions, the measured values plus the maximum antenna gain, shall in no case exceed the limits given in tables 3 or 4, as applicable, over the frequency range 1 978,1 to 2 011,9 MHz.

7 Unwanted emissions in carrier-off state

7.1 Justification

This requirement is justified under SES Directive Articles 4.1 and 4.3.

7.2 Purpose

Protection of other radio services and systems from unwanted emissions caused by MESs in the carrier-off state.

7.3 Conformance requirements

The maximum EIRP of the unwanted emissions from the MESs in the carrier-off state shall not exceed the limits in table 5.

In table 5, whenever a change of limit between adjacent frequency bands occurs, the lower of the two limits shall apply at the transition frequency.

Table 5: Maximum EIRP of the unwanted emissions in the carrier-off state

Frequency (MHz)	EIRP (dBW)	Measurement bandwidth	Measurement method
0,1 - 30	-87	10 kHz	peak hold
30 - 1 000	-87	100 kHz	peak hold
1 000 - 12 750	-77	100 kHz	peak hold

The conformance requirements apply for the full range of environmental conditions corresponding to the type of equipment as specified in clause B.2.

7.4 Method of test

The MES shall be switched-on and set in a non-transmitting (carrier-off) mode.

If there is a periodic automatic transmission of bursts (e.g. for location updating), the STE shall provide a means to inhibit it, or to trigger the measurement in order to analyse only the non-transmitting periods.

The environmental test conditions are given in clause B.3.

In the test equipment, the spectrum analyzer noise floor shall be at least 6 dB below the appropriate limits given in table 5.

The measurements are performed with the radiated or with the conducted method according to the cases defined in subclause A.4.

For measurements of radiated unwanted emissions, annex C applies.

For measurements of conducted unwanted emissions, annex D applies.

7.4.1 Measurement method

The spectrum analyzer shall be set in sweep mode and shall be operated under the following conditions:

frequency sweep:	as required for frequency range to be assessed;
resolution bandwidth:	measurement bandwidth specified in table 5;
display bandwidth:	at least 3 times the measurement bandwidth;
averaging:	no;
peak hold:	yes.

The sweep time shall be the shortest possible time consistent with proper calibration and ease of operation.

The spectrum analyzer shall be stepped over the frequency ranges specified.

7.5 Test requirements

For measurements of radiated unwanted emissions of the MES, the measured values shall in no case exceed the limits given in table 5.

For measurements of conducted unwanted emissions of the MES, the measured values plus the maximum antenna gain shall in no case exceed the limits given in table 5.

8 MES Control and Monitoring Functions (CMF)

8.1 Special test equipment

Many of the tests in this clause require that the MES be situated in an environment where receipt of a network control channel and of NCF commands is controlled by the test laboratory. This will require the provision by the applicant of Special Test Equipment (see clause A.2). This STE shall provide the means to generate and to communicate to the MES, either radiated via its antenna or conducted via direct connection to its antenna port, the network control channel and the required NCF commands, under the control of the test laboratory. The STE shall also provide means for the test laboratory to interface its test equipment with the MES for the purpose of monitoring the MES responses.

8.2 Self-monitoring functions

8.2.1 Processor monitoring

8.2.1.1 Justification

This requirement is justified under SES Directive, Articles 4.1 and 4.3.

8.2.1.2 Purpose

Protection of radio services and systems from uncontrolled RF transmissions from the MES.

8.2.1.3 Conformance requirements

The MES shall incorporate a processor monitoring function for each of its processors involved in the manipulation of traffic and in control and monitoring functions.

The processor monitoring function shall detect failure of the processor hardware and software.

Not later than 1 s after any detectable fault condition occurs, the transmissions shall be suppressed (carrier-off) until the processor monitoring function has determined that all fault conditions have been cleared.

The fault conditions which cause transmission shutdown shall be specified by the applicant and declared by the applicant.

The conformance requirements apply for the environmental conditions as specified in clause B.2.

8.2.1.4 Method of test

As it is considered impracticable to artificially induce processor faults in an MES, no test is given for the processor monitoring function.

8.2.2 Transmit frequency generation sub-system monitoring

8.2.2.1 Justification

This requirement is justified under SES Directive, Articles 4.1 and 4.3.

8.2.2.2 Purpose

Protection of radio services and systems from uncontrolled RF transmissions from the MES.

8.2.2.3 Conformance requirements

The MES shall incorporate a transmit frequency generation sub-system monitoring function.

Not later than 5 s after any detectable failure of the transmit frequency generation sub-system occurs, the transmissions shall be suppressed (carrier-off) until the transmit frequency generation sub-system monitoring function has determined that all fault conditions have been cleared.

The fault conditions which cause transmission shutdown shall be specified by the applicant and declared by the applicant.

The conformance requirements apply for the environmental conditions as specified in clause B.2.

8.2.2.4 Method of test

As it is considered impracticable to artificially induce transmit frequency generation sub-system faults in an MES, no test is given for the transmit frequency generation sub-system monitoring function.

8.3 Network control authorization and reception

8.3.1 Network control authorization

8.3.1.1 Justification

This requirement is justified under SES Directive, Articles 4.1 and 4.3.

8.3.1.2 Purpose

Protection of radio services and systems from uncontrolled RF transmissions from the MES.

8.3.1.3 Conformance requirements

During POWER-ON no transmissions shall occur from the MES.

Following POWER-ON the MES shall enter a controlled, non-transmitting (carrier-off) state. This state shall be maintained whilst the MES is not synchronized with the appropriate network control channel(s).

Without synchronizing to the appropriate network control channel(s), it shall not be possible to initiate carrier-on state.

Within 30 s of having lost the appropriate network control channel(s) the MES shall suppress transmissions (carrier-off).

The conformance requirements apply for the environmental conditions as specified in clause B.2.

8.3.1.4 Method of test

The MES shall be cycled through its power-on and power-off states. Attempts shall be made to initiate calls using normal user operational procedures. The transmitting state of the MES shall be monitored to ensure compliance with the test requirements.

The environmental test conditions are given in clause B.3.

8.3.1.5 Test procedure

The MES shall be situated in an environment where receipt of the appropriate network control channel(s) is controlled by the test laboratory.

- a) The MES shall be in a power-off state, situated such that it is not in receipt of a network control channel.
- b) The MES shall be powered-on.
- c) An attempt shall be made, using normal user operational procedures, to initiate a call.
- d) A network control channel shall be activated and a call shall be initiated using normal user operational procedures.
- e) The network control channel shall then be deactivated.
- f) An attempt shall be made, using normal user operational procedures, to initiate a call.
- g) The network control channel shall be reactivated and a call shall be initiated using normal user operational procedures.

Throughout this procedure, the transmission state of the MES shall be monitored.

8.3.1.6 Test requirement

During and after test procedure step a), the MES shall be in power-off state.

During and after test procedure step b), no transmissions shall occur (carrier-off).

During and after test procedure step c), no transmissions shall occur (carrier-off).

After test procedure step d), the MES shall be transmitting (carrier-on).

Within 30 seconds of test procedure step e), MES transmissions shall cease (carrier-off).

During and after test procedure step f), no transmissions shall occur (carrier-off).

After test procedure step g), the MES shall be transmitting (carrier-on).

8.3.2 Network control reception

8.3.2.1 Transmit frequency control

8.3.2.1.1 Justification

This requirement is justified under SES Directive, Articles 4.1 and 4.3.

8.3.2.1.2 Purpose

Protection of radio services and systems from uncontrolled RF transmissions from the MES.

8.3.2.1.3 Conformance requirements

The MES shall set the carrier frequency of its transmission according to the command of the NCF. The carrier frequency has to be controlled such, that the entire nominated bandwidth of the terminal falls completely within the operational frequency band(s) specified by the applicant and declared by the applicant.

The conformance requirements apply for the environmental conditions as specified in clause B.2.

8.3.2.1.4 Method of test

The nominated bandwidth of the MES shall be monitored relative to the carrier frequency commanded, and relative to the operational frequency bands for the MES specified by the applicant.

The environmental test conditions are given in clause B.3.

8.3.2.1.5 Test procedure

This test shall be carried out at least twice, once for the minimum and once for the maximum MES transmit frequency for which the MES is designed to operate, as specified by the applicant.

Where available, two additional transmit frequencies shall also be tested. These frequencies shall be equally spaced between the minimum and maximum frequencies. The commanded transmit frequencies used for the test shall be entered in the test report.

The MES shall be situated in an environment where receipt of a network control channel and of NCF commands is controlled by the test laboratory.

- a) A network control channel shall be activated and the MES powered-on.
- b) An appropriate NCF control message shall be sent, commanding the MES to set its carrier frequency to one of the transmit frequencies to be tested.
- c) The test shall be repeated for the other transmit frequencies to be tested.

The carrier mask for the transmit frequency under test shall be monitored on a spectrum analyzer, using the procedures given in subclause 6.4.

8.3.2.1.6 Test requirement

The MES shall set the centre frequency of its transmission according to the NCF command.

The entire nominated bandwidth for each transmit frequency tested shall be contained completely within the operational frequency band(s) specified by the applicant.

8.4 Fellow radio stations in a dual-mode or multi-mode terminal

8.4.1 Justification

This requirement is justified under SES Directive, Articles 4.1 and 4.3.

8.4.2 Purpose

Protection of radio services and systems from uncontrolled RF transmissions from the MES.

8.4.3 Conformance requirements

Any fellow radio station in a multi-mode MES shall not transmit without reception of a network control channel for the system for which it is designed.

The conformance requirements apply for the environmental conditions as specified for the fellow radio station.

8.4.4 Method of test

The MES shall be placed in a suitable environment which isolates the MES from the networks of its fellow modes. It shall be verified that no transmissions are made from that mode.

8.4.5 Test procedure

The MES shall be placed in an environment where the receipt of network control channel(s) of supporting networks of the fellow modes is prevented. For each fellow mode radio station, an attempt shall be made, using normal user operational procedures, to initiate a call. Throughout this procedure, the transmission state of the MES shall be monitored.

8.4.6 Test requirements

Throughout the test procedure, no transmission shall occur.

9 Equipment identity

9.1 Justification

This requirement is justified under SES Directive Articles 4.1 and 4.3.

9.2 Purpose

Protection of radio services and systems from uncontrolled RF transmissions from the MES.

9.3 Conformance requirements

Each MES shall have a unique MES Identification Code (MIC) within its S-PCN.

It shall not be possible for the user to alter the MIC using any normally accessible procedure.

The MES shall be capable of transmitting its identification code upon reception of an appropriate NCF command addressed to it.

The conformance requirements apply for the environmental conditions as specified in clause B.2.

9.4 Method of test

It is impracticable to test that each MES has a unique MES Identification Code (MIC) within its S-PCN, and that it is not possible for the user to alter the MIC using any normally accessible procedure. Consequently, no tests are given for these requirements.

The transmissions of the MES in response to an NCF command to send its identification code shall be monitored and the identification code received shall be verified.

The environmental test conditions are given in clause B.3.

9.5 Test procedure

The MES shall be situated in an environment where receipt of a network control channel and of NCF commands is controlled by the test laboratory.

- a) A network control channel shall be activated and the MES powered-on.
- b) An appropriate NCF control message shall be sent, commanding the MES to transmit its identification code.
- c) The message sent by the MES shall be analysed.

9.6 Test requirements

The MES identification code in the message sent in step c) shall be verified against that supplied by the applicant for the MES.

Annex A (normative): General test requirements

A.1 MES test modes

The MES is required to be placed in a number of different test modes in order for the various tests specified within this TBR to be carried out:

- 1) power-off;
- 2) power-on (applies to all the following test modes);
- 3) carrier-off;
- 4) carrier-on, maximum transmit power, in a specified channel in an operational band, modulated with the test modulating signal;
- 5) carrier-on, maximum transmit power, in a specified channel in an operational band, set by NCF command, modulated with the test modulating signal (Note: if this is available for all tests (4) is not required separately);
- 6) carrier-on (detectable).

The MES may be placed into test modes 4 and 5 either by means of a special facility existing internally in the MES, or by means of a Special Test Equipment (STE).

If the MES has been modified by the applicant for these tests, then full documentation showing such modification(s) shall be provided to demonstrate that the modification(s) will not cause the test results to deviate from normal operational performance.

A.2 Special Test Equipment

A.2.1 STE description

The STE shall provide the necessary facilities for tests which require that the MES be operated in its normal operating manner, situated in an environment where receipt of a network control channel and of NCF commands is under the control of the test laboratory.

The STE shall also provide means for the test laboratory to interface its test equipment with the MES for the purpose of monitoring the MES responses.

For other tests, where the required test mode cannot be, or is not, provided by a special test facility within the MES, then STE shall also provide the facility to put the MES into these required test modes.

A.2.2 Use of STE for control and monitoring functions tests

The test arrangement shall be as shown in figure A.1 for radiated and conducted measurements.

This test arrangement assumes that the STE is responsible for simulating for the MES the NCF commands or network control channel in the same way as they are received by the MES in normal operating mode. The response received by the STE from the MES shall be routed to the LTE without modification that would significantly affect the measurement.

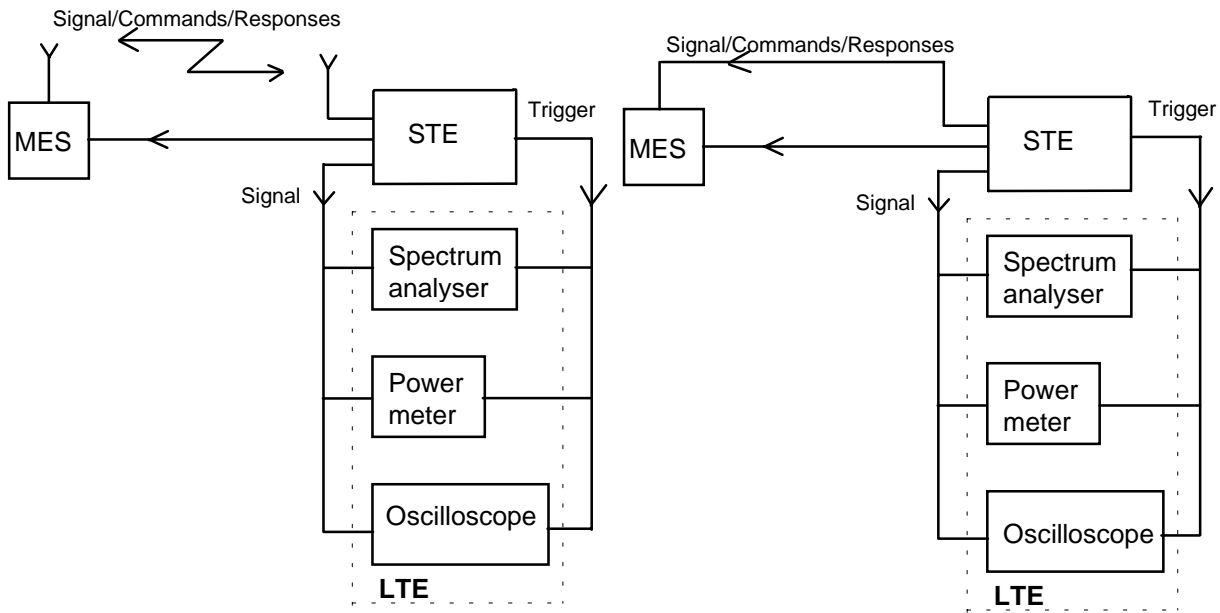

Radiated test

Conducted test

Figure A.1: General test arrangement for control and monitoring tests

The dual trace storage oscilloscope, or other suitable method, may be used to monitor the response of the MES to the simulated events by measuring the time difference between the event or command reception, and the compliance with that event.

The power meter and spectrum analyzer shall be used to monitor the MES output signal during all the test procedure.

A.2.3 Test modulating signal

The test modulating signal is a baseband signal which modulates the carrier of the MES and is dependent upon the type of equipment under test. It is a signal representing a pseudo-random bit sequence of at least 511 bits in accordance with CCITT Recommendation O.153 [1]. This sequence shall be continuously repeated and shall be at the maximum bit rate declared by the applicant at which the MES is able to operate.

If not internally generated by the MES, this test modulating signal shall be provided by the STE.

A.3 Laboratory Test Equipment (LTE)

The Laboratory Test Equipment (LTE) is a logical grouping that contains the measurement equipment provided by the test laboratory.

It shall be verified that the responses of the LTE, including any test antenna, to a constant amplitude sine wave signal remain within ± 1 dB of calibration across the frequency range of interest.

The maximum values of measurement uncertainty for the LTE associated with each measurement parameter given in table A.1 for a 95 % confidence level, shall apply as appropriate to the test cases described in this TBR.

Table A.1: Measurement uncertainties

Measured parameter	Measurement uncertainty
Radio Frequency above 1 MHz	± 1 part in 10^7
EIRP density within the operational band	$\pm 0,75$ dB
Unwanted radiated emissions	± 6 dB
Unwanted conducted emissions	± 4 dB

A.4 Methods of test for MES RF emissions

Measurements shall be performed according to the equipment type:

Table A.2: Options for testing

Equipment with passive antenna port available (external, internal or temporary)	Radiated from cabinet from 30 MHz to 4 GHz (passive antenna port connected to a dummy load), and conducted from the passive antenna port, from 100 kHz to 12,75 GHz
Equipment with no passive antenna port available	Radiated from complete MES, including its antenna, from 30 MHz to 12,75 GHz

The methods of measurement for radiated emissions are described in annex C.

The methods of measurement for conducted emissions are described in annex D.

A.5 Interpretation of the measurement results

The interpretation of the results for the measurements described in this TBR shall be as follows:

- a) the measured value related to the corresponding limit shall be used to decide whether an equipment meets the minimum requirements of the standard;
- b) the actual measurement uncertainty of the test laboratory carrying out the measurement, for each particular measurement, shall be included in the test report;
- c) the values of the actual measurement uncertainty shall be, for each measurement, equal to or lower than the figures in clause A.3.

A.6 Test report

All results of the tests performed shall be recorded in a test report.

For each test, the test report shall also include the test conditions (status of the MES, frequency of operation), the measurement uncertainties and the environmental test conditions.

Annex B (normative): Environmental conditions and host connected equipment

B.1 General

This normative annex specifies the environmental conditions under which the relevant requirements of this TBR shall be fulfilled.

B.2 Environmental requirements

B.2.1 Temperature

The MES shall fulfil all the requirements in the full temperature ranges of:

-10°C to +55 C;

(taken from IEC publications 68-2-1 and 68-2-2; see annex G).

B.2.2 Voltage

The applicant shall declare the nominal, lower and the higher extreme voltages.

The MES shall fulfil all the requirements in the full voltage range between the extreme voltages.

B.2.3 Vibration

The MES shall fulfil all the requirements when vibrated at the frequency/amplitudes given in table B.1.

Table B.1: Vibration characteristics

Frequency range	ASD (Acceleration Spectral Density) random vibration
5 Hz to 20 Hz	0,96 m ² /s ³ (+ 0/-5 %)
20 Hz to 500 Hz	0,96 m ² /s ³ (+ 0/-5 %) at 20 Hz, thereafter -3 dB/Octave (+0 /-5 %) (taken from IEC Publication 68-2-36)

B.3 Environmental test conditions

B.3.1 Specification of the environmental test conditions

The tests in clauses 5, 6 and 7 shall be performed under the conditions given in table B.2.

Table B.2: Environmental test conditions

Equipment Category	Temperature	Voltage
handheld	Normal	Normal condition voltage (± 1 %)
other than handheld	Normal	Higher extreme voltage (+0/-2 %)
other than handheld	Normal	Lower extreme voltage (-0/+2 %)

Normal temperature shall be between +15°C and +35°C.

All other tests shall be performed under normal conditions for temperature and voltage, and without vibration.

B.3.2 Tests under extreme voltage conditions

During tests under extreme voltage conditions, the power source of the equipment shall be replaced by a test power source, capable of producing extreme test voltages as specified in subclause B.3.1. The internal impedance of the test power source shall be low enough for its effect on the test results to be negligible. For the test purposes, the voltage of the power source shall be measured at the input terminals of the equipment.

If the equipment is provided with a permanently connected power cable, the test voltage shall be measured at the point of connection of the power cable to the equipment.

In equipment with incorporated batteries, the test power source shall be applied as close to the battery terminals as is practical. In each case connections shall be made readily available by the applicant.

During tests, the power source voltages shall be maintained within a tolerance of $\pm 3\%$ relative to the voltage at the beginning of each test.

B.4 Testing of host-connected equipment and plug-in modules

For equipment for which connection to or integration with host equipment is required to offer functionality, two alternative approaches are permitted. The applicant shall declare which alternative shall be used.

B.4.1 Alternative A: combined equipment

Under alternative A, a combination of MES and a specific type of host equipment shall be used for testing according to this TBR.

Where more than one such combination is intended, testing shall not be repeated for combinations of MES and other host equipment where the latter are substantially similar, in particular such that the host models are unlikely to significantly influence the emissions of the MES.

Where more than one such combination is intended and host equipment are not substantially similar, one combination shall be tested against the full set of requirements of this TBR; other combinations shall be tested separately for radiated emissions only.

B.4.2 Alternative B: use of a test jig

Under alternative B, where the MES is intended for use with a variety of host equipment, the applicant shall supply a suitable test jig that is representative of the range of host equipment in which the MES may be used. In particular, the test jig shall be designed such that any alteration of the MES's emissions is minimized. The test jig shall allow the MES part to be powered and stimulated in a way similar to the way it would be powered and stimulated when connected to or inserted into the host equipment.

The MES shall be tested against the full set of requirements of this TBR.

Annex C (normative): Procedures for measurement of radiated emissions

C.1 General

This annex contains methods for tests involving the measurement of a radiated field. This field may be radiated by an antenna and/or by the cabinet of the equipment itself.

It is recognized that for some parameters, alternative test methods may exist. It is the responsibility of the test laboratory to ensure that any alternative test method used yields results identical to those described in this TBR.

C.1.1 Test site

The standard test site shall be a calibrated open air test site, whose dimensions are appropriate to the frequency range of measurements.

All radiated measurement tests shall be conducted in such a way as to ensure that there is no interference to operational satellite and terrestrial systems. In some cases operating on a test site may produce electromagnetic perturbation or, conversely, external radiation may disturb the measurement. For these reasons, and also in order to reduce the space required, or to perform tests under extreme environmental conditions, other arrangements may be used, such as:

- anechoic chamber;
- indoor test site.

In addition, it shall be verified that the test site shall be suitable with respect to ambient noise which shall be at least 6 dB lower than the lowest specification value being measured.

The methods of measurement described in this annex are based on an open air test site. If an anechoic chamber or an indoor test site are used, some changes may apply to the method of measurement. For each radiated measurement, the nature and the dimensions of the test arrangement used shall be recorded in the test report.

C.1.2 Test set up for radiated emissions of the MES

The tests shall be carried out with the MES at the specified environmental conditions and for the specified power supply voltages.

For IE, EME and IME it shall be installed with a separation of approximately 0,5 m. Between the two equipment, the maximum length connection cable specified by the applicant shall be installed. The height of the cable shall be between 0,5 and 1 m. The cable shall be maintained in that position by non-metallic means. The EME shall be set, in its normal operating configuration on a non-conducting support at a height between 0,5 and 1 m. The IME shall be set on a non-conducting support at a height between 0,5 and 1 m. Any associated equipment, if required for normal operation of the MES, shall be placed next to, and at the same height as the IME.

For PE, the equipment shall be arranged in its normal operating configuration as recommended by the applicant on a non-metallic table at a height between 0,5 and 1 m.

The MES under test shall be placed on the support in its standard position and shall be switched-on.

Each antenna (MES antenna and test antenna) shall be positioned to be outside the near field of the other antenna.

The spectrum analyzer noise floor shall be at least 6 dB below the minimum value to be measured.

C.1.3 Reference position of the MES

During radiated measurements, the MES is required to be oriented specifically in relation to the test antenna connected to the LTE. This position is called the reference position and is determined as follows:

- The MES shall be placed in a mode whereby it is transmitting.
- The MES shall be rotated in both horizontal and vertical planes in order to locate the direction of maximum field strength that is detected by the test antenna. This orientation shall be called the reference position.

C.2 Measurement procedure for radiated emissions (peak)

C.2.1 Measurement procedure for peak radiated emissions of the MES

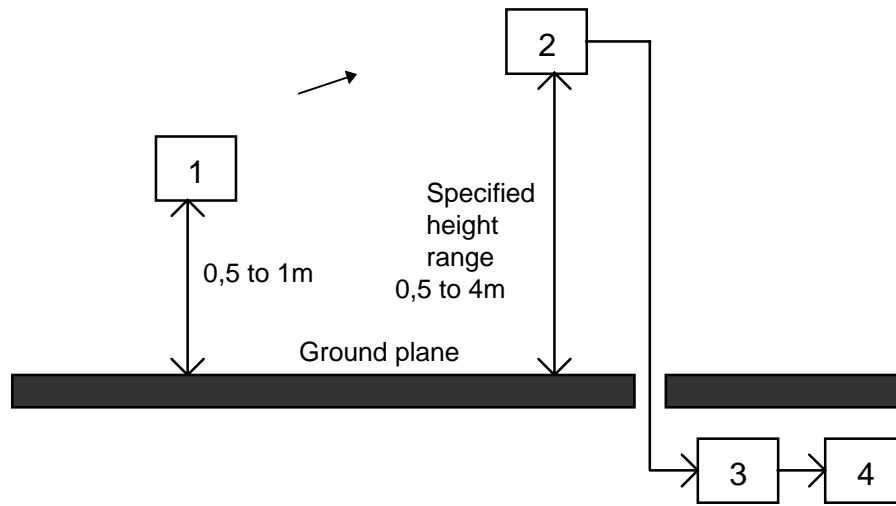

- 1) MES under test (with antenna);
- 2) Test antenna;
- 3) Input filter (if necessary);
- 4) Spectrum analyzer.

Figure C.1: Measurement arrangement No. 1

Measurement arrangement No. 1 of figure C.1 shall be used.

- a) For each measurement bandwidth, the following actions shall be performed:

The MES shall be placed in the reference position as described in subclause C.1.3.

The test antenna shall have the same polarization as the MES and connected to a spectrum analyzer, eventually through a suitable entry filter to avoid overloading of the spectrum analyzer. Precautions may be required to ensure that the filter does not attenuate the harmonics of the carrier.

The test antenna and the entry filter shall be suitable for the measured frequency band, and replaced by other each time it will be necessary.

The spectrum analyzer shall be tuned to the measurement bandwidth to analyse.

The resolution bandwidth of the spectrum analyzer shall be set to a suitable value to correctly perform the measurement, and the peak hold function shall be activated. The video bandwidth shall be set to at least 3 times the resolution bandwidth.

- b) Only the discrete signals having a level equal or greater than 6 dB below the specified limit shall be precisely measured.

The test antenna shall be raised or lowered through the specified height range to look for the maximum signal on the spectrum analyzer (this may not be necessary if the test site is an anechoic chamber or an in-door test site).

The maximum measured value shall be recorded.

- c) The procedure is repeated from a) to b) with the other measurement bandwidths to cover all the frequency range to be analysed.
- d) In the case where the test site has been calibrated before, the absolute measurement is sufficient to determine the actual value of EIRP of the radiated emissions. The precise knowledge of distance between the MES and the test antenna, and the characteristics of the test antenna and the input filter allow the determination of the EIRP radiated by the MES.
- e) In the case where the test site cannot be calibrated, a relative measurement can be done according to the following procedure:

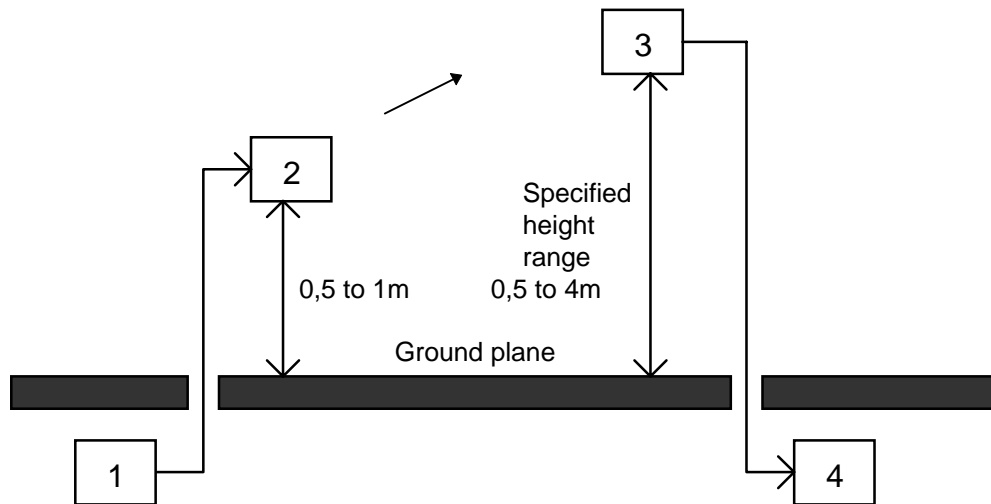

- 1) Sinusoidal RF signal generator;
- 2) Substitution antenna;
- 3) Test antenna;
- 4) Spectrum analyzer.

Figure C.2: Measurement arrangement No. 2

Using measurement arrangement No. 2 of figure C.2, a substitution antenna shall replace the MES in the same position where was the MES antenna. It shall be connected to the signal generator.

- f) The signal generator shall be tuned to each frequency at which an emission has been detected in the case of unwanted emissions measurement, or to the frequency at the middle of each measurement bandwidth in the case of EIRP density measurement, The substitution antenna shall be suitable for this frequency. The spectrum analyzer shall be tuned to the measurement bandwidth to analyse and put in the same conditions as for the measurement with the MES, with the peak hold function activated.

The level of the signal generator shall be adjusted to give the same signal level on the spectrum analyzer as in b).

The output level of the signal generator shall be recorded. This value, after corrections due to the gain of the substitution antenna and the cable loss between the signal generator and the substitution antenna, is the radiated emission level of the MES.

- g) The f) procedure is repeated with the other measurement bandwidths to cover the whole frequency range to be analysed.
- h) a) to g) shall be repeated with test antennas of the opposite polarization for the unwanted emission measurements.

C.2.2 Measurement procedure for peak radiated emissions of the cabinet

This method of measurement applies to transmitters having an antenna socket and has to be performed in addition to conducted measurements of the MES in the case of unwanted emissions.

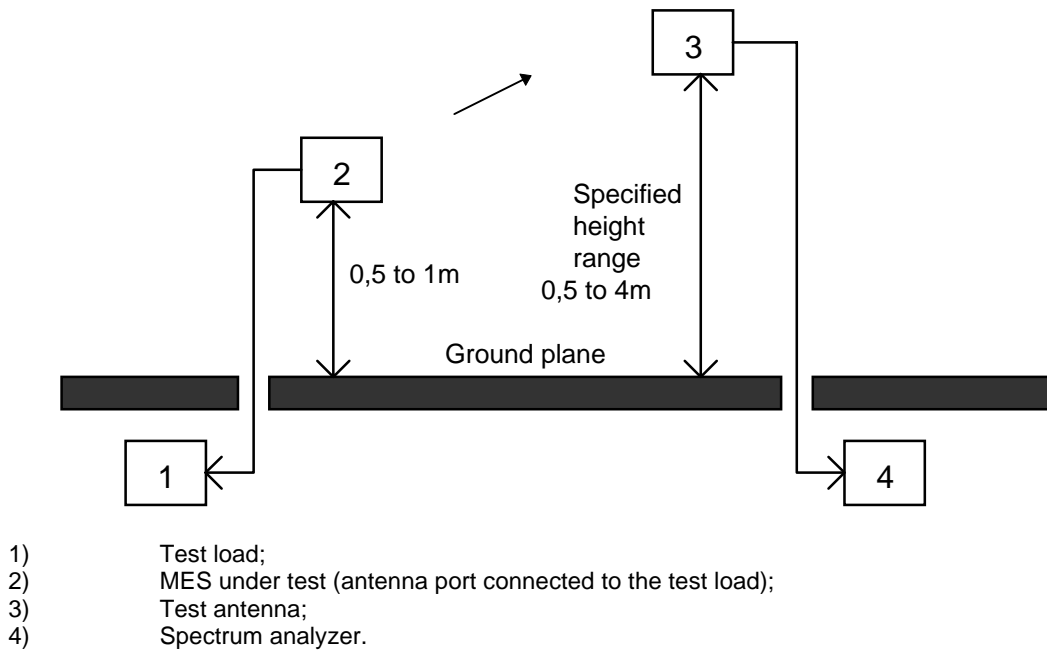

Figure C.3: Measurement arrangement No. 3

Measurement arrangement No. 3 of figure C.3 shall be used for measurement of radiated emissions of the cabinet.

The procedure is a peak measurement as in subclause C.2.1.

The same method as in subclause C.2.1 shall be applied with the exception that measurement arrangement No. 3 replaces measurement arrangement No. 1 (measurement arrangement No. 2 remains the same for the relative measurement).

C.3 Measurement procedure for radiated emissions (average)

C.3.1 Measurement procedure for average radiated emissions of the MES

Measurement arrangement No. 1 of figure C.1 shall be used.

- a) For each measurement bandwidth, the following actions shall be performed:

The MES shall be placed in the reference position as described in subclause C.1.3.

The test antenna shall have the same polarization as the MES and connected to a spectrum analyzer, eventually through a suitable entry filter to avoid overloading of the spectrum analyzer. Precautions may be required to ensure that the filter does not attenuate the harmonics of the carrier.

The test antenna and the entry filter shall be suitable for the measured frequency band, and replaced by other each time it will be necessary.

The spectrum analyzer shall be tuned to the measurement bandwidth to analyse.

The resolution bandwidth of the spectrum analyzer shall be set to a suitable value to correctly perform the measurement, and the average function shall be activated. The video bandwidth shall be set to the same value as the resolution bandwidth.

- b) The test antenna shall be raised or lowered through the specified height range to look for the maximum received signal on the spectrum analyzer (this step may not be necessary if the test site is an anechoic chamber or an indoor test site).
The EIRP shall be averaged until the variance over the measured bandwidth is less than 1 dB. The averaged value shall be recorded.

- c) The procedure shall be repeated from a) to b) with the other measurement bandwidths to cover the whole frequency range to be analysed.
- d) In the case where the test site has been calibrated before, the absolute measurement is sufficient to determine the actual value of EIRP of the radiated emissions. The precise knowledge of distance between the MES and the test antenna, the characteristics of the test antenna and the input filter allow the determination of the EIRP radiated by the MES.
- e) In the case where the test site cannot be calibrated, a relative measurement can be done according to the following procedure:

Using measurement arrangement No. 2 of figure C.2, a substitution antenna shall replace the MES in the same position where was the MES antenna. It shall be connected to the signal generator.
- f) The signal generator shall be tuned to the centre frequency of each measurement bandwidth. The substitution antenna shall be suitable for this frequency.
The spectrum analyzer shall be tuned to the measurement bandwidth to analyse and put in the same conditions as for the measurement with the MES with the average function activated.

The level of the signal generator shall be adjusted to give the same signal level on the spectrum analyzer as in b) when averaged until the variance over the measured bandwidth is less than 1 dB. The output level of the signal generator shall be recorded.
This value, after corrections due to the gain of the substitution antenna and the cable loss between the signal generator and the substitution antenna, is the radiated emission level of the MES.
- g) The f) procedure shall be repeated with the other measurement bandwidths to cover the whole frequency range to be analysed.
- h) a) to g) shall be repeated with test antennas of the opposite polarization for the unwanted emission measurements.

C.3.2 Measurement procedure for average radiated emissions of the cabinet

This method of measurement applies to transmitters having an antenna socket and has to be performed in addition to conducted measurements of the MES for unwanted emissions.

Measurement arrangement No. 3 of figure C.3 shall be used for measurement of radiated emissions of the cabinet.

The procedure is an average measurement as in subclause C.3.1.

The same method as in subclause C.3.1 shall be applied with the exception that measurement arrangement No. 3 replaces measurement arrangement No. 1 (measurement arrangement No. 2 remains the same for the relative measurement).

Annex D (normative): Procedures for measurement of conducted emissions

D.1 General

This annex contains the procedure for conducted emission measurements.

It is recognized that for some parameters, alternative test methods may exist. It is the responsibility of the test laboratory to ensure that any alternative test method used yields results identical to those described in this TBR.

D.1.1 Test site

There are no specific requirements for the test site for conducted measurements except that they shall be performed in such a way as to ensure that there is no interference to operational satellite and terrestrial systems.

D.1.2 Test set-up

Measurement arrangement of figure D.1 shall be used.

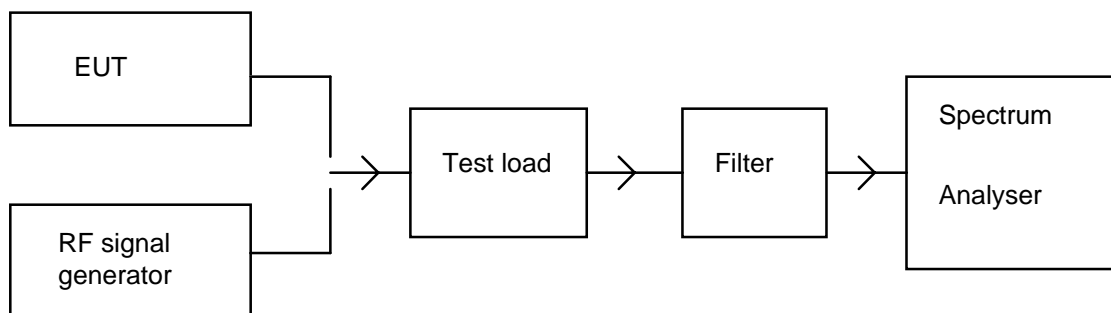

Figure D.1: Measurement arrangement for conducted emissions

The antenna port of the MES shall be connected to a spectrum analyzer through a test load and eventually an appropriate filter to avoid overloading of the spectrum analyzer.

Precautions may be required to ensure that the test load does not generate or that the filter does not attenuate, the harmonics of the carrier. The entry filter shall be suitable for the measured frequency band, and replaced by another each time it will be necessary.

The spectrum analyzer noise floor shall be at least 6 dB below the minimum value to be measured.

D.2 Measurement procedure for conducted emissions (peak)

- a) For each measurement bandwidth, the following actions shall be performed:

The spectrum analyzer shall be tuned to the measurement bandwidth to analyse.

The resolution bandwidth of the spectrum analyzer shall be set to a suitable value to correctly perform the measurement, and the peak hold function shall be activated. The video bandwidth shall be set to at least 3 times the resolution bandwidth.

- b) The peak power detected value of each discrete signal having a level equal or greater than 6 dB below the specified limit shall be recorded.
- c) The procedure shall be repeated from a) to b) with the other measurement bandwidths to cover all the spectrum band which is required to be measured.
- d) The actual value of EIRP of the equivalent radiated emissions in each measurement bandwidth shall be derived by adding either the MES maximum antenna gain or the declared gain at the spurious emission frequency to the power value read from the spectrum analyzer.

D.3 Measurement procedure for conducted emissions (average)

- a) For each measurement bandwidth, the following actions shall be performed:

The resolution bandwidth of the spectrum analyzer shall be set to a suitable value to correctly perform the measurement, and the average function shall be activated. The video bandwidth shall be set to the same value as the resolution bandwidth.

The measurement time should be such that the difference of the measured levels, averaged over subsequent measurement samples, is less than 1 dB, or a measurement time of 100 ms may be used if the measured values comply with the applicable limits.

The averaged power density value within the measured bandwidth shall be recorded.

- c) The procedure shall be repeated from a) to b) with the other measurement bandwidths to cover the whole frequency range to be analysed.
- d) The actual value of EIRP of the radiated emissions in each measurement bandwidth shall be derived by adding the MES maximum antenna gain measured at the normal operating frequency to the power spectral density value read from the spectrum analyzer.

Annex E (informative): Explanation of nominated bandwidth

E.1 Introduction

This annex contains a graphical representation of the nominated bandwidth definition given in subclause 3.1

E.2 Interpretation of Parameters [B_n , f_c , a , b]

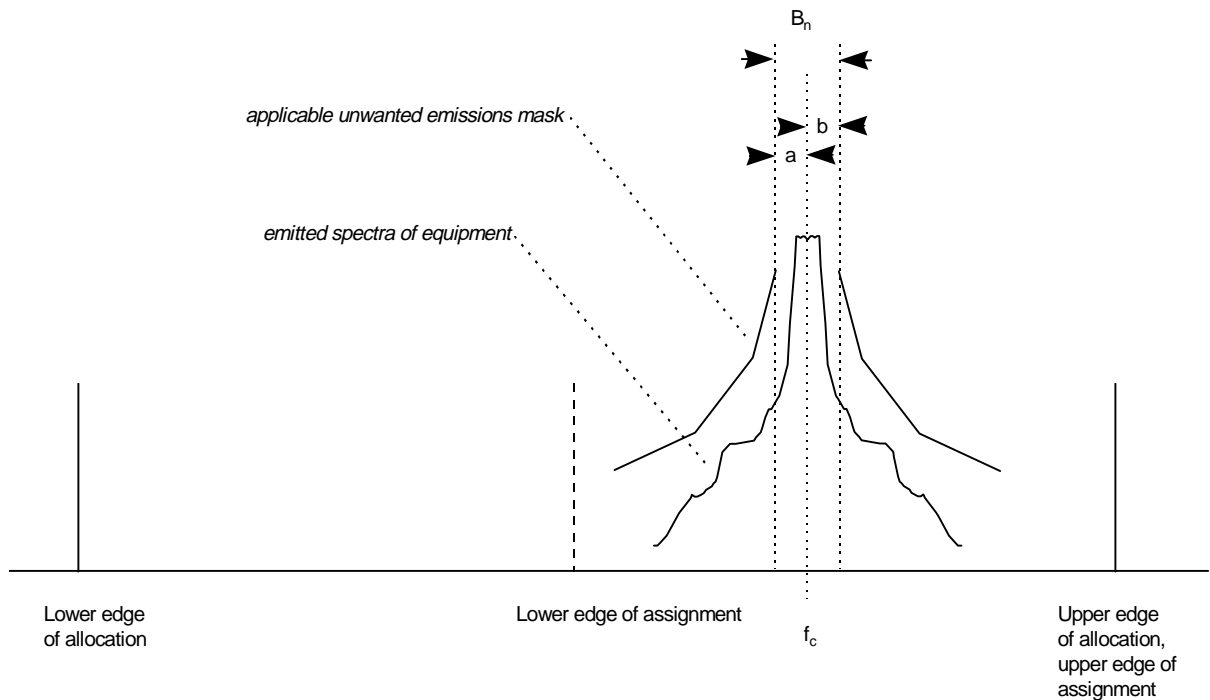

Figure E.1: Nominated bandwidth and Unwanted Emissions Mask

The centre frequency of the emitted spectra has been defined as f_c ; the values of a and b define the *nominated bandwidth* B_n . The value of B_n is chosen, such that the unwanted emissions mask is not exceeded by the emitted spectra - in this example, it can be seen that the nominated bandwidth could be reduced without exceeding the limits of the mask.

E.3 Choice of nominated bandwidth

The choice of the nominated bandwidth is made by the applicant according to the bandwidth and shape of the spectral emission of the equipment. The optimum choice of nominated bandwidth will maximise the available operating frequency range of the MES, and this is achieved by selecting nominated bandwidth as narrow as possible without exceeding the applicable unwanted emissions masks. To illustrate this, two examples are given in Figure E.2. The figures show occupied channels represented by carrier frequency (f_1 , f_2) and the unwanted emission mask.

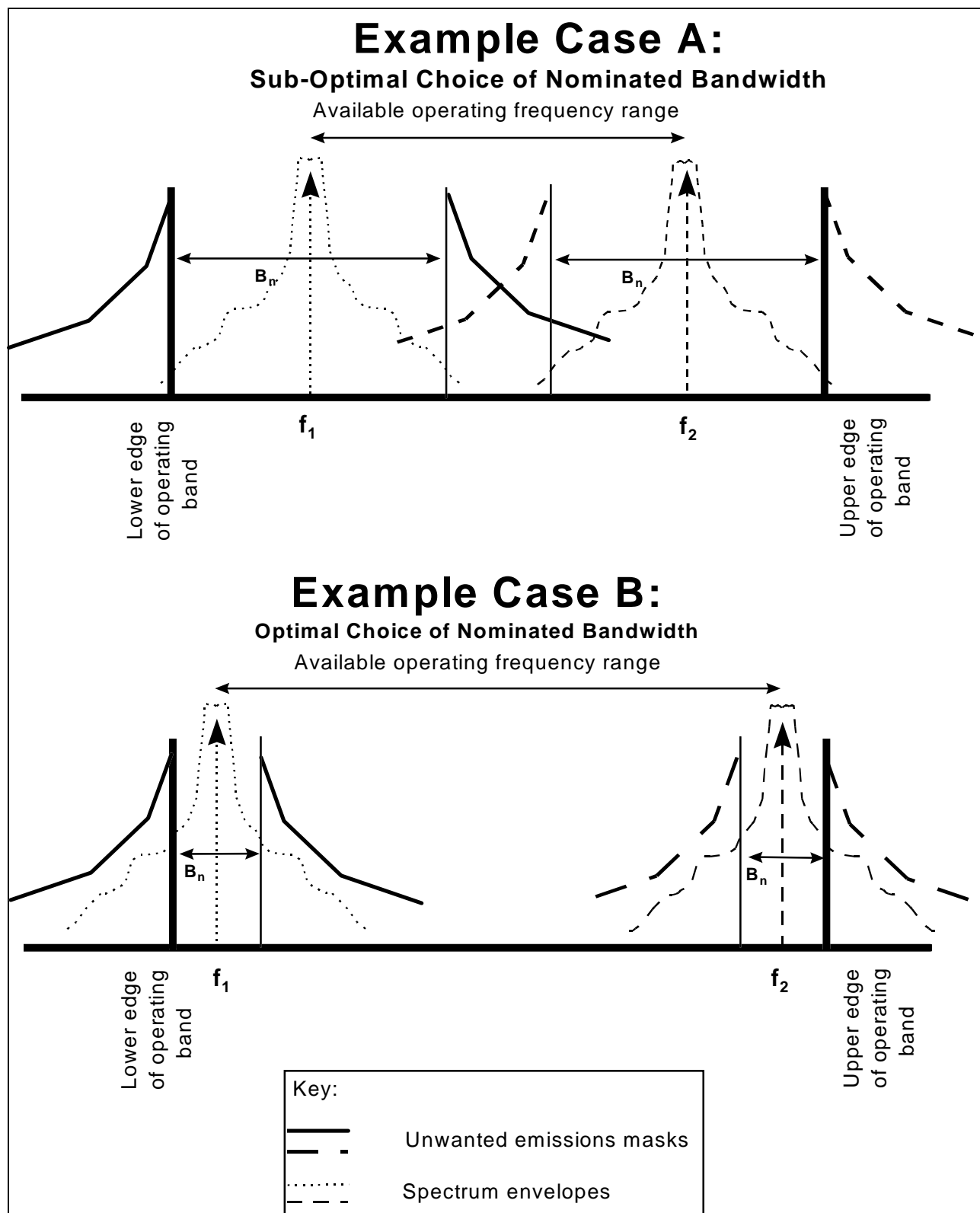

Figure E.2: Choice of nominated bandwidth

In Case A, the lower carrier (centre frequency f_1) is shown operating at its' lowest allowable frequency, with the nominated bandwidth adjacent to the edge of the assignment. Similarly, the upper carrier is shown in the highest allowable frequency, centre frequency f_2 . The available tuning range for the carrier is shown.

In Case B, a similar situation is shown, but with a smaller nominated bandwidth. The uppermost and lowermost channels are operating closer to the band edges, and thus the available tuning range is greater.

E.4 Maximum value for nominated bandwidth

The maximum value for the nominated bandwidth (B_n) is defined in subclause 3.1 so that the frequency interval ($f_c - a, f_c + b$) shall not encompass more than either:

- i) when $a = b$, 4 nominal carrier frequencies (i.e. five channel spacing) for narrow-band systems;
- ii) when $a \neq b$, 1 nominal carrier frequency (i.e. two channel spacing) for narrow-band systems; or
- iii) 1 nominal carrier frequency (i.e. two channel spacing) for wide-band systems.

NOTE: In the following diagrams, f_c represents the actual frequency of transmission

For case (i), the maximum value for the value of B_n is thus:

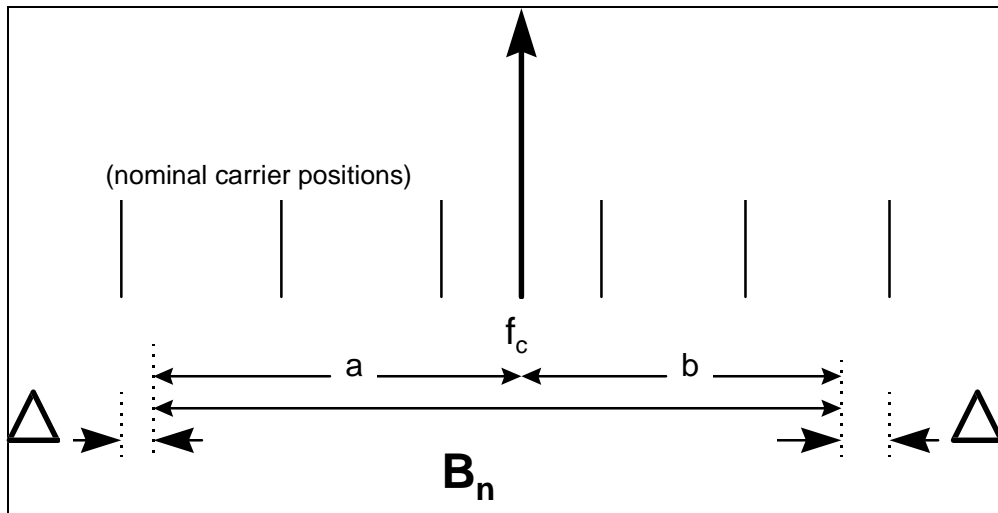

Figure E.3: Maximum value of nominated bandwidth for Case (i)

(When Δ is very small, B_n approaches 5 channel spacing and contains only 4 nominal carriers).

For case (ii), the maximum value for the value of B_n is thus:

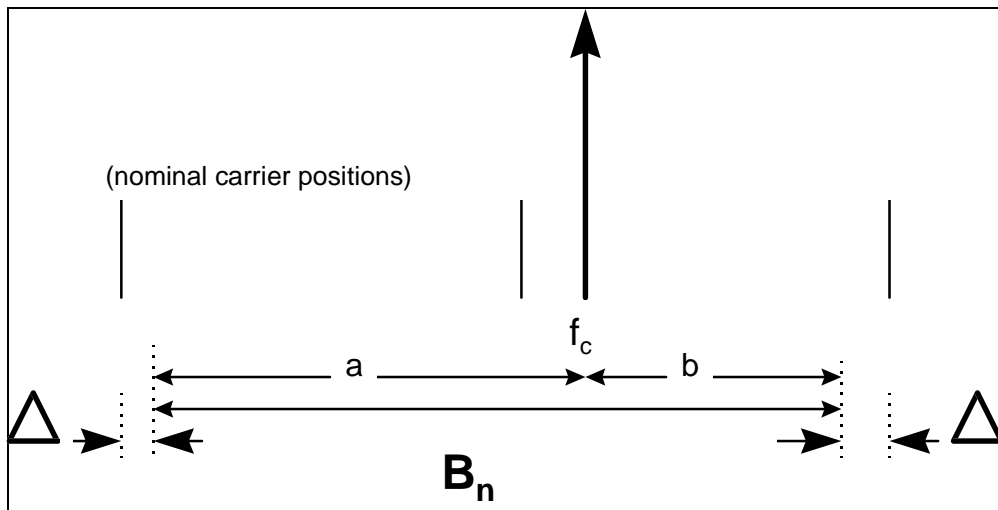

Figure E.4: Maximum value of nominated bandwidth for Case (ii)

(When Δ is very small, B_n approaches 2 channel spacing and contains only 1 nominal carrier).

For case (iii), where the values of a and b are equal, the maximum value for the value of B_n is thus:

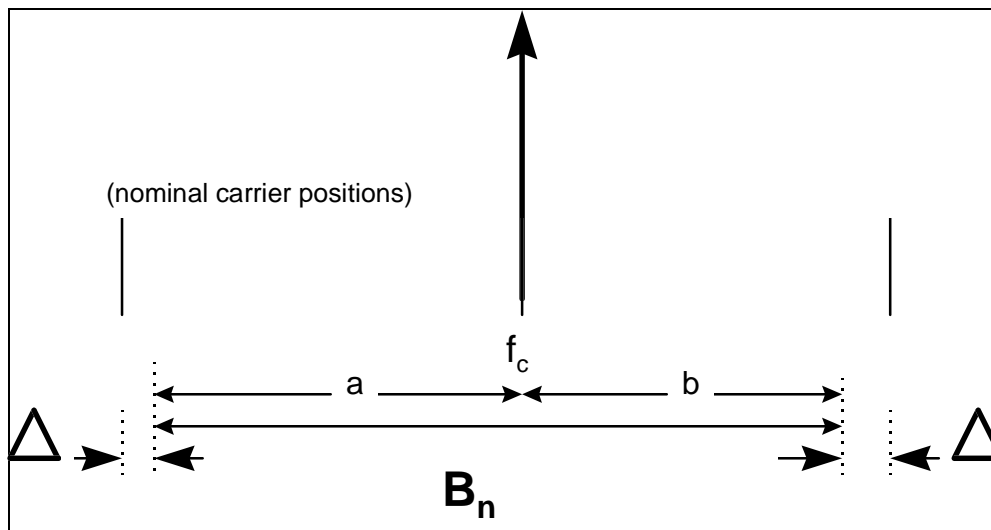

Figure E.5: Maximum value of nominated bandwidth for Case (iii)

(When Δ is very small, B_n approaches 2 channel spacing and contains only 1 nominal carrier).

For case (iii), where the values of a and b are not equal, the maximum value for the value of B_n is thus:

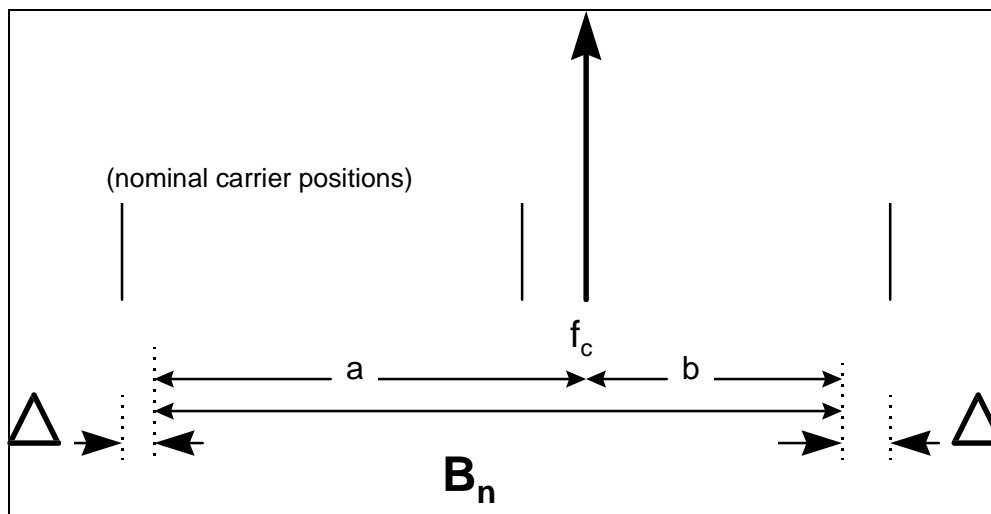

Figure E.6: Maximum value of nominated bandwidth for Case (iii)

(When Δ is very small, B_n approaches 2 channel spacing and contains only 1 nominal carrier).

Annex F (normative): The TBR Requirements Table

Notwithstanding the provisions of the copyright clause related to the text of this TBR, ETSI grants that users of this TBR may freely reproduce the TBR-RT proforma in this annex so that it can be used for its intended purposes and may further publish the completed TBR-RT.

Table F.1: TBR Requirements Table (TBR-RT)

TBR Reference			TBR 042		
No.	Category	Reference	TBR-R	Status	Support
1	4.1 & 4.3	5	Unwanted emissions outside the band 1 980,1 to 2 009,9 MHz	M	
2	4.1 & 4.3	6	Unwanted emissions within the bands 1 980,1 to 2 009,9 MHz, 1 978,1 to 1 980,1 MHz and 2 009,9 to 2 011,9 MHz	M	
3	4.1 & 4.3	7	Unwanted emissions in carrier-off state	M	
4	4.1 & 4.3	8.2.1	Processor monitoring	M	
5	4.1 & 4.3	8.2.2	Transmit frequency generation subsystem monitoring	M	
6	4.1 & 4.3	8.3.1	Network control authorization	M	
7	4.1 & 4.3	8.3.2	Transmit frequency control	M	
8	4.1 & 4.3	8.4	Fellow radio stations in a dual-mode or multi-mode terminal	O	
9	4.1 & 4.3	9	Equipment identity	M	

Key to columns:

No.	TBR-RT entry number;
Category	Category of essential requirement as per Article 4 of the SES Directive;
Reference	Clause reference within this TBR of the supporting text for the entry;
TBR-R	Title of entry within this TBR-RT;
Status	Status of the entry: M = Mandatory, shall be implemented under all circumstances; O = Optional, need not be provided, but if provided shall be implemented in accordance with the requirements;
Support	Does the equipment support the essential requirement of this entry: Y/N.

Annex G (informative): Bibliography

- Council Directive 93/97/EEC of 29 October 1993 supplementing Directive 91/263/EEC in respect of satellite earth station equipment (Satellite Earth Station or SES Directive).
- Council Directive 91/263/EEC of 29 April 1991 on the approximation of the laws of the Member States concerning telecommunications terminal equipment, including the mutual recognition of their conformity (Terminal or TTE Directive).
- ETS 300 734: "Satellite Personal Communications Networks (S-PCN); MES, including handheld earth stations, for S-PCN in the 2,0 GHz bands, providing voice and/or data communications under the MSS".
- ETS 300 735: "Satellite Personal Communications Networks (S-PCN); Network Control Facilities for MES, including handheld earth stations, for S-PCN in the 1,6/2,5 GHz and the 2,0 GHz bands, providing voice and/or data communications under the MSS".
- Council Directive 73/23/EEC of 19 February 1973 on the harmonization of the laws of Member States relating to electrical equipment designed for use within certain voltage limits (Low Voltage Directive).
- Council Directive 92/31/EEC of 28 April 1992 amending Directive 89/336/EEC on the approximation of the laws of the Member States relating to electromagnetic compatibility (EMC Directive).
- CEN/CENELEC EN 55022: "Limits and methods of measurements of radio interferers characteristics of information technology equipment".
- IEC Publication 68-2-1: Environmental testing Part 2: Tests - Tests A: Cold.
- IEC Publication 68-2-2: Basic environmental testing procedures Part 2: Tests - Tests B: Dry heat.
- IEC Publication 68-2-36: Basic environmental testing procedures Part 2: Tests - Tests Fdb: Random vibration wide band - Reproducibility medium.
- Construction of an Anechoic Chamber: Technical Report ZVEI AK-R 90/20.

History

Document history			
February 1997	Public Enquiry	PE 97292	1997-02-14 to 1977-07-18
October 1997	Vote	V 9752:	1997-10-28 to 1997-12-26
February 1998	First Edition		