



TECHNICAL
BASIS for
REGULATION

TBR 30

December 1997

Source: ETSI TC-SES

Reference: DTBR/SES-00008

ICS: 33.020

Key words: Satellite, earth station, SNG, TES, broadcasting, FSS, TV, type approval

**Satellite Earth Stations and Systems (SES);
Satellite News Gathering
Transportable Earth Stations (SNG TES)
operating in the 11-12/13-14 GHz frequency bands**

ETSI

European Telecommunications Standards Institute

ETSI Secretariat

Postal address: F-06921 Sophia Antipolis CEDEX - FRANCE

Office address: 650 Route des Lucioles - Sophia Antipolis - Valbonne - FRANCE

X.400: c=fr, a=atlas, p=etsi, s=secretariat - **Internet:** secretariat@etsi.fr

Tel.: +33 4 92 94 42 00 - Fax: +33 4 93 65 47 16

Copyright Notification: No part may be reproduced except as authorized by written permission. The copyright and the foregoing restriction extend to reproduction in all media.

© European Telecommunications Standards Institute 1997. All rights reserved.

Contents

Foreword	5
Introduction	5
1 Scope	7
2 Normative references	8
3 Definitions and abbreviations	8
3.1 Definitions	8
3.2 Abbreviations	10
4 Requirements	10
4.1 Off-axis EIRP emission density within the band(s)	10
4.1.1 Justification	10
4.1.2 Specification	10
4.1.3 Conformance tests	10
4.2 Off-axis spurious radiation	11
4.2.1 Justification	11
4.2.2 Specification	11
4.2.3 Conformance tests	12
4.3 On-axis spurious radiation	12
4.3.1 Justification	12
4.3.2 Specification	12
4.3.3 Conformance tests	12
4.4 Transmit polarization discrimination	12
4.4.1 Justification	12
4.4.2 Specification	12
4.4.2.1 Contour of -1 dB	12
4.4.2.2 Contour of -10 dB	12
4.4.3 Conformance tests	12
4.5 ElectroMagnetic Compatibility (EMC)	13
4.6 Mechanical (antenna pointing)	13
4.6.1 Justification	13
4.6.2 Specification	13
4.6.3 Conformance tests	13
5 Test methods	13
5.1 Off-axis EIRP density within the band	14
5.1.1 Test method	14
5.1.1.1 Transmit output power density	14
5.1.1.1.1 Test site	15
5.1.1.1.2 Method of measurement	15
5.1.1.2 Antenna transmit gain	15
5.1.1.2.1 General	15
5.1.1.2.2 Test site	15
5.1.1.2.3 Method of measurement	16
5.1.1.3 Antenna transmit radiation patterns	17
5.1.1.3.1 General	17
5.1.1.3.2 Test site	17
5.1.1.3.3 Method of measurement	17
5.1.1.3.4 Co-polar radiation pattern - azimuth	17
5.1.1.3.5 Co-polar radiation pattern - elevation	18
5.1.1.3.6 Cross-polar radiation pattern - azimuth	19
5.1.1.3.7 Cross-polar radiation pattern - elevation	19
5.1.2 Computation of results	20

5.2	Off-axis spurious radiation	20
5.2.1	Test method.....	20
5.2.1.1	Up to 1,0 GHz	21
5.2.1.1.1	Test site.....	21
5.2.1.1.2	Measuring receivers.....	21
5.2.1.1.3	Procedure.....	21
5.2.1.2	Above 1,0 GHz.....	21
5.2.1.2.1	Identification of the significant frequencies of spurious radiation	22
5.2.1.2.1.1	Test site.....	22
5.2.1.2.1.2	Procedure.....	22
5.2.1.2.2	Measurement of radiated power levels of identified spurious radiation	22
5.2.1.2.2.1	Test site.....	22
5.2.1.2.2.2	Procedure.....	22
5.2.1.2.3	Measurement of conducted spurious radiation at the antenna flange.....	23
5.2.1.2.3.1	Test site.....	23
5.2.1.2.3.2	Procedure.....	23
5.3	On-axis spurious radiation	24
5.3.1	Test method.....	24
5.3.1.1	General	24
5.3.1.2	Method of measurement.....	24
5.4	Transmit polarization discrimination.....	25
5.4.1	General	25
5.4.2	Test site	25
5.4.3	Method of measurement.....	25
5.5	Mechanical (antenna pointing)	26
5.5.1	Test method.....	26
6	Test methods for SNG TES subsystems.....	27
6.1	Antenna subsystem replacement.....	27
Annex A (normative):	The TBR Requirements Table (TBR-RT)	28
Annex B (informative):	Pointing stability methodology.....	29
Annex C (informative):	Bibliography	30
History		31

Foreword

This Technical Basis for Regulation (TBR) has been produced by the Satellite Earth Stations and Systems (SES) Technical Committee of the European Telecommunications Standards Institute (ETSI).

Introduction

The SES Directive [1] which supplements the TTE Directive [2] concerns the harmonization of conditions for the placing on the market of such equipment.

Two classes of standards are applicable to satellite earth station equipment. European Telecommunication Standards (ETSS) give the full technical specifications for this equipment, whereas Technical Bases for Regulation (TBRs) give the essential requirements under the SES Directive [1] and the TTE Directive [2] for placing such equipment on the market. Receive-only equipment, not intended for terrestrial connection to the public telecommunications network, may be put into use. Nothing in this TBR is construed to prevent the use of Community internal production control procedures as set out in the annexes to the two Directives for such receive-only equipment. This TBR is based on ETS 300 327 (see annex C, Bibliography).

Blank page

1 Scope

This Technical Basis for Regulation (TBR) specifies the technical requirements that apply to Satellite News Gathering (SNG) Transportable Earth Stations (TESs) for compliance with Articles 4.1 and 4.3 of the SES Directive [1].

These SNG TESs have the following characteristics:

The SNG TESs are designed for Satellite News Gathering (SNG) which can be either an unforeseen or pre-planned activity.

SNG TES is capable of transmitting television signals and associated audio or programme audio only towards a satellite positioned on the geostationary orbit. The modulation method may be either analogue or digital. Such transmissions are point-to-point or point-to-multipoint but not for general broadcast reception.

The SNG TESs are designed for relocation at any time to a different fixed operating location but are not intended to operate during the relocation period. The SNG TESs can be either vehicle mounted or packed for transportation. The SNG TESs considered in this TBR are those designed to operate whilst stationary.

The SNG TESs are operating in the following bands allocated to the Fixed Satellite Services (FSS):

- 10,70 GHz to 11,70 GHz (space-to-earth);
- 12,50 GHz to 12,75 GHz (space-to-earth);
- 12,75 GHz to 13,25 GHz (earth-to-space);
- 13,75 GHz to 14,25 GHz (earth-to-space);
- 14,25 GHz to 14,50 GHz (earth-to-space).

Frequencies could be selected from through the entire frequency range or be restricted to a range completely enclosed within those bands. These bands are partly shared between FSS and Fixed Service (FS).

At present the ITU Radio Regulations [5] restrict the use of the 13,75 GHz to 14,00 GHz band to earth stations having an antenna diameter of 4,5 m or greater and having a transmitting EIRP between 68 dBW and 85 dBW.

The SNG TESs use linear polarization.

The SNG TESs operate through a geostationary satellite at least 3° away from any other geostationary satellite operating in the same frequency band and covering the same area.

The SNG TES antenna diameter does not exceed 5 m, or equivalent corresponding aperture.

The SNG TESs are designed for attended operation.

This TBR applies to the SNG TES with its ancillary equipment and its various terrestrial ports, and operated under the conditions which are within the ranges of humidity, temperature and supply voltage declared by the manufacturer.

The requirements have been selected to ensure an adequate level of compatibility with other radio services. The levels, however, do not cover extreme cases which may occur in any location but with a low probability of occurrence.

This TBR may not cover those cases where a potential source of interference which is producing individually repeated transient phenomena or a continuous phenomenon is present, e.g. a radar or broadcast site in the near vicinity. In such a case it may be necessary to use special protection applied to either the source of interference, or the interfered part or both.

This TBR does not contain any requirement, recommendation or information about the installation of the SNG TESs. Compliance of a SNG TES to the requirements of this TBR does not imply compliance to any requirement related to the use of the SNG TES (e.g. licensing requirements).

2 Normative references

This TBR incorporates by dated or undated reference, provisions from other publications. These references are cited at the appropriate places in the text and the publications are listed hereafter. For dated references, subsequent amendments to, or revisions of any of these publications apply to this TBR only when incorporated into it by amendment or revision. For undated references the latest edition of the publication referred to applies.

- [1] Council Directive 93/97/EEC of 29 October 1993 supplementing Directive 91/263/EEC in respect of satellite earth station equipment. Called "SES Directive" in the present document.
- [2] Council Directive 91/263/EEC of 29 April 1991 on the approximation of the laws of Member States concerning telecommunications terminal equipment, including the mutual recognition of their conformity. Called "TTE Directive" in the present document.
- [3] ETS 300 673 (1996): "Radio Equipment and Systems (RES); ElectroMagnetic Compatibility (EMC) standard for 4/6 GHz and 11/12/14 GHz Very Small Aperture Terminal (VSAT) equipment and 11/12/13/14 GHz Satellite News Gathering (SNG) Transportable Earth Station (TES) equipment".
- [4] CISPR 16-1 (1993): "Specification for radio interference measuring apparatus and measurement methods; Part 1: Radio disturbance and immunity measuring apparatus" (Annex G: Validation of the open area test site for the frequency range of 30 MHz to 1 000 MHz).
- [5] ITU Radio Regulations.

NOTE: This TBR also contains a number of informative references which have been included to indicate the sources from which various material has been derived, hence they do not have an associated normative reference number. Details of these publications are given in annex C, bibliography.

3 Definitions and abbreviations

3.1 Definitions

For the purposes of this TBR, the following definitions apply:

carrier-off state: That state where the SNG TES is electrically powered and is not transmitting a signal.

NOTE 1: A SNG TES is considered to be in the carrier-off state when one of the following conditions is satisfied:

- the High Power Amplifier (HPA) is in standby mode;
- the transmit subsystem is not switched to the antenna.

carrier-on state: That state where the SNG TES is transmitting a signal.

cross-polarization discrimination: The ratio of the on-axis co-polar gain to the cross-polar gain in a given direction, at a transmit or receive frequency. It is usually expressed in dB.

exclusion band: The exclusion band is centred on the transmit frequency and is equal to 5 times the occupied bandwidth.

manufacturer: The legal entity responsible under the terms of Council Directive 93/97/EEC (SES Directive) [1] for placing the product on the market in a member state.

occupied Bandwidth (Bo): For a digital modulation scheme the width of the signal spectrum 10 dB below the maximum inband density. For an analogue modulation scheme the occupied bandwidth (Bo) is defined as follows:

$$B_o = \Delta F_{pp} + 2f_m$$

with

ΔF_{pp} = peak-to-peak frequency deviation of the TV-carrier for a 1 V peak-to-peak test tone at the pre-emphasis network cross-over frequency in Hz; and

f_m = top video baseband frequency (e.g. 5 MHz).

Satellite News Gathering Transportable Earth Station (SNG TES): Equipment capable of transmitting television signals and associated audio or programme audio only towards a satellite positioned on the geostationary orbit. The modulation method may be either analogue or digital. Such transmissions are point-to-point or point-to-multipoint but not for general broadcast reception.

The SNG TES usually comprises the main parts, as defined below, and all power, interconnecting and other cables required for proper operation of the equipment as follows:

- 1) the antenna subsystem, which converts the incident electromagnetic wave into a guided wave and vice versa and which includes any mounting that may be required;
- 2) the transmit subsystem, which is composed of the frequency translation equipment and the high power amplifier;
- 3) the receive subsystem, which consists of the low noise amplifier and the frequency translation equipment;
- 4) the ground communications subsystem, which consists of modulation and demodulation equipment, either analogue or digital, and associated baseband equipment;
- 5) the monitoring and control subsystem which consists of test equipment together with a transmitter identification system if implemented;
- 6) the communications subsystem which consists of and a facility for two way communication if implemented;
- 7) the power subsystem, which consists of any power generation equipment that may be required;
- 8) the transportation subsystem, which consists of either a vehicle for vehicle mounted SNG TES or flight cases for "flyaway" SNG TES.

spurious radiation: Any radiation outside the exclusion band.

transmit frequency band: One of the following frequency bands, or a part of them, within which the SNG TES is able to transmit its carrier:

12,75 GHz to 13,25 GHz;

13,75 GHz to 14,50 GHz.

The transmit frequency bands of the SNG TES are declared by the manufacturer.

NOTE 2: An SNG TES may be designed for several transmit frequency bands.

3.2 Abbreviations

For the purposes of this TBR, the following abbreviations apply:

EIRP	Equivalent Isotropically Radiated Power
EMC	ElectroMagnetic Compatibility
ETS	European Telecommunication Standard
EUT	Equipment Under Test
FSS	Fixed Satellite Service
HPA	High Power Amplifier
LNA	Low Noise Amplifier
LNB	Low Noise Block
modem	MODulator/DEModulator
RF	Radio Frequency
SNG TES	Satellite News Gathering Transportable Earth Station
TBR	Technical Basis for Regulation
VSAT	Very Small Aperture Terminal

4 Requirements

4.1 Off-axis EIRP emission density within the band(s)

Off-axis EIRP emission density (co-polar and cross-polar) within the transmit frequency band(s).

4.1.1 Justification

Protection of other satellite (uplink) systems.

4.1.2 Specification

The maximum EIRP in any 40 kHz band of the co-polarized component in any direction ϕ degrees from the antenna main beam axis shall not exceed the following limits:

33 - 25 log ϕ dBW	where	$2,5^\circ \leq \phi \leq 7,0^\circ$
+12 dBW	where	$7,0^\circ < \phi \leq 9,2^\circ$
36 - 25 log ϕ dBW	where	$9,2^\circ < \phi \leq 48^\circ$
-6 dBW	where	$48,0^\circ < \phi \leq 180^\circ$

Where ϕ is the angle, in degrees, between the main beam axis and the direction considered.

In addition the maximum EIRP in any 40 kHz band of the cross-polarized component in any direction ϕ degrees from the antenna main beam axis shall not exceed the following limits:

23 - 25 log ϕ dBW	where	$2,5^\circ \leq \phi \leq 7,0^\circ$
+2 dBW	where	$7,0^\circ < \phi \leq 9,2^\circ$

Where ϕ is the angle, in degrees, between the main beam axis and the direction considered.

4.1.3 Conformance tests

Conformance tests shall be carried out as per subclause 5.1.1 with the results being computed in accordance with subclause 5.1.2.

4.2 Off-axis spurious radiation

4.2.1 Justification

To limit the level of interference to terrestrial and satellite radio services.

4.2.2 Specification

- 1) The SNG TES shall not exceed the limits for radiated field strength over the frequency range from 30 MHz to 1 000 MHz specified in table 1.

Table 1: Limits of radiated field strength at a test distance of 10 m

Frequency range (MHz)	Quasi-peak limits (dB μ V/m)
30 to 230	30
230 to 1 000	37

The lower limits shall apply at the transition frequency.

- 2) This specification applies outside the exclusion band.

For the carrier-off state, the off-axis spurious EIRP from the SNG TES, in any 100 kHz band, shall not exceed the limits given in table 2, for all off-axis angles greater than 7°:

Table 2: Limits of spurious EIRP with carrier-off

Frequency range (GHz)	EIRP (dBpW)
1,0 - 10,7	48
10,7 - 21,2	54
21,2 - 40,0	60

The lower limits shall apply at the transition frequencies.

- 3) This specification applies outside the exclusion band.

For the carrier-on state, the off-axis spurious EIRP in any 100 kHz band from the SNG TES, shall not exceed the limits given in table 3, for all off-axis angles greater than 7°:

Table 3: Limits of spurious EIRP with carrier-on

Frequency range (GHz)	EIRP (dBpW)
1,0 - 3,40	49
3,40 - 10,7	55
10,7 - 11,7	61
11,7 - 21,2	78 (see note)
21,2 - 40,0	67
NOTE:	This limit may be exceeded in a frequency band which shall not exceed 80 MHz centred on the carrier frequency.

The lower limits shall apply at the transition frequency.

In the frequency bands from 25,5 GHz to 26,5 GHz and from 27,5 GHz to 29,0 GHz, for any 20 MHz band within which one or more spurious signals exceeding the above limit of 67 dBpW are present, then the power of each of those spurious signals exceeding the limit shall be added in watts and the total shall not exceed 78 dBpW.

For SNG TESs designed to transmit simultaneously several different carriers (multicarrier operation), the above limits apply to each individual carrier when transmitted alone.

4.2.3 Conformance tests

Conformance tests shall be carried out in accordance with subclause 5.2.

4.3 On-axis spurious radiation

4.3.1 Justification

To limit the level of interference to satellite radio services.

4.3.2 Specification

In the transmit frequency band outside the exclusion band the EIRP spectral density of the spurious radiation shall not exceed 4 dBW in any 4 kHz band.

For SNG TEs designed to transmit simultaneously several different carriers (multicarrier operation), the above limits apply to each individual carrier when transmitted alone.

NOTE 1: The on-axis spurious radiations, outside the transmit frequency band(s), are indirectly limited by subclause 4.2.2. Consequently no specification is needed.

NOTE 2: Intermodulation limits inside the transmit frequency band(s) are to be determined by system design and are subject to satellite operator specifications.

4.3.3 Conformance tests

Conformance tests shall be carried out in accordance with subclause 5.3.

4.4 Transmit polarization discrimination

4.4.1 Justification

Protection of signals on the orthogonal polarization.

4.4.2 Specification

4.4.2.1 Contour of -1 dB

The polarization discrimination of the antenna system in the transmit frequency band shall exceed 28 dB within the -1 dB contour of the main beam.

NOTE: Some satellite operators may require improved values of cross-polar discrimination.

4.4.2.2 Contour of -10 dB

The polarization discrimination of the antenna system in the transmit frequency band shall exceed 25 dB within the -10 dB contour of the main beam.

NOTE: Some satellite operators may require improved values of cross-polar discrimination.

4.4.3 Conformance tests

Conformance tests shall be carried out in accordance with subclause 5.4.

4.5 ElectroMagnetic Compatibility (EMC)

There are no specific EMC requirements under this TBR however ETS 300 673 [3] contains the EMC requirements for SNG TESs.

4.6 Mechanical (antenna pointing)

4.6.1 Justification

Protection of signals to and from both the same and adjacent satellites.

4.6.2 Specification

- a) Pointing stability:
The SNG TES shall not show any sign of distortion and the pointing shall not need adjustment whilst being used in a wind speed which is less than that specified by the manufacturer at which the antenna shall be stowed.
- b) Pointing accuracy capability:
The antenna mount shall allow the position of the antenna transmit main beam axis to be maintained with an accuracy better than the off-axis angle measured when the main beam gain has decreased by 1 dB at any frequency in the equipment operating band, over the full range of azimuth and elevation movement available to the antenna.
- c) Polarization angle alignment capability:
The polarization angle shall be continuously adjustable in a range of at least 180°; it shall be possible to fix the transmit antenna polarization angle with an accuracy better than 1°.
- d) Polarization alignment stability:
The SNG TES shall not show any sign of distortion and the polarization shall not need realignment whilst being used in a wind speed which is under that specified by the manufacturer at which the antenna shall be stowed nor from any accidental mechanical action.

4.6.3 Conformance tests

Conformance tests shall be carried out in accordance with subclause 5.5.

5 Test methods

The values of measurement uncertainty associated with each measurement parameter apply to all of the test cases described in this TBR. The measurement uncertainties shall not exceed the values shown in tables 4 and 5.

Table 4: Measurement uncertainty

Measurement parameter	Uncertainty
Radio frequency	±10 kHz
RF power	±0,75 dB
Conducted spurious	±4 dB
Radiated spurious	±6 dB
Antenna gain	±0,5 dB
Polarization discrimination	±2 dB

Table 5: Measurement uncertainties for antenna gain pattern

Gain relative to the antenna on-axis gain	Uncertainty
< -3 dB	±0,3 dB
-3 dB to -20 dB	±1,0 dB
-20 dB to -30 dB	±2,0 dB
-30 dB to -40 dB	±3,0 dB

For vehicle mounted equipment the EUT, as defined for each test, does not include the transportation subsystem unless agreed between the manufacturer and test house.

The EUT does not include the control and monitoring and power subsystems unless agreed between the manufacturer and test house.

The antenna shall never be rotated around its main beam axis.

All tests with carrier-on shall be conducted with maximum transmit power as declared by the manufacturer.

The modulation shall be by an energy dispersal signal only, as specified by the manufacturer, in the case of an analogue modulation scheme or by a pseudo random bit sequence in the case of a digital modulation scheme.

All technical characteristics and operational conditions declared by the manufacturer shall be entered in the test report.

5.1 Off-axis EIRP density within the band

Off-axis EIRP emission density (co-polar and cross-polar) within the transmit frequency band(s).

5.1.1 Test method

Conformance shall be determined from:

- a) measurement of maximum RF power density entering the antenna feed for the different modulation schemes declared by the manufacturer;
- b) measurement of transmit antenna gain pattern.

To ascertain the off-axis EIRP it is necessary to know the transmit power density and antenna transmit radiation pattern. To ascertain the radiation pattern it is necessary to know the antenna transmit gain.

The following three measurement procedures shall, therefore, be performed:

- a) transmitter output power density (dBW/40 kHz);
- b) antenna transmit gain (dBi);
- c) antenna transmit radiation patterns (dBi).

5.1.1.1 Transmit output power density

For the purposes of this TBR, transmitter output power is defined as the maximum power delivered continuously by the transmitting equipment to the antenna flange.

For the purposes of this test the EUT is defined as the SNG TES excluding the antenna from the antenna flange.

5.1.1.1.1 Test site

There are no requirements for the test site to be used for this test.

5.1.1.1.2 Method of measurement

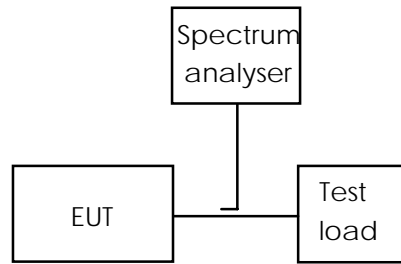

Figure 1: Test arrangement - transmit output power density measurement

- a) The test arrangement shall be as shown in figure 1.
- b) With the carrier being modulated the maximum power supplied to the antenna flange shall be measured in dBW/40 kHz. The coupling factor of the test coupler at the test frequency and the attenuation of any necessary waveguide adapter and any other test equipment (e.g. cable) shall be taken into account. The resolution bandwidth of the spectrum analyser shall be set as close as possible to the specified measuring bandwidth. If the resolution bandwidth is different from the specified bandwidth then bandwidth correction shall be performed.
- c) The measurement shall be performed for each modulation scheme as applicable and for each transmit frequency band at a frequency in the centre of the band, and at a transmit frequency as close to the upper limit of the transmit frequency band as possible regarding the bandwidth of the signal and at a transmit frequency as close to the lower limit of the transmit frequency band as possible regarding the bandwidth of the signal.

5.1.1.2 Antenna transmit gain

5.1.1.2.1 General

For the purposes of this TBR, the antenna transmit gain is defined as the ratio, expressed in decibels (dB), of the power that would have to be supplied to the reference antenna, i.e. an isotropic radiator isolated in space, to the power supplied to the antenna being considered, so that they produce the same field strength at the same distance in the same direction. Unless otherwise specified the gain is for the direction of maximum radiation.

For the purposes of this test the EUT is defined as that part of the SNG TES which comprises the antenna and its flange. The antenna includes the reflector(s), feed, support struts and an enclosure of equal weight/distribution to any electrical equipment normally housed with the feed at the antenna focal point.

5.1.1.2.2 Test site

This test shall be performed on either an outdoor far-field test site or compact test range. However, if the near-field scanner technology to convert near-field measurements to far-field results is proven and sufficiently accurate by reference to tests taken in both regions then antenna measurements may be taken in the near field.

Fully automated systems can be used for these tests providing that the results can be proven to be as accurate as if they were done according to the specified method.

5.1.1.2.3 Method of measurement

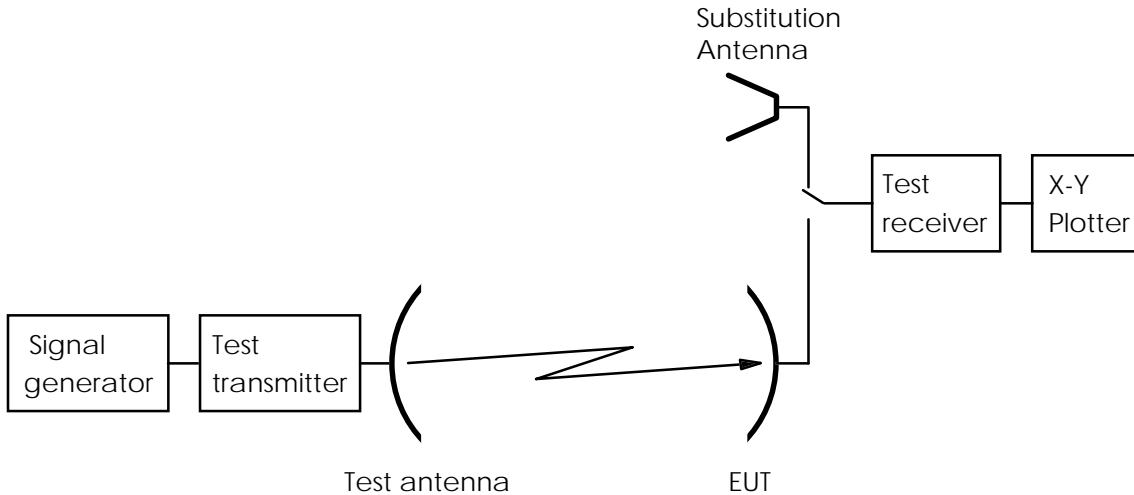

Figure 2: Test arrangement - antenna transmit gain measurement

The following test procedure shall be performed for each transmit frequency band.

- a) The test arrangement shall be as shown in figure 2 with the EUT connected to the test receiver. A signal proportional to the angular position from the servo mechanism shall be applied to the X-axis and the signal level from the test receiver shall be applied to the Y-axis of the plotter.
- b) A test signal at a frequency in the centre of the transmit frequency band shall be transmitted by the test transmitter through the test antenna. The E-plane shall be vertical. The EUT antenna main beam axis shall be aligned with the main beam axis of the test transmitter. The polarizer of the EUT antenna shall be rotated and adjusted such that the E-plane coincides with the E-plane of the test transmitter.
- c) The EUT shall be aligned to maximize the received signal and the X-Y plotter adjusted to give the maximum reading on the chart.
- d) The EUT shall be driven in azimuth in one direction through 10°.
- e) The pattern measurement is then obtained by driving the EUT in azimuth back through boresight to 10° the other side with the plotter recording the results.
- f) The EUT shall be replaced by the substitution antenna and the received signal level maximized.
- g) This level shall be recorded on the X-Y plotter.
- h) The substitution antenna shall be driven in azimuth as in d) and e).
- j) The gain of the EUT shall be calculated from:

$$GEUT = L1 - L2 + C$$

where:

- GEUT is the gain of the EUT (dBi);
- L1 is the level obtained with the EUT (dB);
- L2 is the level obtained with the substitution antenna (dB);
- C is the calibrated gain of the substituted antenna at the test frequency (dBi).

- k) The tests in c) to j) shall be repeated with the frequency changed to 5 MHz above the bottom of the transmit frequency band.
- l) The tests in c) to j) shall be repeated with the frequency changed to 5 MHz below the top of the transmit frequency band.

m) The tests in b) to l) may be performed simultaneously.

5.1.1.3 Antenna transmit radiation patterns

5.1.1.3.1 General

For the purposes of this TBR, the antenna transmit radiation patterns are diagrams relating field strength to the angle of the direction pointed by the antenna at a constant large distance from the antenna.

For the purposes of this test, the EUT is defined as that part of the SNG TES which comprises the antenna and its flange. The antenna includes the reflector(s), feed, support struts and an enclosure of equal weight/distribution to any electrical equipment normally housed with the feed at the antenna focal point.

5.1.1.3.2 Test site

This test shall be performed on either an outdoor far-field test site or compact test range. However if the near-field scanner technology to convert near-field measurements to far-field results is proven and sufficiently accurate by reference to tests taken in both regions then antenna measurements may be taken in the near field.

Fully automated systems can be used for these tests providing that the results can be proven to be as accurate as if they were done according to the specified method.

5.1.1.3.3 Method of measurement

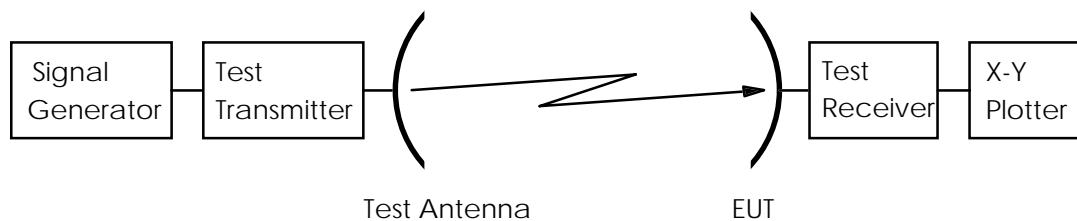

Figure 3: Test arrangement - antenna transmit radiation pattern measurement

5.1.1.3.4 Co-polar radiation pattern - azimuth

The following test procedure shall be performed for each transmit frequency band.

- The test arrangement shall be as shown in figure 3 with the EUT connected to the test receiver. A signal proportional to the angular position from the servo mechanism shall be applied to the X-axis and the signal level from the test receiver shall be applied to the Y-axis of the plotter.
- The frequency of the test signal shall be set to a frequency in the centre of the transmit frequency band.
- The initial E-plane of the test signal radiated by the test transmitter through its antenna shall be vertical. The EUT antenna main beam axis shall be aligned with the main beam axis of the test transmitter. The polarizer of the EUT shall be rotated and adjusted such that its E-plane coincides with the E-plane of the test transmitter. Precise co-polar peaking of the polarization plane shall be done by observing the cross-polar minimum (fine adjustment).
- The EUT shall be aligned to maximize the received signal and the X-Y plotter adjusted to give the maximum reading on the chart.
- The EUT shall be driven in azimuth to -180° .
- The transmit pattern measurement is then obtained by driving the EUT in azimuth from -180° to $+180^\circ$ with the plotter recording the results.

- g) The tests in d) to f) shall be repeated with the frequency changed 5 MHz above the bottom of the transmit frequency band.
- h) The tests in d) to f) shall be repeated with the frequency changed to 5 MHz below the top of the transmit frequency band.
- j) The tests in b) to h) may be performed simultaneously.
- k) The tests in d) to j) shall be repeated with the E-plane of the test signal being horizontal. The frequency of the test signal shall be set to a frequency in the centre of the transmit frequency band. The polarizer of the EUT antenna shall be rotated and adjusted such that its E-plane coincides with the E-plane of the test transmitter. The EUT antenna main beam axis shall be aligned with the main beam axis of the test transmitter precise co-polar peaking of the polarization plane shall be done by observing the cross-polar minimum (fine adjustment).

5.1.1.3.5 Co-polar radiation pattern - elevation

The following test procedure shall be performed for each transmit frequency band.

- a) The test arrangement shall be as shown in figure 3 with the EUT connected to the test receiver. A signal proportional to the angular position from the servo mechanism shall be applied to the X-axis and the signal level from the test receiver shall be applied to the Y-axis of the plotter.
- b) The frequency of the test signal shall be set to a frequency in the centre of the transmit frequency band.
- c) The initial E-plane of the test signal radiated by the test transmitter through its antenna shall be vertical. The EUT antenna main beam axis shall be aligned with the main beam axis of the test transmitter. The polarizer of the EUT shall be rotated and adjusted such that its E-plane coincides with the E-plane of the test transmitter. Precise co-polar peaking of the polarization plane shall be done by observing the cross-polar minimum (fine adjustment).
- d) The EUT shall be aligned to maximize the received signal and the X-Y plotter adjusted to give the maximum reading on the chart.
- e) The EUT shall be driven in elevation to -1° .
- f) The transmit pattern measurement is then obtained by driving the EUT in elevation from -1° to $+70^\circ$ with the plotter recording the results.
- g) The tests in d) to f) shall be repeated with the frequency changed 5 MHz above the bottom of the transmit frequency band.
- h) The tests in d) to f) shall be repeated with the frequency changed to 5 MHz below the top of the transmit frequency band.
- j) The tests in b) to h) may be performed simultaneously.
- k) The tests in d) to j) shall be repeated with the E-plane of the test signal being horizontal. The frequency of the test signal shall be set to a frequency in the centre of the transmit frequency band. The polarizer of the EUT antenna shall be rotated and adjusted such that its E-plane coincides with the E-plane of the test transmitter. The EUT antenna main beam axis shall be aligned with the main beam axis of the test transmitter precise co-polar peaking of the polarization plane shall be done by observing the cross-polar minimum (fine adjustment).

5.1.1.3.6 Cross-polar radiation pattern - azimuth

The following test procedure shall be performed for each transmit frequency band.

- a) The test arrangement shall be as shown in figure 3 with the EUT connected to the test receiver. A signal proportional to the angular position from the servo mechanism shall be applied to the X-axis and the signal level from the test receiver shall be applied to the Y-axis of the plotter.
- b) The frequency of the test signal shall be set to a frequency in the centre of the transmit frequency band.
- c) The initial E-plane of the test signal radiated by the test transmitter through its antenna shall be vertical. The EUT antenna main beam axis shall be aligned with the main beam axis of the test transmitter. The polarizer of the EUT shall be rotated and adjusted such that its E-plane is orthogonal to the E-plane of the test transmitter. Precise fine adjustment of the polarization plane shall be done by observing the cross-polar minimum.
- d) In order to adjust the X-Y plotter giving the maximum reading on the chart the boresight co-polar receive signal shall be used.
- e) The EUT shall be driven in azimuth to -10° .
- f) The transmit pattern measurement is then obtained by driving the EUT in azimuth from -10° to $+10^\circ$ with the plotter recording the results.
- g) The tests in d) to f) shall be repeated with the frequency changed 5 MHz above the bottom of the transmit frequency band.
- h) The tests in d) to f) shall be repeated with the frequency changed to 5 MHz below the top of the transmit frequency band.
- j) The tests in b) to h) may be performed simultaneously.
- k) The tests in d) to j) shall be repeated with the E-plane of the test signal being horizontal. The frequency of the test signal shall be set to a frequency in the centre of the transmit frequency band. The EUT antenna main beam axis shall be aligned with the main beam axis of the test transmitter. The polarizer of the EUT antenna shall be rotated and adjusted such that its E-plane is orthogonal with the E-plane of the test transmitter. Precise adjustment of the polarization plane shall be done by observing the cross-polar minimum.

5.1.1.3.7 Cross-polar radiation pattern - elevation

The following test procedure shall be performed for each transmit frequency band.

- a) The test arrangement shall be as shown in figure 3 with the EUT connected to the test receiver. A signal proportional to the angular position from the servo mechanism shall be applied to the X-axis and the signal level from the test receiver shall be applied to the Y-axis of the plotter.
- b) the frequency of the test signal shall be set to a frequency in the centre of the transmit frequency band.
- c) The initial E-plane of the test signal radiated by the test transmitter through its antenna shall be vertical. The EUT antenna main beam axis shall be aligned with the main beam axis of the test transmitter. The polarizer of the EUT shall be rotated and adjusted such that its E-plane is orthogonal to the E-plane of the test transmitter. Precise fine adjustment of the polarization plane shall be done by observing the cross-polar minimum.
- d) In order to adjust the X-Y plotter giving the maximum reading on the chart the boresight co-polar receive signal shall be used.
- e) The EUT shall be driven in elevation to -1° .

- f) The transmit pattern measurement is then obtained by driving the EUT in elevation from -1° to $+10^\circ$ with the plotter recording the results.
- g) The tests in d) to f) shall be repeated with the frequency changed 5 MHz above the bottom of the transmit frequency band.
- h) The tests in d) to f) shall be repeated with the frequency changed to 5 MHz below the top of the transmit frequency band.
- j) The tests in b) to h) may be performed simultaneously.
- k) The tests in d) to j) shall be repeated with the E-plane of the test signal being horizontal. The frequency of the test signal shall be set to a frequency in the centre of the transmit frequency band. The EUT antenna main beam axis shall be aligned with the main beam axis of the test transmitter. The polarizer of the EUT antenna shall be rotated and adjusted such that its E-plane coincides with the E-plane of the test transmitter. Precise fine adjustment of the polarization plane shall be done by observing the cross-polar minimum.

5.1.2 Computation of results

The results shall be computed by producing a "mask" to the specified limits with the reference level being equal to the sum of the transmitter output power density and the gain of the antenna at the closest frequency to the frequency at which the power density is measured. This reference shall then be placed on the maximum point of the plot obtained from the transmit radiation pattern measurements at the closest frequency to the frequency at which the power density is measured, so as to ascertain that the off-axis EIRP density is within the mask, and thus conforming to the specification.

5.2 Off-axis spurious radiation

5.2.1 Test method

The tests shall be performed with the EUT comprising the SNG TES up to the antenna flange. The antenna shall be replaced by a dummy load. The interconnections cables between the various units shall be the same types as supplied by the manufacturer. The type of cable used shall be entered in the test report.

The EUT shall be terminated with matched impedance at the terrestrial ports if there is no associated equipment connected to such ports if recommended by the manufacturer in the user documentation.

For frequencies up to 80 MHz the measuring antenna shall have a length equal to the 80 MHz resonant length and shall be matched to the feeder by a suitable transforming device. Measurements with broadband antennas is also possible provided that the test site has been calibrated according to the requirements of CISPR 16-1 [4].

For frequencies between 80 MHz and 1 GHz the measuring antenna shall be a balanced dipole which shall be resonant in length. Measurements with broadband antennas is also possible provided that the test site has been calibrated according to the requirements of CISPR 16-1 [4].

For frequencies above 1 GHz the tests shall be performed according to the procedures a) to c) of subclause 5.2.1.2. The measuring antenna shall be a horn radiator of known gain/frequency characteristics. When used for reception the antenna and any associated amplification system shall have an amplitude/frequency response within ± 2 dB of the combined calibration curves across the measurement frequency range considered for the antenna. The antenna is mounted on a support capable of allowing the antenna to be used in either horizontal or vertical polarization and at the specified height.

5.2.1.1 Up to 1,0 GHz

5.2.1.1.1 Test site

The test shall be performed either in an open area test site, a semi-anechoic chamber or an anechoic chamber. Ambient noise levels shall be at least 6 dB below the applicable unwanted emissions limit.

The open area test site shall be flat, free of overhead wires and nearby reflecting structures, sufficiently large to permit aerial placement at the specified measuring distance and provide adequate separation between aerial, test unit and reflecting structures, according to the specification of CISPR 16-1 [4].

For both the open area test site and the semi-anechoic chamber a metal ground plane shall be inserted on the natural ground plane and it shall extend at least 1 m beyond the perimeter of the EUT at one end and at least 1 m beyond the measurement antenna at the other end.

The distance between the EUT and measuring antenna shall be 10 m. An inverse proportionality factor of 20 dB per decade shall be used to normalize the measured data to the specified distance for determining compliance. Care should be taken in measurement of large test units at 3 m at frequencies near 30 MHz due to near field effects.

5.2.1.1.2 Measuring receivers

Measuring receivers shall conform to the following characteristics:

- the response to a constant amplitude sine wave signal shall remain within ± 1 dB across the frequency range of interest;
- quasi-peak detection shall be used in a -6 dB bandwidth of 120 kHz;
- the receiver shall be operated at more than 1 dB below the compression point during tests/measurements.

5.2.1.1.3 Procedure

- a) The EUT shall be in the carrier-on state transmitting on a frequency in the centre of each transmit frequency band and for each modulation scheme.
- b) The EUT shall be rotated through 360° and, except in an anechoic chamber, the measuring antenna height simultaneously varied from 1 m to 4 m above the ground plane.
- c) All spurious radiation shall be measured and noted in frequency and level.

5.2.1.2 Above 1,0 GHz

The spectrum analyser resolution bandwidth shall be set to the specified measuring bandwidth or as close as possible. If the resolution bandwidth is different from the specified measuring bandwidth, bandwidth correction shall be performed for the noise-like wideband spurious radiation.

The test shall be performed in three stages for both the carrier-off and carrier-on states:

Procedure a): Identification of the significant frequencies of spurious radiation;

Procedure b): Measurement of radiated power levels of identified spurious radiation;

Procedure c): Measurement of conducted spurious radiation radiated through the antenna flange.

5.2.1.2.1 Identification of the significant frequencies of spurious radiation

5.2.1.2.1.1 Test site

The identification of frequencies emitting from the EUT shall be performed in an anechoic chamber, an open area test site or a semi-anechoic chamber with the test antenna close to the EUT and at the same height as the volume centre of the EUT.

5.2.1.2.1.2 Procedure

The following test procedure shall be performed for all transmit frequency bands.

- a) The EUT shall be in the carrier-off state.
- b) The receivers shall scan the frequency band whilst the EUT revolves.
- c) The EUT shall be rotated through 360° and the frequency of any spurious signals noted for further investigation.
- d) The tests in b) to c) shall be repeated with the test antenna being in the opposite polarization.
- e) The tests in b) to d) shall be repeated in the carrier-on state whilst transmitting one modulated carrier at maximum power for each modulation scheme at a frequency at the centre of the transmit frequency band.

5.2.1.2.2 Measurement of radiated power levels of identified spurious radiation

5.2.1.2.2.1 Test site

The measurement of each spurious radiation noted during the test procedure in subclause 5.2.1.2.1.2 shall be performed on a test site that is free from reflecting objects, i.e. either an open-area test site, a semi-anechoic chamber or an anechoic chamber.

5.2.1.2.2.2 Procedure

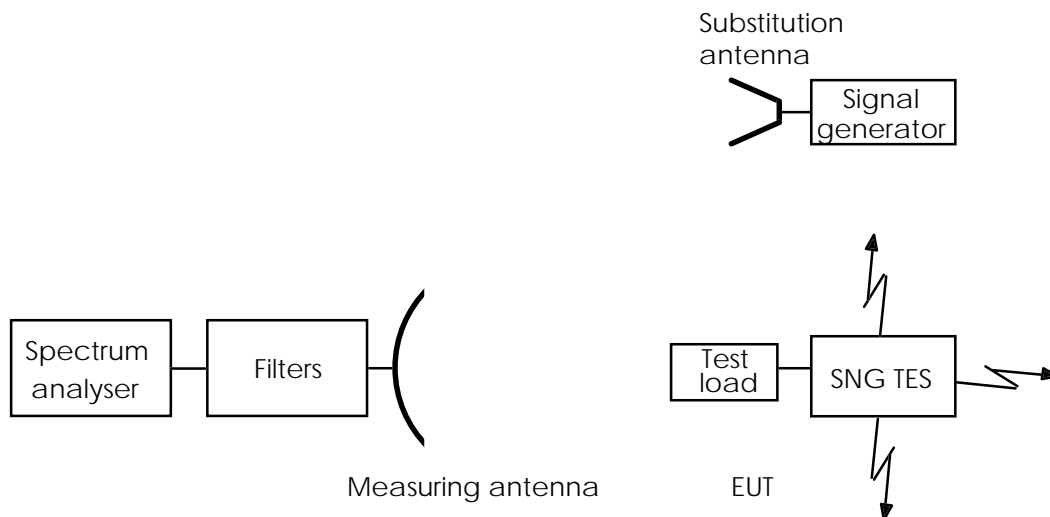

Figure 4: Test arrangement - Spurious radiation measurement above 1,0 GHz

The following test procedure shall be performed for each transmit frequency band.

- a) The test arrangement shall be as shown in figure 4.
- b) The EUT shall be installed such that the various units are placed in their normal operating positions relative to each other. If the test is performed in an open area test site or a semi-anechoic chamber any interconnection cables shall be maintained by non-metallic means at a height between 0,5 m and 1,0 m.

- c) The measuring antenna shall be positioned at a distance from the EUT relevant to the applied test site (e.g. 3, 5, 10 m). The measuring antenna shall be adjusted in height and the EUT rotated, whilst the EUT is in the appropriate carrier condition (transmit power and frequency and modulation scheme), for a maximum response on the associated spectrum analyser at each spurious frequency previously identified, this response level shall be noted. The adjustment in height of the measuring antenna does not apply when an anechoic chamber is being used.
- d) The investigation shall be repeated with the measuring antenna in the opposite polarization and the response level similarly noted.
- e) The EUT shall be replaced by the substitution antenna to which is connected a signal generator. The main beam axes of the measuring and substitution antennas shall be aligned. The distance between these antennas shall be the distance determined under step c).
- f) The substitution and measuring antennas shall be aligned in the polarization which produced the larger response between the EUT and the test antenna in steps c) and d).
- g) The output of the generator shall be adjusted so that the received level is identical to that of the previously noted largest spurious radiation.
- h) The output level of the signal generator shall be noted. The EIRP of the spurious radiation is the sum, in dB, of the signal generator output plus the substitution antenna isotropic gain minus the interconnection cable loss.

5.2.1.2.3 Measurement of conducted spurious radiation at the antenna flange

5.2.1.2.3.1 Test site

There are no requirements for the test site to be used for this test.

5.2.1.2.3.2 Procedure

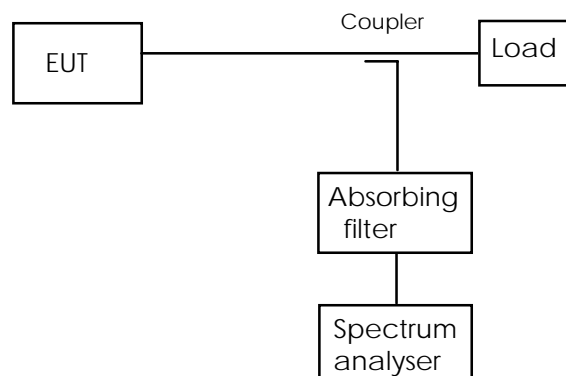

Figure 5: Test arrangement - conducted spurious radiation above the cut-off frequency

The following test procedure shall be performed for each modulation scheme as applicable in the frequency range of interest.

The following test procedure shall be performed for each transmit frequency band.

- a) The test arrangement shall be as shown in figure 5. If in order to protect the spectrum analyser while ensuring the necessary measurement accuracy, particularly close to the carrier, an absorbing filter is used it shall be tuned to the transmit carrier frequency.
- b) The frequency range from the cut-off frequency of the waveguide of the EUT to 40 GHz shall be investigated for spurious radiation whilst in the carrier-on state with one carrier being modulated and at maximum power at a frequency in the centre of the transmit frequency band. For spurious radiations depending on the transmit carrier frequency an investigation may be necessary with the carrier frequency changed to the lower or upper end of the transmit frequency band.

- c) To obtain the off-axis spurious EIRP the maximum measured antenna transmit gain, measured at the frequency of the identified unwanted emission, for off-axis angles greater than 7°, shall be added to the measured power density and any correction and calibration factors summated with the result. If agreed by the manufacturer, it shall be acceptable that the worst case value assumed (i.e. 8 dBi for off-axis angles greater than 7°) is used in place of the maximum off-axis antenna gain at the frequency of the identified unwanted emission.
- d) The test shall be repeated in the carrier-off state.

5.3 On-axis spurious radiation

5.3.1 Test method

5.3.1.1 General

The test shall be performed at the antenna flange.

5.3.1.2 Method of measurement

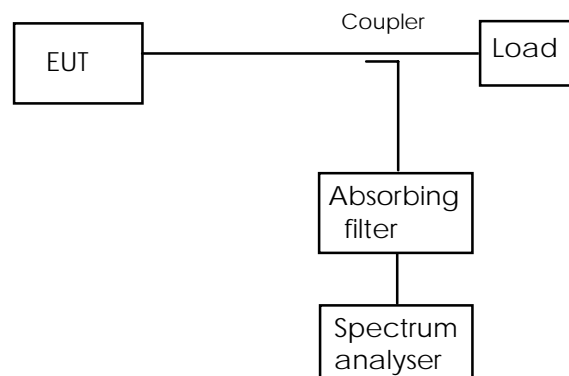

Figure 6: Test arrangement - on-axis spurious radiation measurements

The following test procedure shall be performed for each modulation scheme as appropriate in each transmit frequency band.

- a) The EUT shall be as shown in figure 6. If in order to protect the spectrum analyser while ensuring the necessary measurement accuracy, particularly close to the carrier, an absorbing filter is used it shall be tuned to the transmit carrier frequency.
- b) The EUT shall continuously transmit one modulated carrier centred on a frequency as close to the lower limit of the operating frequency band of the EUT as possible. The transmit frequency band shall be investigated.
- c) The spectrum analyser resolution bandwidth shall be set to the specified measuring bandwidth or as close as possible. If the resolution bandwidth is different from the specified measuring bandwidth, bandwidth correction shall be performed for noise-like wideband spurious radiation.
- d) To obtain the on-axis spurious EIRP, the antenna transmit gain shall be added to any figure obtained in the above measurement and any correction or calibration factor summated with the result. The antenna gain shall be as measured in subclause 5.1.1.2 at the closest frequency to the spurious frequency.
- e) The tests in a) to d) shall be repeated with a transmit frequency in the centre of the transmit frequency band.
- f) The tests in a) to d) shall be repeated with a transmit frequency as close to the upper limit of the transmit frequency band as possible.

5.4 Transmit polarization discrimination

5.4.1 General

For the purposes of this test, the EUT is defined as that part of the SNG TES which comprises the antenna and its flange. The antenna includes the reflector(s), feed, support struts and an enclosure of equal weight/distribution to any electrical equipment normally housed with the feed at the antenna focal point.

5.4.2 Test site

This test shall be performed on either an outdoor far-field test site or compact test range. However, if the near-field scanner technology to convert near-field measurements to far-field results is proven and sufficiently accurate by reference to tests taken in both regions then antenna measurements may be taken in the near field.

Fully automated systems can be used for these tests providing that the results can be proven to be as accurate as if they were done according to the specified method.

5.4.3 Method of measurement



Figure 7: Test arrangement - transmit polarization discrimination

The following test procedure shall be performed for each transmit frequency band.

- a) The test arrangement shall be as shown in figure 7 with the EUT connected to the test receiver. A signal proportional to the angular position from the servo mechanism shall be applied to the X-axis and the signal level from the test receiver shall be applied to the Y-axis of the plotter.
- b) The frequency of the test signal shall be set to a frequency in the centre of the transmit frequency band.
- c) The initial E-plane of the test signal radiated by the test transmitter through its antenna shall be vertical. The EUT antenna main beam axis shall be aligned with the main beam axis of the test transmitter. The polarizer of the EUT antenna shall be rotated and adjusted such that its E-plane coincides with the E-plane of the test transmitter.
- d) The co-polar level on the test receiver shall be noted.
- e) The EUT shall be driven in azimuth and in elevation in opposite directions until the received level in each case drops 1 dB. The lowest and highest angles in azimuth (Az1, Az2) and in elevation (E11, E12) corresponding to this 1 dB co-polar gain reduction shall be noted. The azimuth angle shall be set to 0° and the elevation angle shall be set to 50 % of E11. The EUT shall be driven in azimuth in each direction until the received level has dropped to the level noted in d) minus 1,0 dB. The lowest and highest angle (Az3, Az4) corresponding to this -1 dB co-polar boresight gain reduction at an elevation angle of 50 % of E11 shall be noted. The azimuth angle shall be set to 0° and the elevation angle shall be set to 50 % of E12. The EUT shall be driven in azimuth in each direction until the received level has dropped to the level noted in d) minus 1,0 dB. The lowest and highest angle (Az5, Az6) corresponding to this -1 dB co-polar boresight gain reduction at an elevation angle of 50 % of E12 shall be recorded. The elevation angle and the azimuth angle shall be set to 0°. The test antenna shall be rotated by 90° around its main beam axis for the reception of the cross-polar component.

- f) The EUT shall be driven for the cross-polar component in azimuth from Az1 to Az2 with the X-Y plotter recording the ratio of the level noted in d) and the actual cross-polar level of the test receiver.
- g) The EUT shall be adjusted to an elevation angle of 50 % of EI1. The EUT shall be driven for the cross-polar component in azimuth from Az3 to Az4 with the X-Y plotter recording the ratio of the level noted in d) and the actual cross-polar level of the test receiver.
- h) The EUT shall be adjusted to an elevation angle of 50 % of EI2. The EUT shall be driven for the cross-polar component in azimuth from Az5 to Az6 with the X-Y plotter recording the ratio of the level noted in d) and the actual cross-polar level of the test receiver.
- j) The EUT shall be adjusted to an azimuth angle of 0°. The EUT shall be driven for the cross-polar component in elevation from EI1 to EI2 with the X-Y plotter recording the ratio of the level noted in d) and the actual cross-polar level of the test receiver.
- k) The tests in e) to j) shall be repeated for the 10 dB co-polar reduction (-10 dB contour).
- l) The test antenna shall be rotated by 90° around its main beam axis for reception of the co-polar component. The tests in d) to k) shall be repeated with the frequency changed to 5 MHz above the bottom of the transmit frequency band.
- m) The test antenna shall be rotated by 90° around its main beam axis for reception of the co-polar component. The tests in d) to k) shall be repeated with the frequency changed to 5 MHz below the top of the transmit frequency band.
- n) The tests in b) to m) may be performed simultaneously.
- p) The frequency of the test signal shall be set to a frequency in the centre of the transmit frequency band. The initial E-plane of the test signal radiated by the test transmitter through its antenna shall be horizontal. The EUT antenna main beam axis shall be aligned with the main beam axis of the test transmitter. The polarizer of the EUT antenna shall be rotated and adjusted such that its E-plane coincides with the E-plane of the test transmitter. Precise fine adjustment of the polarization plane shall be done by observing the cross-polar minimum. The tests in d) to n) shall be repeated for this H-plane.

The given test procedure results in two times four plots for each transmit frequency band for every frequency and every plane which show the transmit polarization discrimination in three azimuth cuts and one elevation cut each between the angles corresponding to the -1 dB and -10 dB co-polar contour. Contour plots resulting from fully automated systems are also possible.

5.5 Mechanical (antenna pointing)

5.5.1 Test method

- a) Pointing stability:

As it is considered impracticable to perform the test on pointing stability no test is given. The test methodology described in annex C (informative) may be used to show compliance with the specification for pointing stability.

- b) Pointing accuracy capability:

- 1) The EUT shall be inspected (e.g. with the aid of an inclinometer or laser equipment to ascertain whether fine adjustment facilities are available for the azimuth axis (coarse adjustment is usually provided by the positioning of the means of attachment).
- 2) The adjustment facilities shall be examined to determine both the angular movement possible and the means of arresting that movement.
- 3) The arresting facility shall be examined to determine its permanency.
- 4) The test shall be repeated for the elevation axis.

- c) Polarization angle alignment capability:
 - 1) The adjustment facilities shall be examined to determine both the angular movement possible and the means of arresting that movement.
 - 2) The arresting facility shall be examined to determine its permanency.
- d) Polarization alignment stability:

As it is considered impracticable to perform the test on pointing stability no test is given. The test methodology described in annex C (informative) may be used to show compliance with the specification for pointing stability.

6 Test methods for SNG TES subsystems

The modifications of a SNG TES may consist of the replacement of one or several of the following modules:

- 1) Antenna subsystem.
- 2) High Power Amplifier (HPA).
- 3) Up converter.
- 4) Low Noise Amplifier (LNA).
- 5) Down converter.
- 6) MODulator/DEModulator (modem).

The intermediate and final results of the SNG TES tests before modification shall be made available by the manufacturer.

6.1 Antenna subsystem replacement

This subclause is only applicable to passive antennas.

The following measurements made on the SNG TES before modification shall not be repeated:

- 5.1.1.1 Transmitter output power density;
- 5.2.1.1.3 Procedure for off-axis spurious radiation up to 1,0 GHz;
- 5.2.1.2.1 Identification of the significant frequencies of spurious radiation;
- 5.2.1.2.2 Measurement of radiated power levels of identified spurious radiation (EUT without antenna);
- 5.2.1.2.3 Measurement of conducted spurious radiation at the antenna flange;
- 5.3.1.2 Method of measurement at the antenna flange of on-axis spurious radiation.

The results of these measurements shall be used as those of the unmodified SNG TES and entered in the computation of these subclauses.

Annex A (normative): The TBR Requirements Table (TBR-RT)

Notwithstanding the provisions of the copyright clause related to the text of this TBR, ETSI grants that users of this TBR may freely reproduce the TBR-RT proforma in this annex so that it can be used for its intended purposes and may further publish the completed TBR-RT.

Table A.1: TBR Requirements Table (TBR-RT)

TBR Reference			TBR 030		
No	Category	Reference	TBR-R	Status	Support
1	4.3	4.1	Off-axis EIRP density	M	
2	4.3	4.2	Off-axis spurious radiation	M	
3	4.3	4.3	On-axis spurious radiation	M	
4	4.3	4.4	Transmit antenna polarization discrimination	M	
5	4.3	4.6	Pointing accuracy and stability	M	

Key to columns:

No TBR-RT entry number;

Category Category of essential requirement as per Article 4 of the SES Directive [1];

Reference Clause reference within this TBR of the supporting text for the entry;

TBR-R Title of entry within this TBR-RT;

Status Status of the entry (M = Mandatory, shall be implemented under all circumstances);

Support Does the equipment support the essential requirement of this entry; Y/N.

Annex B (informative): Pointing stability methodology

This test shall be performed by numerical analysis which shall be performed in two stages.

In the first stage the effects of maximum wind speed shall be computed on the outdoor unit using a numerical analysis method (finite elements method by computer) taking into account the intrinsic properties of the materials.

In the second stage the computed loads shall be applied to the structure.

The purpose of the numerical analysis is twofold:

- 1) to show that the fields of force and torque applied to the outdoor unit structure under nominated conditions do not reach the breakpoint limit of any element of the structure;
- 2) to compute equivalent static loads (force and torque) applied to the critical attachment points of the structures, e.g.:
 - reflector - mounting legs fixing point;
 - reflector - struts;
 - LNB - struts.

Numerical analysis and load applications procedure:

- 1) The air related parameters, namely the cinematic viscosity used to calculate drags at the rims of the structure shall be calculated with the standard atmospheric environmental conditions (temperature = 293 K, air pressure = $1,013 \times 10^5$ Pascal).
- 2) The computations needed to derive the field of force and torque and the equivalent static stresses shall be carried out for each of the following variables:
 - elevation angle: maximum and minimum;
 - wind direction: in steps of 45° around the outdoor unit;
 - wind speed: 180 km/h.
- 3) It shall be verified with the simulated results that break point limits are not exceeded for any self-contained element.
- 4) The calculated equivalent static loads shall be applied at any identified critical fixing point of the assembly.
- 5) Whilst the loads are applied the outdoor unit shall be observed and any distortion noted.
- 6) The test report shall contain the following information:
 - the computation method used;
 - description of the test equipment;
 - description of the tests performed;
 - results of the safety margin test;
 - any signs of distortion observed;
 - results of the measurements of the deviation of the antenna position;
 - component deviation with respect to each other.

Annex C (informative): Bibliography

- ETS 300 327 (1994): "Satellite Earth Stations and Systems (SES); Satellite News Gathering (SNG) Transportable Earth Stations (TESs) (13-14/11-12 GHz)".
- ETS 300 456 (1995): "Satellite Earth Stations and Systems (SES); Test methods for Very Small Aperture Terminals (VSATs) operating in the 11/12/14 GHz frequency bands".
- ETR 169 (1995): "Satellite Earth Stations and Systems (SES); Common Technical Regulations (CTRs) in the satellite earth station equipment field".
- EN 55022 (1994): "Limits and methods of measurement of radio disturbance characteristics of information technology equipment".

History

Document history			
August 1996	Public Enquiry	PE 111:	1996-08-05 to 1996-11-29
August 1997	Vote	V 9742:	1997-08-19 to 1997-10-17
December 1997	First Edition		