



TECHNICAL
BASIS for
REGULATION

FINAL DRAFT
pr **TBR 23**

December 1997

Source: ERM

Reference: DTBR/ERM-RP05-002

ICS: 33.020

Key words: Radio, terminal, testing, TFTS, type approval

**Electromagnetic compatibility
and Radio spectrum Matters (ERM);
Terrestrial Flight Telecommunications System (TFTS);
Technical requirements for TFTS**

ETSI

European Telecommunications Standards Institute

ETSI Secretariat

Postal address: F-06921 Sophia Antipolis CEDEX - FRANCE

Office address: 650 Route des Lucioles - Sophia Antipolis - Valbonne - FRANCE

X.400: c=fr, a=atlas, p=etsi, s=secretariat - **Internet:** secretariat@etsi.fr

Tel.: +33 4 92 94 42 00 - Fax: +33 4 93 65 47 16

Copyright Notification: No part may be reproduced except as authorized by written permission. The copyright and the foregoing restriction extend to reproduction in all media.

© European Telecommunications Standards Institute 1997. All rights reserved.

Contents

Foreword	5
Introduction	5
1 Scope	7
2 Normative references	7
3 Definitions, symbols and abbreviations	8
3.1 Definitions	8
3.2 Symbols	8
3.3 Abbreviations	8
4 Requirements	8
4.1 Transmitter power output	9
4.1.1 Requirement	9
4.1.2 Justification for requirement	9
4.2 Transmitter frequency accuracy	9
4.2.1 Requirement	9
4.2.2 Justification for requirement	9
4.3 RF spectrum mask	9
4.3.1 Requirement	9
4.3.2 Justification for requirement	10
4.4 Out of band and spurious emissions	10
4.4.1 Requirement	10
4.4.1.1 Out of band emissions	10
4.4.1.2 Spurious emissions	10
4.4.2 Justification for requirement	10
4.5 Correct decoding of Broadcast Control CHannel (BCCH)	11
4.5.1 Requirement	11
4.5.2 Justification	11
4.6 Correct response to shutdown command from the GS	11
4.6.1 Requirement	11
4.6.2 Justification	11
4.7 AT response to timing and power adjustment commands	11
4.7.1 Requirement	11
4.7.2 Justification	11
5 The TBR test specification	11
5.1 Transmitter power output	12
5.1.1 Test method	12
5.1.2 Test bank characteristics	12
5.1.3 Measurement uncertainty	12
5.2 Transmitter frequency accuracy	13
5.2.1 Test method	13
5.2.2 Test bank characteristics	13
5.2.3 Measurement uncertainty	13
5.3 RF spectrum mask	13
5.3.1 Test method	13
5.3.2 Test bank characteristics	13
5.3.3 Measurement uncertainty	13
5.4 Out of band and spurious emissions	14
5.4.1 Test method	14
5.4.1.1 Out of band emissions	14
5.4.1.2 Spurious emissions	14
5.4.2 Test bank characteristics	14
5.4.3 Measurement uncertainty	15

5.5	Correct decoding of BCCH channel	15
5.5.1	Test method.....	15
5.5.2	Test bank characteristics	15
5.5.3	Measurement uncertainty	15
5.6	Correct response to shutdown command	15
5.6.1	Test method.....	15
5.6.2	Measurement uncertainty	15
5.6.3	Measurement uncertainty	15
5.7	AT response to timing and power adjustment commands	16
5.7.1	Test method.....	16
5.7.1.1	Timing	16
5.7.1.2	Power	16
5.7.2	Test bank characteristics	16
5.7.3	Measurement uncertainty	16
6	Test conditions and facilities	16
6.1	Environmental conditions for tests	16
6.2	Power supply requirements.....	16
6.3	Uncertainty in measurements	16
6.4	Measurements made under continuous or burst modulation.....	16
6.5	Test apparatus	17
6.6	AT testing facilities	17
6.6.1	Direct control of AT	17
6.6.2	Loopback facility	17
6.6.3	Continuous modulation mode.....	18
6.6.3.1	Test signals.....	18
6.6.4	Suppressed modulation mode	18
6.6.5	Standby mode.....	18
6.7	Access to signals	18
Annex A (normative):	TBR Requirements Table (TBR-RT)	20
History		21

Foreword

This final draft Technical Basis for Regulation (TBR) has been produced by the Electromagnetic compatibility and Radio spectrum Matters (ERM) Technical Committee of the European Telecommunications Standards Institute (ETSI), and is now submitted for the Voting phase of the ETSI standards approval procedure.

Introduction

This TBR provides the essential requirements of Article 4e (effective use of the radio frequency spectrum) of Council Directive 91/263/EEC on the approximation of the laws of the Member States concerning telecommunications Terminal Equipment, including the mutual recognition of their conformity. For the Terrestrial Flights Telecommunications System (TFTS) Avionic Termination (AT), Article 4d (protection of the public telecommunications network from harm) has been considered for the TFTS ground station only it has been determined that the AT cannot harm to the public telecommunications network.

Blank page

1 Scope

This Technical Basis for Regulation (TBR) specifies the technical requirements to be provided by terminal equipment of the Terrestrial Flight Telecommunications System (TFTS) capable of, and intended for, connection to a public telecommunication network. The TFTS operates in the frequency spectrum 1 670 MHz to 1 675 MHz (ground to-air) and 1 800 MHz to 1 805 MHz (air to ground). The modulation technique is $\pi/4$ DQPSK. The system is cellular in nature and the available spectrum supports up to 164 radio channels which may be reused between cells. Each radio channel supports four voice telephone circuits with a 9,6 kbit/s voice coding algorithm. TFTS mobile stations are airborne equipment and that they are also subject to a separate certification process for aircraft.

The objective of this TBR is to define the minimum requirements for conformance testing of the TFTS Avionic Termination (AT). This includes testing of the radio interface in terms of Radio Frequency (RF) parameters.

This TBR covers the essential requirements of the Terminal Directive 91/263/EEC [6] Articles 4d and 4e.

This TBR does not include any interworking requirements under Article 4f.

Council Directive 91/263/EEC [6] Articles 4a and 4b [6] are subject to proof of conformity outside of the scope of this TBR and, therefore, are not covered by this TBR.

Telephony for TFTS is not a justified case and therefore there are no requirements on voice quality in relation to Article 4g of Directive 91/263/EEC [6].

There are no technical requirements which are specific to the equipment in terms of Article 4c of Directive 91/263/EEC [6]. Other technical aspects of Electromagnetic compatibility and Radio spectrum Matters (EMC) performance are the subject of normal aircraft equipment certification and are specified in EUROCAE ED-14C [4] (RTCA-DO160C). The applicable test categories are specified in ARINC Characteristic 752 [3].

EN 300 789 [5] constitutes the conformance specification for the radio characteristics of the AT. The set of requirements in EN 300 789 [9] and the set of requirements in this TBR are not necessarily identical.

2 Normative references

This TBR incorporates by dated and undated reference, provisions from other publications. These normative references are cited at the appropriate places in the text and the publications are listed hereafter. For dated references, subsequent amendments to or revisions of any of these publications apply to this TBR only when incorporated in it by amendment or revision. For undated references the latest edition of the publication referred to applies.

- [1] ETS 300 326-2 (1996): "Radio Equipment and Systems (RES); Terrestrial Flight Telephone System (TFTS); Part 2: Speech services, radio interface".
- [2] ETR 028: "Radio Equipment and Systems (RES); Uncertainties in the measurement of mobile radio equipment characteristics".
- [3] ARINC Characteristic 752 (January 1993): "Terrestrial Flight Telephone System (TFTS) Airborne Radio Subsystem".
- [4] EUROCAE ED-14C: "Environmental Conditions and Test Procedures for Airborne Equipment".
- [5] pr EN 300 789 (1997): "Radio Equipment and Systems (RES); Terrestrial Flight Telecommunications System (TFTS); Avionic Termination Radio Testing Specification".
- [6] Council directive of 29 April 1991 on the approximation of the laws of Member States concerning telecommunications terminal equipment, including the mutual recognition of their conformity (91/263/EEC) ("The TTE Directive").

3 Definitions, symbols and abbreviations

3.1 Definitions

For the purposes of this TBR, the following definitions apply:

out-of-band emission: Emission on a frequency or frequencies immediately outside the necessary bandwidth which results from the modulation process, but excluding spurious emissions.

spurious emission: Emission on a frequency or frequencies which are outside the necessary bandwidth and the level of which may be reduced without affecting the corresponding transmission of information. Spurious emissions include harmonic emissions, parasitic emissions, intermodulation products and frequency conversion products, but exclude out-of-band emissions.

unwanted emissions: Consist of spurious emissions and out-of-band emissions.

necessary bandwidth: For a given class of emission, the width of the frequency band which is just sufficient to ensure the transmission of information at the rate and with the quality required under specified conditions.

occupied bandwidth: The width of a frequency band such that, below the lower and above the upper frequency limits, the mean powers emitted are each equal to a specified percentage P/2 of the total mean power of a given emission.

95 % confidence level: 1,96 times the total standard deviation, based on the Student t factor.

continuous modulation mode: See subclause 6.6.3.

suppressed modulation mode: See subclause 6.6.4.

burst mode: Transmission with one or more of the traffic.channels unused.

3.2 Symbols

For the purposes of this TBR, the following symbols apply:

ppm	parts per million
$\pi/4$ DQPSK	$\pi/4$ Differential Quaternary Phase Shift Keying

3.3 Abbreviations

For the purposes of this TBR, the following abbreviations apply:

AT	Avionic Termination
BCCH	Broadcast Control CHannel
BER	Bit Error Ratio
EMC	ElectroMagnetic Compatibility
GS	Ground Station (of the TFTS system)
PRBS	Pseudo Random Bit Sequence
RF	Radio Frequency
TFTS	Terrestrial Flight Telecommunications System
WOW	Weight On Wheels

4 Requirements

This TBR covers the essential requirements of the TTE Directive [6] Articles 4d and 4e.

For guidance, Article 4d refers to the protection of the public telecommunications network from harm, Article 4e refers to the effective use of the radio frequency spectrum.

EN 300 789 [5] provides methods for the radio tests of conformance of the Avionic Termination (AT) to ETS 300 326-2 [1] but contains no tests for the essential requirements of Article 4d of the TTE Directive [6].

4.1 Transmitter power output

4.1.1 Requirement

ETS 300 326-2 [1] subclauses 8.8.2.2.1 and 8.8.2.5.

The nominal mean transmit power shall be +40 dBm (+2, -1 dB) at the antenna port. The lowest value of the mean transmit power shall be 75 ± 2 dB below nominal. The automatic power control shall adjust the output power relative to the nominal mean level in the range +0 to -75 dB in equal steps of 5 dB. The tolerance of each step shall be ± 2 dB.

When Weight On Wheels (WOW) is TRUE, the mean power level shall be reduced to +25 (+4, -3 dB) dBm, also measured at the antenna port.

4.1.2 Justification for requirement

Effective use of the RF spectrum.

The purpose of the test is to verify that the AT output powers both with and without automatic power control action are within the ranges specified in subclause 4.1.1 when measured at the antenna port. This ensures that the AT will not cause interference to other ground stations in the TFTS network by transmitting at too high a power level.

4.2 Transmitter frequency accuracy

4.2.1 Requirement

ETS 300 326-2 [1] subclause 8.8.1.3.1.

The fractional error between the actual transmitted frequency or the centre frequency of the receiver and the nominal frequency shall be less than 2×10^{-7} .

4.2.2 Justification for requirement

Effective use of the RF spectrum.

The purpose of the test is to verify the ability of the AT to transmit the signal on the correct frequency assignment for the channel on which it is transmitting within the tolerances defined in subclause 4.2.1 in order to prevent interference to other TFTS channels.

4.3 RF spectrum mask

4.3.1 Requirement

ETS 300 326-2 [1] subclause 8.8.2.4.

The spectrum mask shall be less than the limits specified in table 1 as the maximum power level at several frequencies above and below the nominal transmit frequency. The frequency offsets shall be measured from the nominal centre frequency, not from the actual value, and power levels are given relative to the transmit power at the nominal frequency.

Table1: Transmitter mask

Frequency offset (kHz)	dB relative to power at centre frequency	Measurement bandwidth (Hz)
±11,3	+1	300
±14,5	-20	300
±15,6	-35	300
±30	-37	300
±60	-49	300
±120	-65	300
±2 500	-70	1 000
±5 000	-75	1 000

4.3.2 Justification for requirement

Effective use of the RF spectrum.

The purpose of the test is to verify the conformance of the AT spectrum mask to the requirements of ETS 300 326-2 [1]. The measurement is necessary to verify that the AT does not transmit power in adjacent channels in excess of the levels specified.

The test shall be carried out in continuous modulation mode only and on channels 1, 82 and 164. The RF mask shall not be measured in burst mode for the reasons given in subclause 6.4.

4.4 Out of band and spurious emissions

4.4.1 Requirement

4.4.1.1 Out of band emissions

ETS 300 326-2 [1] subclause 8.8.2.5.

Out of band emissions from the AT shall be better than -69 dBW/30 kHz at the antenna port, at all frequencies outside the range 1 797,5 MHz to 1 807,5 MHz.

4.4.1.2 Spurious emissions

ETS 300 326-2 [1] subclause 8.8.2.6.

Spurious emissions shall be measured at the antenna port with the transmitter set to full power in suppressed modulation mode and then with the transmitter in standby mode.

The spurious emissions at frequencies between 9 kHz and 1 GHz from the TFTS equipment shall not exceed -58 dBm at the antenna port. The spurious emissions at frequencies between 1 GHz and 12,75 GHz shall not exceed -48 dBm at the antenna port.

This shall be verified by conducted measurements in the band 9 kHz to 12,75 GHz, excluding the AT transmit band from 1 800 MHz to 1 805 MHz, in the suppressed modulation mode.

4.4.2 Justification for requirement

Effective use of the RF spectrum.

The purpose of the tests is to confirm that the AT can operate without emitting harmful out of band or spurious energy.

These tests are necessary to ensure that the AT will not cause unacceptable levels of interference to other channels of the TFTS network or to other radio services in bands adjacent to those allocated to TFTS.

4.5 Correct decoding of Broadcast Control CHannel (BCCH)

4.5.1 Requirement

ETS 300 326-2 [1] subclause 10.11.3.2.1.

The AT shall be capable of decoding the BCCH channel of the transmission from a Ground Station (GS) and shall respect the range limit of that GS.

4.5.2 Justification

Protection of the TFTS network.

The correct operation of the TFTS system is in part dependent on the AT correctly recognizing that it is at, or approaching, the maximum range of the GS with which it is communicating.

4.6 Correct response to shutdown command from the GS

4.6.1 Requirement

If an AT is instructed to shut down by the ground station then it shall do so in the manner specified in ETS 300 326-2 [1] subclause 10.11.5.2.4.

4.6.2 Justification

Protection of the TFTS network.

It is necessary that a malfunctioning AT responds to a shutdown message from the TFTS ground station so that it does not adversely affect the TFTS network.

4.7 AT response to timing and power adjustment commands

4.7.1 Requirement

ETS 300 326-2 [1] subclause 8.10.3.

The AT shall respond as specified to commands from a GS relating to adjustment of the AT transmit power or AT timing.

4.7.2 Justification

Protection of the TFTS network.

An AT transmitting at too high a power or with incorrect timing can cause interference at the GS to signals being received at that GS from other ATs.

5 The TBR test specification

Where parameters or capabilities are subject to manufacturer's declaration and not a specific test, it shall be the manufacturer's responsibility to:

- a) supply a declaration of implementation in which the manufacturer explicitly affirms the implementation in the equipment of certain parameters and/or capabilities;
- b) be prepared to submit upon request supporting design information including circuit designs and software source codes demonstrating the implementation of said capabilities;
- c) be prepared to supply upon request such test results as are practicable including the test methods which support the declaration.

5.1 Transmitter power output

5.1.1 Test method

- a) the AT shall be set in continuous modulation mode;
- b) the transmitter shall be set to channel 82 (1 802,484 848 MHz);
- c) the AT mean output power shall be set to give +40 dBm at the antenna port;
- d) a power meter shall be connected to the antenna port via suitable external power attenuators;
- e) the mean output power shall be calculated as follows:
 - meter reading + power attenuation - any calibration required for the meter and power sensor; and
 - shall be checked versus the range specified in subclause 4.1.1;
- f) the automatic power control shall be set to reduce the output power by 75 dB;
- g) the external power attenuation shall be reduced to give a measurable mean power level at the power meter;
- h) the lowest mean output power shall be calculated as in step e) above and shall be within the range specified in subclause 4.1.1;
- j) the automatic power control shall be set to increase the power in 5 dB steps. The measured output power at each step shall be calculated as in paragraph e) above and its value at each step shall be compared to $(-35 + 5n) \pm 2$ dBm, where n is the step number and steps 0 and 15 correspond to the lowest and highest output powers respectively.

NOTE: It may be necessary to adjust the external power attenuation to take account of the dynamic range of the power meter when increasing the output power in step j).

5.1.2 Test bank characteristics

The test equipment shall consist of a RF power meter (measuring mean power), any associated power sensor, cabling and power attenuators.

The TFTS transmitter shall be connected to the diplexer by the manufacturer-supplied cable and the diplexer receiver port shall be terminated in a 50 Ω load (see figure 1).

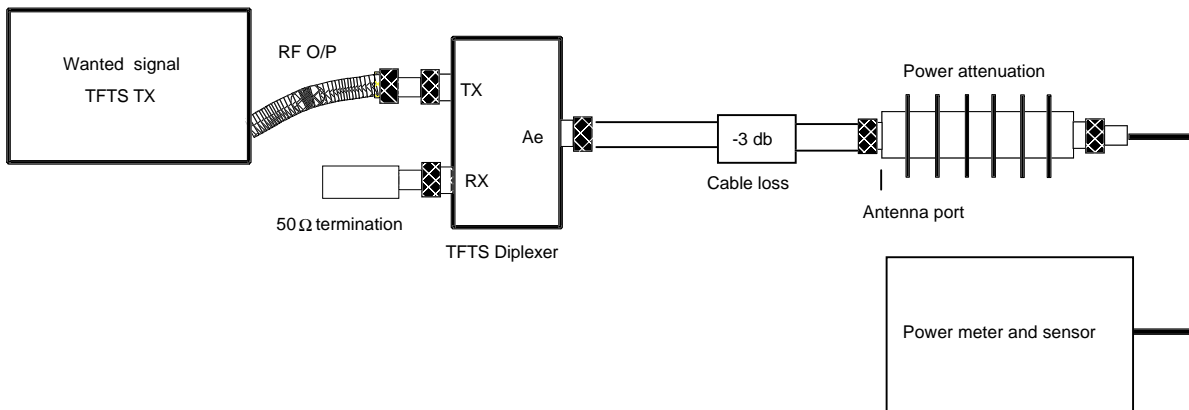

Figure 1: Transmitter power measurement test equipment

5.1.3 Measurement uncertainty

The maximum uncertainty for the measurement shall be ± 1 dB according to ETR 028 [2].

5.2 Transmitter frequency accuracy

5.2.1 Test method

This test method is to measure the short term frequency accuracy of the transmitter. Verification of long term frequency accuracy of an AT shall be by manufacturer's declaration.

- a) the AT shall be set to suppressed modulation mode;
- b) the AT mean output power shall be set to give +40 dBm at the antenna port;
- c) the transmitter shall be set to channel 1 (1 800,030 303 MHz);
- d) the transmitted frequency at the antenna port shall be recorded;
- e) the fractional error shall then be calculated as follows:

$$\text{fractional error} = \frac{|(\text{measured frequency} - \text{nominal channel frequency})|}{\text{nominal channel frequency}}$$

- f) steps c) to e) shall be repeated with the AT transmitter set to channel 82 (1 802,484 848 MHz);
- g) steps c) to e) shall be repeated with the AT transmitter set to channel 164 (1 804,969 696 MHz);
- h) the fractional error in the transmit frequency measured for each channel in steps a) to g) above shall be compared to the maximum admissible value of 2×10^{-7} . For guidance, this corresponds to the measured frequency being contained in the interval $(f_{\text{nom}} - 360)$ Hz to $(f_{\text{nom}} + 360)$ Hz, where f_{nom} is the nominal frequency in Hertz of the channel to which the transmitter is set.

5.2.2 Test bank characteristics

The test equipment shall consist of a frequency meter and appropriate RF attenuation to reduce the transmit power to a level suitable for the meter.

The TFTS transmitter shall be connected to the diplexer by the cable supplied by the manufacturer and the diplexer receiver port shall be terminated in a 50 Ω load.

5.2.3 Measurement uncertainty

The measurement uncertainty depends on the frequency reference used by the frequency counter shall be better than 0,02 ppm.

5.3 RF spectrum mask

5.3.1 Test method

- a) the AT shall be set in continuous modulation mode;
- b) the AT mean output power shall be set to give +40 dBm at the antenna port;
- c) the radio shall be set to transmit on channel 1 (1 800,030 303 MHz);
- d) the signal at the antenna port shall be averaged over at least 20 sweeps on a spectrum analyser with the measurement bandwidth shown in table 2. The mean of the transmit spectrum shall be compared with the values of the transmit mask;
- e) steps c) to d) shall be repeated with the AT set to channel 82 (1 802,484 848 MHz);
- f) steps c) to d) shall be repeated with the AT set to channel 164 (1 804,969 697 MHz).

5.3.2 Test bank characteristics

The test equipment shall consist of a spectrum analyser, a Pseudo Random Bit Sequence (PRBS) generator and RF attenuators to reduce the output power to a suitable level for the analyser. The analyser should be programmed to display the wanted RF mask.

5.3.3 Measurement uncertainty

The uncertainty in the measurement will depend on the relative accuracy of the analyser used. At relative powers of 0 to -50 dB the maximum uncertainty for the measurement shall be ± 2 dB according to ETR 028 [2]. At signal levels below -50 dB the noise floor of the analyser increases the uncertainty which then also depends on the averaging factor used to display the RF mask.

5.4 Out of band and spurious emissions

5.4.1 Test method

5.4.1.1 Out of band emissions

- a) the AT shall be set in continuous modulation mode;
- b) the transmitter shall be set to channel 1 (1 800,030 303 MHz);
- c) the mean output power of the transmitter shall be set to give +40 dBm at the antenna port;
- d) the spectrum analyser shall be swept from 1 697,5 MHz to 1 797,5 MHz;
- e) the level of emissions shall be measured and compared to the maximum admissible value of -69 dBW in 30 kHz. This measurement shall be made in the near vicinity of the transmitted signal and for frequencies where emissions having a level approaching the requirement have been detected;
- f) the main radio shall be set to channel 164 (1 804,969 696 MHz);
- g) the spectrum analyser shall be swept from 1 807,5 MHz to 1907,5 MHz;
- h) the level of emissions shall be measured and compared to the maximum admissible value of -9 dBW in 30 kHz. This measurement shall be made in the near vicinity of the transmitted signal and for frequencies where emissions having a level approaching the requirement have been detected.

5.4.1.2 Spurious emissions

- a) the transmitter shall be set to channel 1 (1 800,030 303 MHz);
- b) the mean output power of the transmitter shall be set to give +40 dBm at the antenna port;
- c) the transmitter shall be set to suppressed modulation mode;
- d) the spectrum analyser shall be swept between 9 kHz and 1 GHz with a measurement bandwidth of 30 kHz;
- e) for each spurious detected, the peak power level shall be measured and compared to the maximum admissible value of -58 dBm;
- f) the spectrum analyser swept from 1 000 MHz to 1 800 MHz and 1 805 MHz to 12,75 GHz with a measurement bandwidth of 30 kHz;
- g) for each spurious detected, the peak power level shall be measured and compared to the maximum admissible value of -48 dBm;
- h) steps d) to g) shall be repeated with the transmitter set to channel 82 (1 802,484 848 MHz);
- j) steps d) to g) shall be repeated with the transmitter set to channel 164 (1 804,969 696 MHz);
- k) the AT shall be set to standby mode;
- l) steps c) to g) shall be repeated, including measurement in the band 1 800 MHz - 1 805 MHz.

5.4.2 Test bank characteristics

A spectrum analyser shall be connected to the antenna terminal of the diplexer via a 50 Ω power attenuator.

The receiver output of diplexer shall be connected to the receiver input of the AT.

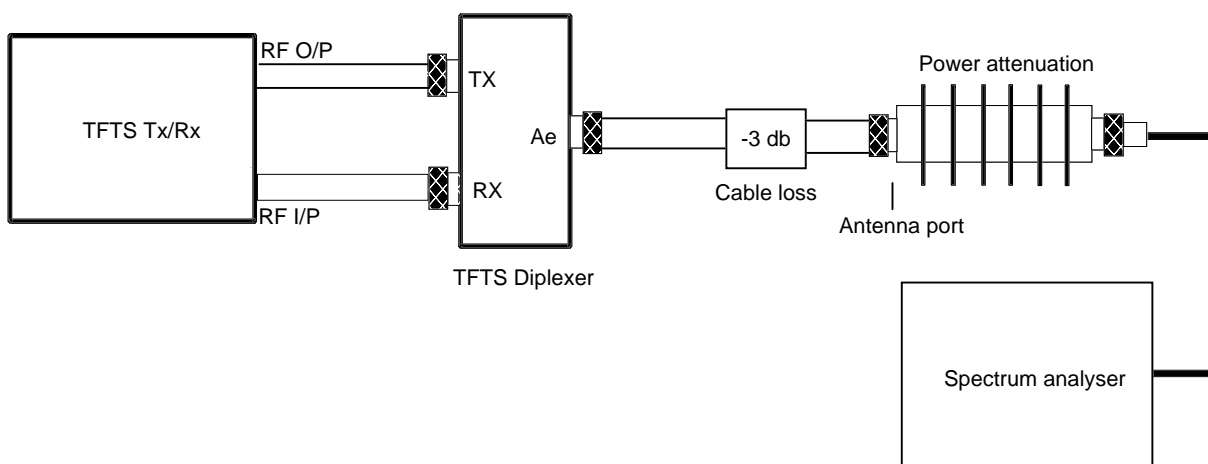

Figure 2: Unwanted emissions measurement equipment

5.4.3 Measurement uncertainty

The typical measurement uncertainty has been calculated as ± 4 dB according to ETR 028 [2].

5.5 Correct decoding of BCCH channel

5.5.1 Test method

The test GS BCCH 5 (D) shall be configured to set the cell radius to a convenient value (for example 100 km).

The transmit timing shall be adjusted so that the timing at the AT gives the appearance of a range to the GSS equal to the cell radius minus 5 km.

The AT shall be configured to establish a connection.

The transmit timing shall be adjusted so that the AT timing gives appearance of a range equal to the cell radius plus 5 km. Some equipments may reject a jump in range in order to protect against false correlations in the presence of noise. This is acceptable and if applicable, the test equipment shall move the range slowly and continuously from one value to the other. The AT shall cease transmitting within 25 s. of reaching cell radius plus 5 km.

5.5.2 Test bank characteristics

The AT under test shall be connected to a test GS through a feeder cable. If necessary, an attenuator may be installed between the units. If this is the case, then the attenuator shall be adjusted to establish a signal level into the AT under test that is nominally 6 dB above sensitivity.

5.5.3 Measurement uncertainty

As the parameter being tested is digital in nature, measurement uncertainty is not applicable. There is an uncertainty in the accuracy of the range measurement, but this is not significant to this test.

5.6 Correct response to shutdown command

5.6.1 Test method

The test GS shall be configured to transmit the shutdown command including the address of the AT under test.

The AT shall cease transmitting upon receipt of the shutdown command.

5.6.2 Measurement uncertainty

The AT under test shall be connected to a test GS through a feeder cable. If necessary, an attenuator may be installed between the units. If this is the case, then the attenuator shall be adjusted to establish a signal level into the AT under test that is nominally 6 dB above sensitivity.

The test GS shall be capable of specific control of the elements of the BCCH (D) in respect of the shutdown parameter.

5.6.3 Measurement uncertainty

As the parameter being tested is digital in nature, measurement uncertainty is not applicable.

5.7 AT response to timing and power adjustment commands

5.7.1 Test method

5.7.1.1 Timing

The attenuator shall be adjusted to establish a signal level into the AT under test that is nominally 6 dB above sensitivity. The AT shall be configured to establish a connection.

The time of arrival of the AT transmitted signal shall be verified at the GS. This shall be achieved by inspection that the GS assesses the timing to be acceptable.

5.7.1.2 Power

The AT shall be configured to establish connection. The attenuator shall be set to establish a power into the AT of the order of -85 dBm.

Either by automatic (by variation of the attenuator setting) or manual means, it shall be verified that the AT responds to power adjustment commands received from the GS on the BCCH.

5.7.2 Test bank characteristics

The AT under test shall be connected to a test GS antenna connector through a feeder cable. A variable attenuator capable of withstanding the power output from the GS and AT shall be installed between the units.

5.7.3 Measurement uncertainty

The measurement uncertainty is not measurable.

6 Test conditions and facilities

6.1 Environmental conditions for tests

- temperature: 15°C to 35°C;
- relative humidity: 20 % to 75 %;
- pressure: 990 mBar to 1 014 mBar.

Testing under other environmental conditions will have been undertaken by manufacturers according to ARINC characteristic 752 [3] and EUROCAE ED-14C [4] and shall not be repeated for this TBR.

6.2 Power supply requirements

The requirements defined in ARINC characteristic 752 [3] shall be met, i.e. 115 V AC (nominal) supply at 400 Hz (nominal) single phase.

6.3 Uncertainty in measurements

All measurements are quoted with a 95 % level of confidence. Measurement uncertainty has been calculated for each test in accordance with ETR 028 [2].

6.4 Measurements made under continuous or burst modulation

The combination of relatively slow power ramping and relaxed adjacent channel performance (-37 dBc at ± 30 kHz from the channel centre frequency) means that the measurement of radio parameters using burst modulation, i.e. with one or more of traffic channels in a radio channel switched off, would not reveal any more detail than would performing the measurement under continuous modulation with all traffic channels filled. In addition, the use of continuous modulation simplifies the test equipment required, e.g. standard spectrum analysers can be used without the need for time gating.

6.5 Test apparatus

The tests require the AT to be set up in various power and frequency configurations which require a suitably interfaced test system to command the AT directly (see subclause 6.6.1).

Certain items of standard test equipment are required. These are given in table 2.

Table 2: Standard test equipment

Item	Description
AT control test software	Means of controlling AT functions without a GS (e.g. RS 232 interface on AT with control command set and ability to read data from the AT).
Spectrum analyser	Sweep 9 kHz to 12,75 GHz, noise floor typically -148 dBm/Hz. Dynamic range at 1,8 GHz to be 80 dB or greater.
Vector spectrum analyser	Operates at 1,8 GHz, noise floor typically -142 dBm/Hz.
RF frequency counter	Capable of measurement at 1,8 GHz and accuracy better than 2×10^{-8} with a suitable external frequency standard input.
Control PC	To interface with AT control test software.
Data error test set	Used to generate 9,6 kbit/s data with a $2^{15}-1$ bit length PRBS with suitable interface to the AT. Capable of integration sufficient to resolve Bit Error Ratios (BERs) down to 10^{-6} . The sequence shall be at least 10^6 bits long.
PRBS generator	Used to generate 9,6 kbit/s data with a $2^{15}-1$ bit length PRBS. The sequence shall be at least 10^6 bits long (not necessary if data error test set can produce second uncorrelated PRBS).
Complex signal generator	Capable of generating $\pi/4$ DQPSK signals at 1,67 GHz modulated with data from data error test set. Phase noise typically -120 dBc/Hz.
RF power meter	Capable of power measurement at 1,8 GHz.
Miscellaneous	130 MHz generator to provide local oscillator for loopback function, 10 MHz reference, RF mixer, 25 W fixed 50 Ω power attenuators, variable 50 Ω attenuators (1 dB and 10 dB steps), RF signal combiners, 50 Ω load.

6.6 AT testing facilities

There are several facilities without which it is difficult to carry out some of the tests on the AT. The implementation of the following would greatly simplify both the tests and the equipment required to carry them out.

6.6.1 Direct control of AT

All of the test methods specified in clause 5 require that the AT is set up in a specified state before the measurements are carried out. The ability to directly control the AT in the initial stages of measuring transmitter and receiver parameters greatly improves the validity of the measurements as the initial state of the AT before the test can be guaranteed. Indirect control of the AT, e.g. influencing the power level transmitted from the AT by changing the attenuation in the radio link, could form part of a full functional conformance test which is beyond the scope of this TBR. To this end, manufacturers should provide a data port through which the AT may be controlled.

6.6.2 Loopback facility

The equipment required for Bit Error Ratio (BER) evaluation may be simplified by the provision of a loopback facility (see figure 3) that bypasses the 9,6 kbit/s signal from the decoder input to encoder output. The encoder-decoder is then excluded from the test. This allows the AT to be tested with 9,6 kbit/s test signals in continuous modulation mode (see subclause 6.6.3).

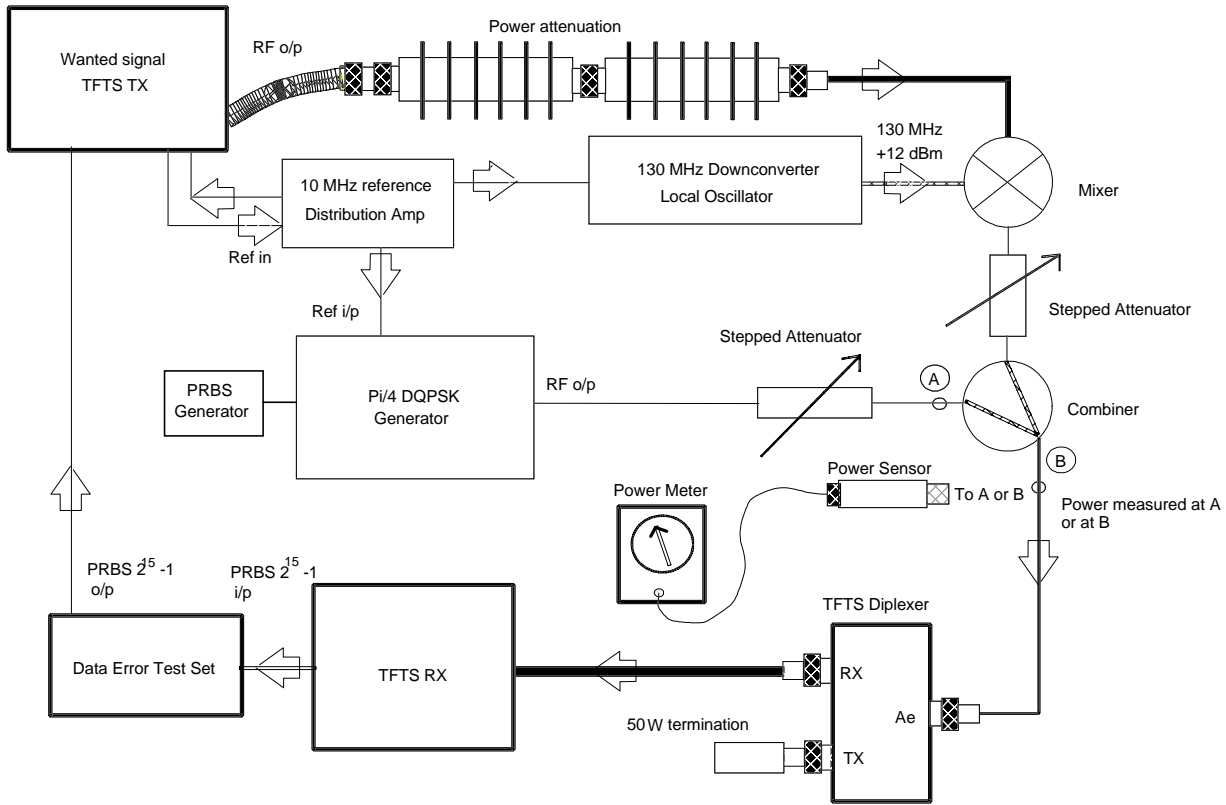

Figure 3: Example of a loopback facility for co-channel and adjacent channel measurements

6.6.3 Continuous modulation mode

The AT should be able to continuously transmit a modulated signal to simulate continuous operation. This signal should be either a 44,2 kbit/s test signal or a composite consisting of a 9,6 kbit/s PRBS in the traffic channels.

6.6.3.1 Test signals

The test signal used to simulate voice traffic shall be a $2^n - 1$ PRBS, where $n = 15$, with a bit rate of 9,6 kbit/s.

6.6.4 Suppressed modulation mode

It shall be possible to operate the AT in a suppressed modulation mode, i.e. transmitting an unmodulated carrier only. This is to simplify the equipment required to perform some of the tests.

6.6.5 Standby mode

It shall be possible to operate the AT in standby mode, i.e. with all time slots switched off.

6.7 Access to signals

The standard interface points of the AT shall be used for testing purposes, see subclause 6.2 of ETS 300 326-2 [1]:

Ua interface: This shall be replaced by an equivalent interface at the AT transceiver RF access points which shall allow for the connection of signals coming from or going to the RF test system. Measurements shall be made at the antenna port, unless stated otherwise, using the antenna feed cable.

This test configuration has assumed a cable loss of 3 dB between the diplexer and the antenna port, see figure 4.

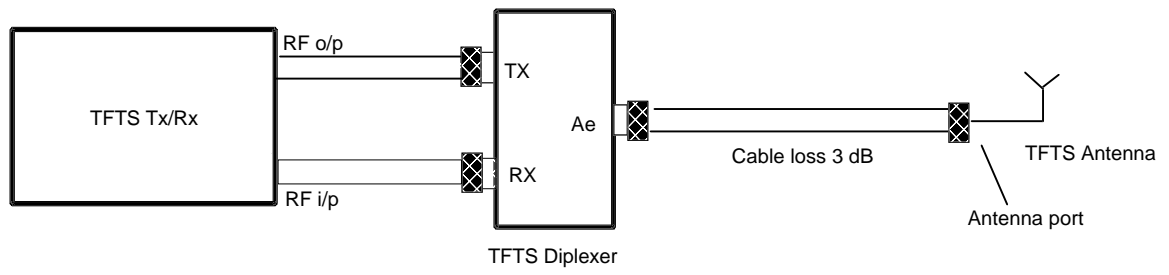

Figure 4: Antenna port interface point

Annex A (normative): TBR Requirements Table (TBR-RT)

TBR Reference:		TBR 23		
Number	Reference	TTE Directive Article	TBR-R	Status
1	4.1.1	4e	Transmitter power output	M
2	4.2.1	4e	Transmitter frequency accuracy	M
3	4.3.1	4e	RF spectrum mask	M
4	4.4.1.1	4e	Out of band emissions	M
5	4.4.1.2	4e	Spurious emissions	M
6	4.5.1	4d, 4e	Decoding of BCCH channel	M
7	4.6.1	4d, 4e	Response to shutdown command from GS	M
8	4.7.1	4d, 4e	Response to timing and power adjustment commands	M

"M" in the STATUS column of the TBR-RT denotes a mandatory requirement.

Users of this specification may freely reproduce the TBR-RT proforma in this annex so that it can be used for its intended purpose and may further publish the completed TBR-RT.

History

Document history			
October 1996	Public Enquiry	PE 116:	1996-10-21 to 1997-02-14
December 1997	Vote	V 9807:	1997-12-16 to 1998-02-13