



**T**ECHNICAL  
**B**ASIS for  
**R**EGULATION

**TBR 10**

July 1999

Third Edition

---

Source: DECT

Reference: RTBR/DECT-000134

ICS: 33.020

**Key words:** DECT, radio, testing, regulation

**Digital Enhanced Cordless Telecommunications (DECT);  
General terminal attachment requirements;  
Telephony applications**

**ETSI**

European Telecommunications Standards Institute

**ETSI Secretariat**

**Postal address:** F-06921 Sophia Antipolis CEDEX - FRANCE

**Office address:** 650 Route des Lucioles - Sophia Antipolis - Valbonne - FRANCE

**Internet:** [secretariat@etsi.fr](mailto:secretariat@etsi.fr) - <http://www.etsi.org>

Tel.: +33 4 92 94 42 00 - Fax: +33 4 93 65 47 16

---

**Copyright Notification:** No part may be reproduced except as authorized by written permission. The copyright and the foregoing restriction extend to reproduction in all media.

© European Telecommunications Standards Institute 1999. All rights reserved.



## Contents

Foreword .....	7
1 Scope .....	9
2 Normative references .....	9
3 Definitions and abbreviations .....	11
3.1 Definitions .....	11
3.2 Abbreviations .....	12
4 Interpretation of the measurement results .....	13
5 General test requirements .....	14
5.1 Test philosophy .....	14
5.1.1 Equipment supporting an ETSI approved profile .....	14
5.1.2 Equipment not supporting an ETSI approved profile .....	15
5.1.3 Applicant's declaration .....	15
5.2 Low noise room .....	16
5.3 Lower Tester (LT) .....	16
5.3.1 Description .....	16
5.3.2 Connections between the EUT and the LT .....	16
5.3.3 Functions and abilities .....	16
5.3.4 Measurement uncertainty .....	16
6 General testing conditions .....	16
6.1 Environment for tests .....	16
6.2 Power supply limitations .....	17
6.3 Power source .....	17
7 Speech and telephony tests .....	17
7.1 Test configurations .....	17
7.1.1 General .....	17
7.1.2 Testing a DECT system .....	17
7.1.3 Testing a separate PP or FP .....	17
7.1.4 Reference FP (ReFP) and Reference PP (RePP) .....	18
7.1.5 Applicability of tests .....	20
7.2 Digital signal level .....	20
7.3 General conditions of test .....	21
7.4 Ideal codec .....	21
7.5 Electro-acoustical equipment .....	22
7.6 Speech coding scheme .....	22
7.6.1 Requirement for speech coding algorithm .....	22
7.6.2 Applicant's declaration on speech coding algorithm .....	22
7.6.3 Requirement for the TAP in the FP .....	22
7.6.4 Applicant's declaration on the TAP in the FP .....	22
7.7 PP sending frequency response .....	22
7.7.1 Requirement .....	22
7.7.2 Method of measurement .....	23
7.8 PP receiving frequency response .....	23
7.8.1 Requirement .....	23
7.8.2 Method of measurement .....	24
7.9 PP loudness rating .....	25
7.9.1 Requirement .....	25
7.9.2 Method of measurement .....	25
7.9.2.1 SLR <sub>H</sub> .....	25
7.9.2.2 RLR <sub>H</sub> .....	25
7.10 User controlled volume control in the PP .....	25

7.10.1	Requirement.....	25
7.10.2	Method of measurement .....	26
7.10.2.1	SLR <sub>H</sub> .....	26
7.10.2.2	RLR <sub>H</sub> .....	26
7.11	PP talker sidetone masking rating .....	26
7.11.1	Requirement.....	26
7.11.2	Method of measurement .....	26
7.12	Listener SideTone (LST).....	26
7.12.1	LSTR requirement.....	26
7.12.2	Protocol requirement for EUTs with declared noise rejection capability .....	26
7.12.3	Method of measurement for LSTR.....	27
7.12.4	Method of measurement for the protocol requirement for EUTs with declared noise rejection capability applying to be approved separately.....	27
7.12.5	Applicant's declaration for the protocol requirement for EUTs applying to be approved as a DECT system .....	27
7.13	Terminal Coupling Loss (TCLw) of a PP .....	28
7.13.1	TCLw requirement.....	28
7.13.2	Protocol requirement.....	28
7.13.3	Method of measurement for TCLw for a PP being approved separately .....	28
7.13.4	Method of measurement for TCLw for a PP being approved as part of a DECT system .....	29
7.13.5	Method of measurement for the protocol requirement for EUTs applying to be approved separately .....	29
7.13.6	Applicant's declaration for the protocol requirement for EUTs applying to be approved as a DECT system .....	29
7.14	FP echo control functions with a 4-wire interface .....	29
7.14.1	Static requirements .....	29
7.14.2	Dynamic requirements .....	29
7.14.2.1	Minimum TCLw.....	29
7.14.2.2	Full TCLw.....	30
7.14.3	Artificial echo loss of a FP with a 4-wire interface .....	30
7.14.3.1	Requirement for artificial echo loss .....	30
7.14.3.2	Requirement for the ability to disable the artificial echo loss .....	30
7.14.3.3	Method of measurement of artificial echo loss .....	30
7.14.3.4	Method of measurement for ability to disable artificial echo loss.....	31
7.14.3.4.1	EUTs being approved as separate items .....	31
7.14.3.4.2	EUTs being approved as a DECT system with a PP having full TCLw.....	31
7.14.4	Echo control device of a FP with a 4-wire interface .....	31
7.14.4.1	Requirement for the echo control device.....	31
7.14.4.2	Requirement for the ability to disable the echo control device .....	31
7.14.4.3	Method of measurement for the echo control device .....	31
7.14.4.4	Method of measurement for the ability to disable the echo control function .....	32
7.14.4.4.1	EUTs being approved as separate items .....	32
7.14.4.4.2	EUTs being approved as a DECT system with a PP having full TCLw.....	32
7.15	Stability loss - fixed geometry .....	32
7.15.1	Requirement.....	32
7.15.2	Method of measurement .....	32
7.16	Stability loss variable geometry.....	32
7.16.1	Requirement.....	32
7.16.2	Method of measurement .....	33
7.17	Sending distortion .....	33
7.17.1	Requirement.....	33
7.17.2	Method of measurement .....	33
7.18	Receiving distortion.....	33
7.18.1	Requirement.....	33

	7.18.2	Method of measurement.....	33
7.19		Side tone distortion.....	34
	7.19.1	Requirement .....	34
	7.19.2	Method of measurement.....	34
7.20		Out of band (sending).....	34
	7.20.1	Requirement .....	34
	7.20.2	Method of measurement.....	34
7.21		Out of band (receiving).....	34
	7.21.1	Requirement .....	34
	7.21.2	Method of measurement.....	35
7.22		Sending noise.....	35
	7.22.1	Requirement .....	35
	7.22.2	Method of measurement.....	35
7.23		Sending noise (narrow band) .....	35
	7.23.1	Requirement .....	35
	7.23.2	Method of measurement.....	35
7.24		Receiving noise .....	35
	7.24.1	Requirement .....	35
	7.24.2	Method of measurement.....	35
7.25		Sampling frequency level (receiving).....	36
	7.25.1	Requirement .....	36
	7.25.2	Method of measurement.....	36
7.26		Acoustic shock .....	36
7.27		DECT network delay.....	36
	7.27.1	Requirement .....	36
	7.27.2	Method of measurement.....	36
7.28		PP delay .....	37
	7.28.1	Requirement .....	37
	7.28.2	Method of measurement.....	38
7.29		FP delay.....	39
	7.29.1	Requirement .....	39
	7.29.2	Method of measurement.....	39
7.30		Echo control at the network side .....	40
	7.30.1	Requirement .....	40
	7.30.2	Method of measurement.....	40
		7.30.2.1 4-wire interface.....	40
		7.30.2.2 Analogue 2-wire interface.....	41
		7.30.2.2.1 Requirement 1 .....	41
		7.30.2.2.2 Requirement 2.....	42
7.31		Variation of gain with input level-sending .....	43
	7.31.1	Requirement .....	43
	7.31.2	Method of measurement.....	43
7.32		Variation of gain with input level- receiving.....	43
	7.32.1	Requirement .....	43
	7.32.2	Method of measurement.....	44
7.33		Additional requirements for DECT systems provided with a 2-wire PSTN interface .....	44
	7.33.1	General .....	44
		7.33.1.1 Polarity independence.....	44
		7.33.1.2 Feed Conditions .....	44
		7.33.1.3 Power supply .....	45
		7.33.1.4 Volume control .....	45
	7.33.2	Speech performance characteristics .....	45
		7.33.2.1 Sensitivity/frequency response.....	45
		7.33.2.2 Sending and Receiving Loudness Ratings (SLR and RLR).....	45
		7.33.2.3 Sidetone .....	45
		7.33.2.4 Distortion .....	45
		7.33.2.5 Linearity (variation of gain with input level).....	45
		7.33.2.6 Noise .....	46
		7.33.2.7 Instability.....	46
		7.33.2.8 Echo Return Loss.....	46
8		Loudspeaking and handsfree telephony .....	46

Annex A (normative):	TBR Requirements Table (TBR-RT) .....	47
Annex B (informative):	Description of the CSS .....	49
B.1	General.....	49
B.2	Test signal.....	49
B.3	Measurement .....	50
B.4	Calculation.....	51
Annex C (normative):	Description of the cross-correlation method.....	53
C.1	Test signal.....	53
C.2	Calculation.....	53
Annex D (informative):	Acoustic shock requirements .....	54
D.1	Continuous signal.....	54
D.2	Peak signal.....	54
Annex E (informative):	Bibliography .....	55
History.....		56

## Foreword

This Technical Basis for Regulation (TBR) has been produced by the Digital Enhanced Cordless Telecommunications (DECT) Project of the European Telecommunications Standards Institute (ETSI).

The present document has been produced by ETSI in response to a mandate from the European Commission issued under Council Directive 83/189/EEC (replaced by 98/34/EC) laying down a procedure for the provision of information in the field of technical standards and regulations.

The present document is intended to become a Harmonized Standard, the reference of which will be published in the Official Journal of the European Communities referencing the Council Directive 98/13/EC [32] on the approximation of the laws of the Member States concerning telecommunications terminal equipment, including the mutual recognition of their conformity ("the TTE Directive").

Technical specifications relevant to the TTE Directive are given in annex A.

<b>Transposition dates</b>	
Date of adoption of this TBR:	25 June 1999
Date of latest announcement of this TBR (doa):	30 September 1999
Date of endorsement of this TBR (dop/e):	31 March 2000
Date of withdrawal of any conflicting National Standard (dow):	31 March 2000

Blank page



## 1 Scope

The present document specifies the technical characteristics particular to telephony applications provided by terminal equipment which is capable of connection to a public telecommunications network and which uses Digital Enhanced Cordless Telecommunications (DECT). The cordless transmissions for such terminal equipment operate within the frequency band 1 880 MHz - 1 900 MHz.

The objective of the present document is to ensure interworking of terminal equipment via the public network.

The requirements in the present document apply in addition to the attachment requirements for the appropriate public network and the TBR for DECT general attachment requirements.

The present document is applicable to simple telephony terminals as well as to the telephony function of multi-function or multi-service terminals.

The present document includes the speech quality and transmission requirements for a 3,1 kHz telephony teleservice.

For each requirement in the present document, a test is given, including measurement methods. The terminal equipment may be stimulated to perform the tests by additional equipment if necessary.

The present document is not applicable to terminal equipment specially designed for the disabled (e.g. with amplification of received speech as an aid for the hard-of-hearing).

DECT comprises two equipment elements, referred to as a Fixed Part (FP) and a Portable Part (PP). The present document is structured to allow type approval of either a) the FP and PP together, or b) the FP and PP as separate items. Where the DECT FP is connected to a PSTN, and there are any peculiarities in the requirements for voice telephony, these shall be accommodated within the FP.

## 2 Normative references

The present document incorporates by dated or undated reference, provisions from other publications. These normative references are cited at the appropriate places in the text and the publications are listed hereafter. For dated references, subsequent amendments to or revisions of any of these publications apply to the present document only when incorporated in it by amendment or revision. For undated references the latest edition of the publication referred to applies.

- [1] EN 300 175-1: "Digital Enhanced Cordless Telecommunications (DECT); Common Interface (CI); Part 1: Overview".
- [2] EN 300 175-2: "Digital Enhanced Cordless Telecommunications (DECT); Common Interface (CI); Part 2: Physical layer (PHL)".
- [3] EN 300 175-3: "Digital Enhanced Cordless Telecommunications (DECT); Common Interface (CI); Part 3: Medium Access Control (MAC) layer".
- [4] EN 300 175-4: "Digital Enhanced Cordless Telecommunications (DECT); Common Interface (CI); Part 4: Data Link Control (DLC) layer".
- [5] EN 300 175-5: "Digital Enhanced Cordless Telecommunications (DECT); Common Interface (CI); Part 5: Network (NWK) layer".
- [6] EN 300 175-6: "Digital Enhanced Cordless Telecommunications (DECT); Common Interface (CI); Part 6: Identities and addressing".
- [7] EN 300 175-7: "Digital Enhanced Cordless Telecommunications (DECT); Common Interface (CI); Part 7: Security features".
- [8] EN 300 175-8: "Digital Enhanced Cordless Telecommunications (DECT); Common Interface (CI); Part 8: Speech coding and transmission".

- [9] ETS 300 111: "Integrated Services Digital Network (ISDN); Telephony 3,1 kHz teleservice; Service description".
- [10] I-ETS 300 245-3: "Integrated Services Digital Network (ISDN); Technical characteristics of telephony terminals; Part 3: Pulse Code Modulation (PCM) A-law, loudspeaking and handsfree telephony".
- [11] TBR 008 (1998): "Integrated Services Digital Network (ISDN); Telephony 3,1 kHz teleservice; Attachment requirements for handset terminals".
- [12] ITU-T Recommendation G.101 (1996): "The transmission plan".
- [13] ITU-T Recommendation G.111 (1993): "Loudness ratings (LRs) in an international connection".
- [14] ITU-T Recommendation G.122 (1993): "Influence of national systems on stability and talker echo in international connections".
- [15] CCITT Recommendation G.223 (1988): "Assumptions for the calculation of noise on hypothetical reference circuits for telephony".
- [16] CCITT Recommendation G.711 (1988): "Pulse code modulation (PCM) of voice frequencies".
- [17] ITU-T Recommendation G.712 (1996): "Transmission performance characteristics of pulse code modulation channels".
- [18] ITU-T Recommendation G.726 (1990): "40, 32, 24, 16 kbit/s adaptive differential pulse code modulation (ADPCM)".
- [19] CCITT Recommendation O.132 (1988): "Quantizing distortion measuring equipment using a sinusoidal test signal".
- [20] ITU-T Recommendation O.133 (1993): "Equipment for measuring the performance of PCM encoders and decoders".
- [21] ITU-T Recommendation P.50 (1993): "Artificial voices".
- [22] ITU-T Recommendation P.51 (1996): "Artificial mouth".
- [23] ITU-T Recommendation P.57 (1996): "Artificial ears".
- [24] ITU-T Recommendation P.64 (1997): "Determination of sensitivity/frequency characteristics of local telephone systems".
- [25] ITU-T Recommendation P.79 (1993): "Calculation of loudness ratings for telephone sets".
- [26] 73/23/EEC: "Council Directive of 19 February 1973 on the harmonization of the laws of the Member States relating to electrical equipment designed for use within certain voltage limits" (Low Voltage Directive).
- [27] ISO 3 (1973): "Preferred numbers - Series of preferred numbers".
- [28] ISO 9614: "Acoustics - Determination of sound power levels of noise sources using sound intensity".
- [29] TBR 038: "Public Switched Telephone Network (PSTN); Attachment requirements for a terminal equipment incorporating an analogue handset function capable of supporting the justified case service when connected to the analogue interface of the PSTN in Europe".

- [30] ETS 300 700: "Digital Enhanced Cordless Telecommunications (DECT); Wireless Relay Station (WRS)".
- [31] TBR 006: "Digital Enhanced Cordless Telecommunications (DECT); General terminal attachment requirements".
- [32] 98/13/EC: "Council Directive of 12 February 1998 on the approximation of the laws of the Member States concerning telecommunications terminal equipment and satellite earth station equipment, including the mutual recognition of their conformity" (Terminal Directive).

### 3 Definitions and abbreviations

#### 3.1 Definitions

For the purposes of the present document, the following definitions apply:

**Acoustic Reference Level (ARL):** The acoustic level that corresponds to a power level of -10 dBm0 at the TAP.

**conducted measurements:** Measurements which are made using a direct connection to the Equipment Under Test (EUT).

**dBPa:** Sound pressure level relative to 1 Pa (no weighting).

**duplex bearer:** Use of two simplex bearers operating in opposite directions on two physical channels. These pairs of channels always use the same radio Frequency (RF) carrier and always use evenly spaced slots (i.e. separated by 0,5 Time Division Multiple Access (TDMA) frame).

**Equipment Under Test (EUT):** Equipment submitted to the test laboratory for type examination.

**fixed geometry PP:** PP in which the electro-acoustic transducers and their associated acoustic components are held in fixed relative positions and/or orientations during all on-line conditions of the PP.

**Fixed Part (DECT Fixed Part) (FP):** Physical grouping that contains all of the elements in the DECT network between the local network and the DECT air interface.

NOTE 1: A DECT fixed part contains the logical elements of at least one fixed radio termination, plus additional implementation specific elements.

**Fixed Radio Termination (FT):** Logical group of functions that contains all of the DECT processes and procedures on the fixed side of the DECT air interface.

NOTE 2: A fixed radio termination only includes elements that are defined in EN 300 175 parts 1 to 8 [1] to [8]. This includes radio transmission elements (layer 1) together with a selection of layer 2 and layer 3 elements.

**Full Slot (SLOT):** One 24th of a TDMA frame which is used to support one physical channel.

**handset echo:** Echo, perceptible by the far-end user, resulting from the coupling between the receive and send directions of the handset, mostly due to acoustic coupling between transducers. It is particularly cumbersome in communications including a satellite and an echo canceller, as the DECT handset echo may be out of range of the echo canceller.

**inter-operability:** Capability of fixed parts and portable parts, that enable a portable part to obtain access to teleservices in more than one location area and/or from more than one operator (more than one service provider).

**Local Echo Loss (LLe):** Sum of the reflections measured at the digital interface of the RePP. It is calculated according to ITU-T Recommendations G.122 [14], annex B4, Trapezoidal rule.

**Lower Tester (LT):** Logical grouping that contains the test equipment, a functionally equivalent DECT PT, a functionally equivalent DECT FT and a test controller.

**network echo:** Echo, perceptible by the DECT user, resulting from reflections in the network. It is mostly due to hybrid impairments at both ends of the communication. The protection consists of an additional echo loss located in the receive path of the DECT system.

**Portable Handset (PHS):** Single physical grouping that contains all of the portable elements that are needed to provide a teleservice to the user.

NOTE 3: Portable handset is a subset of all possible portable parts. This subset includes all physical groupings that combine one portable radio termination plus at least one portable application in a single physical box.

**Portable Part (PP):** Physical grouping that contains all elements between the user and the DECT air interface. Portable Part (PP) is a generic term that may describe one or several physical pieces.

NOTE 4: A portable part is logically divided into one portable termination plus one or more portable applications.

**Portable Radio Termination (PT):** Logical group of functions that contains all of the DECT processes and procedures on the portable side of the DECT air interface.

NOTE 5: A PT only includes elements that are defined in EN 300 175 parts 1 to 8 [1] to [8]. This includes radio transmission elements together with a selection of layer 2 and layer 3 elements.

**public:** Attribute indicating that the application of the so qualified term is used to provide access to a public network for the general public.

NOTE 6: The term does not imply any legal or regulatory aspect, nor does it imply any aspects of ownership.

**Test Access Point (TAP):** Test Access Point is a digital interface with a relative level of 0 dB<sub>r</sub> providing the access to the PCM speech channels in both transmission directions.

**telephony 3,1 kHz teleservice:** Definition for telephony 3,1 kHz teleservice is to be found in ETS 300 111 [9].

NOTE 7: Work is currently being undertaken by ETSI to analyse the mouth-to-ear characteristics of voice communication. The results of this work can have consequences for the essential requirements of the present document.

**test laboratory:** Body which performs testing and is designated to perform 3rd party testing.

**variable geometry PP:** PP that allows the position and/or orientation of its electro-acoustic transducers and their associated acoustic components to be changed during all on-line conditions of the PP.

### 3.2 Abbreviations

For the purposes of the present document, the following abbreviations apply:

ADPCM	Adaptive Differential PCM
ARL	Acoustic Reference Level
BER	Bit Error Ratio
CI	Common Interface
CLRR	Circuit Loudness Rating, Receive
CLRS	Circuit Loudness Rating, Send
CSS	Composite Source Signal
dBm	dB relative to 1 mW
dBm0	The absolute power level in decibels referred to a point of zero relative level
dBr	The relative power level in decibels

DLC	Data Link Control
ERP	Ear Reference Point
EUT	Equipment Under Test
FFT	Fast Fourier Transformation
FP	Fixed Part
FT	Fixed radio Termination
GAP	Generic Access Profile
ISDN	Integrated Services Digital Network
LL <sub>e</sub>	Local Echo loss
L <sub>meST</sub>	Telephone Sidetone Path Loss
LNR	Low Noise Room
LR	Loudness Rating
LRGP	Loudness Rating Guard-ring Position
LST	Listener Sidetone
LSTR	Listener Sidetone Rating
LT	Lower Tester
MAC	Medium Access Control
MRP	Mouth Reference Point
NWK	NetWork
PABX	Private Automatic Branch Exchange
PCM	Pulse Code Modulation
PHL	Physical Layer
PHS	Portable HandSet
PP	Portable Part
PSTN	Public Switched Telephone Network
PT	Portable radio Termination
ReFP	Reference Fixed Part (for speech testing)
RePP	Reference Portable Part (for speech testing)
RF	Radio Frequency
RLR	Receive Loudness Rating
RLR <sub>H</sub>	Receiving Loudness Rating of the Handset
rms	root mean square
SL	Linear input Signal, see CCITT Recommendation G.726 [18]
SLR	Sending Loudness Rating
SLR <sub>H</sub>	Sending Loudness Rating of the Handset
SR	Reconstructed Signal, see CCITT Recommendation G.726 [18]
Ssi(diff)	The difference of the send sensitivities between diffuse and direct sound
Ssi(direct)	The sending sensitivities for the direct sound
STMR	SideTone Masking Rating
TAP	Test Access Point
TCL	Terminal Coupling Loss
TCLw	weighted Terminal Coupling Loss
TDMA	Time Division Multiple Access
TELR	Talker Echo Loudness Rating
WRS	Wireless Relay Station

#### 4 Interpretation of the measurement results

The interpretation of the results recorded in a test report for the measurements described in the present document shall be as follows:

- a) the measured value related to the corresponding limit shall be used to decide whether an equipment meets the minimum requirements of the standard;
- b) the actual measurement uncertainty of the test laboratory carrying out the measurement, for each particular measurement, shall be included in the test report;
- c) the values of the actual measurement uncertainty shall be, for each measurement, equal to or lower than the values in subclause 5.3.4.

## 5 General test requirements

Those functions and procedures which are optional, as indicated directly or indirectly by "if provided", shall be subject to a conformance test if they are implemented. Whether an optional function/procedure has been implemented shall be indicated by the Apparatus Suppliers declaration.

Wireless Relay Stations, WRS, [30], approved according to the TBR for DECT general attachment requirements [31], also belong to telephony applications. Testing according to the present document is however not applicable to a WRS.

NOTE: A WRS conforms to a defined frame multiplexing scheme [30], which provides a transparent digital bit pipe for the user data, and which automatically provides an acceptable upper bound of the incremental delay introduced by a WRS. No more than one hop is allowed. On national basis, multi-hop architectures may be allowed with the agreement of the national authority. See EN 300 175-8 [8] subclause 8.4.1 for modified echo control requirements for multi-hop architectures.

### 5.1 Test philosophy

#### 5.1.1 Equipment supporting an ETSI approved profile

Equipment falling into this category is defined in EN 300 175-1 [1].

In this case, a test equipment capable of emulating a PT or FT that conforms to EN 300 175 parts 1 to 8 [1] to [8] operating an ETSI approved profile corresponding to that supported by the EUT is required. Consequently, each test set-up consists of the test equipment being connected to the EUT, either by a radio link or via an antenna connector, and a call being established. Figures 1 and 2 show the possible test configurations.

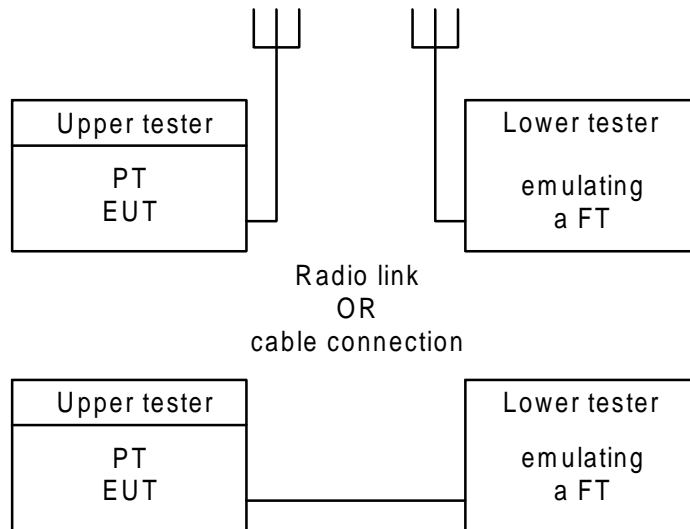
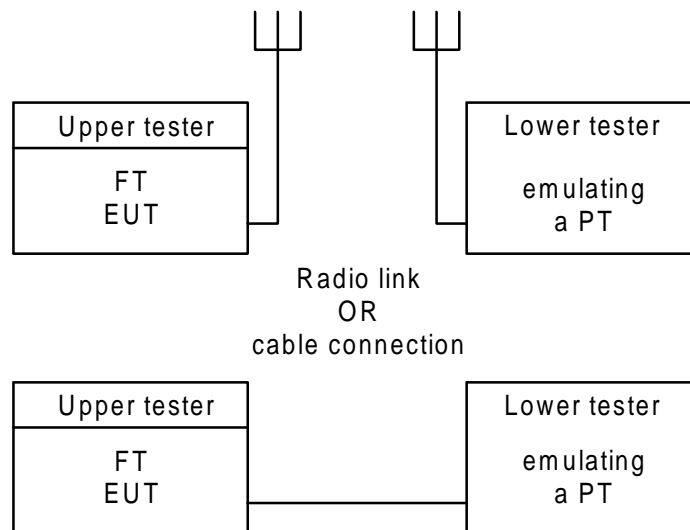

Figure 1: The EUT is a PT



**Figure 2: The EUT is an FT**

Figures 1 and 2 also show that, if available, the EUT can sometimes be connected to the LT by an antenna connector. This is normally preferred in order to minimize the measurement uncertainties.

The Lower Tester (LT) will consist of the general test equipment with the functionality as described in subclause 5.3. Also it will include an RF interface which can emulate the DECT Common Interface.

### **5.1.2 Equipment not supporting an ETSI approved profile**

Equipment falling into this category is defined in EN 300 175-1 [1].

If an LT is available that can establish a speech connection with the EUT and the EUT supports, where required, the <<TERMINAL CAPABILITY>> information element as described in EN 300 175-5 [5], subclause 7.7.41, then approval of an FP and a PP as a separate item is allowed, and the test philosophy described in subclause 5.1.1 shall be applicable.

If an LT is not available that can establish a speech connection with the EUT or the EUT does not support, where required, the <<TERMINAL CAPABILITY>> information element as described in EN 300 175-5 [5], subclause 7.7.41, then the FP and PP shall be approved as a pair. The applicant shall describe to the test authority how a call is established, maintained and released.

However, when a PT or FT is to be tested as a separate item, the applicant shall provide the test authority with a means for establishing, maintaining and releasing a speech connection in order to test the EUT.

### **5.1.3 Applicant's declaration**

Where parameters, capabilities, etc. are subject to applicant's declaration and not a specific test, it will be the applicant's responsibility to:

- a) supply a Declaration of Implementation, in which the Applicant explicitly affirms the implementation in the equipment of certain parameters and capabilities;
- b) be prepared to submit upon request supporting design information, including circuit designs and software source code, demonstrating the implementation of said capabilities;
- c) be prepared to supply upon request such test results as are practicable, including the test methods, which support the declaration.

**NOTE:** This applies also where adaptive volume control methods are provided for noise rejection and/or echo control capabilities which e.g. have to be switched inactive for some of the tests described below and/or where new test methods have to be declared.

## 5.2 Low noise room

Low noise refers to audio sound and not RF radiation.

The test space shall be practically free-field (anechoic) down to a lowest frequency of 275 Hz, and be such that the handset lies totally within the free field volume. This shall be met if deviations from the ideal free field conditions are less than  $\pm 1$  dB. The ambient noise level shall be less than -64 dBPa(A). Measurements made in the low noise room shall satisfy the measurement uncertainty requirements described in subclause 5.3.4.

## 5.3 Lower Tester (LT)

### 5.3.1 Description

The LT is a logical grouping that contains a ReFP, RePP, the measurement equipment and the controller of the DECT testing system. The LT has the job of establishing the speech path, performing calculations (e.g. signal processing) and interacting with the EUT for the various tests. The LT shall implement the mandatory parts of the DECT specification (see part A of the present document) and any ETSI approved profiles.

When testing EUTs that do not support an ETSI approved profile, the LT is not required to have implemented an ETSI approved profile. See subclause 5.1.2.

### 5.3.2 Connections between the EUT and the LT

This is specified in each test case.

### 5.3.3 Functions and abilities

The LT shall include all the functions necessary to perform the tests and measurements as described in the present document according to the measurement uncertainties described in subclause 5.3.4.

### 5.3.4 Measurement uncertainty

The following values of measurement uncertainty (or better) associated with each measurement parameter apply to all of the test cases described in the present document:

- electrical signal power:  $\pm 0,2$  dB for levels  $\geq -50$  dBm;
- electrical signal power:  $\pm 0,4$  dB for levels  $< -50$  dBm;
- sound pressure:  $\pm 0,7$  dB;
- time:  $\pm 5$  %;
- frequency:  $\pm 2$  %.

NOTE: When measuring sampled systems, it is advisable to avoid measuring at multiples of the sampling frequency. A tolerance of  $\pm 2$  % of the frequencies, may be used to avoid this problem, except at 4 kHz where only the -2 % tolerance may be used.

The measurement uncertainty is defined as the combined effects of all sources of errors at a confidence level of at least 95 %.

## 6 General testing conditions

### 6.1 Environment for tests

The following conditions shall apply during all tests:

- ambient temperature:  $+15^{\circ}\text{C}$  to  $+35^{\circ}\text{C}$ ;



- atmospheric pressure: 86 kPa to 106 kPa;
- Relative Humidity (RH): 5 % to 75 % non-condensing.

Except that the tests shall not be performed outside the operating limits for the terminal equipment as stated by the supplier.

## 6.2 Power supply limitations

For apparatus that is directly powered from the mains supply all tests shall be carried out within 5 % of the normal operating voltage.

If apparatus is powered with other means and those means are not supplied as part of the apparatus, e.g. batteries, stabilized power supplies, d.c., etc., all tests shall be carried out within the power supply limit declared by the supplier. If the power supply is a.c. the tests shall be conducted within 4 % of the stated frequency as declared by the supplier.

## 6.3 Power source

The EUT's battery or mains power supply (whichever is appropriate) shall be used throughout the tests.

# 7 Speech and telephony tests

## 7.1 Test configurations

### 7.1.1 General

A DECT system comprises a PP and a FP. As these parts are not always purchased together, it shall be a requirement that either the complete system or each of the two separate parts shall be capable of being tested. However, a PP, together with a reference FP (ReFP), or a FP, together with a reference PP (RePP), can be considered to represent the relevant characteristics of the complete system. ReFP and RePP referred to in the following subclauses, are part of the LT described in subclause 5.3.1.

### 7.1.2 Testing a DECT system

Complete system tests involve the two-way transmission between the acoustic input and output of a PP and a digital TAP reference point of a FP. This situation is the same as in TBR 008 [11], and as far as possible the same testing methods and testing equipment are used. The general test methods described in subclause 7.1.3 are applicable except that the ReFP and the RePP are replaced by a FP or a PP of the DECT system, unless otherwise stated. EUTs supplied as a DECT system shall only be tested and approved as a complete DECT system.

For a DECT system provided with a 2-wire PSTN interface, the system tests also involve the two-way transmission between the acoustic input and output of the PP and the 2-wire interface of the FP.

### 7.1.3 Testing a separate PP or FP

If an LT is available that can establish a speech connection with the EUT and the EUT supports, where required, the <<TERMINAL CAPABILITY>> information element as described in subclause 7.7.41 of EN 300 175-5 [5] then approval of a FP or a PP as a separate item is allowed.

NOTE: Inter-operability between EUTs that are approved separately is only feasible if they use the same profile.

The performance of the PP shall be measured by means of a Reference Fixed Part, (ReFP). The performance of the FP shall be measured by means of a Reference Portable Part (RePP).

The ReFP and RePP shall provide the equivalent of true air interface measurements and therefore shall not contain circuitry which will modify the true air interface speech frequency performance. To meet these requirements, measurements shall be referred to a uniform PCM reference point. The ITU-T

Recommendation G.726 [18] at 32 kbit/s algorithm requires such a uniform interface, although in the case of DECT it may not be physically available.

The transcoding algorithms are specified such that encoding and decoding are symmetrical, i.e. with an encoder and decoder connected in tandem, the "levels" of the digital signals at the uniform PCM input to the encoder and output from the decoder are identical. Once the speech channel signals are in the digital domain they are essentially lossless and hence the level at the air interface can be related to any digital interface.

Ideally, to measure the send signals from the PP at the air interface, a PCM level meter should be connected to the reference decoder uniform PCM output, and to generate receive signals for the PP at the air interface, a PCM signal generator should be connected to the reference encoder uniform PCM input.

A more practical means of measuring the speech channel performance may be achieved by converting the uniform PCM to standard  $\mu$  or A law PCM and then using a standard PCM test set and applying the appropriate correction factor as defined in CCITT Recommendation G.711 [16] and ITU-T Recommendation G.726 [18] at 32 kbit/s, (although this can have a negative effect on some parameters such as distortion).

Two possible general test methods are described here. The first is commonly called the direct digital processing approach. In this approach, the digital bit-stream is operated upon directly (see figure 3).

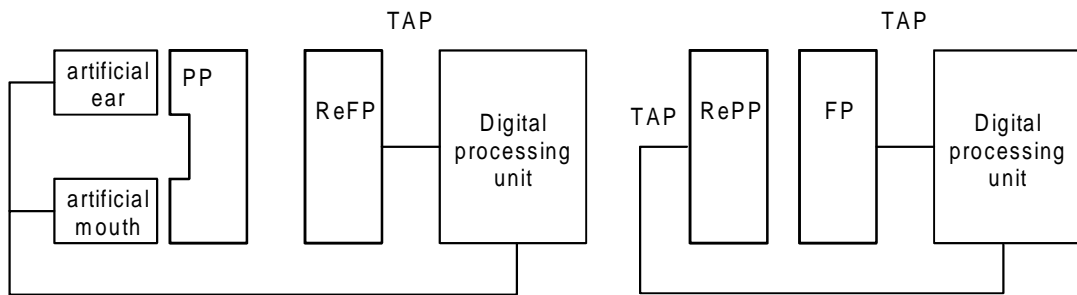

**Figure 3: The direct digital processing approach test configurations for a separate PP and a separate FP**

The second measurement method involves the use of an ideal codec. In this case, a codec is used to convert the digital bit-stream to the equivalent analogue value, so that existing test procedures and existing analogue measuring equipment can be used (see figure 4).

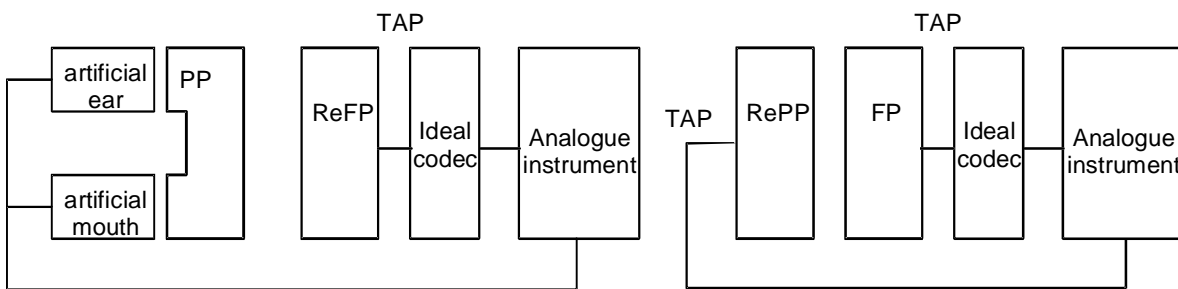

**Figure 4: The ideal codec approach. Test configuration for a separate PP and a separate FP**

For FP EUTs provided with a 2-wire interface, additional tests including the 2-wire interface are defined in subclause 7.33.

**7.1.4 Reference FP (ReFP) and Reference PP (RePP)**

A ReFP and RePP are shown in figures 3 and 4, and they incorporate the specified transcoder algorithm as described in ITU-T Recommendation G.726 [18] at 32 kbit/s.

Both the Reference FP and the Reference PP shall have the ability to loopback the ADPCM signal with a 5 ms delay.

NOTE: This 5 ms delay corresponds to the delay between the receive and transmit timeslots of a duplex bearer.

The reference PP shall have a value of TCLw of  $36 \text{ dB} \pm 2 \text{ dB}$ .

The uniform PCM reference points, points C and D in figure 5, are those designated SR and SL in ITU-T Recommendation G.726 [18] at 32 kbit/s.

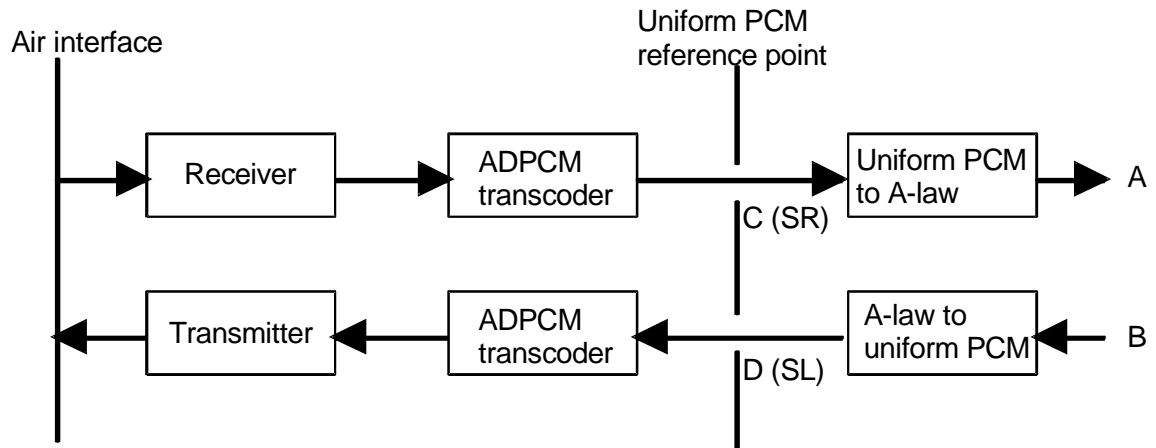

Figure 5: Reference FP and PP

**7.1.5 Applicability of tests**

This subclause, in table 1, indicates whether each test is applicable to the PP, FP or to the system (PP and FP combined). It is intended for information only.

**Table 1**

Subclause Number of Test	Applicable to		
	PP	FP	System
7.6	√	√	√
7.7	√		√
7.8	√		√
7.9	√		√
7.10	√		√
7.11	√		√
7.12	√		√
7.13	√		√
7.14		√	√
7.15	√		√
7.16	√		√
7.17	√		√
7.18	√		√
7.19	√		√
7.20	√		√
7.21	√		√
7.22	√		√
7.23	√		√
7.24	√		√
7.25	√		√
7.26		√	
7.27		√	√
7.28	√		
7.29		√	
7.30		√	√
7.31	√		√
7.32	√		√
7.33		√	√

**7.2 Digital signal level**

The "level" of the digital signal at the uniform companded PCM and ADPCM interfaces are defined in dBm0. A 1 kHz sine wave whose peak signal corresponds with the maximum PCM code is assigned a level of +3,14 dBm0 (CCITT Recommendation G.711 [16]).

The relationship between the PCM encoding law and the audio signal level is defined in CCITT Recommendation G.711 [16]. The theoretical load capacity of ITU-T Recommendation G.726 [18] at 32 kbit/s ADPCM is the same as for A-law PCM.

For sensitivity and loudness rating calculations the nominal voltage assigned to a digital signal is calculated assuming an associated impedance of 600 Ω. Thus 0 dBm0 is equivalent to a voltage of -2,2 dBV.

The digital line interface is a 0 dBr point in accordance with ITU-T Recommendation G.101 [12]. As the various digital transcoding algorithms are essentially loss-less, the relative level is constant over the whole digital path in the PP and the FP except the signal processing described in the present document. Compliance shall be checked by suppliers declaration (see note in subclause 5.1.3).

### 7.3 General conditions of test

Unless otherwise stated, the tests are made under the normal operating conditions specified in subclause 6.2.

The PP or FP under test shall be tested in conjunction with the ReFP or the RePP respectively, separated by some distance, ensuring proper operation of the radio link. In addition, the room shall be a relatively noiseless RF environment such that the normal handshaking between FP and PP is maintained. A connection shall be established and maintained for a two-way speech transmission.

Unless otherwise stated in a particular test, where the PP under test has fixed geometry, the PP shall be placed in the LRGP as described in ITU-T Recommendation P.64 [24], annex C. Where the PP has variable geometry, the front plane of the mouthpiece shall be mounted 15 mm in front of the lip ring and coaxial with the artificial mouth. A PP with variable geometry, having a natural position during on-line conditions shall be regarded as being a fixed geometry PP.

The tests defined in subclauses 7.14 and 7.30, regarding echoes, are defined for steady states. It shall be possible to disable every echo control function implemented in the FP. The applicant shall declare to the test laboratory how this is done.

Unless otherwise stated, if a user-controlled volume control is provided at the PP, the requirements apply for all positions of the volume control, and the compliance tests shall be carried out at the maximum setting of this volume control.

NOTE: ITU-T Recommendation P.64 [24] allows the use of alternative signal sources for measurements of loudness ratings. If such a signal source is used, it is the responsibility of the test laboratory to ensure that the method used can obtain equivalent results.

### 7.4 Ideal codec

The ideal codec approach uses a codec to convert the companded digital bit stream to the equivalent analogue values, so that existing test equipment and procedures may be used. This codec shall be a high quality codec whose characteristics are close to ideal. The codec shall have characteristics such as attenuation/frequency distortion, idle channel noise, quantizing distortion etc. which exceed the reference codec requirements specified in ITU-T Recommendation O.133 [20], clause 4 so as not to mask the corresponding parameters of the apparatus under test. The linear A/D and D/A converters used by the codec shall have at least 14 bit resolution, and the filter response shall lie within the upper and lower limits given in table 2.

**Table 2: Frequency/sensitivity response of an ideal codec**

	Frequency Hz	Loss dB
<b>Lower limit</b>	0	0,0
	80	0,0
	80	-0,25
	3 600	-0,25
	3 600	0,0
	4 000	0,0
<b>Upper limit</b>	100	+40,0
	100	+0,25
	3 000	+0,25
	3 000	+0,9
	3 400	+0,9
	3 400	+40,0

The limit curves shall be determined by straight lines joining successive co-ordinates given in table 2, when the loss is plotted on a linear axis against frequency on a logarithmic axis.

**7.5 Electro-acoustical equipment**

The artificial mouth shall conform to ITU-T Recommendation P.51 [22]. The artificial ear shall conform to ITU-T recommendation P.57 [23].

**7.6 Speech coding scheme**

**7.6.1 Requirement for speech coding algorithm**

The speech coding algorithm shall conform to ITU-T Recommendation G.726 [18] at 32 kbit/s, for 32 kbit/s ADPCM.

The A-law companding and synchronous tandem adjustment may be omitted in FPs with an analogue line interface and in PPs.

NOTE: ITU-T Recommendation G.726 [18] at 32 kbit/s codecs support the use of the voice channel for telefax of group 2 and group 3. For group 3 the data speed, which is automatically negotiated, is in practice typically limited to 9,6 kbit/s.

The ADPCM words comprised in each burst shall be transmitted in chronological order, and with the most significant bit transmitted first within each word.

**7.6.2 Applicant's declaration on speech coding algorithm**

For these highly integrated products, it is not intended to require a PCM interface (uniform or logarithmic) for testing purposes only. Compliance shall be by applicant's declaration (see subclause 5.1.3).

**7.6.3 Requirement for the TAP in the FP**

The TAP of the FP shall be equivalent to the PCM interface of the speech coding algorithm.

**7.6.4 Applicant's declaration on the TAP in the FP**

The applicant shall declare that the TAP of the FP is equivalent to the PCM interface of the speech coding algorithm.

**7.7 PP sending frequency response**

**7.7.1 Requirement**

The sending sensitivity/frequency response (from MRP to the digital interface) shall be within a mask as defined in table 3 and figure 6.

**Table 3: Sending sensitivity-frequency mask**

Frequency (Hz)	Upper limit (dB)	Lower limit (dB)
100	-9	
200	0	
300	0	-14
800	0	-10
2 000	4	-8
3 400	4	-11
4 000	4	
8 000	-13	

NOTE 1: The limits at intermediate frequencies lie on straight lines drawn between the given values on a logarithmic (Hz) - linear (dB) scale.  
NOTE 2: All dB levels are on an arbitrary scale.

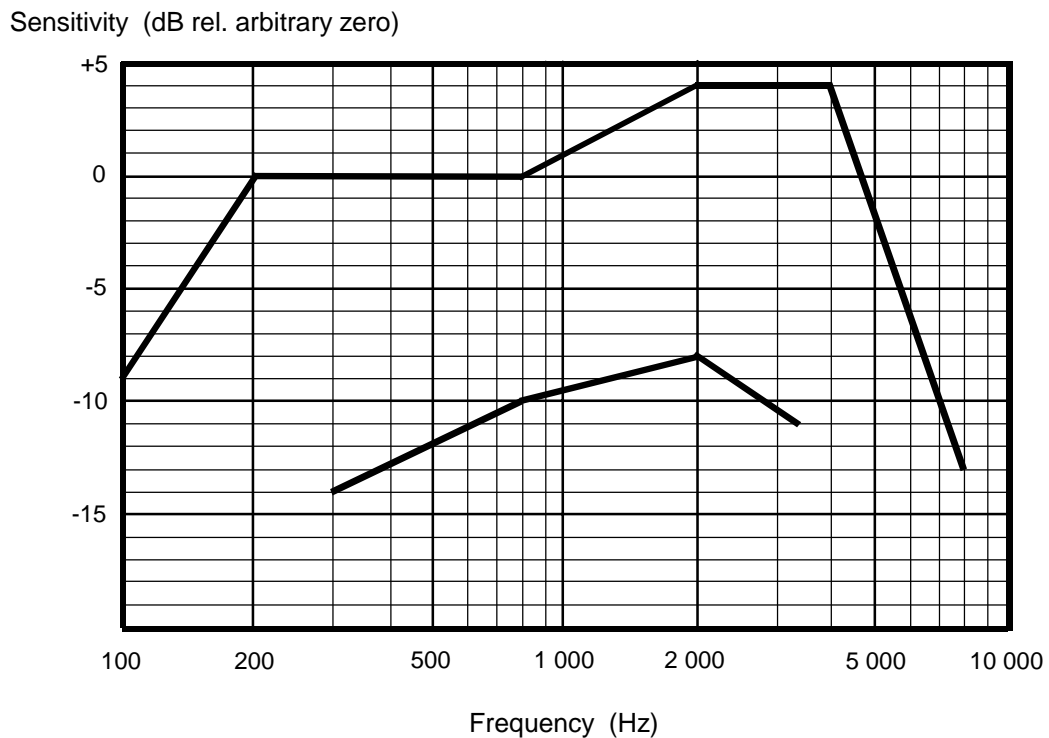

**Figure 6: Sending frequency response tolerance mask**

#### **7.7.2 Method of measurement**

The handset shall be mounted in the LRGP (see ITU-T Recommendation P.64 [24], annex C), and the earpiece sealed to the knife-edge of an artificial ear.

A pure tone signal of -4,7 dBPa shall be applied at the MRP as described in ITU-T Recommendation P.64 [24], using an artificial mouth conforming to ITU-T Recommendation P.51 [22].

A digital measuring instrument, or an ideal codec followed by an analogue level measuring set, shall be connected to point A of the ReFP as shown in figure 5, or to the TAP-reference point of a FP.

Measurements shall be made at one twelfth-octave intervals as given by the R40 series of preferred numbers in ISO 3 [27] for frequencies from 100 Hz to 4 kHz inclusive. At each frequency the level for an input sound pressure of -4,7 dBPa shall be measured.

#### **7.8 PP receiving frequency response**

See EN 300 175-8 [8], subclause 7.1.2.

##### **7.8.1 Requirement**

The receiving sensitivity-frequency response (from the digital interface to the ERP) shall be within a mask as defined in table 4 and shown in figure 7. The proposed receiving frequency response tolerance mask is applicable for all types of couplers (type 1, 3.2., 3.3, 3.4).

**Table 4: Receiving sensitivity-frequency mask**

Frequency (Hz)	Upper limit (dB)	Lower limit (dB)
100	-10	
200	2	
300		-9
1 000		-7
3 400		-12
4 000	2	
8 000	-15	

NOTE 1: The limits at intermediate frequencies lie on a straight line drawn between the given values on a logarithmic (Hz) - linear (dB) scale.  
NOTE 2: All dB levels are on an arbitrary scale.

Sensitivity (dB rel. arbitrary zero)

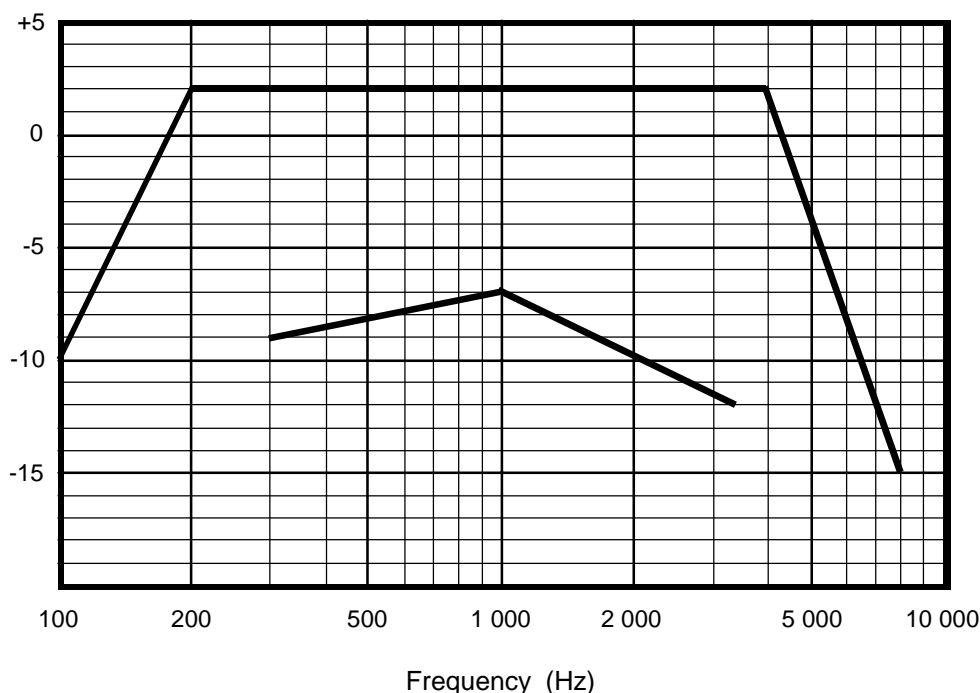

**Figure 7: Receiving frequency response tolerance mask**

**7.8.2 Method of measurement**

A digital signal generator, or an analogue signal generator followed by an ideal codec, shall be connected to point B of the ReFP as shown in figure 5, and the level shall be adjusted to produce a level of -16 dBm0 at the uniform PCM reference point.

The receiving sensitivity/frequency response shall be determined as described in clause 9 of ITU-T Recommendation P.64 [24] and by using the procedure described in clause 11 of the Recommendation. The sound pressure is measured at the fundamental frequency of the stimulus. The results are expressed in dBPa/V.

Measurements shall be made at 1/12 octave intervals at the preferred frequencies given by the R40 series preferred numbers in ISO 3 [27] for frequencies from 100 kHz to 8 kHz.



## 7.9 PP loudness rating

### 7.9.1 Requirement

The nominal values are: Sending Loudness Rating ( $SLR_H$ ) = 7 dB and Receiving Loudness Rating ( $RLR_H$ ) = 3 dB. The  $SLR_H$  shall be 7 dB  $\pm$  3,5 dB. The  $RLR_H$  shall be 3 dB  $\pm$  3,5 dB.

### 7.9.2 Method of measurement

#### 7.9.2.1 $SLR_H$

To determine the  $SLR_H$ , the sending sensitivity shall be measured as described in subclause 7.7.2 at each of the 14 frequencies given in table 1 of ITU-T Recommendation P.79 [25], bands 4 to 17.

The sensitivity shall be expressed in terms of dBV/Pa and the SLR shall be calculated according to ITU-T Recommendation P.79 [25], formula 2.1, over bands 4 to 17, using  $m = 0,175$  and the sending weighting factors from ITU-T Recommendation P.79 [25], table 1.

#### 7.9.2.2 $RLR_H$

To determine the  $RLR_H$ , the receiving sensitivity shall be measured as described in subclause 7.8.2 at each of the 14 frequencies listed in table 1 of ITU-T Recommendation P.79 [25], bands 4-17.

The sensitivity shall be expressed in terms of dBPa/V and the RLR shall be calculated according to ITU-T Recommendation P.79 [25], formula 2.1, over bands 4 to 17, using  $m = 0,175$  and the receiving weighting factors from table 1 of this Recommendation.

The artificial ear sensitivity shall be corrected using the real ear correction of table 2 of ITU-T Recommendation P.79 [25].

## 7.10 User controlled volume control in the PP

### 7.10.1 Requirement

A user-controlled volume control shall be provided in all PP equipment, except where that incorporates an adaptive volume control in the PP.

When adjusting the volume control from nominal to maximum setting, the decrease in  $RLR_H$  shall be not less than 6 dB.

Where user controlled volume control is provided instead of an adaptive volume control, adjust the volume control to the setting (nominal) where the RLR is closest to its nominal value. At this setting the  $RLR_H$  and  $SLR_H$  shall simultaneously meet the values given in subclause 7.9.1, including the tolerances. A "joint acting" volume control is where the PP can simultaneously change the values of SLR and RLR in opposite directions.

The  $RLR_H$  and  $SLR_H$  shall not exceed the limits given in tables 5 and 6.

**Table 5: Absolute limits for "joint-acting" volume control**

Volume setting	Maximum	Minimum
$RLR_H$	-13 dB	19 dB
$SLR_H$	17 dB	3 dB
NOTE: Minimum setting: The setting where the RLR has its maximum value.		

**Table 6: Absolute limits for a receiving volume control**

Volume setting	Maximum	Minimum
RLR <sub>H</sub>	-13 dB	19 dB
NOTE: Minimum setting: The setting where the RLR has its maximum value.		

**7.10.2 Method of measurement**

**7.10.2.1 SLR<sub>H</sub>**

The method of measurement and test conditions shall be as laid down in subclause 7.9.2.1.

**7.10.2.2 RLR<sub>H</sub>**

The method of measurement and test conditions shall be as laid down in subclause 7.9.2.2.

**7.11 PP talker sidetone masking rating**

**7.11.1 Requirement**

The sidetone path shall be implemented in the PP.

The nominal value of the SideTone Masking Rating (STMR) shall be 13 dB. The value of the STMR shall be 10 dB - 18 dB referred to nominal values of SLR<sub>H</sub> and RLR<sub>H</sub> (SLR<sub>H</sub> = 7 dB and RLR<sub>H</sub> = 3 dB).

**7.11.2 Method of measurement**

For the test the digital input in the receiving direction shall be driven by a signal corresponding to PCM decoder value number 1.

Where a user controlled volume control is provided, the measurements shall be carried out at a setting which shall be as close as possible to the nominal value of the RLR (RLR = 3 dB).

The handset shall be mounted in the LRGP and the earpiece shall be sealed to the knife-edge of the artificial ear. A pure tone signal of -4,7 dBPa shall be applied at the mouth reference point. For each frequency given in ITU-T Recommendation P.79 [25] table 3, bands 1 to 20, the sound pressure in the artificial ear shall be measured.

The sidetone path loss  $L_{meST}$  as expressed in dB and the STMR (in dB) shall be calculated from the formula 2.1 of ITU-T Recommendation P.79 [25], using  $m = 0,225$  and the weighting factors in table 3 of ITU-T Recommendation P.79 [25].

**7.12 Listener SideTone (LST)**

**7.12.1 LSTR requirement**

The value of the LSTR shall not be less than 10 dB referred to the nominal values of SLR<sub>H</sub> and RLR<sub>H</sub>.

For PPs with noise rejection capability as declared by the applicant, the value of the LSTR shall not be less than 15 dB referred to the nominal values of SLR<sub>H</sub> and RLR<sub>H</sub>.

Alternatively the value of the weighted average D of the difference of the send sensitivities between diffuse and direct sound shall be measured and shall not be less then -5 dB and with noise rejection the weighted average D shall not be less then +0 dB. One of both alternatives shall be declared by the applicant.

**7.12.2 Protocol requirement for EUTs with declared noise rejection capability**

The FP shall know whether or not the PP has implemented the noise rejection capability before or at call set-up.

### 7.12.3 Method of measurement for LSTR

A diffuse sound field of pink noise shall be calibrated in the absence of any local obstacles. The averaged field shall be uniform to within  $\pm 3$  dB within a radius of 0,15 m of the MRP, when measured in one-third octave bands from 100 Hz to 8 kHz (bands 1 to 20).

NOTE 1: The pressure intensity index as defined in ISO 9614 [28] may prove to be a suitable method for assessing the diffuse field.

NOTE 2: Where more than one loudspeaker is used to produce the desired sound field, the loudspeakers may require to be fed with non-coherent electrical signals to eliminate standing waves and other interference effects.

Where a user controlled volume control is provided, the measurements shall be carried out at a setting which shall be as close as possible to the nominal value of the RLR (RLR = 3 dB).

A calibrated half-inch microphone shall be mounted at MRP. The sound field shall be measured in 1/3 octave bands. The power density spectrum shall be band limited "pink noise" (100 Hz to 8 kHz) and the level shall be adjusted to -24 dBPa(A). The tolerance on this level shall be  $\pm 1$  dB.

The artificial mouth and ear shall be placed in the correct position relative to MRP, the handset shall be mounted at LRGP and the earpiece shall be sealed to the knife-edge of the artificial ear.

NOTE 3: It is important to mount the handset as tight as possible to the knife edge of the artificial ear to eliminate the influence of any ear-cap leakage in the range of 100 Hz to 300 Hz as much as possible as mentioned in ITU-T Recommendation G.111 [13].

Measurements shall be made in one-third octave bands for the 20 bands centred at 100 Hz to 8 kHz (bands 1 to 20). For each band the sound pressure in the artificial ear shall be measured by connecting a suitable measuring set to the artificial ear.

The listener sidetone path loss shall be expressed in dB and the LSTR shall be calculated from the ITU-T Recommendation P.79 [25] formula 2.1, using  $m = 0,225$  and the weighting factors in table 3 of the Recommendation.

For the weighted average D of the difference of the send sensitivities between diffuse and direct sound the diffuse sound sensitivities measured as specified above shall be used for the calculation as  $S_{si}(\text{diff})$  at 14 bands from 200 Hz to 4 kHz. The sending sensitivities for the direct sound  $S_{si}(\text{direct})$  shall be measured according to subclause 7.7.2, but at one-third octave bands for 14 bands centred at 200 Hz to 4 kHz with the test signal pink noise as specified above. D is computed with  $S_{si}(\text{diff})$  and  $S_{si}(\text{direct})$  from the ITU-T Recommendation P.79 [25] formulas E-3 and E-2 and the coefficients  $K_i$  in table E.1/P.79.

### 7.12.4 Method of measurement for the protocol requirement for EUTs with declared noise rejection capability applying to be approved separately

Subclause 7.1.3 clarifies which EUTs are applicable to this subclause:

- a) The test personnel shall make a call from the PP including the relevant message that includes the <<TERMINAL CAPABILITY>> information element. If the EUT conforms to an ETSI defined profile, the relevant message defined by this profile shall be used;
- b) the LT shall verify that the <<TERMINAL CAPABILITY>> information element is included in the relevant message and that it indicates correctly whether the PP ambient noise rejection capability has been implemented (see EN 300 175-5 [5], subclause 7.7.41).

### 7.12.5 Applicant's declaration for the protocol requirement for EUTs applying to be approved as a DECT system

Subclause 7.1.2 clarifies which EUTs are applicable to this subclause.

The applicant shall declare one of the following:

- 1) all PPs in the DECT system have identical noise rejection capability and this is known at all FPs; or
- 2) PPs indicate to the FP at call set-up whether they have implemented the noise rejection capability by some protocol means that the FP understands.

### 7.13 Terminal Coupling Loss (TCLw) of a PP

#### 7.13.1 TCLw requirement

The weighted Terminal Coupling Loss (TCLw) defined from the PP digital input to the PP digital output shall meet one of the following options:

- a)  $TCLw > 46$  dB at nominal setting of the volume control corrected to the nominal values of  $RLR_H$  and  $SLR_H$ . For all positions of volume control the TCLw shall not be less than 35 dB;

NOTE 1: This is the recommended option.

- b)  $TCLw > 34$  dB.

NOTE 2: Since there is no statement for option b) on volume control settings, the conditions in the 5<sup>th</sup> paragraph of subclause 7.3 apply.

If the PP is designed to meet option a), this option shall be declared by the applicant.

#### 7.13.2 Protocol requirement

The FP shall know if TCLw option a) has been implemented in the PP.

#### 7.13.3 Method of measurement for TCLw for a PP being approved separately

The PP shall be suspended in free air:

- a) A digital signal generator, or an analogue signal generator followed by an ideal codec, shall be connected to point B of the ReFP as shown in figure 5;
- b) the signal generator shall be set to provide a signal level of -10 dBm<sub>0</sub> at the uniform PCM point D of figure 5;
- c) the PP shall be suspended in free air in a low noise room (see subclause 5.2) in such a way that the inherent mechanical coupling of the handset shall not be affected;
- d) the level at the uniform PCM reference point, point C of figure 5, shall be evaluated using the level meter for one twelfth-octave intervals as given by the R40 series of preferred numbers in ISO 3 [27] for frequencies 300 Hz to 3 350 Hz;
- e) the TCLw, shall be calculated according to ITU-T Recommendation G.122 [14], annex B4, Trapezoidal rule;
- f) for the option a) in subclause 7.13.1, TCLw requirement, the results of the measurements of Terminal Coupling Loss (TCL) shall be corrected by the sending noise if it is requested by the apparatus supplier. In this case two alternative methods are applicable:
  - 1) for every 1/12th octave band the sending noise shall be measured without psophometric weighting and then power subtracted from the measured TCL value;
  - 2) the TCLw shall be calculated as a power integration in accordance to the equation in ITU-T Recommendation G.122 [14], subclause 4.2. The sending noise shall be measured without psophometric weighting and power subtracted from every measured TCL value.

#### **7.13.4 Method of measurement for TCLw for a PP being approved as part of a DECT system**

- a) Disable any artificial echo loss or echo control device;
- b) A digital signal generator, or an analogue signal generator followed by an ideal codec, shall be connected to the TAP-reference point of the FP;
- c) b), c), d) and e) in subclause 7.13.3 are repeated.

#### **7.13.5 Method of measurement for the protocol requirement for EUTs applying to be approved separately**

Subclause 7.1.3 clarifies which EUTs are applicable to this subclause. This requirement does not apply if the PP implements minimum TCLw (option b)):

- a) the test personnel shall make a call from the PP including the relevant message that includes the <<TERMINAL CAPABILITY>> information element. If the EUT conforms to an ETSI defined profile, the relevant message defined by this profile shall be used;
- b) the LT shall verify that the <<TERMINAL CAPABILITY>> information element is included in the relevant message and that it indicates correctly whether full TCLw (option a)) has been implemented (see EN 300 175-5 [5], subclause 7.7.41).

#### **7.13.6 Applicant's declaration for the protocol requirement for EUTs applying to be approved as a DECT system**

Subclause 7.1.3 clarifies which EUTs are applicable to this subclause. This requirement does not apply if the PP implements minimum TCLw (option b)).

The applicant shall declare one of the following:

- 1) all PPs in the DECT system have full TCLw implemented and this is known at all FPs; or
- 2) PPs indicate to the FP at call set-up whether they have implemented full TCLw by some protocol means that the FP understands.

### **7.14 FP echo control functions with a 4-wire interface**

#### **7.14.1 Static requirements**

If the EUT (FP) is part of a DECT System (see subclause 7.1.2) where the PP implements minimum TCLw (see subclause 7.13) or the EUT is being approved as a separate item (see subclause 7.1.3) then the EUT shall implement one of the two following alternatives:

- a) artificial echo loss (see subclause 7.14.3);
- b) echo control device (see subclause 7.14.4).

However, if the EUT (FP) is being approved as part of a DECT System (see subclause 7.1.2) where the PP always implements full TCLw then artificial echo loss and an echo control device shall not be implemented or shall be disabled and the requirements in subclauses 7.14.3 and 7.14.4 do not apply.

#### **7.14.2 Dynamic requirements**

##### **7.14.2.1 Minimum TCLw**

If the FP receives no information concerning the TCLw value of the PP, the FP shall default to the assumption that the PP fulfils option b) of subclause 7.13.1 and it shall enable either an artificial echo loss or an echo control device. Routing information as described in EN 300 175-8 [8], subclause 7.4.1.2 shall not be available during the test.

NOTE: Installed DECT equipment may disable the functions a) or b) e.g. internal calls, local calls or non-speech services as described in EN 300 175-8 [8], subclause 7.4.1.2.

### 7.14.2.2 Full TCLw

For FPs that are approved separately, then receipt of the <<TERMINAL CAPABILITY>> information element indicating full TCLw shall disable any artificial echo loss or echo control device.

For FPs that are being approved as part of a DECT System with PPs in the system implementing both Minimum TCLw and full TCLw then the FP shall, on receipt of a full TCLw indication message, disable any artificial echo loss or echo control device.

### 7.14.3 Artificial echo loss of a FP with a 4-wire interface

#### 7.14.3.1 Requirement for artificial echo loss

An artificial echo path shall be implemented into the FP between the line input and the line output, as shown in figure 8. The loss of that echo path shall be  $24 \text{ dB} \pm 2 \text{ dB}$ .

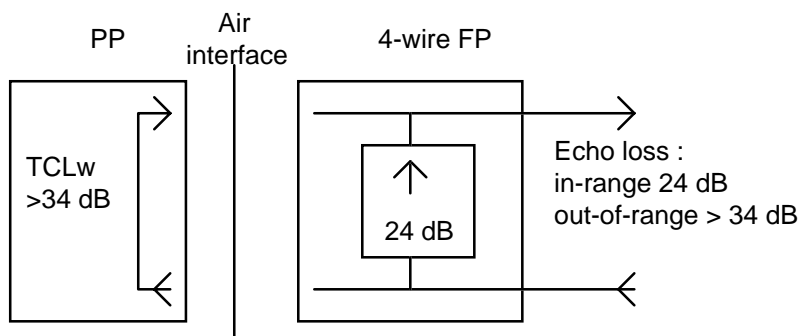

Figure 8

#### 7.14.3.2 Requirement for the ability to disable the artificial echo loss

This requirement shall be applicable to all FPs approved as separate items and FPs approved as part of a DECT System where all PPs do not have  $\text{TCLw} > 46 \text{ dB}$ .

The FP shall disable the artificial echo loss on receipt of a protocol message from the PP indicating full TCLw.

#### 7.14.3.3 Method of measurement of artificial echo loss

The FP shall have its artificial echo path activated and the speech path via the air interface de-activated. Any echo control device as specified in subclause 7.14.4 shall be disabled.

A digital signal generator, or analogue signal generator followed by an ideal codec shall be connected to the TAP-interface of the FP.

The signal generator shall be set to provide a signal level of  $-10 \text{ dBm}_0$  at the input of the TAP-interface.

The level at the output of the TAP-interface shall be evaluated using the level meter for one twelfth-octave intervals as given by the R40 series of preferred numbers in ISO 3 [27] for frequencies 300 Hz to 3 350 Hz.

The artificial echo loss shall be calculated according to ITU-T Recommendation G.122 [14].

#### **7.14.3.4 Method of measurement for ability to disable artificial echo loss**

##### **7.14.3.4.1 EUTs being approved as separate items**

- 1) The LT shall set-up a call with the EUT and send the relevant message containing the <<TERMINAL CAPABILITY>> information element as described in EN 300 175-5 [5], subclause 7.7.41, indicating full TCLw. If the EUT conforms to an ETSI defined profile, the relevant message defined by this profile shall be used.
- 2) Repeat the test described in subclause 7.14.3.3.
- 3) The artificial echo loss shall be greater than 34 dB.

##### **7.14.3.4.2 EUTs being approved as a DECT system with a PP having full TCLw**

- 1) The PP of the DECT System shall be used to set-up a call, with a full TCLw indication, with the EUT;
- 2) repeat the test described in subclause 7.14.3.3;
- 3) the artificial echo loss shall be greater than 46 dB.

#### **7.14.4 Echo control device of a FP with a 4-wire interface**

##### **7.14.4.1 Requirement for the echo control device**

An echo control device shall be implemented into the FP. The TCLw of the DECT system, defined from the FP line input to the FP line output, shall be at least 46 dB.

##### **7.14.4.2 Requirement for the ability to disable the echo control device**

This requirement shall be applicable to all FPs approved as separate items and FPs approved as part of a DECT System where all PPs do not have TCLw > 46 dB.

The FP shall disable the artificial echo loss on receipt of a protocol message from the PP indicating full TCLw.

##### **7.14.4.3 Method of measurement for the echo control device**

The FP shall have its echo control device activated and no activated artificial echo path.

A digital signal generator, or analogue signal generator followed by an ideal codec shall be connected to the TAP-interface of the FP.

The signal generator shall be set to provide a signal level of -10 dBm<sub>0</sub> at the input of the TAP-interface.

The input of the TAP-interface at the RePP shall be connected to the output of the TAP-interface at the RePP with a 34 dB loss.

The level at the output of the TAP-interface at the FP shall be evaluated using the level meter for one twelfth octave intervals as given by the R40 series of preferred numbers in ISO 3 [27] for frequencies 300 Hz to 3 350 Hz.

The TCLw shall be calculated according to ITU-T Recommendation G.122 [14], annex B.4, Trapezoidal rule.

#### 7.14.4.4 Method of measurement for the ability to disable the echo control function

##### 7.14.4.4.1 EUTs being approved as separate items

- 1) The LT shall set-up a call with the EUT and send the relevant message containing the <<TERMINAL CAPABILITY>> information element as described in EN 300 175-5 [5], subclause 7.7.41, indicating full TCLw. If the EUT conforms to an ETSI defined profile, the relevant message defined by this profile shall be used.
- 2) Repeat the test described in subclause 7.14.4.3.
- 3) The TCLw shall be less than 46 dB.

##### 7.14.4.4.2 EUTs being approved as a DECT system with a PP having full TCLw

- 1) The PP of the DECT System shall be used to set-up a call, with a full TCLw indication, with the EUT.
- 2) Repeat the test described in subclause 7.13.4.
- 3) The TCLw shall be as measured in subclause 7.13.4.

#### 7.15 Stability loss - fixed geometry

##### 7.15.1 Requirement

The attenuation from the digital input to the digital output shall be at least 6 dB at all frequencies in the range of 200 Hz to 4 000 Hz.

##### 7.15.2 Method of measurement

- a) With the digital signal generator, or the analogue signal generator, followed by an ideal codec, set to provide a signal level of -10 dBm0 at the uniform PCM point B of figure 5, the attenuation from the input B to the output A shall be measured at one-twelfth octave intervals for frequencies in the range 200 Hz to 4 000 Hz under the conditions in b).
- b) The PP shall be placed on one inside surface of three perpendicular plane smooth hard surfaces forming a corner. Each corner shall extend 0,5 m from the apex of the corner. One surface shall be marked with a diagonal line extending from the corner and a reference position marked on the line 250 mm from the corner.

The PP shall be positioned centrally along the diagonal line with the earcap nearer to the apex of the corner such that:

- 1) the mouthpiece and earcap shall face towards the surface; and
- 2) the extremity of the PP shall coincide with "the normal to the reference point".

#### 7.16 Stability loss variable geometry

##### 7.16.1 Requirement

The attenuation from the digital input to the digital output shall be at least 6 dB at all frequencies in the range of 200 Hz to 4 000 Hz.



### 7.16.2 Method of measurement

The equipment shall meet the requirement in at least one of the two following conditions:

- a) if the movement and orientation of the acoustic elements are fixed by means of a hinge or similar mechanism while the PP is active, the requirement shall be met for these fixed positions. The measurement shall be carried out in the corner described under point b) of subclause 7.15.2. In the just off-hook position the measurement shall be carried out under free field conditions;
- b) if the movement and orientation of the acoustic elements are not fixed while the PP is active, the requirement shall be met for any position and orientation that can be achieved. The measurement shall be carried out in the corner described under point b) of subclause 7.15.2.

With the digital signal generator, or the analogue signal generator followed by an ideal codec, set to provide a signal level of -10 dBm0 at the uniform PCM point D of figure 5, the attenuation from the input B to the output A shall be measured at one twelfth octave intervals for frequencies in the range 200 Hz to 4 000 Hz.

### 7.17 Sending distortion

#### 7.17.1 Requirement

The ratio of signal to total distortion (harmonic and quantizing) measured at the line interface shall not be less than 33 dB.

#### 7.17.2 Method of measurement

NOTE: The test methods defined in TBR 008 [11] are inappropriate when ADPCM coding is used. A provisional method of measurement is therefore provided. A more general method of measurement is under study.

A pure tone signal of -4,7 dBPa and nominal frequency between 1 004 Hz and 1 025 Hz shall be applied at the MRP as described in ITU-T Recommendation P.64 [24], using an artificial mouth conforming to ITU-T Recommendation P.51 [22].

A digital measuring instrument, or an ideal codec followed by an analogue level measuring set, shall be connected to point A of the ReFP as shown in figure 5 or to the TAP-reference point of a FP.

The ratio of the signal to total distortion power at the output A shall be measured with the psophometric noise weighting as described in ITU-T Recommendation G.712 [17] and CCITT Recommendation O.132 [19].

### 7.18 Receiving distortion

#### 7.18.1 Requirement

The ratio of signal to total distortion (harmonic and quantizing) measured at the ERP shall not be less than 33 dB.

#### 7.18.2 Method of measurement

NOTE: A more general method of measurement is under study.

A digital signal generator, or an analogue signal generator, followed by an ideal codec, shall be connected to point B of the ReFP, as shown in figure 5, or to the TAP-reference point of a FP, and the level shall be adjusted to produce a digitally simulated sine-wave of nominal frequency between 1 004 Hz and 1 025 Hz at a level of -10 dBm0 at the uniform PCM reference point D.

The ratio of signal to total distortion power of the signal output in the artificial ear shall be measured with the psophometric noise weighting. See figures 3 and 4 and ITU-T Recommendation G.712 [17] and CCITT Recommendation O.132 [19].

**7.19 Side tone distortion**

**7.19.1 Requirement**

The third harmonic distortion generated by the PP shall not be greater than 10 %.

**7.19.2 Method of measurement**

The PP shall be mounted at the LRGP and the earpiece shall be sealed to the knife-edge of the artificial ear. An instrument capable of measuring the third harmonic distortion of signals with fundamental frequencies in the range of 315 Hz to 1 000 Hz shall be connected to the artificial ear.

A pure-tone signal of -4,7 dBPa shall be applied at the mouth reference point at frequencies of 315 Hz, 500 Hz and 1 000 Hz. For each frequency, the third harmonic distortion shall be measured in the artificial ear.

**7.20 Out of band (sending)**

**7.20.1 Requirement**

With any sine-wave signal above 4,6 kHz and up to 8 kHz applied at the MRP at a level of -4,7 dBPa, the level of any image frequency produced at the digital interface shall be below a reference level obtained at 1 kHz (-4,7 dBPa at MRP) by at least the amount in dB specified in table 7.

**Table 7: Discrimination levels - sending**

Boundaries of signal frequencies	Limit (minimum)
4,6 kHz	30 dB
8 kHz	40 dB

The limits at intermediate frequencies lie on a straight line drawn between the given values on a log (frequency) - linear (dB) scale.

**7.20.2 Method of measurement**

- a) A digital measuring instrument, or an ideal codec followed by an analogue level measuring set, shall be connected to point A of the ReFP as shown in figure 5 or to the TAP-reference point of a FP;
- b) a pure sine wave of level -4,7 dBPa shall be applied at the MRP;
- c) for applied frequencies of 4,65 kHz, 5,0 kHz, 6,0 kHz, 6,5 kHz, 7,0 kHz, and 7,5 kHz, the level of the corresponding image frequency shall be measured.

**7.21 Out of band (receiving)**

**7.21.1 Requirement**

With a digitally-simulated sine-wave signal in the frequency range of 300 Hz to 3 400 Hz at a level of -10 dBm0 applied at the digital interface, the level of spurious out-of-band image signals in the frequency range of 4,6 kHz to 8 kHz measured selectively at the ERP shall be lower than the in-band acoustic level produced by a digital signal at 1 kHz set at the level specified in table 8.

**Table 8: Discrimination levels - receiving**

Boundaries of signal frequencies	Equivalent i/p level of 1 kHz
4,6 kHz	-35 dBm0
8 kHz	-45 dBm0

The limits at intermediate frequencies lie on a straight line drawn between the given values on a log(frequency)-linear(dB) scale.

### 7.21.2 Method of measurement

A digital signal generator, or an analogue signal generator followed by an ideal codec, shall be connected to point B of the ReFP as shown in figure 5 or to the TAP-reference point of a FP, and shall be set to provide a signal level of -10 dBm<sub>0</sub> at the uniform PCM reference point D.

For input signals at the frequencies 500 Hz, 1 000 Hz, 2 000 Hz, and 3 150 Hz, the level of the corresponding image signals at frequencies up to 8 kHz shall be measured at the ear reference point.

## 7.22 Sending noise

### 7.22.1 Requirement

The noise produced by the apparatus in the sending direction shall not exceed -64 dBm<sub>0p</sub>.

### 7.22.2 Method of measurement

The PP shall be mounted at the LRGP and the earpiece sealed to the knife-edge of the artificial ear in an acoustically quiet environment (ambient noise less than -64 dBPa(A)).

A digital measuring instrument, or an ideal codec followed by an analogue level measuring set, shall be connected to point A of the ReFP as shown in figure 5, or to the TAP-reference point of a FP.

The noise level at the PCM interface point A shall be measured using psophometric weighting as described in CCITT Recommendations G.223 [15], table 4.

## 7.23 Sending noise (narrow band)

### 7.23.1 Requirement

The narrow-band noise (due to TDMA) produced by the apparatus in the sending direction, and contained within any 10 Hz bandwidth between the frequency limits 300 Hz to 3 400 Hz, shall not exceed -73 dBm<sub>0</sub>.

### 7.23.2 Method of measurement

The PP shall be mounted at the LRGP and the earpiece sealed to the knife-edge of the artificial ear in the Low Noise Room (LNR).

An ideal codec followed by a selective measuring set or spectrum analyser with an effective bandwidth of 10 Hz shall be connected to point A of the ReFP as shown in figure 5, or to the TAP-reference point of a FP.

The rms voltage of the 10 Hz band limited signal shall be measured within the frequency range 305 Hz to 3 395 Hz.

## 7.24 Receiving noise

### 7.24.1 Requirement

If no user-controlled receiving volume control is provided, or if it is provided, at the setting where the RLR<sub>H</sub> is equal to the nominal value, the noise produced by the apparatus and measured at the ERP shall not exceed -54 dBPa(A).

### 7.24.2 Method of measurement

A digital signal generator, or an analogue signal generator followed by an ideal codec, shall be connected to point B of the ReFP as shown in figure 5, or to the TAP-reference point of a FP, and shall be set to provide a signal corresponding to decoder value number 1 at the uniform PCM reference point D.

With an ambient noise level not exceeding -64 dBPa(A), the noise level in the artificial ear shall be measured.

**7.25 Sampling frequency level (receiving)**

**7.25.1 Requirement**

The level of the 8 kHz measured selectively at the ERP shall be less than -70 dBPa.

**7.25.2 Method of measurement**

A digital signal generator, or an analogue signal generator followed by an ideal codec, shall be connected to point B of the ReFP as shown in figure 5, or to the TAP-reference point of a FP, and shall be set to provide a signal corresponding to decoder value number 1 at the uniform PCM reference point D.

With an ambient noise level not exceeding -64 dBPa(A), the level of any 8 kHz signal in the artificial ear shall be measured.

**7.26 Acoustic shock**

The essential requirements and test for acoustic shock are not within the scope of the present document. They are covered by 73/23/EEC [26] (the Low Voltage Directive).

For information see annex D.

**7.27 DECT network delay**

This test shall only apply when testing a FP and a PP as a pair.

**7.27.1 Requirement**

The sum of the delays from the MRP to the electrical line interface and from the electrical line interface to the ERP (round-trip delay) shall not exceed 28,5 ms, for a digital line interface. If an analogue line interface is provided, the delay shall not exceed 29 ms including the A/D and D/A converters at the interface to the external network.

**7.27.2 Method of measurement**

The PP shall be mounted in the LRGP. The earpiece shall be sealed to the knife-edge of the artificial ear. The delay in send and receive directions shall be measured separately from MRP to the electrical interface ( $D_s$ ) and from the electrical interface to ERP ( $D_r$ ). The acoustic input level shall be -4,7 dBPa. The level of the input signal at the electrical interface shall be adjusted to give -10 dBm0 at the TAP-reference point.

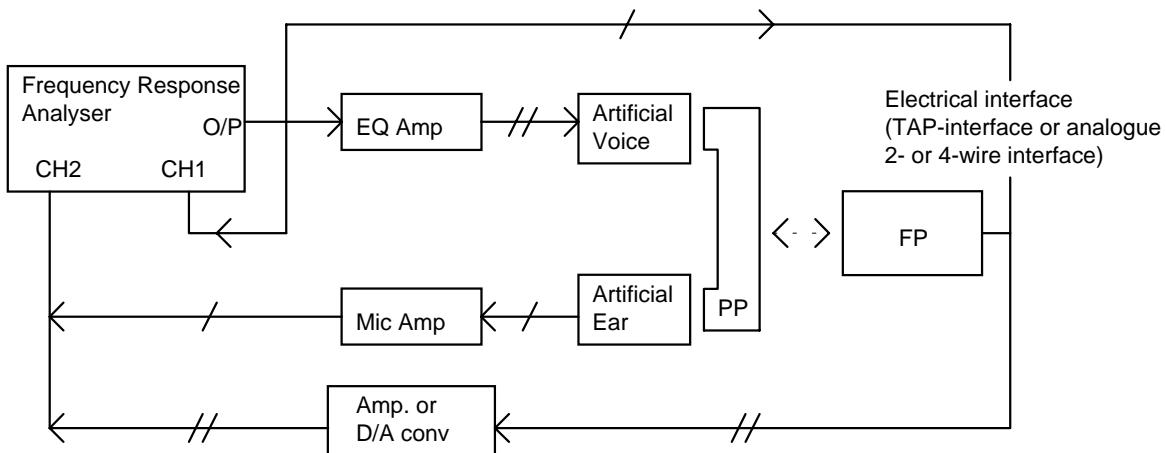

-/-- Receive direction ( $D_r$ ).

-// Send direction ( $D_s$ ).

**Figure 9: DECT network delay test configuration**

The delay shall be measured alternatively:

- a) by the cross-correlation method as described in annex C;
- b) by the method based on group delay.

For each of the nominal frequencies (f0) given in table 9 in turn, the delay at each value of f0 shall be derived from the measurements at the corresponding values of f1 and f2.

**Table 9: Frequencies for delay measurement**

<b>f0 (Hz)</b>	<b>f1 (Hz)</b>	<b>f2 (Hz)</b>
500	495	505
630	625	635
800	795	805
1 000	995	1 005
1 250	1 245	1 255
1 600	1 595	1 605
2 000	1 995	2 005
2 500	2 495	2 505

For each value of f0, the delay shall be evaluated as follows:

- 1) output the frequency f1 from the frequency response analyser;
- 2) measure the phase shift in degrees between CH1 and CH2 (P1);
- 3) output the frequency f2 from the frequency response analyser;
- 4) measure the phase shift in degrees between CH1 and CH2 (P2);
- 5) compute the delay in milliseconds using the formula:

$$D = [ -1000 \times ( P1 - P2 ) ] / [ 360 \times ( f1 - f2 ) ]$$

the measured phases P2 and P1 shall be used as original values. It is possible to have negative values at individual frequencies. Care shall be taken that this real effect is not confused with measurement effects caused by passing 360°.

The delay introduced by the artificial mouth shall be measured by mounting the artificial ear microphone at the MRP. The delay of all additional test equipment D<sub>e</sub> shall be determined using the procedures described above.

The delay of the item under test shall be deduced from the formula:

$$D = D_s + D_r - D_e$$

- 6) the network delay (PP and FP combined) shall be the mean value of the 8 measured delay values of D.

## **7.28 PP delay**

This test shall only apply when testing a separate PP.

### **7.28.1 Requirement**

The sum of the delays from the MRP to the air interface and from the air interface to the ERP (round-trip delay) shall not exceed 14,5 ms.

7.28.2 Method of measurement

A ReFP with a known 2-way delay  $D_{ReFP}$  between the air interface and the digital line interface shall be used. The PP shall be mounted at LRGP. The earpiece shall be sealed to the knife-edge of the artificial ear. The delay in send and receive directions shall be measured separately from MRP to the digital interface ( $D_s$ ) and from the digital interface to ERP ( $D_r$ ). The acoustic input level shall be 4,7 dBPa. The level of the input signal at the electrical interface shall be adjusted to give -10 dBm0 at the TAP-reference point.

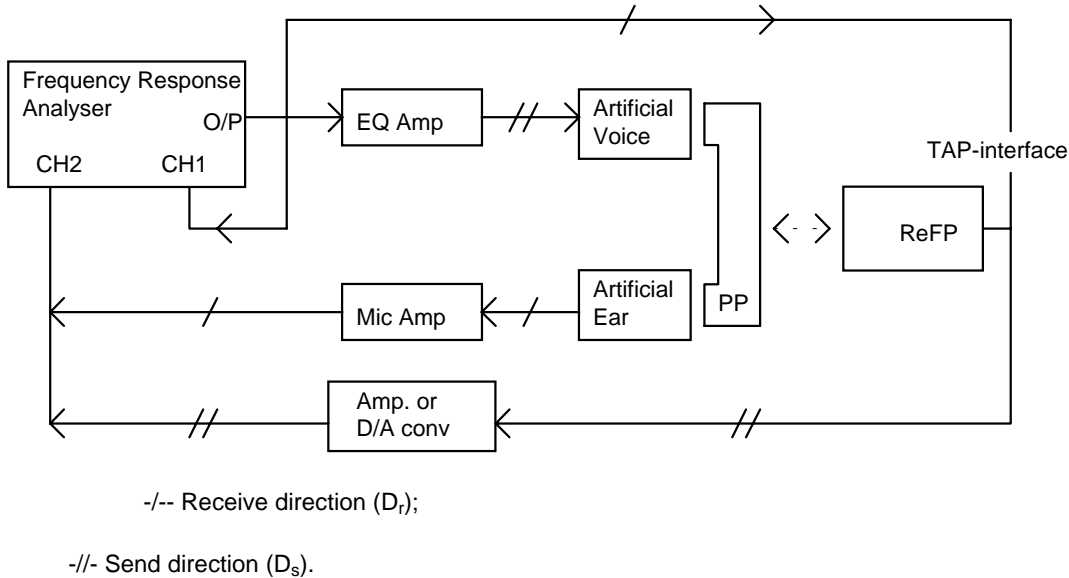

Figure 10: PP delay test configuration

The delay shall be measured alternatively:

- a) by the cross-correlation method as described in annex C;
- b) by the method based on group delay.

For each of the nominal frequencies ( $f_0$ ) given in table 9 in turn, the delay at each value of  $f_0$  shall be derived from the measurements at the corresponding values of  $f_1$  and  $f_2$ .

For each value of  $f_0$ , the delay shall be evaluated as follows:

- 1) output the frequency  $f_1$  from the frequency response analyser;
- 2) measure the phase shift in degrees between CH1 and CH2 ( $P_1$ );
- 3) output the frequency  $f_2$  from the frequency response analyser;
- 4) measure the phase shift in degrees between CH1 and CH2 ( $P_2$ );
- 5) compute the delay in milliseconds using the formula:

$$D = [ -1000 \times ( P_1 - P_2 ) ] / [ 360 \times ( f_1 - f_2 ) ]$$

the measured phases  $P_2$  and  $P_1$  shall be used as original values. It is possible to have negative values at individual frequencies. Care shall be taken that this real effect is not confused with measurement effects caused by passing  $360^\circ$ .

The delay introduced by the artificial mouth shall be measured by mounting the artificial ear microphone at the MRP. The delay of all additional test equipment  $D_e$  shall be determined using the procedures described above.

The delay of the item under test shall be deduced from the formula:

$$D = D_s + D_r - D_e - D_{ReFP}$$

- 6) the PP delay shall be the mean value of the 8 measured delay values of  $D$ .

## 7.29 FP delay

This test shall apply when testing a separate FP.

### 7.29.1 Requirement

The sum of the delays from the electrical line interface to the air interface and from the air interface to the electrical line interface (round-trip delay) shall not exceed 15 ms for a digital line interface. If an analogue line interface is provided the delay shall not exceed 15,5 ms.

### 7.29.2 Method of measurement

A RePP with a known 2-way delay  $D_{RePP}$  between the air interface and the acoustical interface shall be used. The PP shall be mounted at LRGP. The earpiece shall be sealed to the knife-edge of the artificial ear. The delay in send and receive direction shall be measured separately from MRP to the electrical interface ( $D_s$ ) and from electrical to ERP ( $D_r$ ). The acoustic input level shall be -4,7 dBPa. The level of the input signal at the electrical interface shall be adjusted to give -10 dBm0 at the TAP-reference point.

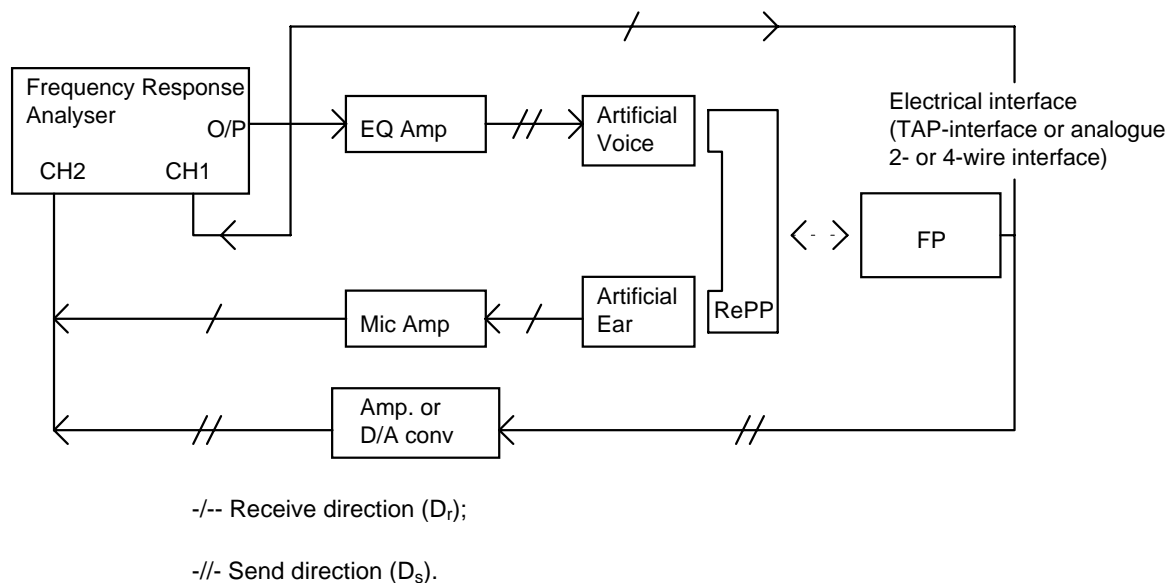

**Figure 11: FP delay test configuration**

The delay shall be measured alternatively:

- a) by the cross-correlation method as described in annex C;
- b) by the method based on group delay.

For each of the nominal frequencies ( $f_0$ ) given in the table 9 in turn, the delay at each value of  $f_0$  shall be derived from the measurements at the corresponding values of  $f_1$  and  $f_2$ .

For each value of  $f_0$ , the delay shall be evaluated as follows:

- 1) output the frequency  $f_1$  from the frequency response analyser;
- 2) measure the phase shift in degrees between CH1 and CH2 ( $P_1$ );
- 3) output the frequency  $f_2$  from the frequency response analyser;
- 4) measure the phase shift in degrees between CH1 and CH2 ( $P_2$ );
- 5) compute the delay in milliseconds using the formula:

$$D = [ -1000 \times ( P_1 - P_2 ) ] / [ 360 \times ( f_1 - f_2 ) ]$$

the measured phases  $P_2$  and  $P_1$  shall be used as original values. It is possible to have negative values at individual frequencies. Care shall be taken that this real effect is not confused with measurement effects caused by passing  $360^\circ$ .

The delay introduced by the artificial mouth shall be measured by mounting the artificial ear microphone at the MRP. The delay of all additional test equipment  $D_e$  shall be determined using the procedures described above.

The delay of the item under test shall be deduced from the formula:

$$D = D_s + D_r - D_e - D_{ReFP}$$

6) The FP delay shall be the mean value of the 8 measured delay values of D.

### 7.30 Echo control at the network side

#### 7.30.1 Requirement

The network echo shall be controlled by inserting into the receiving speech path of the FP an echo loss meeting the requirements as defined in table 10.

**Table 10: Network echo control requirements**

<b>Echo path delay (2-way)</b>	
Req. 1 - 0 ms to 4 ms	TELR $\geq$ 24 dB
Req. 2 - 0 ms to 60 ms	Extra echo loss $\geq$ 9 dB

Requirement 1 applies only to FP with an analogue 2-wire line interface. Requirement 2 applies for both 2 and 4-wire line interfaces. If the echo control device in the FP contains a soft suppresser, it is recommended not to suppress more than 12 dB.

The 24 dB TELR limit applies for a PP with nominal values for  $SLR_H$  and  $RLR_H$  ( $SLR_H = 7$  dB,  $RLR_H = 3$  dB) and it corresponds to  $LLe = 24 - 7 - 3 = 14$  dB at the TAP. This requirement shall be met when the FP is terminated with the three terminating impedances, a, b and c, defined in TBR 038 [29] subclause A.2.3. Depending on routing information, on type of service and manually by the user, it may be possible to connect and disable each of the echo control functions which perform the respective requirements 1 and 2.

#### 7.30.2 Method of measurement

It shall be possible to disable every echo control function implemented in the FP. During this test, the echo control device specified in EN 300 175-8 [8], subclause 7.4.1.2 b) shall be disabled. The applicant shall declare to the test laboratory, how this shall be done.

Additionally to the test methods as specified below an alternative test method Composite Source Signal (CSS) as described in annex B may be used.

##### 7.30.2.1 4-wire interface

A signal source shall be connected to the input and a level meter to the output of the TAP interface of the RePP (see figure 12). The source shall deliver a digital signal at a level of  $L_{in} = -20$  dBm0 derived from the ITU-T Recommendation P.50 [21] assuming a flat sending frequency response of the RePP.

The TAP interface of the FP shall be connected to a delay circuit. The signal shall be looped back to provide an echo. The attenuator shall be adjusted to give a local echo loss,  $LL_e$  of 15 dB at the RePP, when the network echo control of the FP is disabled.



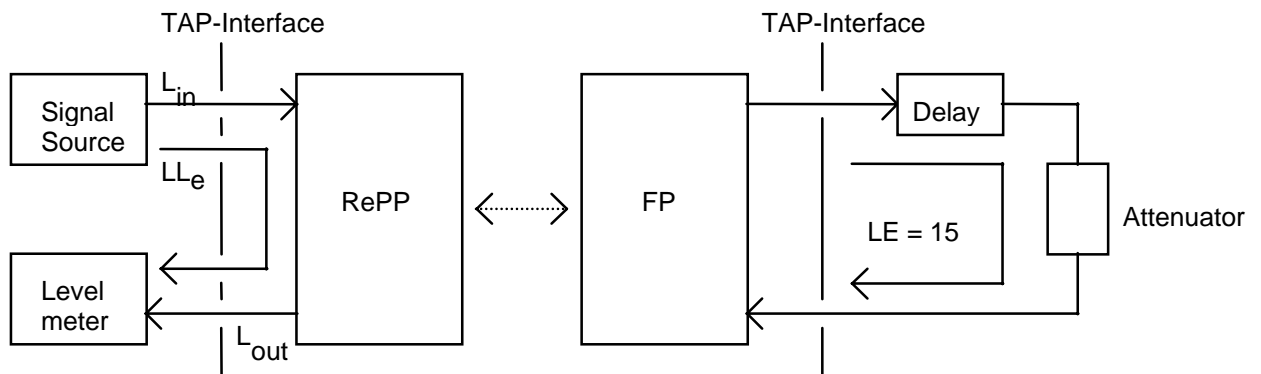

Figure 12: FP with 4-wire interface

With the network echo control enabled, the output level  $L_{out}$  shall be measured at the delays 0, 20 and 60 ms. Five measurements shall be made at each delay and the mean value shall be determined. The input signal shall be applied for more than 2 seconds before measuring. The  $LL_e$  at the TAP interface of the RePP shall be at least  $15 + 9 = 24$  dB. All echo values shall be calculated according to ITU-T Recommendation G.122 [14]. If no RePP is available for testing, a suitable accessible PCM reference point in the PP or FP, the PP shall be placed in the LRGP with its sidetone path disconnected and the artificial voice shall be applied at the MRP. The input signal levels shall be adjusted to correspond to the levels specified for the TAP-interface of the RePP corresponding with  $SLR_H = 7$  dB. Talker Echo Loudness Rating (TELR), shall be measured instead of the  $LL_e$  at the RePP. TELR shall be at least  $15 + 9 + 7 + 3 = 34$  dB when corrected to nominal values of  $SLR_H$  and  $RLR_H$  ( $SLR_H = 7$  dB,  $RLR_H = 3$  dB).

### 7.30.2.2 Analogue 2-wire interface

The DECT system consisting of the FP EUT and the RePP shall meet the SLR and RLR requirements for a 2-wire PSTN interface in subclause 7.33 with a RePP having  $SLR_H = 7$  dB and  $RLR_H = 3$  dB.

#### 7.30.2.2.1 Requirement 1

The measurement shall be made with the time dispersion inherent in the 2-4 wire hybrid circuit with the terminating impedance  $Z_R$ . The applicant shall declare that the control range of the echo control device is not less than 4 ms.

A signal source shall be connected to the input and a level meter to the output of the TAP interface of the RePP (see figure 13a). The source shall deliver a digital signal at a level of  $L_{in} = -20$  dBm0 derived from the ITU-T Recommendation P.50 [21] assuming a flat sending frequency response of the RePP.

The 2-wire interface of the FP shall be terminated by the impedance  $Z_R$  (see figure 13b). The extra echo loss of requirement 2 (see table 10) shall be set to the lowest value that can be selected according to routing information.

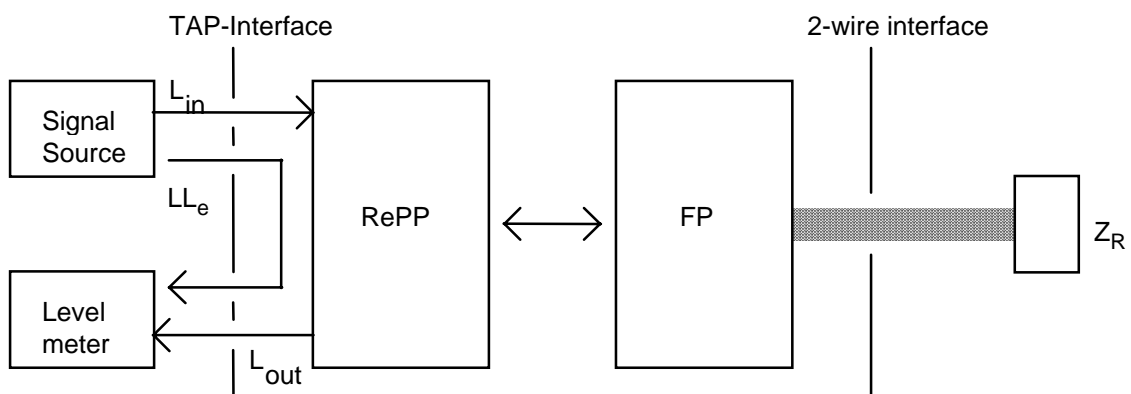

Figure 13a: FP with analogue 2-wire interface

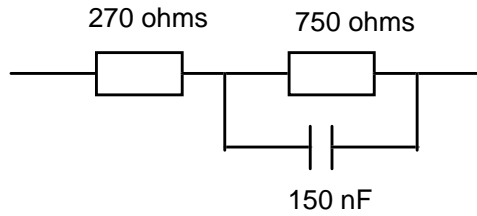

Figure 13b: Terminating impedance  $Z_R$

Five measurements shall be made of  $L_{out}$  and the mean value shall be determined. The input signal shall be applied for at least 2 seconds before measuring. The local echo loss,  $LL_e$  shall be at least 14 dB (which corresponds to  $TELR > 24$  dB assuming nominal values of  $SLR_H$  and  $RLR_H$ ). All echo values shall be calculated according to ITU-T Recommendation G. 122 [14].

The tests shall be repeated with  $Z_R$  replaced by the each of the two terminating impedances, a and c, defined in TBR 038 [29] subclause A.2.3.

If no RePP is available for testing, a suitable accessible PCM reference point in the FP may be used, if such a point is not accessible in the PP. If such a point is not accessible in the PP or FP, the PP shall be placed in the LRGP with its sidetone disconnected and white noise shall be applied at the MRP. The input signal levels shall be adjusted to correspond to the levels specified for the TAP-interface of the RePP assuming that  $SLR_H = 7$  dB.  $TELR$  shall be measured instead of the  $LL_e$  at the RePP.  $TELR$  shall be at least  $14 + 7 + 3 = 24$  dB when corrected to nominal values of  $SLR_H$  and  $RLR_H$  ( $SLR_H = 7$  dB,  $RLR_H = 3$  dB).

**7.30.2.2.2 Requirement 2**

If the option is available to reduce or disable the extra echo loss for requirement 2 (see table 10) depending upon routing information the applicant shall declare to the test laboratory how this is done.

A signal source shall be connected to the input and a level meter to the output of the TAP interface of the RePP (see figure 14). The source shall deliver a digital signal at a level of  $L_{in} = -20$  dBm0 derived from the ITU-T Recommendation P.50 [21] assuming a flat sending frequency response of the RePP.

The 2-wire interface of the FP shall be connected to a 2-wire to 4-wire hybrid circuit with a nominal input impedance  $Z_R$  (see figure 13b). The 4-wire side of the hybrid shall be connected to a circuit providing 60 ms delay. The signal shall be looped back to provide an echo. The attenuator shall be adjusted to give a local echo loss,  $LL_e$  of 15 dB at the RePP when the echo control functions of the FP are disabled.

The echo control functions for requirements 1 and 2 are reactivated. The output level  $L_{out}$  shall be measured five times and the mean value shall be determined. The input signal  $L_{in}$ , shall be applied for at least 2 seconds before is measuring.  $L_{out}$  shall be measured during a time window of 20 ms - 60 ms from the switch-off time of the input  $L_{in}$ .  $L_{in}$  shall be below -50 dBm0, 10 ms after the switch-off time.

The  $LL_e$  shall be at least 24 dB. The  $LL_e$  shall be calculated according to ITU Recommendation G.122 [14].

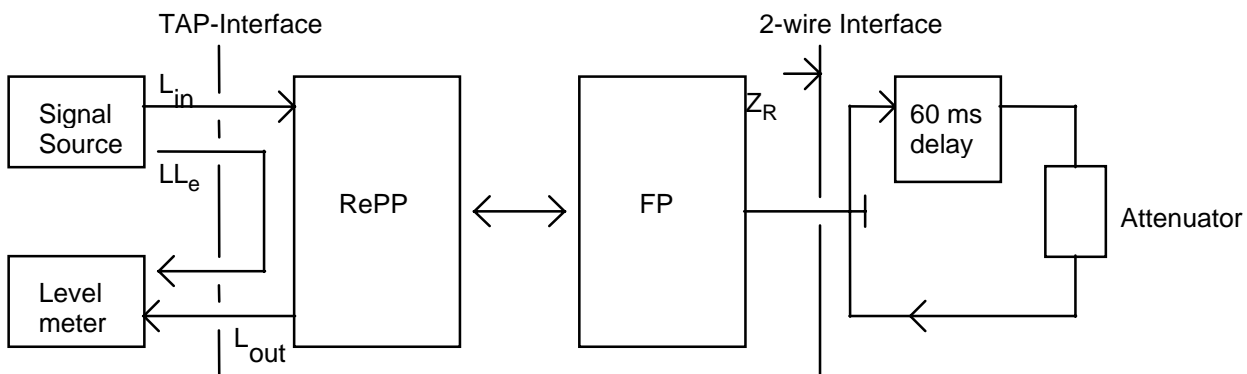

Figure 14: FP with analogue 2-wire interface

If a RePP is not available for testing, a suitable accessible PCM reference point in the FP may be used if such a point is not accessible in the PP. If such a point is not accessible in the PP or FP, the PP shall be placed in the LRGP with its sidetone disconnected and white noise shall be applied at the MRP. The input signal levels shall be adjusted to correspond to the levels specified for the TAP-interface of the RePP corresponding with  $SLR_H = 7$  dB. TELR shall be measured instead of the  $LL_e$  of the RePP. TELR shall be at least  $24 + 7 + 3 = 34$  dB when corrected to nominal values of  $SLR_H$  and  $RLR_H$  ( $SLR_H = 7$  dB,  $RLR_H = 3$  dB).

### 7.31 Variation of gain with input level-sending

#### 7.31.1 Requirement

The gain variation relative to the gain for ARL shall remain within the limits given in table 11.

Table 11: Variation of gain with input level, sending

Sending dB relative to ARL	Upper limit (dB)	Lower limit (dB)
+13	1	-11
	1	note
+4	1	-2
-30	1	-2
-30	1	$-\infty$
-40	1	
	*	
-45	6	

NOTE: The limits for intermediate levels can be found by drawing straight lines between the breaking points in the table on a linear (dB signal level) - linear (dB gain) scale.

#### 7.31.2 Method of measurement

The handset shall be mounted at LRGP and the earpiece shall be sealed to the knife-edge of the artificial ear.

A sine-wave signal with a frequency in the range 1 004 Hz to 1 025 Hz shall be applied at the MRP. The level of this signal shall be adjusted until the output of the terminal is -10 dBm0. The level of the signal at the MRP is then the ARL.

The test signal shall be applied at the following levels:

-45, -40, -35, -30, -25, -20, -15, -10, -5, 0, 5, 10, 13 dB relative to ARL.

The variation of gain relative to the gain for ARL shall be measured.

NOTE: Selective measurement may be used to avoid the effects of ambient noise.

For FPs having an echo control device (see subclause 7.14.4) and are being approved as part of a DECT system where not all PPs have  $TCLw > 46$  dB (see subclause 7.13), the measurement shall be performed with the echo control device disabled. The FP shall incorporate the means to disable the echo control device for this measurement.

### 7.32 Variation of gain with input level- receiving

#### 7.32.1 Requirement

The gain variation relative to the gain at an input level of -10 dBm0, shall be within the limits given in table 12.

Table 12: Variation of gain with input level, receiving

Receiving level at the digital interface	Upper limit (dB)	Lower limit (dB)
+3 dBm0	1	-11
	1	note
-6 dBm0	1	-2
-50 dBm0	1	-2
-50 dBm0	1	-∞

NOTE: The limits for intermediate levels can be found by drawing straight lines between the breaking points in the table on a linear (dB signal level) - linear (dB gain) scale.

### 7.32.2 Method of measurement

The handset shall be mounted at LRGP and the earpiece shall be sealed to the knife-edge of the artificial ear.

A digitally simulated sine-wave signal with a frequency in the range 1 004 Hz to 1 025 Hz shall be applied at the digital interface at the following levels:

-50, -45, -40, -35, -30, -25, -20, -15, -10, -5, 0, 3 dBm0.

The variation of gain relative to the gain at an input level of -10 dBm0 shall be measured in the artificial ear.

NOTE: Selective measurement may be used to avoid the effects of ambient noise.

### 7.33 Additional requirements for DECT systems provided with a 2-wire PSTN interface

The following additional requirements and test principles apply for complete systems or for a separate FP, when the DECT FP is provided with a 2-wire PSTN interface.

These additional requirements and test methods are to be based on TBR 038 [29] with necessary deviations justified the following:

- Any additional provision to meet these additional requirements shall be accommodated within the FP.
- Mandatory tests already performed at the 4-wire TAP interface.
- Requirements justified by the basic principles of the DECT standard including the digital radio link, the additional delay introduced and the use of small light weight portable handsets.

When testing a separate FP, the tests shall be carried out on the EUT FP in conjunction with a RePP meeting the applicable speech performance characteristics. The RePP shall have nominal values of  $SLR_H$  and  $RLR_H$  ( $SLR_H = 7$  dB,  $RLR_H = 3$  dB), or else, the acceptance criteria of the requirements below shall be adjusted according to the deviations from nominal values.

When testing a complete DECT system, the user-controlled volume control provided at the PP, shall be set as close as possible to the nominal value of  $SLR_H$  and  $RLR_H$ , unless otherwise stated.

#### 7.33.1 General

##### 7.33.1.1 Polarity independence

The requirements and associated test methods of subclause 4.1.1 of TBR 038 [29] shall apply.

##### 7.33.1.2 Feed Conditions

The requirements and associated test methods of subclause 4.1.2 of TBR 038 [29] shall apply.

### 7.33.1.3 Power supply

The requirements and associated test methods of subclause 4.1.3 of TBR 038 [29] shall apply.

### 7.33.1.4 Volume control

The requirements on volume control setting during the compliance tests are covered by the introductory text of subclause 7.33. No additional test corresponding to subclause 4.1.4 of TBR 038 [29] shall apply. Accuracy requirement of volume control setting is covered by tests of subclause 7.9, where the implicit requirement is that a setting shall be found so the loudness rating requirements for the handset are met.

No additional requirements apply.

## 7.33.2 Speech performance characteristics

The test laboratory shall perform the tests in such a way, that the results are not affected by the delay in the DECT radio interface, nor by improper activation of the DECT echo control functions. The DECT echo control functions may be disabled during the tests.

### 7.33.2.1 Sensitivity/frequency response

The test methods of subclause 4.2.1 of TBR 038 [29] shall apply.

The sensitivity curves from subclauses 7.7 and 7.8 above shall be used.

### 7.33.2.2 Sending and Receiving Loudness Ratings (SLR and RLR)

The requirements and associated test methods of subclause 4.2.2 of TBR 038 [29] shall apply, except that the RLR acceptance criteria shall be  $-8$  dB  $+7/-4$  dB for feeding resistance  $R_f$  set to  $2\ 800\ \Omega$ ,  $1\ 000\ \Omega$  and  $500\ \Omega$ .

NOTE: The basic DECT requirements (echo control, signal levels for A/D converters etc.) are optimized for digital (ISDN) transmission characteristics. Analogue transmissions over a modern network (from equipment using TBR 038 [29] values of SLR and RLR) often provide higher receive levels than a digital (ISDN) connection would. Therefore, noting that DECT PPs have a volume control with at least 6 dB gain, it should be allowed to design DECT FP equipment with a receive gain providing typical nominal RLR around  $-4$  dB. This implies for this example that the gain from the 2-wire interface to the EUT FP TAP interface should be  $3\text{dB} - (-4\ \text{dB}) = 7\ \text{dB}$ .

### 7.33.2.3 Sidetone

No additional requirements apply. Corresponding requirements of subclause 4.2.3 of TBR 038 [29] are met by the mandatory tests of subclauses 7.11 (sidetone path available in the PP) and 7.30.2.2.1 (delayed sidetone from the 4-wire/2-wire hybrid).

### 7.33.2.4 Distortion

The requirements and associated test methods of subclause 4.2.4 of TBR 038 [29] shall apply, except that the test with input e.m.f. of 0 dBV in subclause 4.2.4.2 of TBR 038 [29] shall be deleted.

NOTE: The 0 dBV level is too high and is not applicable to a digital system like DECT.

### 7.33.2.5 Linearity (variation of gain with input level)

No additional requirements apply. Corresponding requirements of subclause 4.2.5 of TBR 038 [29] are met by the mandatory more strict tests of subclauses 7.31 and 7.32.

#### 7.33.2.6 Noise

The requirements and associated test methods of subclause 4.2.6 of TBR 038 [29] shall apply, except in the test of subclause 4.2.6.1 of TBR 038 [29], where the noise acceptance criteria shall be -60 dBVp for feeding resistance  $R_f$  set to 2 800  $\Omega$ , 1 000  $\Omega$  and 500  $\Omega$ .

NOTE: The requirement has to be consistent with the requirement of subclause 7.22 for a digital system like DECT.

#### 7.33.2.7 Instability

No additional requirements apply. Corresponding requirements of subclause 4.2.7 of TBR 038 [29] are met by the mandatory tests of subclause 7.15.

#### 7.33.2.8 Echo Return Loss

The requirements and associated test methods of subclause 4.2.8 of TBR 038 [29] shall apply.

### 8 Loudspeaking and handsfree telephony

Loudspeaking and handsfree telephony may each optionally be provided. Speech performance requirements for these additional facilities are outside the scope of the present document.

If loudspeaking and/or handsfree telephony is implemented in telephony 3,1 kHz terminals, the terminals in handset mode shall fulfil the speech transmission requirements of clause 7.

## Annex A (normative): TBR Requirements Table (TBR-RT)

Table A.1 provides a summary of the essential requirement Articles 5g of the Terminal Directive, 98/13/EC [32] justifying the tests in the present document.

Table A.1

Item	Reference	TBR Requirement	Status			Support (Y/N)	Comments
			PP	FP	System		
R.1	7.6	Speech coding scheme	M	M	M		
R.2	7.7	PP sending frequency response	M		M		
R.3	7.8	PP receiving frequency response	M		M		
R.4	7.9	PP loudness rating	M		M		
R.5	7.10	User controlled volume control in the PP	M		M		
R.6	7.11	PP talker sidetone masking rating	M		M		
R.7	7.12	Listener SideTone (LST)	M		M		
R.8	7.13	Terminal Coupling Loss (TCLw) of a PP	M		M		
R.9	7.14	FP echo control functions with a 4-wire interface		M	M		
R.10	7.15	Stability loss - fixed geometry	M		M		
R.11	7.16	Stability loss variable geometry	M		M		
R.12	7.17	Sending distortion	M		M		
R.13	7.18	Receiving distortion	M		M		
R.14	7.19	Side tone distortion	M		M		
R.15	7.20	Out of band (sending)	M		M		
R.16	7.21	Out of band (receiving)	M		M		
R.17	7.22	Sending noise	M		M		
R.18	7.23	Sending noise (narrow band)	M		M		
R.19	7.24	Receiving noise	M		M		
R.20	7.25	Sampling frequency level (receiving)	M		M		
R.21	7.26	Acoustic shock					
R.22	7.27	DECT network delay			M		
R.23	7.28	PP delay	M				
R.24	7.29	FP delay		M			
R.25	7.30	Echo control at the network side		M	M		
R.26	7.31	Variation of gain with input level-sending	M		M		
R.27	7.32	Variation of gain with input level- receiving	M		M		
R.28	7.33	2-wire interface test		M	M		

Table A.2 provides a detailed listing of the test cases contained in test case R.28 of table A.1.

**Table A.2**

Item	Reference	TBR Requirement	Status			Support (Y/N)	Comments
			PP	FP	System		
R.28.1	7.33.1.1	Polarity independence		M	M		
R.28.2	7.33.1.2	Feeding Conditions		M	M		
R.28.3	7.33.1.3	Power Supply		M	M		
R.28.4	7.33.2.1	Sensitivity/frequency response		M	M		
R.28.5	7.33.2.2	Sending and Receiving loudness rating		M	M		
R.28.6	7.33.2.4	Distortion		M	M		
R.28.7	7.33.2.6	Noise		M	M		
R.28.8	7.33.2.8	Echo Return Loss		M	M		



## Annex B (informative): Description of the CSS

### B.1 General

The Composite Source Signal is composed as a time multiplex of at least three signal sources with a:

- voiced signal to simulate voice properties for a certain activation of the transfer function;
- deterministic signal for measuring the transfer function;
- pause "signal" providing amplitude modulation.

The CSS is described in detail in ITU-T Recommendation P.51 [22] and specified in annex B of I-ETS 300 245-3 [10].

For the measurement of a DECT system the PP shall be placed in the LRGP and the test signal of the CSS shall be applied at the MRP with a level of -4,7 dBPa. For the measurement of the FP the test signal of the CSS shall be applied at the TAP of the RePP or the PP with a level of -10 dBm0. Only one measurement shall be made.

### B.2 Test signal

The test signal with the characteristic as described below is applied to the input Lin at the RePP (figure 12). The measurement starts on the output Lout of the RePP (figure 12) 28 ms after the starting of the periodical white noise. The duty cycle of the measurement shall be identical with the duty cycle of the periodical white noise.

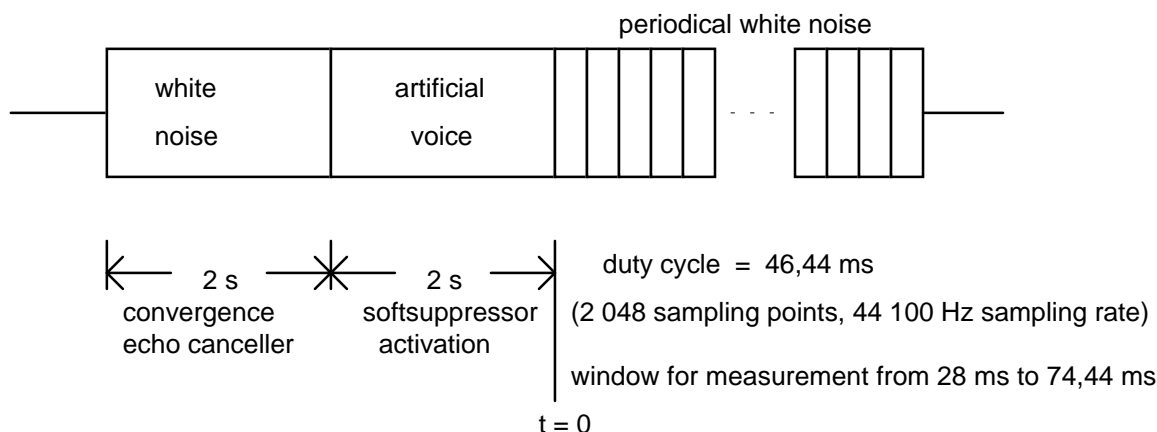

Figure B.1

artificial voice: according to ITU-T Recommendation P.50 [21] white noise band limited 100 Hz to 10 kHz.

Table B.1

Upper limit		Lower limit	
45 Hz	-36 dB	< 100 Hz	-∞ dB
90 Hz	-21 dB	100 Hz	-26,5 dB
		200 Hz	-19,5 dB
		5 000 Hz	-5,5 dB
11 200 Hz	0 dB	10 000 Hz	-6,5 dB
22 400 Hz		> 10 000 Hz	-∞ dB

### B.3 Measurement

Care should be taken for the sampling of Lin and Lout with an identical starting. The transfer function from Lin to Lout is determined by the levels Pout and Pin (at Lout and Lin respectively):

$$S_{10} = 20 \log_{10} \left( \frac{P_{out}}{P_{in}} \right) \quad (1)$$

For the determination of the transfer function an identical part of the recorded signals Lin and Lout shall be cut out (window). The time period of the window shall be identical with the time period of the white noise. For the certain receive measurement of the reflected signal the window shall start after a time period which is greater than the delay of the echo path (delay of the window).

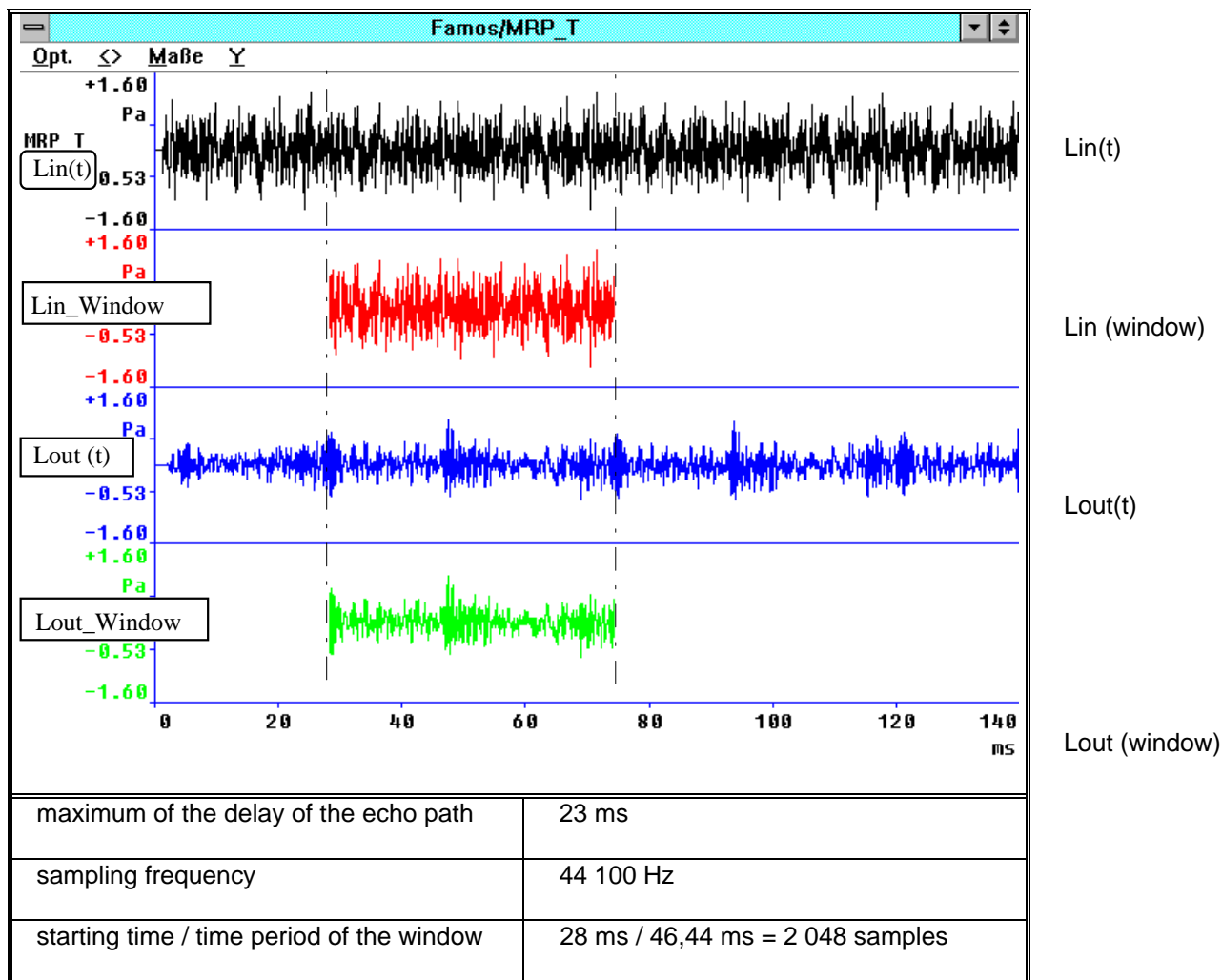

Figure B.2

## B.4 Calculation

The cut signals shall be used for the calculation of the sensitivity  $S_{io}$  by application of the Fast Fourier Transformation (FFT):

$S_{io} = \text{FFT}[\text{Loutwindow}] / \text{FFT}[\text{Linwindow}]$  for the window length of the FFT = time period of the test signal.

The time period of the window shall be applied to the FFT for the calculation to assure that all parts of the period of the test signal are used.

According to the applied bandwidth for the calculation of the Echo Loss the calculated sensitivity  $S_{io}$  shall be corrected at the upper and the lower frequency range. The values of the modulus and the phase (imaginary part) shall be reset ( $-\infty$  dB) for frequencies  $< 200$  Hz and  $> 4\,000$  Hz.

$$S_{io_{\text{corrected}}} = S_{io} \Big|_{200 \text{ Hz to } 4\,000 \text{ Hz, other values equal to } 0} \quad (2)$$

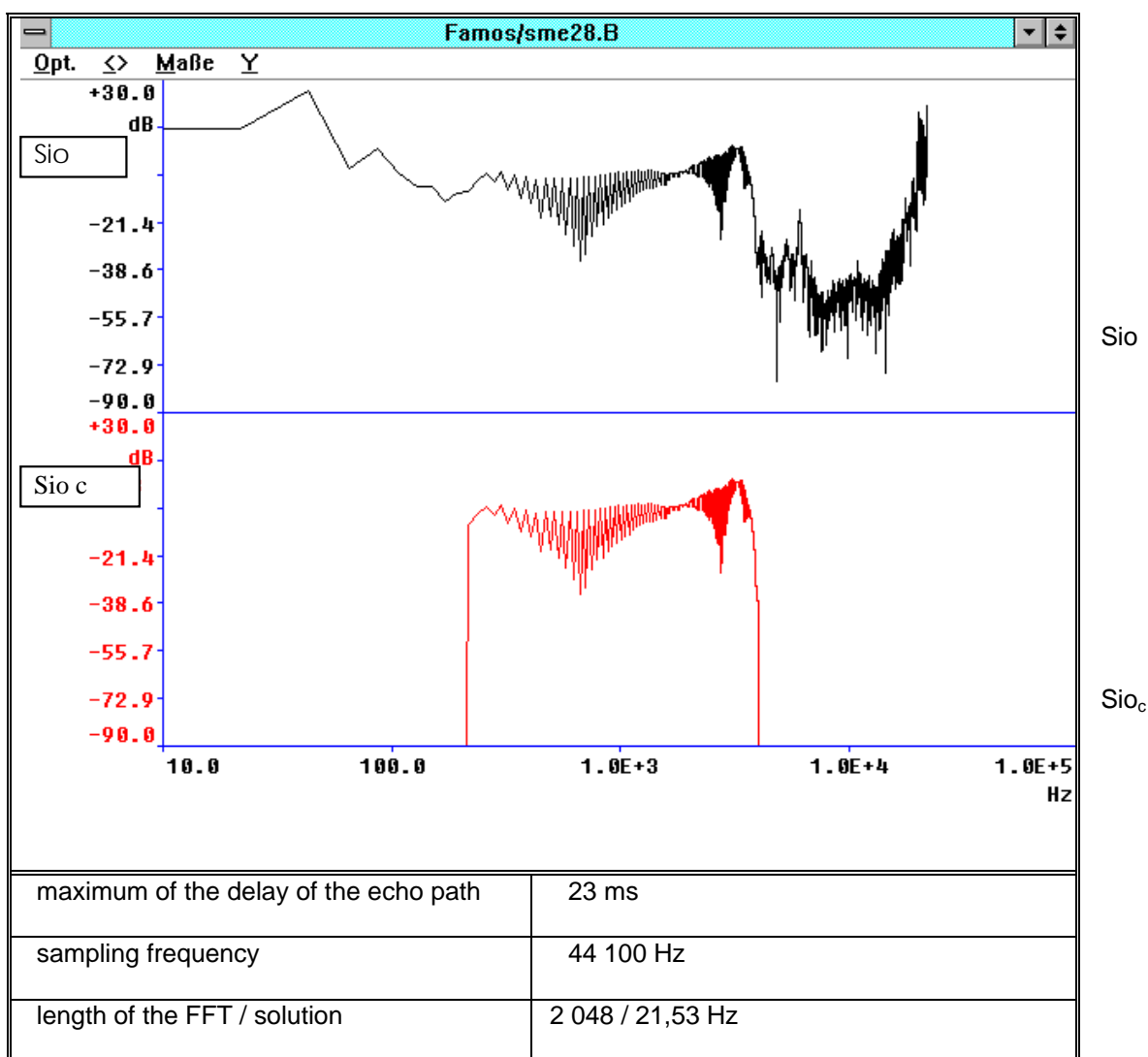

Figure B.3

The Inverse Fourier Transformation applied to the corrected transfer function  $S_{io_c}$  provides the impulse response at the time domain:

$$\text{Im}_{\text{impulse response}} = \text{iFFT}(S_{io_c}) \quad (3)$$

The impulse response demonstrates clearly the different delays for the echo and the sidetone:

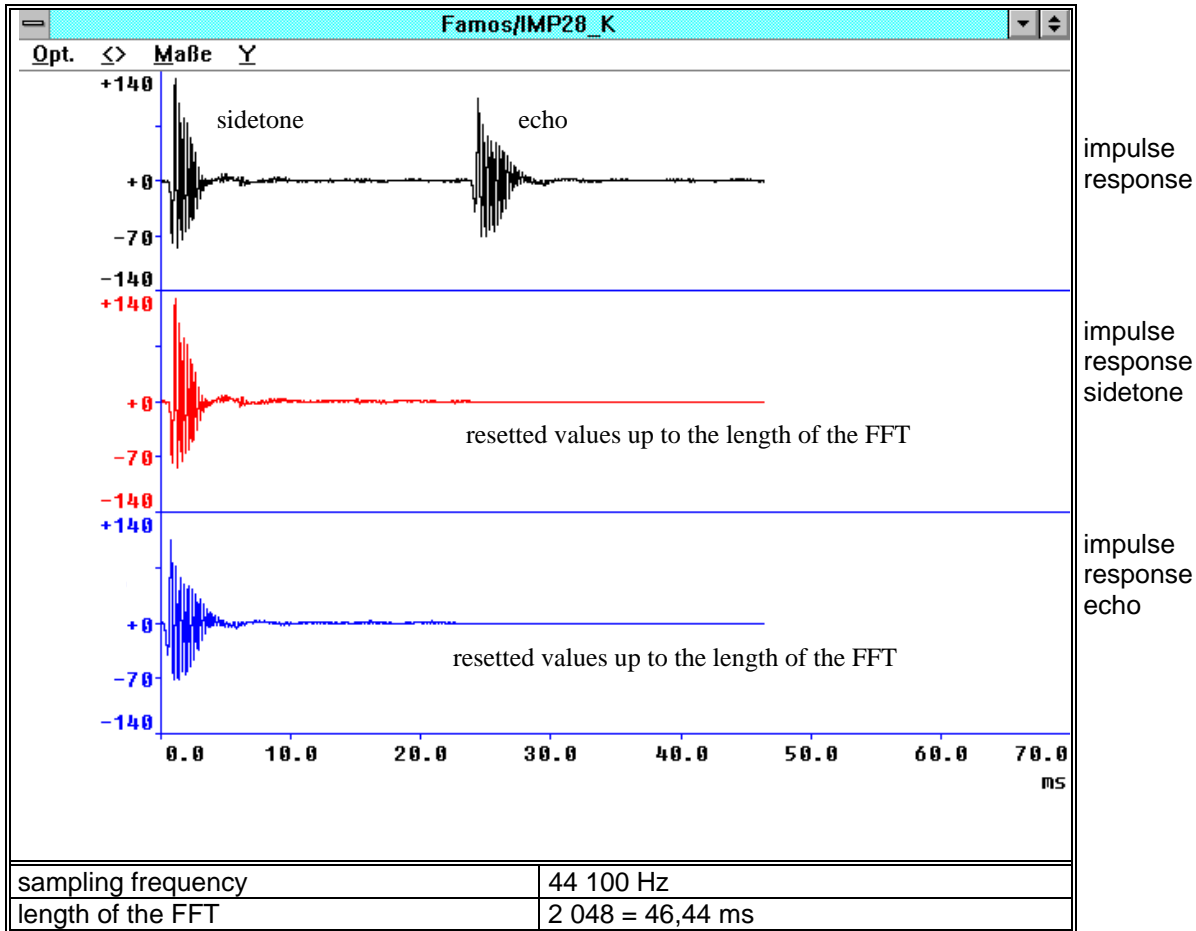

Figure B.4

The separation at the time of the echo and the sidetone at the  $L_{out}$  is possible by use of windows at the impulse response. The windows shall overlap completely the relevant time period for the specific part of the impulse response which will be considered.

The separation of this part which corresponds to the echo by use of a special window results to a new specific echo impulse response. For the further use of this new signal the echo impulse response shall be completed by adding zeroes for this time period where the sidetone was extracted. The calculation of the echo transfer function at the frequency domain is provided by the Fourier Transformation about a rectangular window at the echo impulse response.

$$S_{io_{echo}} = \text{FFT}(I_{m_{impulse response sidetone}}) \Big|_{\text{rectangular window}} \quad (4)$$

## Annex C (normative): Description of the cross-correlation method

### C.1 Test signal

The character of the test signal shall be:

- periodical white noise;
- crest factor 11 dB ± 1 dB;
- time period  $T/2 \leq 20$  ms;
- band limitation according to a third octave solution.

Table C.1

Upper limit		Lower limit	
100 Hz	-30 dB		
400 Hz	0 dB		
		500 Hz	-2 dB to --
		2 500 Hz	+5 dB to --
3 000 Hz	+8,75 dB		
20 000 Hz	-16 dB		

### C.2 Calculation

The cross-correlation function  $\Phi_{xy}(\tau)$  between the input signal  $S_x(t)$  and the output signal  $S_y(t)$  is calculated in the time domain:

$$\Phi_{xy}(\tau) = \lim_{T \rightarrow \infty} \frac{1}{T} \int_{-T/2}^{+T/2} S_x(t) S_y(t + \tau) dt \quad (5)$$

The measurement window  $T$  shall be exactly identical with the time period  $T$  of the test signal.

The delay is calculated from the envelope  $E()$  of the cross-correlation function  $\Phi_{xy}(\tau)$ . The maximum of the envelope function occurs in correspondence to the measured delay. The envelope  $E()$  is calculated by the Hilbert transformation  $H\{\Phi_{xy}(\tau)\}$  of the cross-correlation:

$$H\{\Phi_{xy}(\tau)\} = \int_{-\infty}^{+\infty} \frac{\Phi_{xy}(u)}{\Pi(\tau - u)} du \quad (6)$$

$$E() = \sqrt{[\Phi_{xy}(\tau)]^2 + \{H[\Phi_{xy}(\tau)]\}^2} \quad (7)$$

It is assumed that the measured delay is less than  $T/2$ . The delay of the test equipment shall be subtracted from the calculated result.

## **Annex D (informative): Acoustic shock requirements**

The prevention of acoustic shock is a safety requirement arising from the Low Voltage Directive (73/23/EEC) [26]. In the absence of any relevant safety standard, a supplier's self-declaration may be based on the following recommendations. The limits advised are based on sound pressure levels measured at ITU-T Recommendation P.57 [23], Type 1 artificial ear. For other types of artificial ears different sound pressure levels may be required.

### **D.1 Continuous signal**

With a digitally encoded signal representing the maximum possible signal at the digital interface, the sound pressure level in the artificial ear should not exceed 24 dBPa (RMS). Compliance shall be checked by the following test:

- a) the PP is mounted in the LRGP and the earpiece is sealed to the knife-edge of the artificial ear;
- b) a digital signal generator is connected at the digital interface. It is set to deliver the digitally encoded equivalent of a square-wave, with a peak code equal to the maximum code which can be sent over the digital line interface at frequencies in third-octave intervals as given by the R.10 series of preferred numbers in ISO 3 [27] for frequencies from 200 Hz to 4 kHz. For each frequency, the sound pressure level in the artificial ear should be measured.

### **D.2 Peak signal**

The receiving equipment should limit the peak sound pressure in the artificial ear to less than 36 dBPa. Conformance test methods are for further study. Until such methods exist, compliance should be checked by the supplier's declaration of conformance.

## **Annex E (informative): Bibliography**

The following material, though not specifically referenced in the body of the present document (or not publicly available), gives supporting information.

- EN 300 444: "Digital Enhanced Cordless Telecommunications (DECT); Generic Access Profile (GAP)".
- ETR 015: "Digital Enhanced Cordless Telecommunications (DECT); Reference document".
- ETR 043: "Digital Enhanced Cordless Telecommunications (DECT); Common interface; Services and facilities requirements specification".
- ETR 056: "Digital Enhanced Cordless Telecommunications (DECT); System description document".
- ITU-T Recommendation P.501 (1996): "Test signals for use in telephony".

## History

Document history			
December 1993	First Edition		
January 1997	Second Edition		
February 1998	Public Enquiry	PE 9824:	1998-02-13 to 1998-06-12
April 1999	Vote	V 9925:	1999-04-20 to 1999-06-18
July 1999	Third Edition		