



**T**ECHNICAL  
**B**ASIS for  
**R**EGULATION

**TBR 10**

December 1993

---

Source: ETSI TC-RES

Reference: DTBR/RES-03-10

ICS: 33.060

**Key words:** DECT, test specification, speech

**Radio Equipment and Systems (RES);  
Digital European Cordless Telecommunications (DECT)  
General terminal attachment requirements:  
Telephony applications**

**ETSI**

European Telecommunications Standards Institute

**ETSI Secretariat**

**Postal address:** F-06921 Sophia Antipolis CEDEX - FRANCE

**Office address:** 650 Route des Lucioles - Sophia Antipolis - Valbonne - FRANCE

**X.400:** c=fr, a=atlas, p=etsi, s=secretariat - **Internet:** secretariat@etsi.fr

Tel.: +33 92 94 42 00 - Fax: +33 93 65 47 16

---

**Copyright Notification:** No part may be reproduced except as authorized by written permission. The copyright and the foregoing restriction extend to reproduction in all media.

© European Telecommunications Standards Institute 1993. All rights reserved.



## Contents

Foreword .....	7
1 Scope .....	9
2 Normative references .....	10
3 Definitions and abbreviations .....	12
3.1 Definitions.....	12
3.2 Abbreviations.....	13
4 Interpretation of the measurement results .....	14
5 General test requirements.....	15
5.1 Test philosophy.....	15
5.1.1 Equipment supporting an ETSI approved profile.....	15
5.1.2 Equipment not supporting an ETSI approved profile .....	16
5.1.3 Applicant's declaration .....	16
5.2 Low noise room .....	16
5.3 Lower Tester (LT).....	16
5.3.1 Description .....	16
5.3.2 Connections between the EUT and the LT .....	17
5.3.3 Functions and abilities.....	17
5.3.4 Measurement uncertainty .....	17
5.4 Upper Tester (UT).....	17
5.4.1 Description of the UT .....	17
5.4.2 The test standby mode .....	17
5.4.3 Test messages .....	17
6 Test conditions, power sources and ambient temperatures.....	18
6.1 General.....	18
6.2 Nominal test conditions .....	18
6.3 Power source .....	18
7 Speech and telephony tests .....	19
7.1 Test configurations.....	19
7.1.1 General .....	19
7.1.2 Testing a DECT system.....	19
7.1.3 Testing a separate PP or FP.....	19
7.1.4 Reference FP, ReFP, and reference PP, RePP .....	20
7.1.5 Applicability of tests.....	21
7.2 Digital signal level.....	21
7.3 General conditions of test .....	22
7.4 Ideal codec.....	22
7.5 Electro-acoustical equipment.....	23
7.6 Speech coding scheme.....	23
7.6.1 Requirement for speech coding algorithm.....	23
7.6.2 Applicant's declaration on speech coding algorithm .....	23
7.6.3 Requirement for the digital PCM interface in the FP .....	23
7.6.4 Applicant's declaration on the digital PCM interface in the FP.....	23
7.7 PP sending frequency response .....	24
7.7.1 Requirement .....	24
7.7.2 Method of measurement .....	24
7.8 PP receiving frequency response.....	24
7.8.1 Requirement .....	25

	7.8.2	Method of measurement .....	25
7.9		PP loudness rating .....	25
	7.9.1	Requirement .....	25
	7.9.2	Method of measurement .....	25
		7.9.2.1 SLR <sub>H</sub> .....	25
		7.9.2.2 RLR <sub>H</sub> .....	25
7.10		User Controlled Volume control in the PP .....	26
	7.10.1	Requirement .....	26
	7.10.2	Method of measurement .....	26
		7.10.2.1 SLR <sub>H</sub> .....	26
		7.10.2.2 RLR <sub>H</sub> .....	26
7.11		PP talker sidetone masking rating.....	26
	7.11.1	Requirement .....	26
	7.11.2	Method of measurement .....	26
7.12		Listener SideTone .....	27
	7.12.1	LSTR requirement .....	27
	7.12.2	Protocol requirement for EUTs with declared noise rejection capability .....	27
	7.12.3	Method of measurement for LSTR.....	27
	7.12.4	Method of measurement for the Protocol Requirement for EUTs with declared noise rejection capability applying to be approved separately .....	27
	7.12.5	Applicant's declaration for the protocol requirement for EUTs applying to be approved as a DECT system.....	28
7.13		Terminal Coupling Loss of a PP.....	28
	7.13.1	TCLw requirement.....	28
	7.13.2	Protocol requirement .....	28
	7.13.3	Method of measurement for TCLw for a PP being approved separately.....	28
	7.13.4	Method of measurement for TCLw for a PP being approved as part of a DECT system.....	29
	7.13.5	Method of measurement for the protocol requirement for EUTs applying to be approved separately .....	29
	7.13.6	Applicant's declaration for the protocol requirement for EUTs applying to be approved as a DECT system.....	29
7.14		FP echo control functions with a 4-wire interface .....	29
	7.14.1	Static requirements.....	29
	7.14.2	Dynamic requirements .....	29
		7.14.2.1 Minimum TCLw.....	29
		7.14.2.2 Full TCLw.....	30
	7.14.3	Artificial echo loss of a FP with a 4-wire interface .....	30
		7.14.3.1 Requirement for artificial echo loss.....	30
		7.14.3.2 Requirement for the ability to disable the artificial echo loss .....	30
		7.14.3.3 Method of measurement of artificial echo loss.....	30
		7.14.3.4 Method of measurement for ability to disable artificial echo loss .....	30
		7.14.3.4.1 EUTs being approved as separate items .....	30
		7.14.3.4.2 EUTs being approved as a DECT system with a PP having full TCLw.....	31
	7.14.4	Echo control device of a FP with a 4-wire interface .....	31
		7.14.4.1 Requirement for the echo control device.....	31
		7.14.4.2 Requirement for the ability to disable the echo control device .....	31
		7.14.4.3 Method of measurement for the echo control device.....	31
		7.14.4.4 Method of measurement for the ability to disable the echo control function .....	31
		7.14.4.4.1 EUTs being approved as separate items .....	31
		7.14.4.4.2 EUTs being approved as a DECT system with a PP having full TCLw.....	32
7.15		Stability loss - fixed geometry.....	32

	7.15.1	Requirement .....	32
	7.15.2	Method of measurement .....	32
7.16		Stability loss variable geometry .....	32
	7.16.1	Requirement .....	32
	7.16.2	Method of measurement .....	32
7.17		Sending distortion.....	33
	7.17.1	Requirement .....	33
	7.17.2	Method of measurement .....	33
7.18		Receiving distortion .....	33
	7.18.1	Requirement .....	33
	7.18.2	Method of measurement .....	33
7.19		Side tone distortion .....	33
	7.19.1	Requirement .....	33
	7.19.2	Method of measurement .....	33
7.20		Out of band (sending).....	34
	7.20.1	Requirement .....	34
	7.20.2	Method of measurement .....	34
7.21		Out of band (receiving) .....	34
	7.21.1	Requirement .....	34
	7.21.2	Method of measurement .....	34
7.22		Sending noise .....	35
	7.22.1	Requirement .....	35
	7.22.2	Method of measurement .....	35
7.23		Sending noise (narrow band).....	35
	7.23.1	Requirement .....	35
	7.23.2	Method of measurement .....	35
7.24		Receiving noise .....	35
	7.24.1	Requirement .....	35
	7.24.2	Method of measurement .....	35
7.25		Sampling frequency level (receiving) .....	35
	7.25.1	Requirement .....	35
	7.25.2	Method of measurement .....	36
7.26		Acoustic shock.....	36
7.27		DECT network delay .....	36
	7.27.1	Requirement .....	36
	7.27.2	Method of measurement .....	36
7.28		PP delay .....	37
	7.28.1	Requirement .....	37
	7.28.2	Method of measurement .....	37
7.29		FP delay.....	38
	7.29.1	Requirement .....	38
	7.29.2	Method of measurement .....	39
7.30		Echo control at the network side .....	40
	7.30.1	Requirement .....	40
	7.30.2	Method of measurement .....	40
		7.30.2.1 4-wire interface .....	40
		7.30.2.2 Analogue 2-wire interface.....	41
		7.30.2.2.1 Requirement 1: .....	41
		7.30.2.2.2 Requirement 2: .....	42
7.31		Variation of gain with input level- sending .....	43
	7.31.1	Requirement .....	43
	7.31.2	Method of measurement .....	43
7.32		Variation of gain with input level- receiving.....	44
	7.32.1	Requirement .....	44
	7.32.2	Method of measurement .....	44
8		Loudspeaking and handsfree telephony.....	44

Annex A (informative): Essential requirement justification ..... 45

History ..... 46

## **Foreword**

This Technical Basis for Regulation (TBR) has been produced by the Radio Equipment and Systems (RES) Technical Committee of the European Telecommunications Standards Institute (ETSI) and was adopted having passed through the ETSI standards approval procedure.

This TBR covers the general attachment requirements for terminal equipment for the Digital European Cordless Telecommunications (DECT) common interface.

This TBR contains the procedures and requirements for the type examination of Digital European Cordless Telecommunications (DECT) equipment supporting a 3,1 kHz telephony teleservice.

The requirements of TBR 6 [22] apply in addition to this TBR.

This TBR is based on the DECT Common Interface ETS 300 175 [1] - [8] and [32], and I-ETS 300 176 [31].

Blank page



## 1 Scope

This Technical Basis for Regulation (TBR) specifies the technical characteristics particular to telephony applications provided by terminal equipment which is capable of connection to a public telecommunications network and which uses Digital European Cordless Telecommunications (DECT). The cordless transmissions for such terminal equipment operate within the frequency band 1 880 - 1 900 MHz.

The objective of this TBR is to ensure interworking of terminal equipment via the public network.

The requirements in this TBR apply in addition to the attachment requirements for the appropriate public network (see NOTE) and the TBR for DECT general attachment requirements.

NOTE: TBR for basic ISDN, TBR for primary rate ISDN, or national regulations (implementing ETS 300 001) for Public Switched Telephone Network (PSTN). Interconnection of a DECT terminal to a GSM network is still under study; in due course, the scope statement may need amending to reflect this point.

This TBR is applicable to simple telephony terminals as well as to the telephony function of multi-function or multi-service terminals.

This TBR includes the speech quality and transmission requirements for a 3,1 kHz telephony teleservice.

For each requirement in this TBR, a test is given, including measurement methods. The terminal equipment may be stimulated to perform the tests by additional equipment if necessary.

This TBR is not applicable to terminal equipment specially designed for the disabled (e.g. with amplification of received speech as an aid for the hard-of-hearing).

DECT comprises two equipment elements, referred to as a Fixed Part (FP) and a Portable Part (PP). This TBR is structured to allow type approval of either a) the FP and PP together, or b) the FP and PP as separate items. Where the DECT FP is connected to a PSTN, and there are any national peculiarities in the requirements for voice telephony, these shall be accommodated within the FP.

## 2 Normative references

This TBR incorporates by dated or undated reference, provisions from other publications. These normative references are cited at the appropriate places in the text and the publications are listed hereafter. For dated references, subsequent amendments to or revisions of any of these publications apply to this TBR only when incorporated in it by amendment or revision. For undated references the latest edition of the publication referred to applies.

- [1] ETS 300 175-1 (1992): "Radio Equipment and Systems (RES); Digital European Cordless Telecommunications (DECT) Common Interface Part 1: Overview".
- [2] ETS 300 175-2 (1992): "Radio Equipment and Systems (RES); Digital European Cordless Telecommunications (DECT) Common Interface Part 2: Physical layer".
- [3] ETS 300 175-3 (1992): "Radio Equipment and Systems (RES); Digital European Cordless Telecommunications (DECT) Common Interface Part 3: Medium access control layer".
- [4] ETS 300 175-4 (1992): "Digital European Cordless Telecommunications Common Interface Part 4: Data Link Control layer".
- [5] ETS 300 175-5 (1992): "Digital European Cordless Telecommunications Common Interface Part 5: Network layer".
- [6] ETS 300 175-6 (1992): "Digital European Cordless Telecommunications Common Interface Part 6: Identities and addressing".
- [7] ETS 300 175-7 (1992): "Radio Equipment and Systems (RES); Digital European Cordless Telecommunications (DECT) Common Interface Part 7: Security features".
- [8] ETS 300 175-8 (1992): "Radio Equipment and Systems (RES); Digital European Cordless Telecommunications (DECT) Common Interface Part 8: Speech coding and transmission".
- [9] ETS 300 085 (1991): "Integrated Services Digital Network (ISDN); 3,1 kHz telephony teleservice. Attachment requirements for handset terminals" (Candidate NET 33). CTR 8 will replace this ETS when available.
- [10] CCITT Revised Recommendation G.726 (IUT April 1991): "40, 32, 24, 16 kbit/s Adaptive Differential Pulse Code Modulation (ADPCM)".
- [11] CCITT Recommendation G.122 (1988): "Influence of national systems on stability, talker echo, and listener echo in international connections".
- [12] CCITT Recommendation O.132 (1988): "Quantization distortion measurement equipment using a sinusoidal input signal".
- [13] CCITT Recommendation G.223 (1988): "Assumptions for the calculation of noise on hypothetical reference circuits for telephony".
- [14] CCITT Recommendation G.714 (1988): "Separate performance characteristics for the encoding and decoding sides of PCM channels applicable to 4-wire voice frequency interfaces".
- [15] CCITT Revised Recommendation P.51 (1993): "Artificial mouth".
- [16] CCITT Revised Recommendation P.64 (1993): "Determination of sensitivity/frequency characteristics of local telephone systems to permit calculation of their loudness ratings".

- [17] CCITT Revised Recommendation P.79 (1993): "Calculation of loudness ratings".
- [18] CCITT Recommendation G.711 (1988): "Pulse Code Modulation (PCM) of voice frequencies".
- [19] CCITT Revised Recommendation P.57 (1993): "Artificial ears".
- [20] ISO 3 (1973): "Preferred numbers - series of preferred numbers".
- [21] CCITT Revised Recommendation P.50 (1993): "Artificial Voices".
- [22] TBR 6: "Radio Equipment and Systems (RES); Digital European Cordless Telecommunications (DECT) General terminal attachment requirements".
- [23] CCITT Revised Recommendation P.80 (1993): "Methods for subjective determination of transmission quality".
- [24] IEC 651: "Sound level meters".
- [25] ETS 300 111: "ISDN telephony 3,1 kHz teleservice; service description".
- [26] CCITT Recommendation G.101 (1988): "The Transmission Plan".
- [27] CCITT Recommendation O.133 (1988): "Specification for equipment to measure the performance of PCM encoders and decoders".
- [28] 91/263/EEC: "Council Directive of 29 April 1991 on the approximation of the laws of the Member States concerning telecommunications terminal equipment, including the mutual recognition of their conformity". (Terminal Directive)
- [29] ETS 300 001(1992): "Attachments to Public Switched Telephone Network (PSTN); General technical requirements for equipment connected to an analogue subscriber interface in the PSTN (NET 4)".
- [30] 73/23/EEC: Council Directive of 19 February 1973 on the harmonization of the laws of the Member States relating to electrical equipment designed for use within certain voltage limits. (Low Voltage Directive)
- [31] I-ETS 300 176 (1992): "Radio Equipment and Systems (RES); Digital European Cordless Telecommunications (DECT) Approval test specification".
- [32] ETS 300 175-9 (1992): "Radio Equipment and Systems (RES); Digital European Cordless Telecommunications (DECT) Common Interface Part 9: Public access profile".
- [33] ISO DIS 9614: "Acoustic determination of sound power levels of noise sources using sound intensity, Part 1 Measurement at discrete points.

### 3 Definitions and abbreviations

#### 3.1 Definitions

For the purposes of this TBR, the following definitions apply:

**Acoustic Reference Level (ARL):** the acoustic level that corresponds to a power level of - 10 dBm0 at the digital interface.

**Conducted measurements:** measurements which are made using a direct connection to the Equipment Under Test (EUT).

**Duplex bearer:** the use of two simplex bearers operating in opposite directions on two physical channels. These pairs of channels always use the same RF carrier and always use evenly spaced slots (i.e. separated by 0,5 TDMA frame).

**Equipment Under Test (EUT):** the equipment submitted to the test laboratory for type examination.

**Fixed geometry PP:** a PP in which the electro-acoustic transducers and their associated acoustic components are held in fixed relative positions and/or orientations during all on-line conditions of the PP.

**Fixed Part (DECT Fixed Part) (FP):** a physical grouping that contains all of the elements in the DECT network between the local network and the DECT air interface.

NOTE 1: A DECT fixed part contains the logical elements of at least one fixed radio termination, plus additional implementation specific elements.

**Fixed radio Termination (FT):** a logical group of functions that contains all of the DECT processes and procedures on the fixed side of the DECT air interface.

NOTE 2: A fixed radio termination only includes elements that are defined in ETS 300 175 [1] - [8]. This includes radio transmission elements (layer 1) together with a selection of layer 2 and layer 3 elements.

**Full slot (slot):** one 24th of a TDMA frame which is used to support one physical channel.

**Handset echo:** the echo, perceptible by the far-end user, resulting from the coupling between the receive and send directions of the handset, mostly due to acoustic coupling between transducers. It is particularly cumbersome in communications including a satellite and an echo canceller, as the DECT handset echo may be out of range of the echo canceller.

**Inter-operability:** the capability of fixed parts and portable parts, that enable a portable part to obtain access to teleservices in more than one location area and/or from more than one operator (more than one service provider).

**Local Echo (LE):** the sum of the reflections measured at the digital interface of the RePP. It is calculated according to CCITT Recommendations G.122 [11], Annex B4, Trapezoidal rule.

**Lower Tester (LT):** a logical grouping that contains the test equipment, a functionally equivalent DECT PT, a functionally equivalent DECT FT and a test controller.

**Network echo:** the echo, perceptible by the DECT user, resulting from reflections in the network. It is mostly due to hybrid impairments at both ends of the communication. The protection consists of an additional echo loss located in the receive path of the DECT system.

**Public Access Profile (PAP):** a defined part of the ETS 300 175-9 [32] that ensures inter-operability between fixed parts and portable parts for public access services.

**Portable HandSet (PHS):** a single physical grouping that contains all of the portable elements that are needed to provide a teleservice to the user.

NOTE 3: Portable handset is a subset of all possible portable parts. This subset includes all physical groupings that combine one portable radio termination plus at least one portable application in a single physical box.

**Portable Part (PP):** a physical grouping that contains all elements between the user and the DECT air interface. Portable Part (PP) is a generic term that may describe one or several physical pieces.

NOTE 4: A portable part is logically divided into one portable termination plus one or more portable applications.

**Portable radio Termination (PT):** a logical group of functions that contains all of the DECT processes and procedures on the portable side of the DECT air interface.

NOTE 5: A PT only includes elements that are defined in ETS 300 175 [1] - [8]. This includes radio transmission elements together with a selection of layer 2 and layer 3 elements.

**Public:** an attribute indicating that the application of the so qualified term is used to provide access to a public network for the general public.

NOTE 6: The term does not imply any legal or regulatory aspect, nor does it imply any aspects of ownership.

**Telephony 3,1 kHz teleservice:** a definition for telephony 3,1 kHz teleservice is to be found in ETS 300 111 [25].

NOTE 7: Work is currently being undertaken by ETSI to analyse the mouth-to-ear characteristics of voice communication. The results of this work could have consequences for the essential requirements of this TBR.

**Test laboratory:** a body which performs testing in accordance with the terminal directive. This laboratory is accredited to perform 3rd party testing.

**Upper Tester (UT):** a logical grouping that controls the EUT when under test.

NOTE 8: Commands are sent from the LT to the UT to place the EUT in the appropriate test mode.

**Variable geometry PP:** a PP that allows the position and/or orientation of its electro-acoustic transducers and their associated acoustic components to be changed during all on-line conditions of the PP.

### 3.2 Abbreviations

For the purposes of this TBR, the following abbreviations apply:

ARL	Acoustic Reference Level
BER	Bit Error Ratio
CLRR	Circuit Loudness Rating, Receive
CLRS	Circuit Loudness Rating, Send
dBm	dB relative to 1 milliwatt
dBm0	The absolute power level in deciBels referred to a point of zero relative level
dBr	The relative power level in deciBels

EUT	Equipment Under Test
FP	Fixed Part
FT	Fixed radio Termination
LmeST	Sidetone Path Loss
LE	Local echo
LRGP	Loudness Rating Guard-ring Position
LSTR	Listener Sidetone Rating
LT	Lower Tester
MRP	Mouth Reference Point
PP	Portable Part
PT	Portable radio Termination
ReFP	Reference Fixed Part (for speech testing)
RePP	Reference Portable Part (for speech testing)
RLR <sub>H</sub>	Receive Loudness Rating of the Handset
SLR <sub>H</sub>	Send Loudness Rating of the Handset
SL	Linear input Signal, see CCITT Recommendation G.726 [10]
SR	Reconstructed Signal, see CCITT Recommendation G.726 [10]
STMR	Sidetone Masking Rating
TCLw	Weighted Terminal Coupling Loss
TELR	Talker Echo Loudness Rating
UT	Upper Tester

#### **4 Interpretation of the measurement results**

The interpretation of the results recorded in a test report for the measurements described in this TBR shall be as follows:

- a) the measured value related to the corresponding limit shall be used to decide whether an equipment meets the minimum requirements of the standard;
- b) the actual measurement uncertainty of the test laboratory carrying out the measurement, for each particular measurement, shall be included in the test report;
- c) the values of the actual measurement uncertainty shall be, for each measurement, equal to or lower than the values in subclause 1 (table of measurement uncertainty).

## 5 General test requirements

Where the DECT FP is connected to a PSTN, and there are any national peculiarities in the requirements for voice telephony, these shall be accommodated within the FP, and the national authorities need to recognise that deviations of parameters which are justified by the basic principles of the DECT standard shall be approved (see ETS 300 001 [29]).

Those functions and procedures which are optional, as indicated directly or indirectly by "if provided", shall be subject to a conformance test if they are implemented. Whether an optional function/procedure has been implemented shall be indicated by the Apparatus Suppliers declaration.

### 5.1 Test philosophy

#### 5.1.1 Equipment supporting an ETSI approved profile

Equipment falling into this category is defined in ETS 300 175-1 [1].

In this case, a test equipment capable of emulating a PT or FT that conforms to ETS 300 175 [1] - [8] and [32] operating an ETSI approved profile (e.g. Public Access Profile, (PAP)) corresponding to that supported by the EUT is required. Consequently, each test set-up consists of the test equipment being connected to the EUT, either by a radio link or via an antenna connector, and a call being established. The following figures show the possible test configurations.

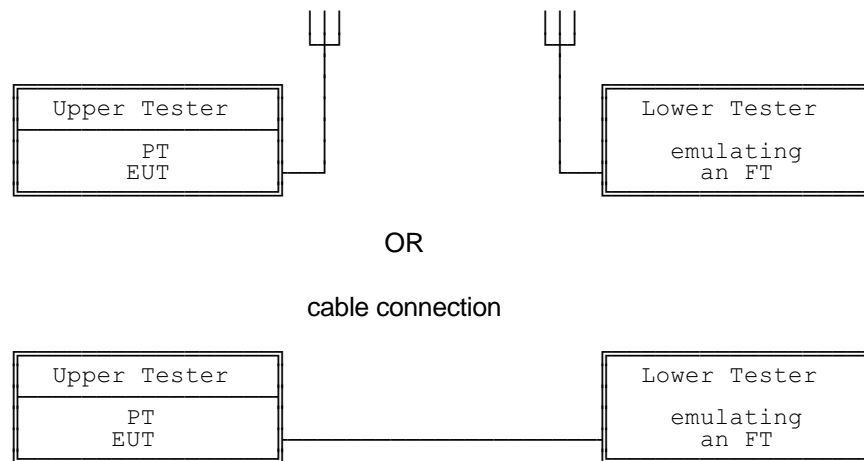

**Figure 1: The EUT is a PT**

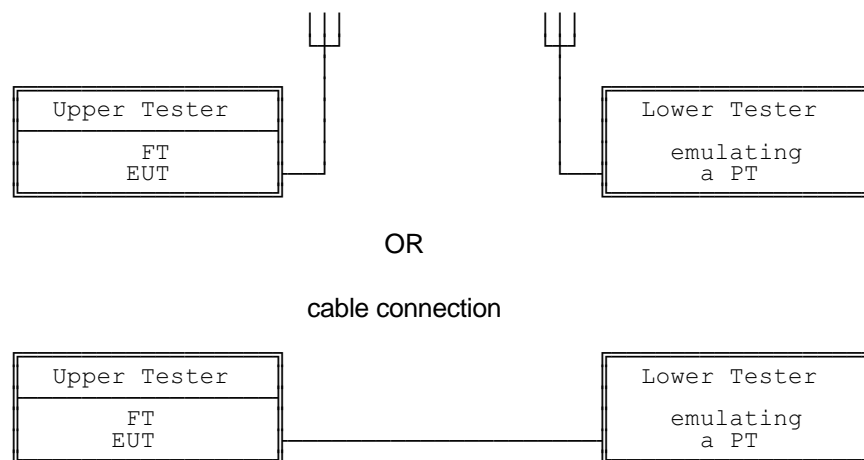

**Figure 2: The EUT is a FT**

Figures 1 and 2 also show that, if available, the EUT can sometimes be connected to the LT by an antenna connector. This is normally preferred in order to minimise the measurement uncertainties.

The Lower Tester (LT) will consist of the general test equipment with the functionality as described in subclause 1. Also it will include an RF interface which can emulate the DECT Common Interface.

The UT is contained within the EUT and operates in response to test commands which are sent by the LT over the air interface. This enables the LT to place the EUT in a variety of test modes. These are described in subclause 1.

### 5.1.2 Equipment not supporting an ETSI approved profile

Equipment falling into this category is defined in ETS 300 175-1 [1].

If an LT is available that can establish a speech connection with the EUT and the EUT supports, where required, the <<TERMINAL CAPABILITY>> information element as described in ETS 300 175-5 [5] subclause 7.7.41, then approval of an FP and a PP as a separate item is allowed, and the test philosophy described in subclause 5.1.1 shall be applicable.

If an LT is not available that can establish a speech connection with the EUT or the EUT does not support, where required, the <<TERMINAL CAPABILITY>> information element as described in ETS 300 175-5 [5] subclause 7.7.41, then the FP and PP shall be approved as a pair. The applicant shall describe to the test laboratory how a call is established, maintained and released.

However, when a PT or FT is to be tested as a separate item, the applicant shall provide the test authority with a means for establishing, maintaining and releasing a speech connection in order to test the EUT.

### 5.1.3 Applicant's declaration

Where parameters, capabilities, etc. are subject to applicant's declaration and not a specific test, it will be the applicant's responsibility to:

- a) supply a Declaration of Implementation, in which the Applicant explicitly affirms the implementation in the equipment of certain parameters and capabilities;
- b) be prepared to submit upon request supporting design information, including circuit designs and software source code, demonstrating the implementation of said capabilities;
- c) be prepared to supply upon request such test results as are practicable, including the test methods, which support the declaration.

## 5.2 Low noise room

Low noise refers to audio sound and not RF radiation.

The test space shall be practically free-field (anechoic) down to a lowest frequency of 275 Hz, and be such that the handset lies totally within the free field volume. This shall be met if deviations from the ideal free field conditions are less than  $\pm 1$  dB. The ambient noise level shall be less than -64 dBPa(A). Measurements made in the low noise room shall satisfy the measurement uncertainty requirements described in subclause 2.

## 5.3 Lower Tester (LT)

### 5.3.1 Description

The LT is a logical grouping that contains a ReFP, RePP, the measurement equipment and the controller of the DECT testing system. The LT has the job of sending testing commands, performing calculations (e.g. signal processing) and interacting with the EUT for the various tests. The LT shall implement the mandatory parts of the DECT specification (see TBR 6 [22]) and any ETSI approved profiles (e.g. PAP). The LT may implement the Test Support Profile described in TBR 6 [22] Annex D in order to support the tests messages and procedures in a fully standardised manner.



When testing EUTs that do not support an ETSI approved profile, the LT is not required to have implemented an ETSI approved profile. See subclause 1.

### 5.3.2 Connections between the EUT and the LT

This is specified in each test case.

### 5.3.3 Functions and abilities

The LT shall include all the functions necessary to perform the tests and measurements as described in this TBR according to the measurement uncertainties described in subclause 3.

### 5.3.4 Measurement uncertainty

The following values of measurement uncertainty (or better) associated with each measurement parameter apply to all of the test cases described in this TBR:

Electrical signal power	$\pm 0,2$ dB for levels $\geq 50$ dBm
Electrical signal power	$\pm 0,4$ dB for levels $< - 50$ dBm
Sound pressure	$\pm 0,5$ dB
Time	$\pm 5$ %
Frequency	$\pm 2$ %

NOTE: When measuring sampled systems, it is advisable to avoid measuring at multiples of the sampling frequency. A tolerance of  $\pm 2$  % of the frequencies, may be used to avoid this problem, except at 4 kHz where only the  $- 2$  % tolerance may be used.

The measurement uncertainty is defined as the combined effects of all sources of errors at a confidence level of at least 95 %.

## 5.4 Upper Tester (UT)

### 5.4.1 Description of the UT

The UT is part of, but not necessarily restricted to, the EUT. For the purpose of testing, an EUT capable of transmitting shall recognise a mandatory set of test commands sent by the LT. The ability to recognise and implement these commands is contained in the UT which is resident in the medium access control layer as described in ETS 300 175-3 [3], and as modified by Clause 18 of TBR 6 [22]. All DECT equipment shall be capable of recognising these commands. An EUT which is declared as implementing the Test Support Profile shall implement the provisions of the Test Support Profile described in TBR 6 [22] Annex D. The implementation of the Test Support Profile is not mandatory.

### 5.4.2 The test standby mode

Accessibility to these messages is controlled by some means of mechanical interlocking method or manual switching (e.g. dip-switch, jumper, prom, or key-pad code as designated by the applicant) to prevent accidental execution of these messages in a DECT user environment.

When the EUT has been switched into a mode whereby the test messages are accessible, the EUT is said to be in the speech test standby mode, whereby the complete speech path is open in the EUT.

### 5.4.3 Test messages

The MAC layer test messages shall provide the following functions:

- a) instruct the EUT to transmit on a LT-specified physical channel. The test message also determines whether the handover function of the EUT (if so equipped) is disabled and if previous bearers are to be maintained. See subclauses 7.2.5.4.2 and 12.3 of ETS 300 175-3 [3];

- b) instruct the EUT to perform the loopback function in which a test data pattern transmitted by the LT is replicated in the reply transmission of the EUT (see subclauses 7.2.5.4.3 and 12.4 of ETS 300 175-3 [3]). The test data pattern is a bit sequence located in the D-fields of the LT and EUT. The bits of the D-field that are affected by the loopback function depends on the equipment type and are as follows:

Equipment type	Loopback Bits
Transmits only A-field:	a <sub>16</sub> to a <sub>47</sub>
Transmits half-slots:	b <sub>0</sub> to b <sub>79</sub>
Transmits full-slots:	b <sub>0</sub> to b <sub>319</sub>
Transmits double-slots:	b <sub>0</sub> to b <sub>799</sub>

Equipment capable of transmitting more than one slot type shall use the longest slot type for this test message;

- c) defeat antenna diversity and select the specified antenna for operation in those EUTs possessing antenna diversity. See subclauses 7.2.5.4.4 and 12.5 of ETS 300 175-3 [3];
- d) initiate the bearer handover procedure resident in an EUT that is declared by the applicant as possessing bearer handover capability. See subclauses 7.2.5.4.5 and 12.6 of ETS 300 175-3 [3];
- e) permit inclusion of proprietary test messages by means of the "escape" code. See subclauses 7.2.5.4.6 and 12.8 of ETS 300 175-3 [3];
- f) provide for a means to reset the test state of the EUT by means of the "clear test modes" message. See subclauses 7.2.5.4.8 and 12.9 of ETS 300 175-3 [3].

The test messages used explicitly in this document are described in b) and f).

## 6 Test conditions, power sources and ambient temperatures

### 6.1 General

The following conditions shall apply during all tests:

Temperature uncertainty:	± 1 °C
Atmospheric pressure:	86 to 106 kPa
Relative humidity:	20 % to 75 % non-condensing
Humidity uncertainty:	± 10 %

The temperature conditions applied in each test are specified as nominal. The definition of nominal is contained in subclause 1.

The sequence of measurements shall be chosen, and the humidity content in the test chamber shall be controlled, so that condensation does not occur.

When it is impractical to carry out the tests under these conditions, a statement giving the actual temperature and relative humidity during the tests shall be added to the test report.

### 6.2 Nominal test conditions

Each measurement shall be made at the temperature of the test site, which shall be within +15 to +35°C.

### 6.3 Power source

The EUTs battery or mains power supply (whichever is appropriate) shall be used throughout the tests.

## 7 Speech and telephony tests

### 7.1 Test configurations

#### 7.1.1 General

A DECT system comprises a PP and a FP. As these parts are not always purchased together, it shall be a requirement that either the complete system or each of the two separate parts shall be capable of being tested. However, a PP, together with a reference FP (ReFP), or a FP, together with a reference PP (RePP), can be considered to represent the relevant characteristics of the complete system. ReFP and RePP referred to in the following subclauses, are part of the LT described in subclause 1.

#### 7.1.2 Testing a DECT system

Complete system tests involve the two-way transmission between the acoustic input and output of a PP and a digital S reference point of a FP. This situation is the same as in ETS 300 085 [9], and as far as possible the same testing methods and testing equipment are used. The general test methods described in subclause 1 are applicable except that the ReFP and the RePP are replaced by a FP or a PP of the DECT system, unless otherwise stated. EUTs supplied as a DECT system shall only be tested and approved as a complete DECT system.

#### 7.1.3 Testing a separate PP or FP

If an LT is available that can establish a speech connection with the EUT and the EUT supports, where required, the <<TERMINAL CAPABILITY>> information element as described in subclause 7.7.41 of ETS 300 175-5 [5] then approval of a FP or a PP as a separate item is allowed.

NOTE: Inter-operability between EUTs that are approved separately is only feasible if they use the same profile.

The performance of the PP shall be measured by means of a Reference Fixed Part, (ReFP). The performance of the FP shall be measured by means of a Reference Portable Part, RePP.

The ReFP and RePP shall provide the equivalent of true air interface measurements and therefore shall not contain circuitry which will modify the true air interface speech frequency performance. To meet these requirements, measurements shall be referred to a uniform PCM reference point. The CCITT Recommendation G.726 [10] at 32 kbit/s algorithm requires such a uniform interface, although in the case of DECT it may not be physically available.

The transcoding algorithms are specified such that encoding and decoding are symmetrical, i.e. with an encoder and decoder connected in tandem, the "levels" of the digital signals at the uniform PCM input to the encoder and output from the decoder are identical. Once the speech channel signals are in the digital domain they are essentially lossless and hence the level at the air interface can be related to any digital interface.

Ideally, to measure the send signals from the PP at the air interface, a PCM level meter should be connected to the reference decoder uniform PCM output, and to generate receive signals for the PP at the air interface, a PCM signal generator should be connected to the reference encoder uniform PCM input.

A more practical means of measuring the speech channel performance may be achieved by converting the uniform PCM to standard  $\mu$  or A law PCM and then using a standard PCM test set and applying the appropriate correction factor as defined in CCITT Recommendations G.711 [18] and G.726 [10] at 32 kbit/s, (although this could have a negative effect on some parameters such as distortion).

Two possible general test methods are described here. The first is commonly called the direct digital processing approach. In this approach, the digital bit-stream is operated upon directly. See figure 3.

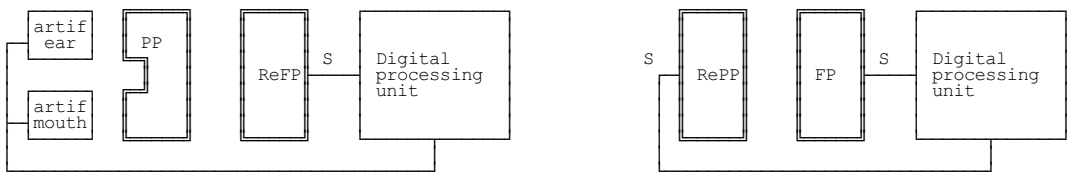

**Figure 3: The direct digital processing approach test configurations for a separate PP and a separate FP**

The second measurement method involves the use of an ideal codec. In this case, a codec is used to convert the digital bit-stream to the equivalent analogue value, so that existing test procedures and existing analogue measuring equipment can be used. See figure 4.

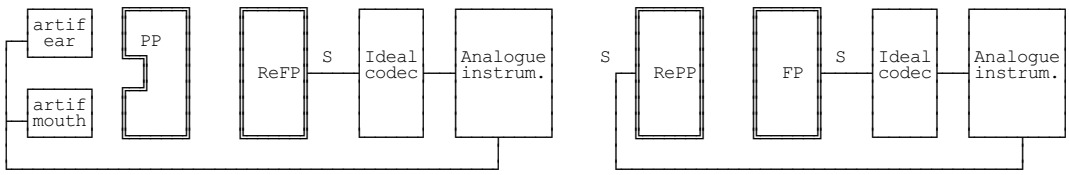

**Figure 4: The ideal codec approach. Test configuration for a separate PP and a separate FP**

**7.1.4 Reference FP, ReFP, and reference PP, RePP**

A ReFP and RePP are shown in figures 3 and 4, and they incorporate the specified transcoder algorithm as described in CCITT Recommendation G.726 [10] at 32 kbit/s.

Both the Reference FP and the Reference PP shall have the ability to loopback the ADPCM signal with a 5 ms delay.

NOTE: This 5 ms delay corresponds to the delay between the receive and transmit timeslots of a duplex bearer.

The Reference PP shall have a value of TCLw of 36 dB ± 2 dB.

The uniform PCM reference points, points C and D in figure 5, are those designated SL and SR in CCITT Recommendation G.726 [10] at 32 kbit/s.

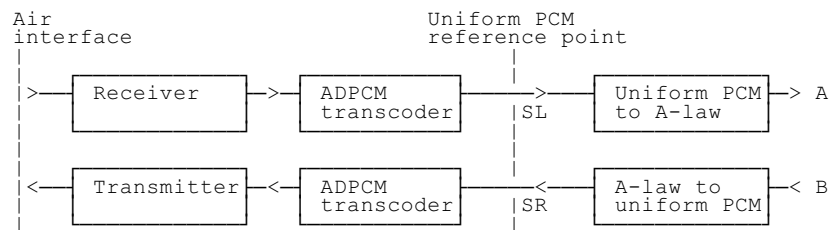

**Figure 5: Reference FP and PP**

### 7.1.5 Applicability of tests

This subclause indicates whether each test is applicable to the PP, FP or to the system (PP and FP combined). It is intended for information only.

**Table 1:**

Subclause Number of Test	Applicable to		
	PP	FP	System
7.6	█	█	█
7.7	█		█
7.8	█		█
7.9	█		█
7.10	█		█
7.11	█		█
7.12	█		█
7.13	█		█
7.14	█	█	█
7.15	█		█
7.16	█		█
7.17	█		█
7.18	█		█
7.19	█		█
7.20	█		█
7.21	█		█
7.22	█		█
7.23	█		█
7.24	█		█
7.25	█		█
7.26	█		█
7.27	█		█
7.28	█		█
7.29	█	█	█
7.30	█		█
7.31	█		█
7.32	█		█

Annex A provides a summary of the essential requirement Articles of the Terminal Directive [28] justifying the tests in this TBR.

### 7.2 Digital signal level

The "level" of the digital signal at the uniform companded PCM and ADPCM interfaces are defined in dBm0. A 1 kHz sine wave whose peak signal corresponds with the maximum PCM code is assigned a level of + 3,14 dBm0 (CCITT Recommendation G.711 [18]).

The relationship between the PCM encoding law and the audio signal level is defined in CCITT Recommendation G.711 [18]. The theoretical load capacity of CCITT Recommendation G.726 [10] at 32 kbit/s ADPCM is the same as for A-law PCM.

For sensitivity and loudness rating calculations the nominal voltage assigned to a digital signal is calculated assuming an associated impedance of 600  $\Omega$ . Thus 0 dBm0 is equivalent to a voltage of - 2,2 dBV.

The digital line interface is a 0 dBr point in accordance with CCITT Recommendation G.101 [26]. As the various digital transcoding algorithms are essentially loss-less, the relative level is constant over the whole digital path in the PP and the FP.

**7.3 General conditions of test**

Unless otherwise stated, the tests are made under the normal operating conditions specified in subclause 2.

The PP or FP under test shall be tested in conjunction with the ReFP or the RePP respectively, separated by some unobstructed distance, between 2 m and 10 m, in a room with an ambient sound noise level of less than - 64 dBPa(A). In addition, the room shall be a relatively noiseless RF environment such that the normal handshaking between FP and PP is maintained. A connection shall be established and maintained for a two-way speech transmission.

Unless otherwise stated in a particular test, where the PP under test has fixed geometry, the PP shall be placed in the LRGP as described in CCITT Recommendation P.64 [16], Annex C . Where the PP has variable geometry, the front plane of the mouthpiece shall be mounted 15 mm in front of the lip ring and coaxial with the artificial mouth. A PP with variable geometry, having a natural position during on-line conditions shall be regarded as being a fixed geometry PP.

The tests defined in subclauses 7.14 and 7.30, regarding echoes, are defined for steady states. It shall be possible to disable every echo control function implemented in the FP. The applicant shall declare to the test laboratory how this is done.

Unless otherwise stated, if a user-controlled volume control is provided at the PP, the requirements apply for all positions of the volume control, and the compliance tests shall be carried out at the maximum setting of this volume control.

NOTE: CCITT Recommendation P.64 [16] allows the use of alternative signal sources for measurements of loudness ratings. If such a signal source is used, it is the responsibility of the test laboratory to ensure that the method used can obtain equivalent results.

**7.4 Ideal codec**

The ideal codec approach uses a codec to convert the companded digital bit stream to the equivalent analogue values, so that existing test equipment and procedures may be used. This codec shall be a high quality codec whose characteristics are close to ideal. The codec shall have characteristics such as attenuation/frequency distortion, idle channel noise, quantising distortion etc. which exceed the reference codec requirements specified in CCITT Recommendation O.133 [27], Clause 4 so as not to mask the corresponding parameters of the apparatus under test. The linear A/D and D/A convertors used by the codec shall have at least 14 bit resolution, and the filter response shall lie within the upper and lower limits given in table 2.

**Table 2: Frequency/sensitivity response of an ideal codec**

	Frequency Hz	Loss dB
Lower limit	0	0,0
	80	0,0
	80	- 0,25
	3 600	- 0,25
	3 600	0,0
Upper limit	4 000	0,0
	100	+ 40,0
	100	+ 0,25
	3 000	+ 0,25
	3 000	+ 0,9
	3 400	+ 0,9
3 400	+ 40,0	

The limit curves shall be determined by straight lines joining successive co-ordinates given in table 2, when the loss is plotted on a linear axis against frequency on a logarithmic axis.

## **7.5 Electro-acoustical equipment**

The artificial mouth and the artificial ear shall conform to CCITT Recommendations P.51 [15] and P.57 [19].

The sound level meter shall conform to IEC 651 [24], type 1.

## **7.6 Speech coding scheme**

### **7.6.1 Requirement for speech coding algorithm**

The speech coding algorithm shall conform to CCITT Recommendation G.726 [10] at 32 kbit/s, for 32 kbit/s ADPCM.

The A-law companding and synchronous tandem adjustment may be omitted in FPs with an analogue line interface and in PPs.

NOTE: CCITT Recommendation G.726 [10] at 32 kbit/s codecs support the use of the voice channel for telefax of group 2 and group 3. For group 3 the data speed, which is automatically negotiated, shall be limited to 4,8 kbit/s.

The ADPCM words comprised in each burst shall be transmitted in chronological order, and with the most significant bit transmitted first within each word.

### **7.6.2 Applicant's declaration on speech coding algorithm**

For these highly integrated products, it is not intended to require a PCM interface (uniform or logarithmic) for testing purposes only. Compliance shall be by applicant's declaration (see subclause 1).

### **7.6.3 Requirement for the digital PCM interface in the FP**

The digital PCM interface of the FP shall be equivalent to the PCM interface of the speech coding algorithm.

### **7.6.4 Applicant's declaration on the digital PCM interface in the FP**

The applicant shall declare that the digital PCM interface of the FP is equivalent to the PCM interface of the speech coding algorithm.

## 7.7 PP sending frequency response

### 7.7.1 Requirement

The sending sensitivity/frequency response (from MRP to the digital interface) shall be within a mask as defined in the following table:

**Table 3: Sending sensitivity-frequency mask**

Frequency (Hz)	Upper limit (dB)	Lower limit (dB)
100	- 12	
200	0	
300	0	- 14
1 000	0	- 8
2 000	4	- 8
3 000	4	- 8
3 400	4	- 11
4 000	0	

NOTE: All dB levels are on an arbitrary scale.

### 7.7.2 Method of measurement

The handset shall be mounted in the LRGP (see CCITT Recommendation P.64 [16] Annex C), and the earpiece sealed to the knife-edge of an artificial ear.

A pure tone signal of - 4,7 dBPa shall be applied at the MRP as described in CCITT Recommendation P.64 [16], using an artificial mouth conforming to CCITT Recommendation P.51 [15].

A digital measuring instrument, or an ideal codec followed by an analogue level measuring set, shall be connected to point A of the ReFP as shown in figure 5, or to the S-reference point of a FP.

Measurements shall be made at one twelfth-octave intervals as given by the R40 series of preferred numbers in ISO 3 [20] for frequencies from 100 Hz to 4 kHz inclusive. At each frequency the level for an input sound pressure of - 4,7 dBPa shall be measured.

## 7.8 PP receiving frequency response

See subclause 7.1.2 of ETS 300 175-8 [8].



### 7.8.1 Requirement

The receiving sensitivity-frequency response (from the digital interface to the ERP) shall be within a mask as defined in the following table:

**Table 4: Receiving sensitivity-frequency mask**

Frequency (Hz)	Upper limit (dB)	Lower limit (dB)
100	- 12	
200	0	
300	2	- 9
500	NOTE 1	- 7
1 000	0	- 7
3 000	2	- 7
3 400	2	- 12
4 000	2	
NOTE 1: The limit at intermediate frequencies lies on a straight line drawn between the given values on a log (frequency) - linear (dB) scale.		
NOTE 2: All dB levels are on an arbitrary scale.		

### 7.8.2 Method of measurement

A digital signal generator, or an analogue signal generator followed by an ideal codec, shall be connected to point B of the ReFP as shown in figure 5, and the level shall be adjusted to produce a level of - 16 dBm0 at the uniform PCM reference point.

Measurements shall be made at one twelfth-octave intervals as given by the R40 series of preferred numbers in ISO 3 [20] for frequencies from 100 Hz to 4 kHz inclusive. At each frequency, the sound pressure level in the artificial ear shall be measured.

## 7.9 PP loudness rating

### 7.9.1 Requirement

The nominal values are: Sending Loudness Rating ( $SLR_H$ ) = 7 dB and Receiving Loudness Rating ( $RLR_H$ ) = 3 dB. The  $SLR_H$  shall be 7 dB  $\pm$  3,5 dB. The  $RLR_H$  shall be 3 dB  $\pm$  3,5 dB.

### 7.9.2 Method of measurement

#### 7.9.2.1 $SLR_H$

A digital measuring instrument, or an ideal codec followed by an analogue level measuring set, shall be connected to point A of the ReFP as shown in figure 5, or to the S-reference point of a FP.

The handset shall be mounted as described in subclause 7.7.2. The sending sensitivity shall be measured at each of the 14 frequencies given in table 1 of CCITT Recommendation P.79 [17], bands 4 - 17.

The sensitivity shall be expressed in terms of dBV/Pa and the  $SLR$  shall be calculated according to CCITT Recommendation P.79 formula 2.1 [17], over bands 4 to 17, using  $m = 0,175$  and the sending weighting factors from CCITT Recommendation P.79 [17] table 1.

#### 7.9.2.2 $RLR_H$

A digital measuring instrument, or an ideal codec followed by an analogue level measuring set, shall be connected to point A of the ReFP as shown in figure 5, or to the S-reference point of a FP.

The handset shall be mounted as described in subclause 7.7.2. The receiving sensitivity shall be measured at each of the 14 frequencies listed in Table 1 of CCITT Recommendation P.79 [17], bands 4 - 17.

The sensitivity shall be expressed in terms of dBPa/V and the  $RLR$  shall be calculated according to CCITT Recommendation P.79 [17] formula 2.1, over bands 4 to 17, using  $m = 0,175$  and the receiving weighting factors from table 1 of this Recommendation.

The artificial ear sensitivity shall be corrected using the real ear correction of table 2 of CCITT Recommendation P.79 [17].

## 7.10 User Controlled Volume control in the PP

### 7.10.1 Requirement

Where user controlled volume controls are provided the  $RLR_H$  and  $SLR_H$  shall simultaneously meet the values given in subclause 7.9.1, including the tolerances, for at least one setting of the volume control. This setting shall be defined as the nominal setting.

A "Joint Acting" Volume Control is where the PP can simultaneously change the values of SLR and RLR in opposite directions.

The  $RLR_H$  and  $SLR_H$  shall not exceed the limits given in the following tables.

**Table 5: Absolute limits for "joint-acting" volume control**

Volume setting	Maximum	Minimal
$RLR_H$	- 13 dB	19 dB
$SLR_H$	17 dB	3 dB

**Table 6: Absolute limits for a receiving volume control**

Volume setting	Maximum	Minimal
$RLR_H$	- 13 dB	19 dB

### 7.10.2 Method of measurement

#### 7.10.2.1 $SLR_H$

The method of measurement and test conditions shall be as laid down in subclause 1.

#### 7.10.2.2 $RLR_H$

The method of measurement and test conditions shall be as laid down in subclause 1.

## 7.11 PP talker sidetone masking rating

### 7.11.1 Requirement

The sidetone path shall be implemented in the PP.

The nominal value of the SideTone Masking Rating (STMR) shall be 13 dB. The value of the STMR shall be 10 - 18 dB referred to nominal values of  $SLR_H$  and  $RLR_H$  ( $SLR_H = 7$  dB and  $RLR_H = 3$  dB).

### 7.11.2 Method of measurement

For the test the digital input in the receiving direction shall be driven by a signal corresponding to PCM decoder value number 1.

Where a user controlled volume control is provided, the measurements shall be carried out at a setting which shall be as close as possible to the nominal value of the RLR ( $RLR = 3$  dB).

The handset shall be mounted in the LRGP and the earpiece shall be sealed to the knife-edge of the artificial ear. A pure tone signal of - 4,7 dBPa shall be applied at the mouth reference point. For each frequency given in CCITT Recommendation P.79 [17] table 3, bands 1 to 20, the sound pressure in the artificial ear shall be measured.

The sidetone path loss  $L_{meST}$  as expressed in dB and the STMR (in dB) shall be calculated from the formula 2.1 of CCITT Recommendation P.79 [17], using  $m = 0,225$  and the weighting factors in table 3 of CCITT Recommendation P.79 [17].

## **7.12 Listener SideTone**

### **7.12.1 LSTR requirement**

The value of the LSTR shall not be less than 10 dB referred to the nominal values of  $SLR_H$  and  $RLR_H$ .

For PPs with noise rejection capability as declared by the applicant, the value of the LSTR shall not be less than 15 dB referred to the nominal values of  $SLR_H$  and  $RLR_H$ .

### **7.12.2 Protocol requirement for EUTs with declared noise rejection capability**

The FP shall know whether or not the PP has implemented the noise rejection capability before or at call set-up.

### **7.12.3 Method of measurement for LSTR**

The diffuse sound field shall be calibrated in the absence of any local obstacles. The averaged field shall be uniform to within  $\pm 3$  dB within a radius of 0,15 m of the MRP, when measured in one-third octave bands from 100 Hz to 8 kHz (bands 1 to 20).

NOTE 1: The pressure intensity index as defined in ISO Publication 9614 [33] may prove to be a suitable method for assessing the diffuse field.

NOTE 2: Where more than one loudspeaker is used to produce the desired sound field, the loudspeakers may require to be fed with non-coherent electrical signals to eliminate standing waves and other interference effects.

Where a user controlled volume control is provided, the measurements shall be carried out at a setting which shall be as close as possible to the nominal value of the RLR ( $RLR = 3$  dB).

A calibrated half-inch microphone shall be mounted at MRP. The sound field shall be measured in one-third octave bands. The spectrum shall be "Hoth" as defined in CCITT Revised Recommendation P.80 [23] to within  $\pm 1$  dB and the level shall be adjusted to - 44 dBPa(A). The tolerance on this level shall be  $\pm 1$  dB.

NOTE 3: Where adaptive techniques or voice switching circuits are not used, it is recommended to increase the sound level to - 34 dBPa(A) to improve measurement accuracy.

The artificial mouth and ear shall be placed in the correct position relative to MRP, the handset shall be mounted at LRGP and the earpiece shall be sealed to the knife-edge of the artificial ear.

Measurements shall be made in one-third octave bands for the 20 bands centered at 100 Hz to 8 kHz (bands 1 to 20). For each band the sound pressure in the artificial ear shall be measured by connecting a suitable measuring set to the artificial ear.

The listener sidetone path loss shall be expressed in dB and the LSTR shall be calculated from the CCITT Recommendation P.79 [17] formula 2.1, using  $m = 0,225$  and the weighting factors in table 3 of the Recommendation.

### **7.12.4 Method of measurement for the Protocol Requirement for EUTs with declared noise rejection capability applying to be approved separately**

Subclause 2 clarifies which EUTs are applicable to this subclause.

- a) The LT shall request the PP to make an outgoing call using the test message described in subclause 1;

- b) the LT shall verify that the <<TERMINAL CAPABILITY>> information element is included in the CC-SETUP message and that it indicates correctly whether the PP ambient noise rejection capability has been implemented. See subclause 7.7.41 of ETS 300 175-5 [5].

### **7.12.5 Applicant's declaration for the protocol requirement for EUTs applying to be approved as a DECT system**

Subclause 1 clarifies which EUTs are applicable to this subclause.

The applicant shall declare one of the following:

- 1) all PPs in the DECT system have identical noise rejection capability and this is known at all FPs; or
- 2) PPs indicate to the FP at call set-up whether they have implemented the noise rejection capability by some protocol means that the FP understands.

### **7.13 Terminal Coupling Loss of a PP**

#### **7.13.1 TCLw requirement**

The weighted Terminal Coupling Loss (TCLw) defined from the PP digital input to the PP digital output shall meet one of the following options:

- a)  $TCLw > 46$  dB at nominal setting of the volume control corrected to the nominal values of  $RLR_H$  and  $SLR_H$ . For all positions of volume control the TCLw shall not be less than 35 dB;

NOTE: This is the recommended option.

- b)  $TCLw > 34$  dB.

If the PP is designed to meet option a), this option shall be declared by the applicant.

#### **7.13.2 Protocol requirement**

The FP shall know if TCLw option a) has been implemented in the PP.

#### **7.13.3 Method of measurement for TCLw for a PP being approved separately**

The PP shall be suspended in free air.

- a) A digital signal generator, or an analogue signal generator followed by an ideal codec, shall be connected to point B of the ReFP as shown in figure 5;
- b) the signal generator shall be set to provide a signal level of -10 dBm0 at the uniform PCM point D of figure 5;
- c) the PP shall be suspended in free air in a low noise room(see subclause 5.2) in such a way that the inherent mechanical coupling of the handset shall not be affected;
- d) the level at the uniform PCM reference point, point C of figure 5, shall be evaluated using the level meter for one twelfth-octave intervals as given by the R40 series of preferred numbers in ISO 3 [20] for frequencies 300 Hz to 3 400 Hz;
- e) the (TCLw), shall be calculated according to CCITT Recommendation G.122 [11] Annex B4, Trapezoidal rule.

#### **7.13.4 Method of measurement for TCLw for a PP being approved as part of a DECT system**

- a) Disable any artificial echo loss or echo control device;

- b) a digital signal generator, or an analogue signal generator followed by an ideal codec, shall be connected to the S-reference point of the FP;
- c) parts b), c), d) and e) in subclause 1 are repeated.

#### **7.13.5 Method of measurement for the protocol requirement for EUTs applying to be approved separately**

Subclause 3 clarifies which EUTs are applicable to this subclause. This requirement does not apply if the PP implements minimum TCLw (option b)).

- a) The LT shall request the PP to make an outgoing call using the test message described in subclause 2;
- b) the LT shall verify that the <<TERMINAL CAPABILITY>> information element is included in the CC-SETUP message and that it indicates correctly whether full TCLw (option a)) has been implemented. See subclause 7.7.41 of ETS 300 175-5 [5].

#### **7.13.6 Applicant's declaration for the protocol requirement for EUTs applying to be approved as a DECT system**

Subclause 4 clarifies which EUTs are applicable to this subclause. This requirement does not apply if the PP implements minimum TCLw (option b)).

The applicant shall declare one of the following:

- 1) all PPs in the DECT system have full TCLw implemented and this is known at all FPs; or
- 2) PPs indicate to the FP at call set-up whether they have implemented full TCLw by some protocol means that the FP understands.

### **7.14 FP echo control functions with a 4-wire interface**

#### **7.14.1 Static requirements**

If the EUT (FP) is part of a DECT System (see subclause 2) where the PP implements minimum TCLw (see subclause 1) or the EUT is being approved as a separate item (see subclause 5) then the EUT shall implement one of the two following alternatives:

- a) artificial echo loss. See subclause 1;
- b) echo control device. See subclause 1.

However, if the EUT (FP) is being approved as part of a DECT System (see subclause 3) where the PP always implements full TCLw then artificial echo loss and an echo control device shall not be implemented or shall be disabled and the requirements in subclauses 2 and 2 do not apply.

#### **7.14.2 Dynamic requirements**

##### **7.14.2.1 Minimum TCLw**

If the FP receives no information concerning the TCLw value of the PP, the FP shall default to the assumption that the PP fulfils option b) of subclause 7.13.1 and it shall enable either an artificial echo loss or an echo control device. Routing information as described in subclause 7.4.1.2 of ETS 300 175-8 [8] shall not be available during the test.

NOTE: Installed DECT equipment may disable the functions a) or b) e.g. internal calls, local calls or non-speech services as described in subclause 7.4.1.2 of ETS 300 175-8 [8].

### 7.14.2.2 Full TCLw

For FPs that are approved separately, then receipt of the <<TERMINAL CAPABILITY>> information element indicating full TCLw shall disable any artificial echo loss or echo control device.

For FPs that are being approved as part of a DECT System with PPs in the system implementing both Minimum TCLw and full TCLw then the FP shall, on receipt of a full TCLw indication message, disable any artificial echo loss or echo control device.

### 7.14.3 Artificial echo loss of a FP with a 4-wire interface

#### 7.14.3.1 Requirement for artificial echo loss

An artificial echo path shall be implemented into the FP between the line input and the line output, as shown in figure 6. The loss of that echo path shall be 24 dB  $\pm$  2 dB.

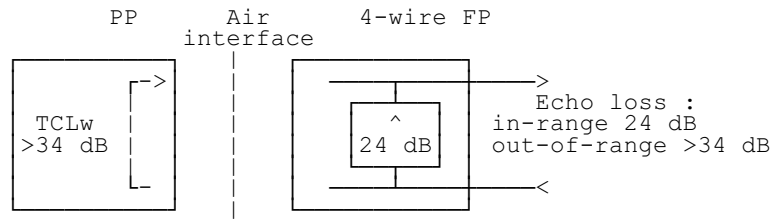

Figure 6: Artificial echo path in a 4-wire FP

#### 7.14.3.2 Requirement for the ability to disable the artificial echo loss

This requirement shall be applicable to all FPs approved as separate items and FPs approved as part of a DECT System where all PPs do not have TCLw > 46 dB.

The FP shall disable the artificial echo loss on receipt of a protocol message from the PP indicating full TCLw.

#### 7.14.3.3 Method of measurement of artificial echo loss

The FP shall have its artificial echo path activated and the speech path via the air interface de-activated. Any echo control device as specified in subclause 3 shall be disabled.

A digital signal generator, or analogue signal generator followed by an ideal codec shall be connected to point B of the ReFP as shown in figure 5 or to the S-interface of the FP.

The signal generator shall be set to provide a signal level of 0 dBm0 at the input of the S-interface.

The level at the output of the S-interface shall be evaluated using the level meter for one twelfth-octave intervals as given by the R40 series of preferred numbers in ISO 3 [20] for frequencies 300 Hz to 3 400 Hz.

The artificial echo loss shall be calculated according to CCITT Recommendation G.122 [11].

#### 7.14.3.4 Method of measurement for ability to disable artificial echo loss

##### 7.14.3.4.1 EUTs being approved as separate items

- 1) The LT shall set-up a call with the EUT by sending a CC-SETUP message containing the <<TERMINAL CAPABILITY>> information element as described in subclause 7.7.41 in ETS 300 175-5 [5], indicating full TCLw;
- 2) repeat the test described in subclause 1;
- 3) the artificial echo loss shall be greater than 34 dB.

#### **7.14.3.4.2 EUTs being approved as a DECT system with a PP having full TCLw**

- 1) The PP of the DECT System shall be used to set-up a call, with a full TCLw indication, with the EUT;
- 2) repeat the test described in subclause 2;
- 3) the artificial echo loss shall be greater than 46 dB.

#### **7.14.4 Echo control device of a FP with a 4-wire interface**

##### **7.14.4.1 Requirement for the echo control device**

An echo control device shall be implemented into the FP. The TCLw of the DECT system, defined from the FP line input to the FP line output, shall be at least 46 dB.

##### **7.14.4.2 Requirement for the ability to disable the echo control device**

This requirement shall be applicable to all FPs approved as separate items and FPs approved as part of a DECT System where all PPs do not have TCLw > 46 dB.

The FP shall disable the artificial echo loss on receipt of a protocol message from the PP indicating full TCLw.

##### **7.14.4.3 Method of measurement for the echo control device**

The FP shall have its echo control device activated and no activated artificial echo path.

A digital signal generator, or analogue signal generator followed by an ideal codec shall be connected to point B of the ReFP as shown in figure 5 or to the S-interface of the FP.

The signal generator shall be set to provide a signal level of 0 dBm0 at the input of the S-interface.

The input of the S-interface at the RePP shall be connected to the output of the S-interface at the RePP with a 34 dB loss.

The level at the output of the S-interface at the FP shall be evaluated using the level meter for one twelfth octave intervals as given by the R40 series of preferred numbers in ISO 3 [20] for frequencies 300 Hz to 3 400 Hz.

The TCLw shall be calculated according to CCITT Recommendation G.122 [11] Annex B4, Trapezoidal rule.

##### **7.14.4.4 Method of measurement for the ability to disable the echo control function**

###### **7.14.4.4.1 EUTs being approved as separate items**

- 1) The LT shall set-up a call with the EUT by sending a CC-SETUP message containing the <<TERMINAL CAPABILITY>> information element as described in subclause 7.7.41 in ETS 300 175-5 [5], indicating full TCLw;
- 2) repeat the test described in subclause 1;
- 3) the TCLw shall be less than 46 dB.

###### **7.14.4.4.2 EUTs being approved as a DECT system with a PP having full TCLw**

- 1) The PP of the DECT System shall be used to set-up a call, with a full TCLw indication, with the EUT;
- 2) repeat the test described in subclause 7.13.4.

- 3) the TCLw shall be as measured in subclause 7.13.4.

## **7.15 Stability loss - fixed geometry**

### **7.15.1 Requirement**

The attenuation from the digital input to the digital output shall be at least 6 dB at all frequencies in the range of 200 Hz to 4 000 Hz.

### **7.15.2 Method of measurement**

- a) With the digital signal generator, or the analogue signal generator, followed by an ideal codec, set to provide a signal level of -10 dBm<sub>0</sub> at the uniform PCM point B of figure 5, the attenuation from the input B to the output A shall be measured at one-twelfth octave intervals for frequencies in the range 200 Hz to 4 000 Hz under the conditions in b).
- b) The PP shall be placed on one inside surface of three perpendicular plane smooth hard surfaces forming a corner. Each corner shall extend 0,5 m from the apex of the corner. One surface shall be marked with a diagonal line extending from the corner and a reference position marked on the line 250 mm from the corner.

The PP shall be positioned centrally along the diagonal line with the earcap nearer to the apex of the corner such that:

- 1) the mouthpiece and earcap shall face towards the surface; and
- 2) the extremity of the PP shall coincide with "the normal to the reference point".

## **7.16 Stability loss variable geometry**

### **7.16.1 Requirement**

The attenuation from the digital input to the digital output shall be at least 6 dB at all frequencies in the range of 200 Hz to 4 000 Hz.

### **7.16.2 Method of measurement**

The equipment shall meet the requirement in at least one of the two following conditions:

- a) if the movement and orientation of the acoustic elements are fixed by means of a hinge or similar mechanism while the PP is active, the requirement shall be met for these fixed positions. The measurement shall be carried out in the corner described under point b) of subclause 7.15.2. In the just off-hook position the measurement shall be carried out under free field conditions;
- b) if the movement and orientation of the acoustic elements are not fixed while the PP is active, the requirement shall be met for any position and orientation that can be achieved. The measurement shall be carried out in the corner described under point b) of subclause 7.15.2.

With the digital signal generator, or the analogue signal generator followed by an ideal codec, set to provide a signal level of 0 dBm<sub>0</sub> at the uniform PCM point D of figure 5, the attenuation from the input B to the output A shall be measured at one twelfth octave intervals for frequencies in the range 200 Hz to 4 000 Hz.

## **7.17 Sending distortion**

### **7.17.1 Requirement**

The ratio of signal to total distortion (harmonic and quantising) measured at the line interface shall not be less than 33 dB.



### 7.17.2 Method of measurement

NOTE: The test methods defined in ETS 300 085 [9] are inappropriate when ADPCM coding is used. A provisional method of measurement is therefore provided. A more general method of measurement is under study.

A pure tone signal of - 4,7 dBPa and nominal frequency between 1 004 Hz and 1 025 Hz shall be applied at the MRP as described in CCITT Recommendation P.64 [16], using an artificial mouth conforming to CCITT Recommendation P.51 [15].

A digital measuring instrument, or an ideal codec followed by an analogue level measuring set, shall be connected to point A of the ReFP as shown in figure 5 or to the S-reference point of a FP.

The ratio of the signal to total distortion power at the output A shall be measured with the psophometric noise weighting as described in CCITT Recommendations G.714 [14] and O.132 [12].

### 7.18 Receiving distortion

#### 7.18.1 Requirement

The ratio of signal to total distortion (harmonic and quantising) measured at the ERP shall not be less than 33 dB.

#### 7.18.2 Method of measurement

NOTE: A more general method of measurement is under study.

A digital signal generator, or an analogue signal generator, followed by an ideal codec, shall be connected to point B of the ReFP, as shown in figure 5, or to the S-reference point of a FP, and the level shall be adjusted to produce a digitally simulated sine-wave of nominal frequency between 1 004 Hz and 1 025 Hz at a level of - 10 dBm0 at the uniform PCM reference point D.

The ratio of signal to total distortion power of the signal output in the artificial ear shall be measured with the psophometric noise weighting. See figures 3 and 4 and CCITT Recommendations G.714 [14] and O.132 [12].

### 7.19 Side tone distortion

#### 7.19.1 Requirement

The third harmonic distortion generated by the PP shall not be greater than 10 %.

#### 7.19.2 Method of measurement

The PP shall be mounted at the LRGP and the earpiece shall be sealed to the knife-edge of the artificial ear. An instrument capable of measuring the third harmonic distortion of signals with fundamental frequencies in the range of 315 Hz to 1 000 Hz shall be connected to the artificial ear.

A pure-tone signal of - 4,7 dBPa shall be applied at the mouth reference point at frequencies of 315 Hz, 500 Hz and 1 000 Hz. For each frequency, the third harmonic distortion shall be measured in the artificial ear.

### 7.20 Out of band (sending)

#### 7.20.1 Requirement

With any sine-wave signal above 4,6 kHz and up to 8 kHz applied at the MRP at a level of - 4,7 dBPa, the level of any image frequency produced at the digital interface shall be below a reference level obtained at 1 kHz (- 4,7 dBPa at MRP) by at least the amount in dB specified in the following table.

**Table 7: Discrimination levels - sending**

Boundaries of signal frequencies	Limit (minimum)
4,6 kHz	30 dB
8 kHz	40 dB

The limits at intermediate frequencies lie on a straight line drawn between the given values on a log (frequency) - linear (dB) scale.

**7.20.2 Method of measurement**

- a) A digital measuring instrument, or an ideal codec followed by an analogue level measuring set, shall be connected to point A of the ReFP as shown in figure 5 or to the S-reference point of a FP;
- b) a pure sine wave of level - 4,7 dBPa shall be applied at the MRP;
- c) for applied frequencies of 4,65, 5,0, 6,0, 6,5, 7,0, and 7,5 kHz, the level of the corresponding image frequency shall be measured.

**7.21 Out of band (receiving)**

**7.21.1 Requirement**

With a digitally-simulated sine-wave signal in the frequency range of 300 Hz to 3 400 Hz at a level of -10 dBm0 applied at the digital interface, the level of spurious out-of-band image signals in the frequency range of 4,6 kHz to 8 kHz measured selectively at the ERP shall be lower than the in-band acoustic level produced by a digital signal at 1 kHz set at the level specified in the following table.

**Table 8: Discrimination levels - receiving**

Boundaries of signal frequencies	Equivalent i/p level of 1 kHz
4,6 kHz	- 35 dBm0
8 kHz	- 45 dBm0

The limits at intermediate frequencies lie on a straight line drawn between the given values on a log(frequency)-linear(dB) scale.

**7.21.2 Method of measurement**

A digital signal generator, or an analogue signal generator followed by an ideal codec, shall be connected to point B of the ReFP as shown in figure 5 or to the S-reference point of a FP, and shall be set to provide a signal level of -10 dBm0 at the uniform PCM reference point D.

For input signals at the frequencies 500 Hz, 1 000 Hz, 2 000 Hz, and 3 150 Hz, the level of the corresponding image signals at frequencies up to 8 kHz shall be measured at the ear reference point.

**7.22 Sending noise**

**7.22.1 Requirement**

The noise produced by the apparatus in the sending direction shall not exceed - 64 dBm0.

**7.22.2 Method of measurement**

The PP shall be mounted at the LRGP and the earpiece sealed to the knife-edge of the artificial ear in an acoustically quiet environment (ambient noise less than -64 dBPa(A)).

A digital measuring instrument, or an ideal codec followed by an analogue level measuring set, shall be connected to point A of the ReFP as shown in figure 5, or to the S-reference point of a FP.

The noise level at the PCM interface point A shall be measured using psophometric weighting as described in CCITT Recommendations G.223 [13], table 4.

## **7.23 Sending noise (narrow band)**

### **7.23.1 Requirement**

The narrow-band noise (due to TDMA) produced by the apparatus in the sending direction, and contained within any 10 Hz bandwidth between the frequency limits 300 to 3 400 Hz, shall not exceed - 73 dBm0.

### **7.23.2 Method of measurement**

The PP shall be mounted at the LRGP and the earpiece sealed to the knife-edge of the artificial ear in the Low Noise Room.

An ideal codec followed by a selective measuring set or spectrum analyser with an effective bandwidth of 10 Hz shall be connected to point A of the ReFP as shown in figure 5, or to the S-reference point of a FP.

The rms voltage of the 10 Hz band limited signal shall be measured within the frequency range 305 Hz to 3 395 Hz.

## **7.24 Receiving noise**

### **7.24.1 Requirement**

If no user-controlled receiving volume control is provided, or if it is provided, at the setting where the RLR<sub>H</sub> is equal to the nominal value, the noise produced by the apparatus and measured at the ERP shall not exceed - 54 dBPa (A).

### **7.24.2 Method of measurement**

A digital signal generator, or an analogue signal generator followed by an ideal codec, shall be connected to point B of the ReFP as shown in figure 5, or to the S-reference point of a FP, and shall be set to provide a signal corresponding to decoder value number 1 at the uniform PCM reference point D.

With an ambient noise level not exceeding -64 dBPa(A), the noise level in the artificial ear shall be measured.

## **7.25 Sampling frequency level (receiving)**

### **7.25.1 Requirement**

The level of the 8 kHz measured selectively at the ERP shall be less than - 70 dBPa.

### **7.25.2 Method of measurement**

A digital signal generator, or an analogue signal generator followed by an ideal codec, shall be connected to point B of the ReFP as shown in figure 5, or to the S-reference point of a FP, and shall be set to provide a signal corresponding to decoder value number 1 at the uniform PCM reference point D.

With an ambient noise level not exceeding -64 dBPa(A), the level of any 8 kHz signal in the artificial ear shall be measured.

## **7.26 Acoustic shock**

The essential requirements and test for acoustic shock are not within the scope of this TBR. They are covered by the Low Voltage Directive (LVD) 73/23/EEC [30].

For information see DECT requirements in subclause 7.8 of ETS 300 175-8 [8].

**7.27 DECT network delay**

This test shall only apply when testing a FP and a PP as a pair.

**7.27.1 Requirement**

The sum of the delays from the MRP to the electrical line interface and from the electrical line interface to the ERP (round-trip delay) shall not exceed 28,5 ms, for a digital line interface. If an analogue line interface is provided, the delay shall not exceed 29 ms including the A/D and D/A converters at the interface to the external network.

**7.27.2 Method of measurement**

The PP shall be mounted in the LRGP. The earpiece shall be sealed to the knife-edge of the artificial ear. The delay in send and receive directions shall be measured separately from MRP to the electrical interface ( $D_S$ ) and from the electrical interface to ERP ( $D_R$ ). The Acoustic Reference Level (ARL) shall be applied at the MRP. The level of the input signal at the electrical interface shall be adjusted to give -10 dBm0 at the S-reference point.

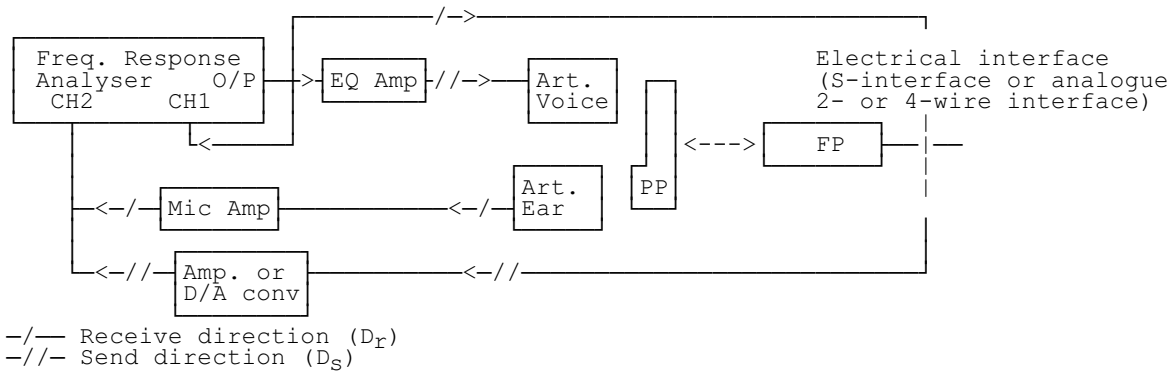

**Figure 7: DECT network delay test configuration**

For each of the nominal frequencies ( $f_0$ ) given in table 9 in turn, the delay at each value of  $f_0$  shall be derived from the measurements at the corresponding values of  $f_1$  and  $f_2$ .

**Table 9: Frequencies for delay measurement**

$f_0$ (Hz)	$f_1$ (Hz)	$f_2$ (Hz)
500	495,0	505,0
630	625,0	635,0
800	795,0	805,0
1 000	995,0	1 005,0
1 250	1 245,0	1 255,0
1 600	1 595,0	1 605,0
2 000	1 995,0	2 005,0
2 500	2 495,0	2 505,0

For each value of  $f_0$ , the delay shall be evaluated as follows:

- 1) output the frequency  $f_1$  from the frequency response analyser;
- 2) measure the phase shift in degrees between CH1 and CH2 ( $P_1$ );

- 3) output the frequency  $f_2$  from the frequency response analyser;
- 4) measure the phase shift in degrees between CH1 and CH2 ( $P_2$ );
- 5) compute the delay in milliseconds using the formula:

$$D = [-1000 \times (P_1 - P_2)] / [360 \times (f_1 - f_2)]$$

The measured phases  $P_2$  and  $P_1$  shall be used as original values. It is possible to have negative values at individual frequencies. Care must be taken that this real effect is not confused with measurement effects caused by passing  $360^\circ$ .

The delay introduced by the artificial mouth shall be measured by mounting the artificial ear microphone at the MRP. The delay of all additional test equipment  $D_e$  shall be determined using the procedures described above.

The delay of the item under test shall be deduced from the formula:

$$D = D_s + D_r - D_e$$

- 6) The network delay (PP and FP combined) shall be the mean value of the 8 measured delay values of  $D$ .

## 7.28 PP delay

This test shall only apply when testing a separate PP.

### 7.28.1 Requirement

The sum of the delays from the MRP to the air interface and from the air interface to the ERP (round-trip delay) shall not exceed 14,5 ms.

### 7.28.2 Method of measurement

A ReFP with a known 2-way delay  $D_{ReFP}$  between the air interface and the digital line interface shall be used. The PP shall be mounted at LRGP. The earpiece shall be sealed to the knife-edge of the artificial ear. The delay in send and receive directions shall be measured separately from MRP to the digital interface ( $D_s$ ) and from the digital interface to ERP ( $D_r$ ). The ARL shall be applied at the MRP. The level of the input signal at the electrical interface shall be adjusted to give -10 dBm0 at the S-reference point.

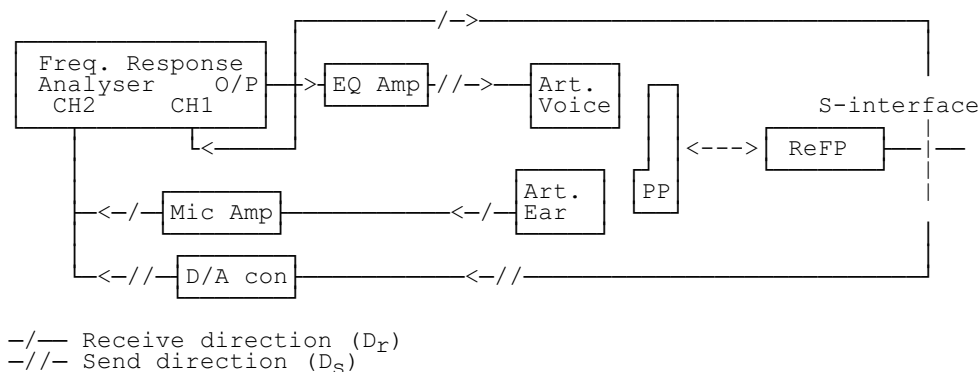

Figure 8: PP delay test configuration

For each of the nominal frequencies ( $f_0$ ) given in table 9 in turn, the delay at each value of  $f_0$  shall be derived from the measurements at the corresponding values of  $f_1$  and  $f_2$ .

For each value of  $f_0$ , the delay shall be evaluated as follows:

- 1) output the frequency  $f_1$  from the frequency response analyser;

- 2) measure the phase shift in degrees between CH1 and CH2 (P1);
- 3) output the frequency f2 from the frequency response analyser;
- 4) measure the phase shift in degrees between CH1 and CH2 (P2);
- 5) compute the delay in milliseconds using the formula:

$$D = [-1000 \times (P1 - P2)] / [360 \times (f1 - f2)]$$

The measured phases P2 and P1 shall be used as original values. It is possible to have negative values at individual frequencies. Care must be taken that this real effect is not confused with measurement effects caused by passing 360°.

The delay introduced by the artificial mouth shall be measured by mounting the artificial ear microphone at the MRP. The delay of all additional test equipment  $D_e$  shall be determined using the procedures described above.

The delay of the item under test shall be deduced from the formula :

$$D = D_s + D_r - D_e - D_{ReFP}$$

- 6) the PP delay shall be the mean value of the 8 measured delay values of D.

## 7.29 FP delay

This test shall apply when testing a separate FP.

### 7.29.1 Requirement

The sum of the delays from the electrical line interface to the air interface and from the air interface to the electrical line interface (round-trip delay) shall not exceed 15 ms for a digital line interface. If an analogue line interface is provided the delay shall no exceed 15,5 ms.

### 7.29.2 Method of measurement

A RePP with a known 2-way delay  $D_{RePP}$  between the air interface and the acoustical interface shall be used. The PP shall be mounted at LRGP. The earpiece shall be sealed to the knife-edge of the artificial ear. The delay in send and receive direction shall be measured separately from MRP to the electrical interface ( $D_S$ ) and from electrical to ERP ( $D_R$ ). The ARL shall be applied at the MRP. The level of the input signal at the electrical interface shall be adjusted to give -10 dBm0 at the S-reference point.

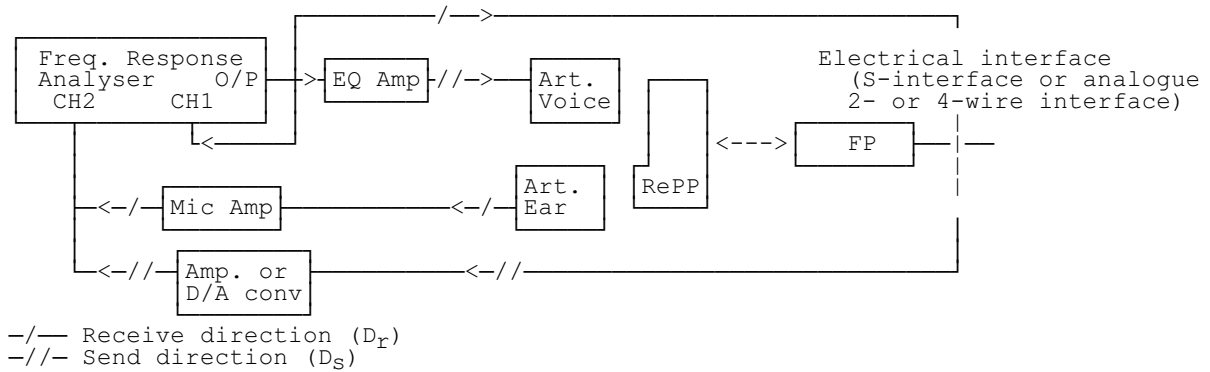

**Figure 9: FP delay test configuration**

For each of the nominal frequencies ( $f_0$ ) given in the table 9 in turn, the delay at each value of  $f_0$  shall be derived from the measurements at the corresponding values of  $f_1$  and  $f_2$ .

For each value of  $f_0$ , the delay shall be evaluated as follows:

- 1) output the frequency  $f_1$  from the frequency response analyser;
- 2) measure the phase shift in degrees between CH1 and CH2 ( $P_1$ );
- 3) output the frequency  $f_2$  from the frequency response analyser;
- 4) measure the phase shift in degrees between CH1 and CH2 ( $P_2$ );
- 5) compute the delay in milliseconds using the formula:

$$D = [-1000 \times (P_1 - P_2)] / [360 \times (f_1 - f_2)]$$

The measured phases  $P_2$  and  $P_1$  shall be used as original values. It is possible to have negative values at individual frequencies. Care must be taken that this real effect is not confused with measurement effects caused by passing  $360^\circ$ .

The delay introduced by the artificial mouth shall be measured by mounting the artificial ear microphone at the MRP. The delay of all additional test equipment  $D_e$  shall be determined using the procedures described above.

The delay of the item under test shall be deduced from the formula :

$$D = D_S + D_R - D_e - D_{RePP}$$

- 6) The network delay shall be the mean value of the 8 measured delay values of  $D$ .

### 7.30 Echo control at the network side

#### 7.30.1 Requirement

The network echo shall be controlled by inserting into the receiving speech path of the FP an echo loss meeting the requirements as defined in the following table.

**Table 10: Network echo control mask**

Echo path (2-way)			
Req. 1 -	0 to 4 ms	TELR	$\geq 24$ dB
Req. 2 -	0 to 60 ms	Extra echo loss	$\geq 9$ dB

Requirement 1 applies only to FP with an analogue 2-wire line interface. Requirement 2 applies for both 2 and 4-wire line interfaces. If the echo control device in the FP contains a soft suppressor, it is recommended not to suppress more than 12 dB.

The 24 dB TELR requirement corresponds to 14 dB weighted LE, at the uniform PCM reference point of the FP. This requirement shall be met for the whole range of 2-wire cable equivalents and termination impedances specified by the national authority.

Depending on routing information and on type of service, it may be possible to connect and disable each of the echo control functions which perform the respective requirements 1 and 2.

#### 7.30.2 Method of measurement

It shall be possible to disable every echo control function implemented in the FP. During this test, the echo control device specified in prETS 300 175-8 [8], subclause 7.4.1.2b shall be disabled. The applicant shall declare to the test laboratory, how this shall be done.

##### 7.30.2.1 4-wire interface

A signal source shall be connected to the input of the S-interface of the RePP, and a level measuring set shall be connected to the output of the S-interface of the RePP.

The signal source shall be a digital signal derived from the CCITT Recommendation P.50 "Artificial Voices" [21] assuming a flat sending frequency response of the RePP. Five measurements shall be made at each of the input signal levels,  $L_{in}$  of - 10, - 20 and - 25 dBmO at the S-interface of the RePP. The mean dB value at each signal level shall be taken.

The S-interface of the FP shall be connected to a delay circuit. The signal shall be looped back to produce a wanted LE,  $LE = 15$  dB. See figure 10. For an analogue 4-wire interface, the loss measured at the S-interface of the RePP shall be 15 dB, when the echo control of the FP is disabled.

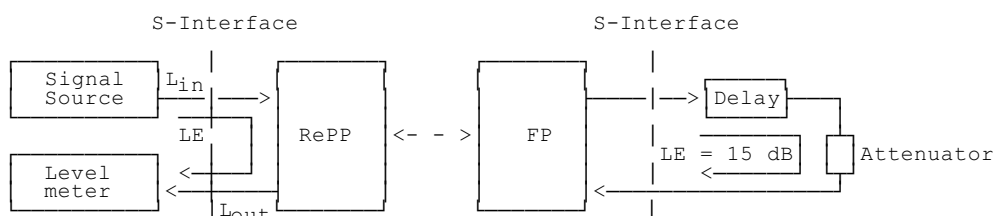

**Figure 10: FP with 4-wire interface**

For each signal level, the input signal shall be applied for more than 2 seconds before  $L_{out}$  is measured.

For any combination of input levels,  $L_{in}$  and the delays 0 ms, 20 ms and 60 ms, the LE at the S-interface of the RePP shall be at least  $15 + 9$  dB = 24 dB. The LE shall be calculated according to CCITT Recommendation G. 122 [11].



If no RePP is available for testing, a suitable accessible PCM reference point in the FP may be used if such a point is not accessible in the PP. If such a point is not accessible in the PP or FP, the PP shall be placed in the LRGP with its sidetone path disconnected and the artificial voice shall be applied at the MRP. The input signal levels shall be adjusted to correspond to the levels specified for the S-interface of the RePP corresponding with  $SLR_H = 7$  dB. Talker's Echo Loudness Rating (TELR), shall be measured instead of the LE of the RePP. The formula  $TELR = LE(\text{RePP}) + 10$  dB shall be used.

### 7.30.2.2 Analogue 2-wire interface

The local DECT system shall meet the SLR and RLR requirements of the national authority. The FP gain controls of the input and output signals shall have been adjusted to meet these requirements corresponding with a PP that has  $SLR_H = 7$  dB and  $RLR_H = 3$  dB referred to a reference PCM point in the PP.

#### 7.30.2.2.1 Requirement 1:

The measurement shall be made with the time dispersion inherent in the 2-4 wire hybrid circuit and in the terminating cable equivalent. No extra delay shall be introduced in the cable equivalent circuitry. The applicant shall declare that the control range of the echo control device is not less than 4 ms.

A signal source shall be connected to this input of the S-interface of the RePP and a level measuring set shall be connected to the output of the S-interface of the RePP.

The signal source shall be a digital signal derived from the CCITT Recommendation P.50 "Artificial Voices" [21] assuming a flat sending frequency response of the RePP. Five measurements shall be made at each of the input signal levels,  $L_{in}$  of - 10, - 20 and - 25 dBmO at the S-interface of the RePP. The mean dB value at each signal level shall be taken.

The 2-wire interface of the FP shall be terminated by an impedance Z. See figure 11.

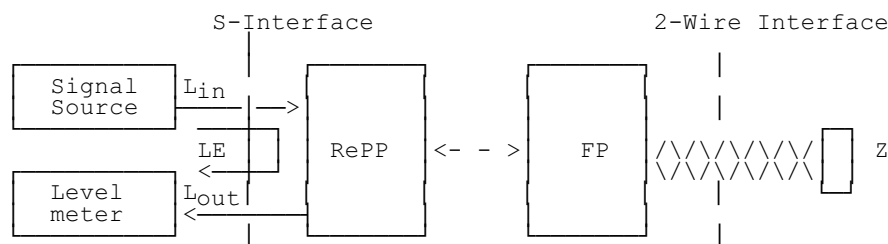

Figure 11: FP with analogue 2-wire interface

The input signal  $L_{in}$ , shall for each level be applied for at least 2 seconds before  $L_{out}$  is measured. The extra echo loss of requirement 2 (see table 10) shall be set to the lowest value that can be selected according to routing information.

For any combination of input signal levels,  $L_{in}$  and values of Z given by the national authority, the LE shall be at least 14 dB ( $LE = TELR - SLR_H - RLR_H - 24 - 10$  dB). The LE shall be calculated according to CCITT Recommendation G. 122 [11].

If no RePP is available for testing, a suitable accessible PCM reference point in the FP may be used, if such a point is not accessible in the PP. If such a point is not accessible in the PP or FP, the PP shall be placed in the LRGP with its sidetone disconnected and white noise shall be applied at the MRP. The input signal levels shall be adjusted to correspond to the levels specified for the S-interface of the RePP assuming that  $SLR_H = 7$  dB. TELR shall be measured instead of the LE of the RePP. The formula  $TELR = LE(\text{RePP}) + 10$  dB shall be used.

NOTE: Proper values of Z are given by cable equivalents and termination impedances specified for test of the sidetone requirement for analogue telephones. The values of Z, SLR and RLR for a country may differ for connection to a public extension and a PABX extension. Subject to future standardisation. One set of values for Z could be used to verify the echo control function.

7.30.2.2.2 Requirement 2:

If the option is available to reduce or disable the extra echo loss for requirement 2 (see table 10) depending upon routing information the applicant shall declare to the test laboratory how this is done.

A signal source shall be connected to this input of the S-interface of the RePP and a level measuring set shall be connected to the output of the S-interface of the RePP.

The signal source shall be a digital signal derived from the CCITT Recommendation P.50 "Artificial Voices" [21] assuming a flat sending frequency response of the RePP. Five measurements shall be made at each of the input signal levels,  $L_{in}$  of - 10, - 20 and - 25 dBmO at the S-interface of the RePP. The mean dB value at each signal level shall be taken.

The 2-wire interface of the FP shall be terminated by an impedance Z. See figure 11.

The 2-wire interface of the FP shall be connected to a matched 2-wire to 4-wire hybrid circuit providing the nominal load Z at the 2-wire interface. See figure 12. The 4-wire side shall be connected to a circuit providing 60 ms delay. The signal shall be looped back to provide an echo. The attenuator of the termination shall be adjusted to give an LE of 15 dB at the RePP when the echo control functions of the FP are disabled.

The echo control functions for requirements 1 and 2 are reactivated. The input signal,  $L_{in}$ , shall for each level be applied for at least 2 seconds before  $L_{out}$  is measured. The output level  $L_{out}$ , shall be measured during a time window of 20-60 ms from the switch-off time of the input  $L_{in}$ .  $L_{in}$  shall be below - 50 dBmO, 10 ms after the switch-off time.

The LE, shall be at least 24 dB for any of the specified levels of  $L_{in}$ . The LE shall be calculated according to CCITT Recommendation G. 122 [11].

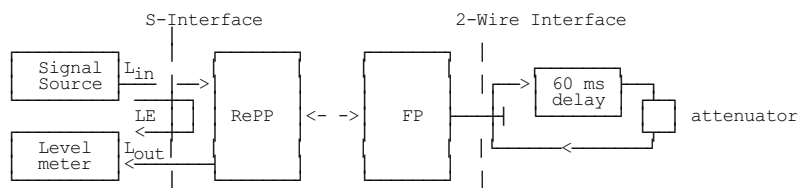

Figure 12: FP with analogue 2-wire interface

If a RePP is not available for testing, a suitable accessible PCM reference point in the FP may be used if such a point is not accessible in the PP. If such a point is not accessible in the PP or FP, the PP shall be placed in the LRGP with its sidetone disconnected and white noise shall be applied at the MRP. The input signal levels shall be adjusted to correspond to the levels specified for the S-interface of the RePP corresponding with  $SLR_H = 7$  dB. TELR, shall be measured instead of the LE, of the RePP. The formula  $TELR = LE (RePP) + 10$  dB shall be used.

**7.31 Variation of gain with input level- sending**

**7.31.1 Requirement**

The gain variation relative to the gain for ARL shall remain within the limits given in the following table.

**Table 11: Variation of gain with input level, sending**

Sending dB relative to ARL	Upper limit (dB)	Lower limit (dB)
+ 13	1	- 11
	1	*
+ 4	1	- 2
- 30	1	- 2
- 30	1	- infinite
- 40	1	
	*	
- 45	6	

NOTE \*: The limits for intermediate levels can be found by drawing straight lines between the breaking points in the Table on a linear (dB signal level) - linear (dB gain) scale.

**7.31.2 Method of measurement**

The handset shall be mounted at LRGP and the earpiece shall be sealed to the knife-edge of the artificial ear.

A sine-wave signal with a frequency in the range 1004 Hz to 1025 Hz shall be applied at the MRP. The level of this signal shall be adjusted until the output of the terminal is - 10 dBm0. The level of the signal at the MRP is then the ARL.

The test signal shall be applied at the following levels:

- 45, - 40, - 35, - 30, - 25, - 20, - 15, - 10, - 5, 0, 5, 10, 13 dB relative to ARL.

The variation of gain relative to the gain for ARL shall be measured.

NOTE: Selective measurement may be used to avoid the effects of ambient noise.

**7.32 Variation of gain with input level- receiving****7.32.1 Requirement**

The gain variation relative to the gain at an input level of -10 dBm0, shall be within the limits given in the following table.

**Table 12: Variation of gain with input level, receiving**

Receiving level at the digital interface	Upper limit (dB)	Lower limit (dB)
+ 3 dBm0	1	- 11
	1	*
- 6 dBm0	1	- 2
- 50 dBm0	1	- 2
- 50 dBm0	1	- infinite

NOTE \*: The limits for intermediate levels can be found by drawing straight lines between the breaking points in the Table on a linear (dB signal level) - linear (dB gain) scale.

**7.32.2 Method of measurement**

The handset shall be mounted at LRGP and the earpiece shall be sealed to the knife-edge of the artificial ear.

A digitally simulated sine-wave signal with a frequency in the range 1004 Hz to 1025 Hz shall be applied at the digital interface at the following levels:

- 50, - 45, - 40, - 35, - 30, - 25, - 20, - 15, - 10, - 5, 0, 3 dBm0.

The variation of gain relative to the gain at an input level of - 10 dBm0 shall be measured in the artificial ear.

NOTE: Selective measurement may be used to avoid the effects of ambient noise.

**8 Loudspeaking and handsfree telephony**

Loudspeaking and handsfree telephony may each optionally be provided. Speech performance requirements for these additional facilities are outside the scope of this TBR.

If loudspeaking and/or handsfree telephony is implemented in telephony 3,1 kHz terminals, the terminals in handset mode shall fulfil the speech transmission requirements of Clause 7. The switch from handset mode to loudspeaking or handsfree mode and vice versa shall be possible at any time without loss of communication.

**Annex A (informative): Essential requirement justification**

The table below provides a summary of the essential requirement Articles of the Terminal Directive [28] justifying the tests in this TBR.

**Table 13:**

Subclause Number of Test	Applicable to + Article		
	PP	FP	System
7.6	█ 4g	█ 4g	█ 4g
7.7	█ 4g		█ 4g
7.8	█ 4g		█ 4g
7.9	█ 4g		█ 4g
7.10	█ 4g		█ 4g
7.11	█ 4g		█ 4g
7.12	█ 4g		█ 4g
7.13	█ 4g		█ 4g
7.14		█ 4g	█ 4g
7.15	█ 4g		█ 4g
7.16	█ 4g		█ 4g
7.17	█ 4g		█ 4g
7.18	█ 4g		█ 4g
7.19	█ 4g		█ 4g
7.20	█ 4g		█ 4g
7.21	█ 4g		█ 4g
7.22	█ 4g		█ 4g
7.23	█ 4g		█ 4g
7.24	█ 4g		█ 4g
7.25	█ 4g		█ 4g
7.26			█ 4g
7.27	█ 4g		█ 4g
7.28	█ 4g		█ 4g
7.29		█ 4g	█ 4g
7.30		█ 4g	█ 4g
7.31	█ 4g		█ 4g
7.32	█ 4g		█ 4g

## History

Document history	
December 1993	First Edition
January 1996	Converted into Adobe Acrobat Portable Document Format (PDF)