



TECHNICAL
BASIS for
REGULATION

DRAFT
pr **TBR 007**
April 1996
Second Edition

Source: ETSI TC-RES

Reference: RTBR/RES-04008

ICS: 33.060.20 33.060.50

Key words: ERMES, paging, radio, type approval

**Radio Equipment and Systems (RES);
European Radio MESSage System (ERMES);
Receiver requirements**

ETSI

European Telecommunications Standards Institute

ETSI Secretariat

Postal address: F-06921 Sophia Antipolis CEDEX - FRANCE

Office address: 650 Route des Lucioles - Sophia Antipolis - Valbonne - FRANCE

X.400: c=fr, a=atlas, p=etsi, s=secretariat - **Internet:** secretariat@etsi.fr

Tel.: +33 92 94 42 00 - Fax: +33 93 65 47 16

*

Copyright Notification: No part may be reproduced except as authorized by written permission. The copyright and the foregoing restriction extend to reproduction in all media.

© European Telecommunications Standards Institute 1996. All rights reserved.

Contents

Foreword	7
1 Scope	9
2 Normative references	9
3 Definitions and abbreviations	10
3.1 Introduction	10
3.2 Vocabulary	10
3.2.1 Administrative terms	10
3.2.2 Identity related terms	10
3.2.3 Services, facilities and receiver features	10
3.2.4 Network related terms	10
3.2.5 Area concepts	11
3.2.6 Terms related to the radio subsystem	11
3.3 Abbreviations and acronyms	11
4 General	11
4.1 Introduction	11
4.2 Choice of model for approval testing	12
4.3 Description of equipment	12
4.3.1 Manufacturer's declaration	12
4.4 Mechanical and electrical design	13
4.5 Categories of receivers	13
4.6 Requirements and justifications	13
4.6.1 Average usable sensitivity (normal)	13
4.6.2 Degradation in required sensitivity under channel switching	13
4.6.3 Degradation in required sensitivity in extremes and offset	13
4.6.4 Co-channel rejection (normal)	14
4.6.5 Adjacent channel selectivity (normal)	14
4.6.6 Adjacent channel selectivity (extreme)	14
4.6.7 Spurious response immunity	14
4.6.8 Intermodulation immunity	15
4.6.9 Blocking immunity or desensitisation	15
4.6.10 Usable input range	15
4.6.11 The maximum degradation in required sensitivity for combined multi-path and quasi-synchronous transmissions	15
4.6.12 Spurious emissions	16
4.6.13 Last message in batch	16
4.6.14 Message continued in next batch	16
4.6.15 Message in last available batch	17
4.6.16 Tenure of message	17
4.6.17 Two messages in the same batch	17
4.6.18 Message continued in the next sub-sequence	17
4.6.19 Message reception on all ERMES channels	17
4.6.20 Recognition of zone code	17
4.6.21 Two messages in the same batch	18
4.6.22 Message in overlap areas (BAI = 1)	18
4.6.23 Message in overlap areas (BAI = 0)	18
4.6.24 Receiver paging categories	18
4.6.24.1 Tone-only functions	18
4.6.24.2 Numeric category functions	18
4.6.24.3 Alphanumeric category functions	18
4.6.25 Termination of numeric messages due to reception errors	19
4.6.26 Termination of alphanumeric messages due to reception errors	19
4.6.27 Group call	19
4.6.28 Tenure of group messages	19

4.6.29	Recognition of FSI	19
4.6.30	Multioperator environment	20
4.6.31	RSVD bits	20
4.6.32	Additional features	20
4.7	Interpretation of measurement results	20
5	General test requirements	20
5.1	Test philosophy	20
5.2	Receiver to be submitted for conformance testing.....	20
5.3	Normal test conditions.....	21
5.4	Extreme test conditions.....	21
5.5	Test fixture	21
5.6	Test paging signal	21
5.6.1	Successful tone-only call	21
5.6.2	Successful numeric message.....	22
5.6.3	Successful alphanumeric message.....	22
5.7	Declared category	22
5.7.1	General	22
5.7.2	Test time saving procedure	22
6	TBR requirements table.....	23
7	Tests for radio parameter conformance	23
7.1	Conformance requirements	23
7.2	Method of measurement	24
8	Tests for radio interface conformance.....	25
8.1	Last message in batch	26
8.2	Message continued in next batch.....	26
8.3	Message in last available batch	26
8.4	Tenure of message	27
8.5	Two messages in same batch	27
8.6	Message continued in the next sub-sequence.....	27
8.7	Message reception on all ERMES channels	28
8.8	Recognition of zone code.....	28
8.9	Two messages in the same batch	28
8.10	Message reception in overlap regions (BAI = 1)	28
8.11	Message reception in overlap regions (BAI = 0)	29
8.12	Messages.....	29
8.12.1	Tone message (alert signal indicator bits "000")	29
8.12.2	Maximum length numeric message.....	29
8.12.3	Maximum length alphanumeric message	30
8.13	Termination of numeric messages due to reception errors	30
8.14	Termination of alphanumeric messages	30
8.15	Group call.....	30
8.16	Tenure of group message.....	31
8.17	Recognition of FSI.....	31
8.18	Multioperator environment.....	32
Annex A (normative):	Measurement procedures.....	33
A.1	Average measured usable sensitivity expressed as field strength under normal conditions.....	33
A.1.1	Definition	33
A.1.2	Method of measurement	33
A.2	Radiated spurious components	34
A.2.1	Definition	34
A.2.2	Method of measurement	34
A.3	Co-channel rejection.....	35
A.3.1	Definition	35
A.3.2	Method of measurement	35

A.4	Adjacent channel selectivity	36
A.4.1	Definition	36
A.4.2	Method of measurement.....	36
A.5	Spurious response immunity	37
A.5.1	Definition	37
A.5.2	Method of measurement.....	37
A.6	Intermodulation immunity	38
A.6.1	Definition	38
A.6.2	Method of measurement.....	38
A.7	Blocking immunity	39
A.7.1	Definition	39
A.7.2	Method of measurement.....	39
A.8	Combined multi-path and quasi-synchronous transmissions.....	40
A.8.1	Definition	40
A.8.2	Method of measurement.....	40
Annex B (normative):	Ancillary test data	41
B.1	Simulated man	41
B.2	Definition of un-wanted test signal	41
B.3	Definition of reference figure	41
B.4	Sensitivity measurement test sites.....	42
B.4.1	Description of test sites for receiver sensitivity measurements	42
B.4.2	Description of an open air test site	42
B.4.2.1	Receiver sensitivity measurement test site characteristics	42
B.4.2.2	Receiver sensitivity measurement test site	42
B.4.2.3	Position of the equipment under test.....	43
B.4.2.4	Transmitting antenna.....	43
B.4.2.5	Calibration	43
B.4.2.6	Substitution antenna.....	44
B.4.2.7	Selective measuring device.....	44
B.4.3	Description of an anechoic chamber	45
B.5	Definition of test sites suitable for spurious emissions measurements.....	45
B.5.1	An anechoic chamber	45
B.5.1.1	General.....	45
B.5.1.2	Description	45
B.5.1.3	Influence of parasitic reflections	45
B.5.1.4	Calibration and mode of use	46
B.5.2	Open air test site suitable for emission tests	47
B.5.2.1	Test site characteristics for radiated emissions testing.....	48
B.5.2.2	Radiation emissions test site.....	48
B.5.2.3	Position of the equipment under test.....	49
B.5.2.4	Measuring antenna support.....	49
B.5.2.5	Measuring antenna.....	49
B.5.2.6	Substitution antenna.....	49
B.5.2.7	Radio-frequency signal generator	50
B.5.2.8	Selective measuring device.....	50
B.6	Description of test fixture.....	50
B.7	Measurement uncertainty.....	50
B.8	Maximum degradation in required sensitivity	51
B.9	Differential factors	51

B.9.1	General.....	51
B.9.2	Definition of numeric differential factor.....	51
B.9.3	Definition of alphanumeric differential factor	52
B.10	Calculations of spurious responses frequencies	53
B.10.1	Introduction to the method	53
Annex C (normative):	Character sets in the ERMES system	54
C.1	Characters for numeric paging	54
C.2	Characters for alphanumeric paging	54
History	56

Foreword

This draft second edition Technical Basis for Regulation (TBR) has been produced by the Radio Equipment and Systems (RES) Technical Committee of the European Telecommunications Standards Institute (ETSI), and is now submitted for Public Enquiry.

This TBR covers the requirements for terminal (mobile) equipment for use within the European Radio Message System (ERMES).

This TBR contains the procedures and requirements for the approval testing of ERMES terminal (mobile) equipment which are mainly intended to be body worn.

The ERMES equipment to be approved is not intended to be physically attached to the public network.

This TBR is based on ETS 300 133-4 [2] and ETS 300 133-5 [3].

This TBR also includes a vocabulary of terms and a list of abbreviations and acronyms.

Annexes A, B and C are normative and therefore integral parts of this TBR.

ETSI Interim Intellectual Property Rights (IPR) Policy

The attention of ETSI has been drawn to the IPRs listed below which are, or may become, Essential to this ETS. The IPR owner has undertaken to grant irrevocable licences on fair, reasonable and non-discriminatory terms and conditions under these IPRs pursuant to the ETSI Interim IPR Policy. Further details pertaining to these IPRs can be obtained directly from the IPR owner.

The information presently submitted is accurate to the best of ETSI's knowledge. Pursuant to the ETSI Interim IPR Policy, no investigation, including IPR searches, has been carried out by ETSI. No guarantee can thus be given as to the existence of other IPRs, which are, or may become, Essential to this ETS.

IPRs:

EP Patent No. 0090851:	Decoder for Transmitted Message Activation Codes;
EP App. No. 89909668,9:	Multiple Frequency Message System;
EP App. No. 89913131,2:	Power Conservation Method and Apparatus for a Portion of Information Signal;
EP App. No. 92901376,1:	Multiple Format Signalling Protocol for a Selective Call Receiver;
EP App. No. 90915018,7:	Nationwide Paging with Local Modes of Operation;
EP App. No. 91904526,0:	Multiple Frequency Scanning.

IPR owner:

MOTOROLA Ltd, 110 Bath Road, Slough, GB-BERKSHIRE SL1 3SZ

Blank page

1 Scope

This TBR specifies the technical characteristics to be provided by European Radio Message System (ERMES) terminal equipment, which are mainly intended to be body worn and are capable of the reception and decoding of signals transmitted according to the ERMES standard, as described in ETS 300 133-4 [2].

The objective of this TBR is to ensure that ERMES terminal equipment meets the essential requirements as laid down in terms of the Directive 91/263/EEC [6], Articles 4d to 4g.

There are no specific EMC requirements included in this TBR for Article 4c of Directive 91/263/EEC [6]. The general EMC requirements for ERMES are included in ETS 300 340 [10].

2 Normative references

This TBR incorporates by dated and undated reference, provisions from other publications. These normative references are cited at the appropriate places in the text and the publications are listed hereafter. For dated references, subsequent amendments to or revisions of any of these publications apply to this TBR only when incorporated in it by amendment or revision. For undated references the latest edition of the publication referred to applies.

- [1] prETS 300 133-2 (1996): "Radio Equipment and Systems (RES) - European Radio Message System (ERMES) Part 2: Service aspects".
- [2] prETS 300 133-4 (1996): "Radio Equipment and Systems (RES) - European Radio Message System (ERMES) Part 4: Air interface specification".
- [3] prETS 300 133-5 (1996): "Radio Equipment and Systems (RES) - European Radio Message System (ERMES) Part 5: Receiver conformance specification".
- [4] ISO Standard 1073 parts 1 & 2: "Alphanumeric character sets for optical recognition".
- [5] CTR Scope (5/3/92): "European Radio Message System (ERMES) - Approval requirements for paging receivers" (NTRAC).
- [6] Official Journal of the European Communities Volume 34, 23 May 1991: "Council Directive 91/263 /EEC of 29 April 1991 on the approximation of the laws of the Member States concerning telecommunications terminal equipment, including the mutual recognition of their conformity".
- [7] Handbook on CTRs, Draft Issue 2 for presentation to TRAC on 16/17 February 1993.
- [8] prETS 300 133-6 (1996): "Radio Equipment and Systems (RES) - European Radio Message System (ERMES) Part 6: Base station conformance specification".
- [9] ETR 028: "Radio Equipment and Systems (RES) - Uncertainties in the measurement of mobile radio equipment characteristics".
- [10] ETS 300 340: "Radio Equipment and Systems (RES); Electro-Magnetic Compatibility (EMC) for European Radio Message System (ERMES) paging receivers".
- [11] ITU-T Recommendation E212. "Identification plan for land mobile stations", Annex A.

3 Definitions and abbreviations

3.1 Introduction

The terms, definitions and abbreviations used within this TBR are given in this clause. A definition or a reference to a definition given in this clause is valid for all clauses of this TBR.

An explanation of all the abbreviations and acronyms used in this TBR is given in alphabetical order in subclause 3.3.

The definitions are presented in six groups. Within each group the definitions are given in a conceptual order rather than alphabetical order.

3.2 Vocabulary

3.2.1 Administrative terms

user: A person or machine initiating an access to the operator network or receiving a message through the operator network. User includes mobile subscribers, fixed subscribers and non-registered customers.

network operator: The administration/company which is responsible for the technical and commercial operation of the operator network.

home operator: The network operator to which a specific user has subscribed.

3.2.2 Identity related terms

basic RIC: The prime identity of the paging receiver allocated by the network operator when service is initiated. It can not be changed without safeguards against unauthorised changes.

country code: Binary representation of the country number defined in reference [11]. The country code consists of 7 bits.

initial address: The 18 most significant bits of the local address.

operator identity: The number used by the system on the radio path to identify the home operator of a receiver. It has a total length of 13 bits and consists of three parts, the zone code, the country code and the operator code

operator code: The number used by the system to identify an operator within a country. It consists of 3 bits.

Radio Identity Code (RIC): The number used by the system on the radio path to identify the receiver(s) for which the paging signal is intended. RIC has a total length of 35 bits and consists of four parts: The zone code (3 bits) the country code (7 bits), the operator code (3 bits) and the local address (22 bits).

zone code: Binary representation of the zone number defined in reference [11]. The zone code consists of 3 bits.

3.2.3 Services, facilities and receiver features

group call: A call intended for two or more mobile subscribers.

3.2.4 Network related terms

ERMES system: The totality of the operator networks.

home network: The operator network with which a mobile subscriber has signed a subscription.

3.2.5 Area concepts

paging area: The area controlled by a Paging Area Controller (PAC). It is the minimum area to which a mobile subscriber is permitted to subscribe in order to receive his paging messages.

3.2.6 Terms related to the radio subsystem

alert signal: The signal generated by the receiver as an indication of a received paging signal.

alert signal indicator: The information bits contained in the I1 message header that determines which alert signal should be generated at the receiver. It is related to the address code input by the calling party.

batch number: The 4 bit number corresponding to a particular batch type. Batch type A corresponds to batch number 0000. Batch type P corresponds to batch number 1111.

batch type: The letter (A to P) which identifies one of the 16 batches within a sub-sequence.

code word: The standard information unit of 30 bits length (used on the air interface).

code block: The unit of nine interleaved code words used in the message partition of the air interface.

End Of Message (EOM) character: A specific character used to indicate the end of an alphanumeric message. It corresponds to DC1 as defined in ETS 300 133-2 [1], annex B, clause B.2.

paging signal: The signal sent on the radio path to a paging receiver.

3.3 Abbreviations and acronyms

For the purposes of this TBR, the following abbreviations apply:

BAI	Border Area Indicator
CTA	Common Temporary Address
CTAP	Common Temporary Address Pointer
EOM	End of Message
ERMES	European Radio Message System
EUT	Equipment Under Test
IA	Initial Address
LCD	Liquid Crystal Display
p.d.	potential difference
PAC	Paging Area Controller
RF	Radio Frequency
RIC	Radio Identity Code
rms	root mean square
RSVD	Reserved bits for future definition
SSI	Supplementary System Information
TBR-RT	Technical Basis for Regulation - Requirements Table

4 General

4.1 Introduction

This TBR is based on the CTR Scope statement [5] from NTRAC on CTR No. 7.

This TBR specifies the receiver conformance requirements and the considered relevance of the Articles from the directive 91/263/EEC [6] with regard to ERMES receivers. The CTR Scope statement suggests that this TBR should only consider Articles 4e, 4f, and 4g. Article 4a is dealt with under the Low Voltage Directive (73/23/EEC), while Articles 4b and 4d are considered not relevant for this TBR. In the TBR Requirements Table (TBR-RT) given in clause 6, the tests to be carried out on ERMES receivers are tabulated.

4.2 Choice of model for approval testing

The applicant shall provide one preliminary or production model of the equipment, as appropriate for approval testing.

If approval is given on the basis of tests on a preliminary model, then the corresponding production models shall be identical in all respects to the preliminary model tested.

4.3 Description of equipment

The applicant shall provide the following information to the test laboratory.

4.3.1 Manufacturer's declaration

A declaration by the manufacturers or applicant shall be supplied detailing the following parameters:

- a) the normal and extreme test voltages, see ETS 300 133-5 [3], subclauses 4.2 and 4.3;
- b) any combination of the control characters ESC, LF and CR and any other character which should not be used for test in subclause 4.6.24.3, see ETS 300 133-5 [3], subclause 7.3;
- c) a statement demonstrating that no combination of the RSVD bits affects the performance of the receiver with respect to this TBR, subclause 4.6.31;
- d) the method to simulate insufficient quality of reception (BER, code word error rate, erroneous system information) and the time constraints to be used in test 8.11, see ETS 300 133-5 [3] subclause 7.2.5;
- e) a statement demonstrating that any features in the receiver that are additional to the requirements of this TBR do not affect the performance of the receiver with respect to this TBR, see subclause 4.6.32;
- f) there will be a certain minimum time after a receiver is switched on before it is capable of receiving messages as described in the tests in clause 6. It is required that this time is stated, see ETS 300 133-5 [3] subclause 7.12.1;
- g) the category of receiver shall be declared (see subclause 4.5);
- h) the alerts associated with all the alert signal indicator bit sequences shall be declared. In addition the means whereby these alerts may be tested shall be explained. If any additional equipment is required to test these alerts, then this shall be supplied by the manufacturer, see ETS 300 133-5 [3] subclause 6.3.1;
- j) the message presentation technique shall be declared by the manufacturer. This is required to enable the test laboratory to test the message function;
- k) the receiver shall have a basic RIC. The manufacturer shall declare that this RIC is within the definition in ETS 300 133-4 [2], clause 3;
- l) the reference orientation that shall be close to the orientation in normal use;
- m) for the calculations of spurious response measurement the manufacturer shall state the frequency of the oscillator signal applied to the first mixer of the receiver, the intermediate frequencies of the receiver and the switching range;
- n) the time required by the receiver to achieve synchronisation before the radio performance criteria may be determined;
- o) the time during which the receiver remains on channel after loss of signal.

4.4 Mechanical and electrical design

Any control or adjustment which, if maladjusted, could affect the conformance of the product to this TBR shall not be readily accessible to the user.

4.5 Categories of receivers

There are four categories of receivers, according to the different paging services they are designed to provide. Table 1 describes each of the four categories.

Table 1: Categories of receivers

Category	Description
1	A receiver providing this function shall respond to at least one combination of the alert signal indicator bits. Responses to the remaining seven alert indicator bits shall (if implemented) be clearly distinguishable.
2	A receiver including this function shall provide for the reception of a 20 digit numeric message. The numeric character set is included in annex C. Receivers having this function shall also have the tone-only function.
3	A receiver including this function shall provide for the reception of a 400 character text message. The alphanumeric character set is included in annex C. Receivers having this function shall also have the numeric and the tone-only functions.
4	A receiver including this function shall provide for the reception of an arbitrary data message.

4.6 Requirements and justifications

4.6.1 Average usable sensitivity (normal)

The receiver under test shall meet the specifications as defined in subclause 7.1 a).

The receiver is required to meet the above specification in order to provide sufficient call success rate under static field conditions when the transmitted field strength is at the defined level. This level has been chosen as a suitable limit level when economic, technical and regulatory considerations are taken into account. It is therefore required that receivers shall meet the specification as defined in subclause 7.1 a) and measured as defined in subclause 7.2 a).

Reference:

ETS 300 133-5 [3], subclause 5.1 a).

4.6.2 Degradation in required sensitivity under channel switching

The receiver under test shall meet the specifications as defined in subclause 7.1 b).

One of the essential features of the ERMES system is that the paging messages are distributed in a multiple frequency environment. It is therefore required that the receivers maintain their sensitivity to paging messages while they are scanning through the frequencies used in the system as defined in subclause 7.1 b) and measured as defined in subclause 7.2 l).

Reference:

ETS 300 133-5 [3], subclause 5.1 c).

4.6.3 Degradation in required sensitivity in extremes and offset

The receiver under test shall meet the specifications as defined in subclause 7.1 c).

The operating temperature range for the receiver is - 10° C to + 55° C. This range should cover the range of temperatures normally experienced in Europe by a body worn product. The receiver under test is primarily intended to be portable and therefore its power is derived from a battery. During the life of this battery, its terminal voltage may change, and to ensure that the performance of the receiver is not

impaired unreasonably, this test includes measuring the sensitivity of the receiver at the extreme test voltage as specified by the manufacturer. In the transmitter system that may be used for an ERMES network, it is possible that the transmitted frequencies could be up to 200 Hz offset from the nominal frequencies (see ETS 300 133-6 [8], subclause 5.3). It is required that the receiver shall continue to receive paging messages at the extremes of the temperature and voltage range (as specified in subclause 5.4) and with a transmitter frequency offset of 200 Hz as defined in subclause 7.1 c) and measured as defined in subclause 7.2 c).

References:

ETS 300 133-5 [3], subclause 5.1 e).

ETS 300 133-6 [8], subclause 5.3.

4.6.4 Co-channel rejection (normal)

The receiver under test shall meet the specifications as defined in subclause 7.1 d).

In the transmitter system that may be used for an ERMES network, it is possible that the receiver shall receive signal from two transmitters on the same frequency, but with different data being transmitted. In order that paging messages can still be received under these conditions, it is required that the receiver shall meet the specification as defined in subclause 7.1 d) and measured as defined in subclause 7.2 e).

Reference:

ETS 300 133-5 [3], subclause 5.1 f).

4.6.5 Adjacent channel selectivity (normal)

The receiver under test shall meet the specifications as defined in subclause 7.1 e).

In the transmitter system that may be used for an ERMES network, it is possible that a receiver may suffer from radio interference from a signal being transmitted on a channel adjacent to the required channel. In order that paging messages can still be received under these conditions, it is required that the receiver shall meet the specification as defined in subclause 7.1 e) and measured as defined in subclause 7.2 f).

Reference:

ETS 300 133-5 [3], subclause 5.1 g).

4.6.6 Adjacent channel selectivity (extreme)

The receiver under test shall meet the specifications as defined in subclause 7.1 f).

In the transmitter system that may be used for an ERMES network, it is possible that a receiver may suffer from radio interference from a signal being transmitted on a channel adjacent to the required channel. It is also possible that the extreme temperature conditions as described in subclause 4.6.3 are also experienced at the same time. In order that paging messages can still be received under these conditions, it is required that the receiver shall meet the specification as defined in subclause 7.1 f) and measured as defined in subclause 7.2 f).

Reference:

ETS 300 133-5 [3], subclause 5.1 h).

4.6.7 Spurious response immunity

The receiver under test shall meet the specifications as defined in subclause 7.1 g).

In the normal radio environment it is possible that radio signals are presented to the receiver to which the receiver is not intended to respond. However, the receiver may respond to some of these signals. This test is concerned with the situation when these un-wanted interfering signals are at particular frequencies

at which the receiver may respond. These frequencies are calculated by considering the design of the receiver. In order that paging messages can still be received when these un-wanted signals are present and below the specified limit value, it is required that the receiver shall meet the specification as defined in subclause 7.1 g) and measured as defined in subclause 7.2 g).

Reference:

ETS 300 133-5 [3], subclause 5.1 j).

4.6.8 Intermodulation immunity

The receiver under test shall meet the specifications as defined in subclause 7.1 h).

In the normal radio environment it is possible that radio signals are presented to the receiver to which the receiver is not intended to respond. However, the receiver may respond to some of these un-wanted interfering signals. This test is concerned with the situation when there are 2 un-wanted interfering signals which are equidistant from the wanted signal and each other. The probability of this situation occurring increases as the radio spectrum becomes more crowded. In order that paging messages can still be received when these un-wanted signals are present and below the specified limit values, it is required that the receiver shall meet the specification as defined in subclause 7.1 h) and measured as defined in subclause 7.2 h).

Reference:

ETS 300 133-5 [3], subclause 5.1 k).

4.6.9 Blocking immunity or desensitisation

The receiver under test shall meet the specifications as defined in subclause 7.1 j).

In the normal radio environment it is possible that radio signals are presented to the receiver to which the receiver is not intended to respond. However, the receiver may respond to some of these un-wanted interfering signals. This test is concerned with the situation when there is an interfering signal which is not one of the cases tested in subclause 7.1 h). The probability of this situation occurring increases as the radio spectrum becomes more crowded. In order that paging messages can still be received when this un-wanted signal is present and below the specified limit value, it is required that the receiver shall meet the specification as defined in subclause 7.1 j) and measured as defined in subclause 7.2 j).

Reference:

ETS 300 133-5 [3], subclause 5.1 l).

4.6.10 Usable input range

The receiver under test shall meet the specifications as defined in subclause 7.1 k).

In the normal radio environment the wanted signal level has a very large amplitude range. The amplitude of the received signal can vary by at least 100 dB and the receiver is required to operate satisfactorily over this range. This test is concerned with the situation when there is a high signal amplitude, approximately 105 dB above the sensitivity limit defined in subclause 7.1 a). This test is designed to ensure that the receiver will still receive paging messages at this high signal level and it is required that the receiver shall meet the specification as defined in subclause 7.1 k) and measured as defined in subclause 7.2 d).

Reference:

ETS 300 133-5 [3], subclause 5.1 m).

4.6.11 The maximum degradation in required sensitivity for combined multi-path and quasi-synchronous transmissions

(See annex B, clause B.8).

The receiver under test shall meet the specifications as defined in subclause 7.1 l).

In the normal radio environment the received signal will not have come directly from the transmitter but will have been reflected off a variety of buildings, vehicles, hills and people. The receiver receives a signal made up of a combination of all these reflections as well the possibility of a direct signal from the transmitter. This combined signal suffers from rapid amplitude and phase variations. In addition, the receiver may be moving. The total effect of this on the received field strength at the receiver may be estimated by the use of a Rayleigh simulator. The effect of these amplitude variations is greater when the average amplitude is low. Since buildings are usually absorbers of radio signals, it is considered that the lowest field strengths are experienced inside buildings. Velocity inside buildings is usually quite low and the value of 3 km/h was considered to be reasonable.

When two or more transmitters are used to transmit identical data in a geographical area there is always the possibility that signals from both transmitters will be received by the receiver at similar amplitudes. When this occurs, there will always be a difference between the timing of the modulation coming from the two transmitters. This difference can come from the timing at the transmitters and also from the differential time taken for the signal to reach the receiver from the transmitters. The ERMES system has been specified so that there could be a difference of 50 μ s between the timing of the modulation at the receivers. It is required that the receiver shall meet the specification as defined in subclause 7.1 l) with the method of measurement as defined in subclause 7.2 k).

Reference:

ETS 300 133-5 [3], subclause 5.1 n).

4.6.12 Spurious emissions

The receiver under test shall meet the specifications as defined in subclause 7.1 m).

The receiver is designed to receive radio signals, but all electronic equipment, when in use, will generate radio signals, these can be over the whole frequency band and can, if sufficiently strong, cause interference to users of equipment. In order to ensure that harmful interference is not generated by these receivers, it is required that the receiver shall meet the specification as measured in subclause 7.2 b).

Reference:

ETS 300 133-5 [3], subclause 5.1 o).

4.6.13 Last message in batch

The receiver shall present without error a message which is located in the last possible position in the same batch as the initial address. It is required that the receiver shall present, without error, the message transmitted as described in subclause 8.1.

Reference:

ETS 300 133-5 [3], subclause 7.1.2.

4.6.14 Message continued in next batch

The receiver shall successfully present without error a message which commences in one batch and finishes in the next. It is required that the receiver shall present, without error, the message transmitted as described in subclause 8.2.

Reference:

ETS 300 133-5 [3], subclause 7.1.3.

4.6.15 Message in last available batch

The receiver shall be capable of presenting a message which appears in any batch before the next addressing opportunity on that channel. It is required that the receiver shall present, without error, the message transmitted as described in subclause 8.3.

Reference:

ETS 300 133-5 [3], subclause 7.1.4.

4.6.16 Tenure of message

The receiver shall be sent an Initial Address (IA) with the associated message delayed by 16 batches. The receiver shall not present the message. It is required that the receiver shall not present the message transmitted as described in subclause 8.4.

Reference:

ETS 300 133-5 [3], subclauses 7.1.5 and 7.1.7.

4.6.17 Two messages in the same batch

The receiver shall be capable of presenting two messages in the same transmission. It is required that the receiver shall present, without error, both the messages transmitted as described in subclause 8.5.

Reference:

ETS 300 133-5 [3], subclause 7.1.6.

4.6.18 Message continued in the next sub-sequence

The receiver shall successfully present a message which commences in one sub-sequence and finishes in the next. It is required that the receiver shall present, without error, both the messages transmitted as described in subclause 8.6.

Reference:

ETS 300 133-5 [3], subclause 7.1.7.

The purpose of the tests in subclauses 4.6.19 to 4.6.23 inclusive is to ensure that the receiver can present messages in areas away from the home network.

4.6.19 Message reception on all ERMES channels

Receivers shall be able to receive transmissions on all of the ERMES channels. It is required that the receiver shall present, without error, messages received on all these channels when the messages are transmitted as described in subclause 8.7.

Reference:

ETS 300 133-5 [3], subclause 7.2.1.

4.6.20 Recognition of zone code

When the zone code is not the same as the home zone code, the receiver shall not present messages transmitted to a home receiver. It is required that the receiver shall not present messages received when the messages are transmitted as described in subclause 8.8.

Reference:

ETS 300 133-5 [3], subclause 7.2.2.

4.6.21 Two messages in the same batch

The receiver shall successfully distinguish between a message for a home receiver and a message for an external receiver even if both messages have the same IA. It is required that the receiver shall only receive the message for the external receiver when the messages are transmitted as described in subclause 8.9.

Reference:

ETS 300 133-5 [3], subclause 7.2.3.

4.6.22 Message in overlap areas (BAI = 1)

When the BAI is set to one the receiver shall examine all channels for messages.

It is required that the receiver shall present, without error, the two messages transmitted on a home network channel and a non-home network channel when the messages are transmitted as described in subclause 8.10.

Reference:

ETS 300 133-5 [3], subclause 7.2.4.

4.6.23 Message in overlap areas (BAI = 0)

When a receiver is in its home network and the BAI = 0 it is expected that the receiver will usually examine this channel. However, when the signal quality is unsatisfactory, the receiver shall examine other channels for messages. It is required that the receiver shall present, without error, messages received on a non-home network channel when the messages are transmitted as described in subclause 8.11.

Reference:

ETS 300 133-5 [3], subclause 7.2.5.

4.6.24 Receiver paging categories

4.6.24.1 Tone-only functions

A receiver with a tone-only function shall respond to the sequence of alert signal indicator bits 000. It is required that when tone-only calls as described in subclause 8.12.1 are transmitted, a receiver with a tone-only function shall alert.

Reference:

ETS 300 133-5 [3], subclause 7.4.1.

4.6.24.2 Numeric category functions

A receiver with a numeric function shall be able to present a message with at least 20 numeric characters. It is required that a receiver with a numeric function shall present without error messages when the messages are transmitted as described in subclause 8.12.2.

Reference:

ETS 300 133-5 [3], subclause 7.3.

4.6.24.3 Alphanumeric category functions

A receiver with an alphanumeric function shall be able to present a message with at least 400 alphanumeric characters. It is required that a receiver with an alphanumeric function shall present without error messages when the messages are transmitted as described in subclause 8.12.3.

The receiver shall be examined to ensure the characters have been presented correctly. The control characters ESC, LF, and CR shall not cause any character to be displayed. If the control characters are used in conjunction with any other characters specified by the manufacturer, these combinations shall not be sent for this test.

Reference:

ETS 300 133-5 [3], subclause 7.3.

4.6.25 Termination of numeric messages due to reception errors

A receiver offering a numeric feature shall not present any character of the numeric message after having received a code word in error.

The receiver shall only present without error characters 1234, when the transmission as described in subclause 8.13 is received.

Reference:

ETS 300 133-5 [3], subclause 7.5.

4.6.26 Termination of alphanumeric messages due to reception errors

An alphanumeric category receiver shall not present any subsequent character after having received two consecutive code words in error. It is required that when two code words in the message constructed as described in subclause 8.14, only the characters in MESSAGE shall be presented.

Reference:

ETS 300 133-5 [3], subclause 7.6.

4.6.27 Group call

The receiver shall be capable of presenting a group message which appears in any batch before the next addressing opportunity on that channel. It is required that the message shall be presented when the message is transmitted as described in subclause 8.15.

Reference:

ETS 300 133-5 [3], subclause 7.8.

4.6.28 Tenure of group messages

The receiver shall not present a group message which appears any later than the batch before the next addressing opportunity on that channel when the message is transmitted as described in subclause 8.16.

Reference:

ETS 300 133-5 [3], subclause 7.9.

4.6.29 Recognition of FSI

When a receiver's FSN is not compatible with the transmitted FSI, the receiver shall not receive messages on that channel (see ETS 300 133-4 [2] subclause 10.2). It is required that the receiver shall only receive messages when the FSI is compatible with the receiver's FSN. Thus for steps 1 to 4 in the tests described in subclause 8.17 message 1 shall be received by the receiver and in step 5 message 2 shall be received.

Reference:

ETS 300 133-5 [3], subclause 7.2.6.

4.6.30 Multioperator environment

When the operator identity transmitted differs from the home operator identity stored in the receiver and the ETI is set to zero, the receiver shall not receive messages transmitted on that channel. It is required that the receiver shall not present messages that are transmitted as described in subclause 8.18.

Reference:

ETS 300 133-5 [3], subclause 7.1.8.

4.6.31 RSVD bits

Receiver behaviour with respect to the functional requirements of subclauses 4.6.13 to 4.6.30 shall not be modified by any combination of RSVD bit values. Conformance to this requirement shall be declared by the manufacturer in a manufacturers declaration (see subclause 4.3.1 c)).

Reference:

ETS 300 133-5 [3], subclause 7.13.

4.6.32 Additional features

The receivers behaviour with respect to the requirements of subclauses 4.6.1 to 4.6.31 shall not be modified by any additional features provided by the receiver. Conformance to this requirement shall be declared by the manufacturer in a manufacturers declaration (see subclause 4.3.1 e)).

Reference:

ETS 300 133-5 [3], subclause 6.1.

4.7 Interpretation of measurement results

The interpretation of the results recorded in a test report for the measurements described in this TBR shall be as follows:

- a) the measured value compared to the limit shall be used to determine whether the receiver meets the requirements of this TBR;
- b) the measurement uncertainty value for the measurement of each parameter shall be included in the test report;
- c) the values of the actual measurement uncertainty shall be, for each measurement, equal to or lower than the figures given in annex B, clause B.7.

5 General test requirements

5.1 Test philosophy

The test philosophy of all tests described in this TBR assumes that the Equipment Under Test (EUT) is a portable radio terminal with an integral antenna. Therefore the tests do not require any antenna connector to be used and they also assume that if any conductive or non-conductive material is in the close vicinity (< 1 wavelength), the radio parameters of the EUT may be affected.

A suitable test site shall be used when conducting measurements to determine the average usable sensitivity and the radiated spurious components. These are described in annex B, clauses B.4 and B.5.

5.2 Receiver to be submitted for conformance testing

One receiver sample shall be provided for testing.

The receiver shall be programmed with the RIC number:

010 0000001 010 1100011000111001 00 0000

The frequency subset number of the receiver shall be set to 3 (0011).

Further additional RICs which may be incorporated shall be considered as additional functions (see subclause 5.7).

5.3 Normal test conditions

The normal test conditions shall be at a value within the range:

- temperature: + 15 °C to + 35 °C; and
- relative humidity: 20 % to 75 %, non condensing.

The normal test voltage shall be that declared by the manufacturer.

5.4 Extreme test conditions

The extreme test conditions shall be:

- temperature: - 10 °C and + 55 °C; and
- relative humidity: non condensing.

The extreme test voltages shall be declared by the manufacturer.

When tests are to be carried out under extreme test conditions, the tests shall be carried out at the following temperatures:

- - 10 °C;
- + 55 °C;

at the maximum and minimum voltages specified by the manufacturer.

5.5 Test fixture

A calibrated test fixture shall be used for all tests unless otherwise stated. Test fixtures to enable tests under extreme voltage and temperature conditions shall be provided by the manufacturer, if required by the test laboratory.

All test fixtures shall conform to the requirements of annex B, clause B.6.

5.6 Test paging signal

The transmissions shall be in accordance with ETS 300 133-4 [2].

The batch structure used during testing shall contain one address in the address partition followed by one message in the message partition as shown in subclause 7.2, unless otherwise specified.

The test paging message to the receiver under test may be tone-only, 10 numeric characters or 55 alphanumeric characters according to the feature under test.

5.6.1 Successful tone-only call

A successful tone-only call occurs when the receiver presents an alert as declared by the manufacturer (see subclause 4.3.1). The full error capability of the code may be used.

5.6.2 Successful numeric message

For successful numeric calls the receiver shall present the transmitted test paging message as declared by the manufacturer (see subclause 4.3.1) correctly without error. The full error capability of the code may be used. A character in error is defined as a character that differs from the transmitted character.

5.6.3 Successful alphanumeric message

For successful alphanumeric calls, the receiver shall present the transmitted test paging message as declared by the manufacturer (see subclause 4.3.1), except as allowed in the average usable sensitivity test defined in annex A, clause A.1. The full error capability of the code may be used. A character in error is defined as a character that differs from the transmitted character.

5.7 Declared category

5.7.1 General

It is required that the manufacturer declares the category of the receiver (see subclause 4.3.1). All requirements specified in clause 6, unless otherwise stated, shall only consider the declared category function. As an example, if a manufacturer declares that a receiver is an alphanumeric receiver, then this receiver shall only be tested using the alphanumeric function. Exceptions to this are tests associated with requirements 1, 2, 3 and 6 (see subclause 5.7.2) and tests associated with requirements 24, 25 and 27, where the tone and numeric functions are tested.

5.7.2 Test time saving procedure

To reduce the time required for testing, tests associated with requirements 1, 2, 3 and 6 in clause 6 may test only the tone-only function. For receivers declared to be in one of the categories 1, 2 or 3 (see subclause 4.5), a tone-only function shall be tested. For receivers in category 4, a manufacturer's declaration with a suitable test is required (see subclause 4.3.1 h)). For receivers in the numeric and alphanumeric categories, there is a differential between the performance of a receiver using the tone-only function and its declared category function, therefore, for tests associated with requirements 1, 2 and 3, it shall be necessary to correct the test result obtained using the tone-only function. For this purpose a numeric differential factor and an alphanumeric differential factor have been defined (see annex B, clause B.9). These factors are added to the results obtained using the tone-only function in order to obtain the test result for the relevant category function. If a similar time saving procedure is used for transparent data receivers, then the test laboratory shall ensure that the method proposed in the manufacturer's declaration is satisfactory.

EXAMPLE: For the test associated with requirement 1, the sensitivity under normal conditions using the tone-only function, a test result of 21,5 dB μ V/m was obtained. The receiver was declared to be an alphanumeric receiver and the alphanumeric differential factor was found to be 2 dB. Therefore, the alphanumeric sensitivity is then calculated to be 23,5 dB μ V/m. Since this is below the limit set in clause 7, the receiver has passed this test.

6 TBR requirements table

Table 2: TBR-RT

TBR reference					
No	Reference subclause	TBR-R	Status	Support	Comment
1	4.6.1	Sensitivity (normal)	M		
2	4.6.2	Sensitivity (switching)	M		
3	4.6.3	Sensitivity (ext+offset)	M		
4	4.6.4	Co-channel	M		
5	4.6.5	Adjacent channel	M		
6	4.6.6	Adjacent channel (ext.)	M		
7	4.6.7	Spurious response	M		
8	4.6.8	Inter-modulation	M		
9	4.6.9	Blocking	M		
10	4.6.10	Input range	M		
11	4.6.11	Multi-path & quasi-synchronous	M		
12	4.6.12	Spurious emissions	M		
13	4.6.13	Last in batch	M		
14	4.6.14	Next batch	M		
15	4.6.15	Last batch	M		
16	4.6.16	Tenure of message	M		
17	4.6.17	Two messages	M		
18	4.6.18	Next sub-sequence	M		
19	4.6.19	All channels	M		
20	4.6.20	Zone code	M		
21	4.6.21	Two messages	M		
22	4.6.22	BAI = 1	M		
23	4.6.23	BAI = 0	M		
24	4.6.24.1	Tone-only	C{3}		
25	4.6.24.2	Numeric message	C{1}		
26	4.6.24.3	Alphanumeric message	C{2}		
27	4.6.25	Termination (numeric)	C{1}		
28	4.6.26	Termination (alpha)	C{2}		
29	4.6.27	Group call	M		
30	4.6.28	Tenure of group call	M		
31	4.6.29	Recognition of FSI	M		
32	4.6.30	Multioperator environment	M		
33	4.6.31	RSVD	M		
34	4.6.32	Additional features	M		
Conditional statements:					
	C{1}	M when receiver is of the numeric or alphanumeric category else N.			
	C{2}	M when receiver is of the alphanumeric category else N.			
	C{3}	M when receiver is of alphanumeric, numeric or tone-only category else N.			
NOTE:	M in the column titled "Status" means that the requirement is mandatory, whilst if the conditional statement equates to N, then the requirement is not relevant.				

7 Tests for radio parameter conformance

7.1 Conformance requirements

The receiver supplied shall meet or exceed the following performance criteria when measured in accordance with methods of measurement defined in subclause 7.2.

Table 3

	Requirement	Method of measurement subclause	Limit value
a)	the average usable sensitivity under normal conditions.	7.2 a)	25 dB μ V/m
b)	the maximum degradation in required sensitivity (annex B, clause B.8) under switching channel conditions.	7.2 l)	0 dB;
c)	the maximum degradation in required sensitivity (annex B, clause B.8) under extreme temperature and voltage conditions with a transmitter frequency offset of \pm 200 Hz.	7.2 c)	6 dB;
d)	co-channel rejection under normal conditions.	7.2 e)	- 10 dB;
e)	adjacent channel selectivity under normal conditions.	7.2 f)	60 dB;
f)	adjacent channel selectivity under extreme conditions.	7.2 f)	50 dB;
g)	spurious response immunity under normal conditions.	7.2 g)	76 dB μ V/m;
h)	intermodulation immunity under normal conditions.	7.2 h)	70 dB μ V/m;
j)	blocking immunity or desensitisation under normal conditions.	7.2 j)	84 dB μ V/m;
k)	Maximum usable input level under normal conditions.	7.2 d)	3 V/m;
l)	The maximum degradation in sensitivity for combined multi-path and quasi-synchronous transmissions under normal conditions.	7.2 k)	15 dB;
m)	spurious emissions under normal conditions: 30 MHz - 1 GHz: 1 GHz - 4 GHz : ERMES channels:	7.2 b)	2 nW; 20 nW; 2 pW.

7.2 Method of measurement

Measurements shall be conducted on ERMES frequency number 8 (see ETS 300 133-4 [2], subclause 8.2) unless otherwise stated. The measurements shall be conducted according to the following steps: the transmission used for these tests shall be constructed as follows:

PR	SYN	SI	SI	SSI	IA	4 *APT	MD	MESSAGE	MD
----	-----	----	----	-----	----	--------	----	---------	----

NOTE: MESSAGE: a message appropriate to receiver under test.
 MD: message delimiter.

For all the measurements in this subclause, consideration shall be given to the time constraints as declared by the manufacturer in subclause 4.3.1 (f),(n) and (o).

- a) the average usable sensitivity expressed as the field strength shall be measured as described in annex A, clause A.1. The test site (see annex B, clause B.4) shall be complemented with a "simulated man" (see annex B, clause B.1). Any ERMES frequency may be used;
- b) the measurement procedure for spurious radiation shall be carried out as described in annex A, clause A.2;
- c) the measurement of the sensitivity shall be repeated under normal and extreme conditions together with a transmitter offset of 200 Hz in a test fixture complying with annex B, clause B.6, according to annex A, subclause A.1.2 steps b) to e) (see annex B, clause B.8);
- d) measurement of usable input level range: the receiver shall correctly present four messages out of four. The test shall be carried out in a test fixture as defined in annex B, clause B.6 with the wanted signal adjusted so that the field strength at the receiver shall be 3 V/m;
- e) measurement of the co-channel rejection shall be carried out as described in annex A, clause A.3;

- f) the measurement of the adjacent channel selectivity under normal and extreme conditions shall be carried out as described in annex A, clause A.4;
- g) the measurement of the spurious response immunity shall be carried out as described in annex A, clause A.5;
- h) the measurement of intermodulation immunity shall be carried out as described in annex A, clause A.6;
- j) the measurement of the blocking immunity or desensitisation shall be carried out as described in annex A, clause A.7;
- k) the measurements of quasi-synchronous sensitivity combined with multi-path shall be made at a simulated speed of 3 km/h. A second signal with the same data content but delayed 50 μ s, 1 dB weaker and 30 Hz Radio Frequency (RF) frequency offset shall be added. The test procedure is given in annex A, clause A.8 (see annex B, clause B.8);
- l) channel switching: the sensitivity shall be measured in an appropriate test fixture (annex B, clause B.6) with a test signal according to annex A, subclause A.1.2 steps b) to e): a batch shall be transmitted consisting of 139 initial addresses numerically higher than the initial address of the receiver under test. This shall be immediately followed by the test message shown in ETS 300 133-5 [3], subclause 7.1.1, transmitted on the appropriate channel (see ETS 300 133-4 [2], figure 3). The signal strength of both channels shall remain constant during the test. Both transmissions shall occur in batches of the same type (i.e. same batch number) within the same subsequence; both channels shall broadcast a network identity different from the receiver's OPID. The ETI shall be set to 1 for both channels.

8 Tests for radio interface conformance

This clause defines tests associated with the requirements 13 - 32 in clause 6. All tests shall be performed in a suitable test fixture conforming to annex B, clause B.6 with a signal level approximately + 30 dB relative to the reference figure of that test fixture. Unless otherwise stated, the tests should be carried out after the receiver has reached steady state conditions.

The test protocol used in this clause complies with ETS 300 133-4 [2]. Part of subclause 4.4 of ETS 300 133-4 [2] is reproduced here to identify the test parameters.

PR	SYN	SI	SI	SSI	I * IA	J * APT	K * CODEBLOCKS
SYNCH PART	SYSTEM INF PARTITION	ADDRESS PARTITION		MESSAGE PARTITION			

NOTE:	PR SYN SI SSI IA APT CODE BLOCK I J K	preamble word. synchronisation word. system information word. supplementary system information word. initial address. address partition terminator. interleaved message code word. number of initial addresses. number of address partition terminators. number of code blocks in the message partition.
-------	--	---

Figure 1

Code word composition of a batch satisfies the following relationships:

$$0 \leq I \leq 139;$$

$$J = 9 - \text{MOD}\{(4+I), 9\} \quad \text{where} \quad \text{MOD}\{M, N\} = M - N * \text{INT}(M/N) \text{ and INT returns the integer part of a number;}$$

$K \leq (149 - I - J)/9$ first 15 batches of a sub-sequence;
 $K \leq (185 - I - J)/9$ last batch of a sub-sequence.

Test transmissions in subclauses 8.1 to 8.18 inclusive shall be realised in a multioperator environment. In all tests the PA code shall be set to 000000. For subclauses 8.1 to 8.6, on channel 8, the zone and operator details contained within the system information partition shall indicate home network transmissions to the receiver; the BAI shall be set to 0, and the FSI to 30. Channel 10 (see ETS 300 133-4 [2] subclause 8.2) shall have the same signal strength, and shall indicate a network identity different from the receiver's OPID; its BAI shall be set to 0, and its FSI to 30.

For subclauses 8.7 to 8.18, at least two channels with different network identities shall be used.

8.1 Last message in batch

The test transmission shall be as shown in figure 2:



NOTE PAD: an initial address, higher than the receiver under test, used to occupy start of address partition.
 FILL: code words other than MD and having no EOM characters used to occupy inactive parts of the message partition.

Figure 2

The message for the receiver under test shall be positioned so that the message delimiter after the message shall be the last code word in the batch containing the initial address for the receiver.

8.2 Message continued in next batch

The test transmission shall be as follows:

The message delimiter MD, which prefaces the message, is the last code word in the batch containing the initial address for the receiver. The message is then completed in the batch shown in figure 3.

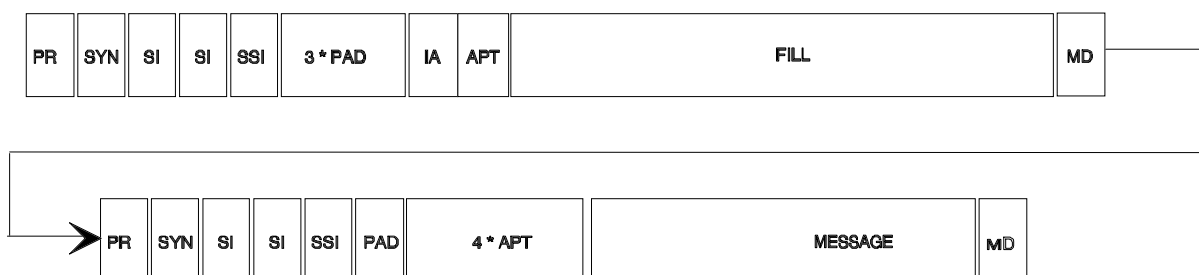

Figure 3

8.3 Message in last available batch

The test transmission shall be as shown in figure 4.



followed by 14 batches constructed as:

PR	SYN	SI	SI	SSI	5 * APT	FILL				
----	-----	----	----	-----	---------	------	--	--	--	--

and a final batch of:

PR	SYN	SI	SI	SSI	4 * PAD	APT	FILL	MD	MESSAGE	MD
----	-----	----	----	-----	---------	-----	------	----	---------	----

Figure 4

The batch containing the message may be in the sub-sequence following the sub-sequence containing the initial address.

8.4 Tenure of message

The test transmission shall be as shown in figure 5.

PR	SYN	SI	SI	SSI	3 * PAD	IA	APT	FILL		
----	-----	----	----	-----	---------	----	-----	------	--	--

followed by 15 batches constructed as:

PR	SYN	SI	SI	SSI	5 * APT	FILL				
----	-----	----	----	-----	---------	------	--	--	--	--

and a final batch of:

PR	SYN	SI	SI	SSI	4 * PAD	APT	FILL	MD	MESSAGE	MD
----	-----	----	----	-----	---------	-----	------	----	---------	----

Figure 5

The batch containing the message shall be in the sub-sequence following the sub-sequence containing the initial address.

8.5 Two messages in same batch

The test transmission shall be as shown in figure 6.

PR	SYN	SI	SI	SSI	2 * PAD	IA	IA	APT	MD	MESSAGE1	MD	MESSAGE2	MD
----	-----	----	----	-----	---------	----	----	-----	----	----------	----	----------	----

Figure 6

The two IA are identical and are for the receiver under test. The two messages shall be distinguishable.

8.6 Message continued in the next sub-sequence

The test transmission shall be as follows: the MD, which prefaces the message, is the last code word in the last batch of the sub-sequence containing the initial address. The message shall be completed in the first batch of the next sub-sequence.

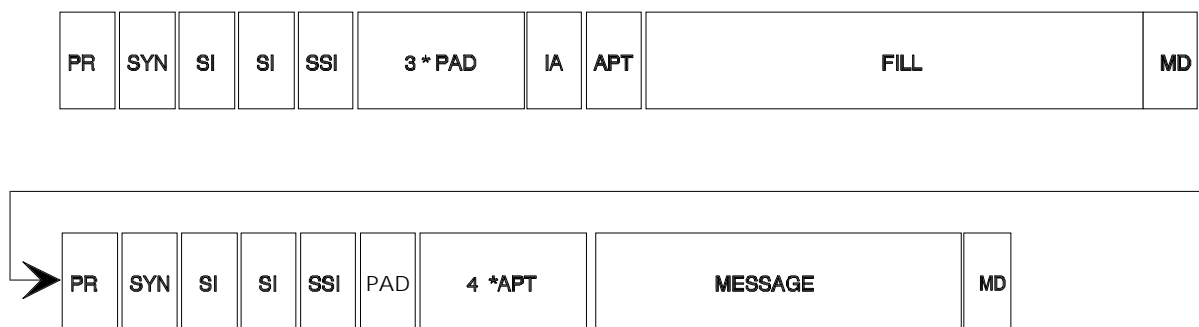

Figure 7

8.7 Message reception on all ERMES channels

The test transmission shall be as follows:

The operator code shall not be the receiver's home operator's code. The SI shall indicate the presence of an external message and the message shall be constructed so that the receiver should be able to receive it (see ETS 300 133-5 [3], subclause 7.2.1).

Transmissions shall be on each of the ERMES channels.

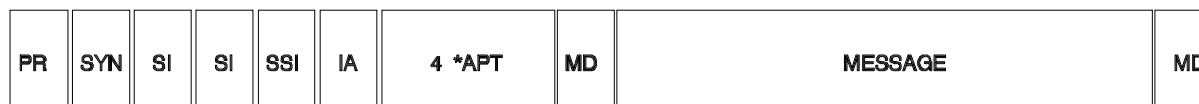

Figure 8

Bit and word synchronisation shall not be maintained between channels and at least two transmissions shall be at the extreme of allowable network co-ordination (see ETS 300 133-4 [2], subclause 12.4).

8.8 Recognition of zone code

The test transmission shall be as follows: a message to a home receiver with the same local address as the receiver under test. The zone code in the SSI word shall be different from the home zone of the receiver.

8.9 Two messages in the same batch

The test transmission shall be constructed as follows: the initial addresses for both messages shall be the same. The SI shall contain an operator identity different to the receiver's operator identity. Message 1 is for the home receiver, message 2 is for the external receiver under test.

NOTE: The PAD in this case will be an initial address lower than that of the receiver under test.



Figure 9

8.10 Message reception in overlap regions (BAI = 1)

The test transmission shall be constructed as follows:

A transmission on two channels shall be constructed. One channel indicating the home network shall be transmitted on channel 8 and the other channel shall indicate a non-home network. On the home channel the BAI shall be set to one. They shall be constructed as shown below: The two messages MESSAGE1

and MESSAGE2 shall be of different content. Messages shall be completed in the batch containing the initial address.

Channel 8



Non-home channel



Figure 10

8.11 Message reception in overlap regions (BAI = 0)

The test transmission shall be constructed as follows: a continuous transmission indicating the home network shall be sent to the receiver. The BAI shall be set to zero. The reception quality on the channel shall then be reduced to a level corresponding to a call success rate not more than 60 %. An external message on a non-home network channel shall be constructed as illustrated below.

The method to simulate insufficient quality of reception (BER, code word error rate, erroneous system information) and the time constraints shall be stated by the receiver manufacturer.

Channel 8

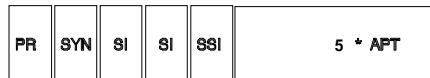

Non home channel.



Figure 11

8.12 Messages

In the messages sent in tests in this subclause, the data transmitted shall indicate a home network.

8.12.1 Tone message (alert signal indicator bits "000")

The test transmission shall be constructed as follows: a message constructed as in ETS 300 133-5 [3] subclause 7.1.1 with the paging category bits set to 00 shall be transmitted. In the test transmission the alert bits in the message header shall be set to 000. The message shall consist only of the message header (see ETS 300 133-4 [2], subclause 5.5.1).

8.12.2 Maximum length numeric message

The test transmission shall be constructed as follows: a message constructed as in ETS 300 133-5 [3], subclause 7.1.1 with the paging category bits set to 01 shall be transmitted. The message consisting of 20 numeric characters using all the characters described in annex C, table C.1 shall transmitted, at least once, in the same batch as the initial address.

8.12.3 Maximum length alphanumeric message

The test transmission shall be constructed as follows: A message constructed as in ETS 300 133-5 [3], subclause 7.1.1 with the paging category bits set to 10 shall be transmitted. A message consisting of 400 alphanumeric characters using all the characters described in annex C, table C.3 shall be transmitted, at least once, except for DC1, as shown below.

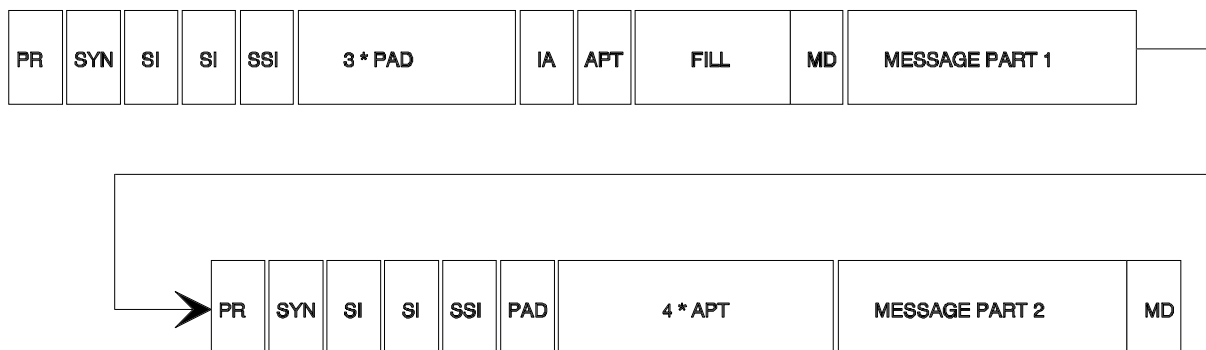

Figure 12

The message shall be split between the end of the first batch and the start of the next batch.

8.13 Termination of numeric messages due to reception errors

The test transmission shall be constructed as follows: a message as defined in ETS 300 133-5 [3], subclause 7.1.1 shall be sent to the receiver. In the message part after the message header, 18 numeric characters shall be transmitted, namely 123456789012345678. The second code word shall contain three bits in error. In the message header the External Bit (EB) and the Additional Information Indicator (All) shall both be set to zero.

8.14 Termination of alphanumeric messages

The test transmission shall be constructed as shown in figure 13.



Figure 13

In the transmission, both the code words containing the EOM and the message delimiter, are in error.

NOTE: A code word in error is defined as having three bits in error.

8.15 Group call

The test shall be constructed as follows: the transmission shown below illustrates the position for the message. The IA shall be transmitted.

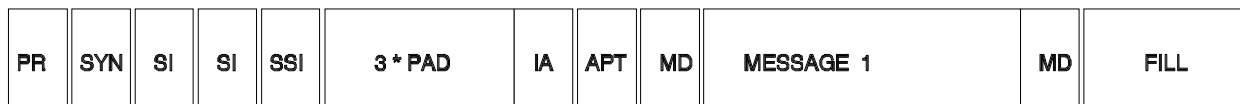

followed by 14 batches constructed as:

PR	SYN	SI	SI	SSI	5 * APT	FILL				
----	-----	----	----	-----	---------	------	--	--	--	--

and a final batch of:

PR	SYN	SI	SI	SSI	4 * PAD	APT	FILL	MD	GROUP MESSAGE	MD
----	-----	----	----	-----	---------	-----	------	----	---------------	----

Figure 14

MESSAGE 1 contains the CTAP 0100 as described in ETS 300 133-4 [2], subclauses 5.5.1.2.4 and 10.3.

8.16 Tenure of group message

The test transmission shall be constructed as follows: the IA shall be transmitted in a batch as shown in figure 15.

PR	SYN	SI	SI	SSI	3 * PAD	IA	APT	MD	MESSAGE 1	MD	FILL
----	-----	----	----	-----	---------	----	-----	----	-----------	----	------

and followed by 15 batches, constructed as:

PR	SYN	SI	SI	SSI	5 * APT	FILL				
----	-----	----	----	-----	---------	------	--	--	--	--

and a final batch of:

PR	SYN	SI	SI	SSI	4 * PAD	APT	FILL	MD	GROUP MESSAGE	MD
----	-----	----	----	-----	---------	-----	------	----	---------------	----

Figure 15

The contents of MESSAGE 1 and the group message shall be identical to that given in subclause 8.15.

8.17 Recognition of FSI

The test transmission shall be as follows:

The receiver's FSN is set to 3.

Table 4

	Channel 8	Channel 10
step 1	FSI=3 BAI=0 home OPID message 1	FSI=30 BAI=0 external OPID message 2
step 2	FSI=17 BAI=0 home OPID message 1	FSI=30 BAI=0 external OPID message 2
step 3	FSI=24 BAI=0 home OPID message 1	FSI=30 BAI=0 external OPID message 2
step 4	FSI=28 BAI=0 home OPID message 1	FSI=30 BAI=0 external OPID message 2
step 5	FSI=29 BAI=0 home OPID message 1	FSI=30 BAI=0 external OPID message 2

Message 1 and message 2 shall be transmitted in the same subsequence.

Message 1 shall be transmitted as described in ETS 300 133-5 [3] subclause 7.1.1 ("First message in batch"). Message 2 shall be transmitted as described in ETS 300 133-5 [3] subclause 7.2.1 ("Message reception on all ERMES channels "). The wording "message 1" and "message 2" refers to messages of different contents or to different alert types.

8.18 Multioperator environment

Two channels with different network identities shall be used. On one of the channels, a transmission shall be constructed which contains a message to a home receiver with the same local address as the receiver under test. The operator code in the SI partition shall be different from the home operator identity of the receiver under test. The receiver shall not receive the message

Annex A (normative): Measurement procedures

A.1 Average measured usable sensitivity expressed as field strength under normal conditions

A.1.1 Definition

The average measured usable sensitivity expressed as field strength for messages is the average of eight measurements of field strength, expressed in dB μ V/m, at the nominal frequency of the receiver and with specified test modulation which produces after demodulation a message acceptance ratio of 80 %, when the receiver is rotated in 45° increments, starting at the reference orientation.

If the test time saving procedure is used (see subclause 5.7.2), and this measurement uses a tone-only message, then the differential factor relevant to the receiver declared category (annex B, clause B.9) shall be added to the result obtained in subclause A.1.1 e).

For the purposes of this annex, the following definition shall apply:

successful alphanumeric message: for successful alphanumeric calls the receiver shall present a 55 character message as declared by the manufacturer (see subclause 4.3.1) with a maximum of four contiguous characters in error.

The full error capability of the code may be used. A character in error is defined as a character that differs from the transmitted character.

A.1.2 Method of measurement

This measurement method produces a message acceptance ratio of 80 %:

- a) a test site which fulfils the requirements of the specified frequency range of this measurement shall be used (see annex B, clause B.4). The transmitting antenna shall be oriented for vertical polarisation;

A signal generator shall be connected to the transmitting antenna. The signal generator shall be at the nominal frequency of the receiver and shall be modulated by the test paging signal (see subclause 5.6). The receiver under test shall be placed on the "simulated man" (see annex B, clause B.1) at $1,0 \pm 0,1$ metre above ground level and oriented so that a face, declared by the manufacturer, is normal to the direction of the transmitting antenna (see subclause 4.3.1 I)). This is the reference orientation for the measurement.

- b) the level of the RF signal shall be such that a successful message response ratio of less than 10 % is obtained;
- c) the test paging signal shall be transmitted repeatedly while observing in each case whether or not a successful response is obtained. The input level shall be increased by 2 dB for each occasion that a successful response is not obtained. The procedure shall be continued until three consecutive successful responses are observed;
- d) the input signal level shall be reduced by 1 dB and the new value recorded. The test paging signal shall then be continuously repeated. In each case, if a response is not obtained, the input level shall be increased by 1 dB and the new value recorded. If a successful response is obtained, the input level shall not be changed until three consecutive successful responses have been observed. In this case, the input level shall be reduced by 1 dB and the new value recorded. No input signal levels shall be recorded unless preceded by a change in level. The measurement shall be stopped after 10 values have been recorded;
- e) the mean average of the dB values recorded in step d) shall be calculated;
- f) steps b) to e) above shall be repeated for the eight positions, 45° apart, of the receiver and the corresponding average values of the generator output shall be determined and noted;

- g) using the calibration of the test site (see annex B, clause B.4), the eight field strengths X_i ($\mu\text{V}/\text{m}$) corresponding to the eight average values determined in step f) shall be calculated. The average measured usable sensitivity expressed as field strength X_{mean} ($\text{dB}\mu\text{V}/\text{m}$) is given by:

$$X_{\text{mean}} = 20 \log_{10} \left[\frac{8}{\sum_{i=1}^{i=8} \left(\frac{1}{X_i} \right)^2} \right]^{1/2}$$

A.2 Radiated spurious components

A.2.1 Definition

Radiated spurious components are emissions radiated by the antenna and the cabinet of the receiver. They are specified as the radiated power of any discrete signal.

A.2.2 Method of measurement

The following method of measurement shall be used:

- a) a test site which fulfils the requirements of the specified frequency range of this measurement shall be used (see annex B, clause B.5). The measuring antenna as defined in annex B, subclause B.5.2.5, shall be oriented for vertical polarisation and connected to a selective measuring device (see annex B, subclause B.5.2.8). The bandwidth of the selective measuring device shall be 10 kHz if the frequency is within the ERMES band and 100 kHz if it is outside the ERMES band. The peak mode of measurement shall be selected. The specified height range of the measuring antenna above the ground plane shall be between 1,0 m and 4,0 m. The minimum height may be higher depending on the physical characteristics of the measuring antenna (practical limitations);

The receiver under test shall be placed on a non-conducting support in its standard position as declared by the manufacturer.

- b) the radiation of any spurious component shall be detected by the measuring antenna and receiver over the specified frequency range. The frequency of each spurious component shall be recorded. If the test site is disturbed by radiation coming from outside, this qualitative search may be performed in a screened room with reduced distance between the transmitter and the measuring antenna;
- c) at each frequency at which a component has been detected, the selective measuring device shall be tuned and the measuring antenna shall be raised or lowered through the height range until the maximum signal level is detected on the selective measuring device;
- d) the receiver shall be rotated up to 360° about a vertical axis, until the maximum signal is received. This position shall be recorded and the measuring antenna left in this position;
- e) the measuring antenna shall be raised or lowered again through the specified height range until a maximum is obtained. This level shall be recorded;
- f) the substitution antenna (as defined in annex B, subclause B.5.2.6) shall replace the receiver in the same position and in vertical polarisation (see annex B, subclause B.4.2.6). The substitution antenna shall be a calibrated dipole antenna and be connected to the signal generator;
- g) for each frequency at which a component has been detected, the signal generator and selective measuring device shall be tuned and the measuring antenna shall be raised or lowered through the specified height range until the maximum signal level is detected on the selective measuring device. The level of the signal generator giving the same signal level on the selective measuring device as in item e) above shall be recorded. This value, after correction due to the gain of the substitution

antenna and the cable loss between the signal generator and the substitution antenna, is the radiated spurious component at this frequency;

- h) measurements b) to g) above shall be repeated with the measuring antenna and substitution antenna oriented in horizontal polarisation.

A.3 Co-channel rejection

A.3.1 Definition

Co-channel rejection is a measure of the capability of the receiver to receive a wanted modulated signal at the nominal frequency without exceeding a given degradation due to the presence of an un-wanted modulated signal also at the nominal frequency.

It is defined as the ratio in dB of the level of the un-wanted signal to the specified wanted signal level at the receiver input, for which the message acceptance ratio is 80 %. The wanted signal level shall correspond to the reference figure (see annex B, clause B.3).

A.3.2 Method of measurement

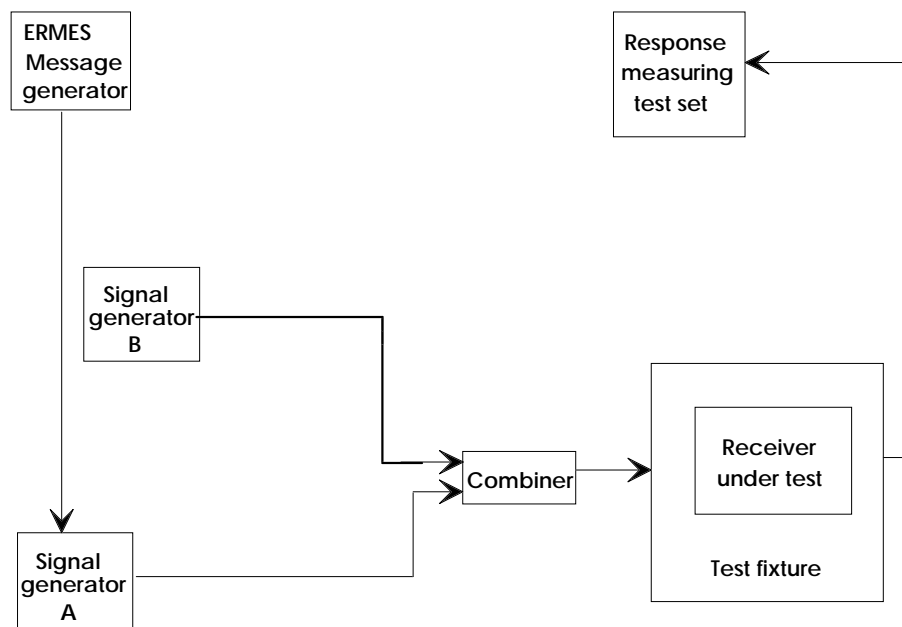

Figure A.1: Measurement arrangement

The test fixture shall meet the requirements of annex B, subclause B.6.

- a) two signal generators A and B shall be connected to the receiver input via a combining network (see figure A.1). The wanted signal, represented by the 4-PAM/FM signal generator A, shall be a carrier frequency and shall have the test modulation as defined in subclause 5.6. The un-wanted signal, represented by signal generator B, shall have the test modulation defined in annex B, clause B.2. Both input signals shall be at the nominal frequency of the receiver under test;
- b) initially, signal generator B shall be switched off. The amplitude of signal generator A shall be adjusted to the wanted signal level when measured at the input of the test fixture;
- c) generator B shall then be switched on, and its input level adjusted until a message response ratio of less than 10 % is obtained;
- d) the wanted signal shall then be transmitted whilst observing the message response ratio. The level of the un-wanted signal shall be reduced in steps of 1 dB until a message response ratio of 80 % or better is obtained. The level of the un-wanted signal shall then be recorded;

- e) the un-wanted input signal shall then be increased by 1 dB and the new value recorded. The wanted signal shall then be continuously repeated. In each case if a response is not obtained, the level of the un-wanted signal shall be reduced by 1 dB and the new value recorded. If a successful response is obtained, the level of the un-wanted signal shall not be changed until three consecutive successful responses have been obtained. In this case the un-wanted signal shall be increased by 1 dB and the new value recorded. No levels of the un-wanted signal shall be recorded unless preceded by a change in level. The measurement shall be stopped after a total of 10 values have been recorded;
- f) the mean average of the dB values recorded in step e) shall be calculated;
- g) the co-channel rejection ratio for messages shall be recorded as the ratio in dB of the value calculated in f) to the level of the wanted signal, at the input of the test fixture.

A.4 Adjacent channel selectivity

A.4.1 Definition

The adjacent channel selectivity for paging messages is a measure of the capability of the receiver to receive a wanted signal at the nominal frequency modulated by a test signal, without exceeding a given degradation due to the presence of an un-wanted modulated signal which differs in frequency from the wanted signal by an amount equal to the adjacent channel separation for which the equipment is intended. The wanted signal level shall correspond to the reference figure (see annex B, clause B.3). For measurements under extreme conditions the maximum degradation as specified in 7.1.c) shall be added to this reference figure.

It is defined as the lower value of the ratios in dB for the upper and lower adjacent channels of the level of the un-wanted signal to the specified level of the wanted signal for which the message acceptance ratio is 80 %.

A.4.2 Method of measurement

The test fixture shall comply with the requirements of annex B, clause B.6.

The following method of measurement shall be used:

- a) two signal generators, A and B shall be connected to the receiver via a combining network (see figure A.1). The wanted signal, produced by the 4-PAM/FM signal generator A, shall be a carrier frequency and test modulation as defined in subclause 5.6. The un-wanted signal, produced by signal generator B, shall have the modulation defined in annex B, clause B.2 and shall be adjusted to the frequency of the channel immediately above that of the wanted signal;
- b) initially signal generator B shall be switched off. The amplitude of signal generator A shall be adjusted to the wanted signal level when measured at the input of the test fixture;
- c) the wanted signal shall then be transmitted repeatedly and the signal generator B shall be switched on. The input level of the un-wanted signal shall be adjusted until a successful message ratio of less than 10 % is obtained;
- d) the level of the un-wanted signal shall be reduced by 2 dB for each occasion that a successful response is not observed. The procedure shall be continued until three consecutive successful responses are observed. The level of the input signal shall then be recorded;
- e) the unwanted input signal shall then be increased by 1 dB and the new value recorded. The wanted signal shall then be continuously repeated. In each case if a response is not obtained, the level of the un-wanted signal shall be reduced by 1 dB and the new value recorded. If a successful response is obtained, the level of the un-wanted signal shall not be changed until three consecutive successful responses have been obtained. In this case the un-wanted signal shall be increased by 1 dB and the new value recorded. No levels of the un-wanted signal shall be recorded unless preceded by a change in level. The measurement shall be stopped after a total of 10 values have been recorded;

- f) measurements a) to e) above shall be repeated with the un-wanted signal at the frequency of the channel below that of the wanted signal;
- g) the adjacent channel selectivity for messages shall be recorded for the upper and lower adjacent channels as the ratio in dB of the average of the levels of the un-wanted signal recorded in steps d) and e) to the level of the wanted input signal.

A.5 Spurious response immunity

A.5.1 Definition

The spurious response immunity for paging messages is a measure of the capability of the receiver to discriminate between the wanted signal modulated by a test signal at the nominal frequency and an un-wanted signal at any other frequency at which a response is obtained. Un-wanted signal frequencies shall be tested from 30 MHz to 1 GHz except for frequencies within 25 kHz of the wanted frequency. The wanted signal level shall correspond to the reference figure (see annex B, clause B.3).

Spurious response immunity is defined as the level of the un-wanted signal for which the message acceptance ratio is 80 %.

A.5.2 Method of measurement

The test fixture shall meet the requirements of annex B, clause B.6.

The following method of measurement shall be used:

- a) two signal generators, A and B shall be connected to the receiver via a combining network (see figure A.1). The wanted signal, produced by the 4-PAM/FM signal generator A, shall be a carrier frequency and shall have the test modulation as defined in subclause 5.6. The un-wanted signal, produced by signal generator B, shall have the signal format defined in annex B, clause B.2 and shall be adjusted to a frequency within the specified frequency range at which it is calculated that a spurious response could occur (see annex B, clause B.10);
- b) initially, signal generator B shall be switched off. The amplitude of signal generator A shall be adjusted to the wanted signal level when measured at the input of the test fixture;
- c) the wanted signal shall then be transmitted repeatedly and the signal generator B shall be switched on. The input level of the un-wanted signal shall be adjusted until a successful message ratio of less than 10 % is obtained;
- d) the level of the un-wanted signal shall be reduced by 2 dB for each occasion that a successful response is not observed. The procedure shall be continued until three consecutive successful responses are observed. The level of the input signal shall then be recorded;
- e) the un-wanted input signal shall then be increased by 1 dB and the new value recorded. The wanted signal shall then be continuously repeated. In each case, if a response is not obtained, the level of the un-wanted signal shall be reduced by 1 dB and the new value recorded. If a successful response is obtained, the level of the un-wanted signal shall not be changed until three consecutive successful responses have been obtained. In this case the un-wanted signal shall be increased by 1 dB and the new value recorded. No levels of the un-wanted signal shall be recorded unless preceded by a change in level. The measurement shall be stopped after a total of 10 values have been recorded;
- f) the measurement shall be repeated at each frequency within the specified frequency range at which it is calculated that a spurious response could occur;
- g) the spurious response immunity for messages for the frequency concerned is the ratio in dB of the average of the levels of the un-wanted signal recorded in steps d) and e) to the level of the wanted signal, plus 28 dB and expressed in dB μ V/m.

A.6 Intermodulation immunity

A.6.1 Definition

The intermodulation immunity for paging signals is a measure of the capability of a receiver to receive a wanted signal at the nominal frequency modulated by a test signal without exceeding a given degradation due to the presence of two or more un-wanted signals with a specific frequency relationship to the wanted signal frequency.

For the purpose of this measurement it is defined as the common level of two equal un-wanted signals, for which the message acceptance ratio is 80 %. The wanted signal level shall correspond to the reference figure (see annex B, clause B.3).

A.6.2 Method of measurement

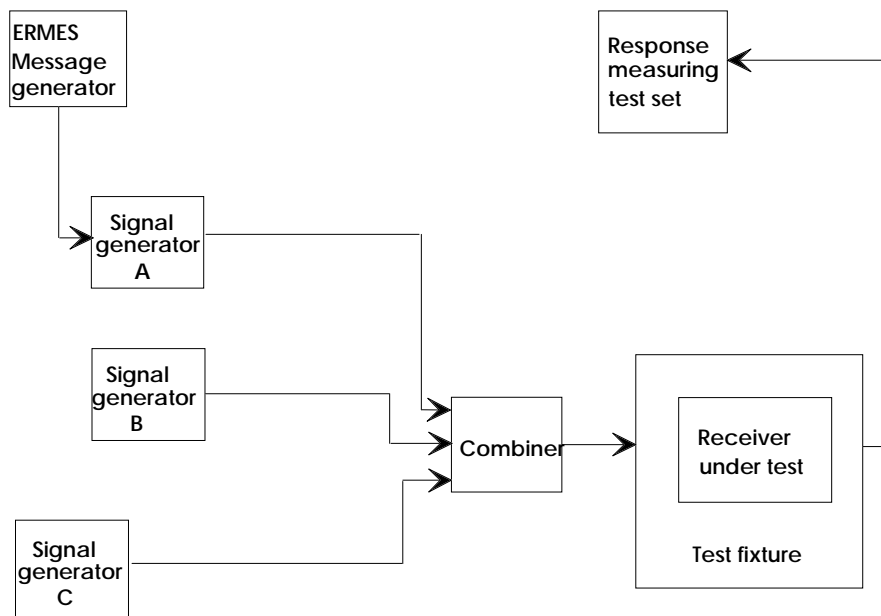

Figure A.2: Measurement arrangement (clause A.6)

The test fixture shall meet the requirements of annex B, clause B.6.

The following method of measurement shall be used:

- three signal generators, A, B and C, shall be connected to the receiver via a combining network (see figure A.2). The wanted signal, represented by the 4-PAM/FM signal generator A, shall be a carrier frequency and shall have the test modulation as defined in subclause 5.6. The first un-wanted signal, represented by the signal generator B, shall be un-modulated and adjusted to the frequency 50 kHz above the nominal frequency of the receiver. The second un-wanted signal, represented by the signal generator C, shall have the test modulation as defined in annex B, clause B.2 and shall be adjusted to a frequency 100 kHz above the nominal frequency;
- initially, signal generators B and C shall be switched off and the amplitude of signal generator A shall be adjusted to the wanted signal level when measured at the input of the test fixture;
- the wanted signal shall then be transmitted repeatedly and signal generators B and C shall be switched on. The output levels of signal generators B and C shall be maintained equal and adjusted to a value such that a successful message ratio of less than 10 % is obtained;
- the levels of the un-wanted signals shall be reduced by 2 dB for each occasion that a successful response is not observed. The procedure shall be continued until three consecutive successful responses are observed. The level of the input signal shall then be recorded;

- e) the un-wanted input signals shall then be increased by 1 dB and the new value recorded. The wanted signal shall then be continuously repeated. In each case, if a response is not obtained, the level of the un-wanted signals shall be reduced by 1 dB and the new value recorded. If a successful response is obtained, the level of the un-wanted signals shall not be changed until three consecutive successful responses have been obtained. In this case the un-wanted signals shall be increased by 1 dB and the new value recorded. No levels of the un-wanted signals shall be recorded unless preceded by a change in level. The measurement shall be stopped after a total of 10 values have been recorded;
- f) the intermodulation immunity for messages shall be recorded as the ratio in dB of the average of the levels of the un-wanted signals recorded in steps d) and e) to the level of the wanted signal, plus 28 dB and expressed in dB μ V/m;
- g) measurements a) to f) above shall be repeated with the un-wanted signal generator B at the frequency 50 kHz below that of the wanted signal and the frequency of the un-wanted signal generator C at the frequency 100 kHz below that of the wanted signal.

A.7 Blocking immunity

A.7.1 Definition

Blocking immunity for paging messages is a measure of the capability of the receiver to receive the wanted modulated signal at the nominal frequency without exceeding a given degradation due to the presence of an un-wanted un-modulated high input signal.

It is defined as the level of the un-wanted signal for which the message acceptance ratio is 80 %. The wanted signal level shall correspond to the reference figure (see annex B, clause B.3).

A.7.2 Method of measurement

The test fixture shall meet the requirements of annex B, subclause B.6.

The following method of measurement shall be used:

- a) two signal generators A and B shall be connected to the receiver input via a combining network (see figure A.1). The wanted signal, represented by the 4-PAM/FM signal generator A, shall be a carrier frequency and shall have the test modulation as defined in subclause 5.6;
- b) initially, the unwanted signal, represented by the signal generator B, shall be switched off and the amplitude of signal generator A shall be adjusted to the wanted signal level when measured at the input of the test fixture;
- c) the wanted signal shall then be transmitted repeatedly and the signal generator B shall be switched on. The un-wanted signal shall be un-modulated and its frequency shall be selected in the range $+1 \text{ MHz} \pm 10 \%$ relative to the nominal frequency of the receiver. This frequency shall be one at which no spurious response has been detected. The level of the un-wanted signal shall be adjusted until a successful message ratio of less than 10 % is obtained;
- d) the level of the un-wanted signal shall be reduced by 2 dB for each occasion that a successful response is not observed. The procedure shall be continued until three consecutive successful responses are observed. The level of the input signal shall then be recorded;
- e) the un-wanted input signal shall then be increased by 1 dB and the new value recorded. The wanted signal shall then be continuously repeated. In each case, if a response is not obtained the level of the un-wanted signal shall be reduced by 1 dB and the new value recorded. If a successful response is obtained, the level of the un-wanted signal shall not be changed until three consecutive successful responses have been obtained. In this case the un-wanted signal shall be increased by 1 dB and the new value recorded. No levels of the un-wanted signal shall be recorded unless preceded by a change in level. The measurement shall be stopped after a total of 10 values have been recorded;
- f) the measurements shall be repeated for frequency of the un-wanted signal selected in the range $-1 \text{ MHz} \pm 10 \%$, relative to the nominal frequency of the receiver;

- g) the blocking level for messages shall be recorded as the ratio in dB of the lower value of the two measurements above, of the average of the levels of the un-wanted signal recorded in steps d) and e) to the level of the wanted input signal, plus 28 dB and expressed in dB μ V/m.

A.8 Combined multi-path and quasi-synchronous transmissions

A.8.1 Definition

The multi-path combined with simulcast sensitivity of the receiver is the root mean square (rms) value of the level of the stronger Rayleigh fading signal, at the receiver input, at the nominal frequency of ERMES channel 8 with normal ERMES test modulation signal and a produced successful message ratio of 80 %. The wanted signal level shall correspond to the reference figure (see annex B, clause B.3).

A.8.2 Method of measurement

The following method of measurement shall be used:

- a) the two 4-PAM/FM signal generators (A and B) shall be connected to the receiver under test via Rayleigh fading simulators and a combiner (see figure A.3). The signal from generator A shall be on the nominal RF frequency and the signal from generator B on the nominal frequency + 30 Hz \pm 3 Hz. The fading simulators shall be adjusted for the simulated speed of 3 km/h. The simulators shall use the classical model for Rayleigh fading and there shall be no correlation between the two simulators. The difference in contribution to the signal strength from the signal generators shall be 1 dB, (the higher signal shall come from signal generator A);

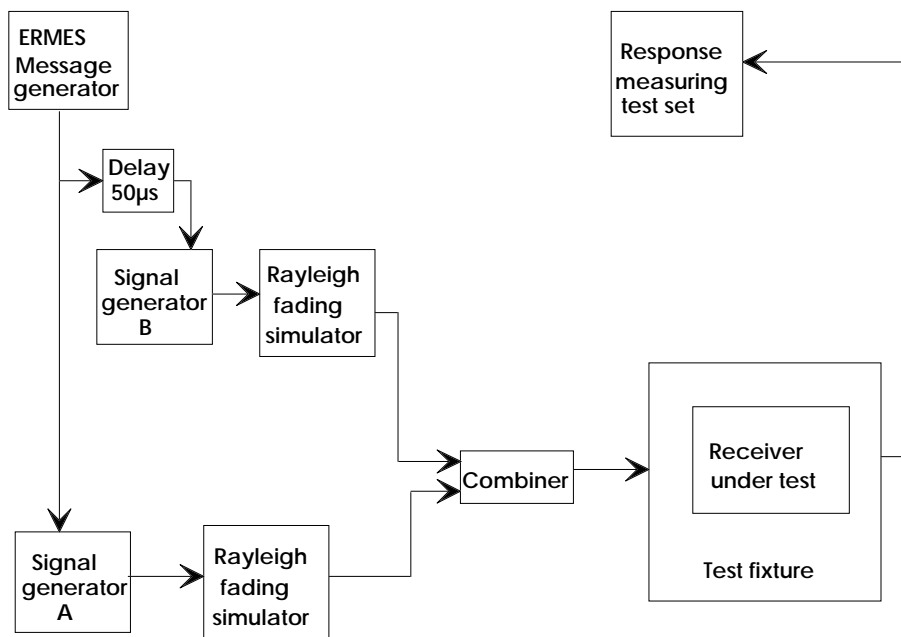

Figure A.3: Measurement set-up

The test fixture shall meet the requirements of annex B, subclause B.6.

The delay between the two signals shall be 50 μ s.

- b) the method of measurement of measured usable sensitivity for messages specified in annex A, clause A.1 steps b) through e), shall then be used with the exception that 50 values instead of 10 shall be recorded;
- c) the sensitivity figure shall be recorded as the ratio in dB of the value recorded in step b) above and the reference figure (see annex B, clause B.3).

Annex B (normative): Ancillary test data

B.1 Simulated man

The simulated (sometimes known as "salty") man comprises a rotatable acrylic tube filled with salt water placed on the ground.

The container shall have the dimensions shown in table B.1.

Table B.1

Dimension	Value
Height	1,7 ± 0,1 m;
Inside diameter	300 ± 5 mm;
Side wall thickness	5 ± 0,5 mm.

The container shall be filled with a salt (NaCl) solution of 1,5 g per litre of distilled water.

The equipment shall be fixed to the surface of the simulated man, at the appropriate height for the equipment.

B.2 Definition of un-wanted test signal

The un-wanted signal shall be a carrier frequency modulated by a 400 Hz sinusoidal signal with a deviation of ± 3 kHz. The centre frequency and amplitude of this un-wanted test signal shall be as specified in the respective test.

B.3 Definition of reference figure

The reference figure is used as the basis for measurements in the appropriate test fixture. It is established according to the following procedure:

- the average usable sensitivity under normal conditions as measured in annex A, clause A.1, shall be noted;
- the difference between the value determined in a) above and the figure given in subclause 7.1 a) shall be noted;
- the receiver shall be placed into the test fixture (see figure B.1 and clause B.6) oriented as specified by the manufacturer;
- the input signal level to the test fixture required to produce a message acceptance ratio of 80 % shall be determined according to the procedure described in annex A, subclause A.1.2, steps b) to e), and shall be noted in dB μ V p.d. (potential difference);
- the reference figure for this test fixture is then the value noted for step d), increased by the sum of the value noted for step b) and +3 dB.

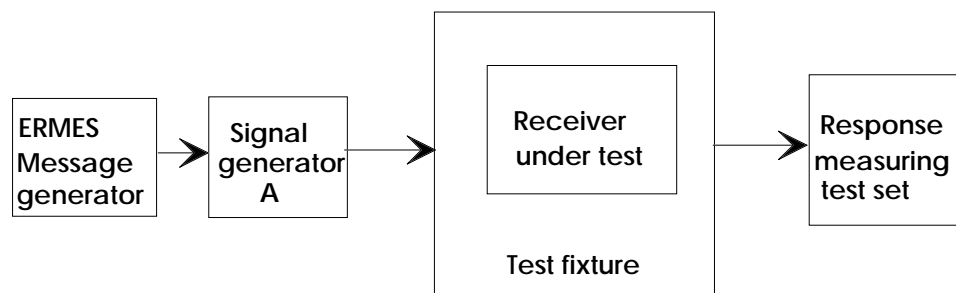

Figure B.1: Receiver in test fixture

B.4 Sensitivity measurement test sites

B.4.1 Description of test sites for receiver sensitivity measurements

One of the test sites described in this clause shall be used to perform the measurements described in annex A, clause A.1 over the ERMES frequency range. The test site shall be calibrated.

B.4.2 Description of an open air test site

B.4.2.1 Receiver sensitivity measurement test site characteristics

Parameter	Limits
Useful frequency range:	25 MHz to 1 000 MHz
Nominal site attenuation, 30 m range:	20 dB to 46 dB for 25 MHz 36 dB to 62 dB for 169,5 MHz 52 dB to 78 dB for 1 000 MHz
NOTE:	The nominal attenuation of the 30 m test site for a half-wave dipole is 26 dB for 25 MHz, 42 dB for 169,5 MHz and 58 dB for 1 000 MHz. The actual attenuation may vary due to ground reflections.

B.4.2.2 Receiver sensitivity measurement test site

The receiver sensitivity measurement test site shall be on level ground with uniform electrical characteristics and be free from reflecting objects over as wide an area as possible to ensure that extraneous electromagnetic fields do not affect the accuracy of the test results.

The minimum boundary of the test site shall be an ellipse having a 60 m major axis and a 52 m minor axis. The equipment under test and the transmitting antenna shall be located at the foci. Half of the ellipse in the front half of a transmitting antenna is sufficient if the transmitting antenna is highly directional, as, for example, a corner reflector antenna.

No extraneous conducting objects having any dimension in excess of 15 cm for measurements over the frequency range of 25 MHz to 300 MHz, or 5 cm for measurements over the frequency range of 300 MHz to 1 GHz, shall be in the immediate vicinity of the equipment under test or of the main transmitting lobe of the transmitting antenna.

The suitability of a test range for this purpose may be tested (without the simulated man) by:

- a) measuring the field strength at the normal test position. The frequency and field strength used in this measurement shall be the same as that used in subclause B.4.2.5;
- b) measuring the field strength 50 cm in front of the normal test position (i.e. towards the transmitter);
- c) measuring the field strength 50 cm behind the normal test position (i.e. away from the transmitter);
- d) measuring the field strength to the left of the normal position; and
- e) measuring the field strength to the right of the normal position.

The measurements shall all be made at the nominal measurement height.

A suitable test range is defined as having reflections at least 20 dB below the nominal signal strength, therefore the measurements in b) and c) should be within $\pm 1,0$ dB of the measurement in step a), and each of the measurements in steps d) and e) should be within $\pm 1,2$ dB of the measurement in step a).

The distance between the vertical axis through the centre of the antenna of the equipment under test and the vertical axis through the centre of the transmitting antenna shall be at least 30 m.

B.4.2.3 Position of the equipment under test

Considering figure B.2, the receiver under test shall be placed on the "simulated man", see clause B.1, at 1,0 m \pm 0,1 m above ground level and oriented so that a face, specified by the manufacturer, is normal to the direction of the test antenna. The simulated man shall be placed on the ground with no intervening conductive ground plane. This is the reference orientation for the measurement. The response measuring test set shall be as declared by the manufacturer for the test. This may be the display of the receiver under test or may include a non-conductive acoustic tube suitable for transmitting an audible response tone from the receiver to a microphone and recording equipment.

B.4.2.4 Transmitting antenna

The transmitting antenna shall be suitable for the transmission of linearly polarised waves. It may consist of a half-wave dipole, the length of which is adjusted for the frequency concerned. However, for practical reasons, or to increase the sensitivity of the measurements, it may be convenient to use a directional antenna such as a corner reflector.

The transmitting antenna shall be mounted at a height of between 1 m and 4 m above ground, (see figure B.2).

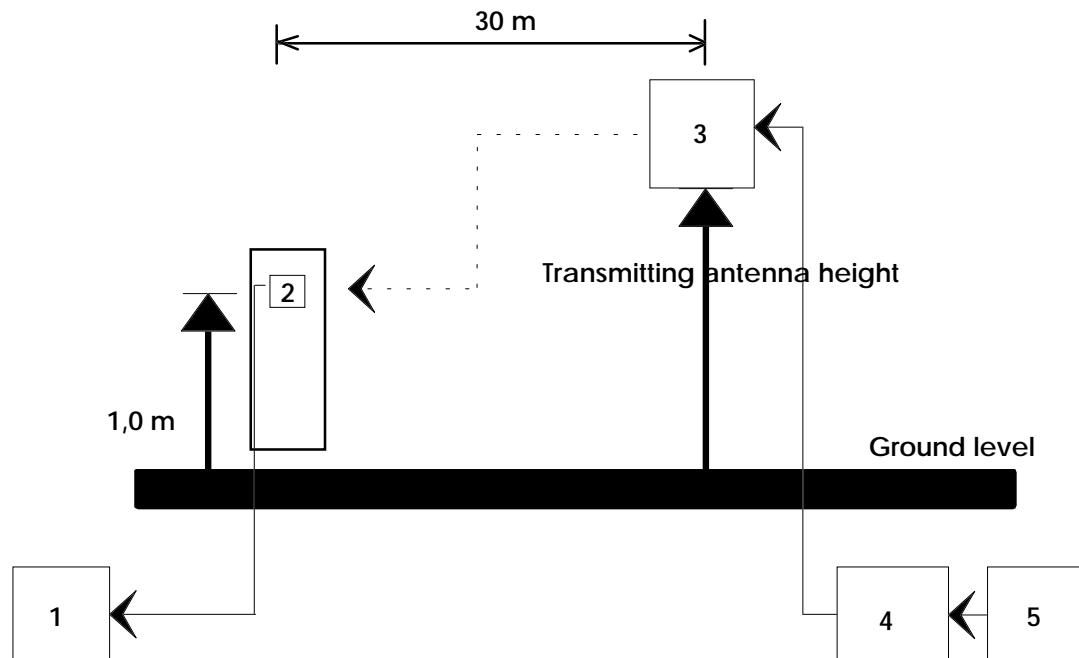

- 1) Response measuring test set.
- 2) Receiver under test.
- 3) Transmitting antenna.
- 4) Signal generator.
- 5) Message generator.

Figure B.2: Measurement arrangement for testing receiver sensitivity

B.4.2.5 Calibration

Considering figure B.3, all equipment shall be adjusted to the frequency at which the calibration is to be measured. The transmitting antenna and the substitution antenna (see subclause B.4.2.6) shall be vertically polarised. The substitution antenna connected to the selective measuring device constitutes a calibrated field strength meter:

- a) the signal generator shall be adjusted to produce the required field strength at the substitution antenna;

- b) the nominal height of the transmitting antenna is $3,0 \text{ m} \pm 0,2 \text{ m}$. This shall be adjusted in order to achieve a maximum signal on the selective measuring device. If no maximum is found, then the nominal height shall be used;
- c) the signal generator level and the selective measuring device reading shall be noted, therefore, establishing a relationship between the signal generator level and the field strength at the substitution antenna;
- d) the frequency used for the calibration and for the measurement shall be monitored to ensure that the measurement is free from interfering signals.

B.4.2.6 Substitution antenna

The substitution antenna replaces the equipment under test during part of the measurement. The substitution antenna shall be a calibrated half-wave dipole and shall be arranged so that the centre of the substitution antenna shall coincide with the normal position of the centre of the equipment under test as shown in figure B.3.

The substitution antenna (2) shall be mounted at the end of a horizontal boom. The mounting shall permit the antenna to be positioned for measuring the vertical component of the electric field. The lower end of the antenna, when oriented for vertical polarisation and placed in the proper position, shall be at least 0,3 m above the ground.

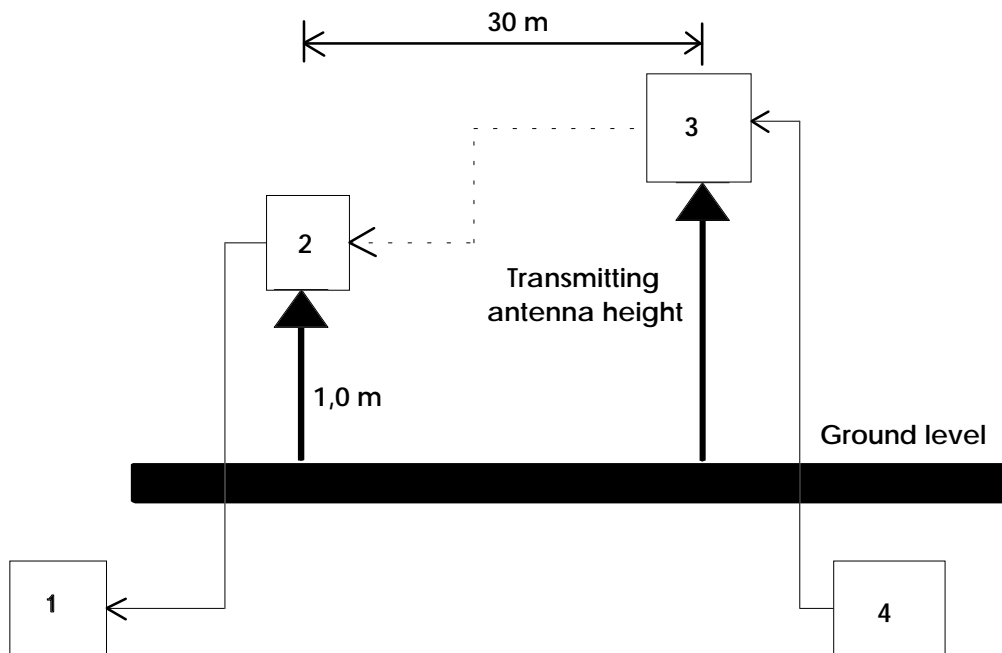

- 1) Selective measuring device.
- 2) Substitution antenna.
- 3) Transmitting antenna.
- 4) Signal generator

Figure B.3: Measurement arrangement for calibration of open air test site

The cable from the substitution antenna shall be routed along the horizontal boom for at least 1 m, and should preferably extend, while being at ground level, at least 3 m beyond the minimum boundary of the test site before it is connected to the selective measuring device (1). Alternatively, the cable may be routed underground.

B.4.2.7 Selective measuring device

The selective measuring device may be either a frequency selective voltmeter, a spectrum analyser, or a calibrated field-strength meter, and shall be placed, together with its associated input cable, in a position such that it shall not affect the accuracy of the test results.

B.4.3 Description of an anechoic chamber

An anechoic chamber as described in annex B, subclause B.5.1 may be used as a test site.

B.5 Definition of test sites suitable for spurious emissions measurements

B.5.1 An anechoic chamber

B.5.1.1 General

An anechoic chamber is a chamber covered inside with radio frequency absorbing material and simulating a free space environment. In addition the chamber may be shielded, in which case an environment free from interfering signals is provided. It is an alternative site on which to perform the measurements, using the radiated measurement methods described in annex A, clause A.2 of this TBR, in the frequency range over which it can be calibrated. Absolute measurements require a calibration of the anechoic chamber. The test antenna, equipment under test and substitution antenna are used in a way similar to that at the open air test site, but are all located at the same fixed height above the floor.

When used for receiver sensitivity measurements it should be noted that:

- a) the whole-body resonant frequency of the simulated man may be different in a free space environment of an anechoic chamber as compared with an open air test site;
- b) the electric and magnetic field profiles on the simulated man may be different in the free space environment of an anechoic chamber as compared with an open air test site.

Therefore, a careful calibration of the anechoic chamber is necessary, and a correlation to an open air site measurement with respect to the 30 m open air site described in subclause B.4.2 should be considered before an anechoic chamber can be used as a test site for sensitivity measurements with a simulated man.

B.5.1.2 Description

An anechoic chamber shall meet the requirements for shielding loss and wall return loss as shown in figure B.4. Figure B.5 shows an example of the construction of an anechoic chamber having a base area of 5 m by 10 m and a height of 5 m.

The ceiling and walls shall be coated with pyramidal absorbers approximately 1 m long. The base shall be covered with special absorbers which form the floor. The available internal dimensions of the chamber shall be 3 m x 8 m x 3 m, so that a maximum measuring distance of 5 m in the middle axis of this chamber is available. The floor absorbers reject floor reflections so that the antenna height need not be changed unless explicitly specified for the measurements. Anechoic chambers of other dimensions may be used.

Figure B.4 shows the attenuation requirements for the shielding loss required to ensure that interfering signals will be kept to a low level. In certain situations different levels of shielding loss may be satisfactory. The limits given on return loss should be maintained to ensure satisfactory operation of the anechoic chamber.

B.5.1.3 Influence of parasitic reflections

For free-space propagation in the far field, the relationship of the field strength X and the distance R is given by $X = X_0 \times (R_0/R)$, where X_0 is the reference field strength and R_0 is the reference distance. This relationship allows relative measurements to be made as all constants are eliminated within the ratio and neither cable attenuation, antenna mismatch nor antenna dimensions are of importance.

If the logarithm of the above equations is used, the deviation from the ideal curve can be easily seen because the ideal correlation of field strength and distance appears as a straight line. The deviations occurring in practice are then clearly visible. This indirect method shows quickly and easily any disturbances due to reflections and is far less difficult than the direct measurement of reflection attenuation.

With an anechoic chamber of the dimensions given above, at low frequencies below 100 MHz, there are no far field conditions, but the wall reflections are stronger, so that careful calibration is necessary. In the medium frequency range, from 100 MHz to 1 GHz, the dependence of the field strength to the distance meets the expectations very well. Above 1 GHz, because more reflections will occur, the dependence of the field strength to the distance will not correlate so closely.

B.5.1.4 Calibration and mode of use

The calibration and mode of use is the same as for an open air test site, the only difference being that the test antenna does not need to be raised and lowered whilst searching for a maximum, which simplifies the method of measurement.

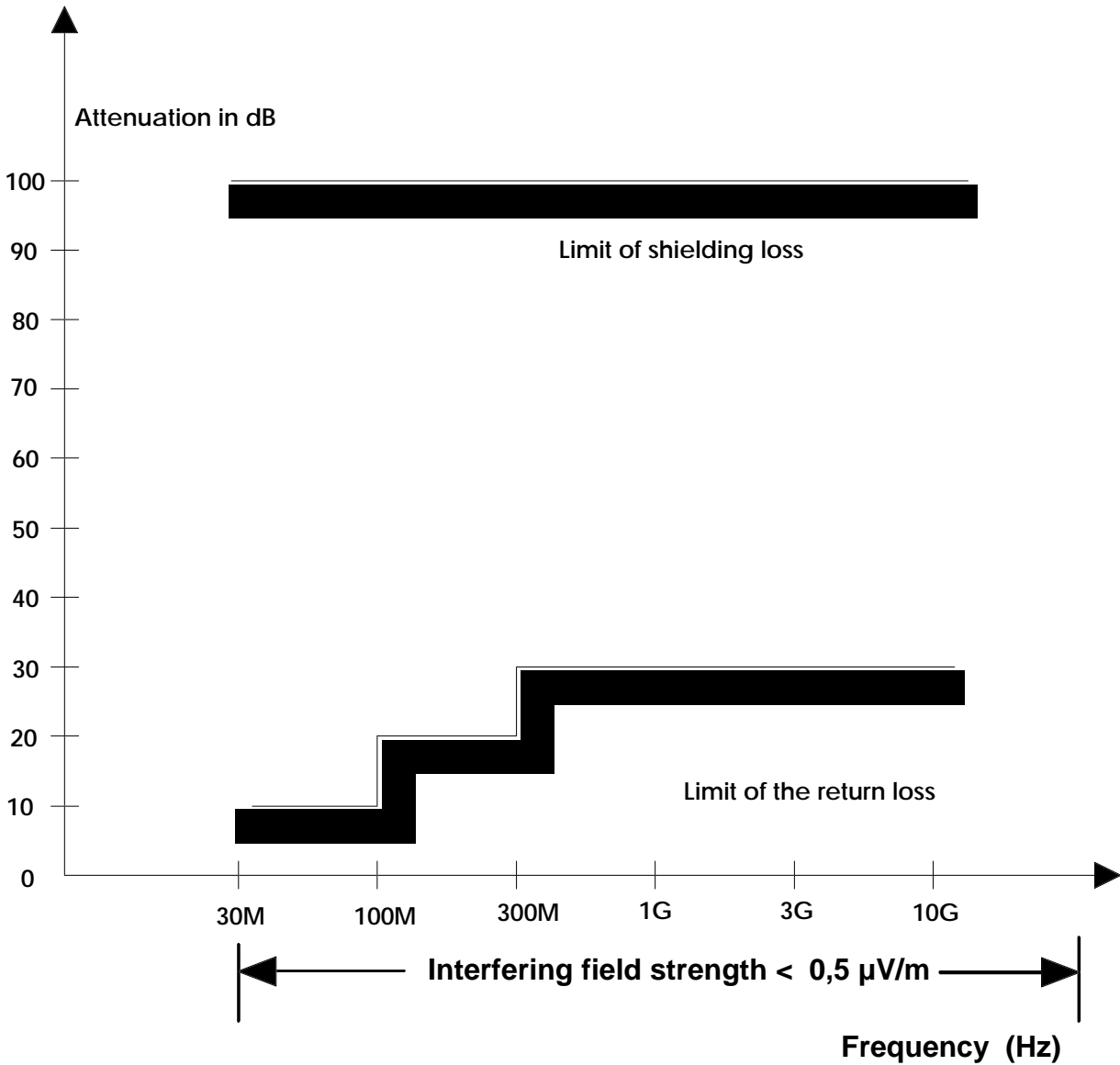

Figure B.4

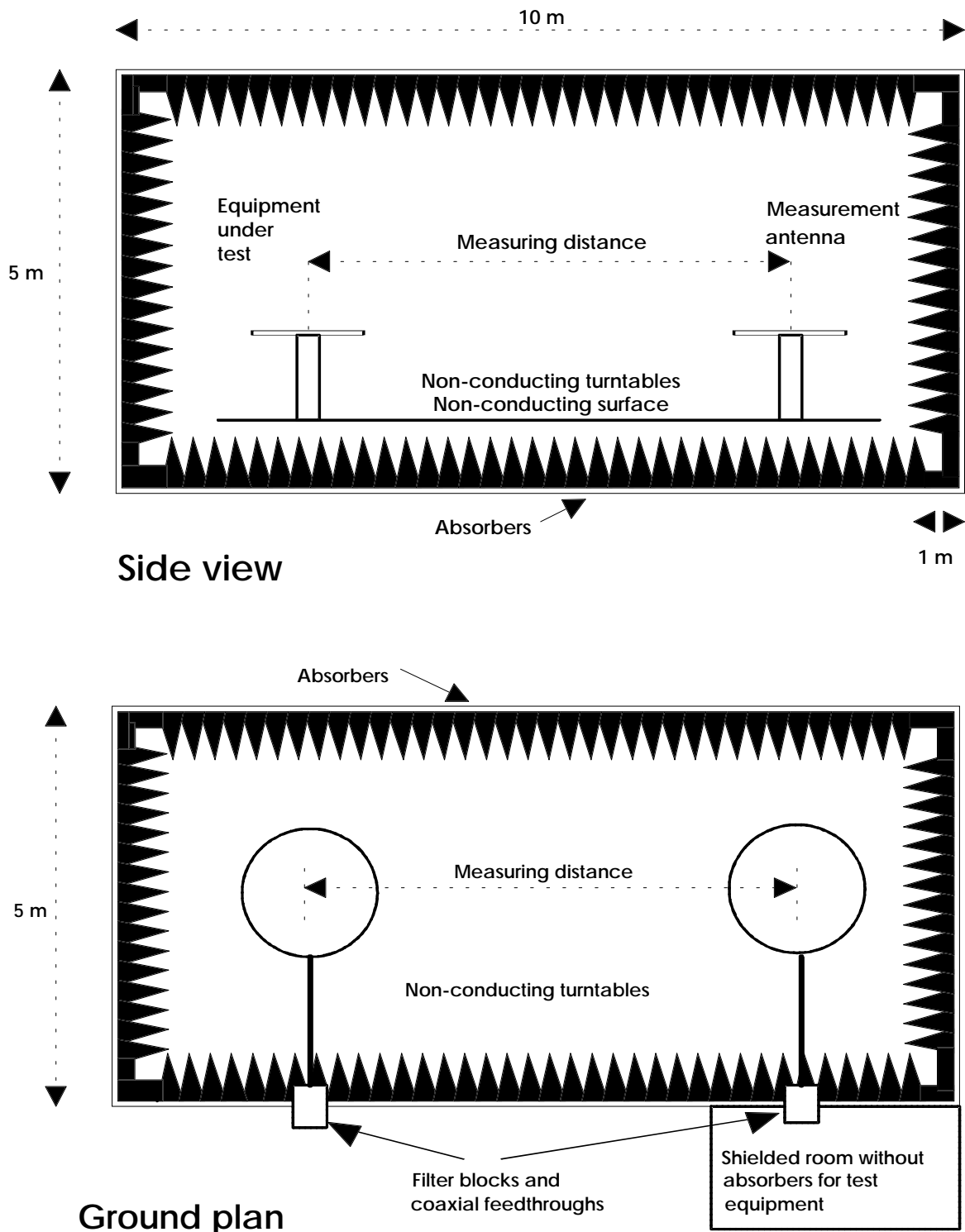

Figure B.5

B.5.2 Open air test site suitable for emission tests

A 3 m radiated emissions open air test site may be used to perform the measurements described in annex A, clause A.2 of this TBR, over the usable frequency range of the test site. The test site shall be calibrated at all measurement frequencies.

B.5.2.1 Test site characteristics for radiated emissions testing

Table B.3

Parameter	Limits
Useful frequency range:	30 MHz to 4 000 MHz;
Radiation angle limits:	+ 40° to - 10°.

Antennas for use at or above 1 000 MHz shall be calibrated at the measuring distance at which it will be used.

B.5.2.2 Radiation emissions test site

The 3 m test site described in this TBR provides consistent results regardless of time or location. It permits an accuracy over the useful frequency range comparable to that achievable on larger test sites, while requiring less sensitive instrumentation than on these larger sites.

The radiation test site shall be on level ground having uniform electrical characteristics and be free from reflecting objects over as wide an area as possible, to ensure that extraneous electromagnetic fields do not affect the accuracy of the test results.

A continuous ground screen (either sheet metal or wire mesh having openings no greater than 1 cm, which should maintain good electrical contact between the wires) shall be used to establish a uniformly conducting earth over part of the test site. The minimum ground screen area is shown in figure B.6.

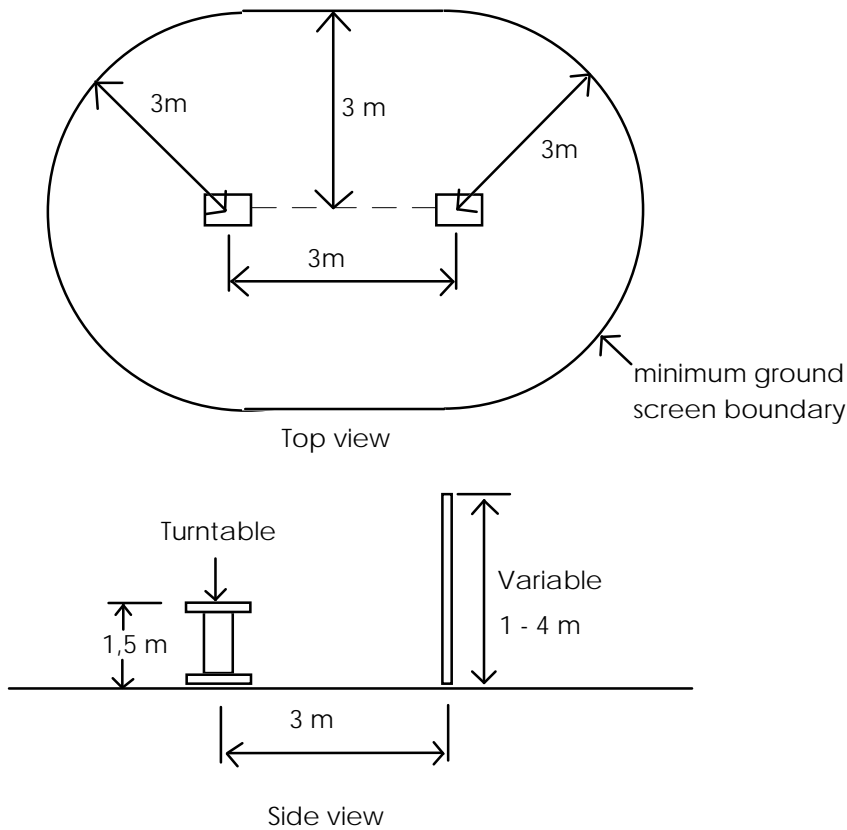

Figure B.6: 3 m site dimensions inside the ground screen boundaries

No extraneous conducting objects having any dimensions in excess of 5 cm should be present within the minimum ground screen boundary. Objects between the minimum ground screen boundary and the test site boundary shall not be such as to affect the test results.

The test site shall have a turntable and a support for the measuring antenna. The distance in the horizontal plane between the vertical axis through the centre of the turntable and the vertical axis through

the centre of measuring antenna mounted on its support shall be 3 m. A shelter may be provided for all or part of the test site. All such construction, except for nails, hinges, etc., having no dimension greater than 5 cm, shall be of wood, plastic, or other non-conducting material. Any wood shall be impregnated to ensure minimum water absorption.

All test equipment located above ground shall preferably be powered by batteries. If the equipment is powered from the mains, each of the mains supply cables shall be provided with a suitable radio-frequency filter. The cable connecting the filter and the measuring equipment shall be screened and shall be as short as possible. The cable connecting the filter and the supply mains shall be either screened and be at ground level, or shall be buried to a depth of approximately 30 cm.

B.5.2.3 Position of the equipment under test

The equipment in its cabinet or housing in which it normally operates shall be placed on a horizontal platform, the upper side of which is 1,5 m above the ground. The platform and its support shall be made of non-conducting material.

For equipment having an integral antenna, place the equipment on the platform in a position which is closest to its position in normal use.

For equipment having a rigid external integral antenna, the equipment shall be mounted so that the antenna is in a vertical position.

For equipment having a non-rigid external integral antenna, the antenna, shall be mounted vertically with a non-conducting support.

It shall be possible to rotate the equipment about the vertical axis through the centre of the antenna of the equipment under test. It is recommended that a platform in the form of a turntable, preferably remotely controlled, should be used for this purpose.

If the equipment has a power cable, it should extend down to the turntable, and any excess cable length should be coiled on the turntable.

B.5.2.4 Measuring antenna support

The measuring antenna support shall consist of a horizontal boom supported by a vertical pole, both being made of non-conducting material. The boom shall project at least 1 m from the vertical pole in the direction of the equipment under test and shall be arranged so that it may be raised and lowered from 1 m to 4 m.

B.5.2.5 Measuring antenna

The measuring antenna shall be suitable for the reception of linearly polarised waves. It may consist of a half-wave dipole, the length of which is adjusted for the frequency concerned. For practical reasons, however, or to increase the sensitivity of the measurements, it may be convenient to use a number of separate fixed broad band dipoles or more complex antennas.

The measuring antenna shall be mounted at the end of the horizontal boom. The mounting shall permit the antenna to be positioned for measuring both the horizontal and the vertical components of the electrical field. The lower end of the antenna, when oriented for vertical polarisation and placed in its lowest position, shall be at least 0,3 m above the ground.

The cable from the antenna shall be routed along the horizontal boom for at least 3 m and should preferably extend, while being at ground level, at least 3 m beyond the minimum boundary of the test site before it is connected to the selective measuring device. Alternatively, the cable may be routed underground.

B.5.2.6 Substitution antenna

The substitution antenna replaces the equipment under test during part of the measurement. The substitution antenna shall be a calibrated half-wave dipole and shall be arranged in a manner so that the

centre of the substitution antenna shall coincide with the normal position of the centre of the equipment under test.

B.5.2.7 Radio-frequency signal generator

A well-shielded radio-frequency signal generator, with a matching or combining network (if required) and its associated output cable, shall be placed in a position such that it will not affect the accuracy of the test results, and shall be connected to and matched to the substitution antenna.

B.5.2.8 Selective measuring device

The selective measuring device may be either a frequency selective voltmeter, a spectrum analyser, or a calibrated field-strength meter, and shall be placed, together with its associated input cable, in a position such that it shall not affect the accuracy of the test results.

B.6 Description of test fixture

It is useful to have available a test fixture so that measurements involving high signal levels, measurements requiring relative measurements, and measurements under extreme conditions can be readily carried out.

The test fixture shall be a radio frequency coupling device associated with an integral antenna equipment for coupling the integral antenna to a 50 Ω radio frequency terminal at the working frequencies of the equipment under test. This allows certain measurements to be performed using the conducted measurement methods. Measurements may only be performed at or near frequencies for which the test fixture has been calibrated. This calibration may be achieved by the determination of the reference figure as described in clause B.3.

In addition, the test fixture may provide:

- 1) a connection to an external power supply; and
- 2) interfaces to other relevant inputs and outputs.

The test fixture shall normally be provided by the applicant.

The performance characteristics of the test fixture shall be approved by the test laboratory and shall conform to the following basic parameters:

- a) circuitry associated with the RF coupling shall contain no active or non linear devices;
- b) the Voltage Standing Wave Ratio (VSWR) at the 50 Ω socket shall not be greater than 1,5 over the frequency range of the measurements;
- c) the coupling loss shall be substantially independent of the position of the test fixture and be substantially unaffected by the proximity of surrounding objects or people. The coupling loss shall be reproducible when the equipment under test is removed and replaced;
- d) the coupling loss shall remain substantially constant when the environmental conditions are varied.

B.7 Measurement uncertainty

The measurement uncertainty should be evaluated according to the methodology described in ETR 028 [9] when applicable.

The maximum values of measurement uncertainty shown in table B.4 associated with each measurement parameter apply to all of the test cases described in this TBR:

Parameter	Limit
Absolute radio frequency	$\pm 0,1$ ppm;
Bit Rate (average)	± 1 ppm;
Temperature	$\pm 2^{\circ}\text{C}$;
Length	$\pm 0,4$ %;
Relative Humidity	± 5 %.

The accumulated measurement uncertainties of the test system in use for the parameters to be measured should not exceed those given in table B.5. This is in order to ensure that the measurements remain within an acceptable quality.

Table B.5: Recommended maximum acceptable uncertainties

Measurement parameter	Maximum acceptable uncertainty
Sensitivity	± 3 dB
Two-signal measurement (stop band)	± 4 dB
Three signal measurement	± 3 dB
Radiated emissions of receivers	± 6 dB

NOTE: The uncertainty figures are valid for a confidence level of 95 %.

B.8 Maximum degradation in required sensitivity

The maximum degradation in required sensitivity is derived as follows:

- a) the reference figure (see clause B.3) is determined in a suitable test fixture (see clause B.6). Subtract 3 dB from this reference figure and note the result in dB μ V;
- b) the sensitivity is measured as in clause B.3 c) and d) under the required conditions, as described in the test, in the same test fixture and the results are noted in dB μ V;
- c) for all the results noted in b), when the figure noted in b) is more than the figure noted in a), record the difference in dB;
- d) the largest value noted in c) is defined as the maximum degradation in required sensitivity.

B.9 Differential factors

B.9.1 General

The usual presentation of a message today is a Liquid Crystal Display (LCD) integrated into the receiver and the usual alert function is an audible sound. During testing on a test site or in a test fixture, it would be much quicker if, instead of having to check the quality of the presented message, the tester could determine whether an audible alert has or has not been generated. Another speed advantage of the checking for an alert is that the receiver would not have to be moved in the test fixture. A further benefit, when testing at temperature extremes, is that the environmental chamber would not have to be opened to examine the message. This is especially critical at temperatures below 0°C, when it would be very difficult to avoid moisture condensing inside the chamber and on parts of the receiver.

If the signal level differential between the message presentation and the alert is determined and if tests are carried out using a suitable alert, then it is possible to calculate the signal level required for the message presentation by adding together the measurement obtained from the test using the alert and the differential previously obtained.

B.9.2 Definition of numeric differential factor

The numeric differential factor is the difference between the signal level required for a receiver to recover a successful tone-only message and the signal level required to recover a successful numeric message (see subclause 5.6). It is established according to the following procedure:

- a) the receiver shall be placed into the test fixture (see clause B.6) oriented as specified by the manufacturer;

- b) a test paging signal consisting of a tone-only message (as described in subclause 8.12.1) shall be applied to the input of the test fixture;
- c) the input signal level to the test fixture required to produce a message acceptance ratio of 80 % shall be determined according to the procedure described in annex A, subclause A.1.2, steps b) to e). The result shall be recorded in dB μ V;
- d) repeat step c), except that the test paging signal shall consist of a 10 character numeric message as described in subclause 5.6 and the acceptance of a successful numeric message shall be in accordance with the definition in subclause 5.6.2. The result shall be recorded in dB μ V;
- e) the numeric differential factor is defined as the difference between the result recorded in d) minus the result recorded in c), expressed in dB.

B.9.3 Definition of alphanumeric differential factor

The alphanumeric differential factor is the difference between the signal level required for a receiver to recover a successful tone-only message and the signal level required to recover a successful alphanumeric message (see annex A, subclause A.1.1). It is established according to the following procedure:

- a) the receiver shall be placed into the test fixture (see clause B.6) oriented as specified by the manufacturer;
- b) a test paging signal consisting of a tone-only message (as described in subclause 8.12.1) shall be applied to the input of the test fixture;
- c) the input signal level to the test fixture required to produce a message acceptance ratio of 80 % shall be determined according to the procedure described in annex A, subclause A.1.2, steps b) to e). The result shall be recorded in dB μ V;
- d) repeat step c), except that the test paging signal shall consist of a 55 character alphanumeric message as described in annex A, subclause A.1.1 and the acceptance of a successful alphanumeric message shall be in accordance with the definition in annex A, subclause A.1.1. The result shall be recorded in dB μ V;
- e) the alphanumeric differential factor is defined as the difference between the result recorded in d) minus the result recorded in c), expressed in dB.

B.10 Calculations of spurious responses frequencies

B.10.1 Introduction to the method

To determine the frequencies at which spurious responses may occur the following calculations shall be made:

- a) calculation of the "limited frequency range":
 - the limited frequency range is equal to the frequency of the local oscillator signal (f_{lo}) applied to the 1st. mixer of the receiver \pm the sum of the intermediate frequencies (if_1, \dots, if_n) and half the switching range of the receiver ($sr/2$);
 - hence the limited frequency range = $f_{lo} \pm (if_1 + if_2 + \dots + if_n + sr/2)$;
- b) calculation of frequencies outside the limited frequency range:
 - a calculation of the frequencies at which spurious responses may occur outside the range determined in a) shall be made for the remaining frequency range of interest:
 - the frequencies outside the limited frequency range are equal to the harmonics of the frequency of the local oscillator signal (f_{lo}) applied to the 1st mixer of the receiver \pm the numeric value of the 1st. intermediate frequency (if_1) of the receiver;
 - hence the frequencies of these spurious responses = $nf_{lo} \pm if_1$ where n is an integer greater than or equal to 2.

For the calculations a) and b) the manufacturer shall state the frequency of the receiver, the frequency of the local oscillator signal (f_{lo}) applied to the 1st mixer of the receiver, the intermediate frequencies (if_1, if_2 etc.) and the switching range of the receiver.

NOTE: The switching range of the receiver is defined as the maximum frequency range over which the receiver can be operated without re-alignment or re-programming.

Annex C (normative): Character sets in the ERMES system

C.1 Characters for numeric paging

Numerical messages are coded with 4 bits per character. A numeric or alphanumeric receiver shall be capable of presenting the characters given in table C.1.

Table C.1

b4	b3	b2	b1	Character
0	0	0	0	0
0	0	0	1	1
0	0	1	0	2
0	0	1	1	3
0	1	0	0	4
0	1	0	1	5
0	1	1	0	6
0	1	1	1	7
1	0	0	0	8
1	0	0	1	9
1	0	1	0	/
1	0	1	1	(space)
1	1	0	0	U
1	1	0	1	- (hyphen)
1	1	1	0	.(full stop)
1	1	1	1	%

NOTE: The characters of this set, when displayed, should approximate to the appearance of the relevant characters specified in ISO standard 1073 Parts 1 and 2 [4]. For a simple seven segment display the symbols "/", "." and "%" should be represented as shown in table C.2. Better representations of these characters may be used.

Table C.2

b4	b3	b2	b1	Character	Representation
1	0	1	0	/	
1	1	1	0	.(full stop)	
1	1	1	1	%	

C.2 Characters for alphanumeric paging

Alphanumeric characters shall be coded with 7 bits per character.

All alphanumeric receivers shall use the character set given in table C.3.

NOTE: This character set is the basic ERMES character set with the character set number "00000".

Table C.3

				b7	0	0	0	0	1	1	1	1
				b6	0	0	1	1	0	0	1	1
				b5	0	1	0	1	0	1	0	1
b4	b3	b2	b1		0	1	2	3	4	5	6	7
0	0	0	0	0	@	Δ	SP	0	i	P	ı	p
0	0	0	1	1	£	DC1	!	1	A	Q	a	q
0	0	1	0	2	\$	Φ	"	2	B	R	b	r
0	0	1	1	3	¥	Γ	#	3	C	S	c	s
0	1	0	0	4	è	Λ	α	4	D	T	d	t
0	1	0	1	5	é	Ω	%	5	E	U	e	u
0	1	1	0	6	ù	Π	&	6	F	V	f	v
0	1	1	1	7	ì	Ψ	'	7	G	W	g	w
1	0	0	0	8	ò	Σ	(8	H	X	h	x
1	0	0	1	9	ç	θ)	9	I	Y	i	y
1	0	1	0	10	LF	Ξ	*	:	J	Z	j	z
1	0	1	1	11	Ø	ESC	+	;	K	Ä	k	ä
1	1	0	0	12	ø	Æ	,	<	L	Ö	l	ö
1	1	0	1	13	CR	æ	-	=	M	Ñ	m	ñ
1	1	1	0	14	Á	ß	.	>	N	Ü	n	ü
1	1	1	1	15	á	É	/	?	O	Ş	o	à

NOTE 1: DC1 shall be used only as the End of Message (EOM) character.

NOTE 2: The characters of this set, when presented, should approximate to the appearance of the relevant characters specified in ISO standard 1073 [4] and the corresponding national standards.

History

Document history	
November 1994	First Edition
April 1996	Public Enquiry PE 105: 1996-04-08 to 1996-08-30