



**T**ECHNICAL  
**B**ASIS for  
**R**EGULATION

**DRAFT**  
pr **TBR 006**  
September 1995  
Second Edition

---

Source: ETSI TC-RES

Reference: RTBR/RES-03051

ICS: 30.060.50

**Key words:** DECT, test specification, radio

**Radio Equipment and Systems (RES);  
Digital European Cordless Telecommunications (DECT);  
General terminal attachment requirements**

**ETSI**

European Telecommunications Standards Institute

**ETSI Secretariat**

**Postal address:** F-06921 Sophia Antipolis CEDEX - FRANCE

**Office address:** 650 Route des Lucioles - Sophia Antipolis - Valbonne - FRANCE

**X.400:** c=fr, a=atlas, p=etsi, s=secretariat - **Internet:** secretariat@etsi.fr

Tel.: +33 92 94 42 00 - Fax: +33 93 65 47 16

---

**Copyright Notification:** No part may be reproduced except as authorized by written permission. The copyright and the foregoing restriction extend to reproduction in all media.

© European Telecommunications Standards Institute 1995. All rights reserved.





	5.6.1.1	Calibration of the test fixture for the measurement of transmitter characteristics .....	26
	5.6.1.2	Calibration of the test fixture for the measurement of receiver characteristics .....	26
	5.6.1.3	Mode of use .....	27
	5.6.2	Equipment with a temporary or internal permanent antenna connector .....	27
	5.6.2.1	Equipment with a temporary antenna connector .....	27
5.7		Indoor test site .....	28
	5.7.1	Description .....	28
	5.7.2	Test for parasitic reflections .....	28
	5.7.3	Calibration and mode of use .....	29
5.8		Lower Tester (LT) .....	29
	5.8.1	Description .....	29
	5.8.2	Connections between the EUT and the LT .....	29
	5.8.3	Functions and abilities .....	30
	5.8.4	Signal generation uncertainty .....	30
	5.8.4.1	Modulated DECT-like carrier .....	30
	5.8.4.2	CW interferers .....	30
	5.8.4.3	DECT RF Signal .....	30
	5.8.4.4	Test modulation signals .....	30
	5.8.5	Measurement uncertainty .....	30
	5.8.5.1	RF measurements .....	31
5.9		Upper Tester (UT) .....	31
	5.9.1	Description of the UT .....	31
	5.9.2	The test standby mode .....	31
	5.9.3	Test messages .....	31
5.10		Description of the lower tester FT and PT .....	32
5.11		General test methods .....	32
	5.11.1	General .....	32
	5.11.2	Sampling the RF signal .....	32
	5.11.2.1	Introduction .....	32
	5.11.2.2	Sampling method .....	32
	5.11.3	Determining the reference position .....	33
	5.11.3.1	Case 1: EUTs that cannot transmit .....	33
	5.11.3.2	Case 2: EUTs that can transmit .....	33
	5.11.4	Bit Error Rate (BER) measurements .....	33
5.12		Test set-up .....	33
	5.12.1	Test set-up 1 .....	33
	5.12.2	Test set-up 2 .....	34
	5.12.3	Test set-up 3 .....	34
	5.12.4	Test set-up 4 .....	35
	5.12.5	Test set-up 5 .....	35
5.13		Test arrangements for intermodulation measurements .....	36
	5.13.1	PT to PT arrangement .....	36
5.13.2		FT to FT arrangement .....	36
5.13.3		FT to PT arrangement .....	37
6		Test conditions, power sources and ambient temperatures .....	37
	6.1	General .....	37
	6.2	Nominal test conditions .....	38
	6.3	Extreme test conditions .....	38
	6.4	Test power source - general requirements .....	39
	6.5	Nominal test power source .....	39
	6.5.1	Mains voltage .....	39
	6.5.2	Regulated lead acid battery power sources .....	40
	6.5.3	Nickel cadmium battery .....	40
	6.5.4	Other power sources .....	40
	6.6	Extreme test power source .....	40
	6.6.1	Mains voltage .....	40
	6.6.2	Regulated lead acid battery power sources .....	40

	6.6.3	Nickel cadmium battery.....	40
	6.6.4	Other power sources.....	40
6.7		Testing of host connected equipment and plug-in cards.....	40
	6.7.1	Alternative A: composite equipment.....	41
	6.7.2	Alternative B: use of a test jig and three hosts.....	41
7		Accuracy and stability of RF carriers.....	41
	7.1	Definition.....	41
	7.2	Test environment.....	41
	7.3	Method of measurement.....	42
	7.4	Verdict criteria when the EUT is a RFP.....	42
	7.5	Verdict criteria when the EUT is a PP.....	42
	7.5.1	Case 1: When the measurement is made during the first 1 s of the EUT going into a transmit mode from a non-transmitting mode.....	42
	7.5.2	Case 2: When the measurement is made at any other time.....	42
8		Accuracy and stability of timing parameters.....	43
	8.1	Slot structure definitions.....	43
	8.2	Definition of the position of p0.....	43
	8.3	Measurement of packet timing jitter.....	44
	8.3.1	Test environment.....	44
	8.3.2	Method of measurement.....	44
	8.3.3	Verdict criteria.....	44
	8.4	Measurement of the reference timing accuracy of a RFP.....	44
	8.4.1	Test environment.....	44
	8.4.2	Method of measurement.....	45
	8.4.3	Verdict criteria.....	45
	8.5	Measurement of packet transmission accuracy of a PP.....	45
	8.5.1	Test environment.....	45
	8.5.2	Method of measurement.....	45
	8.5.3	Verdict criteria.....	46
9		Transmission burst.....	46
	9.1	Definitions.....	46
	9.1.1	Physical packets.....	46
	9.1.2	Transmitted power.....	46
	9.1.3	Normal Transmitted Power (NTP).....	46
	9.1.4	Transmitter attack time.....	47
	9.1.5	Transmitter release time.....	47
	9.1.6	Minimum power.....	47
	9.1.7	Maximum power.....	47
	9.1.8	Maintenance of transmission after packet end.....	47
	9.1.9	Transmitter idle power output.....	47
	9.2	Test environment.....	47
	9.3	Method of measurement.....	47
	9.4	Verdict criteria.....	48
10		Transmitted power.....	48
	10.1	Definitions.....	48
	10.1.1	PP and RFP with an integral antenna.....	48
	10.1.2	PP and RFP with external connections for all antennas.....	48
	10.1.3	PP and RFP with both integral and external antennas.....	49
	10.2	PP and RFP with an integral antenna.....	49
	10.2.1	Test environment.....	49
	10.2.2	Method of measurement.....	49
	10.2.3	Verdict criteria for all EUTs.....	50
	10.3	PP and RFP with external antenna connection(s).....	50
	10.3.1	Test environment.....	50
	10.3.2	Method of measurement.....	50
	10.3.3	Verdict criteria for all EUTs.....	50

11	RF carrier modulation .....	50
11.1	Test environment.....	51
11.2	Method of measurement, Parts 1 and 2 .....	51
11.2.1	Part 1.....	51
11.2.2	Part 2.....	51
11.3	Method of measurement, Parts 3 and 4 .....	51
11.3.1	Part 3.....	52
11.3.2	Part 4.....	52
11.4	Verdict criteria for part 1.....	52
11.5	Verdict criteria for part 2.....	52
11.6	Verdict criteria for part 3.....	52
11.7	Verdict criteria for part 4.....	53
12	Unwanted RF power radiation .....	54
12.1	General test conditions .....	54
12.2	Emissions due to modulation .....	54
12.2.1	Definition.....	54
12.2.2	Test environment.....	54
12.2.3	Method of measurement .....	54
12.2.4	Verdict criteria.....	55
12.3	Emissions due to transmitter transients .....	55
12.3.1	Definition.....	55
12.3.2	Test environment.....	55
12.3.3	Method of measurement .....	56
12.3.4	Verdict criteria.....	56
12.4	Emissions due to intermodulation.....	56
12.4.1	Definition.....	57
12.4.2	Test environment.....	57
12.4.3	Method of measurement .....	57
12.4.4	Verdict criteria.....	58
12.5	Spurious emissions when allocated a transmit channel .....	58
12.5.1	Definition.....	58
12.5.2	Radiated emissions .....	58
12.5.2.1	Test environment .....	58
12.5.2.2	Method of measurement.....	58
12.5.2.3	Verdict criteria}.....	59
12.5.3	Conducted spurious emissions.....	60
12.5.3.1	Test environment .....	60
12.5.3.2	Method of measurement.....	60
12.5.3.3	Verdict criteria.....	60
13	Radio receiver testing.....	60
13.1	Radio receiver sensitivity.....	60
13.1.1	Definition.....	60
13.1.2	Test environment.....	60
13.1.3	Method of measurement .....	60
13.1.4	Verdict criteria.....	61
13.2	Radio receiver reference BER.....	61
13.2.1	Definition.....	61
13.2.2	Test environment.....	61
13.2.3	Method of measurement .....	61
13.2.4	Verdict criteria.....	61
13.3	Radio receiver interference performance.....	62
13.3.1	Definition.....	62
13.3.2	Test environment.....	62
13.3.3	Method of measurement .....	62
13.3.4	Verdict criteria.....	63
13.4	Radio receiver blocking case 1: owing to signals occurring at the same time but on other frequencies .....	63
13.4.1	Definition.....	63

	13.4.2	Test environment.....	63
	13.4.3	Method of measurement.....	63
	13.4.4	Verdict criteria .....	64
13.5		Radio receiver blocking case 2: owing to signals occurring at a different time .....	64
	13.5.1	Definition .....	64
	13.5.2	Test environment.....	65
	13.5.3	Method of measurement.....	65
	13.5.4	Verdict criteria .....	65
13.6		Receiver intermodulation performance .....	65
	13.6.1	Definition .....	65
	13.6.2	Test environment.....	65
	13.6.3	Method of measurement.....	66
	13.6.4	Verdict criteria .....	66
13.7		Spurious emissions when the PP has no allocated transmit channel.....	66
	13.7.1	Definition .....	66
	13.7.2	Test environment.....	66
	13.7.3	Method of measurement.....	67
	13.7.4	Verdict criteria (outside the DECT band).....	67
	13.7.5	Verdict criteria (inside the DECT band) .....	67
14		Synchronisation port (FT only).....	67
	14.1	Description .....	67
	14.2	Test environment.....	68
	14.3	FT as the master .....	68
	14.3.1	Method of measurement.....	68
	14.3.2	Verdict criteria .....	68
	14.4	FT as the slave .....	69
	14.4.1	Method of measurement.....	69
	14.4.2	Verdict criteria: Class 1 FTs.....	69
	14.4.3	Verdict criteria: Class 2 FTs.....	69
15		EMC .....	69
16		Equipment identity testing .....	70
	16.1	PP .....	70
	16.2	FP .....	70
17		Efficient use of the radio spectrum.....	70
	17.1	Channel selection .....	70
	17.2	Channel confirmation .....	70
	17.2.1	For the PT .....	70
	17.2.2	For the FT .....	70
	17.3	Channel release .....	71
	17.4	General.....	71
18		Supplement to test procedures in ETS 300 175-3.....	71
	18.1	A field loopback .....	71
	18.1.1	PP under test.....	71
	18.1.2	FP under test.....	71
	18.1.3	General rule.....	71
	18.2	Connectionless service only equipment with transmitters .....	72
	18.3	Speed of test message execution.....	72
	18.4	Allow initial dummy bearer .....	72
	18.5	Editorial.....	72
Annex A (informative):		Bibliography.....	73
Annex B (normative):		Procedures for test fixture calibration and for measurement of radiated spurious emissions.....	74

B.1	Calibration of test fixture for receiver measurements .....	74
B.1.1	Method of measurement .....	74
B.2	Radiated measurements .....	75
B.2.1	General .....	75
B.2.2	Radiated spurious emissions .....	76
B.2.2.1	Definition.....	76
B.2.2.2	Method of measurement .....	76
B.2.3	Cabinet radiation .....	78
B.2.3.1	Definition.....	78
B.2.3.2	Method of measurement .....	78
Annex C (informative):	Essential requirement justification .....	79
Annex D (normative):	Test Support Profile (TSP).....	80
D.1	Introduction .....	80
D.2	Standardised symbols for the status column .....	80
D.3	Capabilities of PP under test .....	81
D.3.1	Services .....	81
D.3.2	Messages.....	81
D.3.3	Message parameters .....	84
D.3.4	Procedure support.....	87
D.3.5	CSF multiplexing functions.....	88
D.3.6	Timer and counter support .....	89
D.4	Capabilities of FP under test .....	90
D.4.1	Services .....	90
D.4.2	Messages.....	90
D.4.3	Message parameters .....	93
D.4.4	Procedure support.....	96
D.4.5	CSF multiplexing functions.....	97
D.4.6	Timer and counter support .....	98
Annex E (normative):	Measurement of BER .....	99
Annex F (informative):	Procedures for the measurement of synchronisation loss at the EUT by the LT.....	100
F.1	Description.....	100
F.2	Method.....	100
History	.....	101



## Foreword

This draft 2nd edition Technical Basis for Regulation (TBR) has been produced by the Radio Equipment and Systems (RES) Technical Committee of the European Telecommunications Standards Institute (ETSI) and is now submitted for the Public Enquiry phase of the ETSI standards approval procedure.

<b>Proposed transposition dates</b>	
Date of latest announcement of this ETS (doa):	3 months after ETSI publication
Date of latest publication of new National Standard or endorsement of this ETS (dop/e):	6 months after doa
Date of withdrawal of any conflicting National Standard (dow):	6 months after doa

Blank page

## 1 Scope

This TBR covers the general attachment requirements for terminal equipment for the Digital European Cordless Telecommunications (DECT) common interface.

This TBR contains the procedures and requirements for the type examination of DECT equipment.

DECT equipment capable of being physically attached to the public network also needs to meet the appropriate attachment requirements. Speech attachment requirements are covered in TBR 10.

This TBR is based on the DECT Common Interface (CI) given in ETS 300 175 [1] to [7] and I-ETS 300 176 [13].

Clause 18 of this TBR contains changes to text in ETS 300 175-3 [3] and should therefore be read in conjunction with this TBR. ETS 300 175-3 [3] will be amended in due course to reflect these changes, following the normal ETSI amendment procedure.

This TBR specifies the technical characteristics to be provided by terminal equipment which is capable of connection to a public telecommunications network and which uses DECT cordless communications for network access. The cordless transmissions for such terminal equipment operate within the frequency band 1 880 - 1 900 MHz.

The objective of this TBR is to ensure that no disturbance occurs to the public network, and to ensure interworking between network and terminal so that calls can be routed successfully through the network, but without any guarantee of terminal to terminal operation.

The requirements in this TBR applies together with the attachment requirements for the appropriate public network (see note) and the requirements of any other relevant TBR. It does not add to or reduce the attachment requirements unless there is a particular effect on the network which is unique to DECT.

NOTE: TBR for basic ISDN, TBR for primary rate ISDN, or national regulations (implementing ETS 300 001) for PSTN. Interconnection of a DECT terminal to a GSM network is still under study; in due course, the scope statement may need amending to reflect this point.

A DECT terminal equipment comprises two elements, referred to as a Fixed Part (FP) and a Portable Part (PP). This TBR is structured to allow type approval of the FP and PP as separate items.

Because of the need for effective use of the radio frequency spectrum, the air interface characteristics between FP and PP are tested.

For each requirement, a test is given, including measurement methods. Requirements apply at the public network interface of the terminal equipment, which may be stimulated to perform the tests by additional equipment if necessary.

Terminal equipment may be subject to additional or alternative requirements in other CTRs depending on its functionality, in particular if it supports a service which is considered a justified case for regulation of terminal equipment interworking via the public telecommunications network.

## 2 Normative references

This Technical Basis for Regulation (TBR) incorporates, by dated or undated reference, provisions from other publications. These normative references are cited at the appropriate places in the text and the publications are listed hereafter. For dated references, subsequent amendments to, or revisions of any of these publications apply to this TBR only when incorporated in it by amendment or revision. For undated references the latest edition of the publication referred to applies.

- [1] ETS 300 175-1 (1992): "Radio Equipment and Systems (RES); Digital European Cordless Telecommunications (DECT); Common Interface (CI); Part 1: Overview".
- [2] ETS 300 175-2 (1992): "Radio Equipment and Systems (RES); Digital European Cordless Telecommunications (DECT); Common Interface (CI); Part 2: Physical Layer (PHL)".
- [3] ETS 300 175-3 (1992): "Radio Equipment and Systems (RES); Digital European Cordless Telecommunications (DECT); Common Interface (CI); Part 3: Medium Access Control (MAC) layer".
- [4] ETS 300 175-4 (1992): "Radio Equipment and Systems (RES); Digital European Cordless Telecommunications (DECT); Common Interface (CI); Part 4: Data Link Control (DLC) layer".
- [5] ETS 300 175-5 (1992): "Digital European Cordless Telecommunications Common Interface (CI); Part 5: Network (NWK) layer".
- [6] ETS 300 175-6 (1992): "Digital European Cordless Telecommunications Common Interface (CI); Part 6: Identities and addressing".
- [7] ETS 300 175-7 (1992): "Digital European Cordless Telecommunications Common Interface (CI); Part 7: Security features".
- [8] ISO Publication ISO/IEC 9646-1 (1991): "Conformance testing methodology and framework, Part 1: General concepts".
- [9] CCITT Recommendation V.11 (1988): "Electrical characteristics for balanced double-current interchange circuits for general use with integrated circuit equipment in the field of data communications".
- [10] CCITT Recommendation O.153 (1988): "Characteristics of distortion and error-rate measuring apparatus for data transmission".
- [11] 91/263/EEC: "Council Directive of 29 April 1991 on the approximation of the laws of the Member States concerning telecommunications terminal equipment, including the mutual recognition of their conformity". (Terminal Directive).
- [12] EN 55022: "Limits and methods of measurements of radio interferers characteristics of information technology equipment".
- [13] I-ETS 300 176 (1992): "Radio Equipment and Systems (RES); Digital European Cordless Telecommunications (DECT) Approval test specification".

### 3 Definitions and abbreviations

#### 3.1 Definitions

For the purposes of this TBR, the following definitions apply:

**antenna diversity:** Antenna diversity implies that the RFP for each bearer independently can select different antenna properties such as gain, polarisation, coverage patterns, and other features that may effect the practical coverage. A typical example is space diversity, provided by two vertically polarized antennas separated by 10 - 20 cm.

**bearer handover:** The internal handover process provided by the MAC layer, whereby one MAC connection can modify its underlying bearers while maintaining the service provided to the DLC layer.

NOTE 1: Bearer handover is slot based.

**cell:** The domain served by a single antenna system (including a leaky feeder) of one fixed part.

NOTE 2: A cell may include more than one source of radiated RF energy (i.e. more than one radio end point).

**Central Control Fixed Part (CCFP):** A physical grouping that contains the central elements of a fixed part. A fixed part shall contain a maximum of one CCFP.

NOTE 3: A CCFP controls one or more RFPs.

**conducted measurements:** Measurements which are made using a direct connection to the equipment under test.

**DECT-like carrier:** A modulated RF DECT carrier used for interference testing which conforms to the requirements in ETS 300 175-2 [2] in terms of frequency and timing and uses a pseudo-random sequence for modulation.

**double slot (slot):** One 12th of a TDMA frame which is used to support one high capacity physical channel.

**duplex bearer:** The use of two simplex bearers operating in opposite directions on two physical channels. These pairs of channels always use the same RF carrier and always use evenly spaced slots (i.e. separated by 0,5 TDMA frame).

**Equipment Under Test (EUT):** The equipment submitted to a test laboratory for type examination.

**Fixed Part (DECT fixed part) (FP):** A physical grouping that contains all of the elements in the DECT network between the local network and the DECT air interface.

NOTE 4: A DECT FP contains the logical elements of at least one Fixed radio Termination (FT), plus additional implementation specific elements.

**Fixed radio Termination (FT):** A logical group of functions that contains all of the DECT processes and procedures on the fixed side of the DECT air interface.

NOTE 5: A FT only includes elements that are defined in the DECT CI standard. This includes radio transmission elements (layer 1) together with a selection of layer 2 and layer 3 elements.

**full slot (slot):** One 24th of a TDMA frame which is used to support one physical channel.

**half slot:** One 48th of a TDMA frame which is used to support one physical channel.

**handover:** The process of switching a call in progress from one physical channel to another physical channel. These processes can be internal (see internal handover) or external (see external handover).

NOTE 6: There are two physical forms of handover: intra-cell handover and inter-cell handover. Intra-cell handover is always internal. Inter-cell handover can be internal or external.

**host equipment:** Is any equipment which has a complete user functionality when not connected to the DECT radio equipment, and to which the DECT radio equipment provides additional functionality, and to which connection is necessary for the DECT radio equipment to offer functionality.

**inter-cell handover:** The switching of a call in progress from one cell to another cell.

NOTE 7: This only defines the form of handover, it does not define a specific process.

**intra-cell handover:** The switching of a call in progress from one physical channel of one cell to another physical channel of the same cell.

NOTE 8: This only defines the form of handover, it does not define a specific process.

**Lower Tester (LT):** A logical grouping that contains the test equipment, a functionally equivalent DECT PT, a functionally equivalent DECT FT and a test controller.

**multiframe:** A repeating sequence of 16 successive TDMA frames, that allows low rate or sporadic information to be multiplexed (e.g. basic system information or paging).

**physical channel (channel):** The simplex channel that is created by transmitting in one particular slot on one particular RF channel in successive TDMA frames. See also simplex bearer.

NOTE 9: One physical channel provides a simplex service. Two physical channels are required to provide a duplex service.

**Portable HandSet (PHS):** A single physical grouping that contains all of the portable elements that are needed to provide a teleservice to the user.

NOTE 10: Portable handset is a subset of all possible PPs. This subset includes all physical groupings that combine one PT plus at least one portable application in a single physical box.

**Portable Part (PP):** A physical grouping that contains all elements between the user and the DECT air interface. PP is a generic term that may describe one or several physical pieces.

NOTE 11: A PP is logically divided into one portable termination plus one or more portable applications.

**Portable radio Termination (PT):** A logical group of functions that contains all of the DECT processes and procedures on the portable side of the DECT air interface.

NOTE 12: A PT only includes elements that are defined in the DECT CI standard. This includes radio transmission elements together with a selection of layer 2 and layer 3 elements.

**radiated measurements:** Measurements which involve the absolute measurement of a radiated field.

**Radio EndPoint (REP):** A physical grouping that contains one radio transmitter/receiver, fixed or portable.

NOTE 13: A REP may operate only as a receiver or only as a transmitter.

**Radio Fixed Part (RFP):** One physical sub-group of a FP that contains all the REPs (one or more) that are connected to a single system of antennas.

**simplex bearer:** The MAC layer service that is created using one physical channel.

**TDMA frame:** A time-division multiplex of 10 ms duration, containing 24 successive full slots. A TDMA frame starts with the first bit period of full slot 0 and ends with the last bit period of full slot 23.

**test laboratory:** A body which performs testing in accordance with the terminal directive. This laboratory is accredited to perform 3rd party testing.

**test load:** The test load is a substantially non-reactive, non-radiating power attenuator which is capable of safely dissipating the power from the transmitter(s).

**Upper Tester (UT):** A logical grouping that controls the EUT when under test.

NOTE 14: Commands are sent from the LT to the UT to place the EUT in the appropriate test mode.

### 3.2 Abbreviations

For the purposes of this TBR, the following abbreviations apply:

BER	Bit Error Ratio
CI	Common Interface
dBm	dB relative to 1 milliwatt
EIRP	Equivalent Isotropically Radiated Power
EMC	Electromagnetic Compatibility
EUT	Equipment Under Test
FP	Fixed Part
FT	Fixed radio Termination
IPEI	International Portable part Equipment Identity
LT	Lower Tester
NTP	Normal Transmitted Power
PP	Portable Part
PSN	Portable equipment Serial Number
PT	Portable radio Termination
RFP	Radio Fixed Part
TBC	Traffic Bearer Controller
TDMA	Time Division Multiple Access
UT	Upper Tester

## 4 General

### 4.1 Document layout

The test cases described in these clauses are intended to follow the ISO Publication 9646-1 [8] recommendations as closely as possible. However, for practical reasons it is not always possible to follow the guide-lines exactly and the following paragraphs describe the relationship of this TBR to ISO Publication 9646-1 [8].

#### 4.1.1 Test suites

The term "test suite" is defined in ISO Publication 9646-1 [8].

Table 1 lists the test suite that is described in this TBR and the test groups that are associated with it.

**Table 1**

Test suite	Test groups
DECT physical layer	Physical layer services Transmission of physical packets Reception of physical packets Synchronisation Equipment identities Efficient use of radio spectrum

#### 4.1.2 Test groups

The term "test group" is defined in ISO Publication 9646-1 [8].

Table 2 lists the test groups that are described in this TBR and the test cases that are associated with them.

**Table 2**

Test group	Test cases
Physical layer services	1 2 4
Transmission of physical packets	5 6 7 8 9 10 11 12
Reception of physical packets	14 15 16 17 18 19 20
Synchronisation	21
Equipment identities	23
Efficient use of radio spectrum	24

#### 4.1.3 Test cases

The term "test case" is defined in ISO Publication 9646-1 [8].

Table 3 lists the test cases that are described in this TBR.

**Table 3**

Test Case	Test case	clause \ subclause Number
1	Accuracy and stability of RF carriers	7
2	Timing jitter: slot-slot on the same channel	8.3
3	no longer required	
4	Reference timing accuracy of a RFP	8.4
4b	Measurement of packet transmission accuracy	8.5
5	Transmission Burst	9
6	Transmitted power: PP and RFP with an integral antenna	10.2
7	Transmitted power: PP and RFP with an external antenna connector	10.3
8	RF carrier modulation	11
9	Emissions due to modulation	12.2
10	Emissions due to transmitter transients	12.3
11	Emissions due to intermodulation	12.4
12	Spurious emissions when allocated a transmit channel	12.5
13	no longer required	
14	Radio receiver sensitivity	13.1
15	Radio receiver reference bit error ratio	13.2
16	Radio receiver interference performance	13.3
17	Radio receiver blocking case 1	13.4
18	Radio receiver blocking case 2	13.5
19	Receiver intermodulation performance	13.6
20	Spurious emissions when the radio endpoint has no allocated transmit channel	13.7
21	Synchronisation port	14
22	EMC	15
23	Equipment identity verification/safeguards	16
24	Efficient use of radio spectrum	17

Annex C provides a summary of the essential requirement articles of the Terminal Directive [11] justifying the tests in this TBR.



## **4.2 Presentation of equipment for testing purposes**

Each equipment submitted for type examination shall fulfil the requirements of this TBR on all DECT RF channels.

### **4.2.1 Choice of model for type examination**

The applicant shall provide one or more preliminary or production model(s) of the equipment, as appropriate, for type examination.

If approval is given on the basis of tests on a preliminary model, then the corresponding production models shall be identical in all respects with the preliminary model tested.

### **4.2.2 Description of equipment**

The applicant shall provide the following information to the test laboratory.

#### **4.2.2.1 Protocol Implementation Conformance Statement (PICS)**

A PICS is a statement made by the applicant stating which capabilities and options have been implemented.

#### **4.2.2.2 Protocol Implementation eXtra Information for Testing (PIXIT)**

A PIXIT is a statement made by the applicant which contains or references all of the information (in addition to that given in the PICS) related to the EUT and its testing environment, which will enable the test laboratory to run an appropriate test suite against the EUT.

This shall include:

- the method by which the equipment can be switched into the test standby mode. This mode is described in subclause 5.9.2;
- whether the equipment has one or more internal or external antennas;
- whether the equipment has antenna diversity.

#### **4.2.2.3 Environmental test conditions**

The applicant shall supply for FPs, RFPs, and CCFPs, a statement indicating the class of use for the EUT, i.e. "Class E1 Use" or "Class E2 Use".

### **4.2.3 Host connected equipment**

The applicant shall supply a statement indicating which of the test configurations detailed in subclause 6.7 shall be used for approval of DECT equipment for which connection to, or integration with, host equipment is required to offer functionality.

### **4.2.4 Applicant's declaration**

Where parameters, capabilities, etc., are subject to the applicant's declaration and not a specific test, it shall be the applicant's responsibility to:

- a) supply a declaration of implementation, in which the applicant explicitly affirms the implementation in the equipment of certain parameters and capabilities;
- b) be prepared to submit upon request supporting design information, including circuit designs and software source code, demonstrating the implementation of said capabilities;

- c) be prepared to supply upon request such test results as are practicable, including the test methods, which support the declaration.

### **4.3 Applicability of type tests**

The applicability of the individual type tests in this TBR are dependent on the type of equipment submitted for approval. The following subclauses list the applicable type tests. Equipment may contain one or more of the features listed in the following subclauses. It is assumed that all equipment contains a radio receiver. The type tests described in this TBR shall only be applied to the equipment physically containing a DECT RF receiver and/or transceiver.

#### **4.3.1 All equipment**

The type test specified in subclause 13.7 of this TBR shall be applied. Control lines to the EUT necessary for its operation shall be permitted.

#### **4.3.2 Equipment that includes a radio transmitter**

The type tests contained in clauses 7, 8, 9, 10, 11, 12, 13 and 17 of this TBR shall be applied.

#### **4.3.3 Equipment that is equipped with an analogue port**

Additional national type tests may be applied to equipment that are equipped with an analogue port.

#### **4.3.4 Equipment with a synchronisation port**

The type tests contained in clause 14 of this TBR shall be applied.

#### **4.3.5 Equipment incorporating the IPEI (PPs only)**

The type test contained in subclause 16.1 of this TBR shall be applied.

#### **4.3.6 All FP equipment**

The type test contained in subclause 16.2 of this TBR shall be applied.

### **4.4 Interpretation of the measurement results**

The interpretation of the results recorded in a test report for the measurements described in this TBR shall be as follows:

- a) the measured value related to the corresponding limit shall be used to decide whether an equipment meets the minimum requirements of the standard;
- b) the actual measurement uncertainty of the test laboratory carrying out the measurement, for each particular measurement, shall be included in the test report;
- c) the values of the actual measurement uncertainty shall be, for each measurement, equal to or lower than the figures in subclause 5.8.5 (table of measurement uncertainty).

## 5 General test requirements

### 5.1 Test philosophy

All the tests in this TBR are based upon a common philosophy. This philosophy assumes that test equipment is capable of emulating a PT or FT that conforms to the DECT CI specification. Consequently, each test set-up consists of the test equipment being connected to the EUT, either by a radio link or via an antenna connector. The following figures show the possible test configurations.

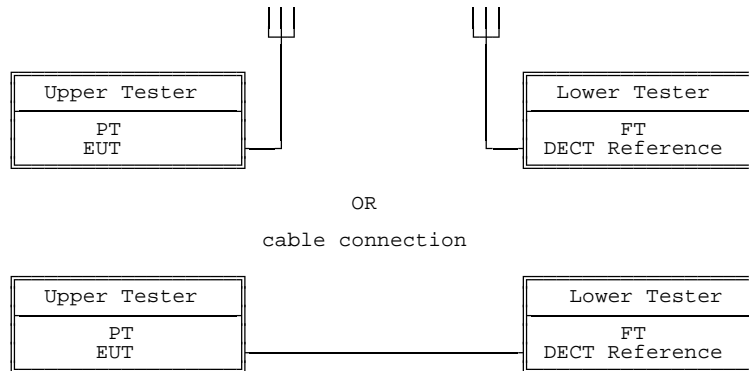

**Figure 1: The EUT as a PT**

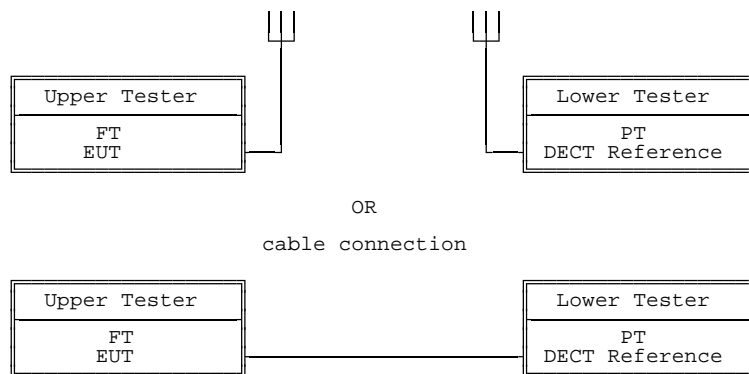

**Figure 2: The EUT as an FT**

Figures 1 and 2 also show that, if available, the EUT can sometimes be connected to the LT by an antenna connector. This is normally preferred in order to minimise the measurement uncertainties. However, in some test cases this is not permitted and is stated as such in each test case.

The LT shall consist of the general test equipment with the functionality as described in subclause 5.8. Also it shall include an RF interface which can emulate a DECT PT, or FT. The emulated DECT PT and FT (see subclause 5.10) is an implementation of the DECT CI specification including all the mandatory services and facilities and some provision optional, process mandatory elements as well.

The UT is contained within the EUT and operates in response to test commands which are sent by the LT over the air interface. This enables the LT to place the EUT in a variety of test modes. These are described in subclause 5.9.

## 5.2 Test site

### 5.2.1 Open air test site

#### 5.2.1.1 Description

The term "open air" shall be understood from an electromagnetic point of view. Such a test site may be really in open air or, alternatively, with walls and ceiling transparent to the radio waves at the frequencies considered.

An open air test site may be used to perform the measurements using the radiated measurement methods described in annex B of this TBR in the frequency range over which the site may be calibrated. Absolute or relative measurements may be performed on transmitters or receivers; absolute measurements require a calibration of the test site.

The distance between the equipment under test or substitution antenna and the test antenna shall be in accordance with current testing practice. Measuring distances of 3, 5, 10, and 30 m are in common use in European test laboratories. A measurement distance of 1 metre may be used for frequencies above 1 GHz if the dimensions of the test antenna is less than  $[1 \text{ metre} \times \lambda/2]^{1/2}$ .

The test site shall be large enough to allow the erection of a measuring or transmitting antenna at a distance of  $\lambda/2$  at the frequency of measurement or 3 meters (1 metre above 1 GHz), whichever is the greater. The height of the equipment or of the substitution antenna shall be 1,5 m; the height of the test antenna (transmit or receive) shall be variable between 1 and 4 m. The support for the equipment or substitution antenna shall be capable of 360° rotation and be made of a non-conductive material. The overall size of the open air test site shall be approximately 2 x D m by 3 x D m, where D is the measuring distance.

To eliminate errors caused by reflection coefficient variation from one measurement geometry to another, the standard ground plane should be substantially flat and horizontal; it should be made from a highly conductive metal. It must be large enough (at least 5 meters in diameter) to provide consistent ground reflections. The support for the equipment or substitution antenna shall be positioned in the middle of the ground plane. Sufficient precautions shall be taken to ensure that reflections from extraneous objects adjacent to the site do not degrade the measurement results, in particular:

- no extraneous conducting objects having any dimension in excess of a quarter wavelength of the highest frequency tested shall be in the immediate vicinity of the site;
- all cables shall be as short as possible; as much of the cables as possible shall be on the ground plane or preferably below and the low impedance cables shall be screened.

### 5.2.1.2 Calibration

The calibration allows the creation, in a given place, of a known field strength by the means of a signal generator connected to a substitution antenna. The calibration is valid only at a given frequency for a given polarisation and for the exact position of the test antenna.

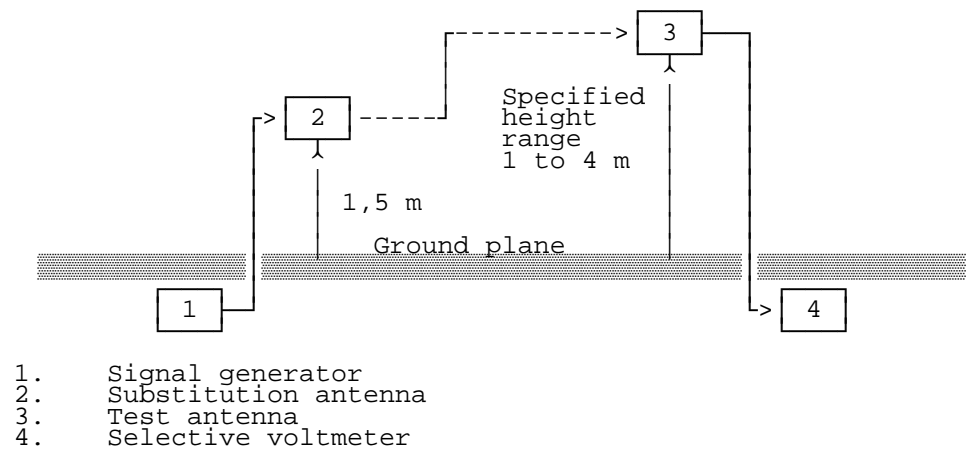

**Figure 3: Measuring arrangement for calibration**

All the equipment shall be adjusted to the frequency at which the calibration is to be performed.

The test antenna and the substitution antenna shall have the same polarisation.

The test antenna connected to the selective voltmeter constitutes a calibrated field strength meter:

- the signal generator level shall be adjusted to produce the required field strength as measured on the selective voltmeter;
- the test antenna shall be raised or lowered through the specified range until the maximum signal level is detected on the selective voltmeter;
- the signal generator level shall be readjusted to produce the required field strength as measured on the selective voltmeter. Thus a relationship has been established between the signal generator level and the field strength.

### 5.2.2 Anechoic chamber

#### 5.2.2.1 General

An anechoic chamber is a well shielded chamber covered inside with radio frequency absorbing material and simulating a free space environment. It is an alternative site on which to perform the measurements using the radiated measurement methods described in annex B of this TBR in the frequency range over which it may be calibrated. Absolute or relative measurements may be performed on transmitters or on receivers. Absolute measurements require a calibration of the anechoic chamber. The test antenna, equipment under test and substitution antenna are used in a way similar to that at the open air test site, but are all located at the same fixed height above the floor.

#### 5.2.2.2 Description

An anechoic chamber should meet the requirements for shielding loss and wall return loss as shown in figure 4 Figure 5 shows an example of the construction of an anechoic chamber having a base area of 5 m by 10 m and a height of 5 m.

The ceiling and walls are coated with pyramidally formed absorbers approximately 1 m high. The base is covered with special absorbers which form the floor. The available internal dimensions of the chamber are 3 m x 8 m x 3 m, so that a maximum measuring distance of 5 m in the middle axis of this chamber is available (for more information, refer to ZVEI AK-R 90/20, (see annex A)). The floor absorbers reject floor reflections so that the antenna height need not be changed. Anechoic chambers of other dimensions may be used.

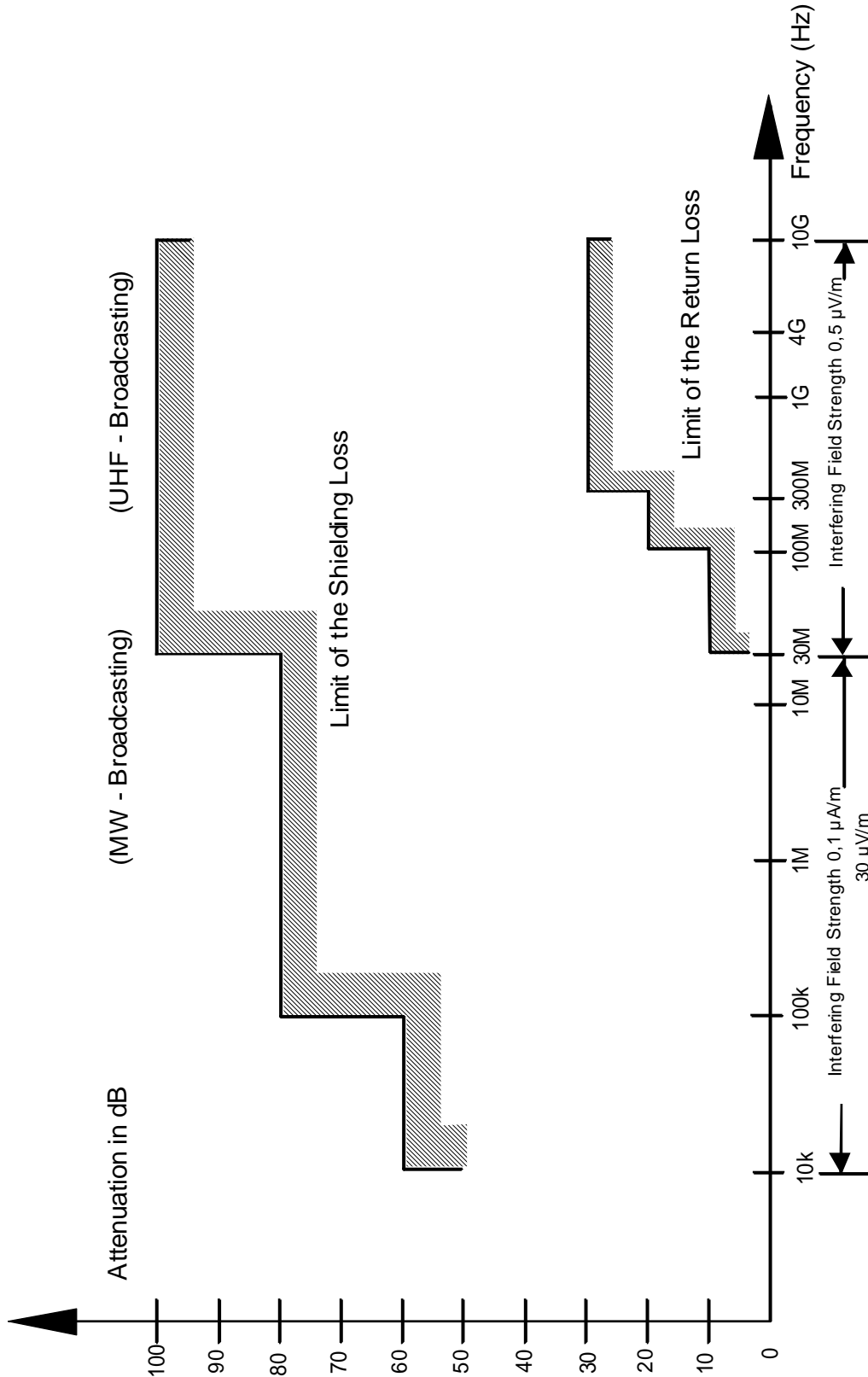
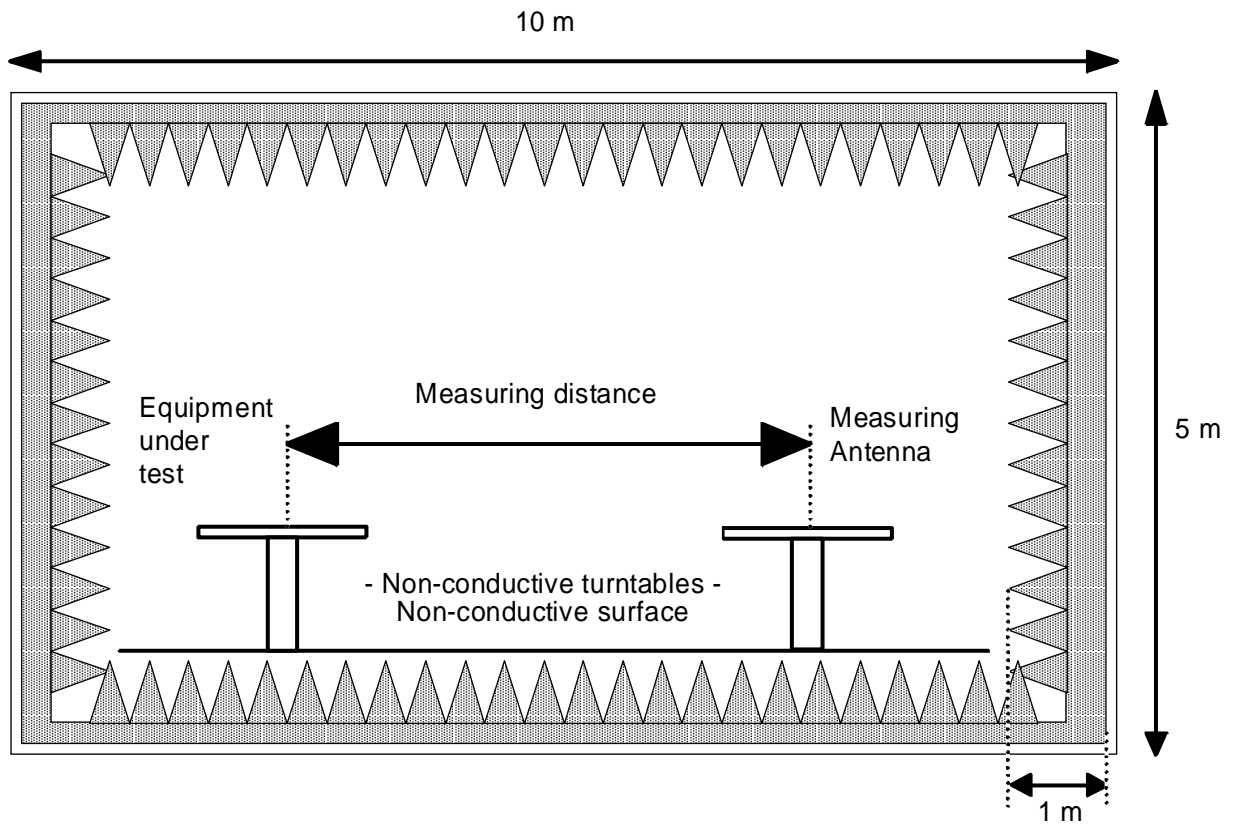

Figure 4



Ground Plan

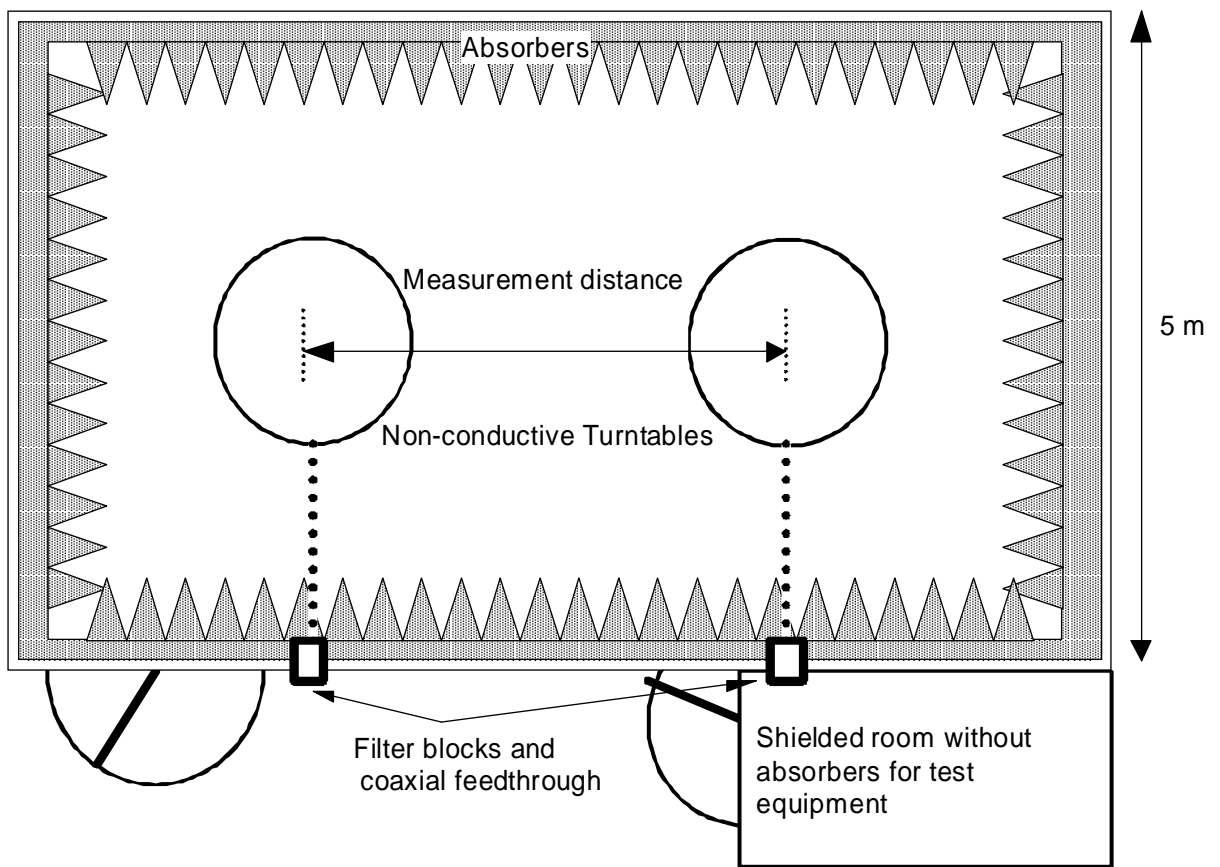

Figure 5

### 5.2.2.3 Influence of parasitic reflections

For free-space propagation in the far field the relationship of the field strength  $X$  and the distance  $R$  is given by  $X = X_0 \times (R_0/R)$ , where  $X_0$  is the reference field strength and  $R_0$  is the reference distance. This relationship allows relative measurements to be made as all constants are eliminated within the ratio and neither cable attenuation nor antenna mismatch or antenna dimensions are of importance.

If the logarithm of the above equation is used, the deviation from the ideal curve can be easily seen because the ideal correlation of field strength and distance appears as a straight line. The deviations occurring in practice are then clearly visible. This indirect method shows quickly and easily any disturbances due to reflections and is far less difficult than the direct measurement of reflection attenuation.

With an anechoic chamber of the dimensions given above at low frequencies below 100 MHz there are no far field conditions, but the wall reflections are stronger, so that careful calibration is necessary. In the medium frequency range from 100 MHz to 1 GHz the dependence of the field strength to the distance meets the expectations very well. Above 1 GHz, because more reflections will occur, the dependence of the field strength to the distance will not correlate so closely.

### 5.2.2.4 Calibration and mode of use

The calibration and mode of use is the same as for an open air test site, the only difference being that the test antenna does not need to be raised and lowered whilst searching for a maximum, which simplifies the method of measurement.

## 5.2.3 Stripline coupler

The stripline arrangement is a RF coupling device for coupling the integral antenna of an equipment to a 50  $\Omega$  radio frequency terminal. This allows the radiated measurements described in clause 5 to be performed without an open air test site but in a restricted frequency range. Absolute or relative measurements may be performed; absolute measurements require a calibration of the stripline arrangement.

### 5.2.3.1 Description

The stripline is made of three highly conductive sheets forming part of a transmission line which allows the equipment under test to be placed within a known electric field. They shall be sufficiently rigid to support the equipment under test.

An example of stripline characteristics is given below:

Useful frequency range	MHz	0,1 to 4 000
Equipment size limits	length	1 200 mm
(antenna included):	width	1 200 mm
	height	400 mm

Refer to report FTZ N<sup>o</sup> 512 TB 9 (see annex A) for more information.

### 5.2.3.2 Calibration

The aim of calibration is to establish at any frequency a relationship between the voltage applied by the signal generator and the field strength at the designated test area inside the stripline.

### 5.2.3.3 Mode of use

The stripline arrangement may be used for all radiated measurements within its calibrated frequency range.

The method of measurement shall be the same as the method using an open air test site except that the stripline arrangement input socket shall be used instead of the test antenna.



### 5.3 Standard position

The standard position in all test sites, except the stripline arrangement, for equipment which is not intended to be worn on a person, including hand-held equipment, shall be on a non-conducting support, height 1,5 m, capable of rotating about a vertical axis through the equipment. The standard position of the equipment shall be the following:

- a) for equipment with an integral antenna, it shall stand so that the axis of the equipment which in its normal use is closest to the vertical shall be vertical;
- b) for equipment with a rigid external antenna, the antenna shall be vertical;
- c) for equipment with a non-rigid external antenna, the antenna shall be extended vertically upwards by a non-conducting support.

In the stripline arrangement the EUT, or the substitution antenna, is placed in the designated test area in the normal operational position, relative to the applied field, on a pedestal made of a low dielectric material (dielectric constant less than 2).

### 5.4 Test antenna of the LT

When the test site is used for radiation measurements the test antenna shall be used for reception of the field from both the test sample and the substitution antenna. When the test site is used for the measurement of receiver characteristics the antenna shall be used as a transmitting antenna. This antenna shall be mounted on a support capable of allowing the antenna to be used in either a horizontal or vertical polarization and for the height of its centre above the ground to be varied over the specified range. Preferably test antennas with pronounced directivity should be used. The size of the test antenna along the measurement axis shall not exceed 20 % of the measuring distance.

### 5.5 Substitution antenna

A substitution antenna shall be used to replace the equipment under test. For measurements below 1 GHz the substitution antenna shall be a half wavelength dipole resonant at the frequency under consideration, or a shortened dipole, calibrated to the half wavelength dipole. For measurements between 1 and 4 GHz either a half wavelength dipole or a horn radiator may be used.

For measurements above 4 GHz a horn radiator shall be used. The centre of this antenna shall coincide with the reference point of the test sample it has replaced. This reference point shall be the volume centre of the sample when its antenna is mounted inside the cabinet, or the point where an outside antenna is connected to the cabinet.

The distance between the lower extremity of the dipole and the ground shall be at least 30 cm.

NOTE: The gain of a horn antenna is generally expressed relative to an isotropic radiator.

### 5.6 Test fixture

#### 5.6.1 Description

The test fixture is a radio frequency coupling device associated with an integral antenna equipment for coupling the integral antenna to a 50 ohm radio frequency terminal at the working frequencies of the equipment under test. This allows certain measurements to be performed using the conducted measurement methods. Measurements may only be performed at or near frequencies for which the test fixture has been calibrated.

In addition, the test fixture shall provide:

- a connection to an external power supply; and
- interfaces to other relevant inputs and outputs.

The test fixture shall normally be provided by the applicant.

The performance characteristics of the test fixture shall be approved by the test laboratory and shall conform to the following basic parameters:

- the coupling loss shall not be greater than 20 dB;
- a coupling loss variation over the frequency range used in the measurement which does not exceed 2 dB;
- circuitry associated with the RF coupling shall contain no active or non linear devices;
- the VSWR at the 50 ohm socket shall not be greater than 1,5 over the frequency range of the measurements;
- the coupling loss shall be independent of the position of the test fixture and be unaffected by the proximity of surrounding objects or people. The coupling loss shall be reproducible when the equipment under test is removed and replaced;
- the coupling loss shall remain substantially constant when the environmental conditions are varied.

The characteristics and calibration shall be included in the test report.

#### 5.6.1.1 Calibration of the test fixture for the measurement of transmitter characteristics

The calibration of the test fixture establishes a relationship between the output of the test fixture and the output of the equipment inside the test fixture.

The calibration is valid only at a given frequency or range of frequencies and for a given polarisation of the reference field.

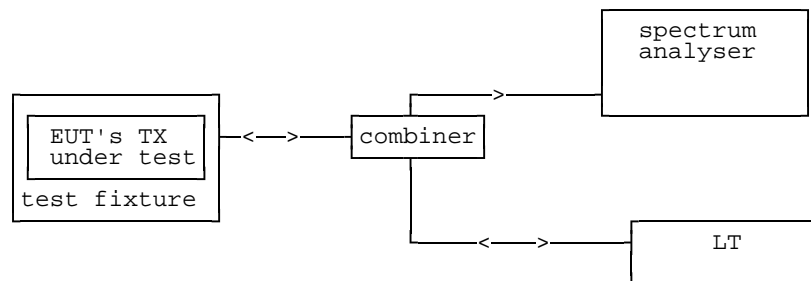

Figure 6: Measuring arrangement for calibration

- a) Using the appropriate method described in subclauses 10.2 and 10.3 (transmitted power) measure the NTP and note the value of this power and the polarisation used.
- b) The transmitter shall be placed in the test fixture which is connected to the spectrum analyser. The measured level in dBm shall be noted.
- c) The calibration for the test fixture is the linear relationship between the measured power in dBm according to clause 10 (transmitted power) and the measured power in dBm in this calibration set-up.

#### 5.6.1.2 Calibration of the test fixture for the measurement of receiver characteristics

The calibration of the test fixture establishes a relationship between the level of the signal connected to the test fixture and the field strength applied to the equipment inside the test fixture.

The calibration is valid only at a given frequency and for a given polarisation of the reference field.

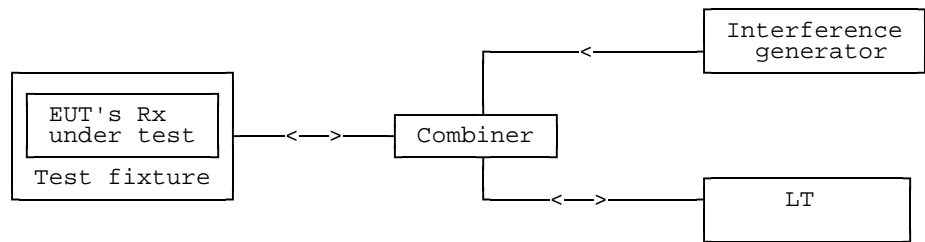

**Figure 7: Measuring arrangement for calibration**

- a) Using the method described in annex B of this TBR, measure the sensitivity expressed as field strength for a bit error ratio of 0,001 or less and note the value of this field strength in dB $\mu$ V/m and the polarisation used.
- b) The receiver shall be placed in the test fixture which is connected to the LT (with bit-error measuring test facilities). The level of the signal connected to the test fixture producing the same bit error ratio measured according to the method used in step a) shall be noted.
- c) The calibration of the test fixture is thus the linear relationship between field strength in dB $\mu$ V/m and the signal generator level in dB $\mu$ V e.m.f.

### 5.6.1.3 Mode of use

A test fixture may be used for tests under extreme temperatures and for transmitter and receiver measurements that can be carried out with an uncalibrated test fixture.

If the calibrated test fixture is used as an alternative for the test site then its use, the characteristics and the calibration shall be recorded in the test report.

### 5.6.2 Equipment with a temporary or internal permanent antenna connector

The means to access and/or implement the internal permanent or temporary antenna connector shall be stated by the applicant with the aid of a diagram.

The fact that use has been made of the internal antenna connection to facilitate measurements shall be recorded in the test report.

All references in this TBR to antenna connector, external antenna connector and temporary connectors shall be understood to be identical and to mean an external antenna connector and/or temporary and/or internal permanent connector.

#### 5.6.2.1 Equipment with a temporary antenna connector

The applicant, or an authorised representative, may submit one set of equipment with the normal antenna connected, to enable the radiated measurements to be made.

The applicant, or an authorised representative, shall attend the test laboratory at the conclusion of the radiated measurements, to disconnect the antenna and fit the temporary connector.

The test laboratory staff shall not connect or disconnect any temporary antenna connector.

Alternatively the applicant, or an authorised representative, may submit two sets of equipment to the test laboratory, one fitted with a temporary antenna connector with the antenna disconnected and the other with the antenna connected.

Each equipment shall be used for the appropriate tests.

### 5.7 Indoor test site

An indoor test site may be used instead of an open air test site or an anechoic room. However, the open air test site or the anechoic room are preferred. Each test case lists the allowed test sites.

#### 5.7.1 Description

An indoor test site is a partially screened site, where the wall located behind the test sample is covered with a radio frequency absorbing material and a corner reflector is used with the test antenna. It may be used when the frequency of the signals being measured is greater than 80 MHz.

The measurement site may be a laboratory room with a minimum area of 6 m by 7 m and at least 2,7 m in height.

Apart from the measuring apparatus and the operator, the room shall be as free as possible from reflecting objects other than the walls, floor and ceiling.

The site arrangement is shown in figure 8 for horizontal polarisation.

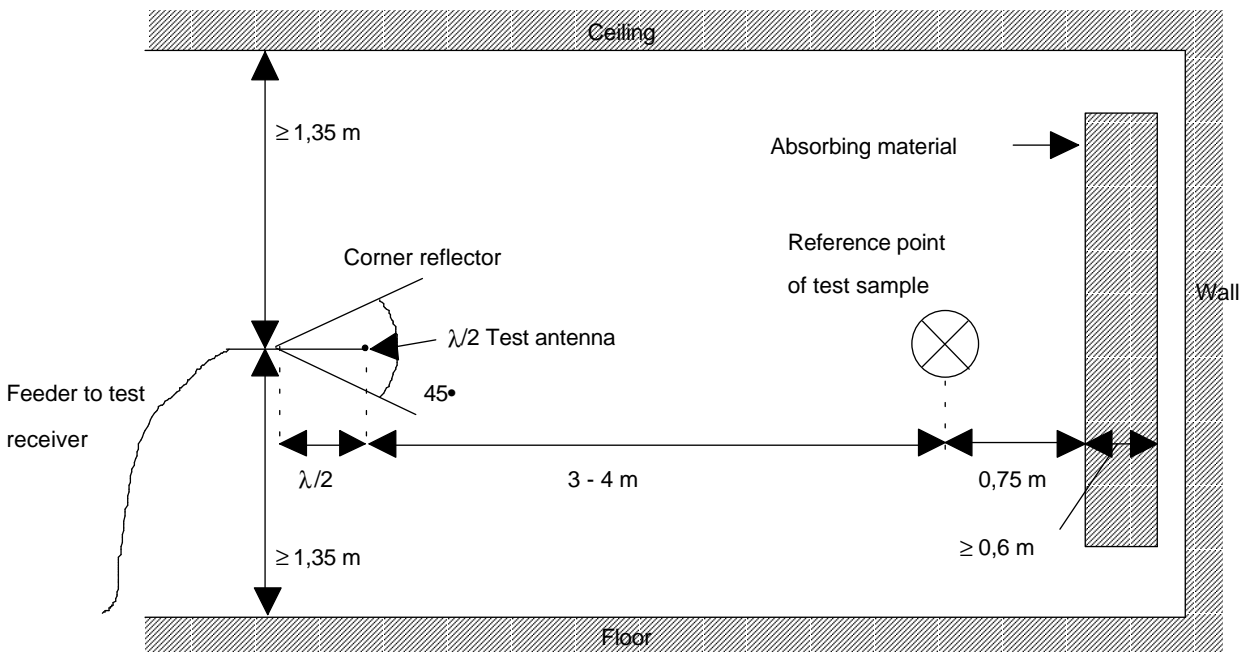

Figure 8: Indoor test site arrangement (shown for horizontal position)

The potential reflections from the wall behind the equipment under test shall be reduced by placing a barrier of absorbent material in front of the wall. The corner reflector around the test antenna shall be used to reduce the effect of reflections from the opposite wall and from the floor and ceiling in the case of horizontally polarised measurements. Similarly, the corner reflector reduces the effects of reflections from the side walls for vertically polarised measurements. For the lower part of the frequency range (below approximately 175 MHz) no corner reflector or absorbent barrier is needed. For practical reasons, the half wavelength antenna in figure 4 may be replaced by an antenna of constant length, provided that this length is between a quarter wavelength and one wavelength at the frequency of measurement and the sensitivity of the measuring system is sufficient. In the same way the distance of half wavelength to the apex may be varied.

#### 5.7.2 Test for parasitic reflections

To ensure that errors are not caused by the propagation path approaching the point at which phase cancellation between direct and the remaining reflected signals occurs, the substitution antenna shall be moved through a distance of ± 10 cm in the direction of the test antenna as well as in the two directions perpendicular to this first direction.

If these changes of distance cause a signal change of greater than 2 dB, the test sample should be repositioned until a change of less than 2 dB is obtained.

### 5.7.3 Calibration and mode of use

The calibration and mode of use is the same as for an open air test site, the only difference being that the test antenna does not need to be raised and lowered whilst searching for a maximum, which simplifies the method of measurement.

## 5.8 Lower Tester (LT)

### 5.8.1 Description

The lower tester is a logical grouping that contains a DECT PT, DECT FT, the measurement equipment and the controller of the DECT testing system. The LT has the job of sending testing commands, performing calculations (e.g. signal processing) and interacting with the EUT for the various tests. The LT may implement the Test Support Profile (TSP) described in annex D in order to support the test messages and procedures in a fully standardised manner. This unit is also involved with DECT RF carrier generation, reception, and demodulation. In addition, the LT has wideband RF requirements for emissions and interference testing.

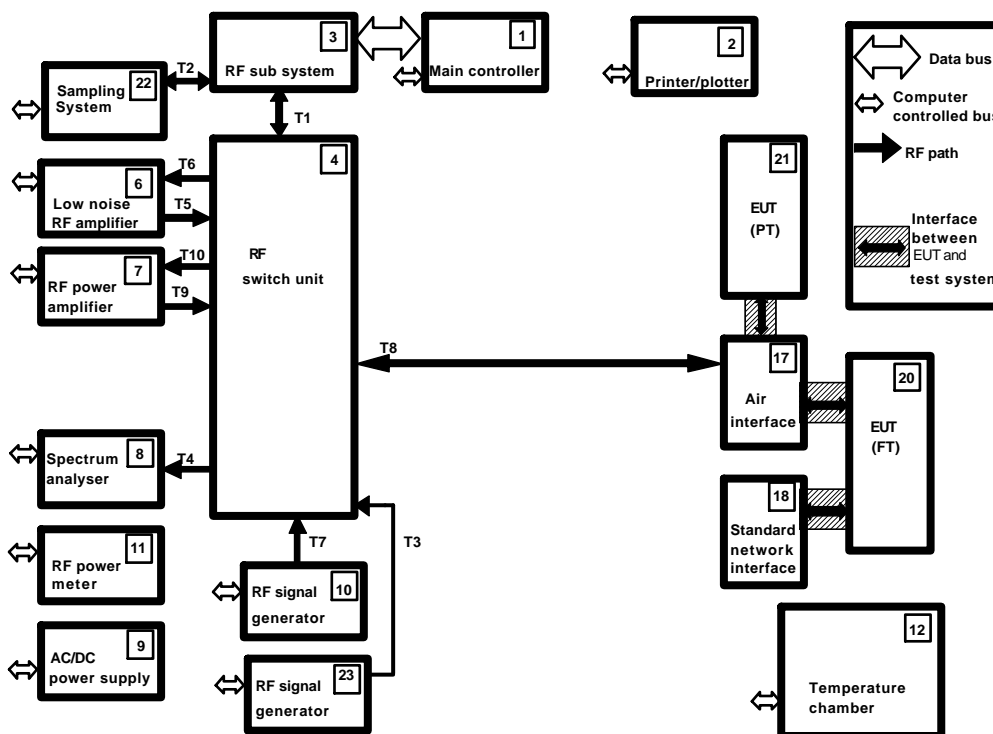

Figure 9: Functional Contents of the LT

### 5.8.2 Connections between the EUT and the LT

This is specified in each test case.

### 5.8.3 Functions and abilities

The LT shall include all the functions necessary to perform the tests described in this TBR.

These include the ability to:

- generate one actual DECT RF signal;
- generate one modulated DECT-like carrier;
- generate CW interferer(s);
- sample and store an accurate representation of the EUT's RF signal;
- transmit a variety of test data sequences in the B-field;
- transmit on more than one slot per frame;
- make measurements as described in this TBR according to the uncertainties described in subclause 5.8.5;
- emulate a DECT FT, with the possibility to programme all DECT identity codes;
- emulate a DECT PT, with the possibility to programme all DECT identity codes.

### 5.8.4 Signal generation uncertainty

Carrier frequency:  $\pm 5$  kHz.

#### 5.8.4.1 Modulated DECT-like carrier

This is a RF carrier using gaussian shaped frequency-shift keying ( $BT = 0,5$ ) modulated with a 1 152 kbit/s pseudo-random sequence with minimum length  $2^9-1$ . If the signal is bursted, it is required that the burst is synchronised to the DECT test signal generated by the LT.

#### 5.8.4.2 CW interferers

The uncertainty shall be determined by the overall bit error ratio measurement uncertainty of a test case. This is specified in subclause 5.8.5.

#### 5.8.4.3 DECT RF Signal

The carrier is defined using the method of subclause 7.3 and it shall meet the requirements needed to fulfil measurement uncertainties of subclause 5.8.5.

#### 5.8.4.4 Test modulation signals

The test modulating signal is a baseband signal which modulates a carrier and is dependent upon the type of equipment under test and also the measurement to be performed.

Signals for data (bit stream):

- D-M2: A signal representing a pseudo-random bit sequence of at least 511 bits in accordance with CCITT Recommendation O.153 [10]. This sequence shall be continuously repeated. This signal shall be used as a wanted signal.

### 5.8.5 Measurement uncertainty

The following values of measurement uncertainty associated with each measurement parameter apply to all of the test cases described in this TBR.

### 5.8.5.1 RF measurements

Relative drift radio frequency:	$\pm 2$ kHz
Absolute radio frequency:	$\pm 10$ kHz
Relative radio frequency:	$\pm 5$ kHz
Conducted emissions:	$\pm 1$ dB
Radiated emissions:	$\pm 3$ dB
Maximum frequency deviation:	$\pm 5$ kHz
Absolute RF power (via an antenna connector):	$\pm 1$ dB
Absolute RF power (for unwanted emissions in the DECT band):	$\pm 4$ dB
Absolute RF power (for unwanted emissions outside the DECT band):	
conducted:	$\pm 4$ dB;
radiated:	$\pm 6$ dB
Relative RF power:	$\pm 1$ dB
Absolute RF power (radiated):	$\pm 3$ dB
Relative Packet timing:	$\pm 0,1$ $\mu$ s
Absolute Packet timing:	$\pm 1$ $\mu$ s
Timing stability of FT:	1 ppm
Bit error ratio:	$\pm 5$ % (of the measured value)
Transmitter burst transient time:	$\pm 20$ % (of the measured value)
Peak frequency deviation	$\pm 10$ kHz

NOTE: All figures reflect a 95 % confidence level.

## 5.9 Upper Tester (UT)

### 5.9.1 Description of the UT

The UT is part of, but not necessarily restricted to, the EUT. For the purpose of testing, an EUT capable of transmitting shall recognise a mandatory set of test commands sent by the LT. The ability to recognise and implement the commands is contained in the UT which is resident in the MAC layer as described in ETS 300 175-3 [3], and as defined by clause 18 of this TBR. All DECT equipment shall be capable of recognising these commands. An EUT which is declared as implementing the TSP shall implement the provisions of the TSP described in annex D. The implementation of the TSP is not mandatory.

### 5.9.2 The test standby mode

Accessibility to these messages is controlled by some means of mechanical interlocking method or manual switching (e.g. dip-switch, jumper, prom, or key-pad code as designated by the applicant) to prevent accidental execution of these messages in a DECT user environment.

When the EUT has been switched into a mode whereby the test messages are accessible, the EUT is said to be in the test standby mode.

### 5.9.3 Test messages

The MAC layer test messages provide the following functions:

- instruct the EUT to transmit on a LT-specified physical channel. The test message also determines whether the handover function of the EUT (if so equipped) is disabled and if previous bearers are to be maintained. See subclauses 7.2.5.4.2 and 12.3 of ETS 300 175-3 [3];
- instruct the EUT to perform the loopback function in which a test data pattern transmitted by the LT is replicated in the reply transmission of the EUT. The test data pattern is a bit sequence located in the D-fields of the LT and EUT. The bits of the D-field that are affected by the loopback function depends on the equipment type and are as follows:

<u>Equipment type</u>	<u>Loopback Bits</u>
Transmits only A-field:	$a_{16}$ to $a_{47}$ ;
Transmits half-slots:	$b_0$ to $b_{79}$ ;
Transmits full-slots:	$b_0$ to $b_{319}$ ;
Transmits double-slots:	$b_0$ to $b_{799}$ .

Equipment capable of transmitting more than one slot type shall use the longest slot type for this test message (see subclauses 7.2.5.4.3 and 12.4 of ETS 300 175-3 [3]).

- c) defeat antenna diversity and select the specified antenna for operation in those EUTs possessing antenna diversity (see subclauses 7.2.5.4.4 and 12.5 of ETS 300 175-3 [3]);
- d) initiate the bearer handover procedure resident in an EUT that is declared by the applicant as possessing bearer handover capability (see subclauses 7.2.5.4.5 and 12.6 of ETS 300 175-3 [3]);
- e) permit inclusion of proprietary test messages by means of the "escape" code (see subclauses 7.2.5.4.6 and 12.8 of ETS 300 175-3 [3]);
- f) pass test messages (when applicable) to the network layer of the EUT (see subclauses 7.2.5.4.7 and 12.7 of ETS 300 175-3 [3]);
- g) provide for a means to reset the test state of the EUT by means of the "clear test modes" message (see subclauses 7.2.5.4.8 and 12.9 of ETS 300 175-3 [3]).

## 5.10 Description of the lower tester FT and PT

The lower tester FT and PT are systems consisting of the RF equipment, controller(s), software, and other related components necessary to be capable of implementing all the functions defined in the DECT specification documents.

## 5.11 General test methods

### 5.11.1 General

It is recognised that for some parameters alternative test methods may exist. It is the responsibility of the test laboratory to ensure that any alternative test method used yields results identical to those described in this TBR.

### 5.11.2 Sampling the RF signal

#### 5.11.2.1 Introduction

A number of tests in this TBR require the RF signal to be sampled and demodulated. The following text describes the sampling method that should be performed in the LT.

**5.11.2.2 Sampling method** The equipment under test shall be connected to the LT. This connection shall be direct for an EUT having an antenna connector or via an antenna coupling device for an EUT with an integral antenna and not having means of connecting an external antenna, unless otherwise specified in this TBR.

Handover (if available) shall be disabled in the EUT while the sampling takes place (see subclause 5.9.3 for the appropriate test message reference).

Antenna diversity (if available) shall be disabled in the EUT while the sampling takes place (see subclause 5.9.3 for the appropriate test message reference).

Using a sampling measurement method, capture a representation of the EUT's transmitted RF signal. The position in a physical packet shall be calculated using the samples from the physical packet, knowing the received bit pattern. These calculated bit positions shall be used as the time reference when making measurements of RF frequency, phase and power.

NOTE: When reference is made to  $p_0$  in this TBR, for example, it is intended that its position is calculated using many samples of a physical packet. The frequency, power or phase at this theoretical position of  $p_0$  can then be measured.



### 5.11.3 Determining the reference position

During many tests the EUT is required to be oriented specifically in relation to the test antenna connected to the LT.

This position is called the reference position and is defined in the following paragraphs.

#### 5.11.3.1 Case 1: EUTs that cannot transmit

If the EUT has only an integral antenna then the applicant shall inform the test laboratory of the orientation of the integral antenna.

#### 5.11.3.2 Case 2: EUTs that can transmit

The EUT shall be placed in a mode whereby it is transmitting.

NOTE: For most tests the EUT will have already been placed in a transmission mode.

The EUT shall be rotated in both horizontal and vertical planes in order to locate the direction of maximum field strength that is detected by the test antenna. This orientation shall be called the reference position.

### 5.11.4 Bit Error Rate (BER) measurements

BER measurements are carried out by comparing data in the loop back field transmitted by the LT with data in the loop back field received from the EUT (which is in loop back mode).

If the EUT does not recognise the sync word of the frame transmitted by the LT and therefore is unable to loop back any data, this frame shall be disregarded from the BER measurement (refer to annex E and annex F).

## 5.12 Test set-up

Test set-ups have been defined according to ISO Publication 9646-1 [8]. The test cases listed in table 3 have an associated test set-up.

The numbers inside the figures shown in subclauses 5.12.1 to 5.12.5 refer to functional blocks inside the LT. These are shown in figure 9 in subclause 5.8.1.

### 5.12.1 Test set-up 1

For the test set-up depicted in figure 10, the following test cases apply:

Test Cases: 1, 2, 3, 4, 5, 6, 7, 8, 14, and 15.

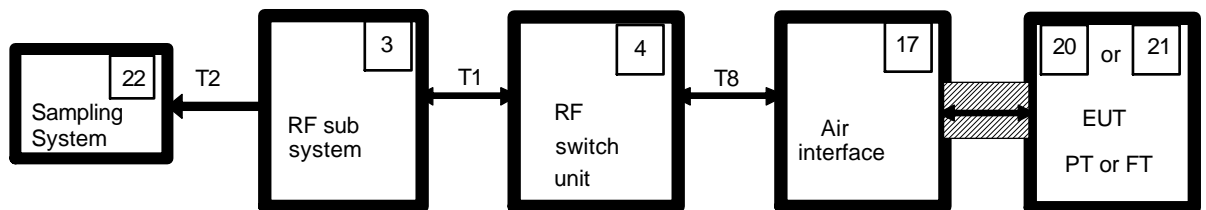

Figure 10: Test set-up 1

5.12.2 Test set-up 2

For the test set-up depicted in figure 11, the following test cases apply:

Test Cases: 16 and 18.

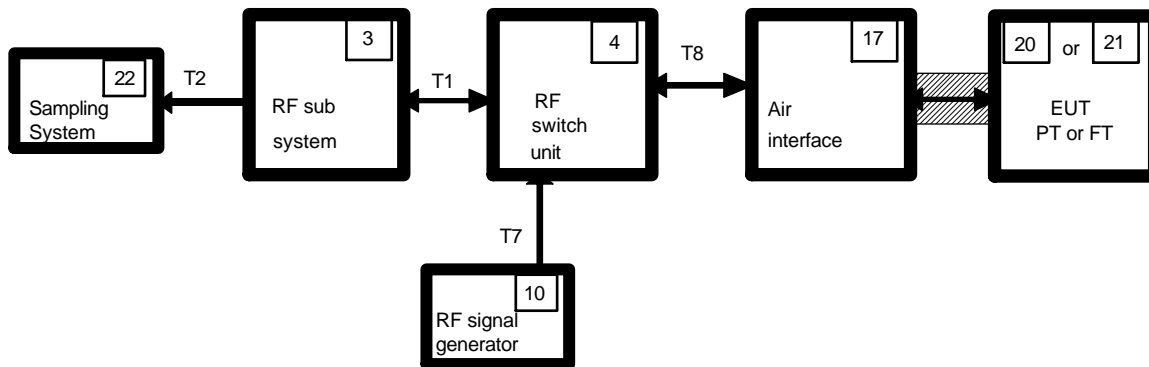

Figure 11: Test set-up 2

5.12.3 Test set-up 3

For the test set-up depicted in figure 12, the following test case applies:

Test Case: 19.

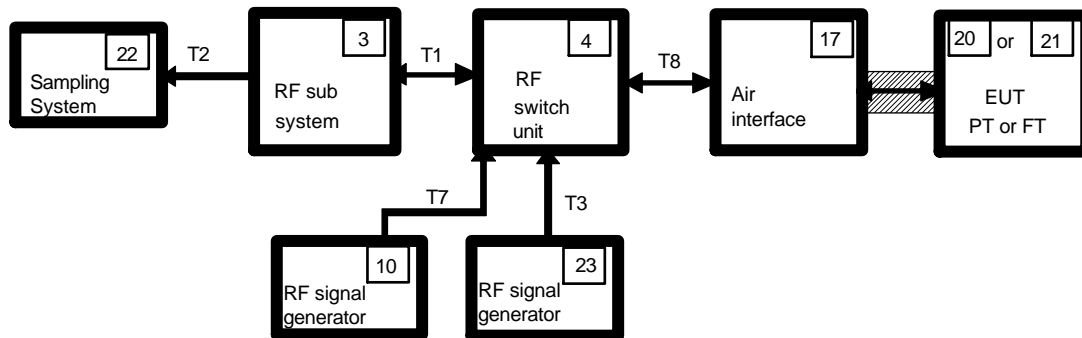

Figure 12: Test set-up 3

5.12.4 Test set-up 4

For the test set-up depicted in figure 13, the following test cases apply:

Test Cases: 9, 10, 11, 12, 13, and 20.

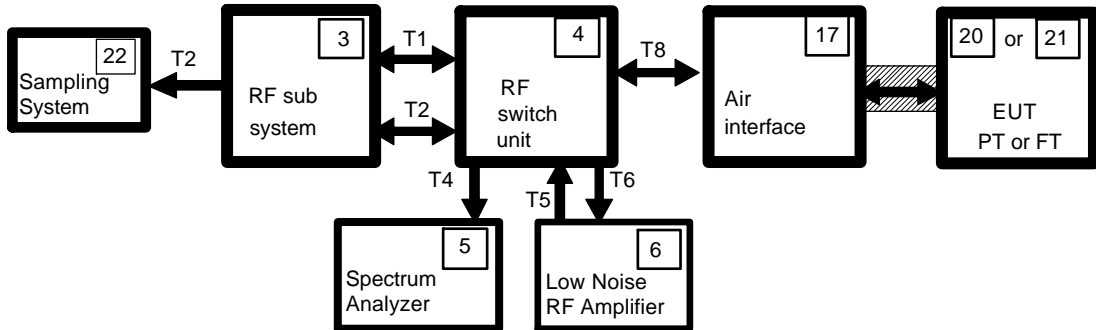

Figure 13: Test set-up 4

5.12.5 Test set-up 5

For the test set-up depicted in figure 14, the following test case applies:

Test Case: 17.

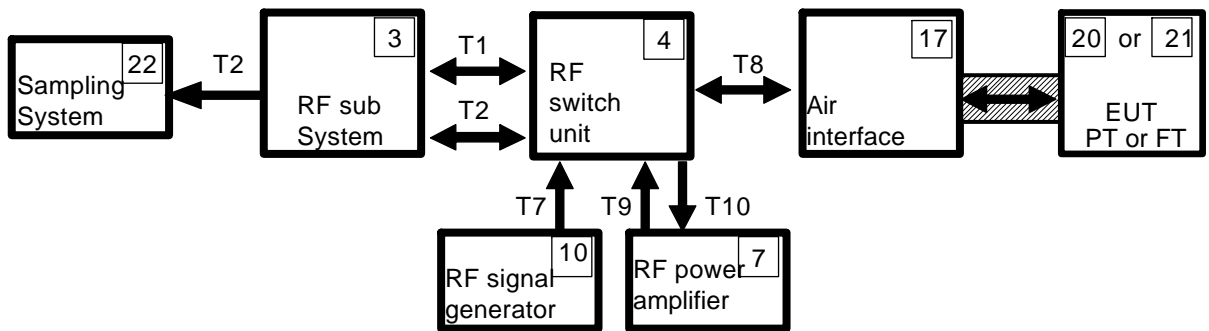

Figure 14: Test set-up 5

### 5.13 Test arrangements for intermodulation measurements

#### 5.13.1 PT to PT arrangement

In the PT to PT situation, the minimum distance for non-interference operation is specified as being 0,5 m. Figure 5 shows the testing arrangement:

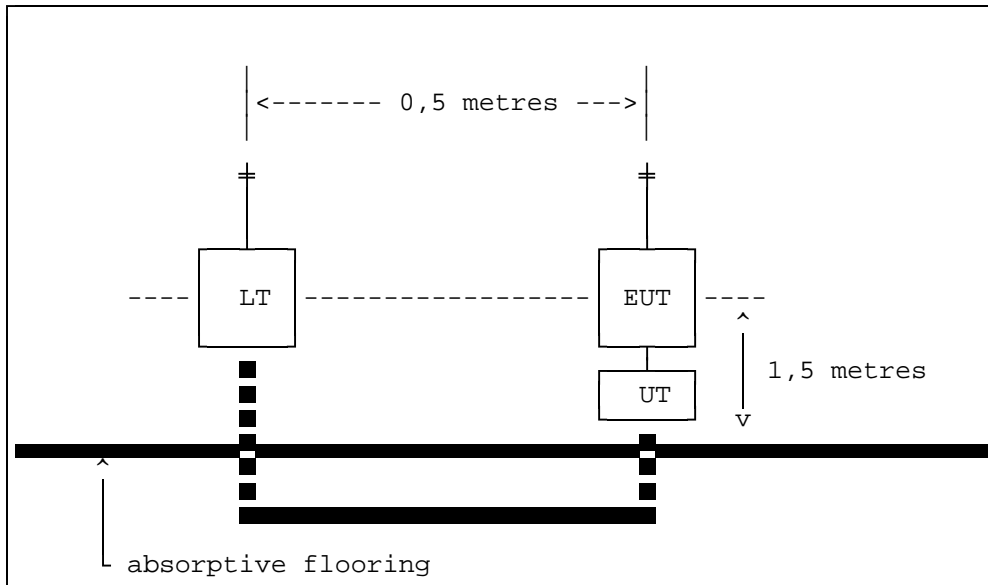

Figure 15

The elevation of the antennas are the same. Absorptive flooring is used to minimise reflection effects. The link between the UT and the EUT indicates the control of the EUT via the DECT air interface.

#### 5.13.2 FT to FT arrangement

In the FT to FT situation, the minimum distance for non-interference operation is specified as being 1,0 m. Figure 16 shows the testing arrangement:

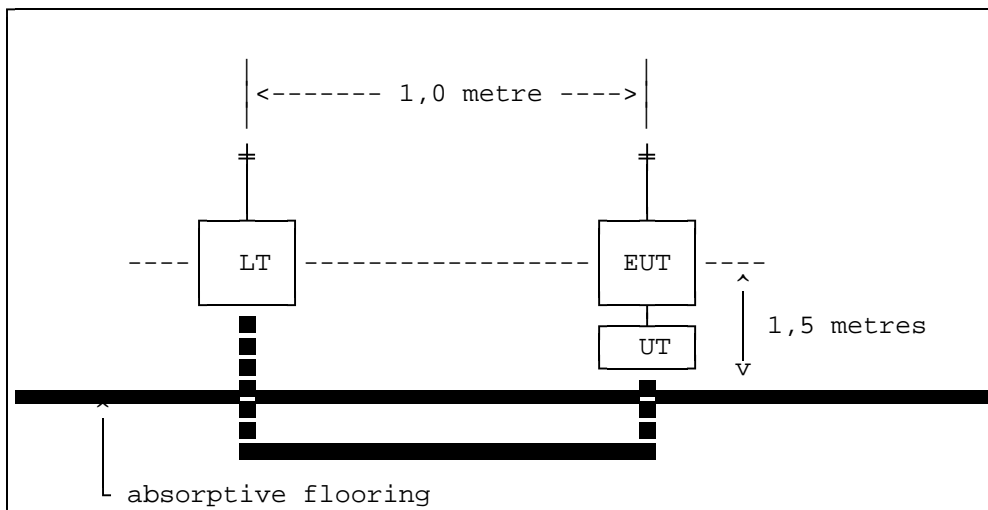

Figure 16

The elevation of the antennas are the same. Absorptive flooring is used to minimise reflection effects. The link between the UT and the EUT indicates the control of the EUT via the DECT air interface.

### 5.13.3 FT to PT arrangement

In the FT to PT situation, the minimum distance for non-interference operation is specified as being 1,0 m. Figure 17 shows the testing arrangement:

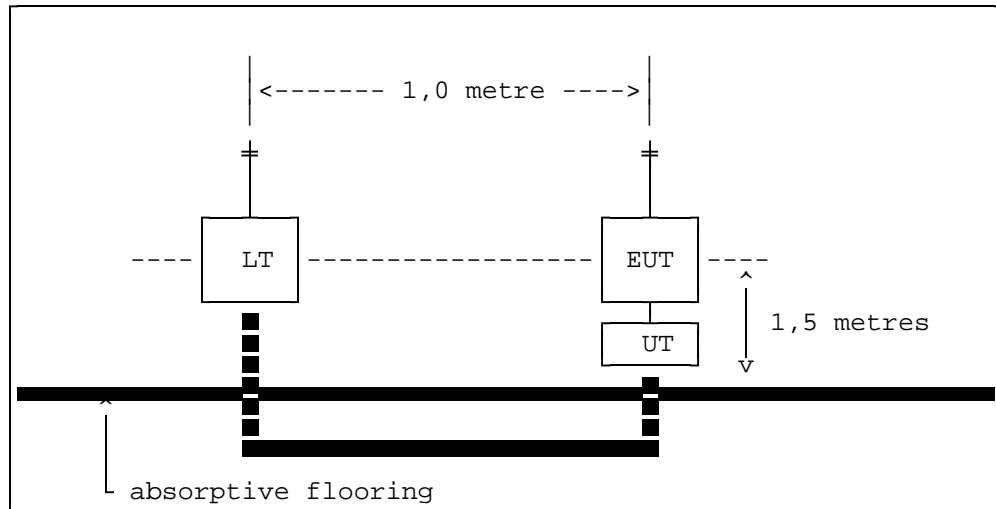

Figure 17

The elevation of the antennas are the same. Absorptive flooring is used to minimise reflection effects. The link between the UT and the EUT indicates the control of the EUT via the DECT air interface.

## 6 Test conditions, power sources and ambient temperatures

### 6.1 General

The following conditions shall apply during all tests:

Temperature uncertainty:	$\pm 1$ °C;
Atmospheric pressure:	86 to 106 kPa;
Relative humidity:	20 % to 75 % non-condensing;
Humidity uncertainty:	$\pm 10$ %.

The temperature conditions and voltage supply applied in each test are specified as either nominal or extreme. The definitions of nominal and extreme are contained in subclauses 6.2 and 6.3. Each test case defines whether nominal or extreme conditions apply. In some test cases only extreme temperature conditions apply and this is stated in the appropriate test case.

Before measurements are made, the equipment shall have reached thermal equilibrium in the test chamber. The equipment shall be switched off during the temperature stabilising period. If the thermal equilibrium is not checked by measurements, a temperature stabilizing period of at least one hour, or such period as may be decided by the test laboratory, shall be allowed.

Before the start of a test, but after reaching thermal equilibrium in the test chamber, the equipment shall be powered up. For RFPs, the time between power-up and the start of testing shall be greater than 15 minutes. For PPs, testing may commence any time after 1 minute has elapsed after power-up.

The sequence of measurements shall be chosen, and the humidity content in the test chamber shall be controlled, so that condensation does not occur.

It is not necessary to control the atmospheric pressure during testing.

When it is impractical to carry out the tests under these conditions, a statement giving the actual temperature and relative humidity during the tests shall be recorded in the test report.

**6.2 Nominal test conditions**

These are identical for all types and classes of equipment. This is clarified by the following three figures.

PP

	VOLTAGE		
	MIN	NOM	MAX
0 °			
+15-35 °			
+40 °			

**Figure 18**

FP, RFP, CCFP for Class E1 use

	VOLTAGE		
	MIN	NOM	MAX
+10 °			
+15-35 °			
+40 °			

**Figure 19**

FP, RFP, CCFP for Class E2 use

	VOLTAGE		
	MIN	NOM	MAX
-10 °			
+15-35 °			
+55 °			

**Figure 20**

For nominal temperature, each measurement is made at the temperature of the test site, which shall be within + 15 to + 35 °C.

**6.3 Extreme test conditions**

The extreme test conditions are determined by the type of equipment under test. The following three figures class the EUT as either PP, FP, RFP or CCFP. See subclause 3.2 for definitions.

In addition, FPs, RFPs and CCFPs shall be classed as either for Class E1 use or Class E2 use. Class E1 use refers to indoor areas allowing for personal comfort, for example, homes, offices, laboratories or workshops. Class E2 use refers to all other areas.

For the extreme temperature ranges of - 10, 0, 10 and 40 °C, measurements shall be made at the specified temperature with a tolerance of ± 1 °C.

The definitions of minimum, nominal and maximum applied voltage are contained in subclauses 6.5 and 6.6.

PP

	VOLTAGE		
	MIN	NOM	MAX
0 °	■		■
+15-35 °		■	
+40 °	■		■

Figure 21

FP, RFP, CCFP for Class E1 use

	VOLTAGE		
	MIN	NOM	MAX
+10 °	■		■
+15-35 °		■	
+40 °	■		■

Figure 22

FP, RFP, CCFP for Class E2 use

	VOLTAGE		
	MIN	NOM	MAX
-10 °	■		■
+15-35 °		■	
+55 °	■		■

Figure 23

## 6.4 Test power source - general requirements

During the type tests, the power source of the equipment shall be replaced by a test power source, capable of producing normal and extreme test voltages as specified in subclauses 6.5 and 6.6. The internal impedance of the test power source shall be low enough for its effect on the test results to be negligible. For the test purposes, the voltage of the power source shall be measured at the input terminals of the equipment.

If the equipment is provided with a permanently connected power cable, the test voltage shall be measured at the point of connection of the power cable to the equipment.

In equipment with incorporated batteries, the test power source shall be applied as close to the battery terminals as is practical. In each case connections must be made readily available by the applicant.

During tests, the power source voltages shall be maintained within a tolerance of  $\pm 3\%$  relative to the voltage at the beginning of each test.

## 6.5 Nominal test power source

### 6.5.1 Mains voltage

The normal test voltage for equipment to be connected to the mains shall be the nominal mains voltage. For the purpose of this specification, the nominal voltage shall be the voltage or voltages for which the equipment was designed as declared by the applicant. The frequency of the test power source corresponding to the ac mains shall be between 49 and 51 Hz.

### **6.5.2 Regulated lead acid battery power sources**

When the radio equipment is intended for operation from a lead-acid chemistry battery source, the source voltage used during testing shall be 1,1 times the nominal voltage of the battery (i.e.  $1,1 \times \text{number of cells} \times 2\text{V/cell}$ ).

### **6.5.3 Nickel cadmium battery**

When the equipment is intended for operation from a nickel-cadmium chemistry battery source, the source voltage used during testing shall be the nominal voltage of the battery (1,2 volt per cell).

### **6.5.4 Other power sources**

For operation from other power sources or types of battery, either primary or secondary, the normal test source voltage shall be that declared by the applicant.

## **6.6 Extreme test power source**

### **6.6.1 Mains voltage**

The extreme test source voltages for equipment to be connected to an ac mains source shall be the nominal mains voltage  $\pm 10\%$ . The frequency of the test power source shall be between 49 and 51 Hz.

### **6.6.2 Regulated lead acid battery power sources**

When the equipment is intended for operation from the usual type of regulated lead acid battery source, the extreme test voltages shall be 1,3 and 0,9 times the nominal voltage of the battery.

### **6.6.3 Nickel cadmium battery**

When the equipment is intended for operation from the usual type of nickel cadmium battery, the extreme test voltages shall be 1,25 and 0,9 times the nominal voltage of the battery.

### **6.6.4 Other power sources**

The lower extreme test voltage for equipment with power sources using primary batteries shall be as follows:

- a) for Leclanché type of battery - 0,85 times the nominal voltage;
- b) for other types of primary battery - the end point voltage declared by the applicant.

The upper extreme test voltage shall be the nominal voltage of the battery.

For equipment using other power sources, or capable of being operated from a variety of power sources, or designed for operation within extreme voltage limits not in accordance with those quoted above the extreme test voltages shall be those agreed between the applicant and the test laboratory and shall be recorded with the test results.

## **6.7 Testing of host connected equipment and plug-in cards**

For equipment for which connection to or integration with host equipment is required to offer functionality, two alternative approaches are permitted. The applicant shall declare which alternative shall be used.



### 6.7.1 Alternative A: composite equipment

A combination of a DECT radio equipment part and a specific type of host equipment may be used for testing according to this TBR.

Where more than one such a combination is intended, each combination shall be tested separately.

In case a specific combination of host and DECT radio equipment part is tested as a composite system for type approval, it is expected that testing shall not be repeated for those other combinations of hosts and DECT radio equipment parts which are based on substantially similar host models on the condition that the variations in mechanical and electrical properties between such host models are unlikely to have any significantly different influence on the radio characteristics of the DECT radio equipment part and providing that the radio module cannot be used without electrical, mechanical or software modifications in variations of hosts different from those represented by the units used for the type examination.

### 6.7.2 Alternative B: use of a test jig and three hosts

Where the DECT radio equipment part is intended for use with a variety of host systems, the applicant shall supply a suitable test jig. The test jig shall be designed such that alteration of the DECT radio equipment's intrinsic emissions is minimized. Where connection between the DECT radio equipment part and the host is by means of cables, optical fibres or similar means between control and/or power ports, the connection to the host shall be considered a suitable test jig.

The test jig shall allow the DECT radio equipment part to be powered and stimulated in a way similar to the way it would be powered and stimulated when connected to or inserted into host equipment.

In addition to tests on the test jig, the DECT radio equipment part shall be tested according to subclauses 10.2, 12.2, 12.5.2 and 13.7 if the equipment is provided with an integral antenna, or subclauses 10.3, 12.2, 12.5.3 and 13.7 if the equipment is provided with an antenna connector; when connected to or inserted into three different hosts. These hosts shall be provided by the applicant and shall be selected from the list of compatible hosts as published by the applicant as part of the user documentation supplied with the radio equipment part. The selection of hosts shall be agreed to by the Notified Body. National regulatory administrations shall have the discretion to require the applicant to inform them of each deletion from or addition to the list of compatible hosts as published in the user documentation.

For those tests required by the previous paragraph, with the DECT radio equipment part to be connected to or inserted in host equipment, the combination shall be tested against the requirements of this TBR except for cabinet radiation from the enclosure which only in these specific tests shall be measured according to the requirements that apply to the host equipment. When the host equipment is Information Technology Equipment (ITE), the requirements of EN 55022 class B [12] apply.

## 7 Accuracy and stability of RF carriers

The requirements are given in subclause 4.1.2 of ETS 300 175-2 [2].

### 7.1 Definition

The ten RF carriers allocated to the DECT service are given by:

$$F_c = F_0 - c * 1\,728 \text{ kHz}, c = 0, 1, \dots, 9;$$

where  $F_0 = 1\,897,344 \text{ MHz}$ .

### 7.2 Test environment

The test shall take place at a test site or in a test fixture.

If the EUT has an antenna connector then it shall be used to connect the EUT to the LT.

The test shall take place under extreme test conditions.

### 7.3 Method of measurement

- a) The LT shall place the EUT in a mode whereby the EUT is positioned in a LT specified slot and RF channel  $c = 5$ . If so equipped, the handover function in the EUT shall be disabled. See subclause 5.9.3 for the appropriate test message reference;
- b) the EUT shall be placed in a test mode whereby it performs the loopback function as referenced in subclause 5.9.3;
- c) the LT shall transmit a packet with a test sequence in the loopback field of the packet. This test sequence shall be such that the sequence 0000111100001111.... is transmitted at the antenna of the EUT in the loopback field of the reply packet;
- d) using the sampling method described in subclause 5.11.2.2 of this TBR, capture a representation of the EUT's transmitted RF signal after allowing the EUT to be in an active-locked state (see ETS 300 175-3 [3]) for more than 1 s;
- e) the EUT's carrier frequency for part d) shall be assumed to be the average of the measured absolute frequencies of the loopback bits;
- f) parts c) to e) shall be repeated until the following number of measurements have been made:

<u>Equipment type</u>	<u>Number of measurements</u>
A-field only transmit	100
Half-slot transmit	40
Full-slot transmit	10
Double-slot transmit	5

The center frequency of the EUT is taken to be the mean value of the measurements.

- g) parts c) to f) shall be repeated for all combinations of temperatures and power supply voltages allowed under extreme test conditions;
- h) parts c) to g) shall be repeated for RF channels  $c = 0$  and 9;
- i) when the EUT is a PP, then parts c) to h) shall be repeated, with the addition that the RF signal is sampled (in part d)) during the first 1 s of the EUT going into a transmit mode from a non-transmitting mode. If necessary parts a) and b) may be repeated as required in order to make the number of measurements specified in part f).

### 7.4 Verdict criteria when the EUT is a RFP

The carrier frequencies as measured shall be within  $\pm 50$  kHz of the appropriate nominal DECT carrier frequency  $F_c$ .

### 7.5 Verdict criteria when the EUT is a PP

#### 7.5.1 Case 1: When the measurement is made during the first 1 s of the EUT going into a transmit mode from a non-transmitting mode

The carrier frequencies as measured either relative to an absolute frequency reference or relative to the received carrier, shall be within  $\pm 100$  kHz of the nominal DECT carrier frequency  $F_c$ .

#### 7.5.2 Case 2: When the measurement is made at any other time

The carrier frequencies as measured either relative to an absolute frequency reference or relative to the received carrier, shall be within  $\pm 50$  kHz of the nominal DECT carrier frequency  $F_c$ .

## 8 Accuracy and stability of timing parameters

The requirements are given in subclauses 4.2.2, 4.2.3 and 4.2.4 of ETS 300 175-2 [2].

### 8.1 Slot structure definitions

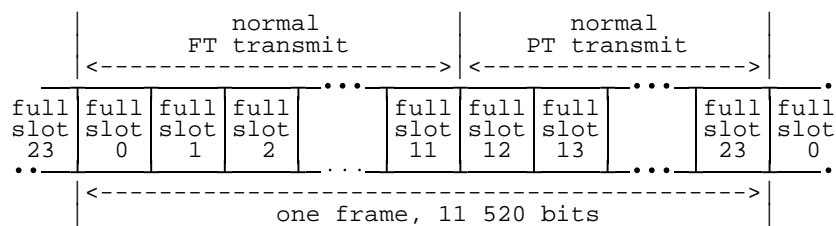

**Figure 24: Frame and full-slot structure**

Full-slots "K" are numbered from 0 to 23, and half-slots "L" are numbered 0 or 1, where half-slot 0 occurs earlier than half-slot 1. Normally full-slots  $K = 0$  to 11 are used in the FT to PT direction, while full-slots  $K = 12$  to 23 are normally used in the PT to FT direction.

Each full-slot has a duration of 480 bit intervals. Bit intervals within a full-slot are denoted  $f_0$  to  $f_{479}$  where interval  $f_0$  occurs earlier than interval  $f_1$ . Each half-slot has a duration of 240 bit intervals. Half-slots commence at  $f_0$  or  $f_{240}$  (see figure 25).

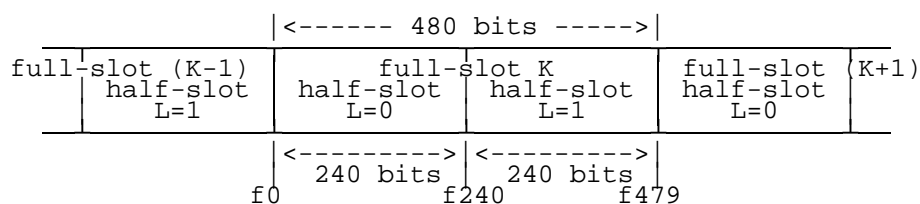

**Figure 25: Half-slot format**

Each double-slot has a duration of 960 bit intervals. Bit intervals within a double-slot are denoted  $f_0$  to  $f_{959}$ . Bits  $f_0$  to  $f_{479}$  coincide with the same notation for full-slots with even  $K$ ,  $K(e)$ .

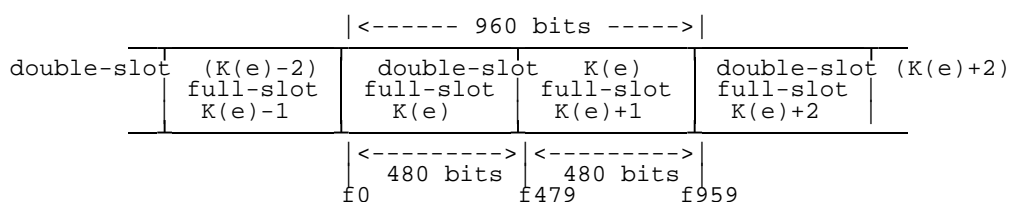

**Figure 26: high\_slotDouble-slot format**

### 8.2 Definition of the position of $p_0$

The start of bit  $p_0$  is defined to occur at the point in time 16 bit periods before the instant at which the modulated carrier passes through the nominal channel frequency immediately prior to the deviation corresponding to the first bit of the packet synchronisation word for the EUT as defined in subclause 4.6 of ETS 300 175-2 [2] for a PT or FT. A method shall be used for the determination of the position of the packet synchronisation word which meets the measurement uncertainty stated in subclause 5.8.5.1. It is not the point at which a receiver determines the presence of  $p_0$ .

### 8.3 Measurement of packet timing jitter

#### 8.3.1 Test environment

The test shall take place at a test site in a test fixture. If the EUT is equipped with a temporary connector, the temporary connector may be used in place of the test fixture for this test.

If the EUT has an antenna connector then it shall be used to connect the EUT to the LT.

The test shall take place under extreme test conditions.

#### 8.3.2 Method of measurement

- a) The LT shall place the EUT in a mode whereby the EUT is positioned in a LT specified slot and frequency. If so equipped, the handover function in the EUT shall be disabled. See subclause 5.9.3 for the appropriate test message reference.

The applicant shall declare to the testing laboratory the time required for system synchronization by the EUT;

- b) using a sampling method, capture a representation of the RF signal transmitted by the EUT on the same slot position in 2 consecutive frames;
- c) the LT shall determine the positions of p0 in the slots that were sampled in part c) above;
- d) parts c) and d) shall be repeated 1 000 times;
- e) the reference time is the mean of the values measured in parts c) through e). The deviation of the maximum and minimum values from the mean is the packet timing jitter.

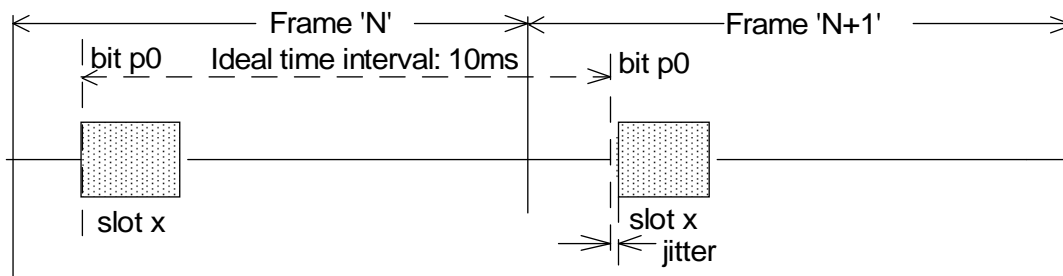

Figure 27

#### 8.3.3 Verdict criteria

The packet timing jitter, as measured, shall be less than  $\pm 1 \mu\text{s}$  for the duration of this test.

### 8.4 Measurement of the reference timing accuracy of a RFP

#### 8.4.1 Test environment

The test shall take place at a test site or in a test fixture. If the EUT is equipped with a temporary connector, the temporary connector may be used in place of the test fixture for this test.

If the EUT has an antenna connector then it shall be used to connect the EUT to the LT.

The test shall take place under extreme test conditions.

**8.4.2 Method of measurement**

- a) A minimum of one duplex bearer shall be set-up between the LT and the EUT;
- b) using a sampling method, measure the time,  $t_{long}$ , between the transmission of 1 000 frames using the same bit in each slot as the point of reference in each frame.

**8.4.3 Verdict criteria**

The EUT is required to conform to the following timing accuracies and stabilities at all the applied voltage conditions:

**Table 4: Reference timing accuracies and stabilities**

Type of EUT	Temperature	
	Nominal	Extreme
Multiple Channel RFP	5 ppm	10 ppm
Single Channel RFP	No Test	10 ppm

Table 5 indicates the range of values for  $t_{long}$  to which the EUT shall conform.

**Table 5: Allowable timing variations**

Timing Accuracy and Stability (ppm)	Ranges of $t_{long}$ Constituting a Pass (seconds)
5	$9,99995 < t_{long} < 10,00005$
10	$9,99990 < t_{long} < 10,00010$

RFPs that can work with more than one duplex pair of physical channels per frame are known as multi-channel RFPs. Single channel RFPs can only work with one duplex pair of physical channels per frame (excluding handover situations).

**8.5 Measurement of packet transmission accuracy of a PP**

**8.5.1 Test environment**

The test shall take place at a test site or in a test fixture. If the EUT is equipped with a temporary connector, the temporary connector may be used in place of the test fixture for this test.

If the EUT has an antenna connector then it shall be used to connect the EUT to the LT.

If the EUT has the facilities for advancing the transmission timing from the nominal then this shall be disabled for the duration of this test.

The test shall take place under extreme test conditions.

**8.5.2 Method of measurement**

- a) The LT shall place the EUT in a mode whereby the EUT is positioned in a LT specified slot and channel number  $c=5$ . If so equipped, the handover function in the EUT shall be disabled. See subclause 9.5.3 for the appropriate test message reference. The applicant shall declare to the testing laboratory the time required for a system synchronisation by the EUT;
- b) using a sampling method, capture a representation of the RF signal transmitted by the LT and EUT 12 slots apart in the same frame;

- c) the LT shall determine the positions at the EUT of p0 in the slots that were sampled in part b. above;
- d) the delay shall be calculated as the difference in time between the p0 of the LT and the p0 of the EUT;
- e) parts b) through to d) shall be repeated 100 times;
- f) parts b) through to e) shall be repeated for RF channels c=0 and 9;
- g) the minimum and maximum delays shall be found over all measurements.

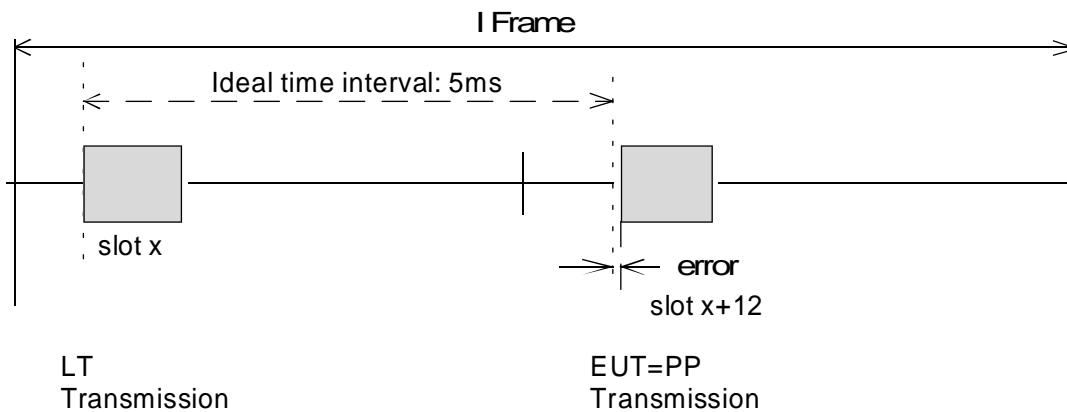

Figure 28

### 8.5.3 Verdict criteria

The packet timing delay minimum shall be greater than  $5\text{ms} - 2\ \mu\text{s}$ , the maximum shall be less than  $5\text{ms} + 2\ \mu\text{s}$ .

## 9 Transmission burst

The requirements are given in subclause 5.2 of ETS 300 175-2 [2].

### 9.1 Definitions

#### 9.1.1 Physical packets

The term "physical packet" used in this TBR refers to all the bits transmitted by the DECT radio endpoint in one slot time. The timing of the physical packet relative to the power-time template shall be conditioned by the absolute packet timing measurement uncertainty in subclause 5.8.5.1.

#### 9.1.2 Transmitted power

This is the mean power delivered over one radio frequency cycle.

#### 9.1.3 Normal Transmitted Power (NTP)

The NTP is the transmitted power averaged from the start of bit p0 of the physical packet to the end of the physical packet.

#### **9.1.4 Transmitter attack time**

This is the time taken for the transmitted power to increase from 25  $\mu$ W to the time that the first bit of the physical packet, p0, starts transmission.

The transmitter attack time shall be less than 10  $\mu$ s.

#### **9.1.5 Transmitter release time**

This is the time, taken from the end of the physical packet, for the transmitted power to decrease to 25  $\mu$ W.

The transmitter release time shall be less than 10  $\mu$ s.

#### **9.1.6 Minimum power**

From the first bit of the packet, p0, to the end of the physical packet, the transmitted power as measured shall be greater than (NTP - 1 dB).

#### **9.1.7 Maximum power**

From 10  $\mu$ s after the start of bit p0 to 10  $\mu$ s after the end of the physical packet the transmitted power as measured shall be less than (NTP + 1 dB).

From 10  $\mu$ s before the start of bit p0 to 10  $\mu$ s after the start of bit p0 the transmitted power as measured shall be less than (NTP + 4 dB), and shall be less than 315 mW plus the maximum allowed measurement uncertainty as described in subclause 5.8.5.

#### **9.1.8 Maintenance of transmission after packet end**

The transmitted power as measured shall be maintained greater than (NTP - 6 dB) for 0,5  $\mu$ s after the end of the physical packet.

#### **9.1.9 Transmitter idle power output**

For the time period starting 24  $\mu$ s after the end of the physical packet, and finishing 24  $\mu$ s before the next transmission of data bit p0, the transmitter idle power output shall be less than 20 nW plus the maximum allowed measurement uncertainty as described in subclause 5.8.5. This requirement shall apply except when p0 of the next transmitted packet occurs less than 54  $\mu$ s after the end of the transmitted physical packet.

### **9.2 Test environment**

If the EUT has an antenna connector then it shall be used to connect the EUT to the LT.

The test shall take place under nominal and extreme temperature conditions at the nominal supply voltage.

This test shall take place either at a test site, in an anechoic chamber, or in a test fixture for the nominal temperature condition. The extreme temperature testing shall take place inside a temperature chamber with the EUT mounted in a test fixture.

### **9.3 Method of measurement**

- a) The LT shall place the EUT in a mode whereby the EUT is transmitting at a LT specified slot and RF channel  $c = 5$ . If so equipped, the handover function in the EUT shall be disabled. See subclause 5.9.3 for the appropriate test message reference;
- b) using a sampling measurement method, capture a representation of the EUT's transmit burst's amplitude and modulation. The measurement bandwidth for RF power shall be 1MHz. See subclause 5.11.2.2;

- c) from the array of samples the LT shall calculate the position of bit p0 and the end of the physical packet in each sample to an accuracy of 0,1 μs;
- d) parts b) and c) are repeated 60 times with intervals of 1s or longer;
- e) parts a) to d) shall be repeated for RF channels c = 0 and 9.

**9.4 Verdict criteria**

The array of power samples shall be compared for a fit within the power-time template as shown in figure 29 and shall comply with the requirements in subclauses 9.1.4, 9.1.5, 9.1.6, 9.1.7, 9.1.8 and 9.1.9.

The sampled bursts, as measured, shall conform to the power-time template.

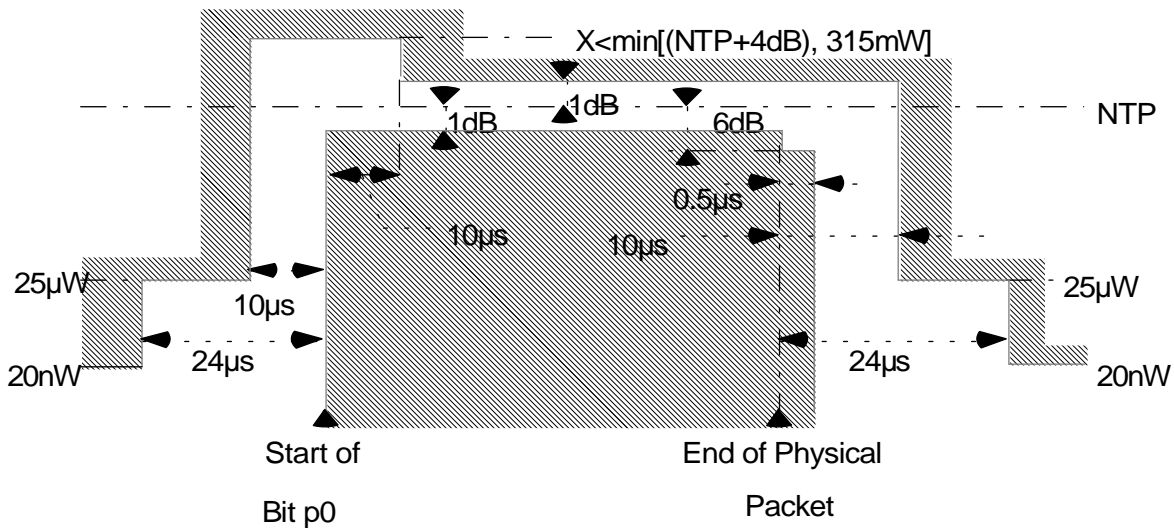

**Figure 29: Power-time template**

NOTE: As described in subclause 9.1.9, the 20 nW power envelope shown in figure 29 is only applicable when the time between the end of a physical packet and the transmission of p0 of the next physical packet is greater than 54 μs.

For packets with prolonged preamble, the verdict criteria apply with the notation p0 generally changed to p-16 and the applicant shall declare that the procedure defined in ETS 300 175-2 [2] Annex D, subclause D.3 has been implemented.

**10 Transmitted power**

The requirements are given in subclause 5.3 of ETS 300 175-2 [2].

**10.1 Definitions**

**10.1.1 PP and RFP with an integral antenna**

The equivalent isotropically radiated NTP shall be less than 250 mW per simultaneously active transceiver.

**10.1.2 PP and RFP with external connections for all antennas**

For a radio endpoint with more than one antenna port, the instantaneous power from each of antenna port shall be added together to give the NTP.

The NTP shall be less than 250 mW per simultaneously active transceiver.



### 10.1.3 PP and RFP with both integral and external antennas

If the integral and external antennas are not transmitting simultaneously then the test cases described in subclauses 10.2 and 10.3 shall be applied independently. The appropriate antenna is selected using the test message referenced in subclause 5.9.3.

If the integral and external antennas are transmitting simultaneously then the following test steps shall be applied:

- a) attach the external antenna(s) intended for normal use to the antenna connector(s);
- b) perform the test case as described in subclause 10.2.

## 10.2 PP and RFP with an integral antenna

### 10.2.1 Test environment

The test shall take place under nominal temperature conditions and at a nominal supply voltage.

This test shall take place either at a test site or in an anechoic chamber for the nominal temperature condition.

### 10.2.2 Method of measurement

- a) If the EUT incorporates antenna diversity, then the LT shall command the EUT to operate on a single antenna. See subclause 5.9.3 for the appropriate test message reference;
- b) the LT shall place the EUT in a mode whereby the EUT is positioned in a LT specified slot and frequency. If so equipped, the handover function in the EUT shall be disabled. See subclause 5.9.3 for the appropriate test message reference;
- c) a test antenna with a good directivity to limit reflections is connected to a calibrated receiver. The applicant shall indicate the polarisation of the integral antenna so that the test antenna can be set to the same polarisation as the integral antenna of the EUT throughout this test. The test antenna shall be raised or lowered until a maximum received signal is obtained;

The EUT shall be orientated in the reference position using the procedure described in subclause 5.11.3.

- d) at this position, the LT shall:
  - 1) use the sampling method described in subclause 5.11.2.2 of this TBR to capture a representation of a physical packet transmitted by the EUT;
  - 2) determine the position of p0 in the physical packet and the end of the physical packet;
  - 3) make a measurement of the received power over the 1 MHz bandwidth centred on the DECT RF channel. This power shall be averaged from the start of bit p0 to the end of the physical packet. This measurement shall be called  $P_R$ ;
- e) the substitution antenna shall replace the EUT's transmitter antenna in the same position and polarisation. The frequency of the signal generator shall be adjusted to the EUT's nominal channel frequency on which it was transmitting. The test antenna shall be raised or lowered as necessary to ensure that the maximum signal level is received. The input signal level to the substitution antenna shall be adjusted until an equal or a known related level to  $P_R$  is obtained in the test receiver.

$P_T$  is equal to the power supplied by the signal generator, increased by the known related level if necessary and after corrections due to the gain of the substitution antenna and the cable loss between the signal generator and the substitution antenna.

The equivalent isotropically radiated NTP is assumed to be equal to  $P_T$ ;

- f) parts b) to e) shall be performed for RF channels  $c = 0, 5, \text{ and } 9$ .

### 10.2.3 Verdict criteria for all EUTs

The NTP per simultaneously active transceiver, as measured, shall be less than 250 mW plus the maximum allowable measurement uncertainty as given in subclause 5.8.5.

## 10.3 PP and RFP with external antenna connection(s)

### 10.3.1 Test environment

The test shall take place under extreme temperature conditions and at a nominal supply voltage.

This test shall take place either at a test site or in an anechoic chamber for the nominal temperature condition. The extreme temperature testing shall take place inside a temperature chamber.

The EUT shall be connected to the LT via the antenna connector(s).

### 10.3.2 Method of measurement

- a) If the EUT incorporates antenna diversity, then the LT shall command the EUT to operate on a single external antenna. See subclause 5.9.3 for the appropriate test message reference;
- b) the LT shall place the EUT in a mode whereby the EUT is positioned in a LT specified slot and frequency. If so equipped, the handover function in the EUT shall be disabled. See subclause 5.9.3 for the appropriate test message reference;
- c) a test load shall be connected to each antenna connector;
- d) the LT shall:
  - 1) use the sampling method described in subclause 5.11.2.2 to capture a representation of a physical packet transmitted by one of the antenna connectors of the EUT into the test load;
  - 2) determine the position of  $p_0$  in the physical packet and the end of the physical packet;
  - 3) make a measurement of the power over the 1 MHz bandwidth centred on the DECT RF channel. This power shall be the power delivered to each load simultaneously, averaging from the start of bit  $p_0$  of the physical packet, to the end of the physical packet that was sampled in 1).
- e) parts b) to d) shall be performed for RF channels  $c = 0, 5, \text{ and } 9$ .

When there is more than one antenna port, the instantaneous power from each antenna port shall be added together. The sum shall be called the NTP.

### 10.3.3 Verdict criteria for all EUTs

The NTP per simultaneously active transceiver, as measured, shall be less than 250 mW plus the maximum allowable measurement uncertainty as given in subclause 5.8.5.

## 11 RF carrier modulation

The requirements are given in subclause 5.4 of ETS 300 175-2 [2].

### 11.1 Test environment

The test should preferably take place at a test site, otherwise a test fixture or temporary connector shall be used.

If the EUT has an antenna connector then it shall be used to connect the EUT to the LT.

The test shall take place under nominal supply voltage conditions and at a nominal temperature.

### 11.2 Method of measurement, Parts 1 and 2

The measurement period of a single positive or negative deviation measurement shall begin one bit time after a 0 to 1 or a 1 to 0 transition in the test data pattern. The measurement period shall end one bit time before the next 0 to 1 or 1 to 0 transition.

#### 11.2.1 Part 1

- a) Repeat parts a) to d) of subclause 7.3;
- b) using the samples that were obtained from part a) above, the LT shall calculate the peak frequency deviation within each bit period defined in 11.2 in the loopback field of the transmit burst of the EUT, relative to the measured carrier frequency that was calculated in clause 7 ;
- c) parts a) to b) shall be repeated until the following number of measurements have been made:

<u>Equipment type</u>	<u>Number of measurements</u>
A-field only transmit	100
Half-slot transmit	40
Full-slot transmit	10
Double-slot transmit	5

#### 11.2.2 Part 2

- a) Parts a) to d) of subclause 7.3 shall then be repeated using the appropriate sequence listed below:

<u>Equipment type</u>	<u>Test pattern</u>
A-field only transmit	figure 30
Half-slot transmit	figure 31
Full-slot transmit	figure 32
Double-slot	figure 33

- b) using the samples that were obtained from part (a) above, the LT shall calculate the peak frequency deviation within each bit period defined in 11.2 in the loopback field of the transmit burst of the EUT, relative to the measured carrier frequency that was calculated in clause 7;
- c) parts a) to b) shall be repeated until the following number of measurements have been made:

<u>Equipment type</u>	<u>Number of measurements</u>
A-field only transmit	100
Half-slot transmit	40
Full-slot transmit	10
Double-slot transmit	5

### 11.3 Method of measurement, Parts 3 and 4

The measurement period for the deviation measurement shall begin one bit time after the first 0 to 1 or 1 to 0 transition. The measurement period shall end one bit time before the last 0 to 1 or 1 to 0 transition.

**11.3.1 Part 3**

- a) Parts a) to d) of subclause 7.3 shall be repeated with the sequence "...0101010101010101....";
- b) using the samples that were obtained from part a) above, the LT shall calculate the peak frequency deviation within each bit period in the first 16 bits of the synchronisation field (preamble) and the loopback field of the transmit burst of the EUT, relative to the measured carrier frequency that was calculated in clause 7;
- c) parts a) to b) shall be repeated until the following number of measurements have been made:

<u>Equipment type</u>	<u>Number of measurements</u>
A-field only transmit	100
Half-slot transmit	40
Full-slot transmit	10
Double-slot transmit	5

**11.3.2 Part 4**

- a) The LT shall place the EUT in a mode whereby the EUT is positioned in a LT specified slot and frequency. If so equipped, the handover function in the EUT shall be disabled. See subclause 5.9.3 for the appropriate test message reference;
- b) the EUT shall be placed in a test mode whereby it performs the loopback function as referenced in subclause 5.9.3;
- c) the LT shall transmit a packet with a test sequence in the loopback field of the packet. This test sequence shall be such that the sequence 0101010101010101.... is transmitted at the antenna of the EUT in the loopback field of the reply packet;
- d) using the sampling method described in subclause 5.11.2.2 capture a representation of the EUT's transmitted RF signal after allowing the EUT to be in an Active-locked state (see ETS 300 175-3 [3]) for more than 1 s;
- e) using the samples that were obtained from part d) above, the LT shall calculate the average frequency of the last 14 bits of the first 16 bits of the synchronisation field;
- f) using the samples that were obtained from part d) above, the LT shall calculate the average frequency of the first 14 bits of the last 16 bits of the loopback field;
- g) parts c) to f) above shall be repeated until 200 measurements have been made. The frequency drift is the difference between the mean of the measurements taken in e) above and the mean of the measurements taken in f) above.

**11.4 Verdict criteria for part 1**

The peak frequency deviation as measured in part 1 shall be greater than  $\pm 259$  kHz and less than  $\pm 403$  kHz.

**11.5 Verdict criteria for part 2**

The peak frequency deviation as measured in part 2 shall be greater than  $\pm 202$  kHz and less than  $\pm 403$  kHz.

**11.6 Verdict criteria for part 3**

The peak frequency deviation as measured in part 3 shall be greater than  $\pm 202$  kHz and less than  $\pm 403$  kHz.

11.7 Verdict criteria for part 4

The rate of change as calculated in part 4 shall not be greater than 15 kHz per slot plus the maximum measurement uncertainty calculated from the allowable uncertainty in the relative drift radio frequency measurements involved (see subclause 5.8.5.1).

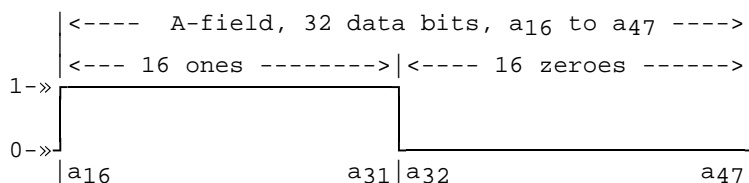
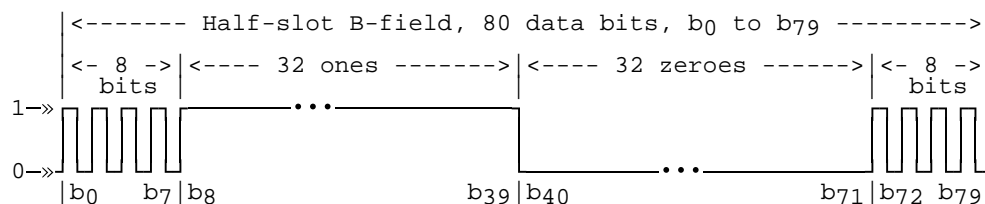
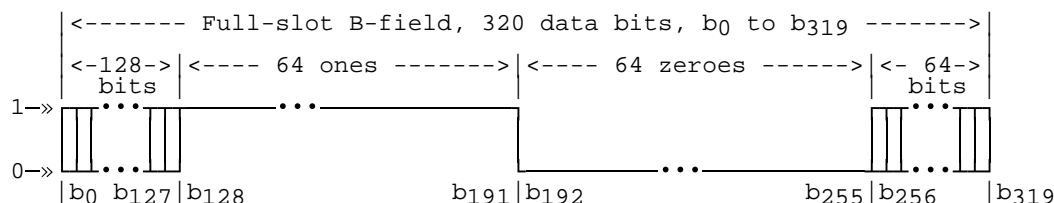

Figure 30: Test packet structure for Case 2, A-field



NOTE: Bits  $b_0$  to  $b_7$  and  $b_{72}$  to  $b_{79}$  are alternating 1s and 0s with the even order bits ( $b_0, b_2, b_4, \dots$ ) set to '1' and the odd-order bits ( $b_1, b_3, b_5, \dots$ ) set to '0'.

Figure 31: Test packet structure for case 2, half-slot



NOTE: Bits  $b_0$  to  $b_{127}$  and  $b_{256}$  to  $b_{319}$  are alternating 1s and 0s.

Figure 32: Test packet transmission for case 2, full-slot

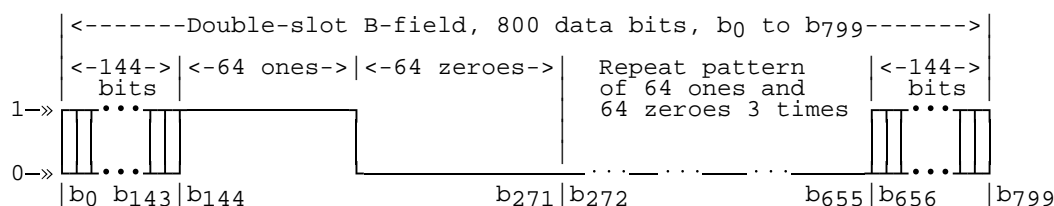

NOTE: Bits  $b_0$  to  $b_{143}$  and  $b_{656}$  to  $b_{799}$  are alternating 1s and 0s.

Figure 33: Test packet transmission for case 2, double-slot

NOTE: The above fields, (A-field for figure 30, half-slot for figure 31, full-slot for figure 32, and double-slot for figure 33) are defined in ETS 300 175-3 [3]. The X-field portions of the half-slot, full-slot, and double-slot B-fields depicted in figures 31, 32, and 33 are not shown.

## 12 Unwanted RF power radiation

### 12.1 General test conditions

If the EUT is equipped with antenna diversity, the EUT shall have the diversity operation defeated for these tests. See subclause 5.9.3 for the appropriate test message reference.

### 12.2 Emissions due to modulation

The requirements are given in subclause 5.5.1 of ETS 300 175-2 [2].

#### 12.2.1 Definition

The unwanted emission(s) due to modulation is the power measured in any DECT RF channel other than the one in which the EUT is transmitting, integrated over a bandwidth of 1 MHz.

#### 12.2.2 Test environment

The test shall take place at a test site or using a test fixture for equipment with integral antenna.

The test shall take place under nominal supply voltage conditions and at a nominal temperature.

#### 12.2.3 Method of measurement

- a) If the EUT has an external antenna connector then this shall be used to connect the EUT to the LT. Otherwise, the transmitted signal shall be applied to the LT via a coupling device which provides the appropriate signal level to the system. The analysing system in the LT shall be operated under the following conditions:

frequency sweep:	1 MHz;
resolution bandwidth:	100 kHz;
video bandwidth:	greater than resolution bandwidth;
integration:	across the frequency sweep;
peak hold:	on;
sweep time:	greater than 12 seconds;
filtering type:	synchronously tuned.

The centre frequencies of the DECT RF channels are defined in subclause 7.1.

The total sample time used for measurement is 60 to 80 percent of the duration of the physical packet, starting before 25% of the slot time has expired but after the transmission of the synchronisation word. The LT shall determine the start of the physical packet (bit p0) transmitted by the EUT;

- b) the LT shall place the EUT in a mode whereby the EUT is positioned in a LT specified slot and frequency. If so equipped, the handover function in the EUT shall be disabled. See subclause 5.9.3 for the appropriate test message reference;
- c) the EUT shall be placed in a test mode whereby it performs the loopback function as referenced in subclause 5.9.3;
- d) a test modulation signal D-M2 (see subclause 5.8.4.4) is generated by the LT;
- e) using the analysing system, a measurement of the EUT's transmitted power on channel M is made during the sampling time. This power measurement shall be called  $P_{ref}$ ;

NOTE: This measurement becomes the reference power for the power measurements of the other channels.

- f) using the method described in e), a measurement on all the other DECT channels shall be made and recorded in dB as a value relative to  $P_{ref}$ . These shall be called  $P_{rm-2}$ ,  $P_{rm-1}$ ,  $P_{rm+1}$ ,  $P_{rm+2}$ , etc., corresponding to the measurements made on channels  $Y = M-2$ ,  $Y = M-1$ ,  $Y = M+1$  and  $Y = M+2$ ;
- g) using the measured value of transmitted power, NTP, from clause 10 for channel  $Y = M$ , the LT shall calculate the power emissions on each channel. See the following example:

$$\begin{aligned} \text{Emissions on channel } Y = M + 1: \\ = \text{NTP(dBm)} + P_{rm+1}(\text{dB}); \end{aligned}$$

- h) the value calculated in g) shall be converted from dBm to Watts;
- i) steps b) through h) shall be performed with the EUT's transmitter placed on DECT RF channels  $c = 0, 5$ , and  $9$ .

#### 12.2.4 Verdict criteria

The unwanted emissions, as measured, shall not be greater than the power levels stated in table 6.

**Table 6**

Emissions on RF Channel "Y"	Maximum Power Level
$Y = M \pm 1$	160 $\mu\text{W}$
$Y = M \pm 2$	1 $\mu\text{W}$
$Y = \text{any other DECT channel}$	20 nW*

For  $Y = \text{"any other DECT channel"}$ , the maximum power level shall be less than 20 nW except for one instance of a 500 nW signal.

"M" is the EUT transmit channel and "Y" is a legal DECT channel other than the EUT transmit channel.

### 12.3 Emissions due to transmitter transients

The requirements are given in subclause 5.5.2 of ETS 300 175-2 [2].

#### 12.3.1 Definition

The power level of all modulation products (including AM components due to the switching on or off of the modulated RF carrier) in a DECT RF channel as a result of a transmission on another DECT RF channel.

#### 12.3.2 Test environment

The test shall take place at a test site or using a test fixture for equipment with integral antenna.

The test shall take place under nominal supply voltage conditions and at a nominal temperature.

**12.3.3 Method of measurement**

- a) If the EUT has an external antenna connector then this shall be used to connect the EUT to the LT. Otherwise, the transmitted signal shall be applied to the LT via a coupling device which provides the appropriate signal level to the system. The analysing system in the LT shall be operated under the following conditions:

frequency sweep:	1 MHz;
resolution bandwidth:	100 kHz;
video bandwidth:	greater than resolution bandwidth;
averaging:	none;
peak hold:	on;
filtering type:	4 or 5 pole synchronously tuned.

The centre frequencies of the DECT RF channels are defined in subclause 7.1.

- b) the LT shall place the EUT in a mode whereby the EUT is positioned in a LT specified slot and frequency. If so equipped, the handover function in the EUT shall be disabled. See subclause 5.9.3 for the appropriate test message reference;
- c) the EUT shall be placed in a test mode whereby it performs the loopback function as referenced in subclause 5.9.3;
- d) a test modulation signal D-M2 (see subclause 5.8.4.4) generated by the LT;
- e) the analysing system centre frequency is positioned at the centre of the DECT RF channel being measured;
- f) the analysing system shall initiate a power measurement procedure conforming to the limits specified in subclause 5.8.5;
- g) using the measured values obtained from parts e) to f), the LT shall select the highest recorded value. This value shall be compared with the verdict criteria;
- h) parts e) to g) are repeated for all DECT RF channels other than the one on which the EUT is transmitting;
- i) parts b) to h) shall then be repeated until measurements have been made with the EUT's transmitter placed on all 10 DECT RF channels.

**12.3.4 Verdict criteria**

The unwanted emissions, as measured, shall not be greater than the power levels stated in table 7.

**Table 7**

Emissions on RF channel "Y"	maximum peak power level
Y = M ± 1	250 µW
Y = M ± 2	40 µW
Y = M ± 3	4 µW
Y = any other DECT channel	1 µW

"M" is the EUT transmit channel and "Y" is a legal DECT channel other than the EUT transmit channel.

**12.4 Emissions due to intermodulation**

The requirements are given in subclause 5.5.3 of ETS 300 175-2 [2].



#### 12.4.1 Definition

The power level of intermodulation products that are on any DECT physical channel when any combination of the transmitters at a radio fixed part or portable part are in calls on the same slot on different frequencies.

#### 12.4.2 Test environment

If the EUT is a PP equipped with an integral antenna, the EUT and the test antenna shall be mounted in the reference test arrangement as specified in subclause 5.13.1.

If the EUT is a RFP with an integral antenna, the EUT and the test antenna shall be mounted in the reference testing arrangement as specified in subclause 5.13.2.

If the EUT has an external antenna connector then this test shall preferably take place at a test site, otherwise a test fixture may be used.

The test shall take place under nominal supply voltage conditions and at a nominal temperature.

#### 12.4.3 Method of measurement

- a) If the EUT has an external antenna connector then this shall be used to connect the EUT to the LT. Otherwise, the transmitted signal shall be applied to the LT via a coupling device which provides the appropriate signal level to the system. The analysing system in the LT shall be operated under the following conditions:

frequency sweep:	1 MHz;
resolution bandwidth:	100 kHz;
video bandwidth:	greater than resolution bandwidth;
integration:	across the frequency sweep;
peak hold:	on;
sweep time:	greater than 12 seconds;
filtering type:	synchronously tuned.

The centre frequencies of the DECT RF channels are defined in subclause 7.1.

The total sample time used for measurement is 60 to 80 percent of the duration of the physical packet, starting before 25% of the slot time has expired but after the transmission of the synchronisation word. The LT shall determine the start of the physical packet (bit p0) transmitted by the EUT;

- b) the EUT shall be placed in a mode whereby two of the transceivers shall be made to operate on the same slot in the frame but on different DECT RF channels. The RF channels shall be  $c = 0$  and  $c = 9$ . If so equipped, the handover function in the EUT shall be disabled. See subclause 5.9.3 for the appropriate test message reference;
- c) the EUT shall be placed in a test mode whereby it performs the loopback function for both transceivers as referenced in subclause 5.9.3;
- d) a test modulation signal D-M2 (see subclause 5.8.4.4) is generated by the LT;
- e) using the analysing system, a measurement of the transmitted powers on channels  $M = 0$  and  $M = 9$  shall be made during the sample time for a transmitter in the EUT. These measurements shall be called  $P_{\text{ref}0}$  and  $P_{\text{ref}9}$ ;
- f) the EUT shall be placed in a mode whereby two of the transmitters shall be made to operate on the same slot in the frame but on different DECT RF channels. The RF channels shall be  $M = 3$  and  $M = 6$ . If so equipped, the handover function in the EUT shall be disabled. See subclause 5.9.3 for the appropriate test message reference;

- g) using the analysing system, a measurement of the power levels on channels  $c = 0$  and  $c = 9$  shall be made during the sample time for a transmitter in the EUT. These power measurements shall be called  $P_{m0}$  and  $P_{m9}$ ;
- h) using the NTPs for  $c = 0$  and  $c = 9$  (as defined in clause 10), the LT shall calculate the power emissions on channels  $c = 0$  and  $c = 9$ . The calculation shall be performed as follows:
- 1) Emissions on channel 0 = :
 
$$= NTP_0(\text{dBm}) - P_{\text{ref}0}(\text{dBm}) + P_{m0}(\text{dBm}).$$
  - 2) Emissions on channel 9 = :
 
$$= NTP_9(\text{dBm}) - P_{\text{ref}9}(\text{dBm}) + P_{m9}(\text{dBm});$$
- i) parts b) to h) shall be repeated until measurements have been made with all combinations of the EUT's transmitters.

#### 12.4.4 Verdict criteria

The unwanted emissions due to intermodulation shall not be greater than  $1 \mu\text{W}$  as measured in the measurement channels.

#### 12.5 Spurious emissions when allocated a transmit channel

The requirements are given in subclause 5.5.4 of ETS 300 175-2 [2].

##### 12.5.1 Definition

The peak power level of any RF emissions outside the radio frequency band allocated to DECT when a radio endpoint has been allocated a transmit channel. If a radio endpoint has more than one transceiver, any out of band transmitter intermodulation products shall also be included.

##### 12.5.2 Radiated emissions

###### 12.5.2.1 Test environment

The test shall take place at a test site.

For EUTs with external antenna connectors, test loads shall be attached to each connector.

The test shall take place under nominal supply voltage conditions and at a nominal temperature.

###### 12.5.2.2 Method of measurement

- a) The analysing system in the LT shall be operated under the following conditions:

frequency sweep:	as required for frequency range;
resolution bandwidth:	refer to table below;
display bandwidth:	greater than resolution bandwidth;
averaging:	refer to table below;
peak hold:	refer to table below;
filtering type:	synchronously tuned.

The sweep time shall be chosen to be slow enough to ensure that the LT is capable of capturing at least one burst spurious signal for every measurement point.

NOTE: This may be achieved by using the following formula:

$$\text{sweep time} > \frac{2 \times (\text{PRI} \times \text{frequency span})}{\text{resolution bandwidth}}$$

where PRI = pulse repetition interval = 10 ms.

**Table 8**

Frequency offset from edge of band	Resolution Bandwidth	Peak Hold	Averaging
0 ... 2 MHz	30 kHz	on	none
2 ... 5 MHz	30 kHz	on	none
5 ... 10 MHz	100 kHz	on	none
10 ... 20 MHz	300 kHz	on	none
20 ... 30 MHz	1 MHz	on	none
30 ... 12 750 MHz	3 MHz	on	none

NOTE: The highest frequency of measurement should not exceed 12,75 GHz.

Measurements shall not be made for transmissions on the RF channel closest to the nearest band edge for frequency offsets of up to 2 MHz.

The centre frequencies of the DECT RF channels are defined in subclause 7.1;

- b) the LT shall place the EUT in a mode whereby the EUT is positioned in a LT specified slot and frequency. If so equipped, the handover function in the EUT shall be disabled. See subclause 5.9.3 for the appropriate test message reference;
- c) the EUT shall be placed in a test mode whereby it performs the loopback function as referenced in subclause 5.9.3;
- d) a test modulation signal D-M2 (see subclause 5.8.4.4) is generated by the LT;
- e) the LT shall initiate a power measurement procedure conforming to the limits specified in subclause 5.8.5 using the methods described in annex B (radiated spurious emissions);
- f) the test shall be carried out over the RF ranges from 30 MHz to 12,75 GHz and the power measurements shall be performed using the resolution bandwidth as indicated in table 8.

### 12.5.2.3 Verdict criteria}

The spurious emissions, as measured, shall not be greater than 250 nW at frequencies below 1 GHz and 1 µW at frequencies above 1 GHz.

In addition, not regarding up to 2 instances of a continuous-wave spurious signal for PPs for which the total peak power level shall be less than 250 nW as measured in a 3 MHz measurement bandwidth, the peak power level shall be less than 20 nW in a 100 kHz measuring bandwidth for the following broadcast bands:

47 - 74 MHz;  
 87,5 - 108 MHz;  
 108 - 118 MHz;  
 174 - 230 MHz;  
 470 - 862 MHz.

### 12.5.3 Conducted spurious emissions

#### 12.5.3.1 Test environment

The test shall take place under nominal supply voltage conditions and at a nominal temperature.

#### 12.5.3.2 Method of measurement

- a) The EUT shall be connected to the LT via the external antenna connector;
- b) carry out the test parts a) to f) in subclause 12.5.2.2 except in test part e), use the methods described in I-ETS 300 176 [13] annex C (conducted spurious emissions).

#### 12.5.3.3 Verdict criteria

The spurious emissions, as measured, shall not be greater than 250 nW at frequencies below 1 GHz and 1  $\mu$ W at frequencies above 1 GHz.

In addition, not regarding up to 2 instances of a continuous-wave spurious signal for PPs for which the total peak power level shall be less than 250 nW as measured in a 3 MHz measurement bandwidth, the peak power level shall be less than 20 nW in a 100 kHz measuring bandwidth for the following broadcast bands:

47 - 74 MHz;  
87,5 - 108 MHz;  
108 - 118 MHz;  
174 - 230 MHz;  
470 - 862 MHz.

## 13 Radio receiver testing

### 13.1 Radio receiver sensitivity

The requirements are given in subclause 6.2 of ETS 300 175-2 [2].

#### 13.1.1 Definition

The radio receiver sensitivity is defined as the power level at the receiver input at which the BER is 0,001. The radio receiver sensitivity shall be - 83 dBm or better.

#### 13.1.2 Test environment

The test should preferably take place at a test site, otherwise a test fixture or temporary connector shall be used.

If the EUT has an antenna connector then it shall be used to connect the EUT to the LT.

The test shall take place under nominal supply voltage conditions and at a nominal temperature.

#### 13.1.3 Method of measurement

- a) The EUT shall be oriented in the reference position as determined in subclause 5.11.3 if no antenna connector is available;
- b) the LT shall be programmed to set its RF transmission to a power level such that - 83 dBm shall be present at the input of the EUT receiver;
- c) the LT shall place the EUT in a mode whereby the EUT is positioned in a LT specified slot and RF channel  $c = 5$ . If so equipped, the handover function in the EUT shall be disabled. See subclause 5.9.3 for the appropriate test message reference;

- d) the EUT shall be placed in a test mode whereby it performs the loopback function as referenced in subclause 5.9.3;
- e) a test modulation signal D-M2 (see subclause 5.8.4.4) is generated by the LT;
- f) the LT shall calculate the BER of the EUT testing at least 1.6 million bits;
- g) the LT shall offset the frequency of the test signal by 50 kHz and repeat parts b) to f). This sequence of steps shall be repeated twice to include both positive and negative frequency offsets;
- h) parts b) to g) shall be repeated for RF channels  $c = 0$  and 9.

#### **13.1.4 Verdict criteria**

The BER of the EUT shall be less than or equal to 0,001 for the duration of this test.

#### **13.2 Radio receiver reference BER**

The requirements are given in subclause 6.3 of ETS 300 175-2 [2].

##### **13.2.1 Definition**

The radio receiver reference BER is the maximum allowed BER for a power level at the receiver input of - 73 dBm or greater (i.e. 70 dB $\mu$ V/m).

##### **13.2.2 Test environment**

The test shall take place at a test site or using a test fixture for equipment with integral antenna.

If the EUT has an antenna connector then it shall be used to connect the EUT to the LT.

The test shall take place under nominal supply voltage conditions and at a nominal temperature.

##### **13.2.3 Method of measurement**

- a) The EUT shall be oriented in the reference position as determined in subclause 5.11.3 if no antenna connector is available;
- b) the LT shall be programmed to set it's RF transmission to a power level of - 73 dBm at the input of the EUT receiver;
- c) the LT shall place the EUT in a mode whereby the EUT is positioned in a LT specified slot and RF channel  $c = 5$  with handover disabled. See subclause 5.9.3 for the appropriate test message reference;
- d) the EUT shall be placed in a test mode whereby it performs the loopback function as referenced in subclause 5.9.3;
- e) a test modulation signal D-M2 (see subclause 5.8.4.4) is generated by the LT;
- f) the LT shall calculate and record the BER of the EUT testing at least 160 million bits;
- g) parts b) to f) shall be repeated for RF channels  $c = 0$  and 9.

##### **13.2.4 Verdict criteria**

The BER of the EUT shall be 0,00001 or less.

**13.3 Radio receiver interference performance**

The requirements are given in subclause 6.4 of ETS 300 175-2 [2].

**13.3.1 Definition**

The ability of DECT equipment to continue receiving in the presence of an interfering signal on the same or different DECT RF channel.

**13.3.2 Test environment**

The test shall take place at a test site or using a test fixture for equipment with integral antenna.

If the EUT has an antenna connector then it shall be used to connect the EUT to the LT.

The test shall take place under nominal supply voltage conditions and at a nominal temperature.

**13.3.3 Method of measurement**

- a) The EUT shall be oriented in the reference position as determined in subclause 5.11.3 if no antenna connector is available;
- b) the LT shall be programmed to set its RF transmission to a power level of - 73 dBm at the input of the EUT receiver;
- c) the LT shall place the EUT in a mode whereby the EUT is positioned in a LT specified slot and RF channel  $c = 5$ . If so equipped, the handover function in the EUT shall be disabled (see subclause 5.9.3 for the appropriate test message reference);
- d) the EUT shall be placed in a test mode whereby it performs the loopback function as referenced in subclause 5.9.3;
- e) a test modulation signal D-M2 (see subclause 5.8.4.4) is generated by the LT;
- f) the LT shall transmit in addition to the D-M2 data test pattern, a modulated DECT-like carrier (see subclause 5.8.4.1) on channel "Y" whose level is determined by table 9.

**Table 9**

interferer on RF channel "Y":	interferer signal strength (dBµV/m)	signal strength (dBm)
Y = M	60	-83
Y = M ± 1	83	-60
Y = M ± 2	104	-39
Y = any other DECT channel	110	-33

The RF carriers "Y" shall include the three nominal DECT RF carrier positions immediately outside each edge of the DECT band.

- g) the LT calculates and records the BER of the EUT testing at least 1.6 million bits;
- h) parts b) to g) shall be repeated so that the single interfering DECT-like carrier has been placed on all the remaining DECT channels. Table 9 in part f) indicates the amplitude of the interferer;

- i) parts b) to h) shall be repeated for RF channels  $c = 0$  and  $9$ .

#### 13.3.4 Verdict criteria

The BER of the EUT shall be 0,001 or less.

#### 13.4 Radio receiver blocking case 1: owing to signals occurring at the same time but on other frequencies

The requirements are given in subclause 6.5.1 of ETS 300 175-2 [2].

##### 13.4.1 Definition

The receiver should work in the presence of strong signals on other frequencies. These interferers may be modulated carriers or single continuous-wave carriers.

##### 13.4.2 Test environment

The test shall take place at a test site or using a test fixture for equipment with integral antenna.

If the EUT has an antenna connector then it shall be used to connect the EUT to the LT.

The test shall take place under nominal supply voltage conditions and at a nominal temperature.

##### 13.4.3 Method of measurement

- a) The EUT shall be oriented in the reference position as determined in subclause 5.11.3 if no antenna connector is available;
- b) the power level of the RF transmission from the LT shall be set to 3 dB above the sensitivity limit;
- c) the LT shall place the EUT in a mode whereby the EUT is positioned in a LT specified slot and frequency ( $F_C$ ). The frequency chosen shall be RF channel  $c = 5$  of the DECT RF channels. If so equipped, the handover function in the EUT shall be disabled (see subclause 5.9.3 for the appropriate test message reference);
- d) the EUT shall be placed in a test mode whereby it performs the loopback function as referenced in subclause 5.9.3;
- e) a test modulation signal D-M2 (see subclause 5.8.4.4) is generated by the LT;
- f) the LT shall transmit in addition to the D-M2 signal a single continuous-wave interferer with an equivalent frequency change rate not exceeding the following:

<u>Equipment type</u>	<u>Frequency change rate</u>
A-field only	1 MHz/s;
half-slot	2,5 MHz/s;
full-slot	10 MHz/s;
double-slot	20 MHz/s.

The frequency ( $f$ ) and levels are determined by table 10 below. If discrete frequency steps are used, the step shall not exceed 1 MHz.

Table 10

Frequency (f)	Continuous-wave interferer level	
	for radiated measurements (dBµV/m)	for conducted measurements dBm
25 MHz ≤ f < 1 780 MHz	120	-23
1 780 MHz ≤ f < 1 875 MHz	110	-33
$ f - F_C  > 6$ MHz	100	-43
1 905 MHz < f ≤ 2 000 MHz	110	-33
2 000 MHz < f ≤ 12,75 GHz	120	-23

- g) The LT shall for frequencies and conditions defined under part f) monitor all bit errors with time intervals not exceeding 1 s;
- h) at frequencies where 1 or more errors are found the BER of the EUT shall be measured testing at least 1,6 million bits. If the BER, as measured, exceeds 0,001 the frequency shall be recorded;
- i) for all frequencies recorded under part h), the measurement and recording procedure shall be repeated, but with the interferer level decreased to 100 dBµV/m for radiated measurements or - 43 dBm for conducted measurements;
- j) for all frequencies recorded under part i), the measurement and recording procedure shall be repeated, but with the interferer level decreased to 80 dBµV/m for radiated measurements or to - 63 dBm for conducted measurements.

**13.4.4 Verdict criteria**

A spurious response frequency is defined as the nominal DECT carrier frequency  $F_g$  closest to a frequency recorded under part g).

NOTE:  $F_g$  is defined in ETS 300 175-2 [2], subclause 4.1.1 as the nominal DECT RF carrier whose centre frequency is generated by the formula:

$$F_g = F_0 - g \times 1\,728 \text{ kHz},$$

where  $F_0 = 1\,897,344$  MHz and  $g$  is any integer.

An occurrence is defined as a group of up to 3 spurious response frequencies with consecutive values of  $g$ . Two occurrences are defined as separate if between these occurrences there is at least one nominal DECT carrier frequency that is not a spurious response frequency.

Every recorded frequency is defined to be related to the closest spurious response frequency.

Every recorded frequency is defined to be related to the occurrence which contains the related spurious response frequency.

All frequencies recorded under part g) shall only relate to a maximum of 8 separated occurrences.

All frequencies recorded under part h) shall only relate to a maximum of 4 separated occurrences.

No frequency shall have been recorded under part i).

**13.5 Radio receiver blocking case 2: owing to signals occurring at a different time**

The requirements are given in subclause 6.5.2 of ETS 300 175-2 [2].

**13.5.1 Definition**

When a high level interferer is present in a physical channel other than the one the receiver is on, the receiver is able to continue receiving the desired signal.



### 13.5.2 Test environment

The test shall take place at a test site or using a test fixture for equipment with integral antenna.

If the EUT has an antenna connector then it shall be used to connect the EUT to the LT.

The test shall take place under nominal supply voltage conditions and at a nominal temperature.

### 13.5.3 Method of measurement

- a) The EUT shall be orientated in the reference position as determined in subclause 5.11.3 if no antenna connector is available;
- b) the LT shall be programmed to set its RF transmission to a power level of - 73 dBm at the input of the EUT receiver;
- c) the LT shall place the EUT in a mode whereby the EUT is positioned in RF channel  $c = 5$  and slotpair N(i.e. slot N and slot N+12 with N greater than or equal to 2). If so equipped, the handover function in the EUT shall be disabled. See subclause 5.9.3 for the appropriate test message reference;
- d) the EUT shall be placed in a test mode whereby it performs the loopback function as referenced in subclause 5.9.3;
- e) a test modulation signal D-M2 (see subclause 5.8.4.4) is generated by the LT;
- f) the LT shall transmit at the same time a DECT-like physical packet interferer at a level of -14 dBm in slot N-2 for measuring a PT and slot (N+12)-2 for measuring an FT. See subclause 5.8.4.1 for a description of this interferer;

The power level of any emissions by the LT shall be less than - 93 dBm on slot N-1 for measuring a PT and on slot (N+12)-1 for measuring an FT.

- g) the LT shall be programmed to set its RF transmission to a power level of - 83 dBm at the input of the EUT receiver in slot N for measuring a PT and in slot N+12 for measuring an FT;
- h) the testing system shall calculate and record the BER of the EUT testing at least 1,6 million bits;
- i) parts b) to h) shall be repeated with the EUTs receiver placed on RF channels  $c = 0$  and 9.

### 13.5.4 Verdict criteria

The BER of the EUT shall be 0,001 or less for the duration of this test.

## 13.6 Receiver intermodulation performance

The requirements are given in subclause 6.6 of ETS 300 175-2 [2].

### 13.6.1 Definition

With a call set up on a particular physical channel, two interferers are introduced so that they can produce an intermodulation product on the physical channel already in use.

### 13.6.2 Test environment

The test should preferably take place at a test site, otherwise a test fixture shall be used.

If the EUT has an antenna connector then it shall be used to connect the EUT to the LT.

The test shall take place under nominal supply voltage conditions and at a nominal temperature.

### 13.6.3 Method of measurement

- a) The EUT shall be oriented in the reference position as determined in subclause 5.11.3 if no antenna connector is available;
- b) the LT shall be programmed to set its RF transmission level to a power level of - 80 dBm at the input of the EUT receiver;
- c) the EUT's RF channel is recorded as channel "M";
- d) the LT shall place the EUT in a mode whereby the EUT is positioned in a LT specified slot and frequency. If so equipped, the handover function in the EUT shall be disabled. See subclause 5.9.3 for the appropriate test message reference;
- e) the EUT shall be placed in a test mode whereby it performs the loopback function as referenced in subclause 5.9.3;
- f) a test modulation signal D-M2 (see subclause 5.8.4.4) is generated by the LT;
- g) the LT shall then transmit in addition to the D-M2 test signal, a modulated DECT-like carrier "B" and a continuous-wave carrier "A" whose intermodulation product is present within the DECT channel "M" of the EUT. The level of these carriers shall be set to - 47 dBm at the receiver input of the EUT. The measurement shall be performed 4 times with the interfering carriers and the EUT receive channel positioned on the DECT RF channels as per the following table:

Table 11

M	A	B
5	7	9
5	3	1
0	2	4
9	7	5

- h) the LT shall calculate and record the BER of the EUT in the loopback field for each of the channel combinations shown in the table above, testing at least 1,6 million bits.

### 13.6.4 Verdict criteria

The BER shall be less than 0,001 for the duration of this test.

### 13.7 Spurious emissions when the PP has no allocated transmit channel

The requirements are given in subclause 6.7 of ETS 300 175-2 [2].

#### 13.7.1 Definition

The power level of any spurious emission when the PP has not been allocated a transmit channel.

#### 13.7.2 Test environment

The test shall take place at a test site.

Connection between the EUT and the LT shall be made by means of a test antenna.

The test shall take place under nominal supply voltage conditions and at a nominal temperature.

### 13.7.3 Method of measurement

a) The analyser controls shall be set to the following:

frequency span:	as required for frequency range;
resolution bandwidth:	1 MHz (in DECT band) 100 kHz (outside DECT band);
video bandwidth:	greater than resolution bandwidth;
averaging:	none;
peak hold:	on;
filtering type:	synchronously tuned for measurements in the DECT band;

b) the EUT shall be oriented in the reference position as determined in subclause 5.11.3;

c) the EUT shall be placed into a receive or idle mode for the duration of this test;

d) the test shall be carried out across the RF range of 30 MHz to 12,75 GHz and the power measurements shall be performed using the resolution bandwidths as indicated in part a) above.

### 13.7.4 Verdict criteria (outside the DECT band)

The EUT shall conform to the following limits:

- the emissions as measured shall not be greater than 2 nW between 30 MHz and 1 GHz; and
- between 1 GHz and 12,75 GHz, the emissions as measured shall not exceed 20 nW.

### 13.7.5 Verdict criteria (inside the DECT band)

The EUT shall conform to the following limits:

- the power level as measured of any spurious emissions shall not exceed 2 nW in a 1 MHz bandwidth.

The following exceptions are allowed:

- a) in one 1 MHz, the maximum allowable ERP shall be 20 nW;
- b) in up to two bands of 30 kHz, the maximum ERP shall be less than 250 nW.

## 14 Synchronisation port (FT only)

The requirements are given in annex C of ETS 300 175-2 [2].

### 14.1 Description

The (optional) synchronisation ports allow adjacent DECT FTs to achieve frame synchronisation.

Two classes of synchronisation are specified:

Class 1: Guard Band Alignment (GBA): no handover between FTs;

Class 2: Guard Band Alignment (GBA): handover between FTs.

The requirements of handover result in different timing tolerances between the two classes.

The synchronisation pulse is positive (true) logic. The voltage levels of this pulse corresponds to those defined in CCITT Recommendation V.11 [9].

## 14.2 Test environment

The test shall take place under nominal supply voltage conditions and at a nominal temperature.

The test should preferably take place at a test site, otherwise a test fixture shall be used.

The LT shall provide CCITT Recommendation V.11 [9] compatible testing ports for this test. The connecting cable between the LT and EUT ports shall be shielded.

Connection between the LT and the EUT for the RF sampling shall be by means of a test antenna or test fixture.

## 14.3 FT as the master

### 14.3.1 Method of measurement

The applicant shall declare to the testing laboratory the time required for system synchronization by the EUT.

- a) The EUT shall be orientated in the reference position as determined in subclause 5.11.3 if no antenna connector is available;
- b) the EUTs' synchronisation output port shall be connected to the LT's' input port;
- c) a bearer shall be set-up between the LT and the EUT. The position of the bearer shall be in slots 0 and 12 of the DECT frame;
- d) the LT shall:
  - 1) use the sampling method described in subclause 5.11.2.2 of this TBR to capture a representation of a physical packet transmitted by the EUT;
  - 2) determine the position of p0 in the physical packet;
  - 3) at the same time, sample the synchronisation pulse coming out of the EUT. The frame number in which the pulse is sampled shall be recorded;
- e) part d) shall be repeated for 50 frames;
- f) the LT shall calculate the widths of the synchronisation pulses. The calculated widths shall be recorded along with the frame numbers;
- g) the LT shall calculate the time delay,  $T_d$ , between the falling edge of each synchronisation pulse to bit p0 of that pulses' sampled RF packet.

### 14.3.2 Verdict criteria

The time delay,  $T_d$ , pulse widths, and voltages, as measured, shall meet the following limits:

- a) The width of the synchronising pulse shall be between 2 ms and 5 ms for frame 0 and between 5  $\mu$ s and 1 ms for all other frames;
- b)  $T_d = 15 \mu\text{s} \pm 5 \mu\text{s}$  for Class 1 FTs;
- c)  $T_d = 15 \mu\text{s} \pm 2 \mu\text{s}$  for Class 2 FTs;
- d) the voltage levels as defined in CCITT Recommendation V.11 [9].

## 14.4 FT as the slave

### 14.4.1 Method of measurement

The applicant shall declare to the testing laboratory the time required for system synchronization by the EUT.

- a) The EUT shall be orientated in the reference position as determined in subclause 5.11.3 if no antenna connector is available;
- b) the EUT's synchronisation input port shall be connected to the LT's output port;
- c) a bearer shall be set-up between the LT and the EUT. The position of the bearer shall be in slots 0 and 12 of the DECT frame;
- d) the LT shall:
  - 1) generate a synchronisation pulse in conformance with the limits specified for master FTs in annex C of ETS 300 175-2 [2];
  - 2) use the sampling method described in subclause 5.11.2.2 of this TBR to capture a representation of a physical packet transmitted by the EUT;
  - 3) determine the position of p0 in the physical packet;
- e) part d) shall be repeated for 50 frames;
- f) the LT shall calculate the time delay,  $T_d$ , between the falling edge of each synchronisation pulse it generated to bit p0 of that pulses' sampled RF packet from the EUT;
- g) if the EUT is designated as being Class 2, then the test laboratory shall verify that the time delay,  $T_d$ , can be set to 0  $\mu$ s, 15  $\mu$ s and 20  $\mu$ s. The method of adjustment is applicant-specific and shall be declared to the test laboratory.

### 14.4.2 Verdict criteria: Class 1 FTs

The time delay,  $T_d$ , shall be 15  $\mu$ s  $\pm$  5  $\mu$ s. The voltage levels as measured shall comply with those defined in CCITT Recommendation V.11 [9].

### 14.4.3 Verdict criteria: Class 2 FTs

The time delay,  $T_d$ , shall be 15  $\mu$ s  $\pm$  2  $\mu$ s and shall be able to be set to 0  $\mu$ s, 15  $\mu$ s and 20  $\mu$ s  $\pm$  2  $\mu$ s. The voltage levels as measured shall comply with those defined in CCITT Recommendation V.11 [9].

## 15 EMC

There are no EMC technical requirements which are specific to the equipment in the terms of the Terminal Directive 91/263/EEC, [11].

NOTE: Technical requirements for EMC performance and testing of the equipment are covered by the relevant standards applicable to the EMC Directive 89/336/EEC (see annex A).

## 16 Equipment identity testing

### 16.1 PP

This clause describes the protection requirements of the mandatory IPEI (International Portable Equipment Identity) equipment code. For information on the procurement and coding of the IPEI, refer to ETS 300 175-6 [6].

The applicant shall declare that it is not possible for the user to alter the IPEI using any normally accessible procedure.

The applicant shall supply, in addition to the equipment, sufficient means in the equipment with instructions in the documentation to permit validation of the Equipment Manufacturer's Code (EMC) and verification of the existence of the Portable equipment Serial Number (PSN) code in the equipment.

### 16.2 FP

The applicant shall declare that:

- DECT FPs which do not transmit the TA escape message transmits the N<sub>T</sub> message as defined in ETS 300 175-3 [3] at least once every 10 seconds on all active physical channels;
- these N<sub>T</sub> identity messages are transmitted with the appropriate A-field header code as defined in ETS 300 175-3 [3] and the N<sub>T</sub> message contains an ETSI distributed code as defined in ETS 300 175-6 [6].

## 17 Efficient use of the radio spectrum

### 17.1 Channel selection

The applicant shall declare that he conforms to all obligatory conditions in subclauses 11.4 and 11.6 of ETS 300 175-3 [3].

### 17.2 Channel confirmation

#### 17.2.1 For the PT

The applicant shall declare that for the PT:

- the first PT transmission on the newly selected channel shall be made in accordance with the scan sequence of the addressed RFP;
- to continue transmitting on the newly selected physical channel the PT shall receive an indication that the FT is receiving the PT transmissions within 2 frames of the first PT transmission.

#### 17.2.2 For the FT

The applicant shall declare that for the FT:

- the RFP shall not transmit on more than 2 physical channels for which complementary physical channels do not exist;
- a complementary physical channel is a physical channel between the same two REPs which occurs 5 ms before or after the physical channel to which it is complementary;
- when an FT is addressing a specific PT then the first FT transmission shall be made in accordance with the scan sequence of the addressed PT receiver;

- to continue transmitting on the selected physical channel the FT shall receive an indication that the PT is receiving the FT transmissions within 2 frames of the first FT transmission.

### 17.3 Channel release

The applicant shall declare that:

- a REP shall cease transmission on all physical channels if it has not received a valid indication of the other REP's identity within 10 seconds of the receipt of the last indication;
- a REP which transmits on both the physical channel and complementary physical channel shall cease to transmit on the channels if:

Either:

- a) the receiving endpoint indicates to the transmitting endpoint that transmission shall cease on both these physical channels; or
- b) the transmitting FT or PT is no longer attempting to receive at least one physical channel from the FT or PT to which it is transmitting.

### 17.4 General

For an FT or PT the applicant shall declare that:

- no more than two physical channels based on the half slot format shall be sent within the same frame to the same REP;
- the EUT is capable of communicating on all 10 DECT RF channels.

## 18 Supplement to test procedures in ETS 300 175-3

This clause makes reference to subclauses in ETS 300 175-3 [3] MAC layer, and they should be read in conjunction with this ETS.

### 18.1 A field loopback

The additions to ETS 300 175-3 [3] subclause 7.2.5.4.3 are as follows in subclauses 18.1 to 18.3.

#### 18.1.1 PP under test

The LT(FP) shall send  $M_T$  tails containing the loopback message and loopback data as described in ETS 300 175-3 [3] subclause 7.2.5.4.3 in all odd numbered frames in accordance with the T-mux algorithm. The LT(FP) shall continue to send  $N_T$  channel information on even numbered frames and  $Q_T$  channel information on frame 8 according to the T-mux.

#### 18.1.2 FP under test

The LT(PP) shall send  $M_T$  tails containing the loopback test message and loopback data as described in ETS 300 175-3 [3] subclause 7.2.5.4.3 in all even numbered frames. The LT(PP) shall continue to send  $N_T$  channel information on odd frames according to the T-mux algorithm.

#### 18.1.3 General rule

Test messages for loopback are sent on all  $M_T$  frames allowed by the T-mux algorithm. The whole  $M_T$  message is looped back by the EUT in the next frame.

### **18.2 Connectionless service only equipment with transmitters**

Insert into ETS 300 175-3 [3] subclause 12.1:

"DECT equipment that implements only connectionless services shall not be required to implement the test messages. However, the applicant shall declare to the test laboratory how the functions of force transmit, loopback, defeat antenna diversity and clear test modes shall be initiated."

### **18.3 Speed of test message execution**

Replace sentences in ETS 300 175-3 [3] subclauses 12.2.1 and 12.2.2, "Test messages shall be transmitted.....same multiframe" with:

"The EUT shall execute the test message within 16 frames of the reception of the test message."

### **18.4 Allow initial dummy bearer**

Insert in ETS 300 175-3 [3] subclause 12.2 in first sentence after figure 104.

"...the IUT shall have no active bearers other than those initiated by the LT with the exception of dummy bearers."

### **18.5 Editorial**

Delete first sentence in ETS 300 175-3 [3] subclause 12.2.1: "Entry...".



## **Annex A (informative): Bibliography**

- Construction of a Stripline: Technical Report FTZ N° 512 TB 9.
- Construction of an Anechoic Chamber: Technical Report ZVEI AK-R 90/20.
- IEC Publication 489-3 Second edition (1988) Appendix F pages 130 to 133.
- 89/336/EEC: "Council Directive of 3rd May 1989 on the approximation of the laws of the Member States relating to Electromagnetic Compatibility".

## Annex B (normative): Procedures for test fixture calibration and for measurement of radiated spurious emissions

### B.1 Calibration of test fixture for receiver measurements

The calibration procedure utilises the average measured usable sensitivity of the receiver. The average measured usable sensitivity expressed as field strength for bit stream shall be the average of eight measurements of field strength, expressed in dB $\mu$ V/m, at the nominal frequency of the receiver and with specified test modulation which produces after demodulation a data signal with a BER of  $10^{-3}$ , when the receiver is rotated in  $45^\circ$  increments, starting at the reference orientation.

#### B.1.1 Method of measurement

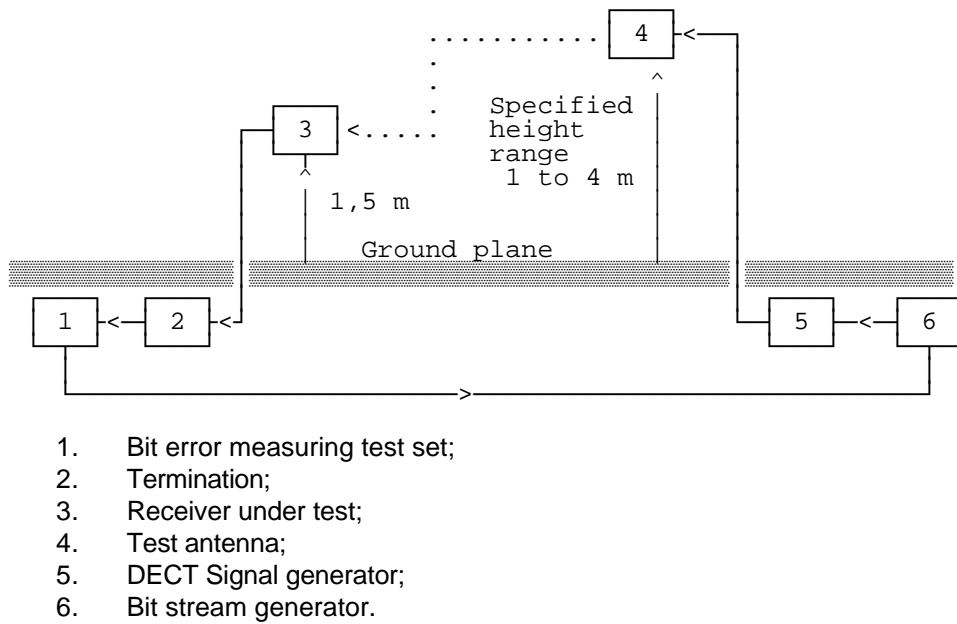

Figure B.1: Measurement arrangement N°1

- a) A test site which fulfils the requirements of the specified frequency range of this measurement shall be used. The test antenna shall be oriented initially for vertical polarisation unless otherwise stated.

A signal generator capable of producing a DECT signal shall be connected to the test antenna. The signal generator shall be at the nominal frequency of the receiver and shall be modulated by the test modulation D-M2. The receiver under test shall be placed on the support in its standard position and oriented so that a face, specified by the applicant, is normal to the direction of the test antenna. This is the reference orientation for the measurement;

- b) the bit pattern of the modulating signal shall be compared to the bit pattern obtained from the receiver after demodulation;
- c) the output level of the signal generator shall be adjusted until a BER of  $10^{-3}$  is obtained;
- d) the test antenna shall be raised or lowered again through the specified height range to find the lowest level of the test signal which produces the same BER;
- e) record the minimum signal generator level from steps c) or d);

- f) steps b) to e) above shall be repeated for the eight positions 45° apart of the receiver and the corresponding values of the generator output which produces the same BER will be determined and recorded;
- g) using the calibration of the test site, calculate the eight field strengths  $X_i(\mu\text{V/m})$  corresponding to the output level above of the signal generator. The average measured usable sensitivity expressed as field strength  $X_{\text{mean}}$  (dB $\mu\text{V/m}$ ) is given by:

$$X_{\text{mean}} = 20 \log \left[ \frac{8}{\sum_{i=1}^{i=8} (1/X_i^2)} \right]^{1/2}$$

- h) measurements b) to g) above shall be repeated with the test antenna oriented in horizontal polarisation;
- i) record the lower value of the two recorded in steps g) and h) above;
- j) using the test fixture in measuring arrangement N°2 the measurement may also be performed under extreme test conditions.

Additional uncertainties can occur under extreme test conditions due to the calibration of the test fixture;

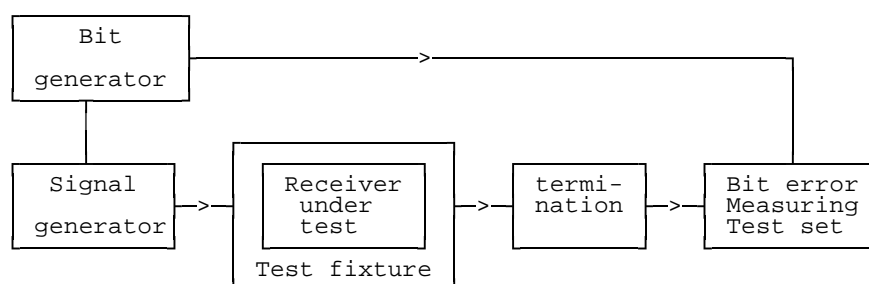

**Figure B.2: Measurement arrangement N°2**

- k) the test signal input level providing a BER of  $10^{-3}$  shall be determined under normal and extreme test conditions and the difference in dB is noted. This difference shall be algebraically added to the average measured usable sensitivity to radiated fields for bit stream expressed in dB $\mu\text{V/m}$  under normal test conditions, to obtain the same quantity under extreme test conditions.

## B.2 Radiated measurements

### B.2.1 General

This clause contains all methods of measurements involving the absolute measurement of a radiated field. This field may be radiated by an integral antenna and/or by the cabinet of the equipment itself.

The standard test site shall be a calibrated open air test site, whose dimensions are appropriate to the frequency range of measurements.

In some cases operating on a test site may produce electromagnetic perturbation or, conversely, external radiations may disturb the measurement. For these reasons, and also in order to reduce the space required, other arrangements may be used, such as:

- stripline arrangements;
- anechoic chamber;
- indoor test site.

The methods of measurement described in this annex are based on an open air test site, unless otherwise stated. If a stripline arrangement, an anechoic chamber or an indoor test site are used, the changes which apply to the method of measurement are indicated in their corresponding descriptions. For each radiated measurement, the nature and the dimensions of the test arrangement used shall be recorded in the test report.

For extreme test conditions a test fixture shall also be required.

For equipment normally operated from internal batteries it may be necessary to operate it from an external power source. A RF filter may be required to avoid radiation to or from the power leads.

### B.2.2 Radiated spurious emissions

#### B.2.2.1 Definition

Spurious emissions are emissions at frequencies, other than those of the carrier and sidebands associated with normal modulation, radiated by the antenna and by the cabinet of the transmitter.

They are specified as the radiated power of any discrete signal.

#### B.2.2.2 Method of measurement

This method of measurement applies to transmitters having an integral antenna.

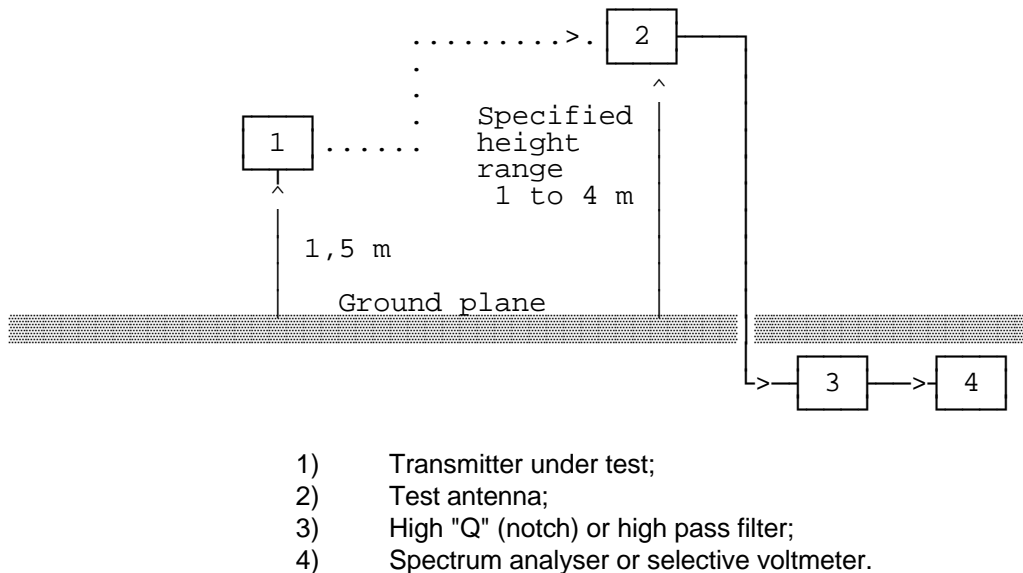

Figure B.3: Measurement arrangement N°1

- a) A test site which fulfils the requirements of the specified frequency range of this measurement shall be used. The test antenna shall be oriented initially for vertical polarisation and connected to a spectrum analyser or a selective voltmeter, through a suitable filter to avoid overloading of the spectrum analyser or selective voltmeter. The bandwidth of the spectrum analyser is set to a suitable value to correctly perform the measurement.
- For the measurement of spurious emissions below the second harmonic of the carrier frequency the filter used shall be a high "Q" (notch) filter centred on the transmitter carrier frequency and attenuating this signal by at least 30 dB.

For the measurement of spurious emissions at and above the second harmonic of the carrier frequency the filter used shall be a high pass filter with a stop band rejection exceeding 40 dB. The cut-off frequency of the high pass filter shall be approximately 1,5 times the transmitter carrier frequency.

The transmitter under test shall be placed on the support in its standard position and shall be switched on;

- b) the radiation of any spurious emission shall be detected by the test antenna and spectrum analyser or selective voltmeter over the specified frequency range, except for the channel on which the transmitter is intended to operate and its adjacent channels. The frequency of each spurious emission detected shall be recorded. If the test site is disturbed by interference coming from outside, this qualitative search may be performed in a screened room, with a reduced distance between the transmitter and the test antenna;
- c) for each frequency at which a emission has been detected, the spectrum analyser or selective voltmeter shall be tuned and the test antenna shall be raised or lowered through the specified height range until a maximum signal level is detected on the spectrum analyser or selective voltmeter;
- d) the transmitter shall be rotated through 360° about a vertical axis, until the maximum signal is received;
- e) the test antenna shall be raised or lowered again through the specified height range until the maximum is obtained. This level shall be recorded;

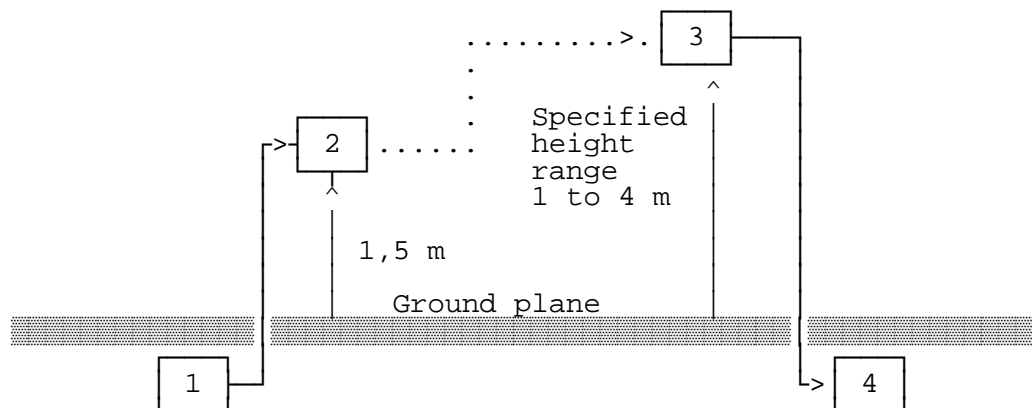

- 1) Signal generator;
- 2) Substitution antenna;
- 3) Test antenna;
- 4) Spectrum analyser or selective voltmeter.

**Figure B.4: Measurement arrangement N°2**

- f) using measurement arrangement N°2 the substitution antenna shall replace the transmitter antenna in the same position and in vertical polarisation. It shall be connected to the signal generator;

- g) for each frequency at which an emission has been detected, the signal generator, substitution antenna, and spectrum analyser or selective voltmeter shall be tuned. The test antenna shall be raised or lowered through the specified height range until the maximum signal level is detected on the spectrum analyser or selective voltmeter. The level of the signal generator shall be adjusted giving the same signal level on the spectrum analyser or selective voltmeter as in item e) above and this level shall be recorded.

This value, after corrections due to the gain of the substitution antenna and the cable loss between the signal generator and the substitution antenna, is the radiated spurious emission level of this frequency;

- h) steps c) to g) above shall be repeated with the test antenna oriented in horizontal polarisation;
- i) steps c) to h) above shall be repeated with the transmitter in stand-by condition if this option is available.

**B.2.3 Cabinet radiation**

**B.2.3.1 Definition**

Cabinet radiation is radiation at frequencies, excluding the band containing the carrier and sidebands associated with normal modulation, coming from the cabinet of the transmitter.

It is specified as the radiated power of any discrete signal.

**B.2.3.2 Method of measurement**

This method of measurement applies to transmitters having an antenna socket.

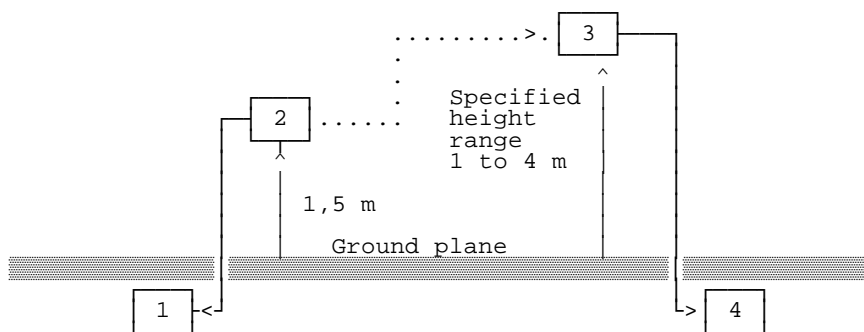

- 1) Test load;
- 2) Transmitter under test;
- 3) Test antenna;
- 4) Spectrum analyser or selective voltmeter.

**Figure B.4: Measurement arrangement N°1**

- a) A test site which fulfils the requirements of the specified frequency range of this measurement shall be used. The test antenna shall be oriented initially for vertical polarisation and connected to a spectrum analyser or selective voltmeter. The bandwidth of the spectrum analyser or selective voltmeter shall be between 10 and 100 KHz, set to a suitable value to correctly perform the measurement.

The transmitter under test shall be placed on the support in its standard position, connected to a test load and switched on without modulation;

- b) the same method of measurement as steps b) and i) of subclause 5.2.2 shall be used.

## Annex C (informative): Essential requirement justification

The table below provides a summary of the essential requirement articles of the Terminal Directive [11] justifying the tests in this TBR.

**Table 12**

Test Case	Test case	clause \ subclause Number	Article
1	Accuracy and stability of RF carriers	7	4e
2	Timing jitter: slot-slot on the same channel	8.3	4e
3	no longer required		4e
4	Reference timing accuracy of a RFP	8.4	4e
5	Transmission Burst	9	4e
6	Transmitted power: PP and RFP with an integral antenna	10.2	4e
7	Transmitted power: PP and RFP with an external antenna connector	10.3	4e
8	RF carrier modulation	11	4e
9	Emissions due to modulation	12.2	4e
10	Emissions due to transmitter transients	12.3	4e
11	Emissions due to intermodulation	12.4	4e
12	Spurious emissions when allocated a transmit channel	12.5	4e
13	no longer required		
14	Radio receiver sensitivity	13.1	4e
15	Radio receiver reference bit error ratio	13.2	4e
16	Radio receiver interference performance	13.3	4e
17	Radio receiver blocking case 1	13.4	4e
18	Radio receiver blocking case 2	13.5	4e
19	Receiver intermodulation performance	13.6	4e
20	Spurious emissions when the radio endpoint has no allocated transmit channel	13.7	4e
21	Synchronisation port	14	4e
22	EMC	15	
23	Equipment identity verification/safeguards	16	4e
24	Efficient use of radio spectrum	17	4e

## Annex D (normative): Test Support Profile (TSP)

### D.1 Introduction

This annex defines the provisions of the TSP for DECT equipment under test (EUT) capabilities in Test Standby Mode (TSM), and for the Lower Tester (LT) capabilities while performing TBR 6 tests. When there exists a reference to "TSM" in this TBR, it shall be applied for both; the test standby mode and the test mode(s) in operation as described in ETS 300 175-3 [3], subclause 12.2.

It specifies three different bearer setup procedures, as described in subclauses 10.5.1.1, 10.5.1.2, 10.5.1.3 of ETS 300 175-3 [3] in order to transfer test messages described in clause 12 and subclause 7.2.5.4 of ETS 300 175-3 [3]. One of these 3 bearer setup procedures shall be supported by the LT and EUT.

### D.2 Standardised symbols for the status column

The standardised symbols for the status column are as follows:

- M for always mandatory (the capability is required to be implemented). M1, M2, M3 for mandatory in respective order for basic bearer setup, A-field advanced single bearer setup and B-field single bearer setup procedures supported (if bearer setup type n is not supported then Mn shall be understood to mean O);
- O for optional (Boolean) (the capability may be implemented, but can be ignored on receipt);
- X for prohibited or excluded (the capability is not allowed to be implemented);
- I for out of scope in the test standby mode (the capability is allowed to be implemented, but is irrelevant in the test standby mode);
- - (dash) for not applicable (the capability is not possible to implement);
- C for conditional (the capability depends on the selection of other optional and/or conditional items). C1, C2, C3 for conditional in respective order for basic bearer setup, A-field advanced single bearer setup and B-field single bearer setup procedures supported (if bearer setup type n is not supported then Cn shall be understood to mean O).

All other capabilities not shown in this annex shall be regarded as optional or out of scope. Table D.1 and D.2 show the interpretation of these symbols in this annex.

**Table D.1: Usage of symbols**

Symbols\ Usage	Allowed to be implemented in the EUT	Possible in normal operation (ETS 300 175)	Possible in TSM (this TBR)	Out of scope of TSM
M	Yes	Yes	Yes	No
O	Yes	Yes	Yes	No
I	Yes	Yes	No	Yes
-	No	No	No	Yes
X	Yes	Yes	No	Yes



Table D.2: Symbols and their relation to transmit and receive events

Symbols\ TX, RX	Transmit	Receive
M	shall process and send	if received; shall process
O	allowed to be sent	if received; optionally processed
I	not possible to send (in TSM)	not possible to receive (in TSM)
-	not possible ever	not possible ever
X	not allowed to be sent in TSM	if received: not allowed to be processed in TSM

### D.3 Capabilities of PP under test

#### D.3.1 Services

Table D.3: Broadcast services

Broadcast services supported				
Item No	Name of service	Ref.	PT Status	LT Status
1	Continuous broadcast	5.7.1.1	M	M
2	System identities	11.3.2	O	M
3	System information	11.3.2	M	M

#### D.3.2 Messages

Table D.4: Header-field messages

Header-field messages						
Item No	Message	Ref.	Sending		Receipt	
			PT Status	LT Status	PT Status	LT Status
4	Identities information	7.1.2	M	M	O	O
5	Multiframe synchronisation and system information	7.1.2	-	M	M	-
6	Escape	7.1.2	O	X	I	X
7	MAC layer control	7.1.2	M	M	M	M
9	First PP transmission	7.1.2	M	-	-	O
12	U-type, IN, SIN or IP packet number 0,1	7.1.4	M	M	M	M
16	E-type, not all CF or CLF; packet number 0	7.1.4	C3a	X	I	M3
17	E-type, not all CF; CF packet number 1	7.1.4	C3a	X	I	M3
18	E-type, all MAC control (unnumbered)	7.1.4	C3a	M3	M3	M3
19	No B-field	7.1.4	O	O	O	O

C3a: At least one of the set is mandatory for the EUT.

C3b: At least one of the set is mandatory for the LT.

Table D.5: Messages in the A-tail field

Messages in the A-tail field						
Item No	Message	Ref.	Sending		Receipt	
			PT Status	LT Status	PT Status	LT Status
1	Identities information	7.2.2	O	M	O	O
2	Static system information	7.2.3.2	-	M	M	-
3	Extended RF carrier information	7.2.3.3	-	X	I	-
4	Fixed part capabilities	7.2.3.4	-	M	O	-
8	Q-channel escape	7.2.3.8	-	X	I	-
31	Basic CC access request	7.2.5.2.2	M1	-	-	M1
32	Basic CC bearer handover request	7.2.5.2.2	O	-	-	M1
33	Basic CC connection handover request	7.2.5.2.2	O	-	-	M1
35	Basic CC bearer confirm	7.2.5.2.2	-	M1	O	-
36	Basic CC bearer release	7.2.5.2.2	O	X	I	M1
37	Basic CC wait	7.2.5.2.3	-	X	I	-
38	Advanced CC access request	7.2.5.3.2	M2	X	I	M2
39	Advanced CC bearer handover request	7.2.5.3.3	O	X	I	M2
40	Advanced CC connection handover request	7.2.5.3.4	O	X	I	M2
41	Advanced CC unconfirmed access request	7.2.5.3.5	O	X	I	O
42	Advanced CC bearer confirm	7.2.5.3.6	O	M2	M2	O
43	Advanced CC wait	7.2.5.3.7	O	M2	O	M2
44	Advanced CC attributes_T, request	7.2.5.3.8	M2	X	I	M2
45	Advanced CC attributes_T, confirm	7.2.5.3.8	O	M2	O	O
46	Advanced CC bandwidth_T, request	7.2.5.3.9	O	X	I	O
47	Advanced CC bandwidth_T, confirm	7.2.5.3.9	O	O	O	O
51	Advanced CC release	7.2.5.3.13	O	X	I	M2

(continued)

Table D.5 (concluded): Messages in the A-tail field

Messages in the A-tail field						
Item No	Message	Ref.	Sending		Receipt	
			PT Status	LT Status	PT Status	LT Status
52	MAC test force transmit	7.2.5.4.2	-	M	M	-
53	MAC test loopback data	7.2.5.4.3	-	M	M	-
54	MAC test defeat antenna diversity	7.2.5.4.4	-	M	M	-
55	MAC test force bearer handover	7.2.5.4.5	-	I	I	-
56	MAC test escape	7.2.5.4.6	X	X	I	I
58	MAC test clear test modes	7.2.5.4.8	-	M	M	-
82	B-field setup, first PT transmission	7.2.5.8	O	-	-	M3
83	MAC control escape	7.2.5.9	O	X	I	O

Table D.6: Messages in the B-tail field

Messages in the B-tail field						
Item No	Message	Ref.	Sending		Receipt	
			PT Status	LT Status	PT Status	LT Status
1	Advanced CC access request	7.3.3.2	M3	X	I	M3
2	Advanced CC bearer handover request	7.3.3.2	O	X	I	M3
3	Advanced CC connection handover request	7.3.3.2	O	X	I	M3
4	Advanced CC unconfirmed access request	7.3.3.2	O	X	I	O
5	Advanced CC bearer confirm	7.3.3.3	O	M3	M3	O
6	Advanced CC wait	7.3.3.4	O	X	O	O
9	B-field bandwidth-B request	7.3.3.6	O	X	O	O
14	Advanced CC release	7.3.3.10	O	X	O	M3
30	B-field escape	7.3.8	O	X	I	X

**D.3.3 Message parameters**

The slot type shall be set correctly in all message parameters.

The equipment supplier shall provide message parameter details for configuring the LT.

**Table D.7: Parameters for A-field static system information message**

Parameters for A-field static system information message						
Item No	Name of Parameter	Ref.	PT Status	LT Status	Values	
					PT Allowed	LT Allowed
1	Normal-reverse	7.2.3.2.2	M	M	0,1	0
2	Slot number	7.2.3.2.3	M	M	0-11	0-11
3	Start position	7.2.3.2.4	M	M	0,2	0,2
4	QT escape bit	7.2.3.2.5	M	M	0,1	0,1
5	Number of transceivers	7.2.3.2.6	O	M	0-3	0
6	Extended RF carrier information available	7.2.3.2.7	O	M	0,1	0
7	RF carriers available	7.2.3.2.8	O	M	1-1023	1-1023
8	Carrier number	7.2.3.2.10	O	M	0-9	0-9
9	Primary receiver scan carrier number	7.2.3.2.12	O	M	0-9	0-9

Table D.8: Parameters for MAC fixed part capability message

Parameters for A-field MAC fixed part capability message						
Item No	Name of parameter	Ref.	PT Status	LT Status	Values	
					PT Allowed	LT Allowed
1	Extended fixed part information	7.2.3.4.2	O	M	0,1	0
2	Double slot	7.2.3.4.2	O	M	0,1	0,1
3	Half slot	7.2.3.4.2	O	M	0,1	0,1
4	Full slot	7.2.3.4.2	O	M	0,1	0,1
5	Frequency control	7.2.3.4.2	O	M	0,1	0
6	Page repetition	7.2.3.4.2	O	M	0,1	0
7	C/O setup on dummy bearer allowed	7.2.3.4.2	O	M	0,1	0
8	C/L uplink	7.2.3.4.2	O	M	0,1	0
9	C/L downlink	7.2.3.4.2	O	M	0,1	0
10	Basic A-field setup	7.2.3.4.2	O	M	0,1	0,1
11	Advanced A-field setup	7.2.3.4.2	O	M	0,1	0,1
12	B-field setup	7.2.3.4.2	O	M	0,1	0,1
13	CF messages	7.2.3.4.2	O	M	0,1	0
14	IN minimum delay	7.2.3.4.2	O	M	0,1	0,1
15	IN normal delay	7.2.3.4.2	O	M	0,1	0,1
16	IP error detection	7.2.3.4.2	O	M	0,1	0,1
17	IP error correction	7.2.3.4.2	O	M	0,1	0,1
18	Multibearer connections	7.2.3.4.2	O	M	0,1	0,1

**Table D.9: Parameters for higher layer information fixed part capability message**  
(ref. ETS 300 175-5 [5], annex F)

Parameters for A-field higher layer information fixed part capability message						
Item No	Name of parameter	Ref.	PT Status	LT Status	Values	
					PT Allowed	LT Allowed
1	ADPCM/G.721 Voice service	a32	O	M	0,1	0,1
2	Public Access Profile (PAP) supported	a33	O	M	0,1	0,1
3	Non-voice circuit switched service	a34	O	M	0,1	0,1
4	Non-voice packet switched service	a35	O	M	0,1	0,1
5	Standard authentication required	a36	O	M	0,1	0,1
6	Standard ciphering supported	a37	I	M	0,1	0
7	Location registration supported	a38	O	M	0,1	0,1
8	SIM services available	a39	O	M	0,1	0,1
9	Non-static Fixed Part (FP)	a40	O	M	0,1	0,1
10	CISS services available	a41	O	M	0,1	0,1
11	CLMS services available	a42	O	M	0,1	0,1
12	COMS services available	a43	O	M	0,1	0,1
13	Access rights requests supported	a44	O	M	0,1	0,1
14	External handover supported	a45	O	M	0,1	0,1
15	Connection handover supported	a46	O	M	0,1	0,1
16	Reserved	a47	O	M	0,1	0,1

D.3.4 Procedure support

Table D.10: Procedures supported

Procedure supported				
Item No	Name of Procedure	Ref.	PT Status	LT Status
1	Downlink continuous broadcast	9.1.1	M	M
21a	Basic bearer setup	10.5.1.1	M1	M1
22	A-field advanced single bearer setup	10.5.1.3	M2	M2
23	B-field single bearer setup	10.5.1.3	M3	M3
27	Duplex bearer handover procedure	10.6.2	O	M
29	Unacknowledge bearer release	10.7.2.1	O	M
36	Idle lock state entering procedure	10.6.2	O	X
37	Idle lock state maintaining procedure	10.6.2	O	X
40	Duplex bearer physical channel selection	11.4.1	X	-
41	Double simplex bearer physical channel selection	11.4.1	X	-
45a	RFP idle receiver scan sequence	11.8	O	M
45b	PP fast setup receiver scan sequence	11.9	O	X
46	Test message	12.2	M	M

## D.3.5 CSF multiplexing functions

Table D.11: CSF multiplexing functions

CSF multiplexing functions				
Item No	Name of function	Ref.	PT Status	LT Status
1	D-field MAP D80	6.2.1.1	Ca	Cb
2	D-field MAP D32	6.2.1.1	Ca	Cb
3	D-field MAP D08	6.2.1.1	Ca	Cb
4	D-field MAP D00	6.2.1.1	Ca	Cb
5	A-field MAP	6.2.1.2	M	M
6	B-field MAP D80 unprotected	6.2.1.3	Cc	Cd
7	B-field MAP D32 unprotected	6.2.1.3	Cc	Cd
8	B-field MAP D08 unprotected	6.2.1.3	Cc	Cd
9	B-field MAP D80 protected	6.2.1.3	Cc	Cd
10	B-field MAP D32 protected	6.2.1.3	Cc	Cd
11	B-field MAP D08 protected	6.2.1.3	Cc	Cd
12	Tail multiplexer	6.2.2.1	M	M
13	E/U-mux E80	6.2.2.2	Ce	Cf
14	E/U-mux E32	6.2.2.2	Ce	Cf
15	E/U-mux E08	6.2.2.2	Ce	Cf
16	E/U-mux U80a	6.2.2.2	Ce	Cf
17	E/U-mux U32a	6.2.2.2	Ce	Cf
18	E/U-mux U08a	6.2.2.2	Ce	Cf
19	E/U-mux U80b	6.2.2.2	Ce	Cf
20	E/U-mux U32b	6.2.2.2	Ce	Cf
21	E/U-mux U08b	6.2.2.2	Ce	Cf
32	C-mux Double Slot mode 10	6.2.2.3.1	C3g	C3g
37	C-mux Full Slot mode 4	6.2.2.3.1	C3h	C3h
39	C-mux Half Slot mode 1	6.2.2.3.2	C3i	C3i

(continued)



Table D.11 (concluded): CSF multiplexing functions

CSF multiplexing functions				
Item No	Name of function	Ref.	PT Status	LT Status
40	Encryption	6.2.3	O	O
41	Scrambling	6.2.4	M3	M3
42a	A-field R-CRC generation	6.2.5.2	M	M
42b	B-field R-CRC generation	6.2.5.2	M3	M3
43a	A field R-CRC checking	6.2.5.2	M	M
43a	B-field R-CRC checking	6.2.5.2	M3	M3
44	X-CRC generation	6.2.5.4	M	M
45	X-CRC checking	6.2.5.4	M	O
46	Broadcast control function	6.2.6	-	M
<p>For A-field setups (i.e. type 1 and 2): only A-field R-CRC is mandatory.</p> <p>Ca: At least one shall be supported by the EUT.</p> <p>Cb: At least one shall be supported by the LT.</p> <p>Cc: At least one shall be supported by the EUT.</p> <p>Cd: At least one shall be supported by the LT.</p> <p>Ce: At least one shall be supported by the EUT.</p> <p>Cf: At least one shall be supported by the LT.</p> <p>C3g: Mandatory if double slot supported.</p> <p>C3h: Mandatory if full slot supported.</p> <p>C3i: Mandatory if half slot supported.</p>				

### D.3.6 Timer and counter support

Those timers and counters required by the mandatory procedures are classified as mandatory (see table D.10).

## D.4 Capabilities of FP under test

### D.4.1 Services

Table D.12: Broadcast services

Broadcast services supported				
Item No	Name of service	Ref.	FT Status	LT Status
1	Continuous broadcast	5.7.1.1	M	M
2	System identities	5.7.1.1	O	M
3	System information	5.7.1.1	M	M

### D.4.2 Messages

Table D.13: Header field messages

Header-field messages						
Item No	Message	Ref.	Sending		Receipt	
			FT Status	LT Status	FT Status	LT Status
3	Identities information on C/L bearer	7.1.2	O	-	-	M
4	Identities information	7.1.2	M	M	M	M
5	Multiframe synchronisation and system information	7.1.2	M	-	-	M
6	Escape	7.1.2	X	X	I	-
7	MAC layer control	7.1.2	M	M	M	M
9	First PP transmission	7.1.2	-	M	M	-
12	U-type, IN, SIN or IP packet number 0	7.1.4	M	M	M	M
16	E-type, not all CF or CLF ; packet number 0	7.1.4	C3a	C3b	C3a	C3b
17	E-type, not all CF ; CF packet number 1	7.1.4	C3a	C3b	C3a	C3b
18	E-type, all MAC control (unnumbered)	7.1.4	C3a	C3b	C3a	C3b
19	No B-field	7.1.4	O	O	O	M
C3a:	At least one of the set is mandatory for the EUT.					
C3b:	At least one of the set is mandatory for the LT.					

Table D.14: Messages in the A-tail field

Messages in the A-tail field						
Item No	Message	Ref.	Sending		Receipt	
			FT Status	LT Status	FT Status	LT Status
1	Identities information	7.2.2	O	M	O	M
2	Static system information	7.2.3.2	M	-	-	M
3	Extended RF carrier information	7.2.3.3	X	-	-	I
4	Fixed part capabilities	7.2.3.4	O	-	-	M
8	Q-channel escape	7.2.3.8	O	-	-	X
31	Basic CC access request	7.2.5.2.2	-	M1	M1	-
32	Basic CC bearer handover request	7.2.5.2.2	-	X	I	-
33	Basic CC connection handover request	7.2.5.2.2	-	X	I	-
34	Basic CC unconfirmed access request	7.2.5.2.2	-	X	I	-
35	Basic CC bearer confirm	7.2.5.2.2	M1	-	-	M1
36	Basic CC bearer release	7.2.5.2.2	O	M1	M1	M1
37	Basic CC wait	7.2.5.2.3	O	M1	O	M1
38	Advanced CC access request	7.2.5.3.2	O	M2	M2	O
39	Advanced CC bearer handover request	7.2.5.3.3	-	X	I	-
40	Advanced CC connection handover request	7.2.5.3.4	O	X	I	O
41	Advanced CC unconfirmed access request	7.2.5.3.5	O	X	I	O
42	Advanced CC bearer confirm	7.2.5.3.6	M2	O	O	M2
43	Advanced CC wait	7.2.5.3.7	O	M2	O	M2
44	Advanced CC attributes_T, request	7.2.5.3.8	O	M2	M2	O
45	Advanced CC attributes_T, confirm	7.2.5.3.8	M2	O	O	M2
46	Advanced CC bandwidth_T, request	7.2.5.3.9	O	X	O	O
51	Advanced CC release	7.2.5.3.13	O	M2	M2	M2
52	MAC test force transmit	7.2.5.4.2	-	X	-	-

(continued)

Table D.14 (concluded): Messages in the A-tail field

Messages in the A-tail field						
Item No	Message	Ref.	Sending		Receipt	
			FT Status	LT Status	FT Status	LT Status
53	MAC test loopback data	7.2.5.4.3	-	M	M	-
54	MAC test defeat antenna diversity	7.2.5.4.4	-	M	M	-
55	MAC test force bearer handover	7.2.5.4.5	X	X	I	I
56	MAC test escape	7.2.5.4.6	X	X	I	I
57	MAC test network test	7.2.5.4.7	X	I	I	I
58	MAC test clear test modes	7.2.5.4.8	-	M	M	-
79	Encryption request	7.2.5.7	-	O	O	-
80	Encryption confirm	7.2.5.7	O	-	-	O
81	Encryption grant	7.2.5.7	-	O	O	-
82	B-field setup, first PT transmission	7.2.5.8	-	M3	M3	-
83	MAC control escape	7.2.5.9	O	X	I	O

Table D.15: Messages in the B-tail field

Messages in the B-tail field						
Item No	Message	Ref.	Sending		Receipt	
			FT Status	LT Status	FT Status	LT Status
1	Advanced CC access request	7.3.3.2	O	M3	M3	O
2	Advanced CC bearer handover request	7.3.3.2	-	X	O	-
3	Advanced CC connection handover request	7.3.3.2	O	X	O	O
4	Advanced CC unconfirmed access request	7.3.3.2	O	X	O	O
5	Advanced CC bearer confirm	7.3.3.3	M3	O	O	M3
6	Advanced CC wait	7.3.3.4	O	M3	O	M3
14	Advanced CC release	7.3.3.10	O	M3	M3	M3
30	B-field escape	7.3.8	O	X	I	X

### D.4.3 Message parameters

The slot type shall be set correctly in all message parameters.

The equipment supplier shall provide message parameter details for configuring the LT.

**Table D.16: Parameters for A-field static system information message**

Parameters for A-field static system information message						
Item No	Name of parameter	Ref.	FT Status	LT Status	Values	
					FT Allowed	LT Allowed
1	Normal-reverse	7.2.3.2.2	M	M	0,1	0,1
2	Slot number	7.2.3.2.3	M	M	0-11	0-11
3	Start position	7.2.3.2.4	M	M	0,2	0,2
4	QT escape bit	7.2.3.2.5	M	M	0,1	0,1
5	Number of transceivers	7.2.3.2.6	M	M	0-3	0-3
6	Extended RF carrier information available	7.2.3.2.7	M	M	0,1	0,1
7	RF carriers available	7.2.3.2.8	M	M	1-1023	1-1023
8	Carrier number	7.2.3.2.10	M	M	0-9	0-9
9	Primary receiver scan carrier number	7.2.3.2.12	M	M	0-9	0-9
Slot number, carrier number and primary receive scan carrier number shall be dynamically set by the EUT.						

Table D.17: Parameters for MAC fixed part capability message

Parameters for A-field MAC fixed part capability message						
Item No	Name of parameter	Ref.	FT Status	LT Status	Values	
					FT Allowed	LT Allowed
1	Extended Fixed Part information	7.2.3.4.2	O	M	0,1	0
2	Double slot	7.2.3.4.2	O	M	0,1	0,1
3	Half slot	7.2.3.4.2	O	M	0,1	0,1
4	Full slot	7.2.3.4.2	O	M	0,1	0,1
5	Frequency control	7.2.3.4.2	O	M	0,1	0
6	Page repetition	7.2.3.4.2	O	M	0,1	0
7	C/O setup on dummy bearer allowed	7.2.3.4.2	O	M	0,1	0
8	C/L uplink	7.2.3.4.2	O	M	0,1	0
9	C/L downlink	7.2.3.4.2	O	M	0,1	0
10	Basic A-field setup	7.2.3.4.2	O	M1	0,1	0,1
11	Advanced A-field setup	7.2.3.4.2	O	M2	0,1	0,1
12	B-field setup	7.2.3.4.2	O	M3	0,1	0,1
13	CF messages	7.2.3.4.2	O	M	0,1	0
14	IN minimum delay	7.2.3.4.2	O	M	0,1	0,1
15	IN normal delay	7.2.3.4.2	O	M	0,1	0,1
16	IP error detection	7.2.3.4.2	O	M	0,1	0,1
17	IP error correction	7.2.3.4.2	O	M	0,1	0,1
18	Multibearer connections	7.2.3.4.2	O	M	0,1	0,1

**Table D.18: Parameters for higher layer information fixed part capability message  
(ref. ETS 300 175-5 [5], annex F)**

Parameters for A-field higher layer information fixed part capability message						
Item No	Name of Parameter	Ref.	FT Status	LT Status	Values	
					FT Allowed	LT Allowed
1	ADPCM/G.721 Voice service	a32	O	M	0,1	0,1
2	Public Access Profile (PAP) supported	a33	O	M	0,1	0,1
3	Non-voice circuit switched service	a34	O	M	0,1	0,1
4	Non-voice packet switched service	a35	O	M	0,1	0,1
5	Standard authentication required	a36	O	M	0,1	0,1
6	Standard ciphering supported	a37	O	M	0,1	0
7	Location registration supported	a38	O	M	0,1	0,1
8	SIM services available	a39	O	M	0,1	0,1
9	Non-static Fixed Part (FP)	a40	O	M	0,1	0,1
10	CISS services available	a41	O	M	0,1	0,1
11	CLMS services available	a42	O	M	0,1	0,1
12	COMS services available	a43	O	M	0,1	0,1
13	Access rights requests supported	a44	O	M	0,1	0,1
14	External handover supported	a45	O	M	0,1	0,1
15	Connection handover supported	a46	O	M	0,1	0,1
16	Reserved	a47	O	M	0,1	0,1

## D.4.4 Procedure support

Table D.19: Procedures supported

Procedure supported				
Item No	Name of procedure	Ref.	FT Status	LT Status
1	Dowlink continuous broadcast	9.1.1	M	M
21a	Basic bearer setup	10.5.1.1	M1	M1
22	A-field advanced single bearer setup	10.5.1.3	M2	M2
23	B-field single bearer setup	10.5.1.3	M3	M3
27	Duplex bearer handover procedure	10.6.2	I	X
29	Unacknowledge bearer release	10.7.2.1	M	M
40	Duplex bearer physical channel selection	11.4.1	-	X
41	Double simplex bearer physical channel selection	11.4.1	-	X
42	Simplex bearer physical channel selection	11.4.1	-	X
45	RFP idle receiver scan sequence	11.8	M	M
46	Test message	12	M	M



D.4.5 CSF multiplexing functions

Table D.20: CSF multiplexing functions

CSF multiplexing functions				
Item No	Name of function	Ref.	FT Status	LT Status
1	D-field MAP D80	6.2.1.1	Ca	Cb
2	D-field MAP D32	6.2.1.1	Ca	Cb
3	D-field MAP D08	6.2.1.1	Ca	Cb
4	D-field MAP D00	6.2.1.1	Ca	Cb
5	A-field MAP	6.2.1.2	M	M
6	B-field MAP D80 unprotected	6.2.1.3	Cc	Cd
7	B-field MAP D32 unprotected	6.2.1.3	Cc	Cd
8	B-field MAP D08 unprotected	6.2.1.3	Cc	Cd
9	B-field MAP D80 protected	6.2.1.3	Cc	Cd
10	B-field MAP D32 protected	6.2.1.3	Cc	Cd
11	B-field MAP D08 protected	6.2.1.3	Cc	Cd
12	Tail multiplexer	6.2.2.1	M	M
13	E/U-mux E80	6.2.2.2	Ce	Cf
14	E/U-mux E32	6.2.2.2	Ce	Cf
15	E/U-mux E08	6.2.2.2	Ce	Cf
16	E/U-mux U80a	6.2.2.2	Ce	Cf
17	E/U-mux U32a	6.2.2.2	Ce	Cf
18	E/U-mux U08a	6.2.2.2	Ce	Cf
19	E/U-mux U08a	6.2.2.2	Ce	Cf
20	E/U-mux U32b	6.2.2.2	Ce	Cf
21	E/U-mux U08b	6.2.2.2	Ce	Cf
32	C-mux DS mode 10	6.2.2.3.1	C3g	C3g
37	C-mux FS mode 4	6.2.2.3.1	C3h	C3h

(continued)

Table D.20 (concluded): CSF multiplexing functions

CSF multiplexing functions				
Item No	Name of function	Ref.	FT Status	LT Status
39	C-mux HS mode 1	6.2.2.3.2	C3i	C3i
40	Encryption	6.2.3	O	O
41	Scrambling	6.2.4	M3	M3
42a	A field R-CRC generation	6.2.5.2	M	M
42b	B-field R-CRC generation	6.2.5.2	M3	M3
43a	A-field R-CRC checking	6.2.5.2	M	M
43b	B- field R-CRC checking	6.2.5.2	M3	M3
44	X-CRC generation	6.2.5.4	M	M
45	X-CRC checking	6.2.5.4	O	O
46	Broadcast control function	6.2.6	M	-
For A-field setups (i.e. type 1 and 2): only A-field R-CRC is mandatory. Ca: At least one shall be supported by the EUT. Cb: At least one shall be supported by the LT. Cc: At least one shall be supported by the EUT. Cd: At least one shall be supported by the LT. Ce: At least one shall be supported by the EUT. Cf: At least one shall be supported by the LT. C3g: Mandatory if double slot supported. C3h: Mandatory if full slot supported. C3i: Mandatory if half slot supported.				

#### D.4.6 Timer and counter support

Those timers and counters required by the mandatory procedures are classified as mandatory, (see table D.19).

## Annex E (normative): Measurement of BER

The LT shall use the following method for calculating BER.

In frames counted for synchronisation loss the bit errors for the frame shall be disregarded.

Only whole numbers of frames shall be tested.

The threshold used in the EUT to detect synchronisation shall be the same for BER measurements as for normal operation.

- Let the total number of frames transmitted by the LT be  $\alpha$ .
- Let the number of frames counted with synchronisation loss be  $\beta$ .
- Let the number of bits counted in error be  $\gamma$ .
- Let the number of bits in a frame be  $\zeta$ .

Then:

$$\text{BER} = \frac{\gamma}{\zeta \times (\alpha - \beta)}$$

Over the measurement  $\beta$  shall be less than 5% of  $\alpha$ .

## **Annex F (informative): Procedures for the measurement of synchronisation loss at the EUT by the LT**

### **F.1 Description**

Section 13, Radio receiver testing, requires the Synchronisation loss to be measured within the LT. In order that this can be made possible this annex describes a method by which the EUT can inform the LT when a Synchronisation Error has occurred.

### **F.2 Method**

When a synchronisation error occurs the EUT should either:

- 1) Re-transmit the last received B-field, or
- 2) Transmit all 0's in the B-field;

of the transmit half frame immediately following the loss of synchronisation.

The LT should detect the synchronisation error by using a threshold method on the bit error count for the frame. If the BER calculated for the frame is less than 25% then the BER calculated should go towards the total bit error count for the measurement. If the BER calculated is greater than or equal to 25% then the frame is counted as a synchronisation error and the total bit error count is not incremented.

## History

Document history	
December 1995	First Edition
September 1995	Public Enquiry PE 91: 1995-09-04 to 1995-12-29
April 1996	Converted into Adobe Acrobat Portable Document Format (PDF)