



**E**UROPEAN  
**T**ELECOMMUNICATION  
**S**TANDARD

**DRAFT**  
**prETS 300 926**

December 1996

---

Source: ETSI TC-SMG

Reference: DE/SMG-030269QR

ICS: 33.020

**Key words:** Digital cellular telecommunications system, Global System for Mobile communications (GSM)



**Digital cellular telecommunications system (Phase 2+);  
Voice Broadcast Service (VBS) - Stage 1  
(GSM 02.69 version 5.1.1)**

**ETSI**

European Telecommunications Standards Institute

**ETSI Secretariat**

**Postal address:** F-06921 Sophia Antipolis CEDEX - FRANCE

**Office address:** 650 Route des Lucioles - Sophia Antipolis - Valbonne - FRANCE

**X.400:** c=fr, a=atlas, p=etsi, s=secretariat - **Internet:** secretariat@etsi.fr

Tel.: +33 4 92 94 42 00 - Fax: +33 4 93 65 47 16

---

**Copyright Notification:** No part may be reproduced except as authorized by written permission. The copyright and the foregoing restriction extend to reproduction in all media.

© European Telecommunications Standards Institute 1996. All rights reserved.



## Contents

Foreword .....	5
1 Scope .....	7
2 Normative references .....	7
3 Definitions and abbreviations .....	8
3.1 Definitions .....	8
3.2 Abbreviations .....	8
4 Description .....	9
5 Normal operation with successful outcome.....	12
5.1 Provision .....	12
5.2 Withdrawal .....	12
5.3 Network related service configuration.....	12
5.4 Normal operation for voice broadcast call establishment .....	12
5.5 Charging requirements .....	13
6 Exceptional procedures or unsuccessful outcome.....	13
7 Interaction with GSM services and features.....	13
7.1 Calling Line Identification Presentation (CLIP) .....	13
7.2 Calling Line Identification Restriction (CLIR) .....	13
7.3 Connected Line Identification Presentation (COLP) .....	13
7.4 Connected Line Identification Restriction (COLR) .....	13
7.5 Call Forwarding Unconditional (CFU) .....	13
7.6 Call Forwarding on mobile subscriber Busy (CFB) .....	14
7.7 Call Forwarding on No Reply (CFNRy) .....	14
7.8 Call Forwarding on mobile subscriber Not Reachable (CFNRc) .....	14
7.9 Call Waiting (CW) .....	14
7.10 Call Hold (HOLD) .....	14
7.11 Multi-party Service (MPTY) .....	14
7.12 Closed User Group (CUG).....	14
7.13 Advice of Charge (AoC).....	14
7.14 Barring of All Outgoing Calls (BAOC) .....	14
7.15 Barring of Outgoing International Calls (BOIC).....	15
7.16 Barring of Outgoing International Calls except those directed to the Home PLMN country (BOIC-exHC).....	15
7.17 Barring of All Incoming Calls (BAIC).....	15
7.18 Barring of Incoming Calls when Roaming outside the home PLMN country (BIC-Roam) .	15
7.19 Call Transfer (ECT).....	15
7.20 Completion of Calls to Busy Subscriber (CCBS) .....	15
[7.21 enhanced Multi-Level Precedence and Pre-emption service (eMLPP) .....	15
7.22 Short Message Service (SMS).....	15
8 Interworking considerations.....	15
History.....	17

Blank page

## Foreword

This draft European Telecommunication Standard (ETS) has been produced by the Special Mobile Group (SMG) Technical Committee (TC) of the European Telecommunications Standards Institute (ETSI) and is now submitted for the Unified Approval Procedure phase of the ETSI approval procedure.

This ETS specifies the stage one description of the Voice Broadcast Service (VBS) within the digital cellular telecommunications system.

This ETS is a GSM Technical Specification version 5 and is part of the 1996 release of the GSM Technical Specifications.

The contents of this ETS is subject to continuing work within TC-SMG and may change following formal TC-SMG approval. Should TC-SMG modify the contents of this ETS, it will be resubmitted for UAP by ETSI with an identifying change of release date and an increase in version number as follows:

Version 5.x.y

where:

- y the third digit is incremented when editorial only changes have been incorporated in the specification;
- x the second digit is incremented for all other types of changes, i.e. technical enhancements, corrections, updates, etc.

<b>Proposed transposition dates</b>	
Date of latest announcement of this ETS (doa):	3 months after ETSI publication
Date of latest publication of new National Standard or endorsement of this ETS (dop/e):	6 months after doa
Date of withdrawal of any conflicting National Standard (dow):	6 months after doa

Blank page

## 1 Scope

This European Telecommunication Standard (ETS) specifies the stage one description of the Voice Broadcast Service (VBS) which allows the distribution of speech (or other signals which can be transmitted via the speech codec), generated by a service subscriber, into a predefined geographical area to all or a group of service subscribers located in this area.

[Remark: A similar service might be provided for the distribution of data messages. This service is not treated in the present stage 1 description. However, the principle requirements and realizations should be co-ordinated and synergies with the respective work item on General Packet Radio Service (GPRS) regarded.]

The Voice Broadcast Service (VBS) is applicable to all mobile stations in a certain network and area which have the technical capability and the respective subscription to receive a VBS call.

NOTE: It is not considered as requirement that normal GSM phase 2 mobile stations will be able to be used for this service.

The service is described from the service subscriber's and user's point of view; in particular:

- the procedure for normal operation with successful outcome;
- the action to be taken in exceptional circumstances;
- the interaction with other GSM services and features.

This ETS does not deal with the Man-Machine Interface (MMI) requirements, but makes reference to the appropriate Global System for Mobile communications (GSM) specifications.

This ETS defines a teleservice of the digital cellular telecommunication system GSM. Any interaction with other services and/or networks not dealt within clauses 8 or 9 are outside the scope of this ETS.

## 2 Normative references

This ETS incorporates by dated and undated reference, provisions from other publications. These normative references are cited at the appropriate places in the text and the publications are listed hereafter. For dated references, subsequent amendments to or revisions of any of these publications apply to this ETS only when incorporated in it by the amendment or revision. For undated references, the latest edition of the publication referred to applies.

- |     |  |
|-----|--|
| [1] | GSM 01.04 (ETR 350): "Digital cellular telecommunications system (Phase 2+); Abbreviations and acronyms".  |
| [2] | GSM 02.40: "Digital cellular telecommunications system; Procedures for call progress indications".   |
| [3] | GSM 02.67 (ETS 300 924): "Digital cellular telecommunications system (Phase 2+); enhanced Multi-Level Precedence and Pre-emption service (eMLPP) - Stage 1". |
| [4] | GSM 12.05: (ETS 300 616) "Digital cellular telecommunications system (Phase 2); Subscriber related event and call data".                                     |

## 3 Definitions and abbreviations

### 3.1 Definitions

**network operator:** Entity which provides the network operating elements and resources for the execution of the VBS.

**service provider:** Entity which offers the VBS for subscription. The network operator may be the service provider.

**service subscriber:** Mobile subscriber which subscribes to the VBS.

**voice broadcast call:** An instance of the VBS initiated by a VBS subscriber. This term is used synonymously with the term "VBS call".

**group identification (group ID):** A numerical classification. The maximum number of group IDs which can be defined in one PLMN depends on the maximum number of group call areas defined in this PLMN. The maximum number of group IDs and group call areas shall be  $10^8-1$ , Service subscriber shall be provided with one or up to 50 group IDs.

**dispatcher:** Particular fixed line or mobile users are identified within the network as dispatchers. Dispatchers shall receive all voice broadcast calls to a certain group ID in a group call area (this shall be done automatically by the network). In addition they can initiate voice broadcast calls to a group ID in a group call area.

Dispatchers shall be connected to a voice broadcast call by means of standard links via radio or via an ISDN. They shall be called by their ISDN or MSISDN number, respectively. When dispatchers initiate voice broadcast calls, they shall call a particular MSISDN number which is related to a group ID and group call area. Dispatchers using the GSM network can be located outside of this group call area.

The identities of the dispatchers are exclusively predefined in the network by the service provider. There will be none or up to five dispatchers involved in a particular voice broadcast call.

**destination subscriber:** Service subscriber or dispatcher to which the VBS call is directed.

**calling subscriber:** Service subscriber or dispatcher which invokes the VBS call.

**group call area:** Predefined area composed of one or a cluster of cells, to which a particular VBS call is distributed. The maximum number of group call area IDs which can be defined in one PLMN depends on the maximum number of group IDs defined in this PLMN. The maximum number of group IDs and group call areas shall be  $10^8-1$ , The composition of a group call area is predefined in the network by the service provider. Changing of cell allocations in the network due to operational reasons will need an adaptation of the group call area definition. The group call area may include cells of more than one MSC area and cells of more than one PLMN.

### 3.2 Abbreviations

Abbreviations used in this ETS are listed in GSM 01.04.



## 4 Description

The VBS is defined in the following. Figure 1 gives an explanation of the logical concept of the VBS.

- a) The VBS enables a calling subscriber to send speech unidirectional and simultaneously to all entitled dispatchers and to destination subscribers belonging to a predefined group call area who have a subscription to the applicable group ID.

[Remark: calls with the possibilities of semi-duplex conversation between the service subscribers involved are not subject to the VBS but are treated in an additional stage 1 description on Voice Group Call Service (VGCS).]

- b) The calling subscriber may be any service subscriber which has subscribed to the related group ID and is entitled to establish a voice broadcast call by his subscription or any dispatcher who is entitled for it by his identity which shall be registered in the network.

The destination subscriber may be any service subscriber which has subscribed to the related group ID or any dispatcher who is entitled for it by his identity which is registered in the network.

- c) The broadcast call shall be established in a group call area which is comprised of one or a cluster of cells. Group call areas shall be predefined in the network by the service provider, co-ordinated by the network operator.

In case of a service subscriber initiating a VBS call, the group call area is uniquely identified by the actual cell in which the service subscriber resides at the moment of VBS call initialization and by the called group ID.

A dispatcher initiating a VBS call will be connected to a related predefined group call area. The entitlement of the dispatcher is checked by the network element responsible for the voice broadcast call management by verification of the calling identity. Since a dispatcher may be registered to more than one group call area and group ID an indication of the wanted group call area and group ID has to be given in form of a dedicated address called by the dispatcher.

- d) Destination subscribers are all service subscribers or a group of service subscribers identified by the called group ID which have their present location in the group call area, and preregistered dispatchers. Destination service subscribers shall be notified with the group ID, not by paging the service subscriber individually. Dispatchers shall be called individually with their identity.

Service subscribers which leave the group call area during an on going VBS call cease to be destination subscribers. Service subscribers which enter the group call area during an on going VBS call shall become destination subscribers within 500 ms after reception of the first notification message related to the VBS call.

- e) The calling subscriber shall remain within the voice broadcast call until he terminates the call, loses contact with the network or leaves the group call area. The latter case does not apply to calling subscribers who are dispatchers.
- f) The calling subscriber shall be informed by the network with a suitable indication about the successful establishment of the voice broadcast call so that he can start to speak .

NOTE: A successful establishment means that all broadcast downlink channels are allocated, whether somebody is listening or not, and the related dispatchers are alerted.

- g) Authentication of the destination subscribers is not required.

Authentication of the calling subscriber is optional.

Confidentiality on the radio path is optional.

h) Different levels of priority and pre-emption shall be applied as defined in the corresponding stage 1 description on the enhanced Multi-Level Precedence and Pre-emption service (eMLPP), GSM 02.67.

i) A number of voice broadcast calls may exist simultaneously intended for different groups of destination subscribers in the same group call area.

Parallel voice broadcast calls are possible to the same group of destination subscribers in different, possibly overlapping group call areas.

j) VBS shall also be provided in case of roaming. For this, certain group IDs shall be defined as supra-PLMN group IDs which have to be co-ordinated between the network operators and which shall be known in the networks and in the SIM. A service subscriber which is entitled by his subscription to establish voice broadcast calls while roaming shall only be able to use supra-PLMN group IDs in case of roaming.

k) For certain levels of priorities an acknowledgement of receipt of a voice broadcast call can be required as an application option (e.g. for railway emergency calls) from all or from nominated destination subscribers (the nomination is recorded on the SIM). The acknowledgement itself shall be performed at the end of the voice broadcast call. The acknowledgement shall indicate the time the reception started and the time the reception terminated. The acknowledgement has to be given to a predefined recipient.

l) It shall be possible for a service subscriber to activate or deactivate the voice broadcast reception for different group IDs. The selection list is stored on the SIM corresponding to the subscribed group IDs. It shall be possible to prohibit the deactivation of group IDs used for high priority voice broadcast calls.

Dispatcher which are registered for a certain voice broadcast call and which have also a subscription for VBS with the same group ID as the voice broadcast call for which they are dispatcher shall deactivate this group ID when they are located in the corresponding group call area in order to avoid conflicts between paging for the dispatcher and notifications for the group ID.

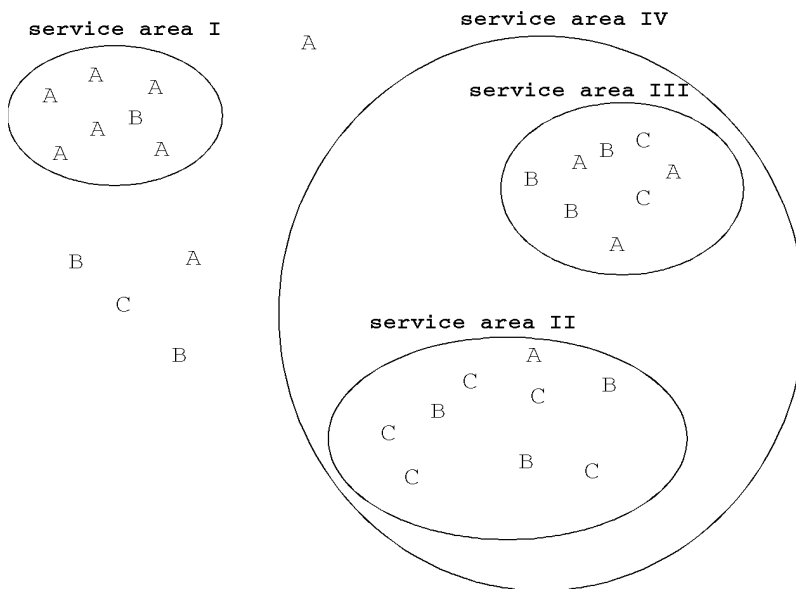
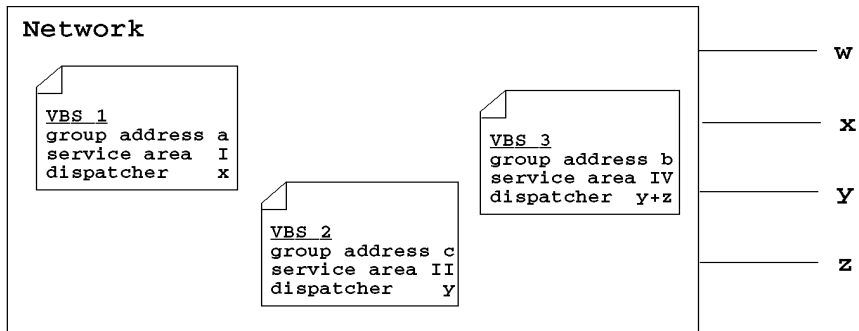

NOTE: VBS1, VBS2, VBS3 = particular voice broadcast calls with the attributes preregistered in the network.

A, B, C, D = service subscriber with group ID a, b, c or d, respectively

I, II, III, IV = group call areas

w, x, y, z = dispatchers connected via normal GSM links or external networks

**Figure 1: Logical concept of the VBS**

## 5 Normal operation with successful outcome

### 5.1 Provision

The VBS is provided to be used by a service subscriber after prior arrangements with the service provider. The provision includes the assignment of group IDs to the service subscriber. A subscription shall not provide more than 50 group IDs to the service subscriber.

The service can be offered with two subscription options:

Subscription option	Value
- subscriber has the capability of initiating voice broadcast calls	- No - Yes
- subscriber has the capability to initiate voice broadcast calls in case of roaming	- No - Yes

### 5.2 Withdrawal

The VBS is withdrawn at the service provider's request or for administrative reasons.

### 5.3 Network related service configuration

The network related service configuration defines the attributes of a particular voice broadcast call which shall be pre-registered in the network by the service provider. This is not related to one specific service subscriber.

The attributes of a particular broadcast call are group ID, group call area composition, a list of dispatcher identities to be connected to this area, a list of dispatchers allowed to initiate voice broadcast calls to this area, the dispatcher identity which shall be used in case of COLP (see subclause 7.3) and dispatcher identities to which an optional acknowledgement can be routed. Changes to the group call area composition shall be co-ordinated with the network operator.

### 5.4 Normal operation for voice broadcast call establishment

The VBS service shall be automatically initiated by the network when a service subscriber or dispatcher dials a particular short code or address at call set-up.

On successful initiation of the VBS, the voice broadcast call shall be established between the calling subscriber and the destination subscribers. The destination subscribers are:

- all service subscribers at any time during the voice broadcast call with the corresponding group ID when located in the group call area, where the group call area is uniquely defined by:
  - the location (radio cell) of the calling subscriber at invocation and group ID if the calling subscriber is a service subscriber;
  - the addressed group call area if the calling subscriber is a dispatcher;
- the preregistered dispatchers related to that group call area and group ID.

The calling subscriber shall be informed by the network with a suitable indication about the successful establishment of the voice broadcast call so that the user can start to speak.

The call can be released by the calling subscriber or by the network (e.g. in case of a higher priority call) or by dispatchers predefined in the network.

Destination subscribers leaving the voice broadcast call for any reason shall not release the on going voice broadcast call.

## 5.5 Charging requirements

No additional requirements are specified. Normal event data according to GSM 12.05 shall be recorded as a network option related to calling subscriber or related to all VBS calls to one group ID in a specific group call area.

## 6 Exceptional procedures or unsuccessful outcome

If a service subscriber wants to establish a voice broadcast call while not subscribed to the service or the network cannot provide the service for some reason, an indication shall be provided to the calling subscriber to notify him with the reason of failure.

If a dispatcher wants to establish a voice broadcast call while not entitled to do it or the network cannot provide the service for some reason, the call shall be rejected. The network shall give an appropriate standard indication according to GSM 02.40 to dispatchers who are GSM subscribers.

If a voice broadcast call cannot be established to all cells and dispatchers in a pre-set time, the call shall be considered established provided that at least the originated cell in case of a service subscriber originated broadcast call or any one cell within the group call area in case of a dispatcher originated broadcast call has been included within this time.

If a cell is excluded from the group call area because of pre-emption, the voice broadcast call is maintained as long as the calling subscriber is not pre-empted.

## 7 Interaction with GSM services and features

### 7.1 Calling Line Identification Presentation (CLIP)

If CLIP is applied, the VBS call number (E.164) - including a VBS indication, the service area ID and the group ID - shall be presented to the dispatchers. In addition the subaddress of the calling party may be used to identify the calling subscriber to the dispatchers.

The receiving mobile stations of the destination subscribers shall display the paged group ID.

### 7.2 Calling Line Identification Restriction (CLIR)

CLIR shall be supported.

The network shall have the possibility to override CLIR or reject a calling subscriber with CLIR active in case of voice broadcast calls.

### 7.3 Connected Line Identification Presentation (COLP)

If COLP is applied, the VBS call number (E.164) - including a VBS indication, the service area ID and the group ID - shall be presented to the calling subscriber. No destination subscriber identities will be presented.

### 7.4 Connected Line Identification Restriction (COLR)

COLR shall be supported. The network shall have the possibility to override COLR in case of voice broadcast calls.

### 7.5 Call Forwarding Unconditional (CFU)

CFU is not applicable to voice broadcast calls of service subscribers when activated, i.e. CFU shall be ignored.

CFU is applicable for dispatchers.

#### **7.6 Call Forwarding on mobile subscriber Busy (CFB)**

CFB is not applicable to voice broadcast calls of service subscribers with CFB active.

CFB is applicable for dispatchers if the voice broadcast call does not have a higher priority than the present call.

#### **7.7 Call Forwarding on No Reply (CFNRy)**

CFNRy is not applicable to voice broadcast calls of service subscribers with CFNRy active.

CFNRy is applicable for dispatchers.

#### **7.8 Call Forwarding on mobile subscriber Not Reachable (CFNRc)**

CFNRc is not applicable to voice broadcast calls of service subscribers with CFNRc active.

CFNRc is applicable for dispatchers.

#### **7.9 Call Waiting (CW)**

CW is not applicable for service subscriber. Instead, as a network option, a notification of paging for other calls shall be given to the service subscribers involved in the voice broadcast call.

CW is applicable for dispatcher.

#### **7.10 Call Hold (HOLD)**

Call hold is not applicable for service subscriber. Instead, a destination service subscriber can leave the voice broadcast call at any time and return to it later-on by user action as defined in item k) of clause 4.

A calling service subscriber cannot leave the voice broadcast call without releasing the call.

The acceptance of a voice broadcast call by a service subscriber while being in a point-to-point call shall release the point-to-point call.

If a voice broadcast call is requested by a service subscriber while being in a point-to-point call, the point-to-point call shall be released.

Call hold is applicable for dispatcher.

#### **7.11 Multi-party Service (MPTY)**

MPTY is not applicable.

#### **7.12 Closed User Group (CUG)**

CUG is not applicable. Being a member of a CUG has no impact on receiving voice broadcast calls.

#### **7.13 Advice of Charge (AoC)**

AoC can be provided to the calling subscriber as network option.

#### **7.14 Barring of All Outgoing Calls (BAOC)**

BAOC is applicable, if subscribed to, with the possible exception of high priority voice broadcast calls.

**7.15 Barring of Outgoing International Calls (BOIC)**

BOIC is not applicable for voice broadcast calls of service subscribers.

BOIC is applicable for dispatcher.

**7.16 Barring of Outgoing International Calls except those directed to the Home PLMN country (BOIC-exHC)**

BOIC-exHC is not applicable for voice broadcast calls of service subscriber (see subclause 7.15).

BOIC-exHC is applicable for dispatcher.

**7.17 Barring of All Incoming Calls (BAIC)**

VBS calls shall override BAIC if the corresponding group ID is activated on the SIM.

**7.18 Barring of Incoming Calls when Roaming outside the home PLMN country (BIC-Roam)**

VBS calls shall override BIC-Roam if the corresponding group ID is activated on the SIM.

**7.19 Call Transfer (ECT)**

Call transfer is not applicable for service subscribers.

Call transfer is applicable for dispatchers.

**7.20 Completion of Calls to Busy Subscriber (CCBS)**

CCBS is not applicable for voice broadcast calls towards busy subscribers.

CCBS is applicable if a calling subscriber or a dispatcher involved in a voice broadcast call is called.

**[7.21 enhanced Multi-Level Precedence and Pre-emption service (eMLPP)**

Different priorities with corresponding set-up procedures are applicable as defined in the stage 1 description on eMLPP, GSM 02.67.]

**7.22 Short Message Service (SMS)**

Sending and reception of short messages is not possible for destination service subscribers.

**8 Interworking considerations**

No specific requirements are identified.

## History

Document history			
December 1996	Unified Approval Procedure	UAP 61:	1996-12-16 to 1997-04-11