



EUROPEAN
TELECOMMUNICATION
STANDARD

ETS 300 833

June 1999

Source: TM

Reference: DE/TM-04036

ICS: 33.020

Key words: antenna, point-to-point, transmission, DRRS, radio

**Fixed Radio Systems;
Point to Point Antennas;
Antennas for point-to-point fixed radio systems
operating in the frequency band 3 GHz to 60 GHz**

ETSI

European Telecommunications Standards Institute

ETSI Secretariat

Postal address: F-06921 Sophia Antipolis CEDEX - FRANCE

Office address: 650 Route des Lucioles - Sophia Antipolis - Valbonne - FRANCE

Internet: secretariat@etsi.fr - <http://www.etsi.org>

Tel.: +33 4 92 94 42 00 - Fax: +33 4 93 65 47 16

Copyright Notification: No part may be reproduced except as authorized by written permission. The copyright and the foregoing restriction extend to reproduction in all media.

© European Telecommunications Standards Institute 1999. All rights reserved.

Contents

Foreword	5
Introduction	5
1 Scope.....	7
2 References.....	7
3 Definitions, symbols and abbreviations.....	7
3.1 Definitions.....	7
3.2 Symbols.....	8
3.3 Abbreviations.....	9
4 Frequency ranges	9
5 Classification of antennas	9
6 Electrical characteristics	9
6.1 Radiation Pattern Envelope (RPE)	10
6.2 Cross-Polar Discrimination (XPD)	29
6.3 Antenna gain	30
7 Conformance tests.....	30
Annex A (informative): Additional information.....	31
A.1 Mechanical characteristics.....	31
A.1.1 Environmental characteristics	31
A.1.2 Antenna stability	31
A.2 Antenna input connectors	31
A.3 Return loss at the input ports.....	31
A.4 Inter-port isolation	32
A.5 Antenna labelling.....	32
Annex B (informative): Bibliography.....	33
History	34

Blank page

Foreword

This European Telecommunication Standard (ETS) has been produced by the Transmission and Multiplexing (TM) Technical Committee of the European Telecommunications Standards Institute (ETSI).

Transposition dates	
Date of adoption of this ETS:	4 June 1999
Date of latest announcement of this ETS (doa):	30 September 1999
Date of latest publication of new National Standard or endorsement of this ETS (dop/e):	31 March 2000
Date of withdrawal of any conflicting National Standard (dow):	31 March 2000

Introduction

The purpose of this ETS is to define only those antenna parameters necessary to ensure optimum frequency co-ordination between communication services in the frequency range 3 GHz to 60 GHz. Additional parameters appropriate to system implementation may be subject to agreement between the equipment purchaser and supplier. Further guidance is provided in annex A.

Blank page

1 Scope

This European Telecommunication Standard (ETS) addresses the minimum requirements for single main beam, linear polarization, directional antennas to be adopted in conjunction with Point-to-Point (P-P) systems operating in the frequency range 3 GHz to 60 GHz.

Single polarization antennas, dual polarization antennas, dual band/single polarized antennas and dual band/dual polarization antennas are considered.

A regulatory authority may impose tighter requirements than the minimum values given in this ETS, in order to maximize the use of the scarce spectrum resources.

2 References

This ETS incorporates by dated or updated reference, provisions from other publications. These normative references are cited at the appropriate place in the text, and the publications are listed hereafter. For dated references, subsequent amendments to, or revisions of, any of these publications apply to this ETS only when incorporated in it by amendment or revision. For undated references, the latest edition of the publication referred to applies.

- [1] WARC 1992 Final Acts: "Final Acts of the World Administrative Radio Conference for dealing with frequency allocations in certain parts of the spectrum".
- [2] ITU-R Recommendation F.746-2 (REVISED): "Radio-frequency channel arrangements for radio-relay systems".
- [3] IEC 60835-2-2 (1994): "Methods of measurement for equipment used in digital microwave transmission systems; Part 2: Measurements on terrestrial radio-relay systems - Section 2: Antenna".
- [4] EN 301 126-1: "Fixed Radio Systems; Conformance testing; Part 1: Point-to-Point equipments - Definitions, general requirements and test procedures".
- [5] IEC 60154-1: "Flanges for waveguides. Part 1: General requirements".
- [6] IEC 60154-2: "Flanges for waveguides. Part 2: Relevant specifications for flanges for ordinary rectangular waveguides".
- [7] IEC 60169-1 and applicable sub-parts: "Radio-frequency connectors".

3 Definitions, symbols and abbreviations

3.1 Definitions

For the purposes of this ETS, the following definitions apply:

antenna inter-port isolation: it is the ratio in dB of the power level applied to one port of a multi-port antenna to the power level received in any other port of the same antenna as function of frequency

antennas: that part of the transmitting or receiving system that is designed to radiate and/or receive electromagnetic waves

co-polar pattern: diagram representing the radiation pattern of the antenna under test when the reference antenna is similarly polarized, scaled in dBi or dB relative to the measured antenna gain

cross-polar discrimination: difference in dB between the co-polarized main beam gain and the cross-polarized signal measured within a defined region

cross-polar pattern: diagram representing the radiation pattern of the antenna under test when the reference antenna is orthogonally polarized, scaled in dBi or dB relative to the measured antenna gain

frequency band: frequency band of an antenna is the band of frequencies over which the performance characteristics of the antenna are within specified limits

gain: ratio of the radiation intensity, in the main beam axis to the radiation intensity that would be obtained if the power accepted by the antenna were radiated isotropically. Value measured in dBi

half power beamwidth: angle, relative to the main beam axis, between the two directions at which the measured co-polar pattern is 3 dB below the value on the main beam axis

input port(s): flange(s) or connector(s) through which access to the antenna system is provided. This is shown in the following figure 1 at points D and D'

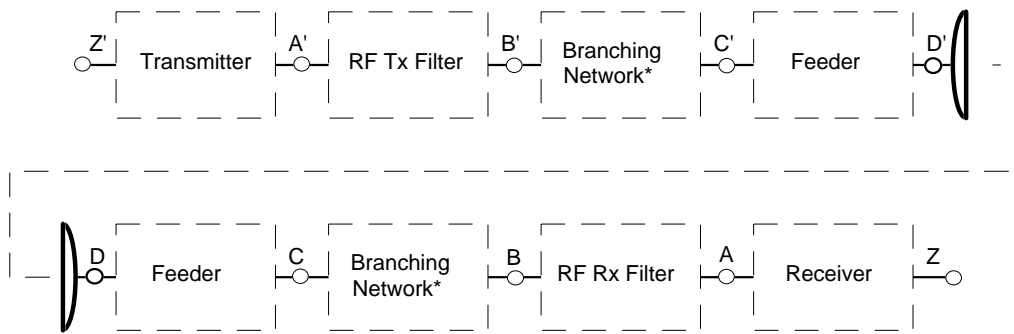

NOTE: The points shown above are reference points only; points B, C and D, B', C' and D' may coincide.

Figure 1: System block diagram

isotropic radiator: hypothetical, lossless antenna having equal radiation intensity in all directions

main beam axis: direction for which the radiation pattern intensity is the maximum

main beam: radiation lobe containing the direction of maximum radiation

radiation pattern envelope: envelope below which the radiation pattern shall fit

radiation pattern: diagram relating power flux density at a constant distance from an antenna to direction relative to the antenna main beam axis

radome: cover of dielectric material, intended for protecting an antenna from the effects of the physical environment

3.2 Symbols

For the purposes of this ETS, the following symbols apply:

dB	decibel
dBi	decibels relative to an isotropic radiator
GHz	GigaHertz

3.3 Abbreviations

For the purposes of this ETS, the following abbreviations apply:

HPBW	Half Power BeamWidth
P-P	Point-to-Point
RL	Return Loss
RPE	Radiation Pattern Envelope
VSWR	Voltage Standing Wave Ratio
WARC	World Administrative Radio Conference
XPD	Cross-Polar Discrimination

4 Frequency ranges

This ETS applies to sub-bands within 3 GHz to 60 GHz frequency band. Fixed link frequency allocations are in accordance with the WARC 1992 Final Acts [1] as given in ITU-R Recommendation F.746-2 [2] and other frequency plans.

For the purposes of this ETS, the overall frequency range 3 GHz to 60 GHz is divided into six frequency ranges as follows:

Range 1:	3 GHz to 14 GHz;
Range 2:	14 GHz to 20 GHz;
Range 3:	20 GHz to 24 GHz;
Range 4:	24 GHz to 30 GHz;
Range 5:	30 GHz to 47 GHz;
Range 6:	47 GHz to 60 GHz.

5 Classification of antennas

With respect to antenna gain, two gain categories are applicable:

Gain category 1: those antennas which require low gain for co-ordination purposes;

Gain category 2: those antennas which require high gain for co-ordination purposes.

With respect to Radiation Pattern Envelope (RPE), four classes have been identified:

Class 1: those antennas required for use in networks where there is a low interference potential;

Class 2: those antennas required for use in networks where there is a high interference potential;

Class 3: those antennas required for use in networks where there is a very high interference potential;

Class 4: those antennas required for use in networks where there is an extremely high interference potential.

With respect to cross-Polar Discrimination (XPD), two XPD performance categories have been identified (refer to subclause 6.2, table 1):

XPD category 1: those antennas required to have standard cross-polar discrimination;

XPD category 2: those antennas required to have high cross-polar discrimination.

6 Electrical characteristics

The antenna manufacturer shall state, for each antenna type, the frequency band of operation and antenna gain at least at the frequency band edges and at mid-band. An antenna which employs a radome shall meet the requirements of this ETS with the radome in place.

The antenna system shall radiate a linear (single or dual) polarized wave.

The method of measurement shall be in accordance to IEC 60835-2-2 [3].

6.1 Radiation Pattern Envelope (RPE)

RPE(s) for each class are included, in order to present the maximum flexibility to administrations for optimized co-ordination.

The co-polar and cross-polar radiation pattern measured in the azimuth plane for both polarizations, shall not exceed the RPE(s) defined in the following list:

Range 1:

Class 1: figure 2a);

Class 2: figure 2b);

Class 3: figure 2c);

Class 4: figure 2d).

Range 2:

Class 1: figure 3a);

Class 2: figure 3b);

Class 3: figure 3c).

Range 3:

Class 1: figure 4a);

Class 2: figure 4b);

Class 3: figure 4c).

Range 4:

Class 1: figure 5a);

Class 2: figure 5b).

Range 5:

Class 1: figure 6a);

Class 2: figure 6b);

Class 3: figure 6c), vertically polarized only.

Range 6:

Class 1: figure 7a);

Class 2: figure 7b);

Class 3: figure 7c), vertically polarized only.

Frequency range 1 3 - 14 GHz

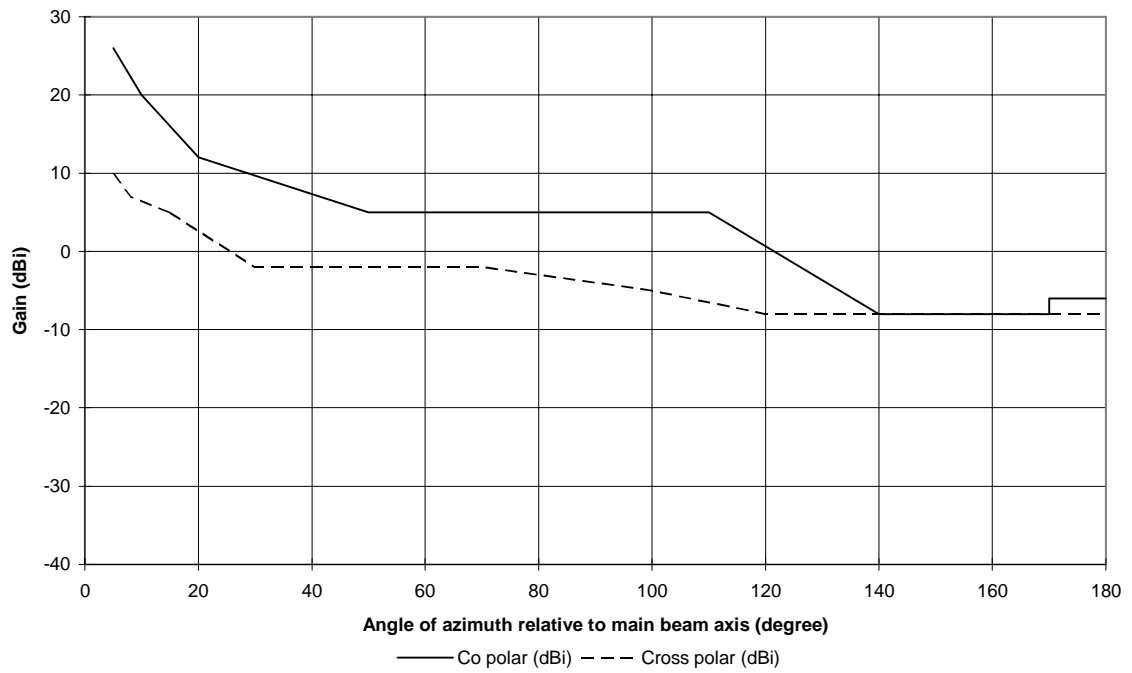

Angle (degrees)	Co-polar (dBi)	Angle (degrees)	Cross-polar (dBi)
5	26	5	10
10	20	8	7
20	12	15	5
50	5	30	-2
110	5	70	-2
140	-8	100	-5
170	-8	120	-8
170	-6	180	-8
180	-6		

Figure 2a): RPEs for class 1 antennas in the frequency range 1

Frequency range 1 3 - 14 GHz

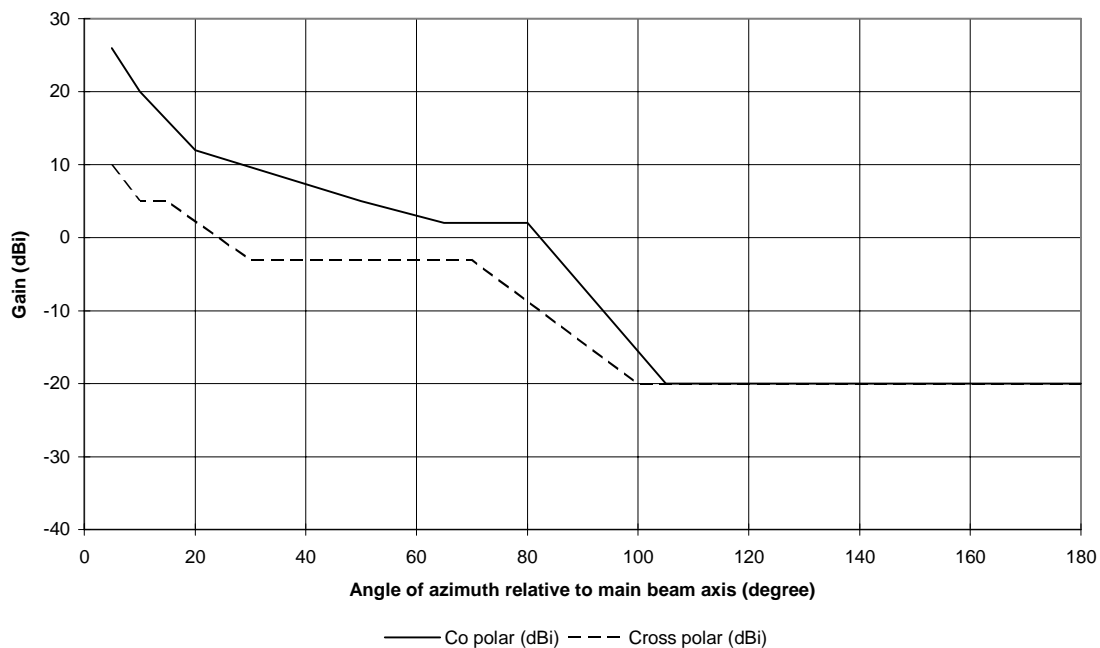

Angle (degrees)	Co-polar (dBi)	Angle (degrees)	Cross-polar (dBi)
5	26	5	10
10	20	10	5
20	12	15	5
50	5	30	-3
65	2	70	-3
80	2	100	-20
105	-20	180	-20
180	-20		

Figure 2b): RPEs for class 2 antennas in the frequency range 1

Frequency range 1 3 - 14 GHz

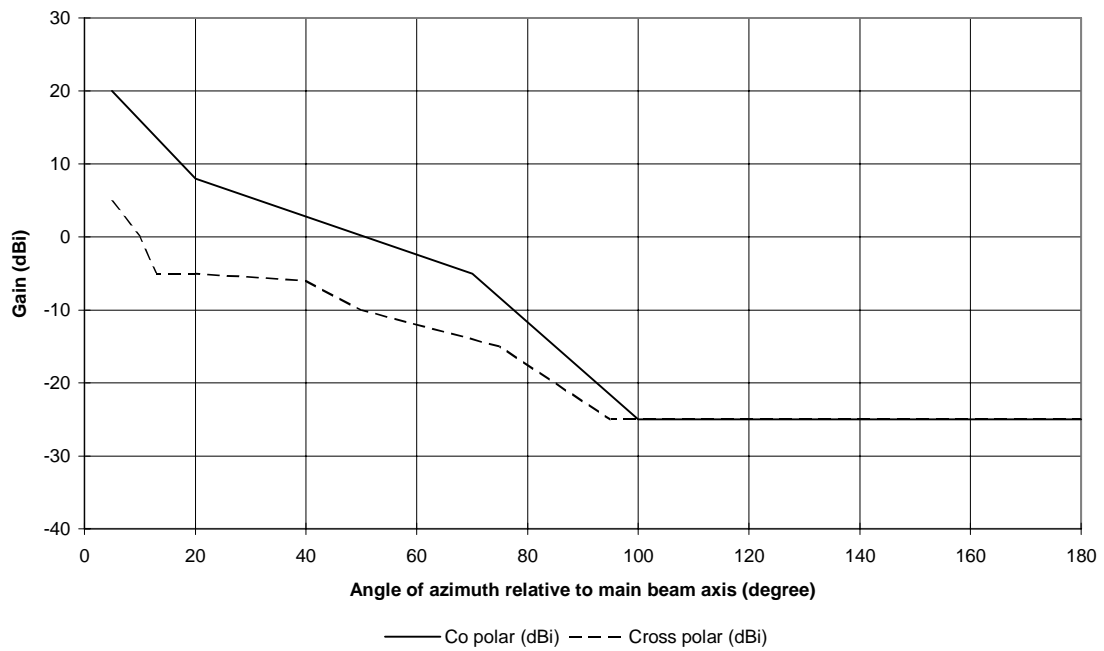

Angle (degrees)	Co-polar (dBi)	Angle (degrees)	Cross-polar (dBi)
5	20	5	5
20	8	10	0
70	-5	13	-5
100	-25	20	-5
180	-25	40	-6
		50	-10
		75	-15
		95	-25
		180	-25

Figure 2c): RPEs for class 3 antennas in the frequency range 1

Frequency range 1 3 - 14 GHz

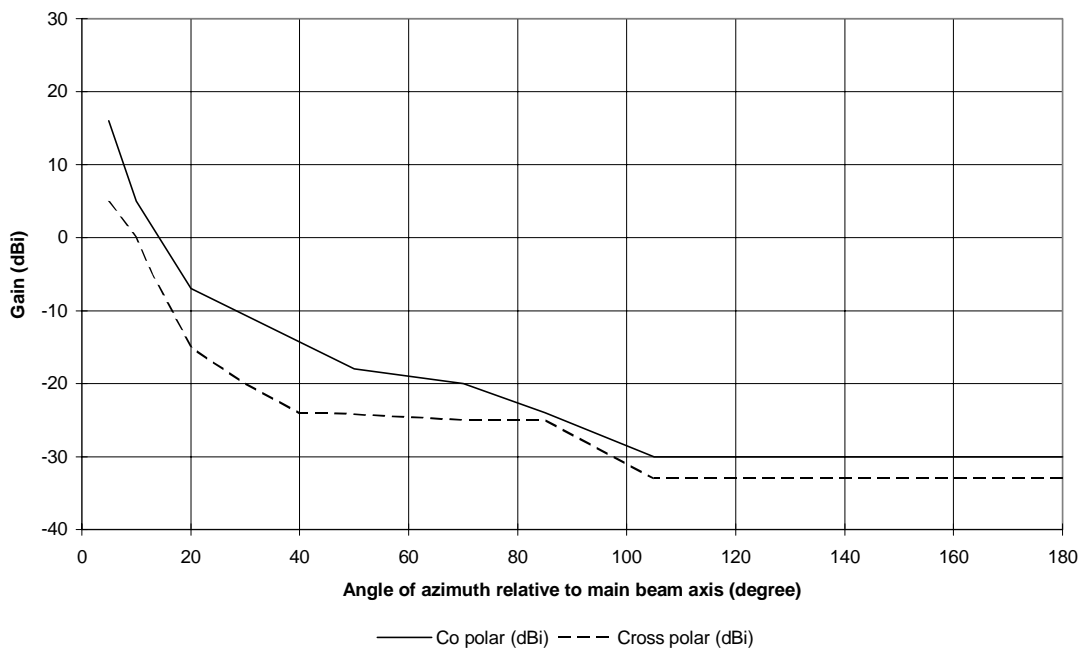

Angle (degrees)	Co-polar (dBi)	Angle (degrees)	Cross-polar (dBi)
5	16	5	5
10	5	10	0
20	-7	13	-5
50	-18	20	-15
70	-20	30	-20
85	-24	40	-24
105	-30	45	-24
180	-30	70	-25
		85	-25
		105	-33
		180	-33

Figure 2d): RPEs for class 4 antennas in the frequency range 1

Frequency range 2 14 - 20 GHz

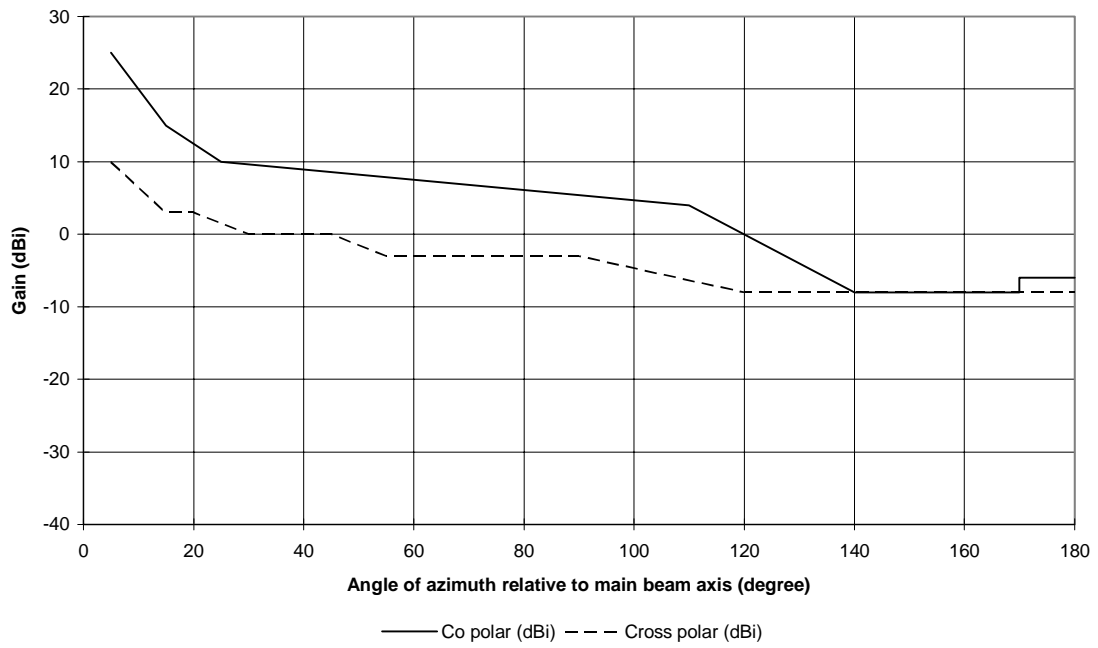

Angle (degrees)	Co-polar (dBi)	Angle (degrees)	Cross-polar (dBi)
5	25	5	10
15	15	15	3
25	10	20	3
110	4	30	0
140	-8	45	0
170	-8	55	-3
170	-6	90	-3
180	-6	120	-8
		180	-8

Figure 3a): RPEs for class 1 antennas in the frequency range 2

Frequency range 2 14 - 20 GHz

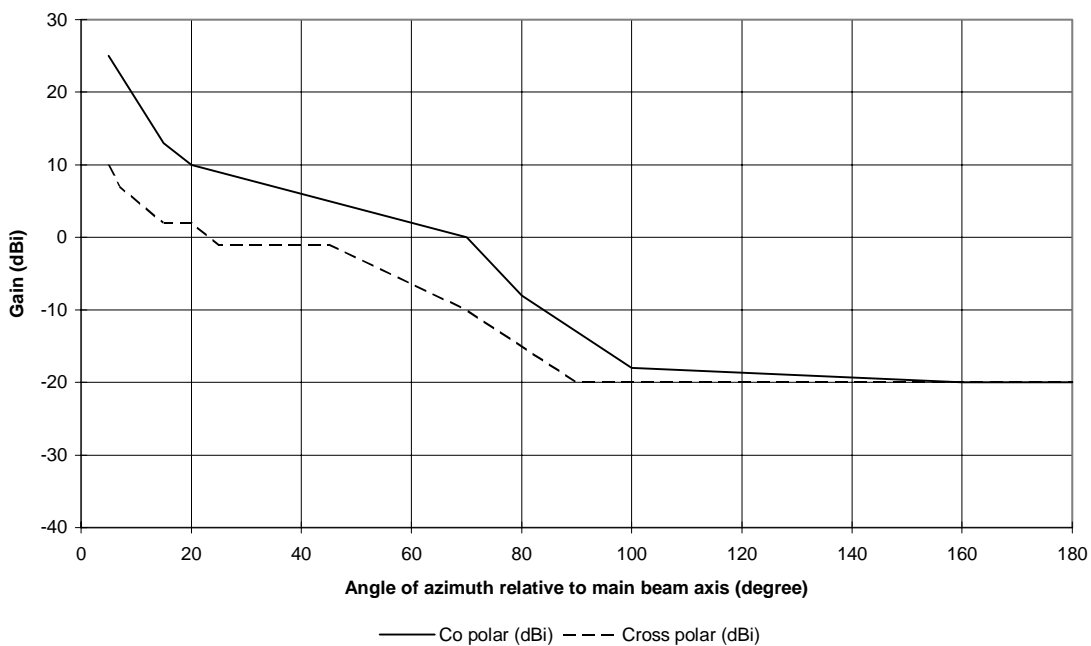

Angle (degrees)	Co-polar (dBi)	Angle (degrees)	Cross-polar (dBi)
5	25	5	10
15	13	7	7
20	10	15	2
70	0	20	2
80	-8	25	-1
100	-18	45	-1
160	-20	70	-10
180	-20	90	-20
		180	-20

Figure 3b): RPEs for class 2 antennas in the frequency range 2

Frequency range 2 14 - 20 GHz

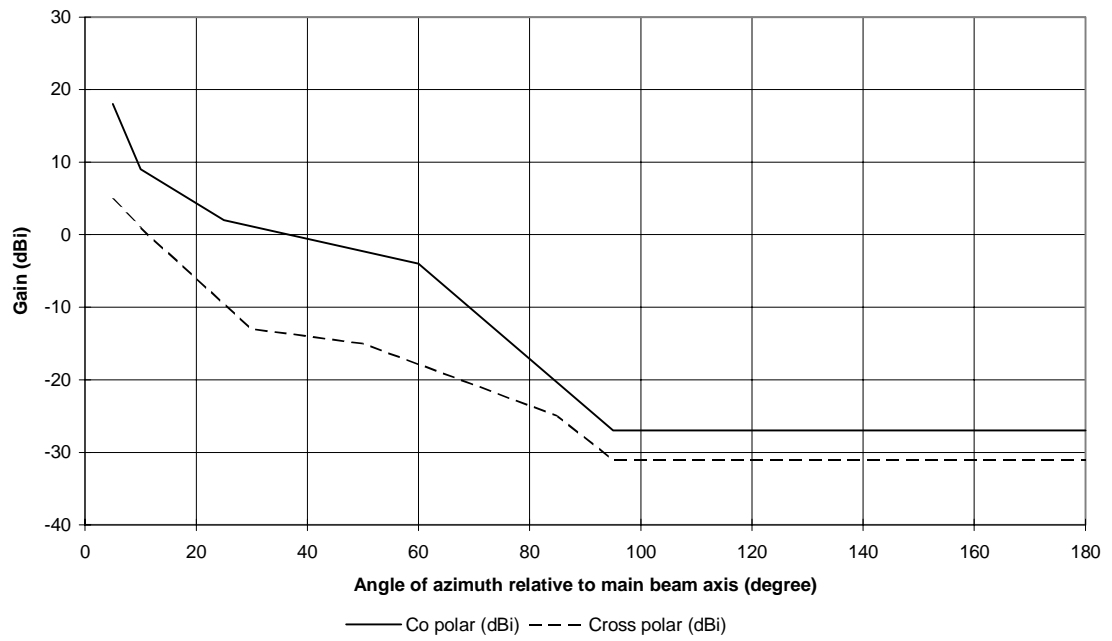
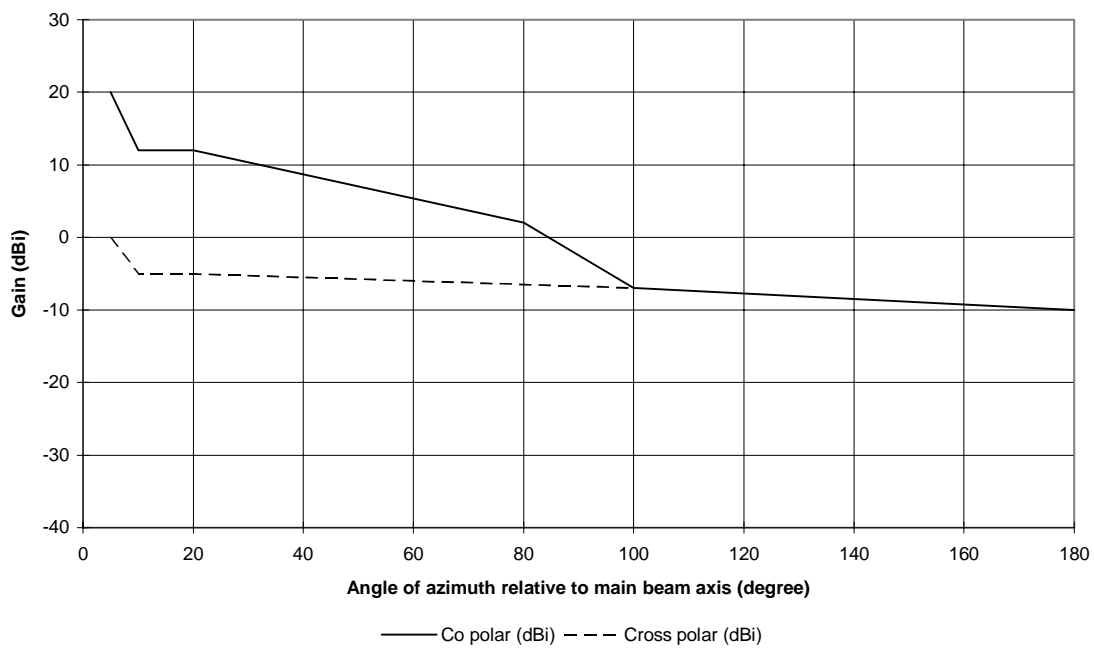

Figure 3c): RPEs for class 3 antennas in frequency range 2

Frequency range 3 20 - 24 GHz



Angle (degrees)	Co-polar (dBi)	Angle (degrees)	Cross-polar (dBi)
5	20	5	0
10	12	10	-5
20	12	20	-5
80	2	100	-7
100	-7	180	-10
180	-10		

Figure 4a): RPEs for antennas class 1 in the frequency range 3

Frequency range 3 20 - 24 GHz

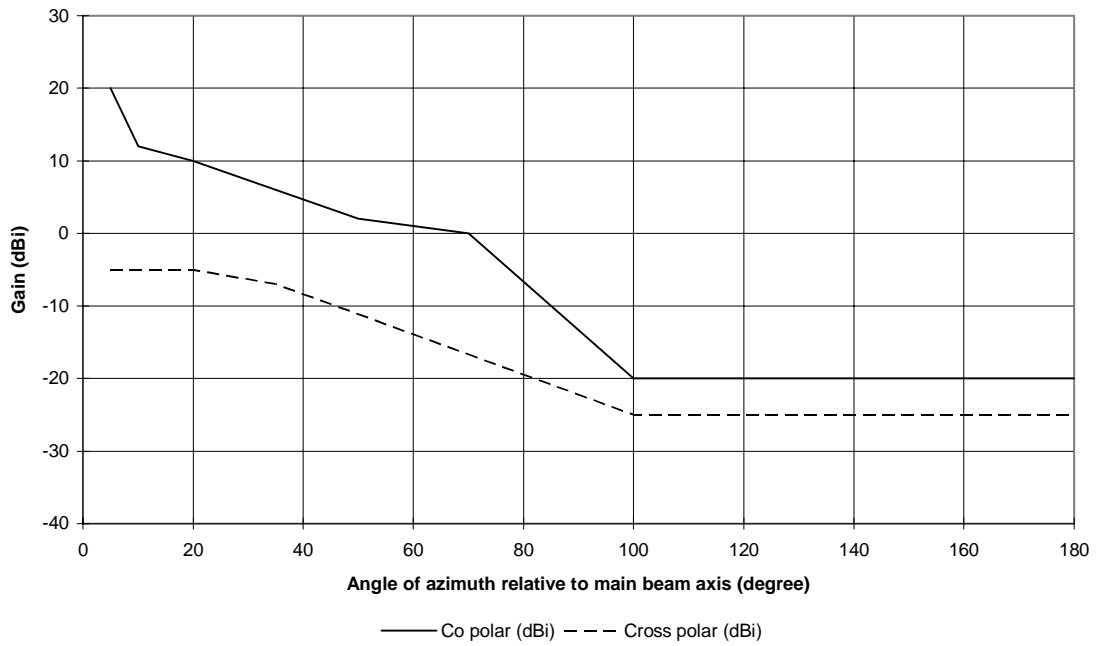

Angle (degrees)	Co-polar (dBi)	Angle (degrees)	Cross-polar (dBi)
5	20	5	-5
10	12	20	-5
20	10	35	-7
50	2	100	-25
70	0	180	-25
100	-20		
180	-20		

Figure 4b): RPEs for class 2 antennas in the frequency range 3

Frequency range 3 20 - 24 GHz

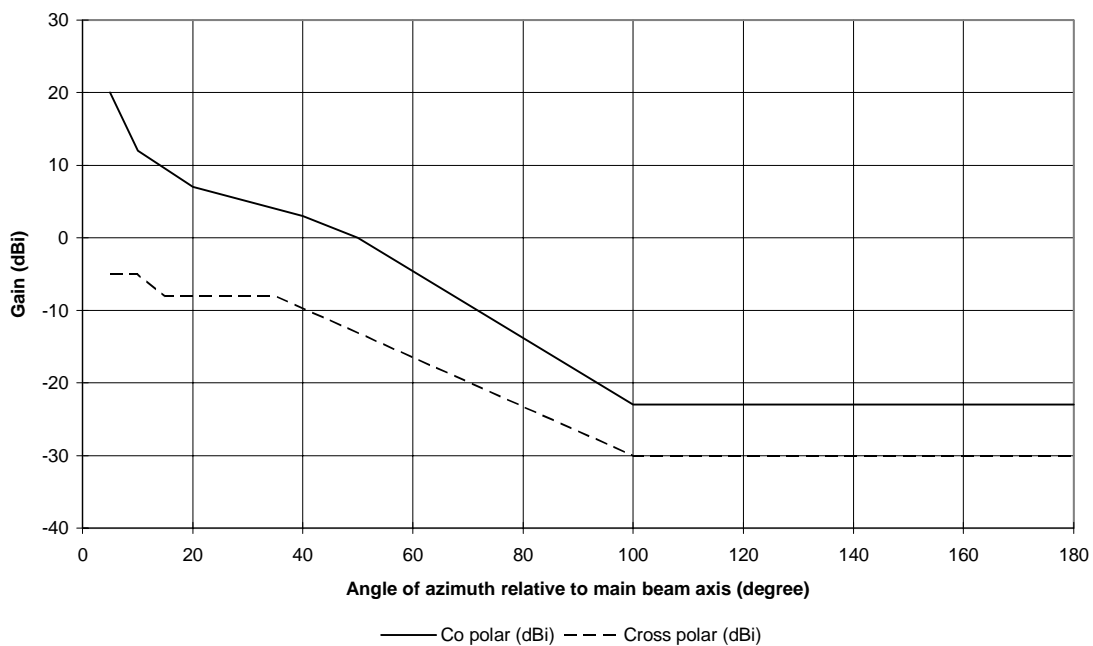

Angle (degrees)	Co-polar (dBi)	Angle (degrees)	Cross-polar (dBi)
5	20	5	-5
10	12	10	-5
20	7	15	-8
40	3	35	-8
50	0	100	-30
100	-23	180	-30
180	-23		

Figure 4c): RPEs for class 3 antennas in the frequency range 3

Frequency range 4 24 - 30 GHz

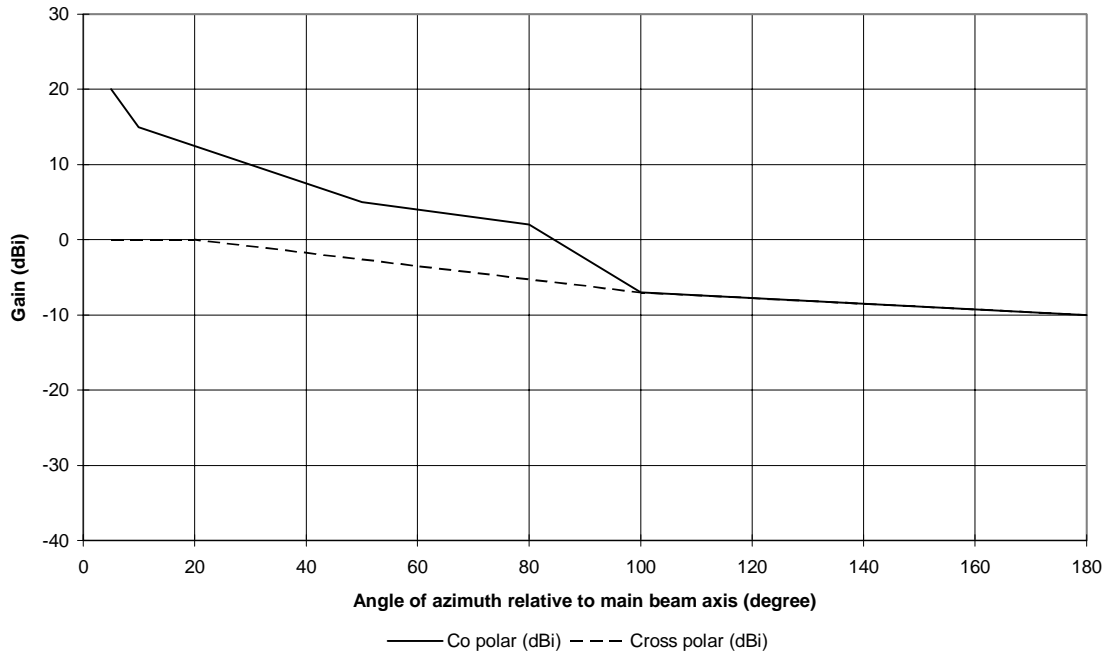

Angle (degrees)	Co-polar (dBi)	Angle (degrees)	Cross-polar (dBi)
5	20	5	0
10	15	20	0
50	5	100	-7
80	2	180	-10
100	-7		
180	-10		

Figure 5a): RPEs for class 1 antennas in the frequency range 4

Frequency range 4 24 - 30 GHz

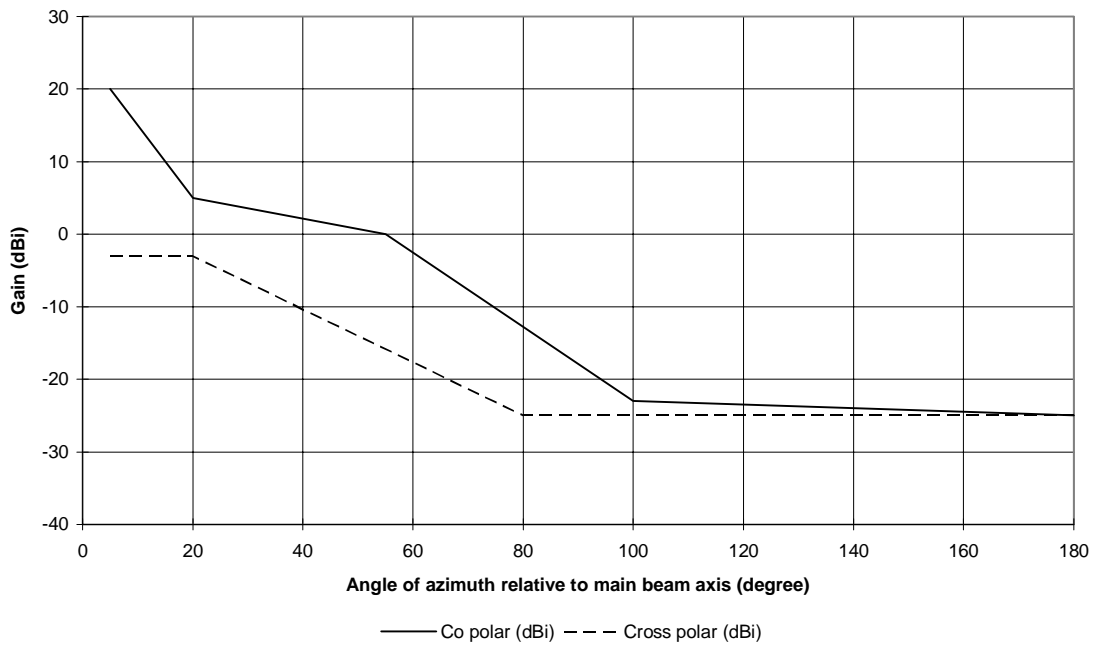

Angle (degrees)	Co-polar (dBi)	Angle (degrees)	Cross-polar (dBi)
5	20	5	-3
20	5	20	-3
55	0	80	-25
100	-23	180	-25
180	-25		

Figure 5b): RPEs for class 2 antennas in the frequency range 4

Frequency range 5 30 - 47 GHz

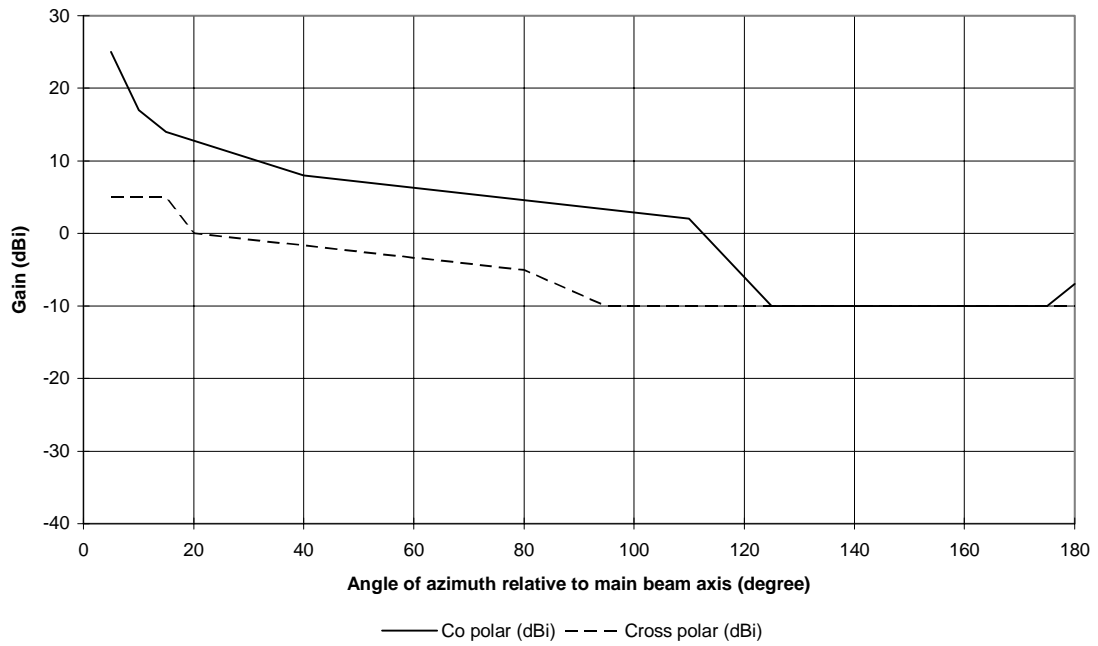

Angle (degrees)	Co-polar (dBi)	Angle (degrees)	Cross-polar (dBi)
5	25	5	5
10	17	15	5
15	14	20	0
40	8	80	-5
110	2	95	-10
125	-10	180	-10
175	-10		
180	-7		

Figure 6a): RPEs for class 1 antennas in the frequency range 5

Frequency range 5 30 - 47 GHz

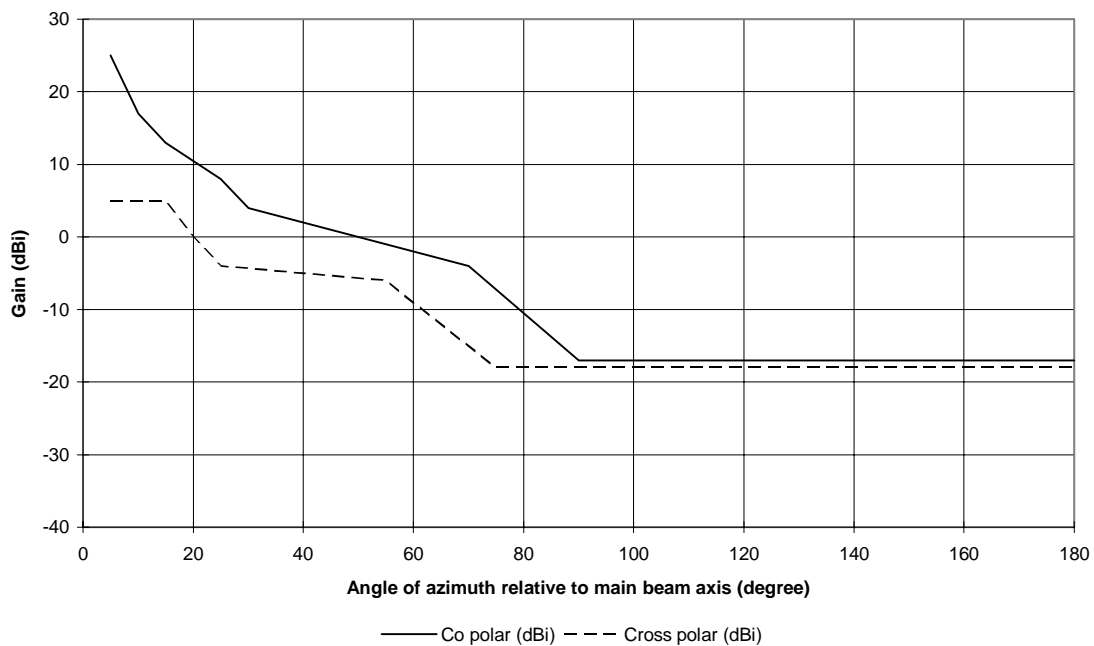

Angle (degrees)	Co-polar (dBi)	Angle (degrees)	Cross-polar (dBi)
5	25	5	5
10	17	15	5
15	13	20	0
25	8	25	-4
30	4	55	-6
70	-4	75	-18
90	-17	180	-18
180	-17		

Figure 6b): RPEs for class 2 antennas in the frequency range 5

Frequency range 5 30 - 47 GHz

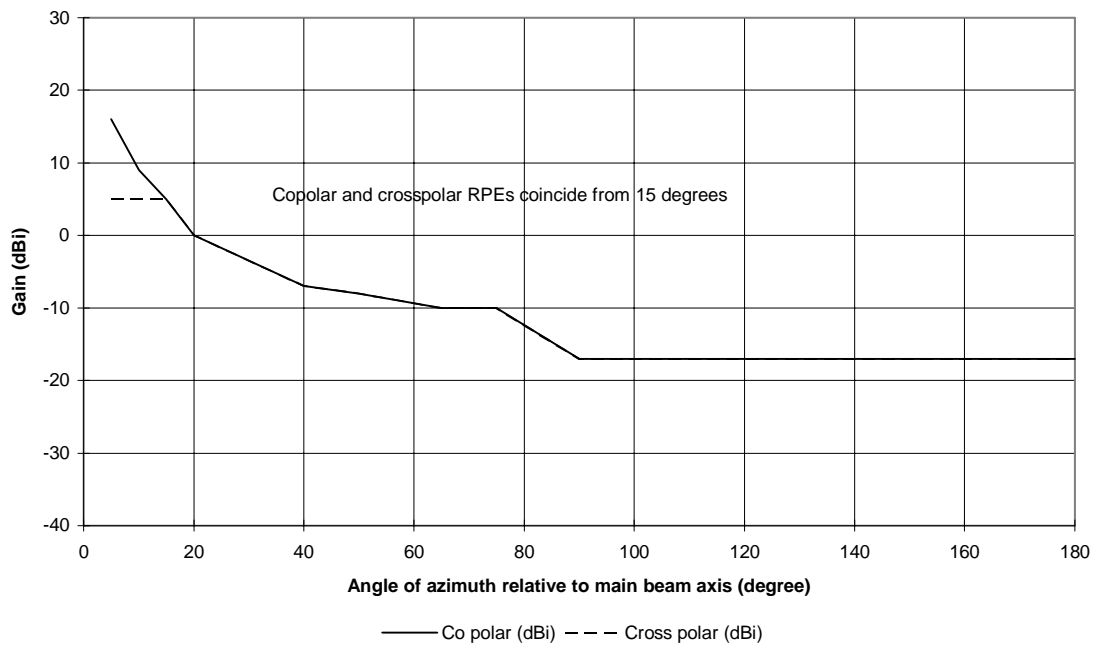

Angle (degrees)	Co-polar (dBi)	Angle (degrees)	Cross-polar (dBi)
5	16	5	5
10	9	15	5
15	5	20	0
20	0	40	-7
40	-7	50	-8
50	-8	65	-10
65	-10	75	-10
75	-10	90	-17
90	-17	180	-17
180	-17		

Figure 6c): RPEs for class 3 antennas in the frequency range 5, vertically polarized only

Frequency range 6 47 - 60 GHz

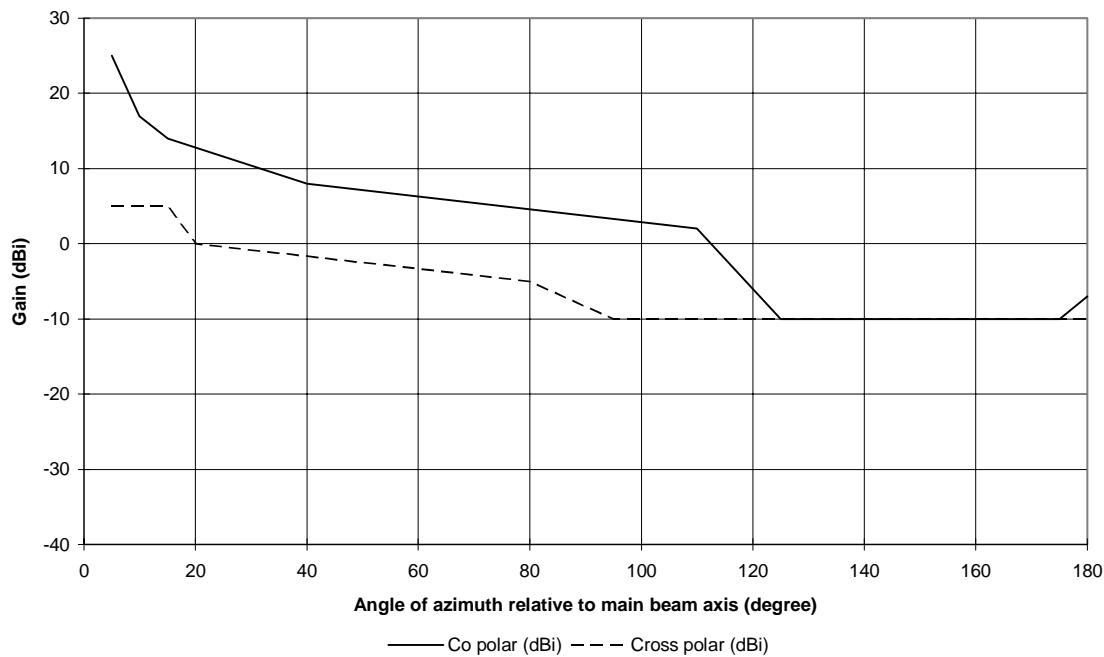

Angle (degrees)	Co-polar (dBi)	Angle (degrees)	Cross-polar (dBi)
5	25	5	5
10	17	15	5
15	14	20	0
40	8	80	-5
110	2	95	-10
125	-10	180	-10
175	-10		
180	-7		

Figure 7a): RPEs for class 1 antennas in the frequency range 6

Frequency range 6 47 - 60 GHz

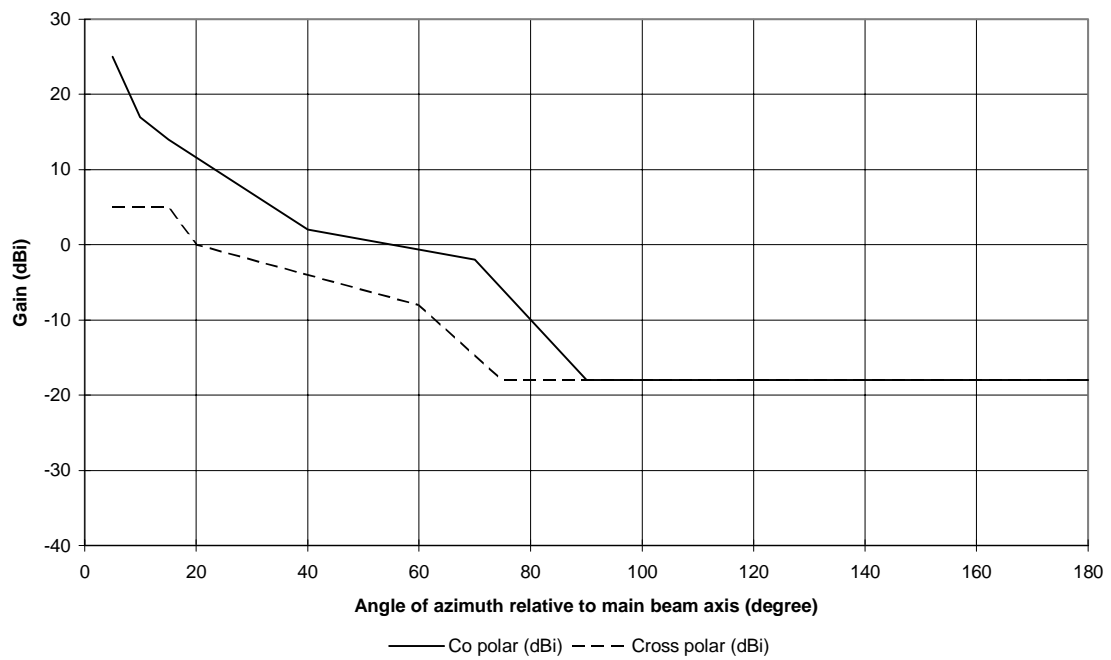

Angle (degrees)	Co-polar (dBi)	Angle (degrees)	Cross-polar (dBi)
5	25	5	5
10	17	15	5
15	14	20	0
40	2	60	-8
70	-2	75	-18
90	-18	180	-18
180	-18		

Figure 7b): RPEs for class 2 antennas in the frequency range 6

Frequency range 6 47 - 60 GHz

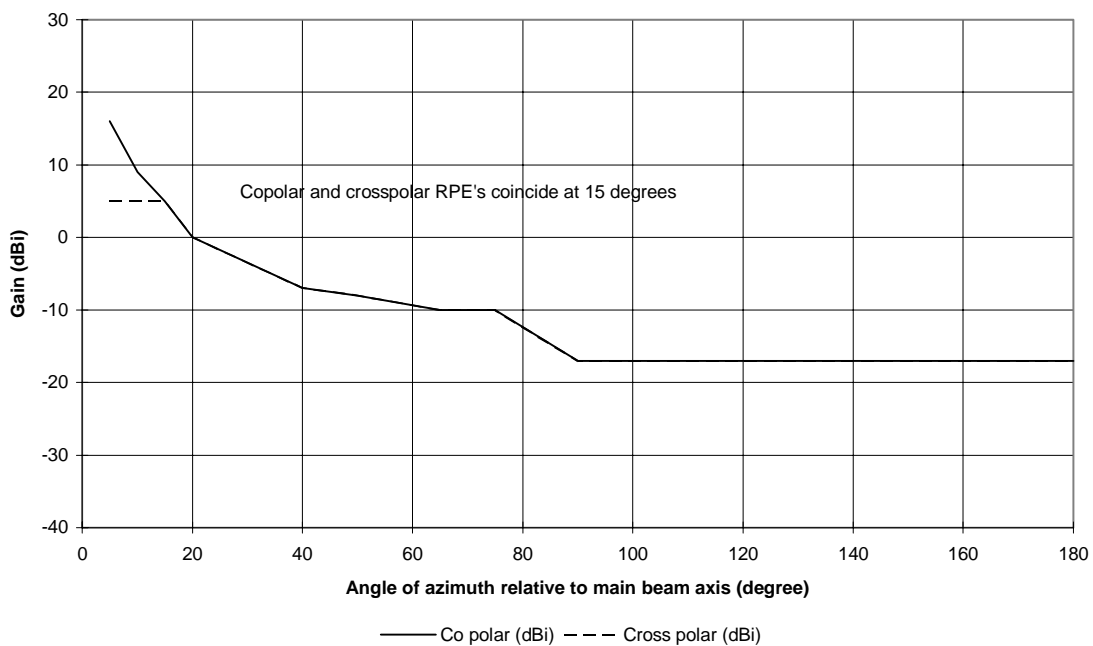

Angle (degrees)	Co-polar (dBi)	Angle (degrees)	Cross-polar (dBi)
5	16	5	5
10	9	15	5
15	5	20	0
20	0	40	-7
40	-7	50	-8
50	-8	65	-10
65	-10	75	-10
75	-10	90	-17
90	-17	180	-17
180	-17		

Figure 7c): RPEs for class 3 antennas in the frequency range 6, vertically polarized only

6.2 Cross-Polar Discrimination (XPD)

The XPDs corresponding to the RPEs referenced in subclause 6.1 shall be equal to or higher than those values defined in table 1.

In figures 8 and 9, masks are given for XPD measurements around the main beam axis.

Table 1: XPD values corresponding to RPE values in subclause 6.1

Frequency ranges	Standard XPD (dB) (note 1)	High XPD (dB)	
		(Referred to figure 8)	(Referred to figure 9)
Range 1			35
	27	35	40 (note 2)
Range 2	27	34	34
Range 3	27	34	34
Range 4	27	34	34
Range 5	27	30	30
Range 6	27	n.a.	n.a.
NOTE 1:	With respect to the azimuthal cut within the 1 dB co-polarized main beam axis.		
NOTE 2:	Referred to region A in figure 9.		
NOTE 3:	n.a. = not applicable.		

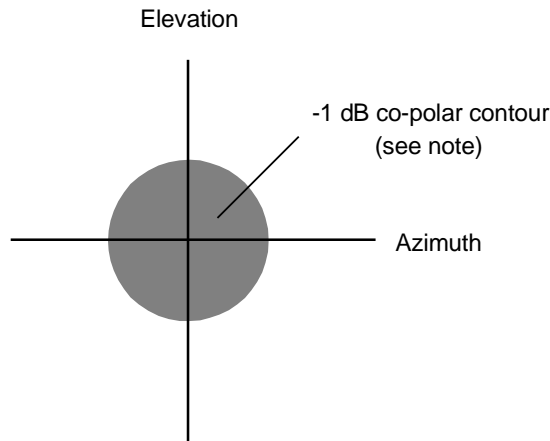

NOTE: For the dual band antennas -1 dB contour for highest frequency band shall be used.

Figure 8: Mask for XPD measurements around the main beam axis

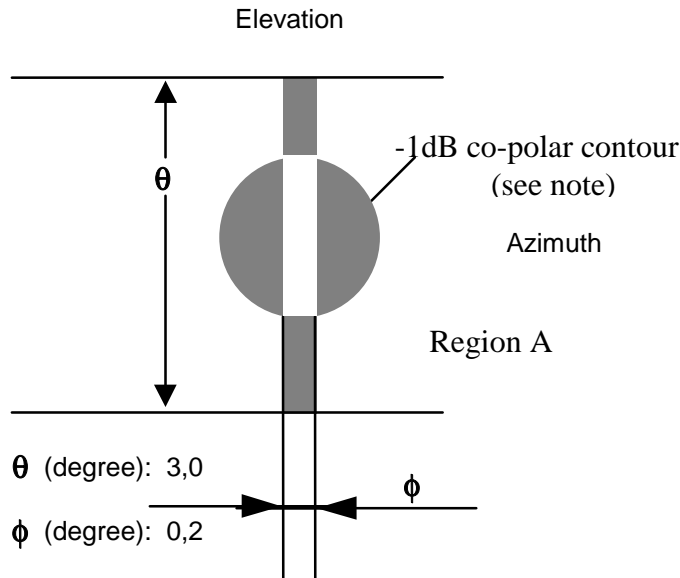

NOTE: For the dual band antennas -1 dB contour for highest frequency band shall be used.

Figure 9: Mask for XPD measurements around the main beam axis

6.3 Antenna gain

The gain of the antenna shall be expressed relative to an isotropic radiator (dBi). Antenna gain shall exceed the minimum value throughout its operational frequency range. There are two categories of minimum antenna gain covered by this ETS as follows:

Gain Category 1: 28 dBi;

Gain Category 2: 32 dBi.

Regulators will specify one gain category which is to be used for each co-ordination task.

7 Conformance tests

For antenna parameters, EN 301 126-1 [4] shall apply.

Annex A (informative): Additional information

A.1 Mechanical characteristics

A.1.1 Environmental characteristics

The antennas should be designed to operate within a temperature range of -45 °C to +45 °C with a relative humidity up to 100 % with salt mist, industrial atmosphere, UV-radiation etc.

The temperature range could be divided in two parts where at least one of the following ranges should be covered:

- 1) -33 °C to +40 °C;
- 2) -45 °C to +45 °C.

The antennas should be designed to meet wind survival ratings specified in table A.1:

Table A.1

Antenna type	Wind velocity m/s (km/h)	Ice load (density 7 kN/m ³)
Normal duty	55 (200)	25 mm radial ice
Heavy duty	70 (252)	25mm radial ice

A.1.2 Antenna stability

The antenna equipment should be stable under the most severe operational conditions at the site of intended application.

For installation on trellis or towers, the deviation of the antenna main beam axis should not be more than 0,3 times the -3 dB beam width under the conditions specified in table A.2:

Table A.2

Antenna type	Wind velocity m/s (km/h)	Ice load (density 7 kN/m ³)
Normal duty	30 (110)	25 mm radial ice
Heavy duty	45 (164)	25 mm radial ice

A.2 Antenna input connectors

When flanges are provided at the input port of the antenna they should be in accordance with IEC 60154.

For antennas which are integrated to the radio equipment proprietary connection designs may be utilized.

For antennas using coaxial input ports the connectors should conform to IEC 60169.

Other interconnection design should be agreed between the equipment supplier and purchaser in line with the overall system design requirements.

A.3 Return loss at the input ports

The minimum return loss should be agreed between the equipment supplier and purchaser in line with the overall system design requirements.

For guidance, antennas with a Voltage Standing Wave Ratio (VSWR) in a range of 1,06 to 1,2 are typical.

A.4 Inter-port isolation

The isolation between the input ports of a dual polarized antenna should be agreed between the equipment supplier and purchaser in line with the overall system design requirements.

For guidance the isolation between ports may be between 35 dB to 50 dB.

A.5 Antenna labelling

It is recommended that the antennas should be clearly identified with a weather-proof and permanent label showing the manufacturers name, antenna type, serial number and type approval reference number which identifies the country of origin.

Annex B (informative): Bibliography

- IEC 60050-712: "International Electrotechnical Vocabulary - Chapter 712: Antennas".
- IEEE Standard 145: "Definitions of terms in the field of antennas are provided".
- DIN 45.030; Part 1: "Definitions, antennas".
- DIN 45.030; Part 2: "Concepts, antennas".
- ITU-R Recommendation F.699-3 (REVISED): "Reference radiation patterns for line-of-sight radio-relay system antennas for use in coordination studies and interference assessment in the frequency range from 1 to about 40 GHz".
- CCIR Report 614-3 (1990): "Reference radiation patterns etc.".
- ANSI/IEEE Standard 149: "Test Procedures for Antennas".
- ANSI/EIA-195-C (1985): "Terrestrial microwave relay antennas".
- MIL-G-24.211: "Gaskets for waveguide flanges".

History

Document history			
February 1997	Public Enquiry	PE 9724:	1997-02-14 to 1997-06-13
March 1999	Vote	V 9922:	1999-03-30 to 1999-05-28
June 1999	First Edition		