



EUROPEAN
TELECOMMUNICATION
STANDARD

DRAFT
pr **ETS 300 822**

February 1997

Source: ETSI EP-DECT

Reference: DE/DECT-030039

ICS: 33.020

Key words: DECT, ISDN

**Digital Enhanced Cordless Telecommunications (DECT);
Integrated Services Digital Network (ISDN);
DECT/ISDN interworking for intermediate system configuration;
Interworking and profile specification**

ETSI

European Telecommunications Standards Institute

ETSI Secretariat

Postal address: F-06921 Sophia Antipolis CEDEX - FRANCE

Office address: 650 Route des Lucioles - Sophia Antipolis - Valbonne - FRANCE

X.400: c=fr, a=atlas, p=etsi, s=secretariat - **Internet:** secretariat@etsi.fr

Tel.: +33 4 92 94 42 00 - Fax: +33 4 93 65 47 16

Copyright Notification: No part may be reproduced except as authorized by written permission. The copyright and the foregoing restriction extend to reproduction in all media.

© European Telecommunications Standards Institute 1997. All rights reserved.

Contents

Foreword	9
Introduction.....	9
1 Scope	11
2 Normative references.....	11
3 Definitions and abbreviations	13
3.1 Definitions	13
3.2 Abbreviations	15
4 Interworking requirements.....	16
4.1 Reference configurations and interfaces.....	16
4.1.1 Reference configurations	16
4.1.2 ISDN interfaces	17
4.2 Service requirements.....	17
4.2.1 Bearer service requirements	17
4.2.2 Teleservice requirements.....	17
4.2.3 General aspects on error performance	18
4.2.4 Supplementary service requirements.....	18
5 Protocol architecture	18
5.1 General	18
6 Interworking procedures.....	20
6.1 Procedural overview	20
6.2 DECT signalling link management.....	20
6.2.1 General description	20
6.2.2 Activation from the ISDN network	20
6.2.3 Activation from the ISDN terminal	21
6.2.4 Release of the signalling link.....	22
6.3 U-plane and B-channel management.....	22
6.3.1 U-plane management.....	22
6.3.2 B-channel management.....	25
6.4 L2 address management	25
6.5 Outgoing call procedures.....	26
6.6 Incoming call procedures.....	28
6.6.1 Point to multipoint configuration	28
6.6.2 Point to point configuration.....	30
6.7 Release procedures.....	32
6.7.1 Release from the ISDN network.....	32
6.7.2 L2 disconnection from the ISDN network (point to point only)	33
6.7.3 Release from the ISDN terminal	34
6.7.4 L2 disconnection from the ISDN terminal.....	34
7 Physical layer procedures	35
7.1 General requirement.....	35
7.2 Minimum Normal Transmit Power (NTP).....	35
7.3 Radio receiver sensitivity	35
7.4 Z-field requirement.....	35
7.5 Sliding collision detection.....	35
7.6 Physical channel availability.....	36
7.7 Synchronization window.....	36
8 MAC layer procedures.....	36

8.1	MAC layer signalling procedures.....	36
8.1.1	Downlink broadcast	36
8.1.1.1	N_t message.....	36
8.1.1.2	Q_t - static system information	37
8.1.1.3	Q_t - FP capabilities.....	37
8.1.1.4	Q_t Extended FP capabilities.....	38
8.1.1.5	Q_t - SARI list contents.....	38
8.1.1.6	Paging broadcast: short page	39
8.1.1.7	Paging broadcast: zero page	40
8.1.2	Activation of the signalling connection.....	40
8.1.2.1	General requirement.....	40
8.1.2.2	Activation from the ISDN network	40
8.1.2.3	Activation from the ISDN terminal.....	42
8.1.2.4	MBn advanced connection control messages	43
8.1.2.5	Associated procedure (s).....	44
8.1.2.5.1	Timer T200 management.....	44
8.1.2.5.2	Counter N200 management.....	44
8.1.2.6	Exceptional case	45
8.1.2.6.1	Bearer setup fails or timer T200 expiry	45
8.1.3	Release of signalling link	46
8.1.3.1	MBn release message	48
8.1.4	Dynamic C-plane switching: MAC layer procedures.....	48
8.1.4.1	Dynamic switching C_F to C_S : only DIFS initiated.....	48
8.1.4.2	Dynamic switching C_S to C_F : DIPS initiated.....	51
8.1.4.3	Dynamic switching C_S to C_F : DIFS initiated	52
8.1.4.4	Dynamic switching C_S x to C_S y: only DIFS initiated	55
8.1.4.5	Associated procedures	57
8.1.4.5.1	Associated procedures: DIFS side.....	57
8.1.4.5.2	Associated procedures: DIPS side.....	57
8.2	MAC Layer U-plane procedures.....	57
8.2.1	U-plane connection setup procedure.....	57
8.2.1.1	MBn messages advanced connection control	59
8.2.2	U-plane connection release procedure.....	59
8.2.2.1	MBn release message	60
8.3	Signalling and U-plane connections: Timer T201	61
8.3.1	Timer T201	61
8.3.2	Timer T201 expiry.....	61
9	DLC layer procedures.....	62
9.1	DLC layer signalling procedures	62
9.1.1	Class B link establishment.....	62
9.1.2	Associated procedure(s).....	64
9.1.2.1	Timer <DL.02> management.....	64
9.1.2.2	Re-transmission counter management.....	64
9.1.2.3	Multiple frame operation variables	64
9.1.3	Class B acknowledged information transfer	65
9.1.3.1	Acknowledgement with an I_frame	65
9.1.3.2	Acknowledgement with a RR_frame.....	66
9.1.3.3	Acknowledgement with an RNR_frame	68
9.1.3.4	Acknowledgement with an REJ_frame	69
9.1.4	Segmentation of NWK layer message.....	69
9.1.5	Associated procedure(s).....	69
9.1.5.1	Timer <DL.04> management.....	69
9.1.5.2	Timer <DL.04> expiry.....	69
9.2	DLC Layer U-plane procedures.....	70
9.2.1	FU1 frame operation.....	70
9.2.2	LU7 data bearer service	71
9.2.3	LU8 service.....	71
9.2.3.1	Physical layer service.....	71
9.2.3.2	MAC layer service	71
9.2.3.3	DLC layer service.....	71
10	Network layer procedures.....	72

10.1	Network layer C-plane procedures	72
10.1.1	General overview.....	72
10.1.2	Establishment of the signalling channel	72
10.1.2.1	Indirect DIFS initiated link establishment.....	72
10.1.2.2	Direct DIPS initiated link establishment.....	74
10.1.3	Transmitting of D-channel data	75
10.2	Network Layer U-plane procedures	75
10.2.1	Establishment of DECT-U-planes and their switching to B-channels	75
10.2.1.1	Establishment of the DECT-U-planes.....	75
10.2.1.2	Switching of U-plane to B-channel.....	77
10.2.2	Release procedures	79
10.2.3	Switching of the B-channel.....	80
10.3	Mobility and security features.....	80
10.3.1	Mobility and security features: additional requirements.....	81
11	IWU procedures	81
11.1	Link association entity.....	81
11.1.1	General.....	81
11.1.2	Normal procedures.....	82
11.1.2.1	Transfer of broadcasted L3 messages.....	82
11.1.2.2	Transfer of L 3 messages on a point-to-point L 2 link	82
11.1.2.2.1	LA-establishment	82
11.1.2.2.2	LA data transfer	82
11.1.2.2.3	LA release.....	82
11.1.3	Exceptional handling and supervision	83
11.1.3.1	Rejection of ISDN-L2 establishment.....	83
11.1.3.2	Rejection of a transfer request at the C-plane-channel.....	83
11.1.3.3	CEI-problems.....	83
11.1.3.4	L2-command coding problems	84
11.1.4	Supervisory.....	84
11.1.4.1	Monitoring of ISDN-L2 links by the DIPS.....	84
11.1.5	LAE parameters	84
11.2	Layer 3 monitoring	84
11.3	State machine	85
11.3.1	General overview.....	85
11.3.2	IWU call states	85
11.3.3	State transitions.....	85
11.3.4	Parameters.....	86
11.4	Actions upon missing DECT resources	87
11.4.1	General.....	87
11.4.2	Actions of the DIFS	87
11.4.2.1	The C-plane-channel cannot be established	87
11.4.2.1.1	Point-to-point configuration	87
11.4.2.1.2	Point-to-multipoint configuration	87
11.4.2.2	The C-plane-channel is lost.....	87
11.4.2.3	An U-plane-channel cannot be established	87
11.4.2.3.1	Point-to-point configuration.....	87
11.4.2.3.2	Point-to-multipoint configuration	87
11.4.2.4	An U-plane-channel is lost.....	88
11.4.2.4.1	Point-to-point configuration and outgoing call in a point-to-multipoint configuration	88
11.4.2.4.2	Point-to-multipoint configuration, incoming call	88
11.4.3	Actions of the DIPS	88
11.4.3.1	The C-plane-channel cannot be established or is lost.....	88
11.4.3.2	An U-plane-channel cannot be established	88
11.4.3.3	An U-plane-channel is lost.....	88
11.5	Other interworking functions	88
11.5.1	Call hold.....	88
11.5.2	Fall back procedure.....	89
11.5.3	Terminal portability	89

12	Dynamic switching procedures	89
12.1	Dynamic switching procedures between DECT signalling channels.....	89
12.1.1	First establishment of signalling bearer (C _F)	91
12.1.2	General description of the C-plane switching procedure	92
12.1.3	Switching from C _F to C _S channel, only DIFS initiated.....	92
12.1.4	Switching between C _S and C _S channel, only DIFS initiated	94
12.1.5	Switching from C _S to C _F , DIFS initiated.....	95
12.1.6	Switching from C _S to C _F , DIPS initiated.....	96
12.1.7	LCN - management	96
12.1.8	Conditions for dynamic signalling channel switching	97
12.2	Dynamic switching procedures between DECT U-planes.....	97
12.2.1	Dynamic switching procedures from LU1 to LU7	97
12.2.2	Dynamic switching procedures from LU7 to LU1	100
	12.2.2.1 Procedure description	101
	12.2.2.1.1 Connection handover procedure	101
	12.2.2.1.2 Release of the second part of the double slot procedure.....	102
	12.2.2.1.3 Associated procedures.....	105
12.2.3	Dynamic switching procedures from LU1 to LU8	106
12.2.4	Dynamic switching procedures from U-plane LU8 to LU1.....	107
	12.2.4.1 Dynamic switching procedures from LU7 to LU8.....	108
	12.2.4.1.1 Procedure description	108
	12.2.4.2 Dynamic switching procedures from LU8 to LU7.....	109
	12.2.4.2.1 Procedure description	110
13	Maintenance	112
13.1	Exchange of operation and maintenance information.....	112
14	Coding	112
14.1	IWU-INFORmation for DECT/ISDN intermediate system	112
14.2	IWU to IWU for DECT/ISDN intermediate system.....	112
	14.2.1 C-plane specific	113
	14.2.1.1 Coding for "release required"	113
	14.2.1.2 Coding for "other" L2 commands	114
	14.2.2 U-plane specific	114
	14.2.3 Operation and maintenance specific	115
Annex A (informative):	Modifications to ETS 300 175.....	116
A.1	Modifications to the MAC layer (ETS 300 175-3)	116
A.1.1	Specific for U-plane switching procedures	116
A.1.2	Specific for C-plane switching procedure.....	116
A.2	Modifications to the DLC layer (ETS 300 175-4)	118
A.2.1	General.....	118
	A.2.1.1 LU7 64 kbit/s data bearer service	118
	A.2.1.2 LU8 bearer service	118
A.3	Modifications to the NWK layer (ETS 300 175-5).....	118
A.3.1	General.....	118
A.3.2	Specific for U-plane switching procedures	119
A.3.3	Amendment to basic service IE.....	120
Annex B (informative):	Handover and collision scenarios	121
B.1	C-plane switching procedures	121
B.1.1	C-plane switching: handover collision scenarios.....	121
	B.1.1.1 C _F to C _S switching procedure: concurrent handover scenario	121
	B.1.1.2 C _S to C _F switching procedure: concurrent handover scenario	122
	B.1.1.3 Dynamic switching C _F to C _S bearer handover collision	124
	B.1.1.4 Conclusions	124
B.1.2	C-plane switching: ciphering procedure collision scenarios.....	125
	B.1.2.1 Dynamic switching C _F to C _S ciphering procedure collision.....	125

B.2	LU service switch	126
B.2.1	General	126
B.2.2	Switching from LU1 to LU7: bearer handover collision	126
Annex C (informative):	Examples for segmentation of ISDN messages.....	127
History.....		128

Blank page

Foreword

This draft European Telecommunication Standard (ETS) has been produced by the Digital Enhanced Cordless Telecommunications (DECT) Project of the European Telecommunications Standards Institute (ETSI), and is now submitted for the Public Enquiry phase of the ETSI standards approval procedure.

Proposed transposition dates	
Date of latest announcement of this ETS (doa):	3 months after ETSI publication
Date of latest publication of new National Standard or endorsement of this ETS (dop/e):	6 months after doa
Date of withdrawal of any conflicting National Standard (dow):	6 months after doa

Introduction

For interworking between an Integrated Services Digital Network (ISDN) and a DECT system, two profiles have been defined. The first profile is the DECT/ISDN profile for end system configuration. The second profile is the DECT/ISDN profile for intermediate system configuration. The first profile is also called the "ISDN Access Profile (IAP)". The second profile is also called the "Intermediate ISDN access Profile (IIP)".

The IAP applies when a Fixed Part (FP) and a Portable Part (PP) together constitute an ISDN terminal. The ISDN applications and any supplementary services are located in the PP (no Interworking Unit (IWU) in the PP). The FP maps the received layer 3 messages at the ISDN interface to the DECT layer 3 messages and vice-versa.

The IIP applies when a FP and a PP together constitute a gateway between an ISDN network and an ISDN terminal. The FP and the PP have an IWU, which maps the messages between the ISDN interface and the DECT air interface.

This ETS specifies the DECT/ISDN profile for intermediate system configuration only. For details on DECT/ISDN profile for end system configuration, see ETS 300 434 [29].

This ETS specifies how ISDN services are provided over the DECT air interface.

One of the main objectives is to describe how the ISDN services are mapped across the DECT air interface in a formal way, so that equipment interoperability of different manufacturers' equipment can be achieved.

Blank page

1 Scope

This European Telecommunication Standard (ETS) specifies how Integrated Services Digital Network (ISDN) services can be provided over Digital Enhanced Cordless Telecommunications (DECT). It is based on DECT Common Interface (CI) specification ETS 300 175, parts 1 to 8 [1] to [8], to enable ISDN terminals to have cordless access to an ISDN infrastructure. Both public ISDN and private ISDN are within the scope of this ETS.

The user has transparent access to the ISDN services and functions. In respect to bearer services, the following are supported: speech, 3,1 kHz audio, unrestricted 64 kbit/s data, packet data and user signalling bearer service.

The DECT intermediate system configuration differs from the DECT end system configuration as follows. The intermediate system is used to enable ISDN terminals to have cordless access to an ISDN infrastructure via a DECT air interface. The end system is used where the DECT Fixed Part (FP) and the DECT Portable Part (PP) together form an end system with the behaviour of an ISDN Terminal Equipment (TE).

2 Normative references

This ETS incorporates by dated and undated reference, provisions from other publications. These references are cited at the appropriate places in the text and the publications are listed hereafter. For dated references, subsequent amendments to or revisions of any of these publications apply to this ETS only when incorporated in it by amendment or revision. For undated references the latest edition of the publication referred to applies.

- [1] ETS 300 175-1: "Radio Equipment and Systems (RES); Digital European Cordless Telecommunications (DECT); Common Interface (CI); Part 1: Overview".
- [2] ETS 300 175-2: "Radio Equipment and Systems (RES); Digital European Cordless Telecommunications (DECT); Common Interface (CI); Part 2: Physical Layer".
- [3] ETS 300 175-3: "Radio Equipment and Systems (RES); Digital European Cordless Telecommunications (DECT); Common Interface (CI); Part 3: Medium Access Control (MAC) layer".
- [4] ETS 300 175-4: "Radio Equipment and Systems (RES); Digital European Cordless Telecommunications (DECT); Common Interface (CI); Part 4: Data Link Control (DLC) layer".
- [5] ETS 300 175-5: "Radio Equipment and Systems (RES); Digital European Cordless Telecommunications (DECT); Common Interface (CI); Part 5: Network (NWK) layer".
- [6] ETS 300 175-6: "Radio Equipment and Systems (RES); Digital European Cordless Telecommunications (DECT); Common Interface (CI); Part 6: Identities and addressing".
- [7] ETS 300 175-7: "Radio Equipment and Systems (RES); Digital European Cordless Telecommunications (DECT); Common Interface (CI); Part 7: Security features".
- [8] ETS 300 175-8: "Radio Equipment and Systems (RES); Digital European Cordless Telecommunications (DECT); Common Interface (CI); Part 8: Speech coding and transmission".
- [9] ETS 300 108: "Integrated Services Digital Network (ISDN); Circuit-mode 64 kbit/s unrestricted 8 kHz structured bearer service category; Service description".

- [10] ETS 300 109: "Integrated Services Digital Network (ISDN); Circuit-mode 64 kbit/s structured bearer service category usable for speech information transfer; Service description".
- [11] ETS 300 110: "Integrated Services Digital Network (ISDN); Circuit-mode 64 kbit/s 8 kHz structured bearer service category usable for 3,1 kHz audio information transfer; Service description".
- [12] ETS 300 475-1: "Private Telecommunication Network (PTN); Reference configuration; Part 1: Reference configuration for PTN eXchanges (PTNX) [ISO/IEC 11579-1 (1994), modified]".
- [13] ETS 300 012: "Integrated Services Digital Network (ISDN); Basic user-network interface; Layer 1 specification and test principles".
- [14] ETS 300 403-1: "Integrated Services Digital Network (ISDN); Digital Subscriber Signalling System No. one (DSS1) protocol; Signalling network layer for circuit-mode basic call control; Part 1: Protocol specification [ITU-T Recommendation Q.931 (1993), modified]".
- [15] ETS 300 444: "Radio Equipment and Systems (RES); Digital European Cordless Telecommunications (DECT); Generic Access Profile (GAP)".
- [16] ETS 300 192: "Private Telecommunications Network (PTN); Signalling protocol at the S-reference point; Circuit mode basic services".
- [17] ETS 300 171: "Private Telecommunication Network (PTN); Specification, functional models and information flows; Control aspects of circuit mode basic services".
- [18] CCITT Recommendation I.232.1 (1988): "Virtual call and permanent virtual circuit bearer service category".
- [19] ETS 300 049: "Integrated Services Digital Network (ISDN); ISDN Packet Mode Bearer Service (PMBS); ISDN Virtual Call (VC) and Permanent Virtual Circuit (PVC) bearer services provided by the D-channel of the user access - basic and primary rate".
- [20] ETS 300 048: "Integrated Services Digital Network (ISDN); ISDN Packet Mode Bearer Service (PMBS); ISDN Virtual Call (VC) and Permanent Virtual Circuit (PVC) bearer services provided by the B-channel of the user access - basic and primary rate".
- [21] ETS 300 196-1: "Integrated Services Digital Network (ISDN); Generic functional protocol for the support of supplementary services; Digital Subscriber Signalling System No. one (DSS1) protocol; Part 1: Protocol specification".
- [22] ETS 300 125: "Integrated Services Digital Network (ISDN); User-network interface data link layer specification; Application of CCITT Recommendations Q.920/I.440 and Q.921/I.441".
- [23] CCITT Recommendation G.711 (1988): "Pulse code modulation (PCM) of voice frequencies".
- [24] CCITT Recommendation G.726 (1991): "40, 32, 24, 16 kbit/s adaptive differential pulse code modulation (ADPCM)".
- [25] ECMA TR/44 (1989): "An architectural framework for private networks".
- [26] ITU-T Recommendation Q.931 (1993): "ISDN user-network interface layer 3 specification for basic call control".

- [27] CCITT Recommendation G.821 (1988): "Error performance of an international digital connection forming part of an integrated services digital network".
- [28] ITU-T Recommendation I.411: (1993): "ISDN user-network interfaces - Reference configurations".
- [29] ETS 300 434: "Radio Equipment and Systems (RES); Digital Enhanced Cordless Telecommunications (DECT) and Integrated Services Digital Network (ISDN) interworking for end system configuration".

3 Definitions and abbreviations

3.1 Definitions

For the purposes of this ETS, the following definitions apply:

bearer service: A type of telecommunication service that provides a defined capability for the transmission of signals between user-network interfaces.

NOTE 1: The DECT user-network interface corresponds to the top of the network layer (layer 3).

broadcast: A simplex point-to-multipoint mode of transmission.

C-plane: The control plane of the DECT protocol stacks, which contains all of the internal DECT protocol control, but may also include some external user information.

NOTE 2: The C-plane stack always contains protocol entities up to and including the network layer.

call: All of the NWK layer processes involved in one network layer peer-to-peer association.

NOTE 3: Call may sometimes be used to refer to processes of all layers, since lower layer processes are implicitly required.

DECT intermediate fixed system: A logical grouping that contains all the functions between the DECT DI reference point and the reference point on the fixed side of the DECT air interface.

NOTE 4: The DECT Intermediate Fixed System (DIFS) = FT + (local network up to the fixed side ISDN reference point (including fixed side IWU));

DECT intermediate portable system: A logical grouping that contains all the functions between the DECT DI reference point and the ISDN S reference point on the portable side of the DECT air interface.

NOTE 5: The DECT Intermediate Portable System (DIPS) = PT + (PA (Portable Application) up to the portable side ISDN S reference point (including portable side IWU))

DECT network: A network that uses the DECT air interface to interconnect a local network to one or more portable applications. The logical boundaries of the DECT network are defined to be at the top of the DECT network layer.

NOTE 6: A DECT Network (DNW) is a logical grouping that contains one or more fixed radio terminations plus their associated portable radio termination. The boundaries of the DECT network are not physical boundaries.

end system: A logical grouping that contains application processes and supports telecommunication services.

NOTE 7: From the OSI point of view, end systems are considered as sources and sinks of information.

equipment interoperability: The capability of fixed and PPs supplied by different manufacturers to interoperate in a multivendor environment.

Fixed Part (DECT Fixed Part) (FP): A physical grouping that contains all of the elements in the DECT network between the local network and the DECT air interface.

NOTE 8: A DECT FP contains the logical elements of at least one fixed radio termination, plus additional implementation specific elements.

Fixed radio Termination (FT): A logical group of functions that contains all of the DECT processes and procedures on the fixed side of the DECT air interface.

NOTE 9: A fixed radio termination only includes elements that are defined in the DECT CI standard. This includes radio transmission elements together with a selection of layer 2 and layer 3 elements.

Generic Access Profile (GAP): The profile applicable to all DECT Portable radio Terminations (PTs) and Fixed radio Terminations (FTs) which are subject to CTR 10 (i.e. 3,1 kHz telephony teleservice). The GAP ensures air interface interoperability of DECT equipment capable of 3,1 kHz telephony applications, in such a way that any DECT PT conforming to the GAP is interoperable with any DECT FT conforming to the GAP.

incoming call: A call received at a PP.

Interworking Unit (IWU): A unit that is used to interconnect subnetworks.

NOTE 10: The IWU will contain the interworking functions necessary to support the required subnetwork interworking.

ISDN access profile: A defined part of the DECT/ISDN interworking standard that ensures interoperability between FPs and PPs for the access of ISDN services.

local network: A telecommunication network capable of offering local telecommunication services.

NOTE 11: The term does not include legal or regulatory aspects, nor does it indicate if the network is a public network or a private network.

MAC Connection (CONNECTION): An association between one source MAC Multi-Bearer Control (MBC) entity and one destination MAC MBC entity. This provides a set of related MAC services (a set of logical channels), and it can involve one or more underlying MAC bearers.

outgoing call: A call originating from a PP.

paging: The process of broadcasting a message from a DECT FP to one or more DECT PPs.

NOTE 12: Different types of paging message are possible. For example, the {LCE_REQUEST-PAGE} message orders the recipient to respond with a call setup attempt.

portable application: A logical grouping that contains all the elements that lie beyond the DECT network boundary on the portable side.

NOTE 13: The functions contained in the portable application may be physically distributed, but any such distribution is invisible to the DECT network.

Portable Part (DECT Portable Part) (PP): A physical grouping that contains all elements between the user and the DECT air interface. PP is a generic term that may describe one or several physical pieces.

NOTE 14: A DECT PP is logically divided into one PT plus one or more portable applications.

Portable radio Termination (PT): A logical group of functions that contains all of the DECT processes and procedures on the portable side of the DECT air interface.

NOTE 15: A portable radio termination only includes elements that are defined in the DECT CI standard. This includes radio transmission elements (layer 1) together with a selection of layer 2 and layer 3 elements.

Radio Fixed Part (RFP): One physical sub-group of a FP that contains all the radio end points (one or more) that are connected to a single system of antennas.

segment: One of the pieces of data that is produced by the process of segmentation.

NOTE 16: In general, one segment only represents a portion of a complete message.

segmentation: The process of partitioning one service data unit from a higher layer into more than one protocol data unit. The reverse process is assembly.

supplementary service: A service that modifies or supplements a basic telecommunication service.

teleservice: A type of telecommunication service that provides the complete capability, including terminal equipment functions, for communication between users, according to protocols that are established by agreement.

U-plane: The user plane of the DECT protocol stacks. This plane contains most of the end-to-end (external) user information and user control.

NOTE 17: The U-plane protocols do not include any internal DECT protocol control, and it may be null at the network layer and at the DLC layers for some services.

3.2 Abbreviations

For the purposes of this ETS, the following abbreviations apply:

BA	Basic Access
C	C reference point
C/L	Connectionless mode
C/O	Connection Oriented mode
CC	Call Control
CI	Common Interface
CLMS	Connectionless Message Service
COMS	Connection Oriented Message Service
CRSS	Call Related Supplementary Services
DECT	Digital Enhanced Cordless Telecommunications
DI	DECT reference point for Intermediate system
DIFS	DECT Intermediate Fixed System
DIPS	DECT Intermediate Portable System
DLC	Data Link Control
DNW	DECT Network
DTMF	Dual Tone Multi-Frequency
ES	End System
FP	Fixed Part
FT	Fixed radio Termination
GAP	Generic Access Profile
IE	Information Element
ISDN	Integrated Services Digital Network
IWU	Interworking Unit
LA	Link Association
LAE	Link Association Entity
LCE	Link Control Entity
LLME	Lower Layer Management Entity
LNW	Local Network
LSB	Least Significant bit
MAC	Medium Access Control
MM	Mobility Management
MSB	Most Significant bit
NT1	Network Termination 1
NT2	Network Termination 2
NWK	Network
P	P reference point
PA	Portable Application

PABX	Private Automatic Branch Exchange
PBX	Private Branch Exchange
PP	Portable Part
PRA	Primary Rate Access
PSTN	Public Switched Telephone Network
PT	Portable radio Termination
R	R reference point
REP	Radio End Point
RFP	Radio Fixed Part
RFPI	Radio Fixed Part Identity
S	S reference point
S/T	S/T reference point
SAP	Service Access Point
SDD	System Description Document
SS	Supplementary Services
T	T reference point
TA	Terminal Adapter
TE1	ISDN terminal
TEI	Terminal Endpoint Identifier
TI	Transaction Identifier
vBA	virtual Basic Access

4 Interworking requirements

4.1 Reference configurations and interfaces

4.1.1 Reference configurations

Reference configurations describe the functional groupings of DECT and ISDN and their relationships via reference points. In general, reference points may or may not correspond to a physical interface. The functional groupings and reference points are described in ITU-T Recommendation I.411 [28] for public ISDN and in ETS 300 475-1 [12] for private ISDN.

The DECT intermediate system reference configurations are used where the DECT Intermediate Fixed System (DIFS) and DECT Intermediate Portable System (DIPS) together form an intermediate system to connect an ISDN terminal to an ISDN network.

Figure 1 shows the intermediate system reference configurations.

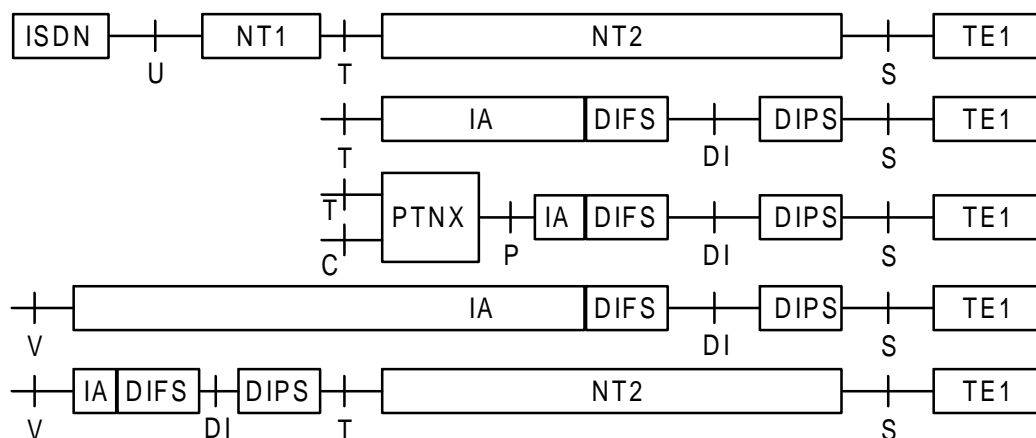

DIFS: DECT Intermediate Fixed System
 DIPS: DECT Intermediate Portable System
 IA: Interface Adapter

Figure 1: Intermediate system reference configurations

4.1.2 ISDN interfaces

The version of the public ISDN basic and primary rate access interface specification used for the Basic Access (BA) and Primary Rate Access (PRA) interworking is given in ETS 300 403-1 [14] and ITU-T Recommendation Q.931 [26]. The private ISDN basic and primary rate access interface specification ETS 300 192 [16] is very similar to the public ISDN specification, and is not considered further.

In order to make the complexity of different ISDN interfaces invisible to the DECT air interface, an "Interface Adapter" is introduced. This maps the different ISDN interfaces on to a virtual Basic Access (vBA) interface. This standard specifies the interworking between the vBA interface and the DECT air interface. Interworking between the actual ISDN interface and the vBA interface is inside ISDN and therefore not specified in this standard. All further references to DECT intermediate fixed system for the intermediate system in this standard refer to the Basic Rate DECT intermediate fixed system as shown in figure 2.

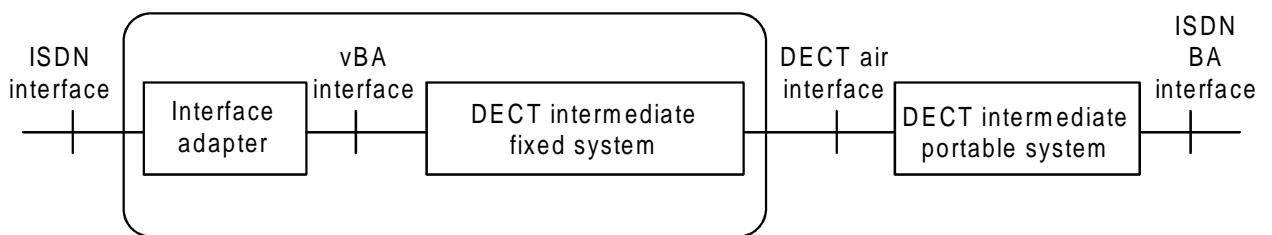

NOTE 1: The interface adapter can provide more than one virtual basic rate interface.

NOTE 2: There is no requirement that the virtual basic rate interface has to be implemented physically.

NOTE 3: In the case that the ISDN interface is a So interface the interface adapter has no functionality.

Figure 2: DECT intermediate fixed system interfaces for intermediate system

This ETS only considers the case of a basic rate interface at the portable side.

4.2 Service requirements

4.2.1 Bearer service requirements

The support of the following bearer services is specified for the intermediate system reference configuration:

- circuit-mode speech (ETS 300 109 [10] and ETS 300 171 [17]);
- circuit-mode 3,1 kHz audio (ETS 300 110 [11] and ETS 300 171 [17]*);
- circuit-mode 64 kbit/s unrestricted (digital information) (ETS 300 108 [9] and ETS 300 171 [17]*);
- packet-mode (X-31 case B) D-channel (packet data) (CCITT Recommendation I.232.1 [18] and ETS 300 049 [19]);
- packet-mode (X-31 case B) B-channel (packet data) (CCITT Recommendation I.232.1 [18] and ETS 300 048 [20]);
- user signalling bearer service.

The bearer services marked with * are the minimum set covered by the 1989 MoU for European Network Operators.

4.2.2 Teleservice requirements

The teleservice itself is not of interest for the DECT intermediate system. The only (indirect) effect is via the bearer service that is used by a specific teleservice.

4.2.3 General aspects on error performance

The purpose of the services is to allow the users to exchange user information with service specific characteristics. Therefore the general requirement exists that this information needs to be conveyed by such means that, if at all, only a very small portion can be tolerated to be corrupted within the network. The profile of corruption needs to be predictable so that means can be provided outside the network for an efficient enhancement of the given error performance if necessary application dependent.

In this ETS, the error performance aspects are considered along with the service specific transmission methods applied. Here these aspects are preceded by the more general ISDN network point of view which can be considered to be the framing guideline for the services so far defined and for a wide range of applications not defined in ISDN and not known to the DECT/ISDN environment but relying on ISDN characteristics.

CCITT Recommendation G.821 [27] gives such objectives for quality and availability targets in terms of error performance parameters inside the network between the terminating T-ref. points, see table 1 in CCITT Recommendation G.821 [27]:

- degraded minutes: < 10 % of one-minute intervals have a BER worse than 10^{-6} .
- severely errored seconds: < 0,2 % of one-second intervals have a BER worse than 10^{-3} .
- errored seconds: < 8 % of one-second intervals have any error (equivalent to 92 % error free seconds).

NOTE: The achievable BER depends on the radio propagation conditions. The LU7 service is intended to improve the BER of the U-plane at the air interface towards the above values.

4.2.4 Supplementary service requirements

The support of most ISDN supplementary services does not require interworking functions in the DECT system. Some services (e.g. Call Hold, Terminal Portability) however require support by U-plane and B-channel management functions.

5 Protocol architecture

5.1 General

Protocol architecture models are used to describe the protocol interactions at control plane (C-plane) and user-plane (U-plane) of the DIFS and DIPS. The concept of the protocol architecture model is based on ECMA TR/44 [25].

NOTE 1: The IWU will contain the interworking functions necessary to support the required subnetwork interworking.

NOTE 2: The IWU's, in the context of DECT, interconnect the FT at the fixed side, and the PT at the portable side to the attached subnetwork.

The protocol architecture model for the intermediate system is based on the termination of the ISDN protocol layers 1 and 2 in the DECT Intermediate Fixed System and DECT Intermediate Portable System.

The DECT intermediate system relays the ISDN layer 3 messages in the DECT control plane using the <<IWU-TO-IWU>> Information Element (IE) and the {IWU-INFO} message. The fast signalling channel (C_F) or slow signalling channel (C_S) shall be used for carrying the signalling information depending on the actual signalling requirements.

The ISDN layer 2 link as well as the layer 1 are terminated at the DECT Intermediate Fixed System. A separate layer 2 link and layer 1 are used in the DECT Intermediate Portable System. The Terminal Endpoint Identifier (TEI) assigned by the DIPS to the ISDN terminal (TE1) shall be reported to the DIFS which shall contain the mapping table between the TEIs assigned by the DIPS and the ISDN network.

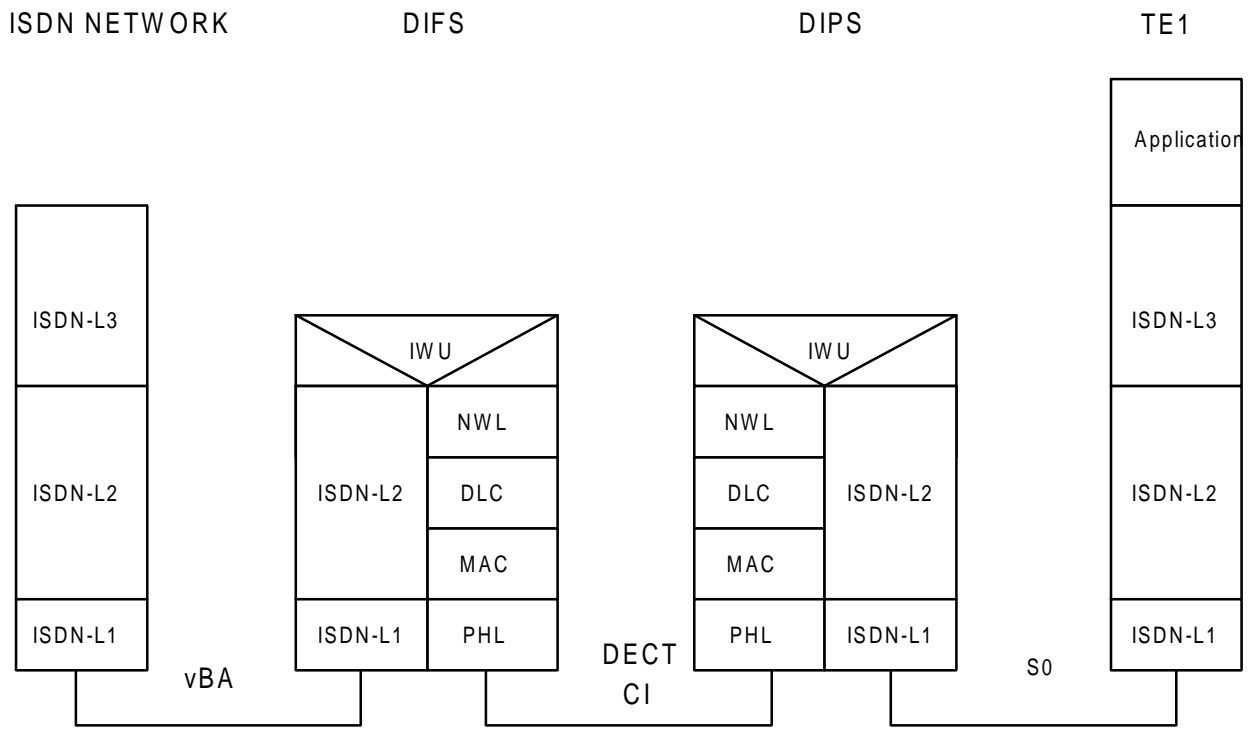

- ISDN L3: ETS 300 403-1 [14] and ITU-T Recommendation Q.931 [26]
- ISDN L2: ETS 300 125 [22]
- ISDN L1: ETS 300 012 [13]
- NWL: ETS 300 175-5 [5]
- DLC: ETS 300 175-4 [4]
- MAC: ETS 300 175-3 [3]
- PHL: ETS 300 175-2 [2]

Figure 3: Intermediate system C-plane model

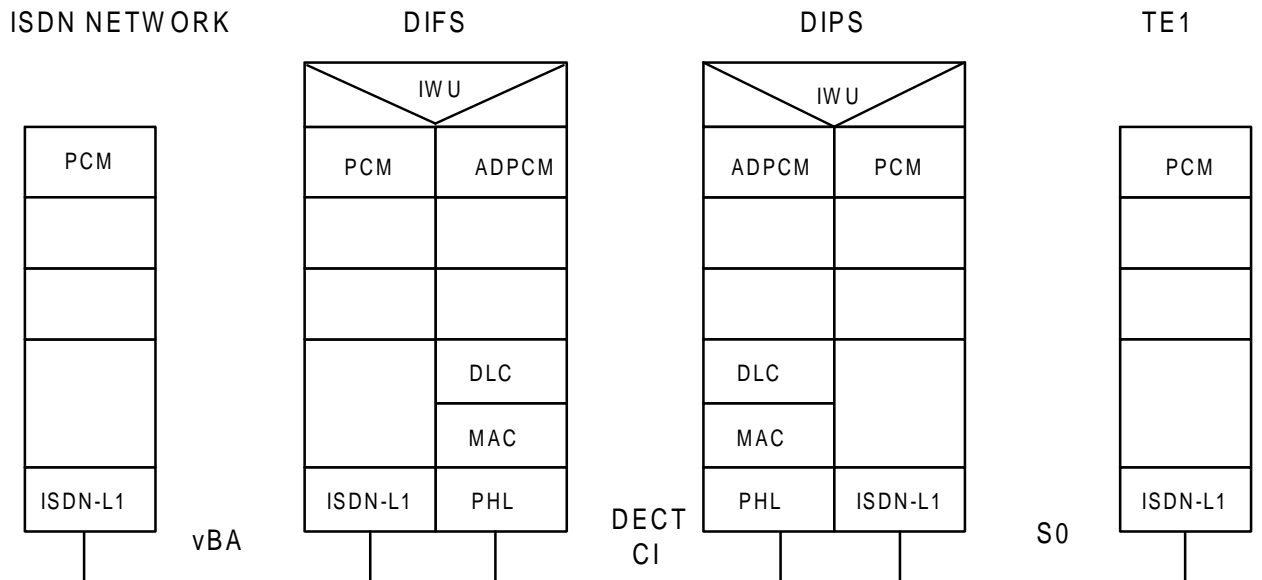

- PCM: CCITT Recommendation G.711 [23]
- ADPCM: CCITT Recommendation G.726 [24]
- ISDN L1: ETS 300 012 [13]
- DLC: ETS 300 175-4 [4]
- MAC: ETS 300 175-3 [3]
- PHL: ETS 300 175-2 [2]

Figure 4: Intermediate system U-plane model example - basic speech

6 Interworking procedures

This clause defines the interworking procedures in the IWU relating to the associated DECT and ISDN procedures.

6.1 Procedural overview

This subclause gives an overview of principles how the DECT system shall support ISDN functionality. The mapping principles are illustrated by some typical examples for the support of ISDN circuit switched calls. It should however be noted that these examples are not exhaustive. Further details for the mapping shall therefore be derived from the study of ISDN base standards in particular ETS 300 125 [22] (ISDN L2) and ITU-T Recommendation Q.931 [26] together with ETS 300 403-1 [14] and ETS 300 196-1 [21] (ISDN L3).

This procedural overview contains six parts.

The first part describes the mapping between the signalling ISDN D channel and the DECT DLC Class B link in case of activation from the ISDN network or from the ISDN terminal.

The second part describes the mapping of the ISDN B channels with the U-plane connections, and how the U-plane connections are created, configured and connected relatively to the associated signalling.

The third part describes the ISDN L2 address management for both the DIFS and the DIPS.

The fourth part describes the exchanges in case of outgoing call from the ISDN terminal.

The fifth part describes the exchanges in case of incoming call from the ISDN network.

The sixth part describes the release call procedures for both the DIFS and the DIPS.

6.2 DECT signalling link management

6.2.1 General description

While there is neither ISDN call in progress, nor ISDN layer 2 signalling ongoing, nor ISDN layer 3 signalling ongoing, only the downlink broadcast service exists in the direction DIFS to DIPS.

If an ISDN activation is detected at either the ISDN network side or the ISDN terminal side, then the following procedure shall be initiated. The detecting side of the activation (DIFS or DIPS) shall first determine if an existing DECT signalling link is already present. If no DECT signalling link exists, a DLC Class B link using full slot MAC C_F channel shall be established by the DIPS. Both sides shall determine if it is necessary to switch the DECT signalling link. In that case, the relevant procedure for switching the DECT signalling link shall be performed, otherwise the existing DECT signalling link shall be used.

When the last ISDN layer 2 connection has been released and a unnumbered information transfer is not pending, the DIFS shall initiate the procedure to release the existing DECT signalling link.

6.2.2 Activation from the ISDN network

If no DECT signalling link exists, on receipt of a broadcasted Layer 3 message or the detection of a L2 establishment from the ISDN network, the DIFS shall use fast or normal paging by sending an {LCE-REQUEST-PAGE} layer 3 message in short page format. On reception of this {LCE-REQUEST-PAGE} message the DIPS shall set up an advanced MAC connection. Afterwards the DIPS shall set up a DLC link using Class B acknowledged information transfer including the {LCE-PAGE-RESPONSE} message.

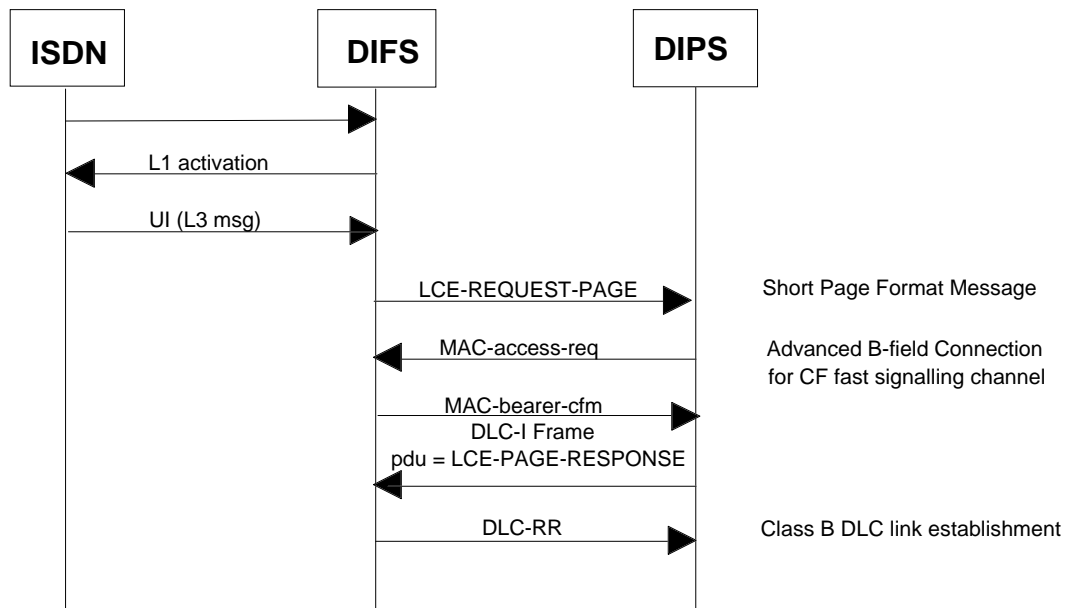

The Layer 3 {LCE-PAGE-RESPONSE} message shall be contained in the DLC establishment I Frame.

Figure 5: Setting up the signalling link for first activation from ISDN network upon a broadcasted L3 message

If a Class B DLC link exists with the DIPS, on receipt of layer 3 message from the ISDN network, the DIFS shall use this previously established link.

Subsequently the established signalling link shall be used to carry any DECT layer 3 signalling and any ISDN signalling associated with the new activation.

The ISDN signalling shall be transported inside an <<IWU-TO-IWU>> IE in a {IWU-INFO} message.

6.2.3 Activation from the ISDN terminal

If no DECT signalling link exists, on receipt of the first layer 2 activation from the TE1, the DIPS shall directly set up an advanced MAC connection and a DLC link using Class B acknowledged information transfer.

In case of failure of the MAC bearer set up procedure or failure of the Class B DLC link establishment procedure, the DIPS IWU shall disconnect the ISDN layer 2 link by using the relevant ISDN procedure.

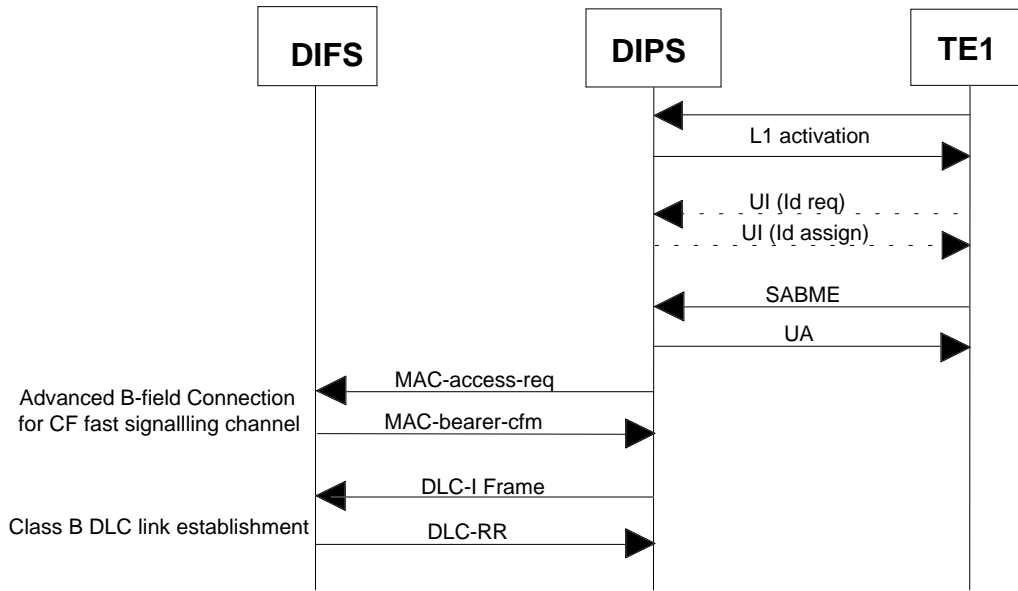

Figure 6: Setting up the signalling link for first call

If a Class B DLC layer 2 link exists with the DIFS, on receipt of activation from the ISDN terminal, the DIPS shall use this previously established link.

Subsequently the established signalling link shall be used to carry any DECT layer 3 signalling and any ISDN signalling associated to the new activation.

The ISDN signalling shall be transported inside an <<IWU-TO-IWU>> IE in an {IWU-INFO} message.

6.2.4 Release of the signalling link

When the last ISDN layer 2 connection has been released and no unnumbered information is pending, then the DIFS or DIPS shall release the associated DECT Class B DLC signalling link.

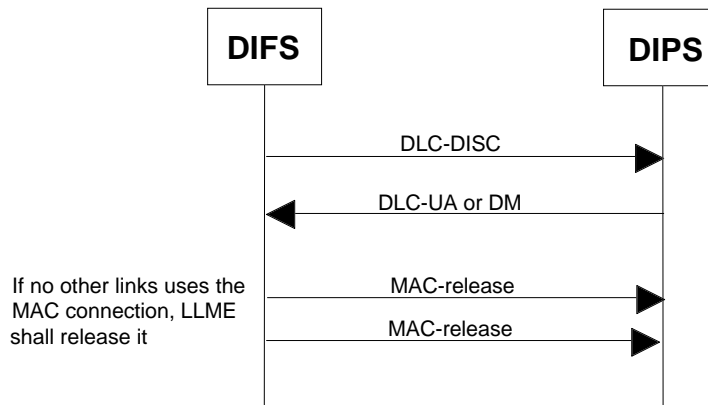

Figure 7: Example of release of the signalling link from the DIFS

6.3 U-plane and B-channel management

6.3.1 U-plane management

If a U-plane service is required, then an additional MAC connection shall be set up. According to the requested service either an unprotected minimum delay full slot MAC connection with the transparent LU1 DLC service or an unprotected normal delay double slot MAC connection together with the protected LU7 DLC service shall be used.

The following combinations are possible:

Table 1: ISDN D-channel and B-channel into DECT MAC slot mapping

D Channel	B channels	Comment
-	-	Stand by
1 full slot	-	Signalling only
≤ 1 full slot	1 full slot	1D + 1B (32)
≤ 1 full slot	1 double slot	1D + 1B (64)
≤ 1 full slot	2 full slots	1D + 2B (32)
≤ 1 full slot	1 full slot + 1 double slot	1D + 2B (32,64)
≤ 1 full slot	2 double slots	1D + 2B (64)
NOTE: The D channel can be conveyed on C _S signalling and therefore in one of the slots used for B channels. For some period, the full slot for D channel using C _F signalling can reappear.		

Table 2: Mapping of ISDN bearer services/transfer capabilities to DECT services

ISDN	DECT U-plane service	
3,1 kHz speech	LU1	ADPCM, 32 kbit/s
3,1 kHz audio	LU1	ADPCM, 32 kbit/s
unrestricted digital information circuit mode	LU7	
unrestricted digital information with T/A circuit mode	LU7	
Packet mode case B access via B-channel	LU7	
Packet mode case B access via D-channel		No U-plane service required
User signalling bearer service		No U-plane service required
NOTE: This table identifies the initial mapping at the time of connection setup. Depending on call scenarios or interpretation of inband information the ISDN service can also be supported by alternative DECT U-plane services as follows:		
-	3,1 kHz speech:	LU8
-	3,1 kHz audio:	LU7, LU8

The ISDN layer 3 monitoring is done in the DIFS. As a consequence the establishment and release of the B channels and DECT U-plane is controlled by the DIFS.

The DIFS, upon reception of an ISDN {SETUP} message (as described in subclauses 6.5 and 6.6) shall analyse the <<BEARER-CAPABILITY>> IE to determine the required attributes of the associated U-plane (if needed).

If the DIFS detects the need of a U-plane, then it shall request a new MAC connection to the DIPS.

For requesting the new MAC connection to the DIPS, the DIFS shall use a DECT {CC-SETUP} message indicating their relevant attributes.

In the used DECT {CC-SETUP} message the requested "connection-attributes" like MAC-service and DLC-service as well as the "connection-identity" (logical connection number) shall be indicated.

If the DIPS is unable to establish the requested connection it shall answer with a negative acknowledgement {CC-RELEASE-COM}.

If the establishment of the MAC service (IN minimum delay - full slot or IN normal delay - double slot) which is requested has been successful, then the DIPS shall send a DECT {CC-CONNECT} message to the DIFS.

Upon reception of the DECT {CC-CONNECT} message, the DIFS shall connect internally the DLC LU service (LU1/FU1 or LU7/FU7) to the MAC service created by the DIPS.

After successful establishment of the U-plane, the DIFS shall respond to the DIPS by sending a DECT {CC-CONNECT-ACK} message.

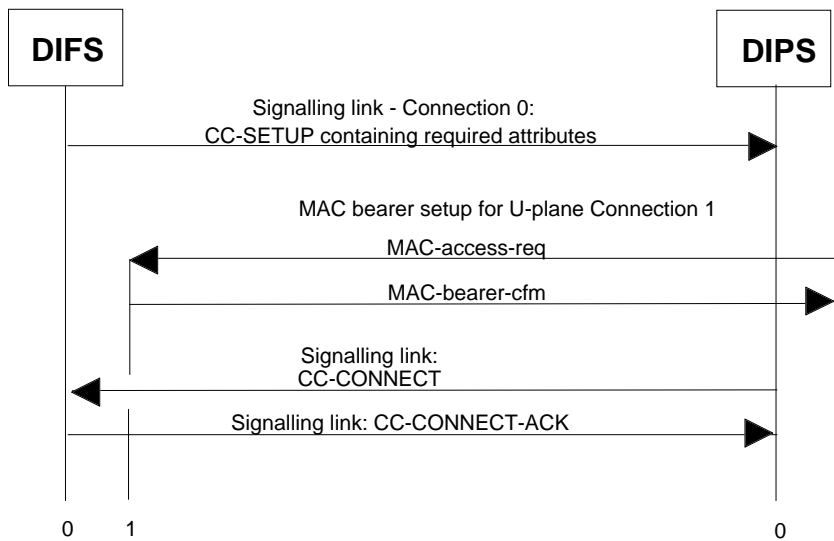

Figure 8: Successful establishment of a U-plane-connection

The MAC layer shall use advanced connection setup procedure. The U-plane mapping U32a for full slots and U80a for double slots shall be used.

If the DIPS is unable to set up the required connection within the time T200 MAC timer (see ETS 300 175-3 [3], subclause 10.2.4.2), then the DIPS shall respond with a CC-RELEASE-COM message.

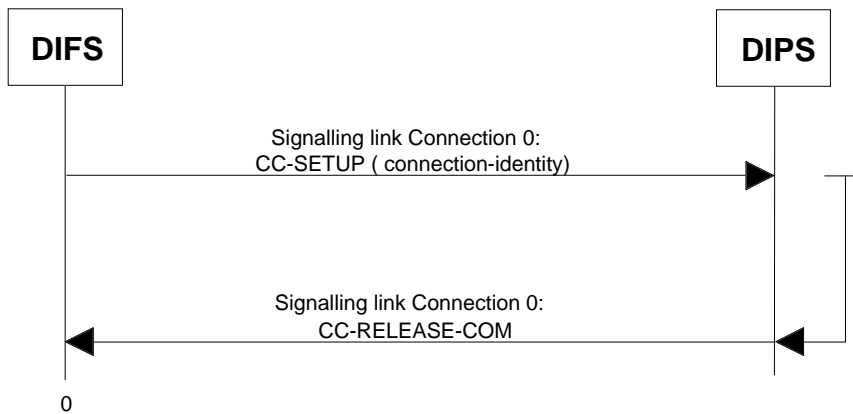

Figure 9: Unsuccessful establishment of a U-plane-connection

If the DIFS detects, that the U-plane is no longer necessary (e.g. for the held calls), then the DIFS shall send a DECT {CC-RELEASE} message to the DIPS. See also subclauses 6.7.1 and 6.7.3.

Upon reception of the DECT {CC-RELEASE} message, the DIPS shall release, the DLC LU service and MAC IN service association, and, the DECT U-plane and ISDN B-channel association. Afterwards, the DIPS shall release the MAC bearer used for the MAC IN service.

After release of the MAC bearer, the DIPS shall answer to the DIFS by sending a DECT {CC-RELEASE-COM} message.

Upon reception of the DECT {CC-RELEASE-COM} message, the DIFS shall release, the DLC LU service and MAC IN service association, and, the DECT U-plane and ISDN B-channel association.

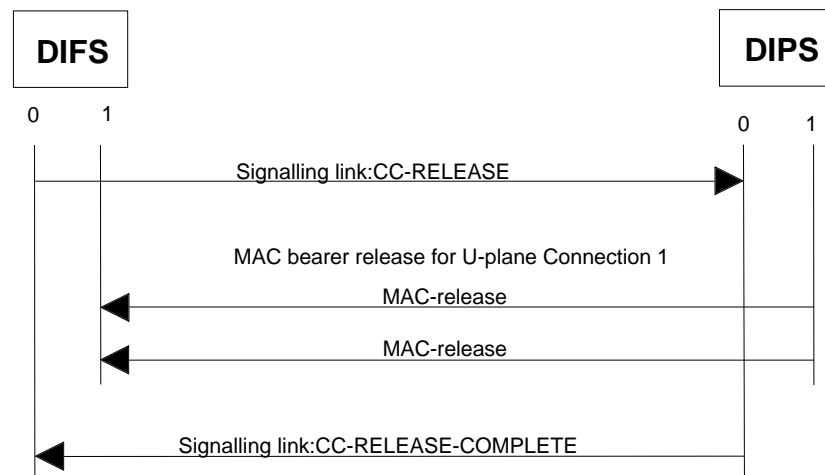

Figure 10: Release of a U-plane-connection

6.3.2 B-channel management

The B-channel to be used is identified by the ISDN <<Channel-Id>> IE contained in some ISDN layer 3 messages. These ISDN layer 3 messages, depending on services, are:

```

{SETUP};
{SETUP-ACK};
{CALL-PROCEED};
{ALERTING};
{CONNECT};
{CONNECT-ACK};
{RETRIEVE};
{RETRIEVE-ACK};
{RESUME-ACK};
{RESTART};
{RESTART-ACK}.
  
```

The DIFS shall analyse these messages, shall detect the final choice of the B-channel number, and shall connect the B-channel to the associated U-plane and ISDN interface. Then, the DIFS shall inform the DIPS upon the B-channel to be connected to the associated U-plane and ISDN interface at DIPS side. For an incoming call the connection of the B-channel and the according command given to the DIPS shall be performed upon detection of the CONNECT-ACK message received from the network. For outgoing and retrieved calls the connection of a B-channel shall be performed as soon as the B-channel can be identified from the analysed ISDN-L3 messages. The DIFS shall use the DECT {IWU-INFO} message to inform the DIPS of the B-channel connection.

The B-channel so far connected shall be disconnected at both ISDN interfaces upon the detection of the following events:

- reception of a DISCONNECT message without the "progress indicator IE indicating inband information;
- reception of a RELEASE message with "cause" IEs other than #26 (non-selected user clearing);
- reception of a RELEASE-COMPLETE message;
- reception of a HOLD-ACK message;
- reception of a SUSPEND-ACK message.

The reception of clearing messages from terminals the B-channel is not allocated to, shall not cause disconnection of the B-channel. The DIFS-IWU shall use the DECT <<IWU-INFO>> message to inform the DIPS about handling of the B-channel. CC-REL can be used if disconnection of the B-channel coincides with the release of the U-plane.

6.4 L2 address management

The L2 address management for the TE1s at the portable side is done locally at the DIPS.

The L2 address management for the DIFS is controlled by the ISDN network.

The DIFS and the DIPS shall sustain a function, that ensures real association between the network side and terminal side ISDN layer 2 link. To provide this purpose, every ISDN layer 3 message conveyed across DECT air interface is accompanied by a ISDN layer 2 identifier. This identifier allows the receiving side (DIFS or DIPS) to map this message to the corresponding ISDN layer 2 link.

If an ISDN layer 2 link is established by the ISDN system at one side, this event shall be reported across the DECT air interface to the other side (DIPS or DIFS). Upon reception of this message, the receiving side shall initiate the establishment of the corresponding ISDN layer 2 link.

The mapping between the L2 address at the fixed side and the portable side shall be done by the DIFS.

If an ISDN layer 2 link is released at one side, this event shall be reported across the DECT air interface to the other side (DIPS or DIFS). Upon reception of this message, the receiving side shall initiate the release of the corresponding ISDN layer2 link. The address contained in this received message shall be removed from the mapping table.

Removal of TEIs for the DIFS is controlled by the ISDN network and no notification message is sent to the DIPS.

6.5 Outgoing call procedures

Upon reception of a layer 2 establishment message from a TE1, the DIPS shall establish a signalling link to the DIFS (if no link previously established) as described in subclause 6.2.3. The DIPS shall initiate the establishment of the ISDN layer 2 link at the network side by sending a DECT message to the DIFS. Upon reception of this DECT message, the DIFS shall establish an ISDN layer 2 link with the ISDN network.

Upon reception of a {SETUP} message from the TE1, the DIPS shall forward the message to the DIFS in a DECT {IWU-INFO} message.

The DIFS shall analyse the <<BEARER-CAPABILITY>> IE of the ISDN {SETUP} message contained in the DECT {IWU-TO-IWU} IE of the DECT {IWU-INFO} message to determine the required attributes for the associated DECT U-plane. A DECT bearer supporting the U-plane shall be established according the service mapping described in table 2 (subclause 6.3.1).

The DIFS shall forward the ISDN {SETUP} message to the ISDN network on the previously established ISDN layer 2 link.

The DIFS shall forward the ISDN layer 3 response to the DIPS by using an <<IWU-TO-IWU>> IE carried by the DECT {IWU-INFO} message.

Upon reception of the ISDN layer 3 response contained in a <<IWU-TO-IWU>> in the DECT {IWU-INFO} message, the DIPS shall send this message on the ISDN layer 2 link.

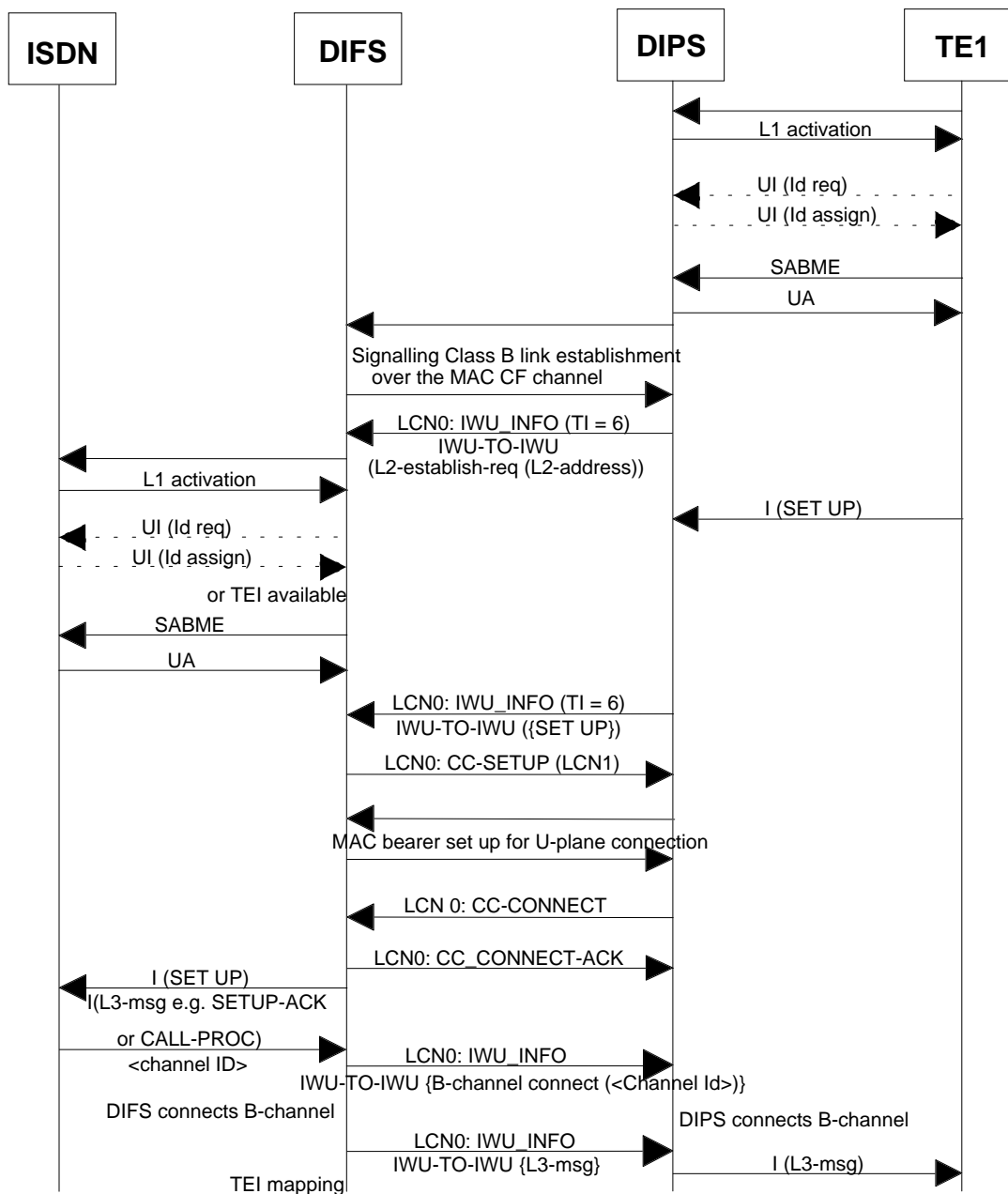

NOTE: The ISDN SETUP message may be forwarded to the network before or during the establishment of the DECT U-plane.

Figure 11: DECT Intermediate system: outgoing call with U-plane required

The first {IWU-INFO} message sent by the DIPS shall contain the <<Portable-Identity>> IE.

The first {IWU-INFO} message sent by the DIPS may be contained in the establishment Class B DLC I-frame.

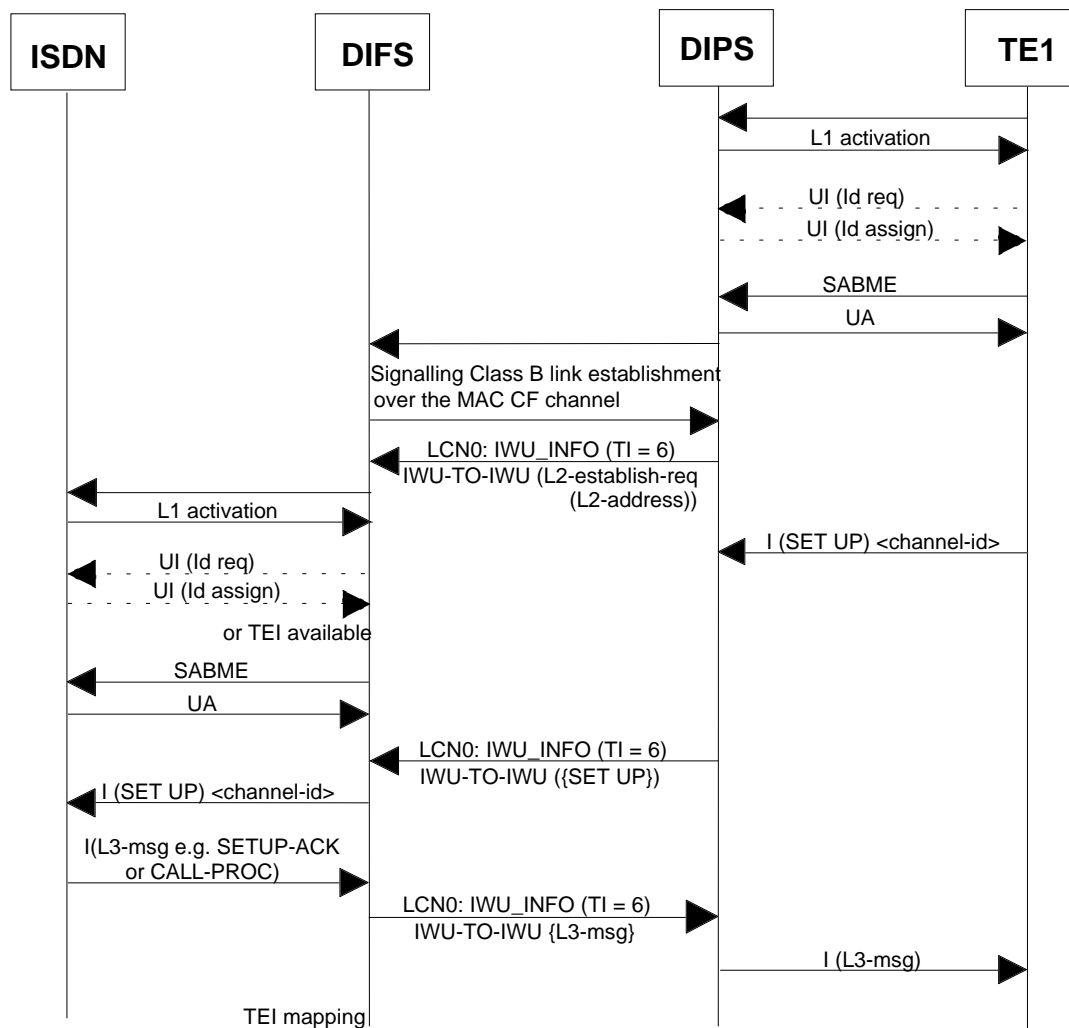

Figure 12: DECT intermediate system: outgoing call with no U-plane required; example for a user signalling bearer service call.

6.6 Incoming call procedures

6.6.1 Point to multipoint configuration

Upon reception of an ISDN layer 2 UI-frame containing a {SETUP} message (or equivalent ISDN message) from the ISDN network, and if no previously signalling link is established, the DIFS shall set up a signalling link to the DIPS as described in subclause 6.2.2. Then the DIFS shall analyse the <<BEARER-CAPABILITY>> IE of the ISDN {SETUP} message to determine the required attributes for the associated DECT U-plane.

Depending on these required attributes, the DIFS shall request the DIPS to establish a relevant dedicated U-plane service as described in subclause 6.3.

The DIFS shall forward the ISDN {SETUP} message to the DIPS (broadcast TEI) by using an <<IWU-TO-IWU>> IE indicating ISDN unnumbered I-frame and carried by a DECT {IWU-INFO} message.

The DIFS may establish, in advance, an ISDN layer 2 link with the ISDN network, otherwise the ISDN layer 2 link shall be established upon request from the DIPS.

Upon reception of the first ISDN layer 3 response contained in a <<IWU-TO-IWU>> of a DECT {IWU-INFO} message, the DIFS shall send this message on the previously established ISDN layer 2 link identified by the L2 address mapped from the address accompanying the L3 message in the IWU-INFO message.

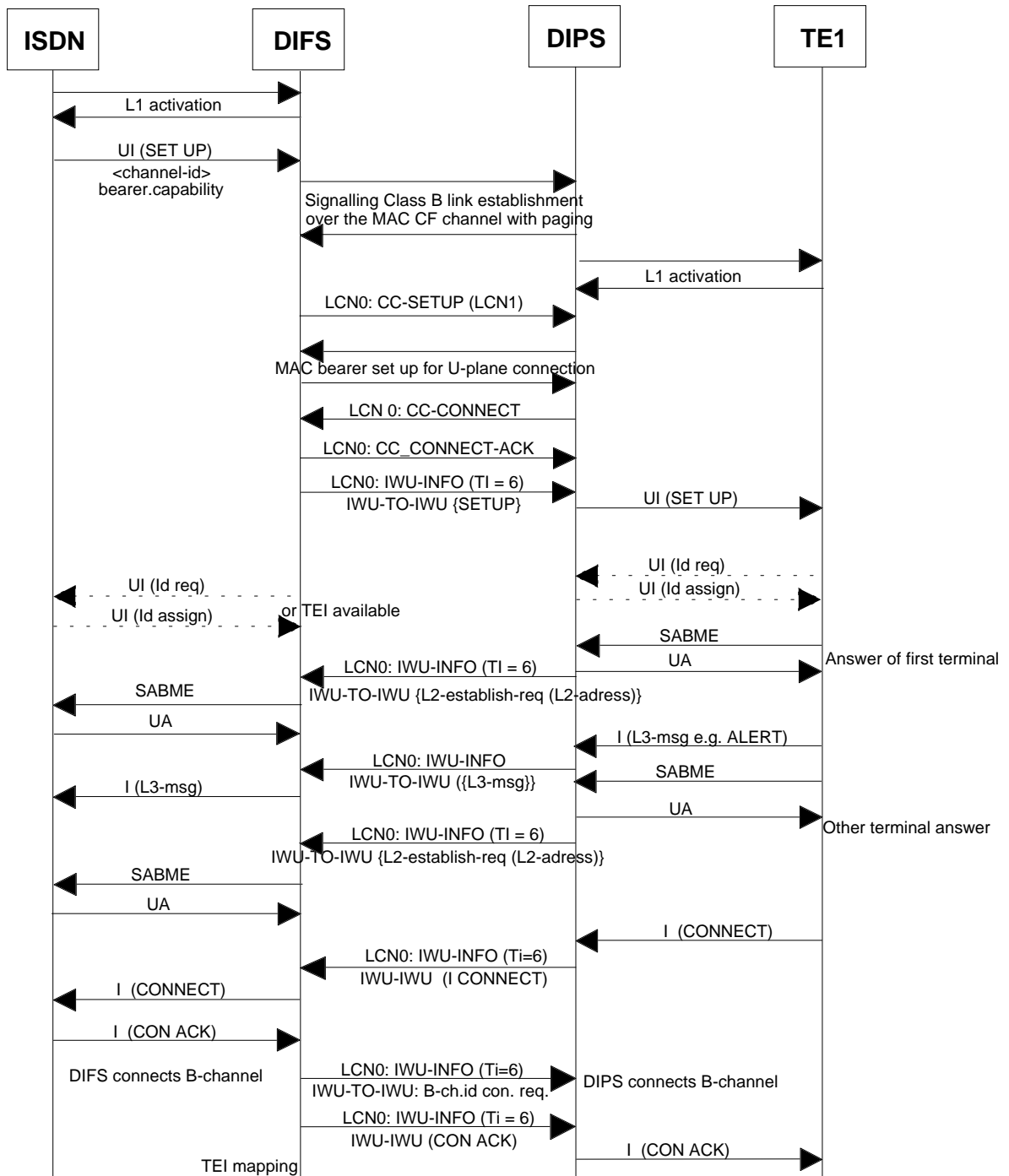

NOTE 1: Activation of layer 2 towards the network may be done earlier before L2 establish request is received.

NOTE 2: The ISDN {SETUP} message may be forwarded to the terminal before or during the establishment of the DECT U-plane.

Figure 13: DECT intermediate system: incoming call with U-plane required - point to multipoint configuration

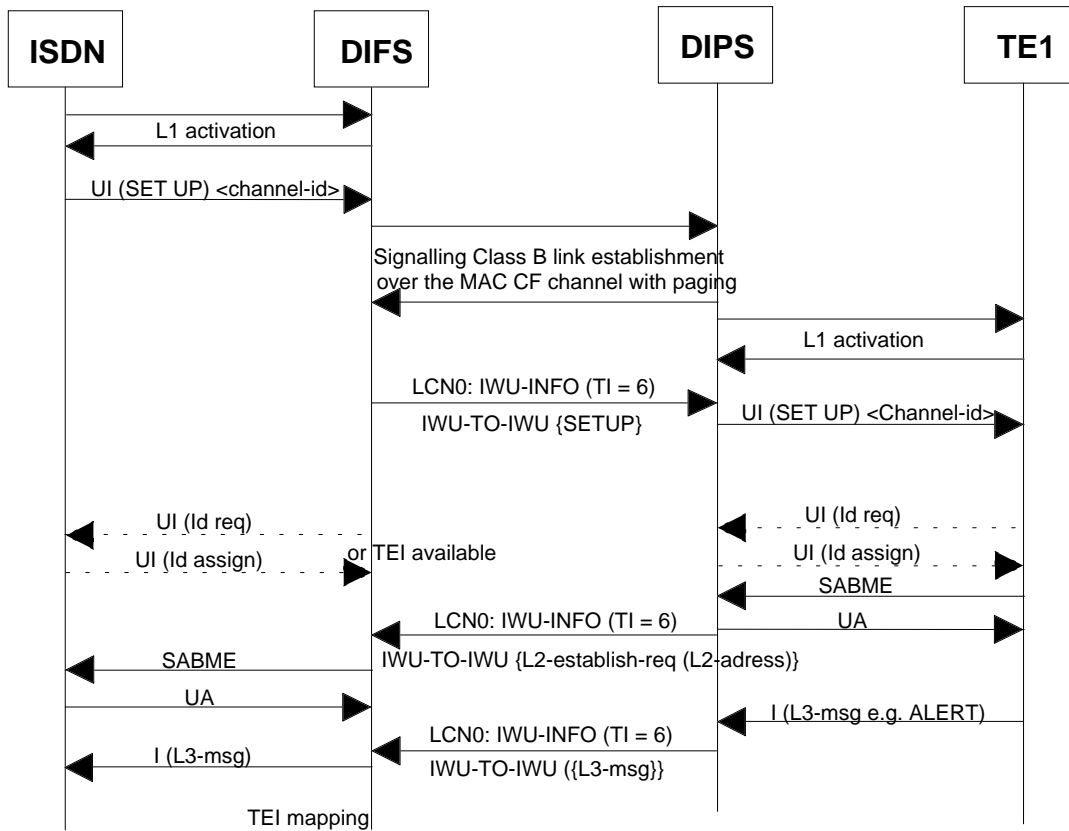

NOTE: Activation of layer 2 towards the network may be done earlier before L2 establish request is received.

Figure 14: DECT intermediate system: incoming call with no U-plane required - point to multipoint configuration; example for a user signalling bearer service call

6.6.2 Point to point configuration

Upon reception of an ISDN layer 2 activation, and if no previously signalling link is established, the DIFS shall set up a signalling link to the DIPS as described in subclause 6.2.2. Then, upon reception of an ISDN layer 2 information frame containing a {SETUP} message from the ISDN network, the DIFS shall analyse the <<BEARER-CAPABILITY>> IE of the ISDN {SETUP} message to determine the required attributes for the associated DECT U-plane.

Depending on these required attributes, the DIFS shall request the DIPS to establish a relevant dedicated U-plane service as described in subclause 6.3.

The DIFS shall forward the ISDN {SETUP} message to the DIPS by using an <<IWU-TO-IWU>> IE indicating ISDN numbered I-frame and carried by a DECT {IWU-INFO} message.

Upon reception of the first ISDN layer 3 response contained in a <<IWU-TO-IWU>> of a DECT {IWU-INFO} message, the DIFS shall send this message on the ISDN layer 2 link.

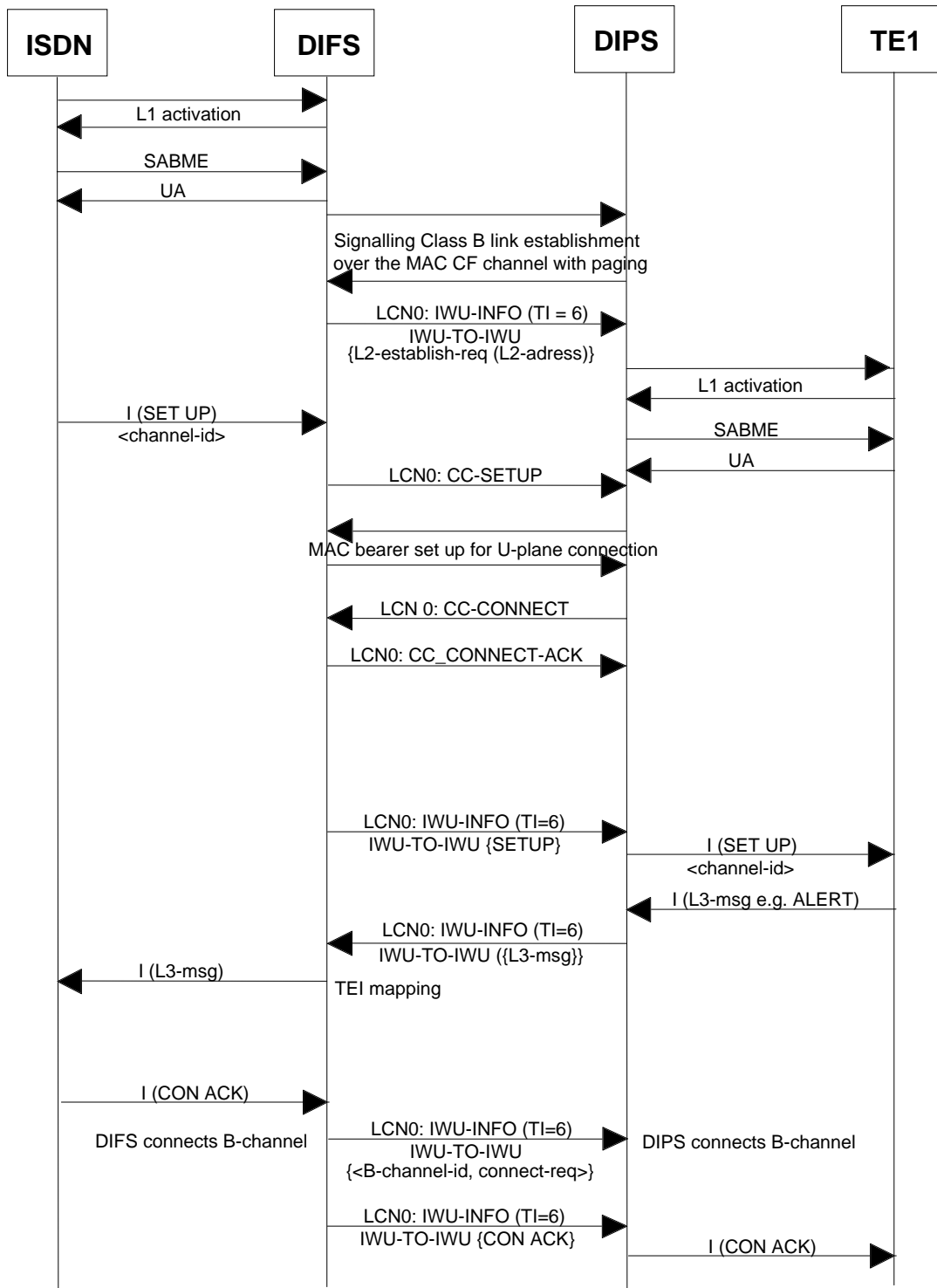

Figure 15: DECT intermediate system: incoming call with U-plane required - point to point configuration

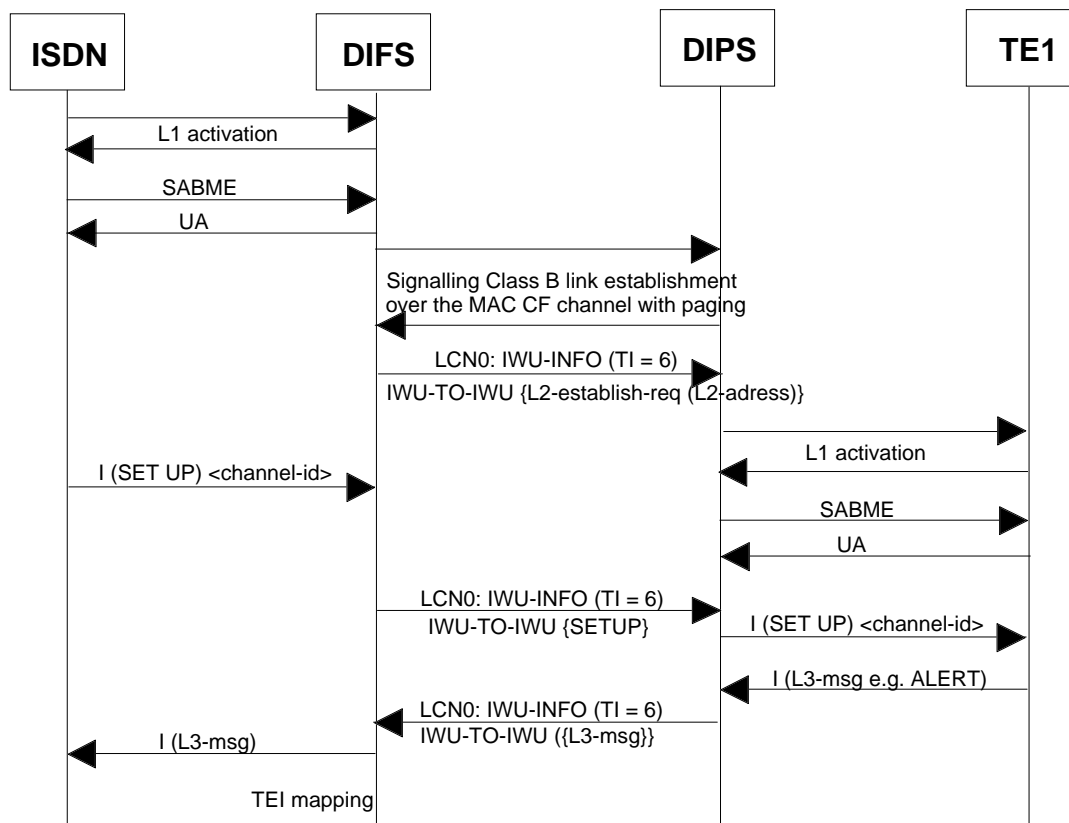

Figure 16: DECT intermediate system: incoming call with no U-plane required - point to point configuration, example for an user signalling bearer service call

6.7 Release procedures

6.7.1 Release from the ISDN network

The release of the DECT U-plane and the disconnection of the B-channel shall mainly follow the clearing of a call as specified for ISDN in ITU-T Recommendation Q.931 [26] together with ETS 300 403-1 [14], subclause 5.3. As a main guideline can be taken that the U-plane can be released and the B-channel be disconnected if disconnection of the B-channel is specified for ISDN. Concerning the release the additional conditions as described below exists.

Conditions:

- the U-plane supporting held calls shall not be released;
- if a full slot U-plane is carried by a DECT bearer, which also contains the signalling link in the C_S field, the signalling link shall be switched to the C_S of an other active DECT bearer if present. Otherwise the DECT-bearer shall not be released;
- if a double slot U-plane is carried by a DECT-bearer which also contains the signalling link in the C_S field, the signalling link shall be switched either to the C_S of an other active bearer or, if not present, to the C_S of a new full slot DECT bearer. The double slot bearer shall then be released.

Figure 17 provides an example for normal clearing of a circuit switched call for the case that there are no further calls requiring support by the U-plane. The DISC message contains the <progress indicator> IE indicating inband information in this example.

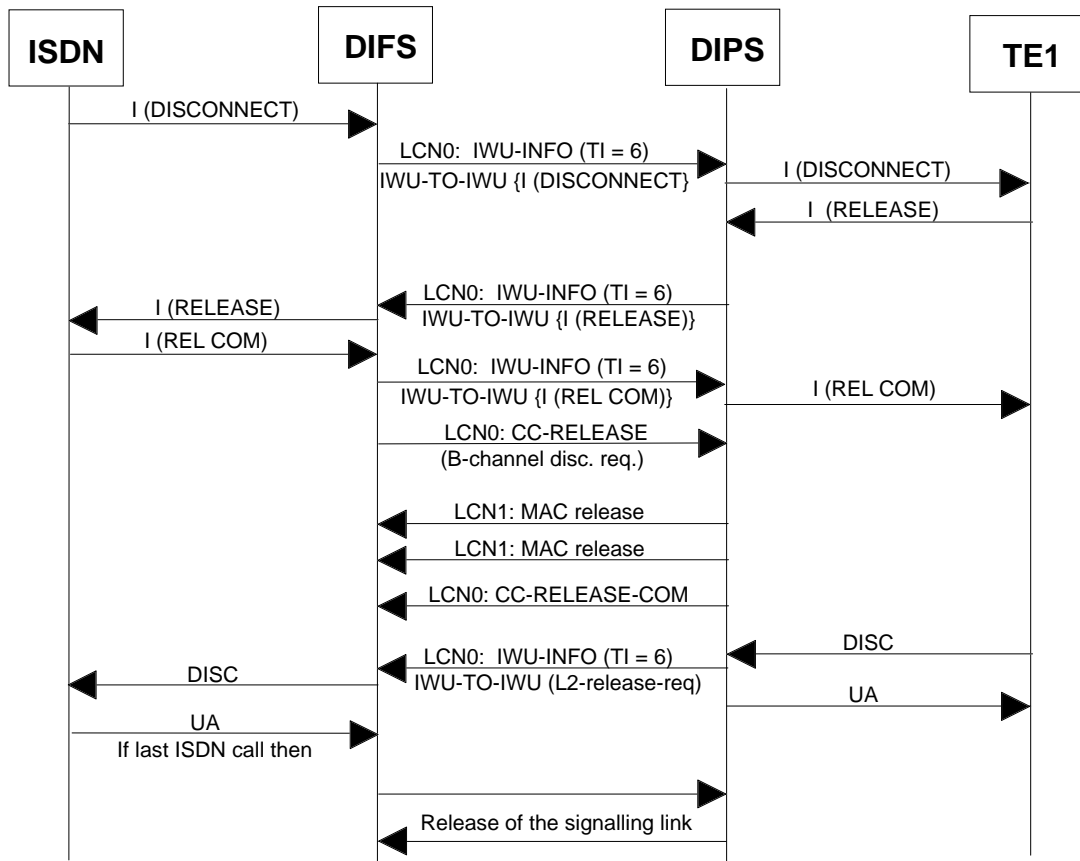

NOTE 1: If the B-channel has not been disconnected before, the CC-REL message shall contain the B-channel disconnect command.

NOTE 2: Release of the U-plane can overlap with the completion of the ISDN call clearing.

Figure 17: DECT intermediate system: release from ISDN network

6.7.2 L2 disconnection from the ISDN network (point to point only)

Upon reception of an ISDN L2 disconnection from the ISDN network, the DIFS shall forward the ISDN L2 disconnection to the DIPS by sending it in an <<IWU-TO-IWU>> IE of a relevant DECT message.

Upon reception of the "L2 release request", the DIPS shall disconnect the ISDN layer 2 link with the ISDN terminal.

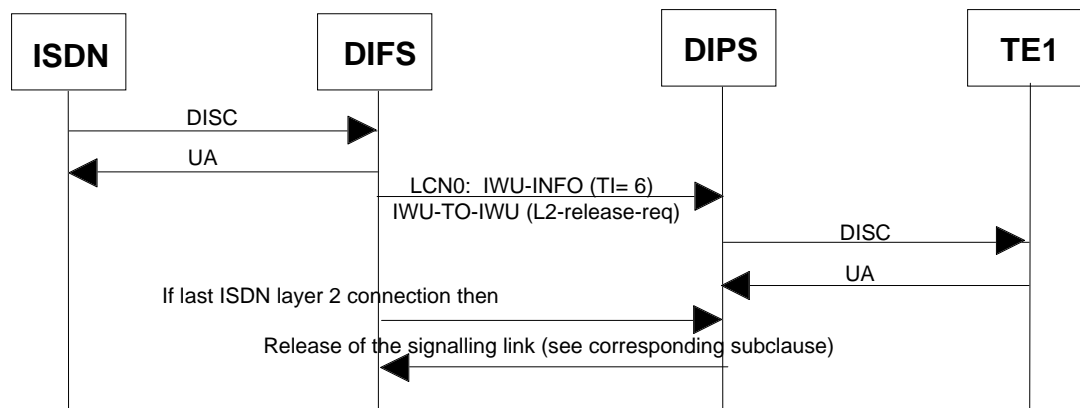

Figure 18: DECT intermediate system: L2 disconnection from ISDN network

6.7.3 Release from the ISDN terminal

The release of the DECT U-plane and the disconnection of the B-channel shall mainly follow the clearing of a call as specified for ISDN in ITU-T Recommendation Q.931 [26] together with ETS 300 403-1 [14], subclause 5.3.

Additional conditions exist concerning the release of the DECT U-plane, see subclause 6.1.6.1 of this ETS. In a point-to-multipoint configuration the DECT U-plane shall furthermore not be released:

- upon immediate rejection of the call by a TE;
- as long as the call, not yet being allocated to one TE, has not been released by all TE's which had sent a positive response upon the incoming SETUP message.

Figure 19 provides an example of the normal clearing of a circuit switched call for the case that the U-plane is not further required for held calls.

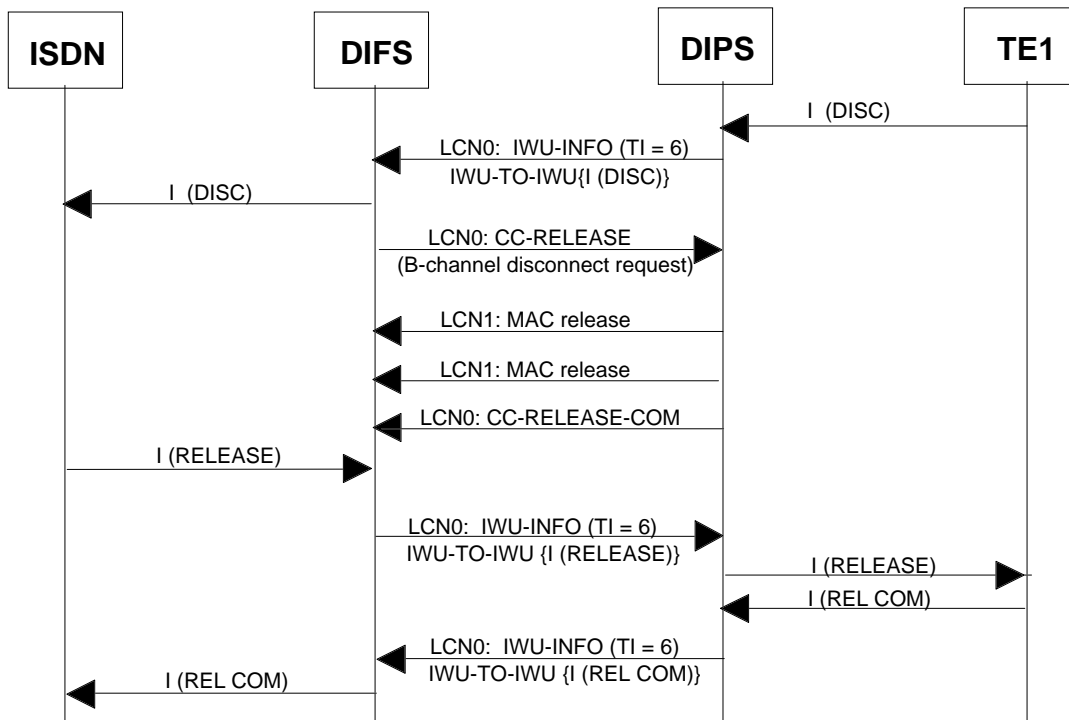

NOTE 1: If the B-channel has not been disconnected before, then the CC-REL message shall contain the B-channel disconnect command.

NOTE 2: Release of the U-plane can overlap with the completion of the ISDN call clearing.

Figure 19: DECT intermediate system: release from TE1

6.7.4 L2 disconnection from the ISDN terminal

Upon reception of an ISDN L2 disconnection from the ISDN terminal, the DIPS shall forward the ISDN L2 disconnection to the DIFS by sending it in an <<IWU-TO-IWU>> IE of a relevant DECT message.

Upon reception of the DECT {IWU-INFO} message containing the ISDN L2 disconnection, the DIFS shall release the ISDN layer 2 link with the network.

In case of no other ISDN layer 2 connection are active or pending, then the DIFS shall release the DECT signalling link as described in subclause 6.2.4.

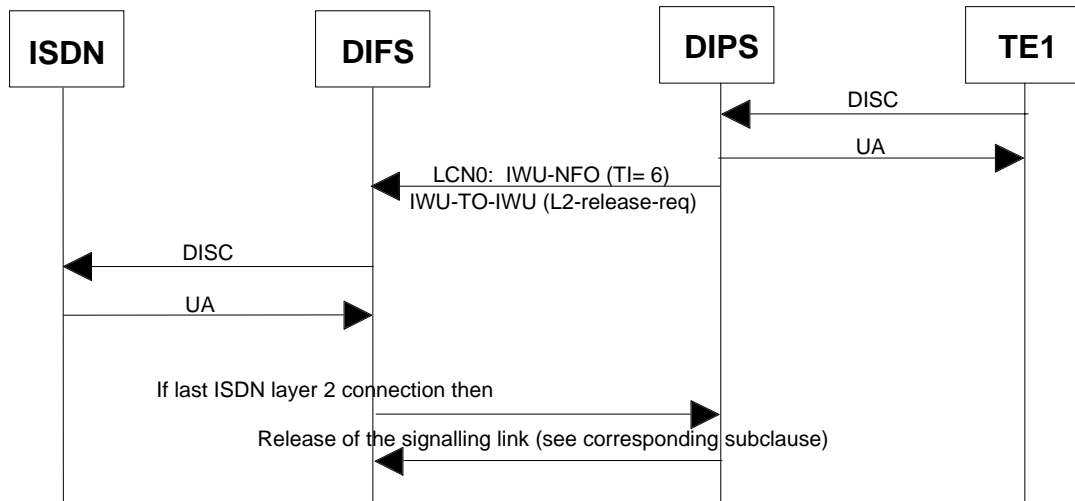

Figure 20: DECT Intermediate System: L2 disconnection from TE1

7 Physical layer procedures

7.1 General requirement

Physical layer at DIPS or DIFS has, at least, to support full slot and double slot packets.

7.2 Minimum Normal Transmit Power (NTP)

The nominal NTP shall be greater than 80 mW per simultaneously active transmitter (see ETS 300 175-2 [2]).

7.3 Radio receiver sensitivity

The radio receiver sensitivity shall be -86 dBm, or better.

7.4 Z-field requirement

The Z-field shall be transmitted by RFPs of the DIFS and by PT of the DIPS.

7.5 Sliding collision detection

DIPS and DIFS shall be able to detect sliding collision on received packets.

Minimum criteria for sliding collision is defined as S- or Z-field failure. Early sliding collision detection may be supported by other means e. g. signal strength measurements in the guard band.

The Z-field is defined to have failed if the received X- and Z-fields are not identical.

S-field failure is defined with some tolerance in order not to restrict the physical implementation of the word synchronization detector.

S-field failure may be indicated if there are 1 or more bit errors in bits s12 to s31 (errors in bits s0 to s11 shall be ignored). In all cases, S-field failure shall be indicated if 3 or more bit errors occur in bits s16 to s31.

7.6 Physical channel availability

A DIFS shall be able to receive and transmit on all DECT frequencies f_0 to f_9 and at least half of the slot pairs 0 - 11.

A DIPS shall be able to receive and transmit on all DECT frequencies f_0 to f_9 , and shall be able to lock on any slot number 0 - 11, and receive and transmit at least on every slot pair that is not directly neighboured to the slot the DIPS is locked to, or to a slot on which a traffic bearer is active at the DIPS.

7.7 Synchronization window

Related to its reference timer, the DIPS synchronization window shall be at least ± 4 bits for bearers to the RFP of the DIFS to which the reference timer is synchronized, and at least ± 10 bits for other bearers.

8 MAC layer procedures

This clause refers to elements specified in ETS 300 175-3 [3]. The DIFS and DIPS shall provide at least all of the elements stated below plus the mandatory elements of the ETS 300 175-3 [3].

8.1 MAC layer signalling procedures

Without either any ISDN call in progress or any ISDN layer 2 or 3 signalling ongoing, there is no bi-directional DECT link established. Only the broadcast link in the direction DIFS to DIPS exists.

8.1.1 Downlink broadcast

The DIFS shall perform the procedure as indicated in ETS 300 175-3 [3], subclause 9.1.1 with the following specifications.

8.1.1.1 N_t message

The DIFS shall be capable to send and the DIPS shall be capable to receive and process the N_t message as defined in subclause 7.2.2 in ETS 300 175-3 [3].

Table 3: Values used within N_t message

MAC message/broadcast element	Field within the message/broadcast element	Standard values within the MAC message	Normative action/comment
<<RFPI>>			
	<E-bit>	0	No SARI.
		1	SARI available.
	<PARI>	All	
	<RPN>	All	

RFPI information: the LLME in the DIPS supplies its MAC with the PARI with an SDU (either 32 or 37 bits) passed via the ME SAP and the DIFS add its RPN.

8.1.1.2 Q_t - static system information

The DIFS shall be capable to send and the DIPS shall be capable to receive and process the Q_t message as defined in subclause 7.2.3.2 in ETS 300 175-3 [3].

Table 4: Values used within static system info

MAC message	Field within the message	Standard values within the MAC message	Normative action/comment
<<Static system info>>			
	<Q _H >	0	
	<NR>	0	Asymmetric connections are not required.
	<SN>	0-11	DIPS shall support all values.
	<SP>	0	Half slot connections are not required to be supported by the DIPS.
	<ESC>	0	DIPS may ignore and assume the value to be 0.
	<Txs>	0	DIPS may ignore and assume the value to be 0.
	<Ext-car>	0,1	DIPS shall support all values in order to keep in synchronization with the primary scan.
	<RF-car>	1-1023	The DIPS shall not use carriers which are not supported.
	<SPR>	0	DIPS may ignore.
	<CN>	0-9	DIPS shall support all values.
	<SPR>	0	DIPS may ignore.
	<PSCN>	0-N	DIPS shall support values 0-9.

8.1.1.3 Q_t - FP capabilities

The DIFS shall be capable to send and the DIPS shall be capable to receive and process the Q_t message as defined in subclause 7.2.3.4 in ETS 300 175-3 [3].

Table 5: Values used within FP capabilities

MAC message	Field within the message	Standard values within the MAC message	Normative action/comment
<<FP capabilities>>			
	<Q _H >	3	
	<a12>	1	Extended FP info (Q _H = 4)
	<a15>	1	Double slot
	<a17>	1	Full slot
	<a19>	1	Page repetition
	<a25>	1	B-field setup
	<a26>	1	C _F messages
	<a27>	1	I _n minimum delay
	<a28>	1	I _n normal delay

Higher layer information: the LLME in the DIPS supplies its MAC with a 16 bit SDU via the ME SAP. At the DIPS the MAC passes the 16 bits out through the ME SAP to the LLME.

The DIPS and DIFS shall support the C_S and C_F channels defined in ETS 300 175-3 [3], subclause 5.3.1.1.

The DIPS and DIFS shall support the C_S and C_F channel data transfer procedures defined in ETS 300 175-3 [3], subclause 10.8.1.

The DIPS and DIFS shall support the E/U MUX types E32 and E80 and types U32 and U80 defined in ETS 300 175-3 [3], subclause 6.2.2.2.

The DIPS and DIFS shall support the Establishment of a single bearer duplex connection, defined in ETS 300 175-3 [3], subclause 10.2.4.2.

The DIPS and DIFS shall support the B-field advanced single bearer setup procedure PT initiated, defined in ETS 300 175-3 [3], subclause 10.5.1.3.1.

The DIFS shall support the page repetition capability as defined in ETS 300 175-3 [3], subclause 9.1.3.1.

8.1.1.4 Q_t Extended FP capabilities

The DIFS shall be capable to send and the DIPS shall be capable to receive and process the Q_t message as defined in subclause 7.2.3.5 in ETS 300 175-3 [3].

Table 6: Values used within extended FP capabilities

MAC message	Field within the message	Standard values within the MAC message	Normative action/comment
<<extended FP capabilities>>			
	< Q_H >	4	
	<a42>	1	ISDN Intermediate system

8.1.1.5 Q_t - SARI list contents

The DIFS may send and the DIPS shall be capable to receive and process (if DIFS broadcast it) the Q_t message as defined in subclause 7.2.3.6 in ETS 300 175-3 [3] (relevant if the N_t message indicates SARI support).

Table 7: Values used within SARI list contents

MAC message	Field within the message	Standard values within the MAC message	Normative action/comment
<<SARI list contents>>			
	< Q_H >	5	
	<SARI list length>	All	
	<TARIs yes/no>	All	The DIPS may ignore it if TARI request is not supported.
	<Black yes/no>	All	The DIPS shall be able of distinguishing ARI from black ARI even if TARI is not supported.
	<ARI or black-ARI>	All	

8.1.1.6 Paging broadcast: short page

The procedure shall be performed as defined in subclause 9.1.3 in ETS 300 175-3 [3] with the following specifications.

The following fields as defined in subclause 7.2.4 in ETS 300 175-3 [3] in the short page message, shall be supported by the DIPS and the DIFS.

Table 8: Values used within short page message

MAC message	Field within the message	Standard values within the MAC message	Normative action/comment
<<Short page message>>			
	<Extended flag>	0,1	DIPS shall support all values. Optional for the DIFS to support value 1.
	<B _S SDU length indication>	1	DIPS and DIFS shall support short page messages.
	<20 bits of B _S channel data>	All	Higher layer information.
	<Information type>	1, 2, 5 and 9	The DIPS shall support values 1, 2, 5, and 9. DIFS shall support value 1, if blind slot information available. The DIFS shall support value 9, if bearer handover information available. Other values need not be supported by DIFS or DIPS.
	<MAC layer information>	Corresponding information	Information type defined in the previous field.

The P_t format for short page message shall be used (see ETS 300 175-3 [3], subclause 7.2.4.1.2).

8.1.1.7 Paging broadcast: zero page

The following fields as defined in subclause 7.2.4 the ETS 300 175-3 [3] in the zero page message, shall be supported by the DIPS and the DIFS.

Table 9: Values used within zero page message

MAC message	Field within the message	Standard values within the MAC message	Normative action/comment
<<Zero page message>>			
	<Extend flag>	0,1	DIPS shall support all values. Optional for the DIFS to support value 1.
	<B _S SDU length indication>	0	DIPS shall support zero length page messages. The DIFS shall support if "Blind slot information" included.
	<20 least significant bits of RFPI>	All	20 least significant bits of RFPI. May be ignored by DIPS.
	<Information type>	1, 2, 5 and 9	The DIPS shall support values 1, 2, 5 and 9. DIFS shall support value 1, if blind slot information available. The DIFS shall support value 9, if bearer handover information available. Other values need not be supported by DIFS or DIPS.
	<MAC layer information>	Corresponding information	Information type defined in the previous field.

The P_t format for zero page messages shall be used (see ETS 300 175-3 [3], subclause 7.2.4.1.3).

8.1.2 Activation of the signalling connection

8.1.2.1 General requirement

The DIPS and DIFS shall support the B-field advanced single bearer setup procedure PT initiated defined in ETS 300 175-3 [3], subclause 10.5.1.3.1.

8.1.2.2 Activation from the ISDN network

The DLC in the DIFS issues the MAC_PAGE-req primitive to its MAC; the SDU contains 20 bits data information (B_S channel information).

Table 10: Information used within the MAC_PAGE-req primitive

Parameter	Information within the parameter	Normative action/comment
<<cluster ID>>	all clusters / an integer	
<<page type>>	normal or fast	
<<length of page field>>	20	
<<SDU>>	The data from the <<Message unit>> received in the DL_BROADCAST-req primitive	

The P_t format for short page messages shall be used (see ETS 300 175-3 [3], subclause 7.2.4.1.2). The DIFS shall repeat the transmission of the short page message in the three multiframe following the first transmission of the message, provided that the MAC layer lifetime has not expired. Repeats of page messages have priority over first transmission of new page messages.

The MAX layer retransmission procedure can be stopped by the LLME if a correct response from the paged DIPS is received at the LCE layer (LCE_PAGE_RESPONSE message).

The MAC in the DIPS, on receiving the P_t short page message, delivers the complete B_S -channel SDU to the higher layer with the MAC_PAGE-ind.

Table 11: Information used within the MAC_PAGE-ind primitive

Parameter	Information within the parameter	Normative action/comment
<<length of page field>>	20	
<<SDU>>		

The DLC in the DIPS sends a MAC_CON-req to the MAC layer with the MCEI which is used to identify all further primitives related to the connection and all the parameters necessary to define the wanted service.

Table 12: Values used within the MAC_CON-req primitive

Parameter	Information within the parameter	Normative action/comment
<<MCEI>>	MAC Connection Endpoint Identifier	
<<PMID>>	PMID	
<<CHO flag>>	Y/N	Y - if the connection is required for Connection handover
<< C_F required>>	Yes	
<<Slot type>>	full slot	
<<connection type>>	advanced	

The MAC in the DIPS shall initiate the establishment of the advanced connection using the PT-initiated B-field advanced single bearer setup procedure as defined in ETS 300 175-3 [3], subclauses 10.2.4.2 and 10.5.1.3.1; full slot, C_F channel (see ETS 300 175-3 [3], subclause 7.3.3.2). The C_F channel shall be used to transport the higher layer messages (see ETS 300 175-3 [3], subclause 10.8.1.2). The LCN (ECN) identifier for the advanced connection is assigned by the LLME.

If the signalling connection is already established, the DLC in the DIFS sends the MAC_CO_DATA-req to its MAC (using the same MCEI and LCN (ECN) of that connection) whose SDU contains the C_F data segment to be transmitted (see ETS 300 175-3 [3], subclause 8.4.3).

Table 13: Values used within the MAC_CO_DATA-req primitive

Parameter	Information within the parameter	Normative action/comment
<<MCEI>>	MAC Connection Endpoint Identifier	
<<transmit data channel type>>	C_F	
<<number of segments>>	{0,1,...30}	
<<SDU>>		

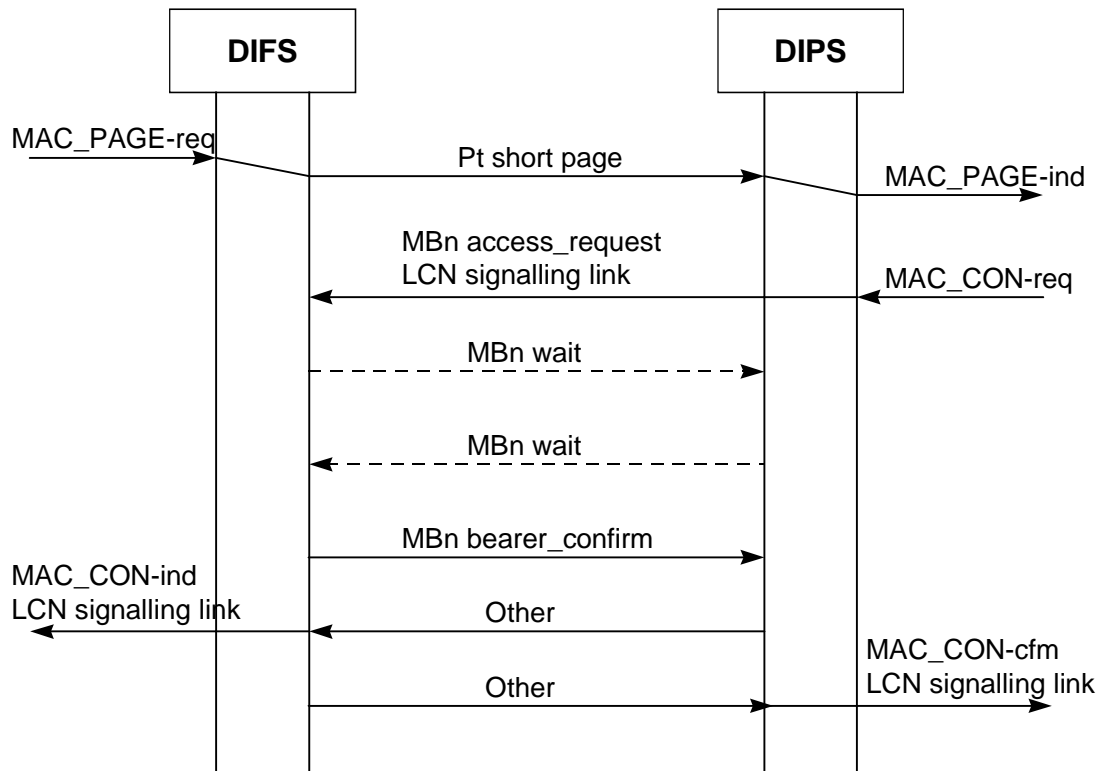

Figure 21: MAC layer signalling link setup scenario: activation from ISDN network

8.1.2.3 Activation from the ISDN terminal

The DLC in the DIPS sends a MAC_CON-req to the MAC layer with the MCEI which is used to identify all further primitives related to the connection and all the parameters necessary to define the wanted service.

Table 14: Values used within the MAC_CON-req primitive

Parameter	Information within the parameter	Normative action/comment
<<MCEI>>	MAC Connection Endpoint Identifier	
<<PMID>>	PMID	
<<CHO flag>>	Y/N	Y - if the connection is required for Connection handover
<<C _F required>>	Yes	
<<Slot type>>	full slot	
<<connection type>>	advanced	

The MAC in the DIPS initiates the establishment of the connection using the PT-initiated B-field advanced single bearer setup procedure (see ETS 300 175-3 [3], subclause, 10.5.1.3.1); full slot, C_F channel (see ETS 300 175-3 [3], subclause, 7.3.3.2). The C_F channel shall be used to transport the higher layer messages (see ETS 300 175-3 [3], subclause 10.8.1.2). The LCN (ECN) identifier for the advanced connection is assigned by the LLME.

If the signalling connection is already established, the DLC in the DIFS sends the MAC_CO_DATA-req to its MAC (using the same MCEI and LCN (ECN) of that connection) whose SDU contains the C_F data segment to be transmitted (see ETS 300 175-3 [3], subclause 8.4.3).

Table 15: Values used within the MAC_CO_DATA-req primitive

Parameter	Information within the parameter	Normative action/comment
<<MCEI>>	MAC Connection Endpoint Identifier	
<<transmit data channel type>>	C _F	
<<number of segments>>	{0,1,...30}	
<<SDU>>		

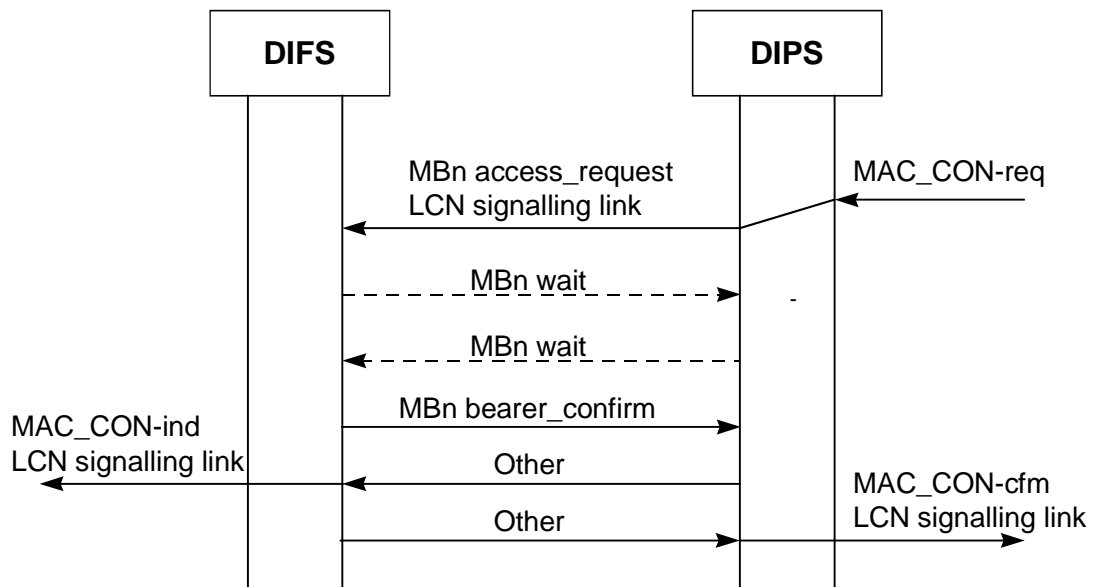

Figure 22: MAC layer signalling link setup scenario: activation from ISDN terminal

8.1.2.4 MBn advanced connection control messages

The following fields as defined in subclause 7.3.3 in ETS 300 175-3 [3] in the MAC control (MBn) messages shall be supported by the DIPS and the DIFS.

Table 16: Values used within MBn advanced connection control messages

MAC message	Field within the message	Standard values within the MAC message	Normative action/comment
<<MBn message>>			
	<MBn header>	X001	"Advanced connection control". X value depends on the B field contents
	<Command>	0	"Access_request"
		1	"Bearer_handover_request"
		2	"Connection_handover_request"
		4	"Bearer_confirm"
		5	"Wait"
	<FMID>	All	
	<PMID>	All	
	<ECN>	All	
	<LBN>	15	
	<up/down/sm/ss>	3	Symmetric single bearer connection
	<ser type>	101	"C-channel only"
	<max life>	0	
	<slot type>	0	Normal full slot
	<spr>	1111 B	

8.1.2.5 Associated procedure (s)

8.1.2.5.1 Timer T200 management

T200 Connection setup timer;
 Value 3 seconds (ETS 300 175-3 [3], annex A);
 Start At the creation of a MBC;
 Stop The TBC reports "bearer_established" or on request for MAC connection release.

8.1.2.5.2 Counter N200 management

N200 Max. number bearer setup re attempts during connection setup;
 Value 10 (ETS 300 175-3 [3], annex A);
 Start ACCESS_REQUEST is sent;
 Change A new ACCESS_REQUEST within the same connection setup attempt is sent;
 Clear The TBC reports "bearer_established" or on request for MAC connection release.

8.1.2.6 Exceptional case

8.1.2.6.1 Bearer setup fails or timer T200 expiry

The connection setup procedure is controlled by the timer T200.

At the DIPS side (calling side) the timer T200 is started at the reception of the MAC_CON-req from the DLC and the connection setup procedure has to be concluded within this timer. If the bearer setup attempt fails (see ETS 300 175-3 [3], subclause 10.5.1.3.1), the MBC at the DIPS can re-attempt with the same procedure up to N200 times within T200. Each re-attempt is reported to the DLC with a MAC_RES_DLC-ind primitive.

If the setup attempt fails N200 + 1 or T200 expires, the MAC in the DIPS releases both TBC and MBC and sends to its DLC the MAC_DIS-ind with the reason parameter set to indicate the setup attempt failure.

At the DIFS side (called side), T200 is started when the MBC is created (the bearer_confirm is sent). If T200 expires the MAC layer releases the TBC and MBC. The release of the MBC is always reported to the LLME and to its DLC with a MAC_DIS-ind primitive provided that a MAC_CON-ind primitive was issued before.

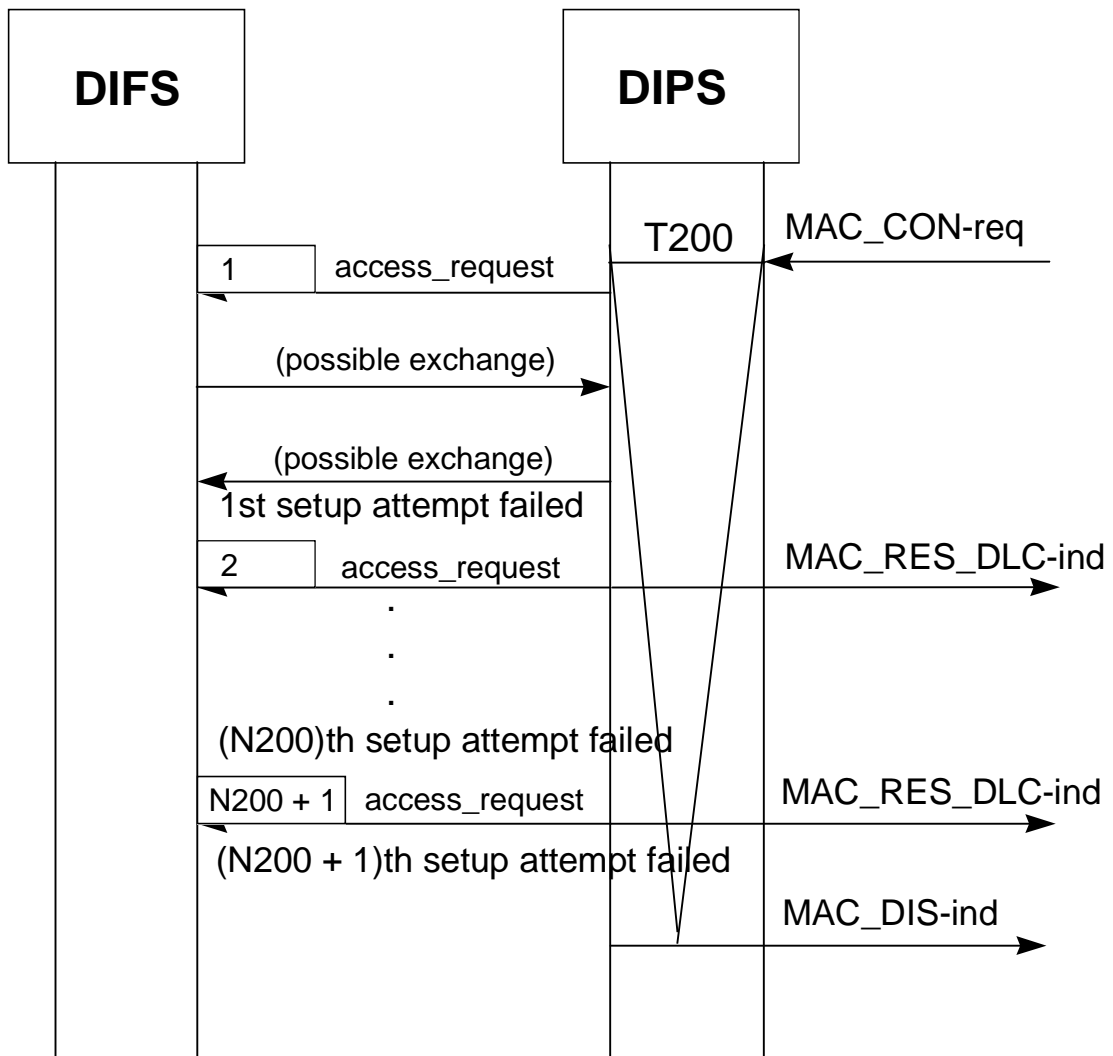

Figure 23: Bearer setup fails: N200 + 1 attempts failed

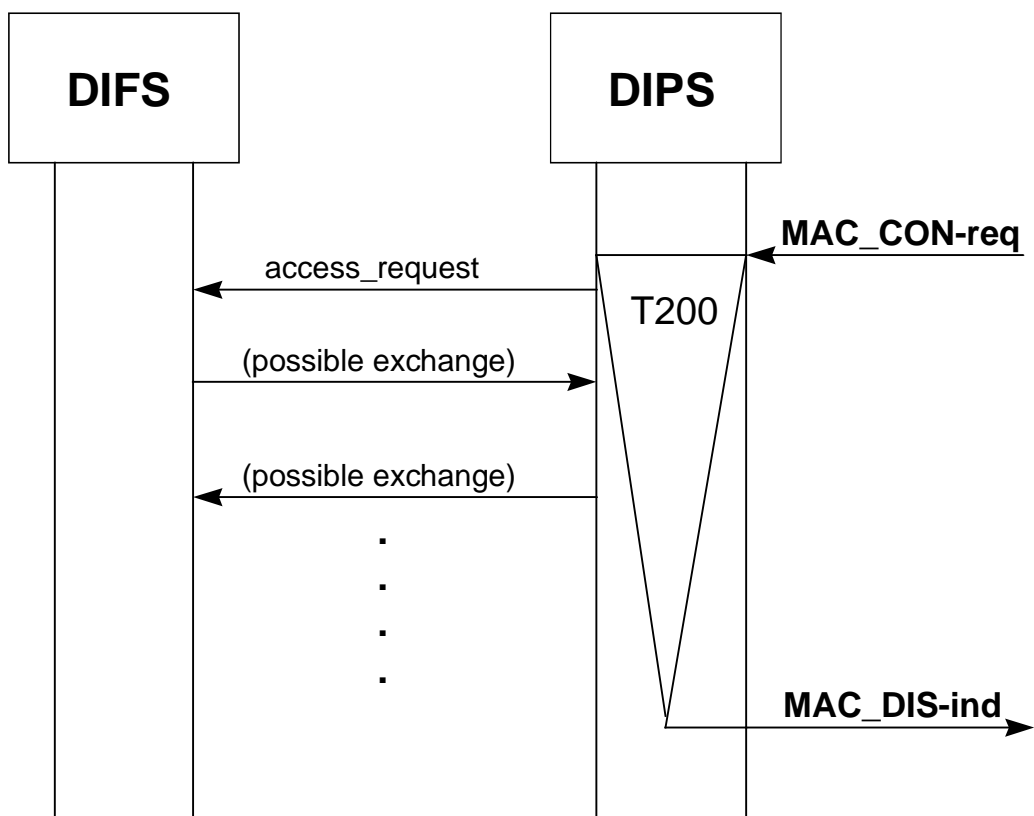

Figure 24: Timer T200 expiry

8.1.3 Release of signalling link

If no other DLC links are using the associated MAC signalling connection, the DLC shall immediately release this connection. The DLC in the DIFS or in the DIPS sends a MAC_DIS-req to the MAC layer with the MCEI of the signalling link.

Table 17: Information used within the MAC_DIS-req primitive

Parameter	Information within the parameter	Normative action/comment
<<MCEI>>		

The unacknowledged bearer release procedure shall be used (see ETS 300 175-3 [3], subclause 10.7.2.1). The MBn-release message in the B-field shall be used.

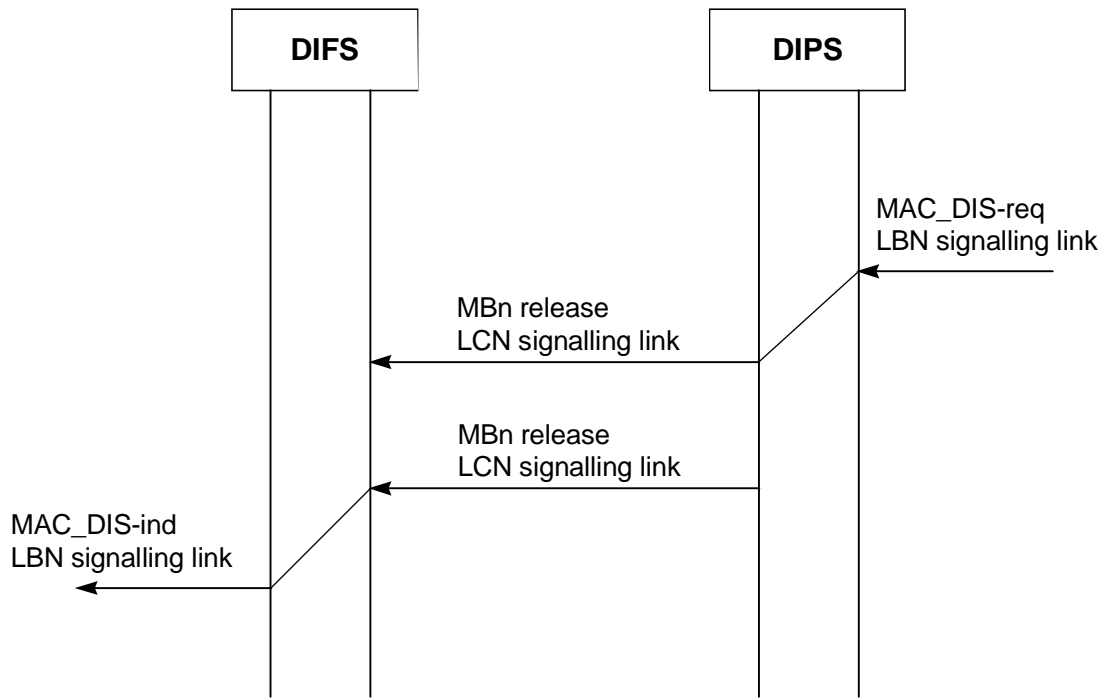

Figure 25: MAC layer signalling link release scenario: DIPS initiated

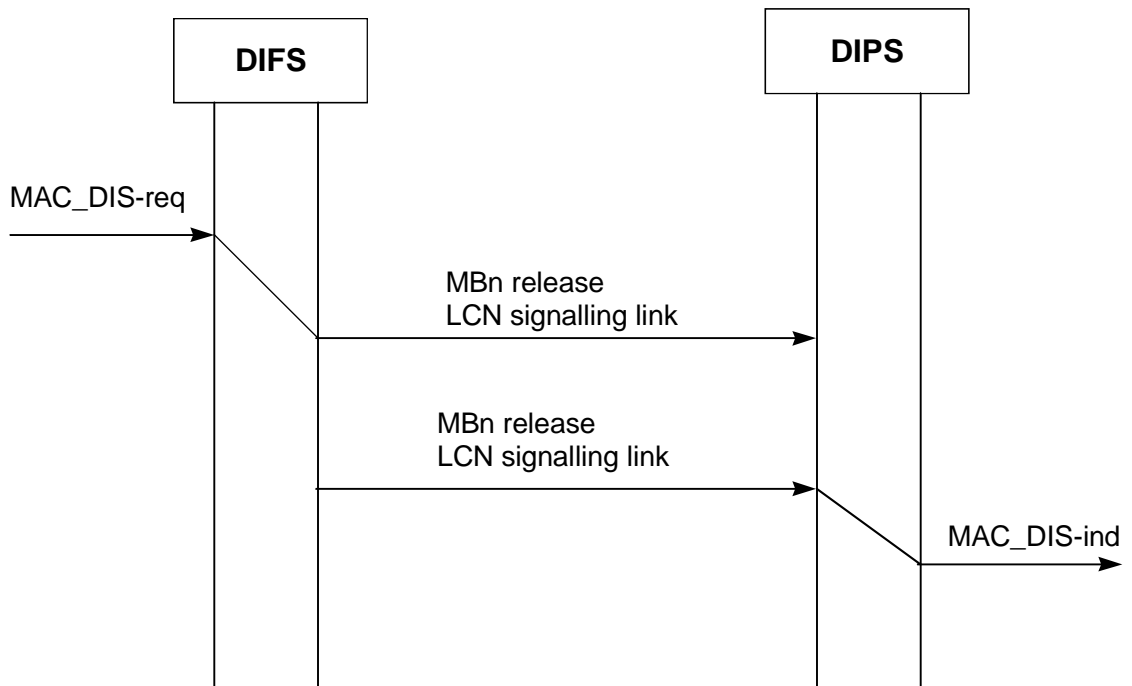

Figure 26: MAC layer signalling link release scenario: DIFS initiated

8.1.3.1 MBn release message

The following fields as defined in subclause 7.3.3.10 of ETS 300 175-3 [3] in the MAC control (MBn) message shall be supported by the DIPS and the DIFS.

Table 18: Values used within MBn release message

MAC message	Field within the message	Standard values within the MAC message	Normative action/comment
<<MBn message>>			
	<MBn header>	X001	"Advanced connection control". X value depends on the B field contents
	<Command>	15	"Release"
	<FMID>	All	
	<PMID>	All	
	<spr>	0000 B	
	<LBN>	All	
	<spare>	0000 1111 B	
	<reason>	All	

8.1.4 Dynamic C-plane switching: MAC layer procedures

8.1.4.1 Dynamic switching C_F to C_S: only DIFS initiated

The general procedure shall be performed as indicated in subclause 12.1. The following text together with the associated subclauses define the MAC layer requirements with regard to the general procedure.

Predicates:

The DIFS detects that the C_F channel, B-field, LCNx connection, is no longer necessary. The LLME at the DIFS knows that there is an already existing U-plane connection available for the D-channel. The switching is performed between two already existing connections: LCNx, C_F and LCNy U-plane (B-field) and C_S (A-field).

Procedure description:

Procedure description:

The MAC layer switching procedure is always DIFS initiated and it is managed using the MAC_CS_CF and the MAC_CSCF_END primitives (req/ind/cfm/res, see annex A, subclause A.1.2).

The reception of the MAC_CS_CF-req primitive at the MAC layer at the DIFS side starts the MAC layer switching procedure and causes the starting of the switching timer T217 (see subclause 8.1.2.5). A successful switching procedure shall be completed before this timer expires, otherwise the procedure fails and the MAC_CS_CF-cfm with the result parameter set to reject shall be sent to the DLC layer.

The parameters of the MAC_CS_CF-req primitive indicate:

- old LCN = LCNx;
- new LCN = LCNy;
- switching type = C_F to C_S.

The MAC layer procedure is based on the exchange of:

- a "attributes_T_request" message from DIFS followed by;
- a "attributes_T_confirm" message from DIPS followed by;
- a "other" message from DIPS.

The messages are carried in the tail of the A-field. The attributes_T_request and the attributes_T_confirm are Mt messages of the Advanced control set (ETS 300 175-3 [3], subclause 7.2.5.3.8).

The switching procedure is successfully completed when the DIFS after the positive acknowledgement of the `attributes_T_request`, receives the `attributes_T_confirm` error free. The completion of the procedure is reported to the DLC with the `MAC_CS_CF-cfm` primitive with the "result" parameter set to accept and the "status" set to stop.

If the first response of the DIPS side does not appear (A-CRC fails or no message received) in the TDMA half frame following the successful reception of the request message, the DIFS shall re-transmit the `attributes_T_request` up to N204 (see subclause 8.1.2.5) times within T217. If the `attributes_T_request` transmission fails N204 + 1 times or the T217 switching timer expires, the switching procedure ends and the `MAC_CS_CF-cfm` primitive is sent to the DLC with "result" parameter set to reject.

At the DIPS side the reception of the `attributes_T_request` message, indicates that the DIFS side has started the switching procedure. The MAC layer, after having acknowledged the request, sends to its DLC the `MAC_CS_CF-ind` primitive with "new LCN" set to LCNy and "switching type" set to C_F to C_S. The MAC layer then waits the `MAC_CS_CF-res` primitive to send the confirm to the DIFS side.

The reception of the `MAC_CS_CF-res` primitive at the DIPS side starts the MAC layer switching procedure and causes the starting of the switching timer T217 (see subclause 8.1.2.5). A successful switching procedure shall be completed before this timer expires. Otherwise the procedure fails and the `MAC_CSCF_END-ind` with the "result" parameter set to reject is sent to the DLC layer.

The switching procedure is successfully completed when the DIPS after the positive acknowledgement of the `attributes_T_confirm`, receives the other message error free. The completion of the procedure is reported to the DLC with the `MAC_CSCF_END-ind` primitive with the "result" parameter set to accept and the "status" set to stop.

If the first response of the DIFS side does not appear (A-CRC fails or no message received) in the TDMA half frame following the successful reception of the confirm message, the DIPS shall re-transmit the `attributes_T_confirm` up to N204 (see subclause 8.1.2.5) times within T217. If the `attributes_T_confirm` transmission fails N204 + 1 times or the T217 switching timer expires, the switching procedure ends and the `MAC_CSCF_END-ind` primitive is sent to the DLC with "result" set to reject.

At the DIFS side, after the positive completion of the switching procedure, the DLC releases the old LCNx, signalling data dedicated connection.

Procedure:

- 1) DIFS transmits "attributes_T_request" message with LCN bits = LCNy and C_F bit = C_F not required on the LCNy channel.
- 2) DIPS receives "attributes_T_request" error free (note 1) with LCN bits = LCNy an already existing connection and C_F bit = C_F not required; the MAC layer sends the `MAC_CS_CF-ind` primitive to the DLC.
- 3) If the DIPS is not ready to transmit "attributes_T_confirm" it sends immediately (note 2) "other" indicating the correct reception of the `attributes_T_request` message: Q2 set to 1. The "other" message shall be sent in the TDMA half frame before the successful reception of the request.

- 4) If the DIFS receives "other" error free:

then the DIFS waits the attributes_T_confirm.

Else if the DIFS does not receive the "other" message or receives it with $Q2 = 0$ (the attributes_T_request has not been correctly received by the DIPS side) it re-transmits "attributes_T_request" up to N204 times within T217.

- 5) If the DIPS receives the attributes_T_request error free, it sends immediately (note 2) "other" indicating the correct reception of the attributes_T_request message: $Q2$ set to 1. The DIPS, after receiving the MAC_CS_CF-res primitive sends "attributes_T_confirm" with LCN bits = LCNy and C_F bit = C_F not required.

- 6) If the DIFS receives "attributes_T_confirm" error free:

then sends immediately "other" indicating the correct reception of the confirm: $Q2 = 1$: the switching is correctly terminated and the MAC_CS_CF-cfm with "result" set to accept and "status" set to stop is sent to the DLC.

Else the DIFS waits until T217 expires.

- 7) If the DIPS does not receive "other" or receives it with $Q2 = 0$ (the attributes_T_confirm has not been correctly received by the DIFS side) it re-transmits "attributes_T_confirm" up to N204 times within T217.

Else the switching is correctly terminated and the MAC_CSCF_END-ind with "result" set to accept and "status" set to stop is sent to the DLC.

- 8) If the DIFS receives the attributes_T_confirm error free, it sends immediately (note 2) "other" indicating the correct reception of the attributes_T_confirm message: $Q2$ set to 1.

NOTE 1: receiving without error means A-field CRC hold and message recognized (message type decoded).

NOTE 2: immediately means in the TDMA half frame following the transmission of the attributes_T_request message (step 3 above) or the transmission of the attributes_T_confirm message (step 6 above).

MAC messages scenario:

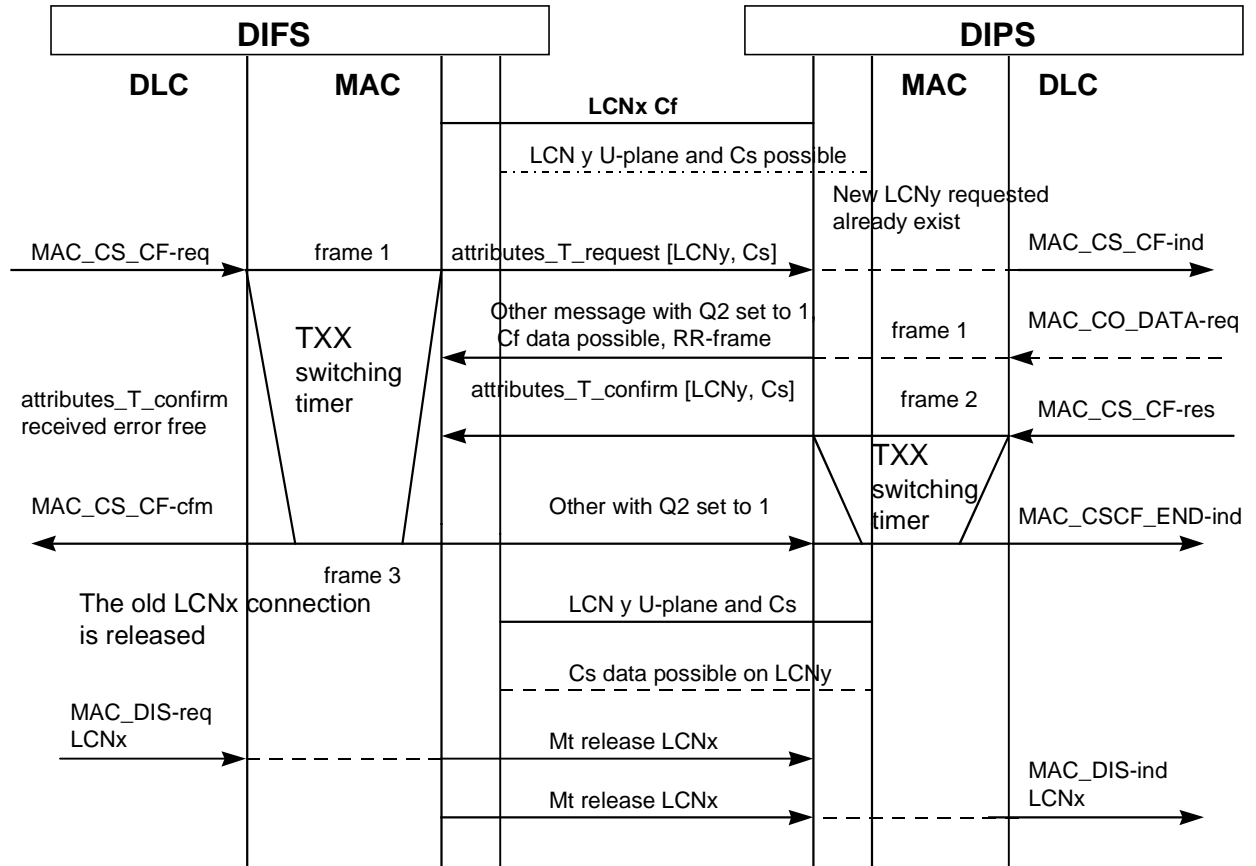

Figure 27: Dynamic switching C_F to C_S: MAC layer procedure

8.1.4.2 Dynamic switching C_S to C_F: DIPS initiated

The general procedure shall be performed as indicated in subclause 12.1. The following text together with the associated subclauses define the MAC layer requirements with regard to the general procedure.

Predicates:

The signalling link is on a U-plane connection LCNx numbered: B-field used for user data, B-channel and A-field used for signalling data, D-channel.

The DIPS detects that a C_F channel, B-field and so a new connection LCNy, is required. The switching is performed between an already existing connection LCNx, U-plane and Cs and a new connection that has to be established by the DIPS LCNy, C_F. The switching procedure is preceded by the setup of the new connection LCNy.

The LLME at the DIPS side, after the selection of the LCN value for the new signalling link connection as the lowest free value (as indicated in subclause 12.1), starts the connection setup procedure for the new connection LCNy.

The DLC at the DIPS side sends to its MAC the `MAC_CON-req` primitive with `LCN = LCNy` and C_F required. The MAC layer starts the bearer setup procedure using the B-field single bearer setup procedure. After the bearer setup has been successfully done, the positive result is reported to the DLC with the `MAC_CON-cfm` primitive.

At the DIFS side, after the bearer setup is successfully performed the MAC layer reports the positive result to the DLC with the `MAC_CON-ind` with `LCN = LCNy` and C_F required. The LLME and the DLC understand that this bearer is requested for the C_F channel by the DIPS side and starts the MAC layer switching procedure.

Procedure description:

Same as in subclause 8.1.4.1 with the following two exceptions:

- the "switching type" parameter in the MAC_CS_CF-req primitive (DIFS side) and in the MAC_CS_CF-ind primitive (DIPS side) is set to C_S to C_F , C_F required;
- the " C_F " bit in the attributes_T_request and in the attributes_T_confirm messages is set to C_F required;
- the old LCNx link shall not be released because is used for U-plane data.

Procedure:

Same as in subclause 8.1.4.1 with the following exception:

- the " C_F " bit in the attributes_T_request and in the attributes_T_confirm messages is set to C_F required.

MAC messages scenario:

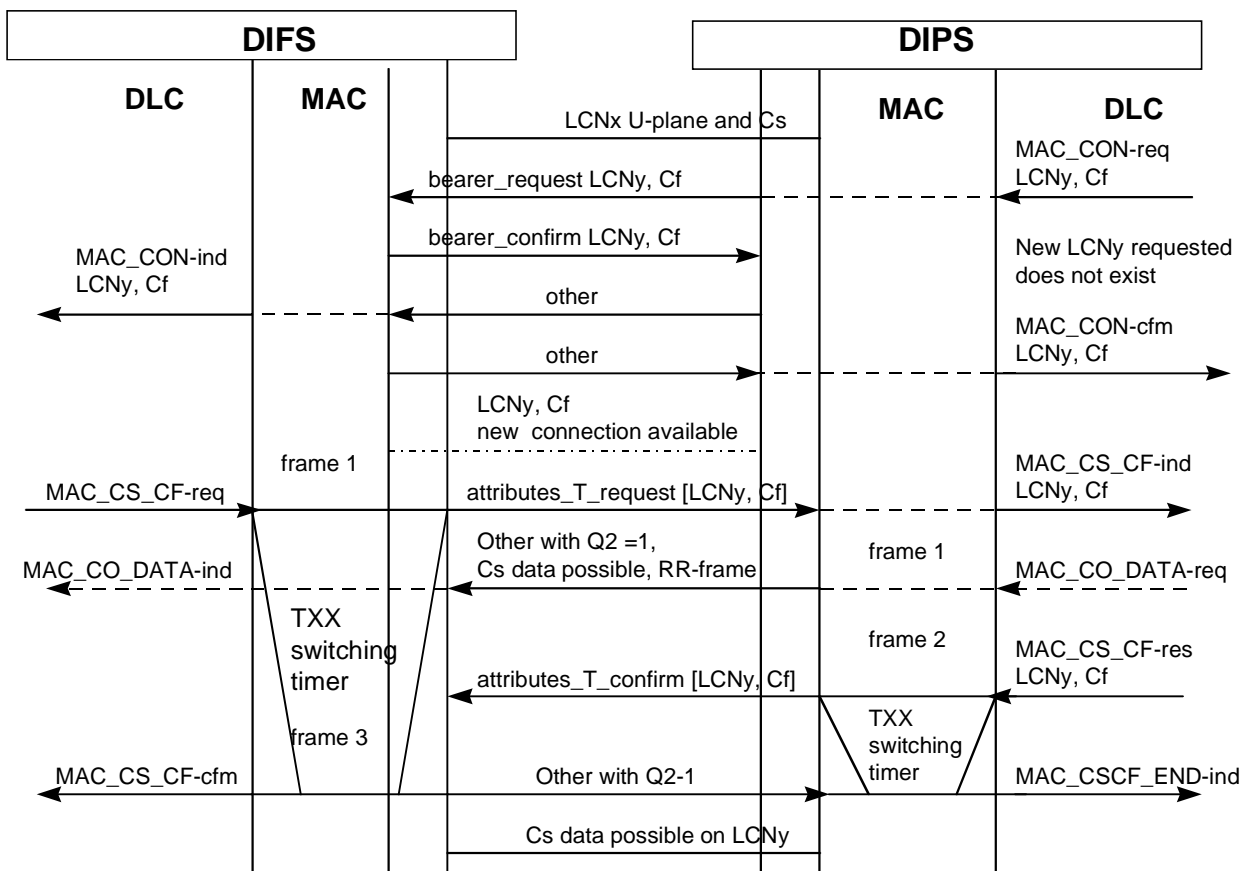

Figure 28: Dynamic switching C_S to C_F DIPS initiated: MAC layer procedure

8.1.4.3 Dynamic switching C_S to C_F : DIFS initiated

The general procedure shall be performed as indicated in subclause 12.1. The following text together with the associated subclauses define the MAC layer requirements with regard to the general procedure.

Predicates:

The signalling link is on a U-plane connection LCNx numbered: B-field used for user data, B-channel and A-field used for signalling data, D-channel.

The DIFS detects that a C_F channel, B-field and so a new connection LCNy, is required. The LLME at the DIFS side, after the selection of the LCN value for the new signalling link connection as the lowest free

value (as indicated in subclause 12.1), starts the first phase of the MAC layer switching procedure: the new connection has to be setup by the DIPS. The DIFS requires to the DIPS to setup the new signalling connection using an `attributes_T_request` message with `LCN = LCNy` indicating a new connection and `CF = CF` required indicating that the new connection is for the D-channel.

First Phase

Procedure description:

The first phase of the MAC layer switching procedure is always DIFS initiated and it is managed using the `MAC_CS_CF` and `MAC_CSCF_END` primitives (`req/ind/cfm/res`).

The reception of the `MAC_CS_CF-req` primitive at the DIFS side starts the MAC layer switching procedure and causes the starting of the switching timer T217. A successful switching procedure shall be completed before this timer expires, otherwise the procedure fails and the `MAC_CS_CF-cfm` with the result parameter set to reject shall be sent to the DLC layer.

The parameters of the `MAC_CS_CF-req` primitive indicate:

- old LCN = LCNx;
- new LCN = LCNy;
- switching type = C_S to C_F.

The MAC layer procedure is based on the exchange of:

- a `attributes_T_request` message from DIFS followed by;
- a `attributes_T_confirm` message from DIPS.

The messages are carried in the tail of the A-field. The `attributes_T_request` and the `attributes_T_confirm` are Mt messages of the Advanced control set (ETS 300 175-3 [3], subclause 7.2.5.3.8).

The first phase of the switching procedure is successfully completed when the DIFS, as the positive acknowledgement of the `attributes_T_request`, receives the `attributes_T_confirm` message error free. The completion of this phase is reported to the DLC with the `MAC_CS_CF-cfm` primitive with the "result" parameter set to accept and the "status" set to stop.

If the first response of the DIPS side does not appear (A-CRC fails or no message received) in the TDMA half frame following the successful reception of the request message the DIFS shall re-transmit the `attributes_T_request` up to N204 times within T217. If the `attributes_T_request` transmission fails N204 + 1 times or the T217 switching timer expires, the switching procedure ends and the `MAC_CS_CF-cfm` primitive is sent to the DLC with "result" parameter set to reject.

The MAC layer at the DIPS side, after the reception of the `attributes_T_request` error free, sends immediately the `attributes_T_confirm` message to the DIFS and sends to its DLC the `MAC_CS_CF-ind` with `LCN = LCNy` and `CF = CF` required.

The DLC at the DIPS side, after receiving the `MAC_CS_CF-ind` with an LCNy new, indicating the request of a new connection, starts the connection setup procedure for the new connection LCNy numbered required by the DIFS. The DLC then sends to its MAC the `MAC_CON-req` primitive with `LCN = LCNy` and `CF required`. The MAC layer starts the bearer setup procedure using the Advanced B-field single bearer setup procedure. After the bearer setup has been successfully done it is reported to the DLC with the `MAC_CON-cfm` primitive.

At the DIFS side, after the bearer setup is successfully performed the MAC layer reported it to the DLC with the `MAC_CON-ind` with `LCN = LCNy` and `CF required`. The LLME understands that this connection is the one just requested by the DIFS and that the second phase of the switching procedure has to be started. The LLME then starts the second phase of the MAC layer switching procedure.

Procedure:

First Phase:

- 1) DIFS transmits "attributes_T_request" message with LCN bits = LCN_y and C_F bit = C_F required on the LCN_y channel.
- 2) DIPS receives "attributes_T_request" error free (note 1) with LCN bits = LCN_y an already existing connection and C_F bit = C_F required; the MAC layer sends the MAC_CS_CF-ind primitive to the DLC.
- 3) The DIPS sends immediately (note 2) "attributes_T_confirm" indicating the correct reception of the attributes_T_request message: Q2 set to 1. The "attributes_T_confirm" message shall be sent in the TDMA half frame before the successful reception of the request.
- 4) If the DIFS receives "attributes_T_confirm" error free:

then the DIFS sends the MAC_CS_CF-cfm to the DLC and ends the first phase of the switching procedure.

Else if the DIFS does not receive the "attributes_T_confirm" message or receives it with Q2 = 0 (the attributes_T_request has not been correctly received by the DIPS side) it re-transmits "attributes_T_request" up to N204 times within T217.
- 5) If the DIPS receives the attributes_T_request error free, it sends immediately (note 2) "attributes_T_confirm" indication the correct reception of the attributes_T_request message: Q2 set to 1. The DIPS after receiving the MAC_CON-req with LCN = LCN_y and C_F = C_F required starts the advanced B-field single bearer setup procedure.
- 6) When the TBC reports bearer established the MAC sends to the DLC the MAC_CON-cfm.
- 7) When the TBC reports bearer established the MAC sends to the DLC the MAC_CON-ind.

NOTE 1: receiving without error means A-field CRC hold and message is recognized (message type decoded).

NOTE 2: immediately means in the TDMA half frame following the transmission of the attributes_T_request message (step 3 above) or the transmission of the attributes_T_confirm message (step 6 above).

Second phase:

Procedure description:

Same as in subclause 8.1.4.1 with the following exceptions:

- the "switching type" parameter in the MAC_CS_CF-req primitive (DIFS side) and in the MAC_CS_CF-res primitive (DIPS side) is set to C_S to C_F , C_F required;
- the " C_F " bit in the attributes_T_request and in the attributes_T_confirm messages is set to C_F required;
- the old LCNx link shall not be released because is used for U-plane data.

MAC messages scenario:

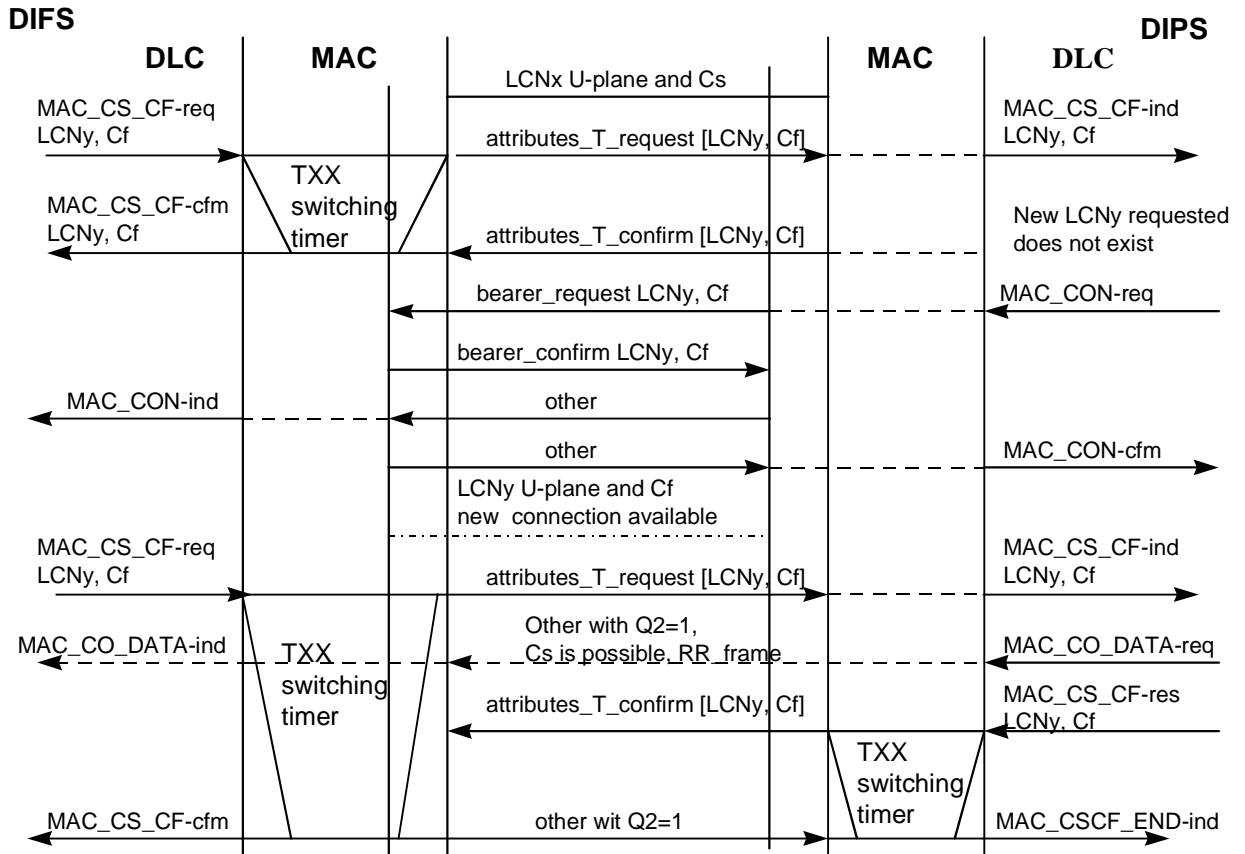

Figure 29: Dynamic switching C_S to C_F DIFS initiated: MAC layer procedure

8.1.4.4 Dynamic switching C_S x to C_S y: only DIFS initiated

The general procedure shall be performed as indicated in subclause 12.1. The following text together with the associated subclauses define the MAC layer requirements with regard to the general procedure.

Predicates:

The signalling link is on a U-plane connection LCNx numbered: B-field used for user data, B-channel and A-field used for signalling data, D-channel.

The DIFS detects that the LCNx U-plane is no longer required and has to be released. The LLME knows that there is an other U-plane connection LCNy numbered that could be used for the C-channel and starts the MAC layer switching procedure.

Procedure description:

Same as in subclause 8.1.4.1 with the following two exceptions:

- the "switching type" parameter in the MAC_CS_CF-req primitive (DIFS side) and in the MAC_CS_CF-res primitive (DIPS side) is set to C_S to C_S, C_F not required;
- the "C_F" bit in the attributes_T_request and in the attributes_T_confirm messages is set to C_F not required;
- the old LCNx link should be released by the DIFS at the end of the switching procedure.

Procedure:

Same as in subclause 8.1.4.1 with the following exception:

- the "C_F" bit in the attributes_T_request and in the attributes_T_confirm messages is set to C_F not required;

MAC messages scenario:

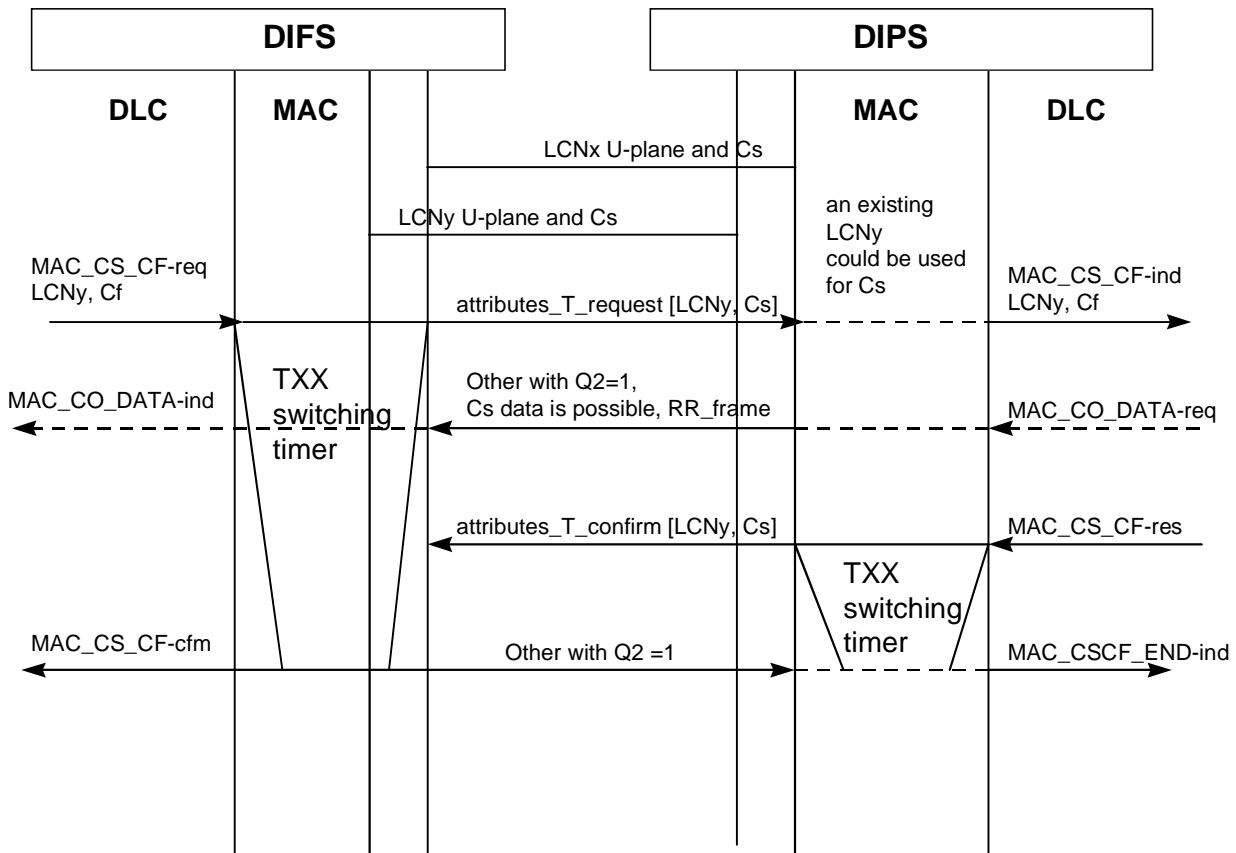

Figure 30: Dynamic switching C_S to C_S DIFS initiated: MAC layer procedure

8.1.4.5 Associated procedures

8.1.4.5.1 Associated procedures: DIFS side

T217 switching timer

Value 300 mS;
 Start The attributes_T_request is sent (reception of the MAC_CS_CF-req primitive);
 Stop The attributes_T_confirm is received (sending of the MAC_CS_CF-cfm).

N204 switching attempts counter

Value 5;
 Start The attributes_T_request is sent;
 Change A new attributes_T_request with the same switching procedure is sent;
 Clear The attributes_T_confirm is received.

8.1.4.5.2 Associated procedures: DIPS side

T217 switching timer

Value 300 mS;
 Start The attributes_T_confirm is sent (reception of the MAC_CS_CF-req primitive);
 Stop The other is received (sending of the MAC_CS_CF-cfm).

N204 switching attempts counter

Value %;
 Start The attributes_T_confirm is sent;
 Change A new attributes_T_confirm with the same switching procedure is sent;
 Clear The other is received.

8.2 MAC Layer U-plane procedures

8.2.1 U-plane connection setup procedure

If a U-plane service is required, then an additional MAC connection shall be set up. According to the requested service either an unprotected minimum delay full slot MAC connection together with the transparent LU1 DLC service, or an unprotected normal delay double slot MAC connection together with the protected LU7 DLC service, shall be used (see subclause 6.3.1).

The DIFS then shall request a new MAC connection to the DIPS using the DECT {CC-SETUP} message which shall contain all the MAC connection attributes indications and the LCN (ECN) connection identifier.

The DLC in the DIPS sends a MAC_CON-req to its MAC with all the parameters necessary to specify the required U-plane service.

Table 19: Values used within the MAC_CON-req primitive

Parameter	Information within the parameter	Normative action/comment
<<MCEI>>	MAC Connection Endpoint Identifier	
<<PMID>>	PMID	
<<CHO flag>>	Y/N	Y - if the connection is required for connection handover
<<C _F required>>	No	
<<Slot type>>	full slot, double slot	
<<Service type>>	I _n minimum delay, I _n normal delay	
<<connection type>>	Advanced	
<<ECN>>	{0,1,...,15}	

The MAC layer in the DIPS shall setup the required single bearer MAC connection (LCN (ECN)) as indicated in the MAC_CON.req primitive.

The MAC in the DIPS shall initiate the establishment of the required connection using the B-field advanced single bearer setup procedure PT initiated (see ETS 300 175-3 [3], subclause 10.5.1.3.1).

The DIPS and DIFS shall support the E/U MUX types E32 and E80 and types U32 and U80 defined in the ETS 300 175-3 [3], subclause 6.2.2.2.

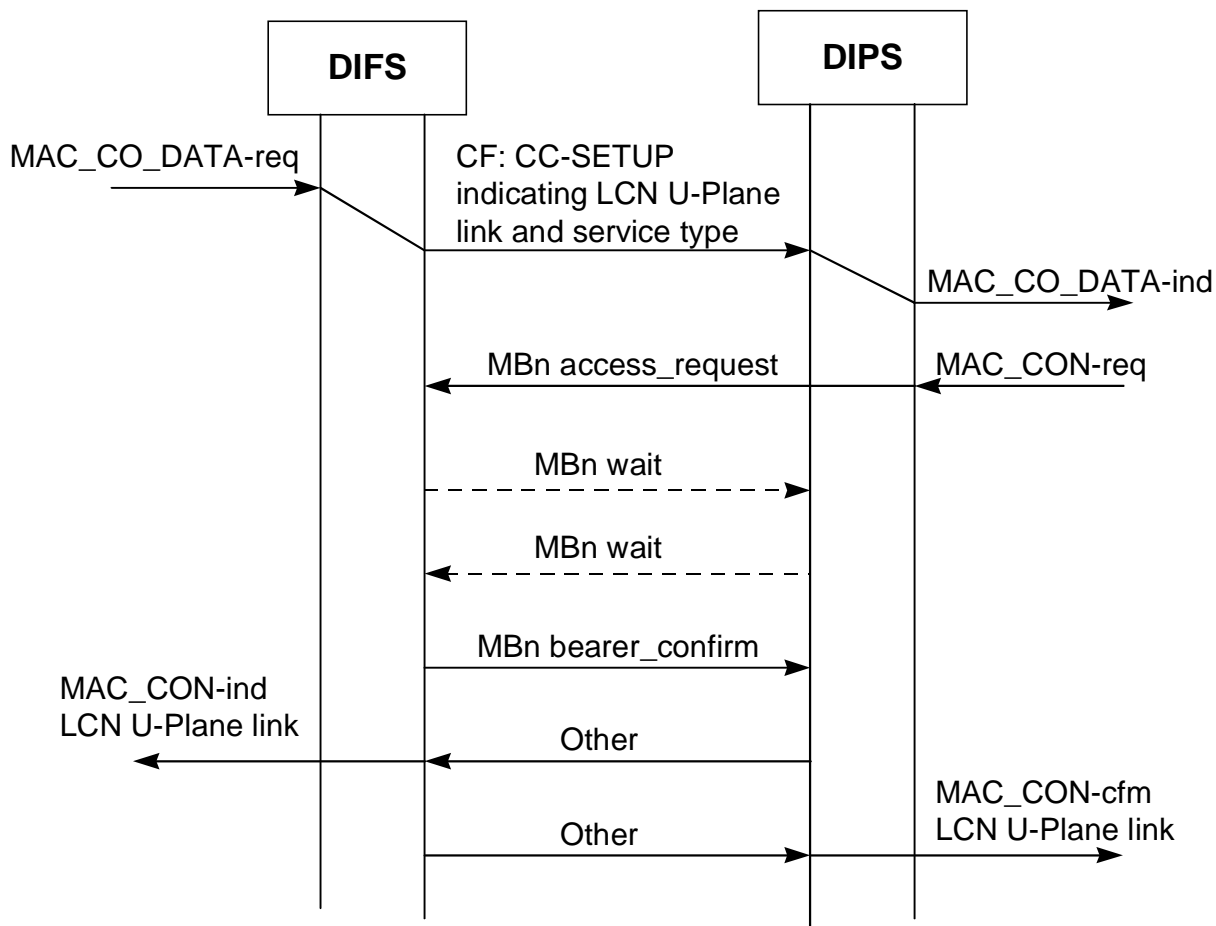

Figure 31: MAC layer U-plane connection setup scenario

8.2.1.1 MBn messages advanced connection control

The following fields as defined in subclause 7.3.3 of ETS 300 175-3 [3] in the MAC control (MBn) message shall be supported by the DIPS and the DIFS.

Table 20: Values used within MBn advanced connection control messages

MAC message	Field within the message	Standard values within the MAC message	Normative action/comment
<<MBn message>>			
	<MBn header>	X001	"Advanced connection control". X value depends on the B field contents
	<Command>	0	"Access_request"
		1	"Bearer_handover_request"
		4	"Connection_handover_request"
		2	"Bearer_confirm"
		5	"Wait"
	<FMID>	All	
	<PMID>	All	
	<ECN>	All	
	<LBN>	15	
	<up/down/sm/ss>	3	Symmetric single bearer connection
	<ser type>	0	"I _N voice"
		1	"I _N non voice"
	<max life>	0	
	<slot type>	0 / 2	Normal full slot / double slot
	<spr>	1111 B	

8.2.2 U-plane connection release procedure

The DLC in the DIPS sends a MAC_DIS-req primitive to its MAC with the MCEI of the U-plane connection to be released.

Table 21: Information used within the MAC_DIS-req primitive

Parameter	Information within the parameter	Normative action/comment
<<MCEI>>		

The unacknowledged bearer release procedure shall be used (see ETS 300 175-3 [3], subclause 10.7.2.1). The MBn-release message in the B-field shall be used.

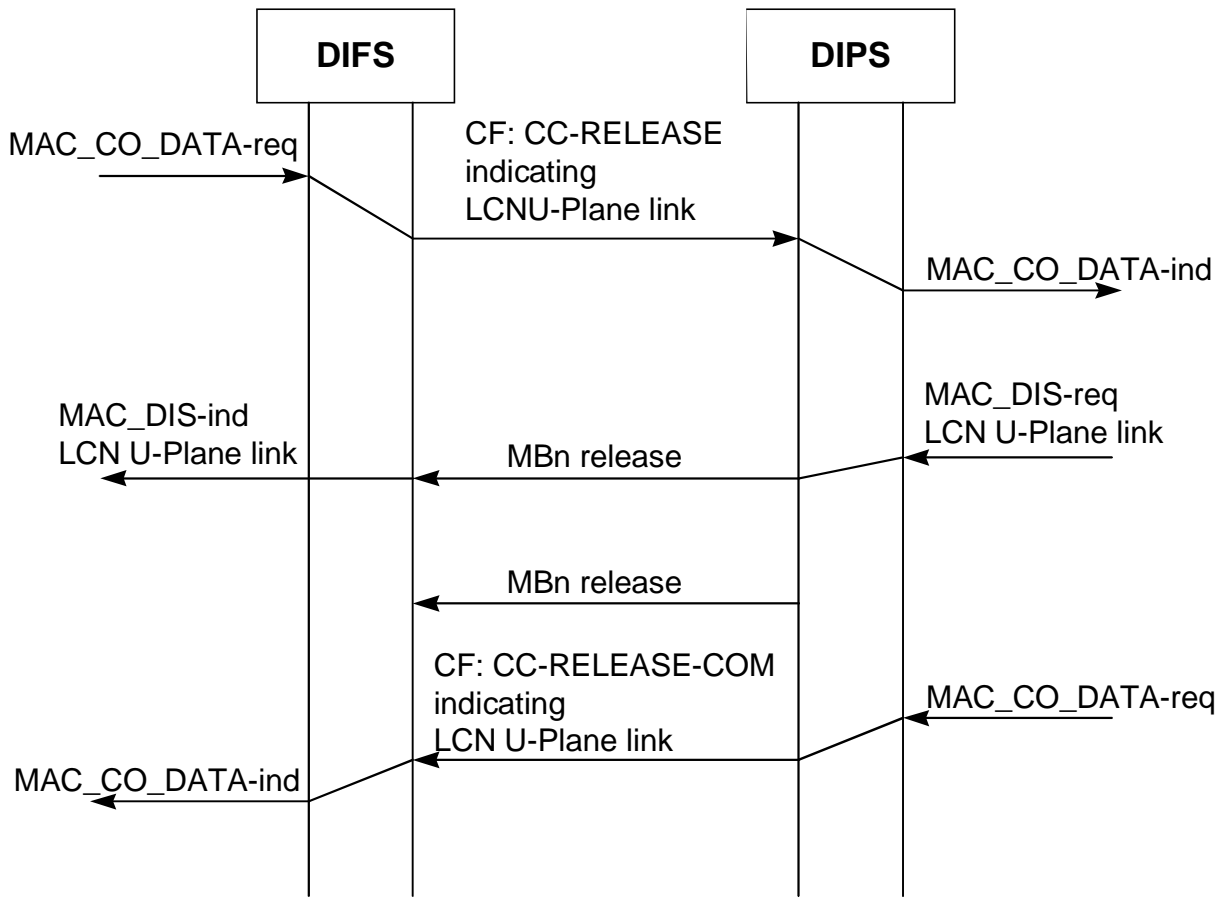

NOTE: The bearer is released only if it does not carry the signalling channel C_S otherwise the bearer has to be maintained or the signalling channel C_S has to be moved to another connection.

Figure 32: MAC layer U-plane link release scenario

8.2.2.1 MBn release message

The following fields as defined in subclause 7.3.3.10 of ETS 300 175-3 [3] in the MAC control (MBn) message shall be supported by the DIPS and the DIFS.

Table 22: Values used within Mbn release message

MAC message	Field within the message	Standard values within the MAC message	Normative action/comment
<<MBn message>>			
	<MBn header>	X001	"Advanced connection control". X value depends on the B field contents
	<Command>	15	"Release"
	<FMID>	All	
	<PMID>	All	
	<spr>	0000 B	
	<LBN>	All	
	<spare>	0000 1111 B	
	<reason>	All	

8.3 Signalling and U-plane connections: Timer T201 management

As indicated in the ETS 300 175-3 [3], subclause 11.5.1, a radioendpoint, DIFS or DIPS, shall release a bearer if it has not received the correct RFPI with a correct CRC on that bearer in the last T201 seconds. This means that when a bearer is established the T201 is started at both side, DIPS and DIFS, and if the correct RFPI is not received within this timer the bearer shall be released.

8.3.1 Timer T201

T201 time-out for bearer failure;
 Value see (ETS 300 175-3 [3], annex A);
 Start at the reception from the TBC of a bearer established indication;
 Stop every time a correct RFPI with a correct CRC is received over a bearer already established;
 Restart during the data transfer phase, at the reception of a correct RFPI with a correct CRC.

8.3.2 Timer T201 expiry

It may occur when a bearer is established but a correct RFPI has not been received within T201 seconds. The bearer is released using the unacknowledged bearer release procedure.

The MAC layer after having release the bearer sends to the DLC layer the MAC_DIS-ind with the reason parameter set to indicate RFPI handshake error.

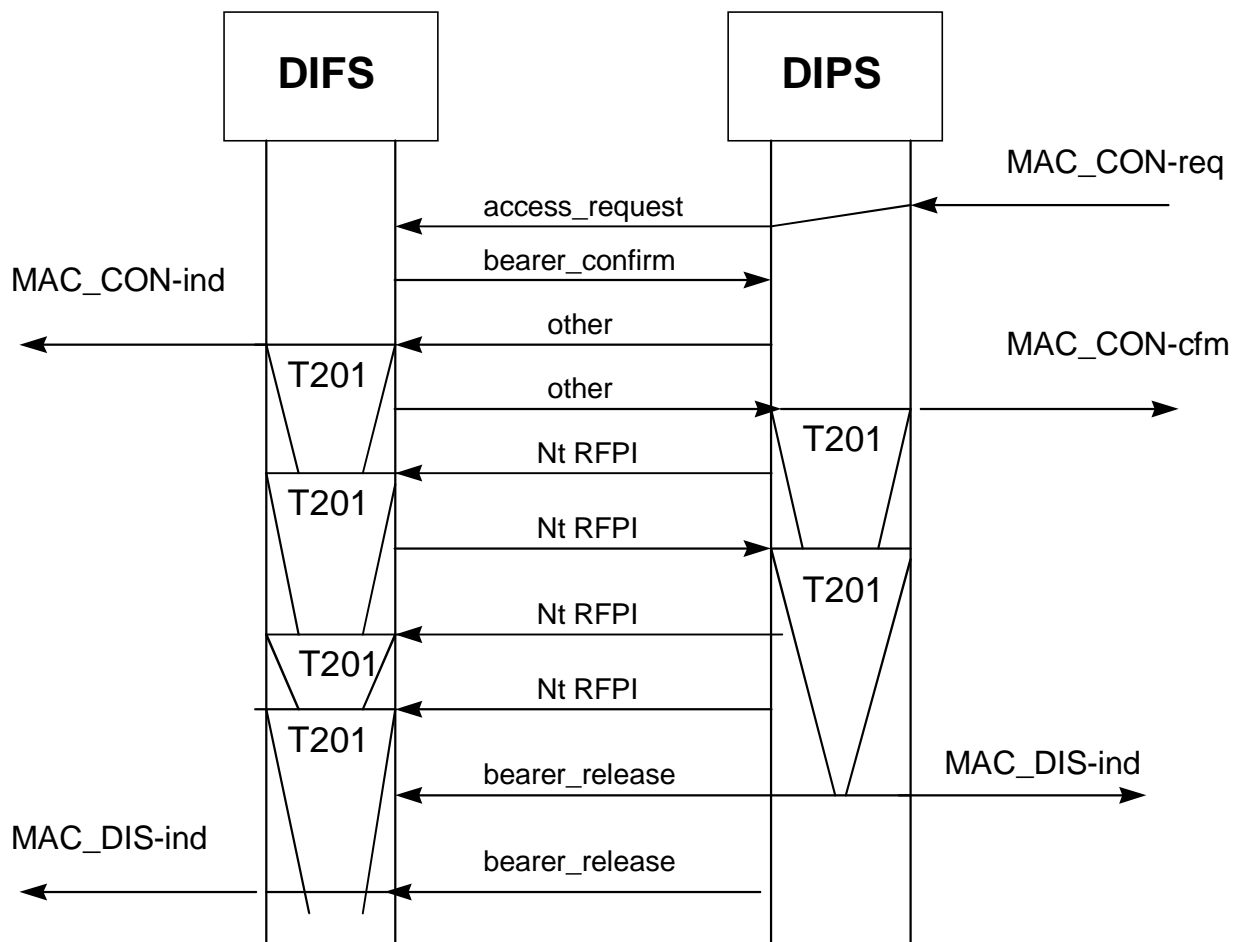

Figure 33: T201 expiry at the DIPS side

9 DLC layer procedures

This clause refers to elements specified in ETS 300 175-4 [4]. The DIFS and DIPS shall provide at least all of the elements stated below plus the mandatory elements of the ETS 300 174-4 [4].

9.1 DLC layer signalling procedures

9.1.1 Class B link establishment

The procedure shall be performed as defined in subclause 9.2.4.2 of ETS 300 175-4 [4]. The following text together with the associated subclauses define the mandatory requirements with regard to this ETS.

If Class B acknowledged transfer is requested but not supported by the receiving side the link shall be released by the DIPS.

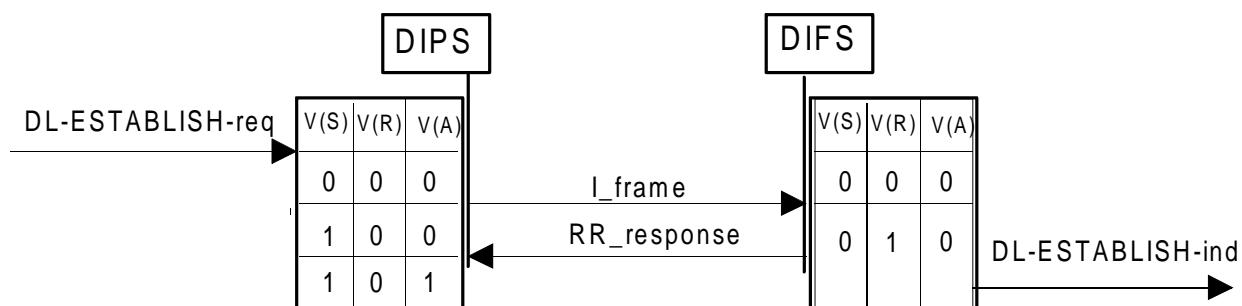

NOTE: During establishment of Class B multiple frame operation, the maximum number of outstanding I-frames (the window size) shall be set to "1" for both directions. Once in the ASM state, the maximum number of outstanding I-frames shall be set to the Class B value given in ETS 300 175-4 [4], subclause 7.5.2.2.

Figure 34: Class B link establishment

Table 23: Values used within the I-frame

Field	Parameter within the field	Standard values within the field/parameter	Normative action/comment
<<Address-field>>			
	<NLF>	1	New link
	<LLN>	2 ... 6	Class B operation
	<SAPI>	0	Connection oriented
	<C/R>	0	DIPS command
<<Control-field>>	<RES>	1	
	<N(R)>	0	N(R) = V(R)
	<P>	0	Ignore
<<Length-indicator-field>>	<N(S)>	0	N(S) = V(S)
		1..63	Higher layer info length.
	<M>	All	
<<Information field>>	<N>	1	No extended length field. If "0" the frame may be discarded
		All appropriate	Higher layer information.
<<Fill field>>		11110000B	Ignore. 0 to 7 such octets may be included in case for the C _F logical channel, as the frame length FLEN mod 8 = 0.
<<Checksum field1>>		All	The contents shall be calculated using two elements: LSIG see ETS 300 175-4 [4], subclause 10.3.1.
<<Checksum field2>>		All	See above.

Table 24: Values used within the {RR-Frame} S-format message

Field	Parameter within the field	Standard values within the field/parameter	Normative action/comment
<<Address-field>>			
	<NLF>	1	New link
	<LLN>	2 ... 6	Class B operation
	<SAPI>	0	Connection oriented
	<C/R>	0	DIFS response
	<RES>	1	
>>Control-field>>			
	<N(R)>	1	N(R) = V(R)
	<P/F>	0	
	<SS>	0	
	<***>	1	Constant
<<Length-indicator-field>>			
		0	No higher layer information
	<M>	0	
	<N>	1	No extended length field. If "0" the frame may be discarded
<<Fill field>>		11110000B	Ignore. 3 such octets shall be included in case for the C _F logical channel, as the frame length FLEN mod 8 = 0.
<<Checksum field1>>		All	
<<Checksum field2>>		All	

9.1.2 Associated procedure(s)

9.1.2.1 Timer <DL.02> management

<DL.02> Class B establishment timer;
 Value refer to ETS 300 175-4 [4], annex A;
 Start Class B link establishment I_frame is transmitted;
 Stop Class B accept or reject frame is received.

9.1.2.2 Re-transmission counter management

Refer to ETS 300 175-4 [4], subclauses 9.2.4.2 and 9.2.5.7.

Each LAPC entity shall maintain an internal re-transmission count variable determining the maximum number of re-transmissions of an I_frame. The default value shall be 3.

9.1.2.3 Multiple frame operation variables

Refer to ETS 300 175-4 [4], subclause 7.5.2.

For the DLC layer acknowledged transfer to be performed, the V(S), V(A), and V(R) operation variables together with their appropriate management shall be supported.

The allowed values of all state variables for a given class of operation shall always be defined by the modulus operation. For Class B operation, the modulus equals 8.

9.1.3 Class B acknowledged information transfer

The procedure shall be performed as defined in subclauses 9.2.5.3, 9.2.5.4, 9.2.5.5, 9.2.5.6, 9.2.3.7 of ETS 300 175-4 [4]. The following text together with the associated subclauses define the mandatory requirements with regard to this ETS.

The following cases, depending on the frame which conforms the reception of the frame-request, shall be supported:

- acknowledgement with an I_frame;
- acknowledgement with a RR_frame;
- acknowledgement with an RNR_frame;
- acknowledgement with an REJ_frame.

After receiving a correct I_frame the acknowledgement transfer should be performed immediately.

9.1.3.1 Acknowledgement with an I_frame

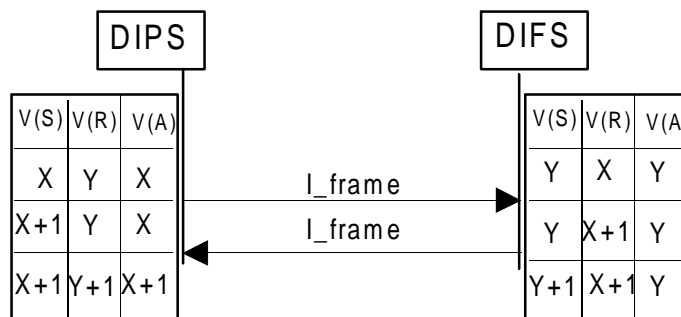

NOTE 1: During the calculation of the variable's values the assumptions has been made that: the I_frame sent by DIPS is not used for acknowledgement of previous received I_frames; and, both frames are not re-transmission.

NOTE 2: A Class B acknowledged information transfer procedure is considered as successful for the initiator when in case N(S) is sent and N(R) is received the next equation is valid: $(N(S) + 1) \text{ mod } 8 = N(R)$.

NOTE 3: The I_frame sent by the DIFS is assumed to be acknowledged as well (not indicated in figure 35).

NOTE 4: The case when DIFS initiates differs only in the notations.

NOTE 5: It is possible to acknowledge up to three I_frames with one I_frame.

Figure 35: Class B acknowledge information transfer by I_frame, DIPS initiated

Table 25: Values used within the I-Frame sent by the DIPS(DIFS)

Field	Parameter within the field	Standard values within the field/parameter	Normative action/comment
<<Address-field>>			
	<NLF>	0	
	<LLN>	2 ... 6	Class B operation
	<SAPI>	0	Connection oriented
	<C/R>	0	From DIPS
		1	From DIFS
	<RES>	1	
>>Control-field>>			
	<N(R)>	=V(R)	In I_frame transmitter
	<P>	0	Ignore
	<N(S)>	=V(S)	In I_frame transmitter
<<Length-indicator-field>>			
		1..63	Higher layer info length
	<M>	All	
	<N>	1	No extended length field. If "0" the frame may be discarded.
<<Information field>>		All relevant	Higher layer information.
<<Fill field>>		11110000B	Ignore. 0 to 7 such octets may be included in case for the C _F logical channel, 0 to 4 such octets may be included in case for the C _S logical channel.
<<Checksum field1>>		All	
<<Checksum field2>>		All	

9.1.3.2 Acknowledgement with a RR_frame

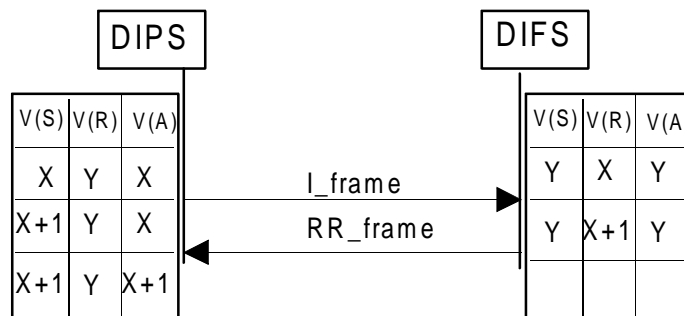

- NOTE 1: During the calculation of the variable's values an assumption has been made that the I_frame sent by DIPS is not used for acknowledgement of previous received I_frames and is not a re-transmission.
- NOTE 2: A Class B acknowledged information transfer procedure is considered as successful for the initiator when in case N(S) is sent and N(R) is received, the following equation is valid: $(N(S) + 1) \bmod 8 = N(R)$.
- NOTE 3: The case when DIFS initiates differs only in the notations.
- NOTE 4: It is possible to acknowledge up to three I_frames with one RR_frame.

Figure 36: Class B acknowledge information transfer by RR_frame

The values used within the {I-Frame} shall be the same as in Acknowledgement with an I_frame.

Table 26: Values used within the {RR-Frame} S-format message

Field	Parameter within the field	Standard values within the field/parameter	Normative action/comment
<<Address-field>>			
	<NLF>	0	
	<LLN>	2 ... 6	Class B operation
	<SAPI>	0	Connection oriented
	<C/R>	0	From DIFS
		1	From DIPS
	<RES>	1	
>>Control-field>>			
	<N(R)>	=V(R)	In RR-frame transmitter
	<P/F>	0	Ignore
	<SS>	0	RR-frame
	<***>	1	Constant
<<Length-indicator-field>>			
		0	No higher layer information
	<M>	0	
	<N>	1	No extended length field. If "0" the frame may be discarded.
<<Fill field>>		11110000B	Ignore. Three such octets shall be included in case for the C _F logical channel.
<<Checksum field1>>		All	
<<Checksum field2>>		All	

9.1.3.3 Acknowledgement with an RNR_frame

Table 27: Values used within the {RNR-Frame} S-format message

Field	Parameter within the field	Standard values within the field/parameter	Normative action/comment
<<Address-field>>			
	<NLF>	0	
	<LLN>	2 ... 6	Class B operation
	<SAPI>	0	Connection oriented
	<C/R>	0	From DIFS
		1	From DIPS
	<RES>	1	
>>Control-field>>			
	<N(R)>	=V(R)	In RNR-frame transmitter
	<P/F>	0	Ignore
	<SS>	0	RNR-frame
	<***>	1	Constant
<<Length-indicator-field>>			
		0	No higher layer information
	<M>	0	
	<N>	1	No extended length field. If "0" the frame may be discarded.
<<Fill field>>		11110000B	Ignore. Three such octets shall be included in case for the C _F logical channel.
<<Checksum field1>>		All	
<<Checksum field2>>		All	

9.1.3.4 Acknowledgement with an REJ_frame

Table 28: Values used within the {REJ-Frame} S-format message

Field	Parameter within the field	Standard values within the field/parameter	Normative action/comment
<<Address-field>>			
	<NLF>	0	
	<LLN>	2 ... 6	Class B operation
	<SAPI>	0	Connection oriented
	<C/R>	0	From DIFS
		1	From DIPS
	<RES>	1	
>>Control-field>>			
	<N(R)>	=V(R)	In REJ-frame transmitter
	<P/F>	0	Ignore
	<SS>	0	REJ-frame
	<***>	1	Constant
<<Length-indicator-field>>			
		0	No higher layer information
	<M>	0	
	<N>	1	No extended length field. If "0" the frame may be discarded.
<<Fill field>>		11110000B	Ignore. Three such octets shall be included in case for the C _F logical channel.
<<Checksum field1>>		All	
<<Checksum field2>>		All	

9.1.4 Segmentation of NWK layer message

If the NWK message is longer than 63 octets the DLC segmentation defined in ETS 300 175-4 [4], subclause 7.7.2 shall be used.

9.1.5 Associated procedure(s)

9.1.5.1 Timer <DL.04> management

DL.04> Re transmission timer;
 Value Refer to ETS 300 175-4 [4], annex A;
 Start A I_frame is transmitted;
 Stop On receipt of: an acknowledgement for that frame; a DL-RELEASE-req primitive indicating "abnormal"; a MAC-DIS-ind primitive.

9.1.5.2 Timer <DL.04> expiry

Refer to ETS 300 175-4 [4], subclause 9.2.5.7.

An errored or erroneous frame-acknowledgement shall be discarded and timer <DL.04> shall not be stopped.

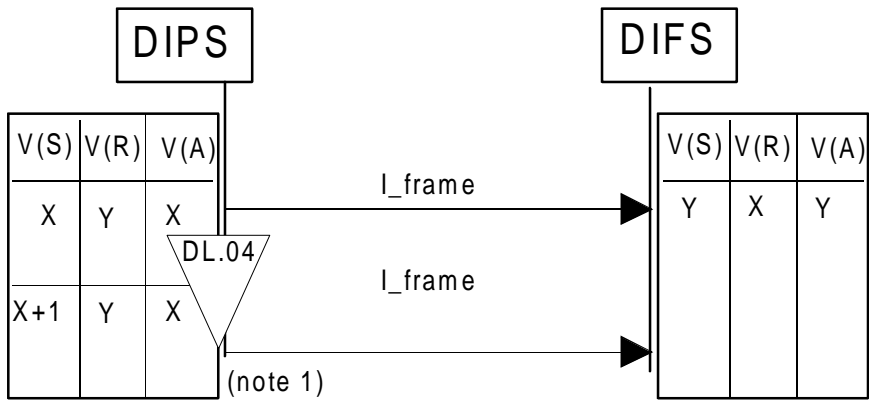

- NOTE 1: The I_frame will be re-transmitted only if the value of the re-transmission counter is less than N250.
- NOTE 2: During the calculation of the variable's values an assumption has been made that the I_frames sent are not used for acknowledgement of previous received I_frames and that the first one is not a re-transmission.
- NOTE 3: The case when DIFS initiates differs only in the notations.

Figure 37: Timer <DL.04> expiry

The values used within the {I-Frame} shall be the same as in Acknowledgement with an I_frame.

9.2 DLC Layer U-plane procedures

9.2.1 FU1 frame operation

The procedure shall be performed as defined in subclauses 12.1 and 12.2 of ETS 300 175-4 [4]. The following text together with the associated subclauses define the mandatory requirements with regard to this ETS.

The FU1 frame operation shall be used for U-plane within a full slot.

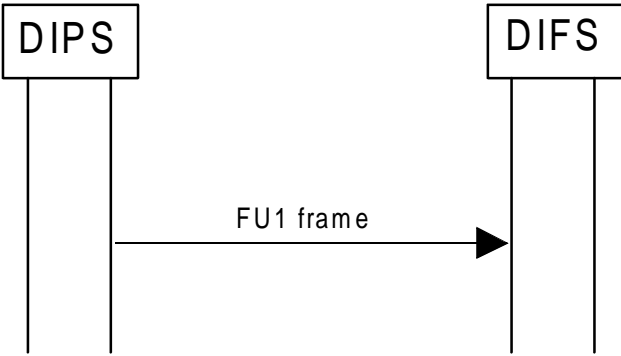

- NOTE: The case when DIFS initiates differs only in the notations.

Figure 38: Sending a FU1 frame

The length of a FU1 frame k = 40 octets (full slot).

One complete frame shall be submitted to/from MAC layer included in a MAC-CO-DATA-req(ind) primitive.

9.2.2 LU7 data bearer service

The procedure shall be performed as defined in annex E of ETS 300 175-4 [4]. The following text together with the associated subclauses define the mandatory requirements with regard to this ETS.

The LU-7 service is used to protect the transmission signal by an RS (255,249) code which may be used to correct up to 3 errors within a double slot connection. The generator polynomial to encode and decode the information has 6th degree:

$$p(X) = \prod_{i=0}^5 (X + \alpha^i)$$

Where α is a root of the binary primitive polynomial.

$$g(X) = X^8 + X^4 + X^3 + X^2 + 1$$

A data byte

$$(d_7, d_6, d_5, d_4, d_3, d_2, d_1, d_0)$$

is identified with the element

$$d_7\alpha^7 + d_6\alpha^6 + d_5\alpha^5 + d_4\alpha^4 + d_3\alpha^3 + d_2\alpha^2 + d_1\alpha^1 + d_0\alpha^0$$

in GF(256), the finite field with 256 elements.

9.2.3 LU8 service

This subclause defines the LU8 64 kbit/s speech and data service specified for the DECT radio interface.

9.2.3.1 Physical layer service

The used physical packet is the double slot (Pacjet P80).

9.2.3.2 MAC layer service

The duplex unprotected normal delay MAC service with the B-field multiplex U80a shall be used. A symmetric single bearer MAC connection shall be used.

9.2.3.3 DLC layer service

The Forward Error Control (FEC) defined in ETS 300 175-4 [4] shall be used.

The frame format FU8 used in the LU8 service is defined in figure 39.

2 bytes	80 bytes	10 bytes	2 bytes	6 bytes
spare bits	user data	spare bits	spare bits	RS Parity Symbol (FEC)

Figure 39: FU8 frame structure

This framing format is directly derived from the FU7 framing format removing the ARQ bytes and maintaining the FEC bytes.

The RS (255, 249) code provided by the FEC, may be used to correct up to 3 errors within a double slot connection and uses the generator polynomial defined in subclause 9.2.2.

If the error correction algorithm can not correct the errors in a double slot, the LU8 service should transmit the received user data to the IWU with a FEC error indication.

10 Network layer procedures

This clause refers to elements specified in ETS 300 175-4 [4]. The DIFS and DIPS shall provide at least all of the elements stated below plus the mandatory elements of the ETS 300 174-4 [4].

The interpretation of status columns in all tables in this ETS is as follows:

M	for Mandatory to support (provision mandatory, process mandatory);
O	for Optional to support (provision optional, process mandatory);
I	for out-of-scope (provision optional, process optional) not subject for testing;
C	for Conditional to support (process mandatory);
N/A	for Not-Applicable (in the given context the specification makes it impossible to use this capability).

Provision optional, process mandatory means that the indicated feature, service or procedure may be implemented, and if implemented, the feature, service or procedure shall be implemented as described in this ETS, and may be subject to testing.

NOTE: The used notation is based on the notation proposed in ISO/IEC 9646-7.

10.1 Network layer C-plane procedures

10.1.1 General overview

The NWK uses the following CC-Transactions for signalling-link management and B-channel/U-plane management.

Table 29: CC-Transactions

ISDN channel	Equivalent CC-Transaction	Purpose
D-channel	TI-Value = 6	Connectionless CC as described in ETS 300 175-5 [5], subclause. 7.3, is used for fast signalling without U-plane relation, e.g. transport of ISDN messages.
B-channel	TI-Value = 0 .. 5	Different CC-Transactions are used to establish the needed U-planes and connect them to the used B-channels.

10.1.2 Establishment of the signalling channel

To minimize time delay, the signalling link shall be established immediately after ISDN-L2 activation is detected or forwarding of broadcasted ISDN-L2 information is requested.

The CC entity (TI = 6) starts Signalling-Link establishment by sending a {IWU-INFO} message to its peer CC entity. This message is submitted to the LCE, the CC maintains its state (NULL) due to connectionless sending of the {IWU-INFO} message.

The LCE entity requests the DLC for Class B link-establishment to transport the {IWU-INFO} message to its peer entity.

10.1.2.1 Indirect DIFS initiated link establishment

The procedure shall be performed as defined in subclauses 14.2.1 and 14.2.3 of ETS 300 175-5 [5]. The following text together with the associated subclauses define the mandatory requirements with regard to this ETS.

DIFS and DIPS shall support short format for the {LCE-REQUEST-PAGE} message. When the DIFS request for a link establishment is successfully received by the intended DIPS, the DIPS shall initiate direct DIPS link establishment, see subclause 10.1.2.2.

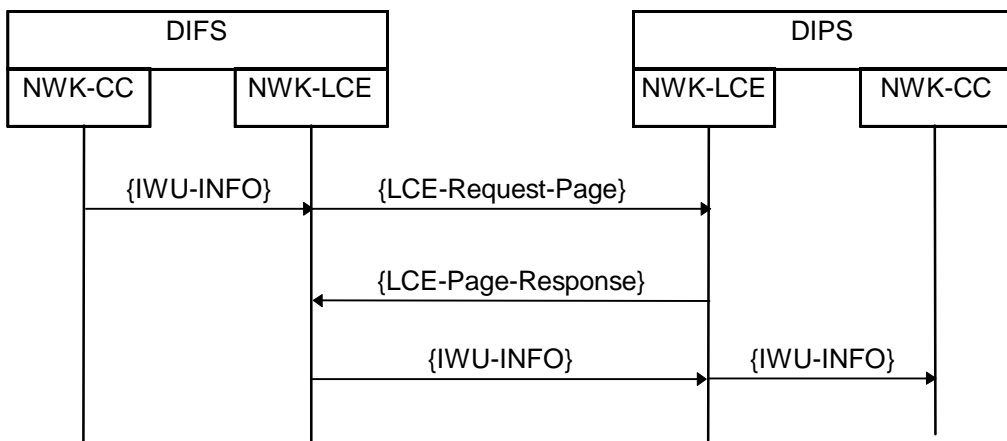

Figure 40: Indirect DIFS initiated link establishment

Table 30: Values used within the {LCE-REQUEST-PAGE} message

Information element	Field within the IE	Standard values within the field/IE	Status	Normative action/comment
<<LCE Header>>			M	
	<W>	All		
	<LCE-header>	0		Only C-plane is required.
<<Short address>>			M	
	<TPUI Address>	All		The lowest 16 bits from the actual TPUI value.

Table 31: Values used within {LCE-PAGE-RESPONSE} message

Information element	Field within the IE	Standard values within the field/IE	Status	Normative action/comment
<<Portable identity>>			M	Depends upon subscription records.
	<Type>	IPUI		
	<PUT>	All		
	<PUN>	All		
<<Fixed identity>>			M	Parameters depends upon subscription records.
	<Type>	32		PARK
	<Length indicator>	All		PLI + 1
	<ARC + ARD>	All		

10.1.2.2 Direct DIPS initiated link establishment

The procedure shall be performed as defined in subclauses 14.2.1 and 14.2.2 of ETS 300 175-5 [5]. The following text together with the associated subclauses define the mandatory requirements with regard to this ETS.

Direct DIPS initiated link establishment shall occur when the first service requested is detected by the LCE in the DIPS. In this procedure there is no peer-to-peer NWK layers message exchange except if the procedure is used in a indirect DIFS link establishment procedure, only NWK to DLC layer information exchange thereby invoking services from the lower layers.

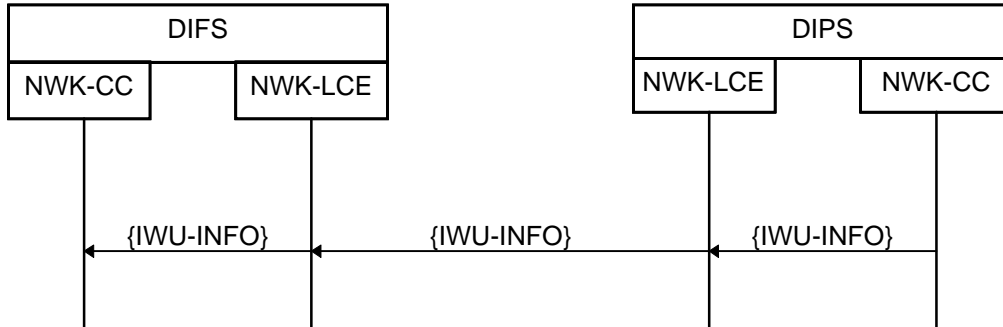

Figure 41: Direct DIPS initiated link establishment

Table 32: Values used within the DL-ESTABLISH-req primitive

Parameter	Information within the parameter	Status	Normative action/comment
<<DLEI>>		M	
	Data Link Endpoint Identifier		See ETS 300 175-4 [4], subclause 7.3.6.
<<Establish mode>>		M	
	Class B operation		
<<Message unit length>>	The length of the higher layer information	M	Included only when the field <<Message unit>> follows.
<<Message unit>>	Higher layer information	O	

The following data shall be inserted inside the first {IWU-INFO} message for proper routing:

Table 33: Values used within the first {IWU-INFO} message

Information element	Field within the IE	Standard values within the field/IE	Status	Normative action/comment
<<Portable identity>>			M	
	<Type>	0		IPUI
	<PUT>	All		Area dependent
	<PUN>	All		Area dependent
<<Repeat Indicator>>			O	Note 1
	<Repeat indicator>	1		Non Prioritized List of <IWU-TO-IWU> IE's
<<IWU-TO-IWU>>			O	As described in clause 14
	<S/R>	1		Transmission
	<Protocol Discriminator>	32		DECT/ISDN Intermediate System C-plane specific
	<ISDN L2 command>	All		
	DIPS CEI	All		
	ISDN L3 message	Appropriate L3 message or empty		

10.1.3 Transmitting of D-channel data

All D-channel signalling data shall be encapsulated in {IWU-INFO} messages. The {IWU-INFO} message shall use the CC-Transaction TI = 6 to be transmitted to the peer entity.

Long L2 messages, which cannot be transmitted inside one <IWU-TO-IWU> IE, shall be transmitted using two <IWU-TO-IWU> IEs with a <REPEAT-INDICATOR> preceding the first <IWU-TO-IWU> IE. ANNEX C shows some examples for segmentation of L2-messages.

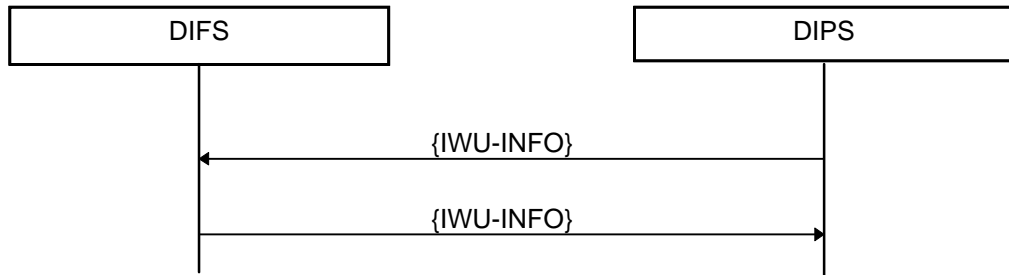

Figure 42: Transmitting of D-channel data

Table 34: Values used within the {IWU-INFO} message

Information element	Field within the IE	Standard values within the field/IE	Status	Normative action/comment
<<Repeat Indicator>>			O	
	<Repeat indicator>	1		Non Prioritized List of <IWU-TO-IWU> IE's
<<IWU-TO-IWU>>				As described in clause 14:"coding"
	<S/R>	1		Transmission
	<Protocol Discriminator>	32		DECT/ISDN Intermediate System C-plane specific
	<ISDN L2 command>	All		
	DIPS CEI	All		
	ISDN L3 message	Appropriate L3 message or empty		

10.2 Network Layer U-plane procedures

10.2.1 Establishment of DECT-U-planes and their switching to B-channels

The ISDN channels B0 and B1 will be switched separately, using the appropriate CC-Transactions.

The DIFS-IWU does a permanent ISDN-L3 monitoring, both of the Network messages as well as the TE messages which are transmitted transparently from the DIPS to the DIFS, therefore the connection of U-plane is always DIFS-initiated.

As soon as the ISDN <Bearer Capability> IE has been detected, appropriate MAC-Connections are established which support the needed Bearer-Service, and the appropriated U-planes are established. After the ISDN <Channel Id> has been detected and conditions for connection apply (see subclause 6.3.2), the established U-plane is connected to the appropriate B-channel.

All signalling should be done using the same signalling link, but using different Transaction Identifier.

10.2.1.1 Establishment of the DECT-U-planes

The procedure shall be performed as defined in subclauses 9.3.2, 9.3.2.1, 9.3.2.3 and 9.3.2.8 of ETS 300 175-5 [5]. The following text together with the associated subclauses define the mandatory requirements with regard to this ETS.

The message flow is as follows:

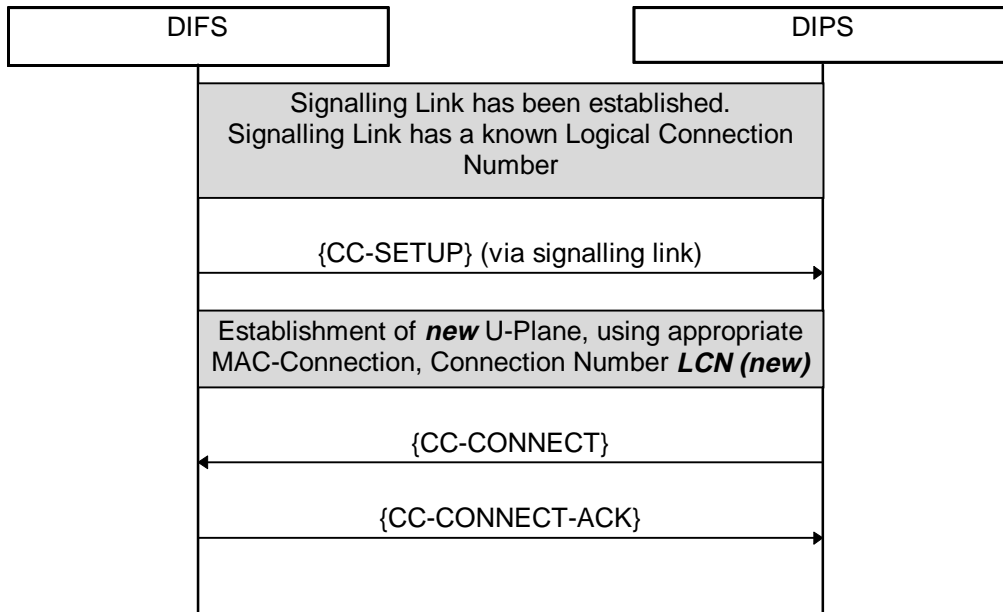

Figure 43: Establishment of the DECT-U-plane

Table 35: Values used within the {CC-SETUP} message

Information element	Field within the IE	Standard values within the field/IE	Status	Normative action/comment
<<Portable identity>>			M	
	<Type>	0		IPUI
	<PUT>	All		Area dependent
	<PUN>	All		Area dependent
<<Fixed Identity>>			M	
	<Type>	32		PARK
	<Length indicator>	All		PLI + 1
	<ARC + ARD>	All		Area dependent
<<Basic service>>			M	
	<Call class>	0		Normal call setup
	<Basic service>	7		DECT/ISDN Interworking Profile
<<Connection Attributes>>			M	
	<Symmetry>	1		Symmetric
	<Connection Identity>	LCN (new)		New Logical Connection number
	<Target Bearers P->F>	1		Octet 4 only
	<MAC Slot Size>	4,5		Depends on ISDN <Bearer capability>
	<MAC Service>	0,1		Octet 5 only
	<C _F channel attributes>	0		C _F never
	<MAC packet lifetime>	0		Octet 6 only
<<Call attributes>>			M	
	<Coding standard>	0		Octet 3 only: DECT standard coding
	<NWK layer attributes >	All		
	<C-plane class>	All		
	<C-plane routing>	All		
	<U-plane symmetry>	0		Octet 5 only: Symmetric
	<LU identification>	1,7		LU1, LU7
	<U-plane class>	0,1		Octet 0
<U-plane frame type>	1,7		FU1, FU7	

The structure of the messages CC_CONNECT and CC_CONNECT_ACK shall be taken from the ETS 300 175-5 [5].

10.2.1.2 Switching of U-plane to B-channel

As soon as the DIFS detects the ISDN <Channel Id> and conditions for connection apply, it shall switch the corresponding U-plane to the requested B-channel and advice the DIPS to connect the U-plane to the same B-channel on its side by sending an {IWU-INFO} message. The following text together with the associated subclauses define the mandatory requirements with regard to this ETS.

The {IWU-INFO} message shall use the same TI as the CC-SETUP Message, which established the U-plane Link.

The message flow is as follows:

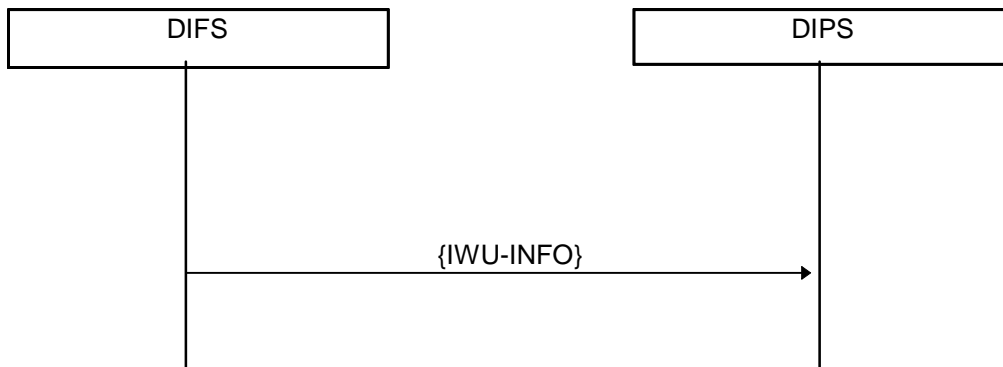

Figure 44: Switching of U-plane to B-channel

Table 36: Values used within the {IWU-INFO} message

Information element	Field within the IE	Standard values within the field/IE	Status	Normative action/comment
<<IWU-TO-IWU>>			M	As described in clause 14
	<S/R>	1		Transmission of message
	<Protocol Discriminator>	33		DECT/ISDN Intermediate System U-plane specific
	<B-channel command>	0		B-channel connect
	<B-channel Id>	1,2		Appropriate B-channel

10.2.2 Release procedures

When the U-plane is not longer needed, the associated U-planes shall be disconnected from the B-channels and they shall be released using the Normal Release procedure. For additional conditions for release of the U-plane see subclauses 6.7.1 and 6.7.3.

The procedure shall be performed as defined in subclause 9.5 of ETS 300 175-5 [5]. The following text together with the associated subclauses define the mandatory requirements with regard to this ETS.

The message flow is as follows:

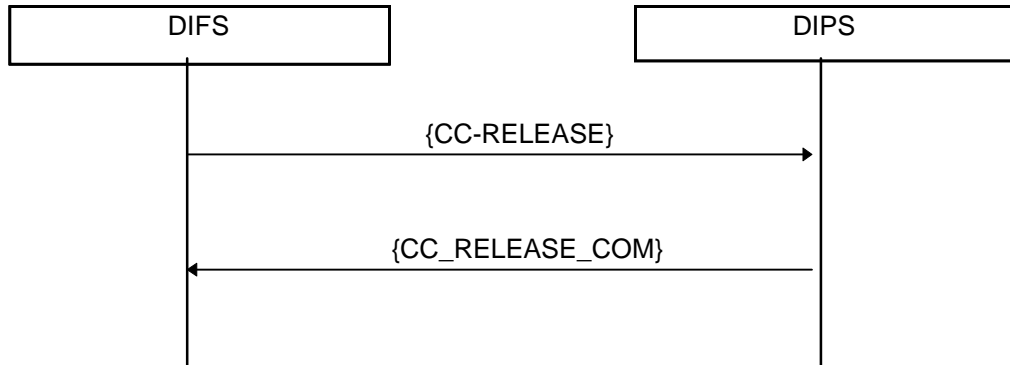

Figure 45: Release procedure

Table 37: Values used within the {CC-RELEASE} and {CC-RELEASE-COM} message

Information element	Field within the IE	Standard values within the field/IE	Status	Normative action/comment
<<IWU-TO-IWU>>			O	As described in clause 14
	<S/R>	1		Transmission of message
	<Protocol Discriminator>	33		DECT/ISDN Intermediate System U-plane specific
	<B-channel command>	1		B-channel disconnect
	<B-channel Id>	1,2		Appropriate B-channel

10.2.3 Switching of the B-channel

The DIFS may connect or disconnect, if necessary, the B-channels to/from already established U-planes and shall then advice the DIPS to connect/disconnect the same U-plane to the same B-channel on its side by sending the {IWU-INFO} message. The following text together with the associated subclauses define the mandatory requirements with regard to this ETS.

The {IWU-INFO} message shall use the same TI as the {CC-SETUP} message, which established the U-plane link.

The message flow is as follows:

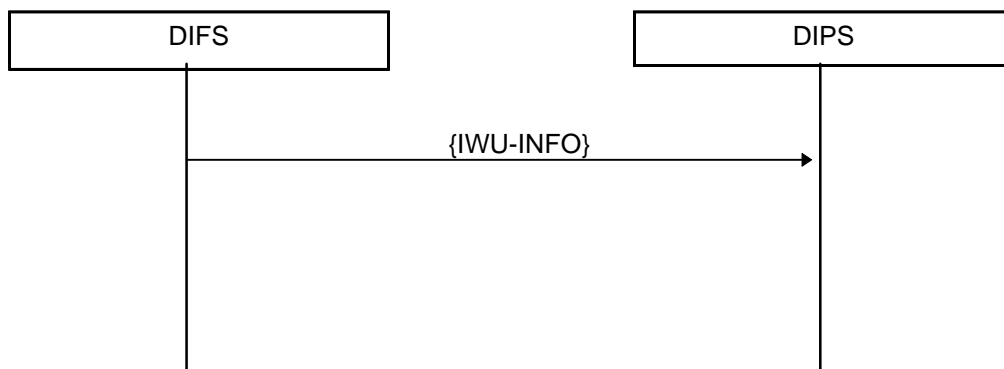

Figure 46: B-channel switching procedure

Table 38: Values used within the {IWU-INFO} message

Information element	Field within the IE	Standard values within the field/IE	Status	Normative action/comment
<<IWU-TO-IWU>>			M	As described in clause 14
	<S/R>	1		Transmission of message
	<Protocol Discriminator>	33		DECT/ISDN Intermediate System U-plane specific
	<B-channel command>	All		B-channel connect/disconnect
	<B-channel Id>	1,2		Appropriate B-channel

10.3 Mobility and security features

Table 39 defines some mobility management and security services.

Table 39 defines all the features which are mandatory, optional, and conditional under the provision of another protocol element, or out of the scope of this ETS, or in some context not-applicable according to the definition of the status column as defined in subclause 3.6 for the DIFS and DIPS.

Table 39: Mobility and security features status

Feature supported					
Item no.	Name of feature	GAP ref.	Status		
			DIPS	DIFS	
				R/B	P
N.9	Authentication of PP	4.1	M	O	M
N.11	Location registration	4.1	M	O	M
N.12	On air key allocation (note 1)	4.1	M	O	O
N.13	Identification of PP	4.1	M	O	O
N.17	Encryption activation FT initiated	4.1	M	O	M
N.18	Subscription registration procedure on-air	4.1	M	M	M
N.20	Terminate access rights FT initiated (note 1)	4.1	M	O	O
N.21	Partial release	4.1	O	O	O
N.26	Authentication of FT	4.1	O	O	O
N.27	Encryption activation PT initiated	4.1	O	O	O
N.28	Encryption deactivation FT initiated	4.1	O	O	O
N.29	Encryption deactivation PT initiated	4.1	O	O	O

NOTE 1: The entry of the AC and the PARK is out of scope.

For the provision of these features the procedure described in ETS 300 444 [15] shall be used with the additional requirements specified in the following subclause.

10.3.1 Mobility and security features: additional requirements

The DIPS and the DIFS shall use the signalling link to provide the MM features. If no signalling link is established at the moment of the invocation of the MM feature, the starting entity either DIFS or DIPS shall setup a signalling link as described in subclause 6.2.1.

For features N. 17, 27, 28, 29 related to the encryption features, the IE <<Connection Identity>> should be used in the {CIPHER_REQUEST} and {CIPHER_SUGGEST} messages to indicated to which connection the ciphering request shall be applied (signalling connection, U-plane connection or all the connection).

11 IWU procedures

11.1 Link association entity

11.1.1 General

Both IWU's in the DIFS and the DIPS contain a Link Association Entity (LAE). These provide for:

- stimulation of establishment and release of the D-channel;
- logical connection (association) of corresponding ISDN-L2-links at the network side and terminal side interface across the CI; and
- relaying of ISDN-L3 messages between these links.

Corresponding ISDN-L2 links are associated across the CI by a Link Association (LA). Mapping between addresses of the ISDN links and the addresses LA-CEI of the LA is described in subclause 6.4.

This clause describes the normal LA procedures and exceptional handling.

Before LA procedures can be used the C-plane-channel needs to be established if not yet existent.

11.1.2 Normal procedures.

11.1.2.1 Transfer of broadcasted L3 messages

If the DIFS-LAE receives in its IWU an ISDN-L3 message broadcasted by the network it forwards this to the NWL in a NWL data request primitive together with the L2 command "unnumbered info.transfer". The TEI value in the LA-CEI is 127dec. as in ETS 300 125 [22].

The DIPS-LAE receiving this message from its NWL in a NWL-data-indication primitive forwards the message inside its IWU using the LA-CEI.

When forwarding a broadcasted L-3 message the DIFS-LAE shall start and restart a timer TLAE1. The timer shall be stopped if a "L-2 estab.req" command is received from the DIPS-LAE.

If TLAE1 expires AND no LA is active the C-plane-channel shall be released. No action shall be taken if a LA is active at that time.

11.1.2.2 Transfer of L 3 messages on a point-to-point L 2 link

11.1.2.2.1 LA-establishment

This procedure is applied by the DIPS-LAE in a point-to-multipoint configuration and by both LAE's in a point-to-point configuration.

The LAE detects in its IWU that a LA needs to be established. It then forwards the L2 command "L2 estab.req" in a NWL-data-req. primitive to the NWL.

The comprised LA-CEI shall identify the corresponding ISDN-L2 link. The value of the LA-TEI shall be "0" in a point-to-point configuration.

The LAE receiving this L2-command in a NWL-data ind. primitive forwards this inside its IWU which upon this initiates the establishment of a corresponding ISDN-L2 link. The LAE then performs the mapping between the address of this link and the LA-CEI.

NOTE: ISDN-L2 re-establishment shall not cause LA establishment.

11.1.2.2.2 LA data transfer

A LAE receiving in its IWU L3 messages identified by an ISDN-L2 address maps this address to the corresponding LA-CEI.

It then forwards the message and the LA-CEI in a L2-command "numbered info. transfer" by a NWL data req. primitive to the underlying NWL. The peer LAE receives this information from its NWL in a NWL-data-ind. primitive, performs mapping to the corresponding ISDN-L2 address and forwards message and address inside its IWU.

11.1.2.2.3 LA release

A LA can be released by either side (DIFS or DIPS) if the IWU detects that the corresponding ISDN-L2 link has been released. The LAE then forwards a L2-command "L2 release req." with the corresponding LA-CEI across the CI to its peer entity. The receiving LAE informs its IWU which then initiates clearing of the corresponding L2 link.

The DIFS-LAE shall remove a released LA-CEI from the mapping list.

If no further LA is in use the release of the C-plane-channel shall also be initiated.

11.1.3 Exceptional handling and supervision

11.1.3.1 Rejection of ISDN-L2 establishment

If an ISDN-L2 link cannot be established towards the network by the DIFS-IWU or towards a TE by the DIPS-IWU the according LAE shall return a L2-command "release req." with the LA-CEI of the corresponding LA to its peer LAE. The IWU of the LAE receiving this command then initiates the release of the corresponding ISDN L 2 link.

11.1.3.2 Rejection of a transfer request at the C-plane-channel

NOTE: The actions described below shall also be taken if the MAC-layer carrying the C-plane-channel indicates a "missing resources condition" (see subclause 11.4).

If a L2-command or an U-plane related CC-message cannot be transferred via the CI the DLC-layer indicates this to the higher layers.

The C-plane-channel is then out of order because the MAC-layer carrying the C-plane-channel is released by the DLC layer.

The following actions shall then be taken:

DIFS:

- the IWU releases all L3 transactions with non-dummy call references by returning corresponding RELCOM messages to the network (cause = #47 resources unavailable, unspecified);
- then all L2 links are released towards the network.

DIPS:

- the IWU releases ISDN L1 towards the TE's.

DIFS and DIPS shall also perform internal clearing of U-plane resources concerned and reset global IWU states and U-NWL states.

11.1.3.3 CEI-problems

- a) L2-command "numbered info. transfer" cannot be mapped to an ISDN link because of an unidentified LA-CEI:

The LAE receiving such a command shall return a "release required" command containing the cause "error", the unidentified LA-CEI and the conflicted command type.

The IWU with the LAE receiving this "release required" with cause "error" shall initiate the release of the corresponding ISDN L-2 link if this can unambiguously be identified by their returned LA-CEI. Otherwise the procedures described in subclause 11.1.3.3, bullet c) shall apply.

- b) A L2-command "establish request" with a LA-CEI already in use. Such a command shall be ignored.
- c) A received L2-command "release req." with a LA-CEI already released e.g. not identified in the mapping tables. Such a command shall be ignored if it indicates the cause "normal".

If it indicates the cause "error" the receiving LAE releases the DLC and MAC connection for the C-plane-channel. DIFS and DIPS shall then follow the procedures as described in subclause 11.1.3.2.

11.1.3.4 L2-command coding problems

A received L2 command containing unidentified command coding shall be rejected towards the sending LAE by applying the procedure described in subclause 11.1.2.2.3 using the LA-CEI of the unidentified command. The "release required" shall indicate the cause "error".

11.1.4 Supervisory

11.1.4.1 Monitoring of ISDN-L2 links by the DIPS

The DIPS shall apply the data link layer monitor function as specified in ETS 300 125 [22], subclause 5.10. If monitoring fails for a specific link this is indicated to the DIPS-IWU.

The DIPS-LAE then releases the corresponding LA applying the procedure of subclause 11.1.2.2.3. with the cause value "normal".

11.1.5 LAE parameters

- TLAE1: 5 seconds.

11.2 Layer 3 monitoring

The DIFS shall analyse every ISDN L3 signalling message received from the network or a terminal via the DIPS. The following information shall be extracted from these messages in order to support ISDN connections by appropriate DECT channels:

- request, establishment and release of every call defined by a call reference;

NOTE: An ISDN link can support more than one call.

- management information for held and suspended calls;
- the bearer service requested and allocated to a call;
- connection and disconnection of the ISDN B-channels.

11.3 State machine

11.3.1 General overview

The DIFS-IWU at least contains such a minimum state machine (ASM) for each call identified by its call reference on a link address in order to support the ISDN call by according DECT system resources on an ISDN per call basis.

NOTE: The DIFS-IWU needs not to sustain an according state machine because it is fully under the control of the DIFS-IWU concerning ISDN L3 matters.

Other implementations are also possibly. All implementations shall however be compatible at the DECT-CI following the procedures as defined in this ETS.

11.3.2 IWU call states

The minimum IWU call states are defined such that they globally cover all network and user side call states of the ISDN L-3. The DIFS-IWU can thus keep track with the progress of a call, manage the DECT resources along with the progress of the call and can interact on the call by itself in exceptional cases.

The IWU call states:

IWU0: Idle: No call neither outgoing nor incoming is existent.

NOTE 1: The DIFS-IWU shall not interrupt forwarding of ISDN LE messages in this state.

NOTE 2: If the ASM returns to this state, the B-channel so far still connected shall be disconnected and the DECT U-plane so far not yet released or not hold for other calls shall be released.

IWU10: Active or activation pending: This state covers all ISDN call states for an incoming call once allocated to a TE and an outgoing call upon the initial call request.

IWU17: Call suspended: This state supports the ISDN supplementary service "Terminal Portability".

IWU6: Call present: This state covers the ISDN call states for an incoming call awaiting allocation to a TE.

11.3.3 State transitions

IWU0 -> IWU10:

- outgoing SETUP detected;
- timer TIWU1 is started and restarted upon the repetition of the SETUP message;
- TIWU1 is stopped upon a response to this SETUP received from the network.

IWU0 -> IWU6:

- incoming SETUP detected;
- a timer TIWU1 is started and restarted;
- in a point-to-multipoint configuration the ASM retains the L2 or LA addresses of all links on which positive responses are received from the TE's (e.g. SETUP-ACK, ALERT, CALL-PROC, CON). TIWU1 is stopped upon the reception of a first positive response;
- expiry: see IWU6 -> IWU0.

IWU17 -> IWU0:

- detection of a RESUME-REJ message received from the network, timer TIWU@ is stopped;
- expiry of timer TIWU2;
- conditions a, c, d, e as described for IWU10 -> IWU0.

IWU10 -> IWU0:

- a: detection of a RELCOM message received from the network or a TE on the L-2 link or LA which support the call;
- b: expiry of TIWU1;
- c: release indication for the LA-link and LA supporting the call;
- d: a timer TIWU3 shall be started upon the reception of a REL message with cause values other than #26 from the network or the TE. TIWU3 shall be stopped upon the reception of a responding RELCOM message. The state transition shall be performed upon the expiry of TIWU3;
- e: detection of a STATUS message from either side indicating the ISDN call state "null" for the sender of this message.

IWU6 -> IWU0:

- point-to-point configuration: Conditions a, b, c, d, e apply as described for the transition IWU10 -> IWU0;
- point-to-multipoint configuration:
 - a: expiry of TIWU1;
 - b: conditions a, c, d, e as described for the transition IWU10 -> IWU0 apply under the additional condition that at least one of these events has occurred on every link/LA which had before carried a positive response.

NOTE: RELCOM messages detected as first responses from the TE's shall be ignored.

The transition to the state IWU0 can also be stimulated by the ISDN restart procedure in a point-to-point configuration:

- if a RESTART message is received from either side the indicated channels shall be disconnected, the U-planes allocated to these channels be released and the state machines for these calls which are using these channels be returned to IWU0;
- alternatively the above actions can be performed upon the reception of the responding RESTART-ACK message or upon the expiry of TIWU4. TIWU4 is started upon the RESTART message and stopped upon the RESTART-ACK message.

IWU6 -> IWU10:

upon detection of the CONNECT-ACK message received from the network.

IWU10 -> IWU 17:

detection of SUSPEND-ACK received from the network. This event starts a timer TIWU2 (3,5 min).

IWU17 -> IWU10:

detection of RESUME-ACK received from the network.

11.3.4 Parameters

Timer values:

- TIWU1: according ISDN L-3 timers T303 (4 seconds), T312 (T303 + 2 seconds = 6 seconds);
- TIWU2: according ISDN L-3 timer T317 (3,5 min);
- TIWU3: 8 seconds;- TIWU4: 2 minutes.

11.4 Actions upon missing DECT resources

11.4.1 General

This clause describes the procedures to be applied at the ISDN interfaces and the CI in the case of "missing DECT channel resources" (missing resources condition).

Definition of the missing resources condition:

- DECT bearers for the support of the C-plane or U-plane cannot be established or maintained after unsuccessful re-attempts and handover.

If a C_F is required for the support of the D-channel while this is carried by a C_S and a C_F is not available the following rule shall apply:

- if the DIFS or DIPS are able to identify the specific ISDN function requiring the C_F and this function can explicitly be rejected, this function may be rejected and the C-plane-channel be retained in the C_S ;
- otherwise this case shall be considered "C-plane-channel lost".

11.4.2 Actions of the DIFS

11.4.2.1 The C-plane-channel cannot be established

11.4.2.1.1 Point-to-point configuration

Release of the L2 link towards the network.

11.4.2.1.2 Point-to-multipoint configuration

Upon the reception of broadcasted messages with non-dummy call references: no action.

11.4.2.2 The C-plane-channel is lost

The actions described in subclause 11.1.3.2 shall be performed.

11.4.2.3 An U-plane-channel cannot be established

11.4.2.3.1 Point-to-point configuration

The DIFS shall return a RELCOM message (cause = #47) to the network or the TE (via the DIPS) and also forward this message to the other side (DIPS or network). The SETUP message is forwarded independently from the outcome of U-plane-channel setup.

11.4.2.3.2 Point-to-multipoint configuration

The DIFS-IWU shall forward the SETUP message not awaiting the establishment of the U-plane-channel before. The procedures of subclause 11.4.2.4 for the case "U-plane-channel lost" shall then be followed.

11.4.2.4 An U-plane-channel is lost

11.4.2.4.1 Point-to-point configuration and outgoing call in a point-to-multipoint configuration

The DIFS-IWU releases all concerned calls using the corrupted U-plane by sending RELCOM messages (cause = #47) to the network and the DIPS.

NOTE: This also covers calls held on the lost U-plane in multi-point configurations.

11.4.2.4.2 Point-to-multipoint configuration, incoming call

The DIFS-IWU shall provide means for L-3- release towards the network and the TE's of call(s) being active or transactions on call's still in progress which use the corrupted U-plane. The means are open for implementations.

NOTE: This can for example be achieved by explicit release by a RELCOM message towards network and TE's upon each positive response from a TE (e.g. ALERT, CON, CALL-PROC, SETUP-ACK).

No action is required for the case that no positive response has been received from the TE's.

11.4.3 Actions of the DIPS

11.4.3.1 The C-plane-channel cannot be established or is lost

See subclause 11.1.3.2

11.4.3.2 An U-plane-channel cannot be established.

The CC-SETUP message is rejected by a CC-RELCOM message.

11.4.3.3 An U-plane-channel is lost

The U-NWL concerned is released towards the DIFS by sending a CC-RELCOM message to the DIFS.

11.5 Other interworking functions

11.5.1 Call hold

If support of Call Hold is supported the following shall apply:

If an ISDN call is put on hold the DECT system shall retain the U-plane which is used by that call. The U-plane shall then be re-used for follow-on actions upon the CEI carrying the held call. If the bearer capabilities of the retained U-plane do not match the requirements of follow-on actions, the procedures of subclauses 12.2.3 and 12.2.4 shall be used in order to change the service. While a call supported by a double slotted U-plane is on hold a double slot U-plane type shall be retained and used for follow-on actions.

If the service is not supported, the DECT system rejects a HOLD message returning a HOLD-REJ message containing an appropriate cause (e.g. #69, requested facility not implemented). The HOLD message shall be discarded.

11.5.2 Fall back procedure

If the DECT system supports the function, it shall keep track for incoming and outgoing calls with the outcome of the ISDN based bearer capability selection. The outcome of the procedure becomes evident while call establishment is going on. Nevertheless an appropriate DECT U-plane and the allocated B-channel shall be switched for an outgoing call to support the reception of inband tones and announcements.

A DECT system not supporting this function shall follow the procedures of ITU-T Recommendation Q.931 [26], paragraph 5.11.3 and 5.12.3.

11.5.3 Terminal portability

The support of this service is mandatory for the DECT system. The DECT system shall retain the allocated U-plane for the time of call suspension.

12 Dynamic switching procedures

12.1 Dynamic switching procedures between DECT signalling channels

Depending on the D- and B-ISDN channel requirements there may exist up to three MAC-connections between the DIFS and DIPS. The common DLC layer above these MAC-connections shall only use one selected C-channel to transport the higher layer signalling. The following procedure describes how to move the higher signalling from one to an other C-channel on a different MAC-connection.

The LLME in the DIFS handles the switching between the different C-channels and is always initiator from the switching procedure. The DIFS knows always which MAC connection is suitable for C-plane transmission.

Exception:

The DIPS has also the possibility to inform the DIFS that a switch to the C_F-channel is necessary. This shall be performed by establishment of a bearer with the reserved LCN-value for the C_F signalling bearer refer to subclause 12.1.6.

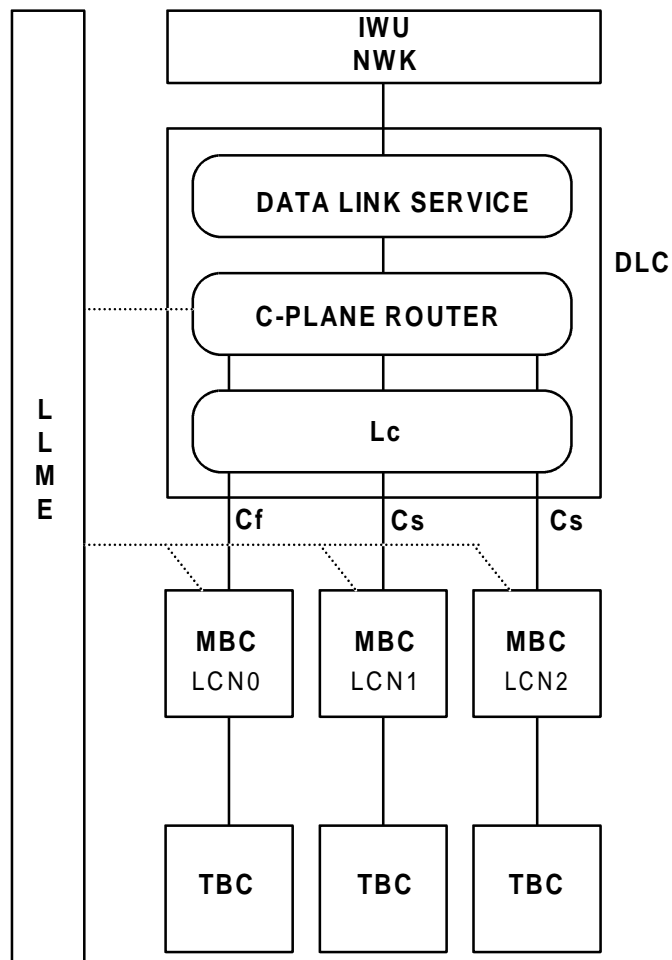

LLME: Lower Layer Management Entity

MBC: Multi-Bearer Control

Figure 47: C-plane model

12.1.1 First establishment of signalling bearer (C_F)

The first established MAC-connection between DIFS and DIPS shall be used for the C_F -channel.

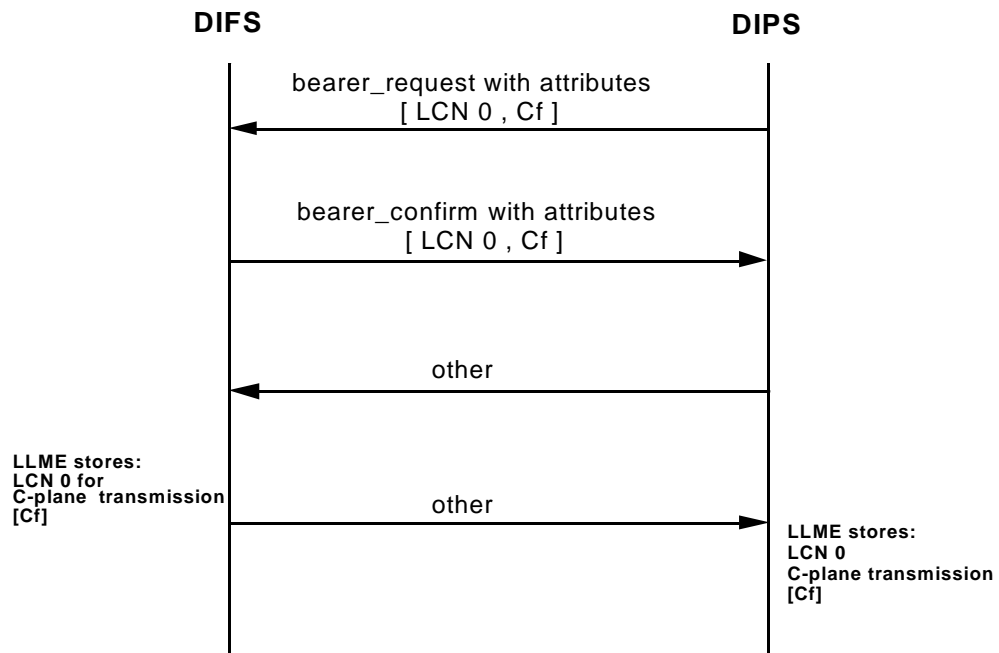

Figure 48: Establishment of signalling bearer

An additional bearer for U-plane transmission [e.g. LCN 1] can be setup via the signalling bearer.

12.1.2 General description of the C-plane switching procedure

Switching from C_x - to C_y - channel where C_x and C_y could be C_S and / or C_F.

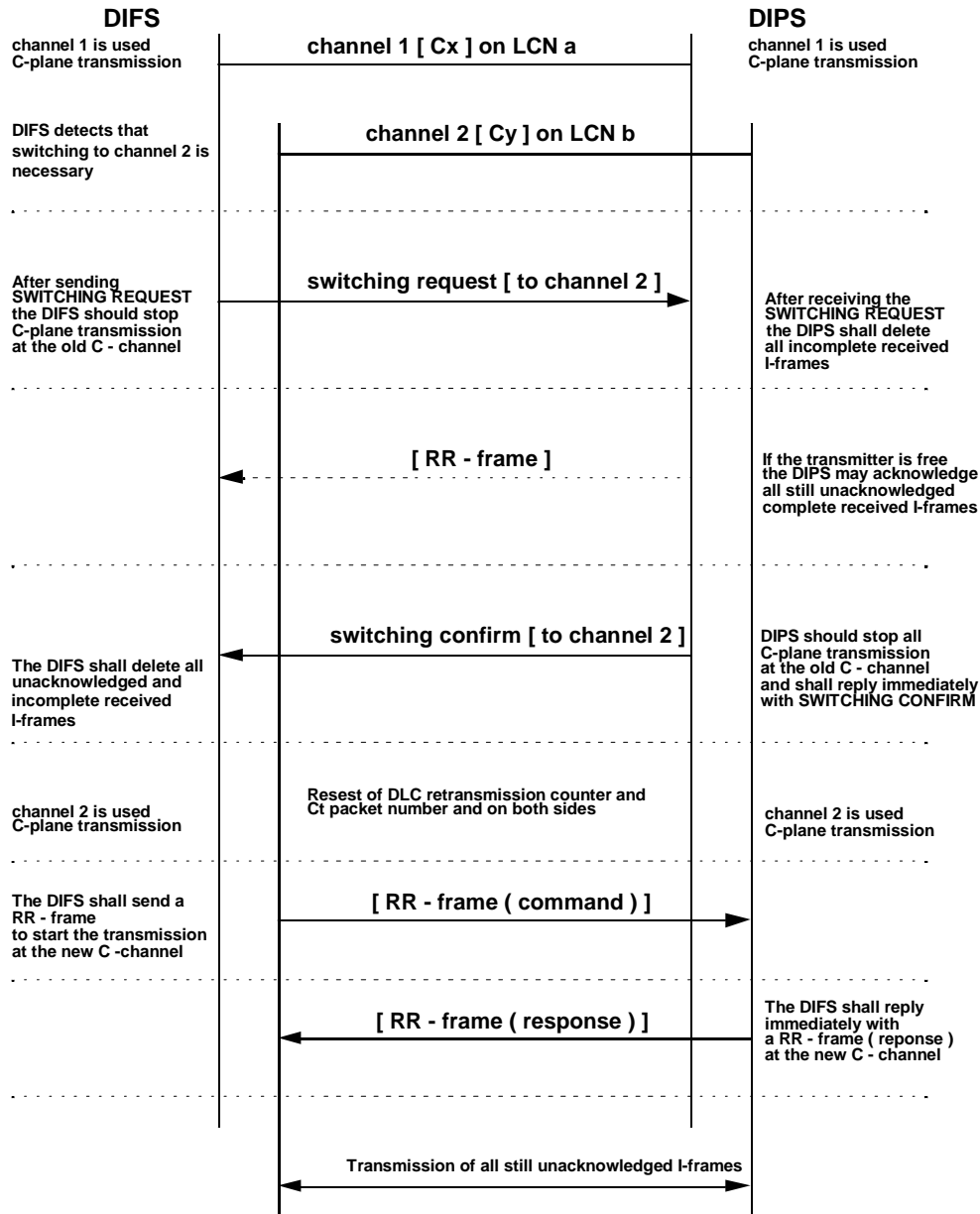

Figure 49: C-plane switching procedure principles

For the SWITCHING-REQ and -CFM the Mt-messages ATTRIBUTE_T_REQ and -T_CFM messages shall be used.

12.1.3 Switching from C_F to C_S channel, only DIFS initiated

Starting position:

Two bearers are established between DIFS and DIPS:

- 1) LCN 0 C_F signalling bearer;
- 2) LCN 1 U-plane connection [C_S signalling possible].

The LLME on both sides have stored, that the LCN 0 [C_F] shall be used for C-plane transmission. The DIFS detects that the C_F channel is not further necessary.

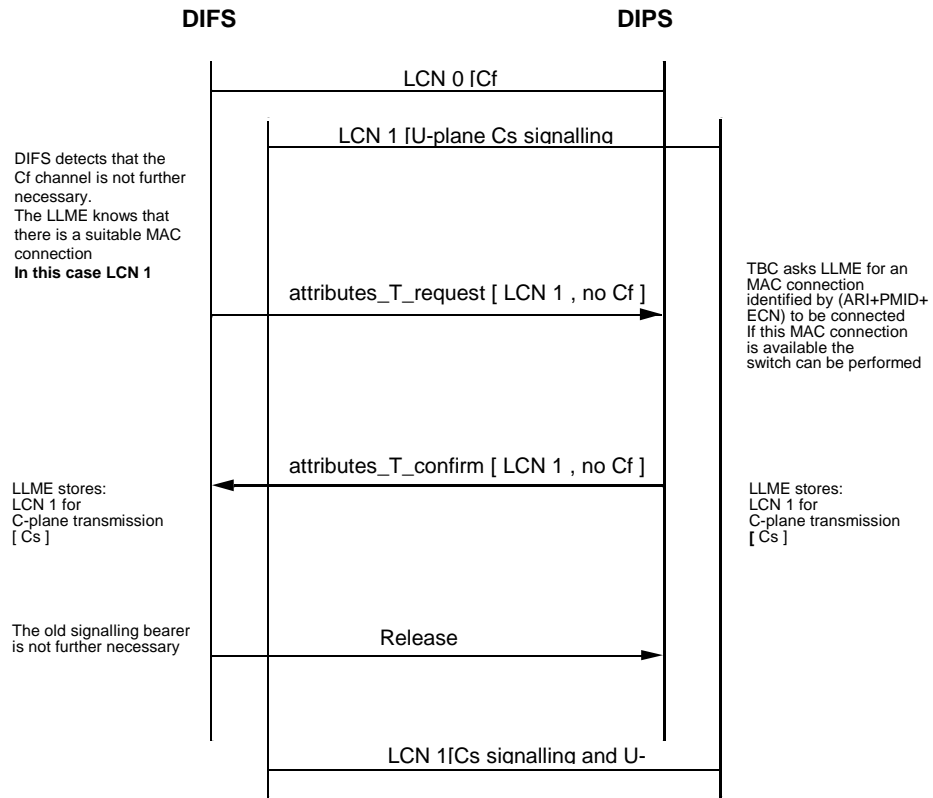

NOTE: The DLC RR_frames are not included in the diagram.

Figure 50: C-plane switching from C_F to C_S

12.1.4 Switching between C_S and C_S channel, only DIFS initiated

Starting position:

Two bearers are established between DIFS and DIPS:

- 1) LCN 1 U-plane connection [C_S signalling];
- 2) LCN 2 U-plane connection [C_S signalling possible].

The LLME on both sides have stored, that the LCN 1 [C_S] shall be used for C-plane transmission. This bearer shall be released.

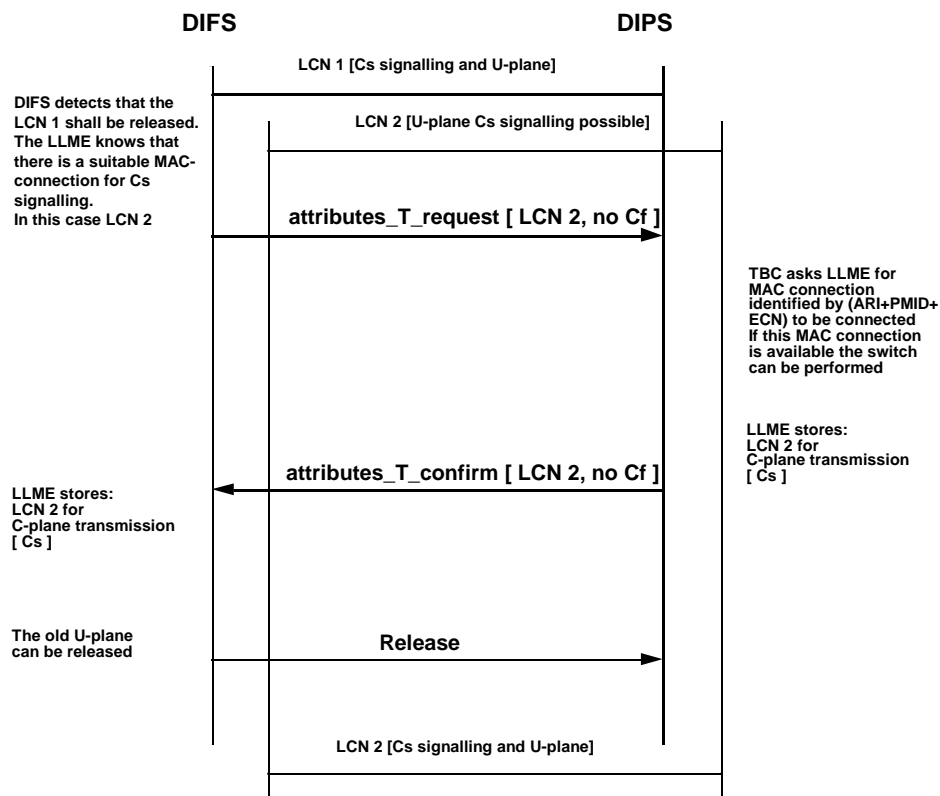

NOTE: The DLC RR_frames are not included in the diagram.

Figure 51: C-plane switching between C_S channels

12.1.5 Switching from C_S to C_F, DIFS initiated

Starting position:

There is one bearer established between DIFS and DIPS:

- 1) U-plane connection LCN 1 [C_S signalling].

The LLME on both sides have stored, that the LCN 1 [C_S] shall be used for C-plane transmission. The DIFS detects that a C_F-channel is necessary.

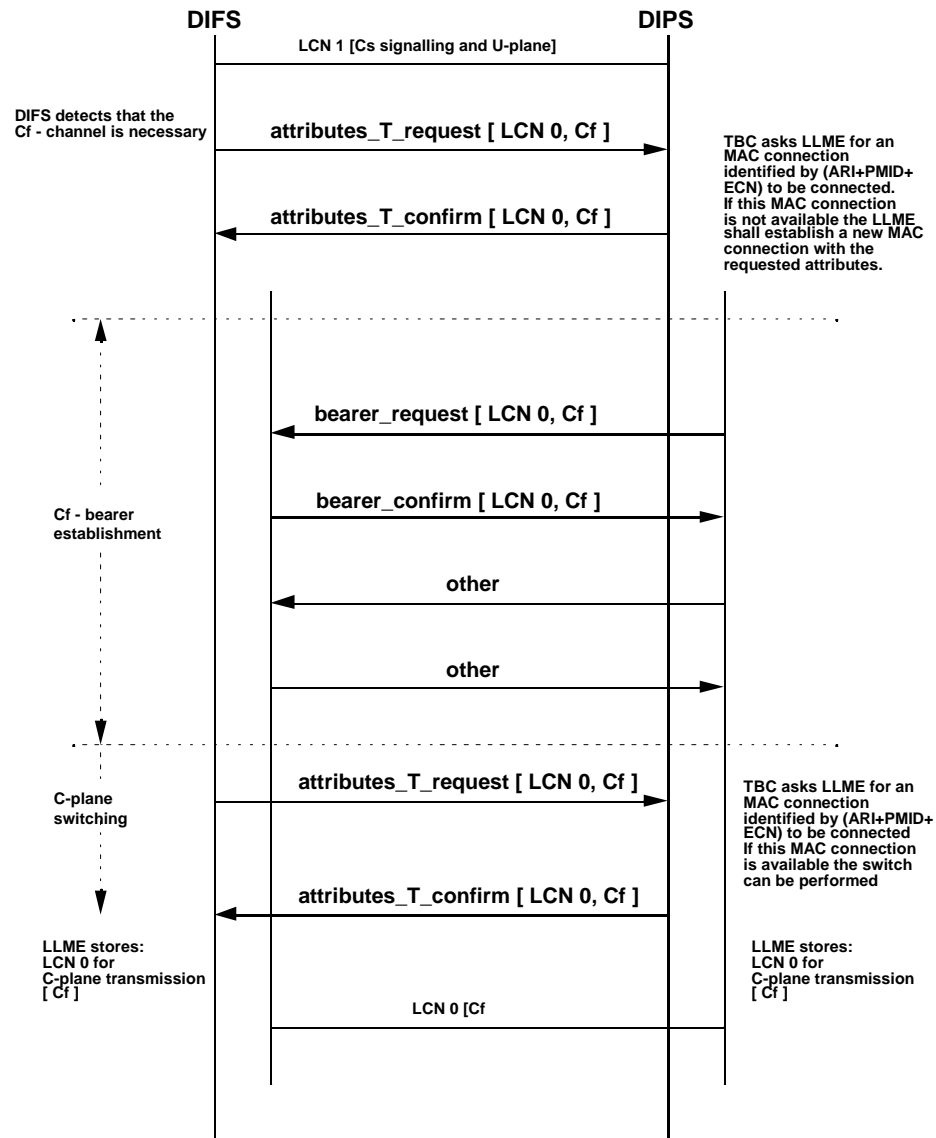

NOTE: The DLC RR_frames are not included in the diagram.

Figure 52: C-plane switching from C_S to C_F, DIFS initiated

12.1.6 Switching from C_S to C_F, DIPS initiated

Starting position:

There is one bearer established between DIFS and DIPS:

- 1) LCN 1 U-plane connection [C_S signalling].

The LLME on both sides have stored, that the LCN 1 [C_S] shall be used for C-plane transmission. The DIPS detects that a C_F-channel is necessary.

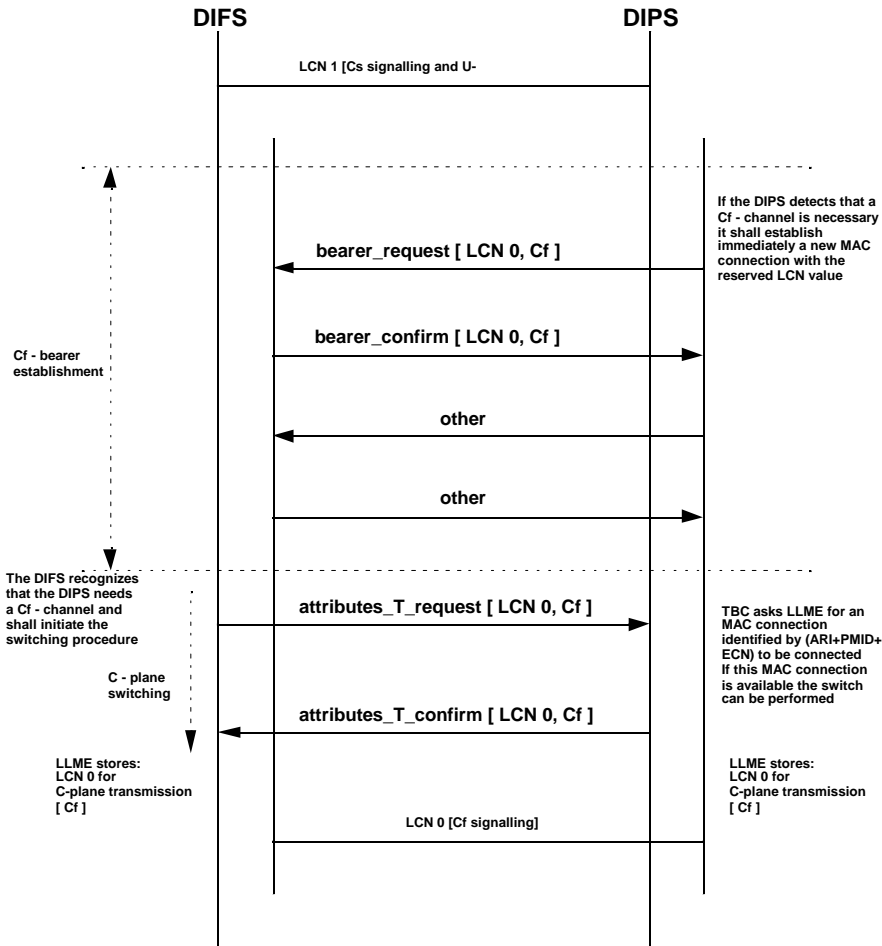

NOTE: The DLC RR_frames are not included in the diagram.

Figure 53: C-plane switching from C_S to C_F, DIPS initiated

12.1.7 LCN - management

The lowest free LCN value is reserved for the MAC bearer carrying the C_F - channel. This LCN value shall not be chosen by the DIFS for a U-plane bearer. LCN values are allowed between 0 and 7.

Examples:

- a) If no bearer between DIFS and DIPS is established the LCN = 0 shall be used for the signalling bearer;
- b) If the bearer with LCN = 0 is already used for a U-plane connection the LCN value 1 is reserved for the fast signalling bearer. In case the DIFS wants to establish a new U-plane connection the DIFS shall not use the reserved LCN value for the C_F - signalling bearer;
- c) If the bearers with LCN = 0 and 1 are already used for a U-plane connection, the LCN value 2 is reserved for the fast signalling bearer.

The DIFS is always able to detect on the reserved LCN value if the DIPS wants to switch to a fast signalling bearer.

12.1.8 Conditions for dynamic signalling channel switching

If the slow signalling channel is in use, the fast signalling channel should be activated by the DIFS in the following cases:

- if an incoming call is detected;
- if the activation of the supplementary service UUS2 or UUS3 is detected;
- if the activation of the supplementary service USBS (user signalling bearer service) is detected.

If the slow signalling channel is in use and the D-channel packet mode is activated, the fast signalling channel shall be activated by the DIFS.

If the slow signalling channel is in use, the fast signalling channel shall be activated by the DIFS or the DIPS if the amount of data queued up in front of the slow signalling channel exceeds a fixed limit.

If the fast signalling channel is in use and if, at least, a U-plane service exists, the slow signalling channel shall be used by the DIFS if no DLC-frame is transmitted and received for a defined period of time (5 second).

12.2 Dynamic switching procedures between DECT U-planes

12.2.1 Dynamic switching procedures from LU1 to LU7

This service is required to switch, during a call (i.e. ACTIVE state), from an LU1 bearer service, advanced connection LCNx, full slot, In minimum delay, to an LU7 bearer service, advanced connection LCNx, double slot, In normal delay.

The DIFS after detecting the switching request (evaluating ISDN layer 3 messages), starts the switching LU1 to LU7 procedure which is managed by the NWK, DLC and MAC layers with the co-ordination of the LLME entity.

The procedure shall be performed as defined in subclauses 9.6, 9.6.1, 9.6.2 and 9.6.3 in ETS 300 175-5 [5]. The following text together with the associated subclauses define the mandatory requirements with regard to this ETS.

Procedure description:

- 1) The IWU in the DIFS, after detecting the switching LU1 to LU7 request, sends the MNCC_INFO-req primitive to the NWK layer starting the switching procedure, ETS 300 175-5 [5], subclause 9.6.
- 2) The NWK in the DIFS sends the {CC-SERVICE-CHANGE} message with the TI value set to indicate the U-plane link that has to be changed and with the complete description of the new service. The NWK layer also informs the LLME that the switching procedure is started.
- 3) The NWK layer in the DIPS after receiving the {CC-SERVICE-CHANGE} message, informs the LLME of the request. If the change is not acceptable the receiving entity shall respond with the {CC-SERVICE-REJECT} message otherwise the LLME starts the switching procedure at the DLC and MAC layer. In this case, only after the conclusion of the DLC and MAC layer switching procedure, the NWK layer at the receiving side shall send the confirm to the peer entity.
- 4) The DLC in the DIPS sends to its MAC layer a MAC_CON-req primitive for connection handover for the connection identified by LCNx. This primitive indicates also that the new connection is: single bearer, double slot, In normal delay.
- 5) The MAC layer then starts the setup of the new bearer using the B-field single bearer setup procedure PT initiated for connection handover.

- 6) At both DIPS and DIFS, after the TBC has reported bearer established, the MAC sends the MAC_CON-cfm and MAC_CON-ind respectively; this means that the switching procedure has been completed and the new connection is now available.
- 7) At both DLC layers, the receipt of this primitive (MAC_CON-cfm or ind) acts as a synchronization signal for the U-plane switching procedure. Then, the DLC in both DIPS and DIFS shall switch correctly the C-plane link and U-plane service and release the old link. The DLC in the DIPS indicates to the LLME that the procedure has been correctly done: the LLME reports this indication to the NWK layer which sends to the DIFS the {CC-SERVICE-ACCEPT} message with the TI value set to indicate the U-plane link that has been changed.
- 8) The DLC in the DIPS, after 80 milliseconds (required for the LU7 service) the new connection is established sends to its MAC the MAC_DIS-req: then the MAC layer shall release the old bearer.

Message flow:

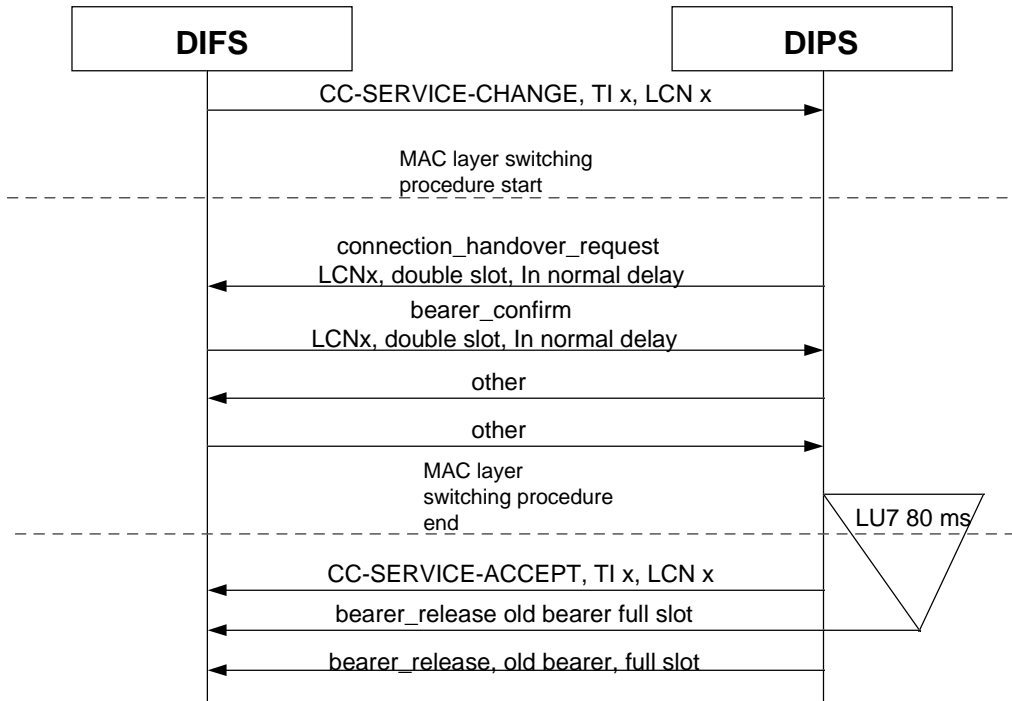

Figure 54: Switching procedure: LU1 to LU7

Table 40: Values used within the {CC-SERVICE-CHANGE} message

Information element	Field within the IE	Standard values within the field/IE	Status	Normative action/comment
<<Portable identity>>			M	
	<Type>	0		IPUI
	<PUT>	All		Area dependent
	<PUN>	All		Area dependent
<<Call attributes>>			M	
	<Coding standard>	0		Octet 3 only: DECT standard coding
	<NWK layer attributes >	All		
	<C-plane class>	All		
	<C-plane routing>	All		
	<U-plane symmetry>	0		Octet 5 only: Symmetric
	<LU identification>	7		LU7
	<U-plane class>	1		Octet 6 only: Class 0 normal_delay
<<Service Change Info>>			M	
	<Coding standard>	0		Octet 3 only: DECT standard coding
	<M >	0		Initiating side is master
	<Change Mode>	6		Re-routeing plus bandwidth change
	<A attributes>	3		Release old connection
	<R>	0/1		Management state variables
	<B attributes>	2/3		Management data transfer
<<Connection Attributes>>			M	
	<Symmetry>	1		Symmetric
	<Connection Identity>	LCNx		Logical Connection number of the old connection
	<Target Bearers P->F>	1		Octet 4 only
	<MAC Slot Size>	5		double slot
	<MAC Service>	1		Octet 5 only: In normal delay
	<C _F channel attributes>	0		C _F never
	<MAC packet lifetime>	0		Octet 6 only

Table 41: Values used within the {CC-SERVICE-ACCEPT} message

Information element	Field within the IE	Standard values within the field/IE	Status	Normative action/comment

Table 42: Values used within the {CC-SERVICE-REJECT} message

Information element	Field within the IE	Standard values within the field/IE	Status	Normative action/comment
<<Release reason>>			M	
	<Release reason code>			

Table 43: Values used within the MAC_CON-req/Ind primitive

Parameter	Information within the parameter	Normative action/comment
<<MCEI>>	MAC Connection Endpoint Identifier	See ETS 300 175-4 [4], subclause 10.2.4.4
<<PMID>>	PMID	See ETS 300 175-3 [3], subclause 11.7.2
<<connection handover>>	Yes	See ETS 300 175-3 [3], subclause 8.1.1
<<C _F required>>	No	See ETS 300 175-3 [3], subclause 8.1.1
<<slot type>>	double slot	
<<service type>>	In normal delay	
<<connection type>>	advanced	
<<ECN>>	Exchanged connection number	See ETS 300 175-4 [4], subclause 10.2.4.2

Table 44: Values used within the MAC_CON-cfm primitive

Parameter	Information within the parameter	Normative action/comment
<<MCEI>>	MAC Connection Endpoint Identifier	See ETS 300 175-4 [4], subclause 10.2.4.4
<<connection type>>	advanced	
<<ECN>>	Exchanged connection number	See ETS 300 175-4 [4], subclause 10.2.4.2

If the MAC layer switching procedure fails in the DIPS, (f. i.e. the connection handover procedure fails), the NKW layer in the DIPS sends to the DIFS the { CC-SERVICE-REJECT } message.

The NWK layer at the DIFS side, after receiving the { CC-SERVICE-ACCEPT } message or the { CC-SERVICE-REJECT } message sends to the IWU the MNCC-INFO-cfm primitive with the result of the switching procedure.

12.2.2 Dynamic switching procedures from LU7 to LU1

This service is required to switch, during a call (i.e. ACTIVE state), from an LU7 bearer service, advanced connection LCNx, double slot, In normal delay, to an LU1 bearer service, advanced connection LCNx, full slot, In minimum delay.

The DIFS after detecting the switching request (evaluating ISDN layer 3 messages), starts the switching LU7 to LU1 procedure which is managed by the NWK, DLC and MAC layers with the co-ordination of the LLME entity.

The procedure shall be performed as defined in subclauses 9.6, 9.6.1, 9.6.2 and 9.6.3 in ETS 300 175-5 [5]. The following text together with the associated subclauses define the mandatory requirements with regard to this ETS.

12.2.2.1 Procedure description

- 1) The IWU in the DIFS, after detecting the switching LU7 to LU1 request, sends the MNCC_INFO-req primitive to the NWK layer starting the switching procedure, ETS 300 175-5 [5], subclause 9.6.
- 2) The NWK in the DIFS sends the {CC-SERVICE-CHANGE} message with the TI value set to indicate the U-plane link that has to be changed and with the complete description of the new service. The NWK layer also informs the LLME that the switching procedure is started.
- 3) The NWK layer in the DIPS after receiving the {CC-SERVICE-CHANGE} message, informs the LLME of the request. If the change is not acceptable the receiving entity shall respond with the {CC-SERVICE-REJECT} message otherwise the LLME starts the switching procedure at the DLC and MAC layer. In this case, only after the conclusion of the DLC and MAC layer switching procedure, the NWK layer at the receiving side shall send the confirm to the peer entity.
- 4) The DLC at the DIPS side then starts the switching procedure at the MAC layer.
- 5) At the MAC layer the following two procedure could be used: The CC-SERVICE-CHANGE message used is defined in subclause 12.2.1 with the LU1 and FU1 indications in the <<Call attributes>> IE. The CC-SERVICE-REJECT and CC-SERVICE-ACCEPT messages are defined in subclause 12.2.1.

12.2.2.1.1 Connection handover procedure

- The DLC in the DIPS sends to its MAC layer a MAC_CON-req primitive for connection handover for the connection identified by LCN. This primitive indicates also that the new connection is: single bearer, full slot, In minimum delay.
- The MAC layer then starts the setup of the new bearer using the B-field single bearer setup procedure PT initiated for connection handover.
- At both DIPS and DIFS, after the TBC has reported bearer established, the MAC sends the MAC_CON-cfm and MAC_CON-ind respectively; this means that the switching procedure has been completed and the new connection is now available.

At both DLC layers, the receipt of this primitive (MAC)CON-cfm or ind) acts as a synchronization signal for the U-plane switching procedure. Then, the DLC in both DIPS and DIFS shall switch correctly the C-plane link and U-plane service and release the old link. The DLC in the DIPS indicates to the LLME that the procedure has been correctly done: the LLME reports this indication to the NWK layer which sends to the DIFS the {CC-SERVICE-ACCEPT} message with the TI value set to indicate the U-plane link that has been changed.

If the MAC layer switching procedure fails in the DIPS, (for instance if the connection handover procedure fails), the NWK layer in the DIPS sends to the DIFS the {CC-SERVICE-REJECT} message.

The NWK layer at the DIFS side, after receiving the {CC-SERVICE-ACCEPT} message or the {CC-SERVICE-REJECT} message, sends to the IWU the MNCC-INFO-cfm primitive with the result of the switching procedure.

Message flow: switching with connection handover procedure:

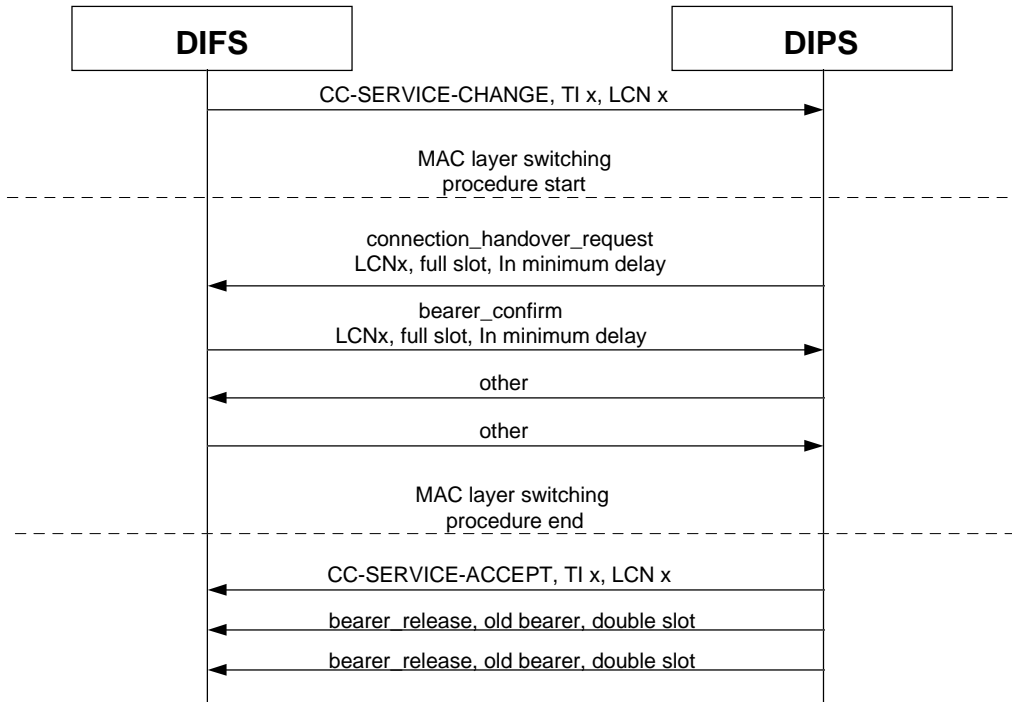

Figure 55: Switching procedure: LU7 to LU1 using connection handover

12.2.2.1.2 Release of the second part of the double slot procedure

The DLC in the DIPS sends to its MAC layer a MAC_MOD-req primitive with the new parameter "switching" set to "double to full". The MAC layer at the DIPS side, starts the switching procedure.

The MAC layer at the DIPS sends the attributes_T_request MAC message (on the A-field) to the FT with the slot type field sets to full: the slot format is actually a double.

The MAC layer at the DIFS, after receiving the attributes_T_request message error free (note), responds with the **attributes_T_confirm** MAC message in the next TDMA frame, with the slot type field set to full: **the slot format is actually a double.**

The DIPS, after receiving the attributes_T_confirm message error free (note), sends an **Other** message in the next TDMA frame on a double slot with the Q2 bit sets to 1 to indicate the correct reception of the attributes_T_request message. The MAC layer then switches from double to full slot releasing the second part of the double slot and sends to its DLC the MAC_MOD-cfm primitive with the "result" parameter sets to accept and the "slot type" parameter sets to full.

The DIFS, after receiving the **Other** message error free (note) on a double slot with the Q2 bit sets to 1 (indication of the correct reception of the attributes_T_confirm) switches to a full slot releasing the second part of the double slot and sends to the DLC the MAC_MOD-ind with the "result" parameter sets to accept and the "slot type" parameter sets to full.

At both DLC layers, the receipt of this primitive (MAC_MOD-cfm or ind) acts as a synchronization signal for the U-plane switching procedure. Then, the DLC in both DIPS and DIFS shall switch correctly the C-plane link and U-plane service and release the old link. The DLC in the DIPS indicates to the LLME that the procedure has been correctly done: the LLME reports this indication to the NWK layer which sends to the DIFS the {CC-SERVICE-ACCEPT} message with the TI value set to indicate the U-plane link that has been changed.

If the MAC layer switching procedure fails in the DIPS, (for instance if the connection handover procedure fails), the NWK layer in the DIPS sends to the DIFS the {CC-SERVICE-REJECT} message.

The NWK layer at the DIFS side, after receiving the {CC-SERVICE-ACCEPT} message or the {CC-SERVICE-REJECT} message, sends to the IWU the MNCC-INFO-cfm primitive with the result of the switching procedure.

NOTE: Error free means with correct A-CRC.

Message flow: switching with release of part of the double slot procedure:

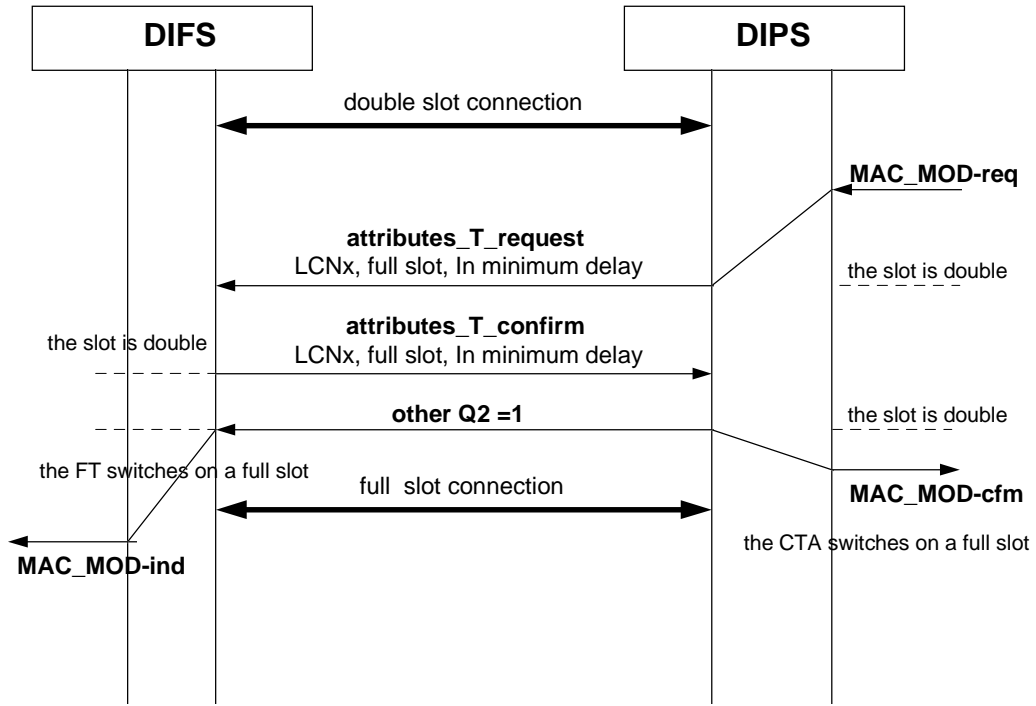

Figure 56: Switching procedure: LU7 to LU1 releasing the second part of the double slot

Error management:

If the DIPS, after sending the attributes_T_request message does not receive the attributes_T_confirm error free (A-CRC correct and Q2 = 1) in the next TDMA frame it shall retransmit the attributes_T_request up to N205 times. If the attributes_T_request transmission fails N205 + 1 times, the switching procedure ends and the MAC_MOD-cfm primitive is sent to the DLC with "result" parameter set to reject (the slot format is still double at both side).

If the DIFS, after sending the attributes_T_confirm message does not receive the other message error free, it shall retransmit the attributes_T_confirm up to N205 times. If the attributes_T_confirm transmission fails N205 + 1 times, the switching procedure ends and the MAC_MOD-ind primitive is sent to the DLC with "result" parameter set to reject and the connection is released.

Table 45: Values used within the {CC-SERVICE-CHANGE} message

Information element	Field within the IE	Standard values within the field/IE	Status	Normative action/comment
<<Portable identity>>			M	
	<Type>	0		IPUI
	<PUT>	All		Area dependent
	<PUN>	All		Area dependent
<<Call attributes>>			M	
	<Coding standard>	0		Octet 3 only: DECT standard coding
	<NWK layer attributes >	All		
	<C-plane class>	All		
	<C-plane routing>	All		
	<U-plane symmetry>	0		Octet 5 only: Symmetric
	<LU identification>	1		LU1
	<U-plane class>	0		Octet 6 only: Class 0 minimum_delay
	<U-plane frame type>	1		FU1
<<Service Change Info>>			M	
	<Coding standard>	0		Octet 3 only: DECT standard coding
	<M >	0		Initiating side is master
	<Change Mode>	6		Re-routeing plus bandwidth change
	<A attributes>	3		Release old connection
	<R>	0/1		Management state variables
	<B attributes>	2/3		Management data transfer
<<Connection Attributes>>			M	
	<Symmetry>	1		Symmetric
	<Connection Identity>	LCNx		Logical Connection number of the old connection
	<Target Bearers P->F>	1		Octet 4 only
	<MAC Slot Size>	4		full slot
	<MAC Service>	0		Octet 5 only: In minimum delay
	<C _F channel attributes>	0		C _F never
	<MAC packet lifetime>	0		Octet 6 only

Table 46: Values used within the {CC-SERVICE-ACCEPT} message

Information element	Field within the IE	Standard values within the field/IE	Status	Normative action/comment

Table 47: Values used within the {CC-SERVICE-REJECT} message

Information element	Field within the IE	Standard values within the field/IE	Status	Normative action/comment
<<Release reason>>			M	
	<Release reason code>			

Table 48: Values used within the MAC_MOD-req/ind primitive

Parameter	Information within the parameter	Normative action/comment
<<MCEI>>	MAC Connection Endpoint Identifier	See ETS 300 175-4 [4], subclause 10.2.4.4
<<ECN>>	Exchanged connection number	See ETS 300 175-4 [4], subclause 10.2.4.2
<<switching type>>	double to full	
<<slot type>>	full, double slot	
<<service type>>	In minimum delay	

Table 49: Values used within the MAC_MOD-cfm primitive

Parameter	Information within the parameter	Normative action/comment
<<MCEI>>	MAC Connection Endpoint Identifier	See ETS 300 175-4 [4], subclause 10.2.4.4
<<ECN>>	Exchanged connection number	See ETS 300 175-4 [4], subclause 10.2.4.2
<<slot type>>	full, double slot	

12.2.2.1.3 Associated procedures

N205 switching attemp counter

Value	6 times;
Start	DIPS side: the attributes_T_request is sent; DIFS side: the attributes_T_confirm is sent.
Change	DIPS side: a new attributes_T_request is sent; DIFS side: a new the attributes_T_confirm is sent.
Clear	DIPS side: the attributes_T_confirm is received; DIFS side: the other message with Q2 sets to 1 is received.

12.2.3 Dynamic switching procedures from LU1 to LU8

This service is required to switch, during a call (i.e. ACTIVE state), from an LU1 bearer service, advanced connection LCNx, full slot, In minimum delay, to an LU8 bearer service, advanced connection LCNx, double slot, In normal delay.

The DIFS after detecting the switching request (for instance detecting the 2 100 Hz modem tone over the U-plane link) starts the switching LU1 full slot to LU8 double slot procedure which is managed by the NWK, DLC and MAC layers with the co-ordination of the LLME entity.

The procedure shall be performed as defined in subclause 12.2.1 of this ETS. The following text together with the associated subclauses define the mandatory requirements with regard to this procedure.

Table 50: Values used within the {CC-SERVICE-CHANGE} message

Information element	Field within the IE	Standard values within the field/IE	Status	Normative action/comment
<<Portable identity>>			M	
	<Type>	0		IPIU
	<PUT>	All		Area dependent
	<PUN>	All		Area dependent
<<Call attributes>>			M	
	<Coding standard>	0		Octet 3 only: DECT standard coding
	<NWK layer attributes >	All		
	<C-plane class>	All		
	<C-plane routing>	All		
	<U-plane symmetry>	0		Octet 5 only: Symmetric
	<LU identification>	8		LU8
	<U-plane class>	1		Octet 6 only: Class 0 normal_delay
	<U-plane frame type>	8		FU8
<<Service Change Info>>			M	
	<Coding standard>	0		Octet 3 only: DECT standard coding
	<M >	0		Initiating side is master
	<Change Mode>	6		Re-routeing plus bandwidth change
	<A attributes>	3		Release old connection
	<R>	0/1		Management state variables
	<B attributes>	2/3		Management data transfer
<<Connection Attributes>>			M	
	<Symmetry>	1		Symmetric
	<Connection Identity>	LCNx		Logical Connection number of the old connection
	<Target Bearers P->F>	1		Octet 4 only
	<MAC Slot Size>	5		double slot
	<MAC Service>	1		Octet 5 only: In normal delay
	<C _F channel attributes>	0		C _F never
	<MAC packet lifetime>	0		Octet 6 only

12.2.4 Dynamic switching procedures from U-plane LU8 to LU1

This service is required to switch, during a call (i.e. ACTIVE state), from an LU8 bearer service, advanced connection LCNx, double slot, In normal delay, to an LU1 bearer service, advanced connection LCNx, full slot, In minimum delay.

The DIFS after detecting the switching request starts the switching LU8 to LU1 procedure which is managed by the NWK, DLC and MAC layers with the co-ordination of the LLME entity.

The procedure shall be performed as defined in subclause 12.2.2 of this ETS. The following text together with the associated subclauses define the mandatory requirements with regard to this procedure.

Table 51: Values used within the {CC-SERVICE-CHANGE} message

Information element	Field within the IE	Standard values within the field/IE	Status	Normative action/comment
<<Portable identity>>			M	
	<Type>	0		IPUI
	<PUT>	All		Area dependent
	<PUN>	All		Area dependent
<<Call attributes>>			M	
	<Coding standard>	0		Octet 3 only: DECT standard coding
	<NWK layer attributes >	All		
	<C-plane class>	All		
	<C-plane routing>	All		
	<U-plane symmetry>	0		Octet 5 only: Symmetric
	<LU identification>	1		LU1
	<U-plane class>	0		Octet 6 only: Class 0 minimum_delay
	<U-plane frame type>	1		FU1
<<Service Change Info>>			M	
	<Coding standard>	0		Octet 3 only: DECT standard coding
	<M >	0		Initiating side is master
	<Change Mode>	6		Re-routeing plus bandwidth change
	<A attributes>	3		Release old connection
	<R>	0/1		Management state variables
	<B attributes>	2/3		Management data transfer
<<Connection Attributes>>			M	
	<Symmetry>	1		Symmetric
	<Connection Identity>	LCNx		Logical Connection number of the old connection
	<Target Bearers P->F>	1		Octet 4 only
	<MAC Slot Size>	4		full slot
	<MAC Service>	0		Octet 5 only: In minimum delay
	<C _F channel attributes>	0		C _F never
	<MAC packet lifetime>	0		Octet 6 only

12.2.4.1 Dynamic switching procedures from LU7 to LU8

This service is required to switch, during a call (i.e. ACTIVE state), from an LU7 bearer service, advanced connection LCNx, double slot, In normal delay, to an LU8 bearer service, advanced connection LCNx, double slot, In normal delay.

The DIFS after detecting the switching request (evaluating ISDN layer 3 messages), starts the switching LU7 to LU8 procedure which is managed by the NWK layer with the co-ordination of the LLME entity.

The procedure shall be performed as defined in subclauses 9.6, 9.6.1, 9.6.2 and 9.6.3 in ETS 300 175-5 [5]. The following text together with the associated subclauses define the mandatory requirements with regard to this ETS.

12.2.4.1.1 Procedure description

- 1) The IWU in the DIFS, after detecting the switching LU7 to LU8 request, sends the MNCC_INFO-req primitive to the NWK layer starting the switching procedure, ETS 300 175-5 [5], subclause 9.6.
- 2) The NWK in the DIFS sends the {CC-SERVICE-CHANGE} message with the TI value set to indicate the U-plane link that has to be changed and with the complete description of the new service. The NWK layer also informs the LLME that the switching procedure is started.
- 3) The NWK layer in the DIPS after receiving the {CC-SERVICE-CHANGE} message, informs the LLME of the request. If the change is not acceptable the receiving entity shall respond with the {CC-SERVICE-REJECT} message otherwise the receiving entity shall respond with the {CC-SERVICE-ACCEPT} message.
- 4) If the request is acceptable, after sending the confirmation message, the LLME at the DIPS side shall inform its DLC layer about the new U-plane service characteristics of the connection and the DLC layer shall make the U-plane switching.
- 5) The NWK layer at the DIFS side, after receiving the {CC-SERVICE-REJECT} message, sends to the IWU the MNCC-INFO-cfm primitive with the result of the switching procedure.
- 6) The NWK layer at the DIFS side, after receiving the {CC-SERVICE-ACCEPT} message, sends to the IWU the MNCC-INFO-cfm primitive with the result of the switching procedure and informs the LLME of the response. The LLME then shall inform the DLC layer about the new U-plane service characteristics of the connection and the DLC layer shall make the U-plane switching.

Table 52: Values used within the {CC-SERVICE-CHANGE} message

Information element	Field within the IE	Standard values within the field/IE	Status	Normative action/comment
<<Portable identity>>			M	
	<Type>	0		IPUI
	<PUT>	All		Area dependent
	<PUN>	All		Area dependent
<<Call attributes>>			M	
	<Coding standard>	0		Octet 3 only: DECT standard coding
	<NWK layer attributes >	All		
	<C-plane class>	All		
	<C-plane routing>	All		
	<U-plane symmetry>	0		Octet 5 only: Symmetric
	<LU identification>	8		LU8
	<U-plane class>	0		Octet 6 only: Class 1 normal_delay
<<Service Change Info>>			M	
	<Coding standard>	0		Octet 3 only: DECT standard coding
	<M >	0		Initiating side is master
	<Change Mode>	6		Re-routeing plus bandwidth change
	<A attributes>	3		Release old connection
	<R>	0/1		Management state variables
	<B attributes>	2/3		Management data transfer
<<Connection Attributes>>			M	
	<Symmetry>	1		Symmetric
	<Connection Identity>	LCNx		Logical Connection number of the old connection
	<Target Bearers P->F>	1		Octet 4 only
	<MAC Slot Size>	4		double slot
	<MAC Service>	0		Octet 5 only: In normal delay
	<C _F channel attributes>	0		C _F never
	<MAC packet lifetime>	0		Octet 6 only

For the {CC-SERVICE-ACCEPT} and the {CC-SERVICE-REJECT} messages the structure already defined in subclause 12.2.1 shall be used.

12.2.4.2 Dynamic switching procedures from LU8 to LU7

This service is required to switch, during a call (i.e. ACTIVE state), from an LU8 bearer service, advanced connection LCNx, double slot, In normal delay, to an LU7 bearer service, advanced connection LCNx, double slot, In normal delay.

The DIFS after detecting the switching request (evaluating ISDN layer 3 messages), starts the switching LU8 to LU7 procedure which is managed by the NWK layer with the co-ordination of the LLME entity.

The procedure shall be performed as defined in subclauses 9.6, 9.6.1, 9.6.2 and 9.6.3 in ETS 300 175-5 [5]. The following text together with the associated subclauses define the mandatory requirements with regard to this ETS.

12.2.4.2.1 Procedure description

1. The IWU in the DIFS, after detecting the switching LU8 to LU7 request, sends the MNCC_INFO-req primitive to the NWK layer starting the switching procedure, ETS 300 175-5 [5], subclause 9.6.
- 2) The NWK in the DIFS sends the {CC-SERVICE-CHANGE} message with the TI value set to indicate the U-plane link that has to be changed and with the complete description of the new service. The NWK layer also informs the LLME that the switching procedure is started.
- 3) The NWK layer in the DIPS after receiving the {CC-SERVICE-CHANGE} message, informs the LLME of the request. If the change is not acceptable the receiving entity shall respond with the {CC-SERVICE-REJECT} message otherwise the receiving entity shall respond with the {CC-SERVICE-ACCEPT} message.
- 4) If the request is acceptable, after sending the confirmation message, the LLME at the DIPS side shall inform its DLC layer about the new U-plane service characteristics of the connection and the DLC layer shall make the U-plane switching.
- 5) The NWK layer at the DIFS side, after receiving the {CC-SERVICE-REJECT} message, sends to the IWU the MNCC-INFO-cfm primitive with the result of the switching procedure.
- 6) The NWK layer at the DIFS side, after receiving the {CC-SERVICE-ACCEPT} message, sends to the IWU the MNCC-INFO-cfm primitive with the result of the switching procedure and informs the LLME of the response. The LLME then shall inform the DLC layer about the new U-plane service characteristics of the connection and the DLC layer shall make the U-plane switching.

Table 53: Values used within the {CC-SERVICE-CHANGE} message

Information element	Field within the IE	Standard values within the field/IE	Status	Normative action/comment
<<Portable identity>>			M	
	<Type>	0		IPUI
	<PUT>	All		Area dependent
	<PUN>	All		Area dependent
<<Call attributes>>			M	
	<Coding standard>	0		Octet 3 only: DECT standard coding
	<NWK layer attributes >	All		
	<C-plane class>	All		
	<C-plane routing>	All		
	<U-plane symmetry>	0		Octet 5 only: Symmetric
	<LU identification>	1		LU7
	<U-plane class>	0		Octet 6 only: Class 1 normal_delay
	<U-plane frame type>	1		FU7
<<Service Change Info>>			M	
	<Coding standard>	0		Octet 3 only: DECT standard coding
	<M >	0		Initiating side is master
	<Change Mode>	6		Re-routeing plus bandwidth change
	<A attributes>	3		Release old connection
	<R>	0/1		Management state variables
	<B attributes>	2/3		Management data transfer
<<Connection Attributes>>			M	
	<Symmetry>	1		Symmetric
	<Connection Identity>	LCNx		Logical Connection number of the old connection
	<Target Bearers P->F>	1		Octet 4 only
	<MAC Slot Size>	4		double slot
	<MAC Service>	0		Octet 5 only: In normal delay
	<C _F channel attributes>	0		C _F never
	<MAC packet lifetime>	0		Octet 6 only

For the {CC-SERVICE-ACCEPT} and the {CC-SERVICE-REJECT} messages the structure already defined in subclause 12.2.1 shall be used.

13 Maintenance

13.1 Exchange of operation and maintenance information

The DIFS and DIPS exchange operation and maintenance information by including an <<IWU-TO-IWU>> IE with protocol discriminator (PD) indicating "DECT/ISDN Intermediate System Operation and Maintenance specific".

NOTE: See also subclause 14.2 for coding of the IE.

14 Coding

14.1 IWU-INFORMATION for DECT/ISDN intermediate system

This message is used to transparently exchange external protocol information over an active L3 call.

Message Type	Format	Directions
IWU-INFORMATION	S	Both

Information Element	F to P message	P to F message	Length octets
Protocol Discriminator	M	M	1/2
Transaction Identifier	M	M	1/2
Message Type	M	M	1
Portable identity	O	O	5-20
Repeat Indicator (note)	O	O	1
IWU-TO-IWU	M	M	4-*

M: Mandatory
 O: Optional

NOTE: The <<REPEAT-INDICATOR>> element is used if the complete information field cannot be fitted into one IE of the message.

14.2 IWU to IWU for DECT/ISDN intermediate system

This IE is used to transport e.g. external protocol information.

If the IWU-TO-IWU INFORMATION field is too large to fit into a single <<IWU-TO-IWU>> IE, it shall be segmented into a series of <<IWU-TO-IWU>> IEs that are preceded by the <<REPEAT-INDICATOR>> IE.

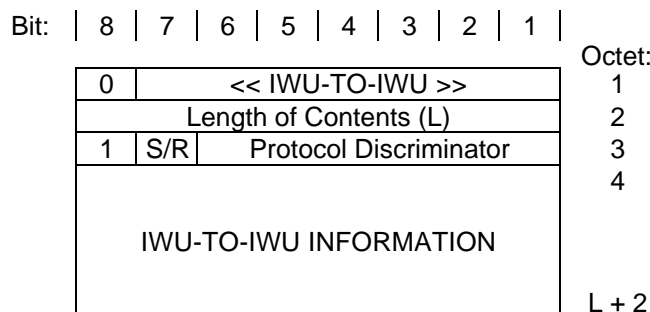

IWU-TO-IWU IE

Send/Reject (S/R) bit:

Bits	7	Meaning
	1	Transmission of message

Protocol Discriminator (PD):

Bits	6 5 4 3 2 1	Meaning
	1 0 0 0 0 0	DECT/ISDN Intermediate System C-plane specific
	1 0 0 0 0 1	DECT/ISDN Intermediate System U-plane specific
	1 0 0 0 1 0	DECT/ISDN Intermediate System Operation and Maintenance
	1 1 1 1 1 1	Unknown
	X X X X X X	All other values reserved.

NOTE: Only the codings which are used in this ETS are included in the table.

14.2.1 C-plane specific

The IWU-TO-IWU INFORMATION field for C-plane specific is structured as shown below.

IWU-TO-IWU information field (octets 4 to L + 2) for Protocol Discriminator value "DECT/ISDN Intermediate System C-plane specific":

Bit:	8 7 6 5 4 3 2 1	Octet:	
	ISDN L2 Command	Cause	4
	LA CEI		5 - 6

ISDN L2 Command coding (Bit 8 to 4 of octet 4):

Bits	8 7 6 5 4	Meaning
	1 0 0 0 0	L2 release required
	1 0 0 0 1	L2 establishment required
	1 0 0 1 0	Unnumbered Information transfer
	1 0 0 1 1	Numbered Information transfer

DIPS Connection Endpoint Identifier (octets 5 - 6):

Bit:	8 7 6 5 4 3 2 1	Octet:	
	SAPI	x x	5
	TEI	x	6

x: do not care

14.2.1.1 Coding for "release required"

Bit:	8 7 6 5 4 3 2 1	Octet:	
	Release required	Cause	4
	LA CEI		5-6
	Diagnostics		7

Octet 4: bit 8 - 4 as drafted in the present version.

Bit			
3	2	1	
0	0	1	normal
0	1	0	error

Octet 4: bit 3 - 1:

Cause			
0	0	1	Normal
0	1	0	Error

Octet 7: conflicted L2 command if L2 command = release required with cause "error".

Further information covering the LA CEI can be found in subclause 11.1.

ISDN L3 message (octets 7 to L + 2).

(Refer to ETS 300 403-1 [14] and ITU-T Recommendation Q.931 [26]).

14.2.1.2 Coding for "other" L2 commands

Proposal for the structure of the L-2 command "other":

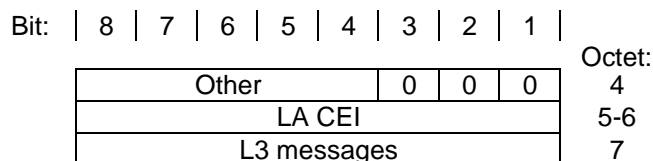

Octet 4: bit 8 - 4 as drafted in the present version.

Further information covering the LA CEI can be found in subclause 11.1.

ISDN L3 message (octets 7 to L + 2).

(Refer to ETS 300 403-1 [14] and ITU-T Recommendation Q.931 [26]).

14.2.2 U-plane specific

The IWU-TO-IWU INFORMATION field for U-plane specific is structured as shown below.

IWU-TO-IWU information field (octets 4 to L + 2) for Protocol Discriminator value "DECT/ISDN Intermediate System U-plane specific B-channel Command":

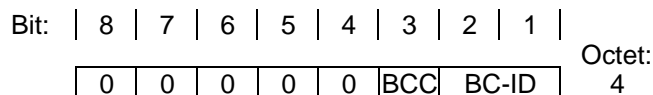

BCC: B-channel command
 BC-ID: B-channel identification

B-channel Command (Bit 3 of octet 4):

Bits	3	Meaning
	0	B-channel connect
	1	B-channel disconnect

B-channel Id (Bits 2 to 1 of octet 4):

Bits	2	1	Meaning
	0	0	no B channel
	0	1	B1 channel
	1	0	B2 channel

14.2.3 Operation and maintenance specific

The IWU-TO-IWU INFORMATION field for OA&M specific is structured as shown below.

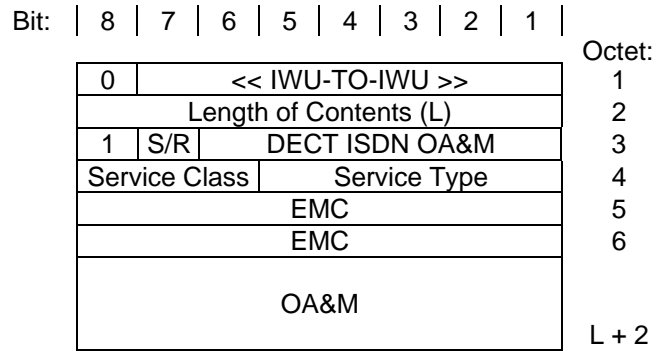

Service Class codings

Bits	8	7	6	Meaning
	1	1	1	Proprietary
	0	1	0	Standardized

EMC shall only be included for the service class coding "Proprietary".

Annex A (informative): Modifications to ETS 300 175

A.1 Modifications to the MAC layer (ETS 300 175-3)

A.1.1 Specific for U-plane switching procedures

To provide the Dynamic U-plane switching services, some new MAC layer procedures have been defined in this ETS in subclauses 12.3, 12.4, 12.5 and 12.6. A new MAC layer constant N205 (see subclause 21.4.2.1.1) has been defined to manage all these procedures and the MAC_MOD primitive has changed as follows:

Table A.1: Connection modification: MAC_MOD {req, cfm, ind}

Parameter	req	ind	cfm
MCEI	X	X	X
ECN	X	X	X
switching	X	X	-
slot type	X	X	-
service type	X	X	-
max lifetime	X	X	-
target number of uplink simplex bearers	X	-	-
target number of downlink simplex bearers	X	-	-
minimum acceptable uplink simplex bearers	X	-	-
minimum acceptable downlink simplex bearers	X	-	-
X = parameter exists - = parameter optional			

MCEI = local matter;

ECN = {0, 1, ... 15};

switching: {full to double, double to full, full to full, full to half};

slot type = {double, full, half with j = 0};

service type = {I_N_minimum_delay, I_N_normal_delay, I_P_error_detection, I_P_error_correction, C-channel only};

maximum lifetime = {unlimited, 1, 2, ... , 7};

target number of uplink simplex bearers = {1,2, ... 30};

target number of downlink simplex bearers = {1,2, ... 30};

minimum acceptable uplink simplex bearers = {1,2, ... 30};

minimum acceptable downlink simplex bearers= {1,2, ... 30}.

A.1.2 Specific for C-plane switching procedure

To provide the Dynamic C-plane switching services, some new MAC layer procedures have been defined in this ETS in subclauses 8.1.4, 8.1.4.1, 8.1.4.2, 8.1.4.3, 8.1.4.4 and 8.1.4.5.

A new MAC layer constant N204 and a new MAC layer timer T217 (see subclause 8.1.4.5) and the following two new MAC primitives, MAC_CS_CF and MAC_CSCF_END have been defined to manage all these procedures.

C-channel switching: MAC_CS_CF {req, cfm, ind, res}

Table A.2: Parameter list

Parameter	req	ind	res	cfm
MCEI	X	X	X	X
LCN old	X	X	X	X
LCN new	X	X	X	X
switching type	X	X	X	X
result	X	X	X	X
status	X	X	X	X
X= parameter exists - = parameter optional				

MCEI = local matter;
 LCN old = {0, 1, ...,7};
 LCN new = {0, 1, ...,7};
 switching type: {C_S to C_F, C_F to C_S, C_S to C_S};
 result: accept/reject;
 status: {start, stop}.

C-channel switching: MAC_CSCF_END {ind}

Table A.3: Parameter list

Parameter	ind
MCEI	X
LCN old	X
LCN new	X
switching type	X
result	X
status	X
X = parameter exists - = parameter optional	

MCEI = local matter;
 LCN old = {0, 1, ...,7};
 LCN new = {0, 1, ...,7};
 switching type: { C_S to C_F, C_F to C_S, C_S to C_S};
 result: accept/reject;
 status: {start, stop}.

Add a new MAC layer Timer T217 and a new MAC layer counter N204 as defined in subclause 8.1.4.5.

A.2 Modifications to the DLC layer (ETS 300 175-4)

A.2.1 General

A new LU8 service is defined in subclause 9.2.3.

A new FU8 frame structure is defined in subclause 9.2.3.

A.2.1.1 LU7 64 kbit/s data bearer service

See ETS 300 175-4 [4] for a description of the 64 kbit/s data bearer service specified for the DECT radio interface.

A.2.1.2 LU8 bearer service

A.3 Modifications to the NWK layer (ETS 300 175-5)

A.3.1 General

A broadcast bit in the higher layer capabilities of the extended FP capabilities is reserved for indicating DECT/ISDN intermediate system support.

The broadcast bit used is shown in table A.4 (modified table F.2 of ETS 300 175-5 [5]).

If the IIP is supported, then the bit a42 corresponding to that profile is set to 1; otherwise (if IIP is not supported) the bit is set to 0.

Table A.4: Modified table F.1 of ETS 300 175-5 [5]: Extended FP capabilities

bit number	Profile supported
a47	ISDN Data Services
a46	Data Service Profile A/B Class 1
a45	Data Service Profile A/B Class 2
a44	Data Service Profile C Class 2
a43	Data Service Profile F
a42	ISDN intermediate system
a12 to a41	Reserved for future standardization
NOTE 1:	The bit numbers refer to the bit positions in the MAC message. Refer to subclause 7.2.3.5 in ETS 300 175-3 [3].
NOTE 2:	The default setting for all bits shall be "0"; meaning "not available".

The protocol discriminator field used in the <<IWU-TO-IWU>> IE has to be updated as follows:

Protocol Discriminator (PD):

Bits	6 5 4 3 2 1	Meaning
	0 0 0 0 0	User Specific
	0 0 0 0 1	OSI high layer protocols
	0 0 0 1 0	CCITT Recommendation X.244
	0 0 0 1 0 0	IA5 characters
	0 0 0 1 1 1	CCITT Recommendation V.120, Rate adaptation
	0 0 1 0 0 0	CCITT Recommendation Q.931, message
	0 0 1 0 0 1	CCITT Recommendation Q.931, element(s)
	0 0 1 0 1 0	CCITT Recommendation Q.931, partial message
	0 1 0 0 0 0	GSM Recommendation 04.08, message
	0 1 0 0 0 1	GSM Recommendation 04.08, element(s)
	1 0 0 0 0 0	DECT/ISDN Intermediate System C-plane specific
	1 0 0 0 0 1	DECT/ISDN Intermediate System U-plane specific
	1 0 0 0 1 0	DECT/ISDN Intermediate System Operation and Maintenance
	1 1 1 1 1 1	Unknown
	X X X X X X	All other values reserved.

A.3.2 Specific for U-plane switching procedures

The IE <<Call attributes>> has to be added to the CC-SERVICE-CHANGE message. The new format of the message is the following:

Message Type	Format	Direction
{CC-SERVICE-CHANGE}	S	Both

Information Element	Subclause	F to P message	P to F message	Length octets
Protocol Discriminator	7.2	M	M	½
Transaction Identifier	7.3	M	M	½
Message Type	7.4	M	M	1
Portable identity	7.7.30	M	M	5-20
IWU attributes	7.7.21	O	O	5-12
Service Change Info	7.7.38	M	M	4-5
Call attributes (note)	7.7.5	M/O	-	6-8
Repeat Indicator	7.6.3	O	O	1
Connection Attributes	7.7.11	M/O	M/O	6-11
Connection Identity	7.7.12	M/O	M/O	3-*
Escape to proprietary	7.7.45	O	O	2-*
NOTE: The <<Call attributes>> element is mandatory for the dynamic switching between different LU service types.				

In the call attributes IE a new LU identification code and a new U-plane frame type code have been added as follows:

LU identification

Bits	5 4 3 2 1	Meaning
	0 1 0 0 0	LU8

U-plane frame type

Bits	4	3	2	1	Meaning
	1	0	0	0	FU8

NOTE: Only the codings which are used in this ETS are included.

A.3.3 Amendment to basic service IE

Basic Service (octet 2):

Bits	4	3	2	1	Meaning
	0	1	1	1	DECT/ISDN IIP

Annex B (informative): Handover and collision scenarios

B.1 C-plane switching procedures

B.1.1 C-plane switching: handover collision scenarios

B.1.1.1 C_F to C_S switching procedure: concurrent handover scenario

The DIFS decides to transfer the signalling channel from a C_F channel connection LCN0 to a C_S channel connection LCN1. The MAC layer switching procedure starts as already described in subclause 8.1.4.

During the switching procedure an handover procedure is started from the DIPS: the DIPS requires a new bearer or connection instead of the LCN0. The request is sent after the switching procedure has already been started from the DIFS and the attributes_T_request message has been already received at the DIPS side on the LCN0 connection.

The DIPS shall send the attributes_T_confirm on the new bearer or connection only if the other message which ends positively the handover procedure will be received: in this case the switching procedure can continue on the new bearer or connection. Otherwise if the DIPS has not yet received the other message but has only received the wait message, the attributes_T_confirm should be sent on the old bearer or connection.

The following two scenarios proposed in figures B.1 and B.2, describe the two different DIPS behaviours.

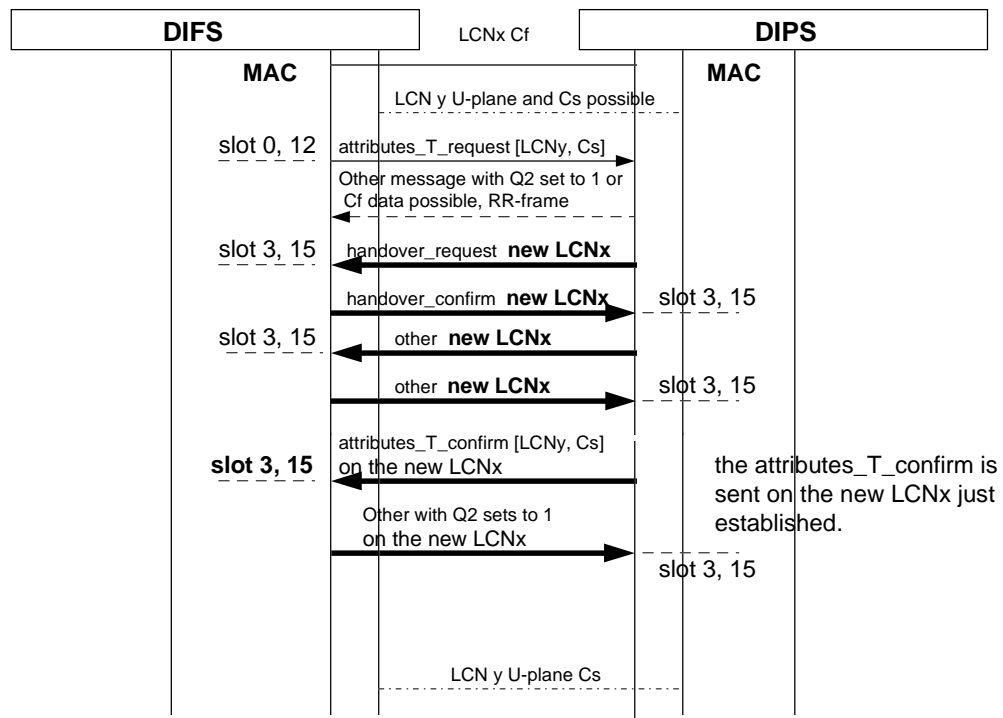

Figure B.1: C_F to C_S - first scenario

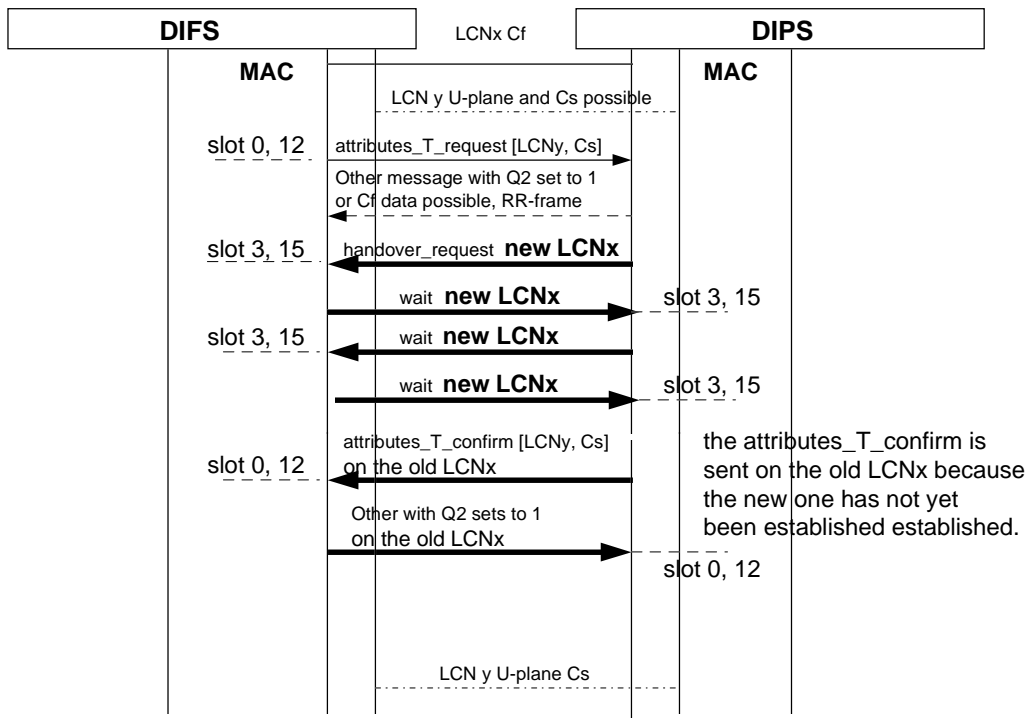

Figure B.2: C_F to C_S - second scenario

B.1.1.2 C_S to C_F switching procedure: concurrent handover scenario

The DIFS decides to transfer the signalling channel from a C_S channel connection LCN0 to a new C_F channel connection LCN1 that has to be established. The MAC layer switching procedure starts as already described in subclause 8.1.4.

During the switching procedure an handover procedure is started from the DIPS: the DIPS requires a new bearer or connection instead of the LCN0. The request is sent after the switching procedure has already been started from the DIFS and the `attributes_T_request` message has been already received at the DIPS side on the LCN0 connection.

The DIPS shall send the `attributes_T_confirm` on the new bearer or connection only if the other message, which ends positively the handover procedure, will be received: in this case the switching procedure can continue on the new bearer or connection. Otherwise if the DIPS has not yet received the other message but has only received the wait message, the `attributes_T_confirm` should be sent on the old bearer or connection.

The following two scenarios proposed in figures B.3 and B.4, describe the two different DIPS behaviours.

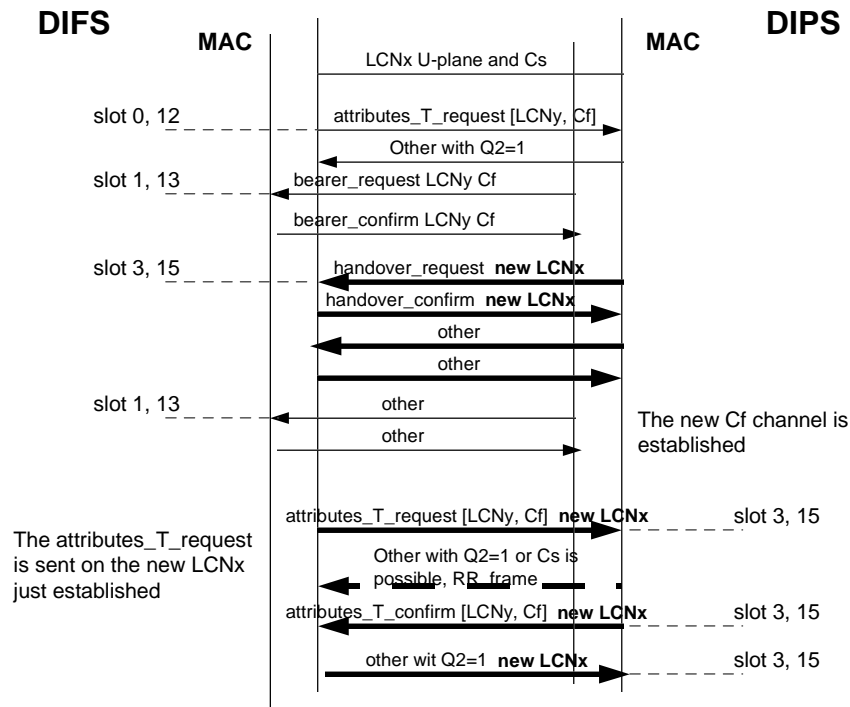

Figure B.3: C_S to C_F - first scenario

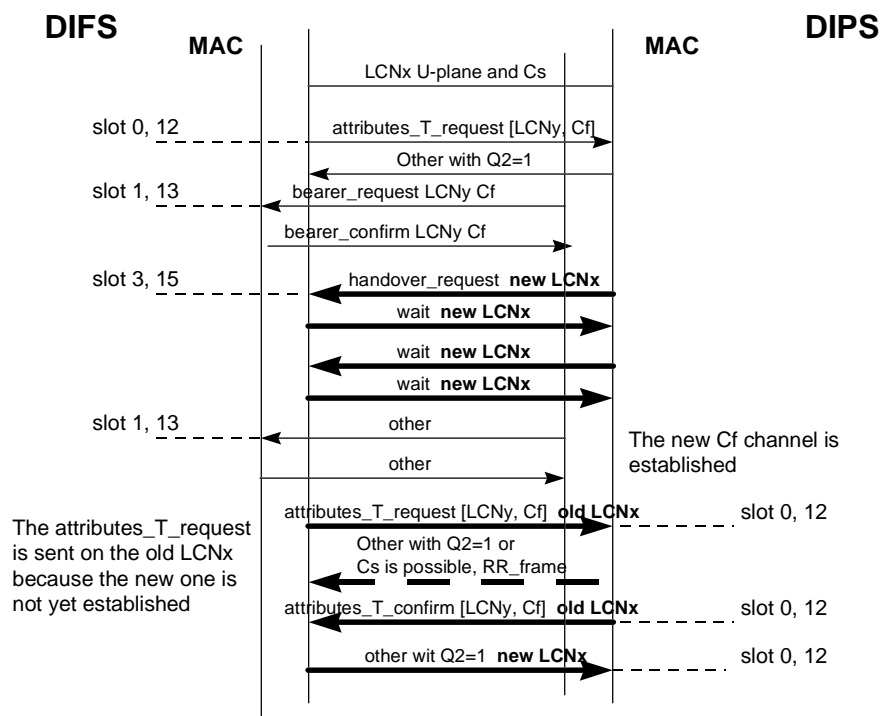

Figure B.4: C_S to C_F - second scenario

B.1.1.3 Dynamic switching C_F to C_S bearer handover collision

Figure B.5 contains an example of collision between the bearer handover procedure and the C_F to C_S switching procedure.

The D-channel is on the LCN_x connection slot 3/15; the DIFS decides to move it to the LCN_y connection C_S channel on slot 7/19 and starts the procedure sending the attributes_T_request Mt message: a bearer handover request for the LCN_x bearer is requested by the DIPS on slot 0, 12:

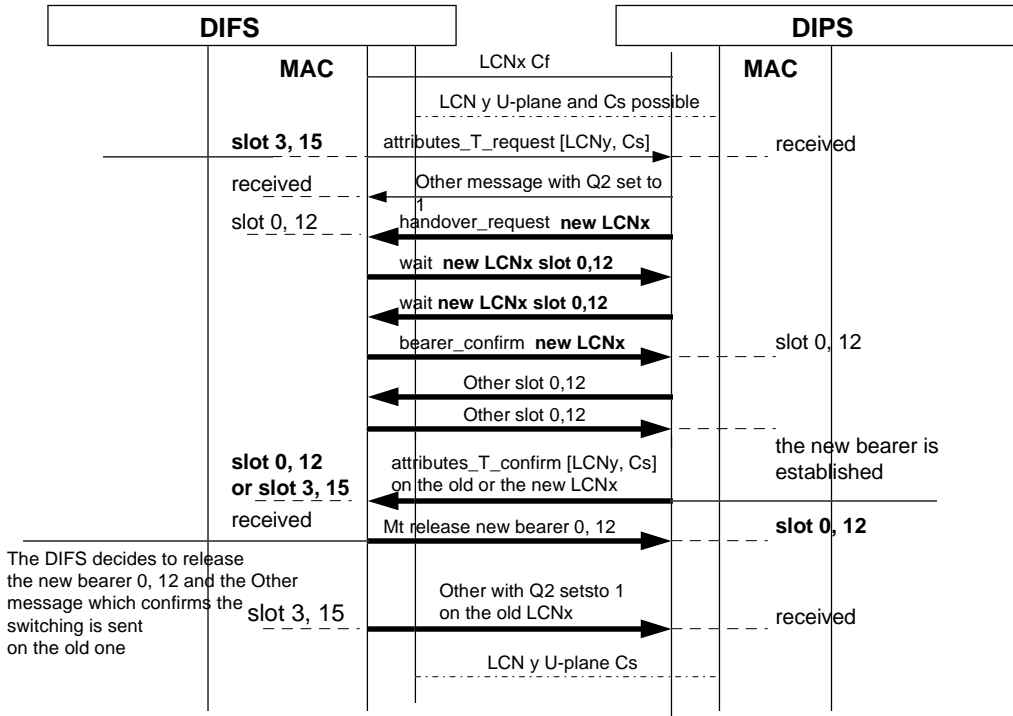

Figure B.5: Collision bearer handover and C_F to C_S

As indicated in this scenario the attributes_T_confirm is sent on the new bearer but due to the decision of the DIFS to release the new one (this is possible), the Other message of confirmation of the correct reception of the attributes_T_confirm is sent by the DIFS on the old bearer and the new one is released.

B.1.1.4 Conclusions

Considering all the previous scenarios some conclusions could be made:

- 1) the attributes_T_confirm message shall be sent on:
 - the old bearer if the new one has not yet been established;
 - on the old bearer or the new one when both of them are available;
 - on the one which is maintained when the other one is released.
- 2) the response to the attributes_T_confirm, other message with Q2 = 1 shall be sent on:
 - the old bearer if the new one has not yet been established;
 - on the old bearer or the new one when both of them are available;
 - on the one which is maintained when the other one is released.

The same considerations could be applied to the other C-channel switching procedures (C_S to C_F or C_S to C_S).

In general, all the MAC messages related to the dynamic switching procedures C_S/C_F shall be sent and could be received by DIFS or DIPS on the bearer which is established: during the bearer handover procedure, when both the new and the old bearer are available, the MAC messages could be sent or received either on the new or the old bearer.

B.1.2 C-plane switching: ciphering procedure collision scenarios

B.1.2.1 Dynamic switching C_F to C_S ciphering procedure collision

The DIFS decides to move the D-channel from the $LCN_x C_F$ connection to the $LCN_y C_S$ connection and starts the switching scenario. During the MAC layer switching scenario a MAC layer start ciphering scenario is activated by the DIPS for the LCN_x connection: the ciphering scenario interferes with the switching one suspending it.

The following worst case could happen:

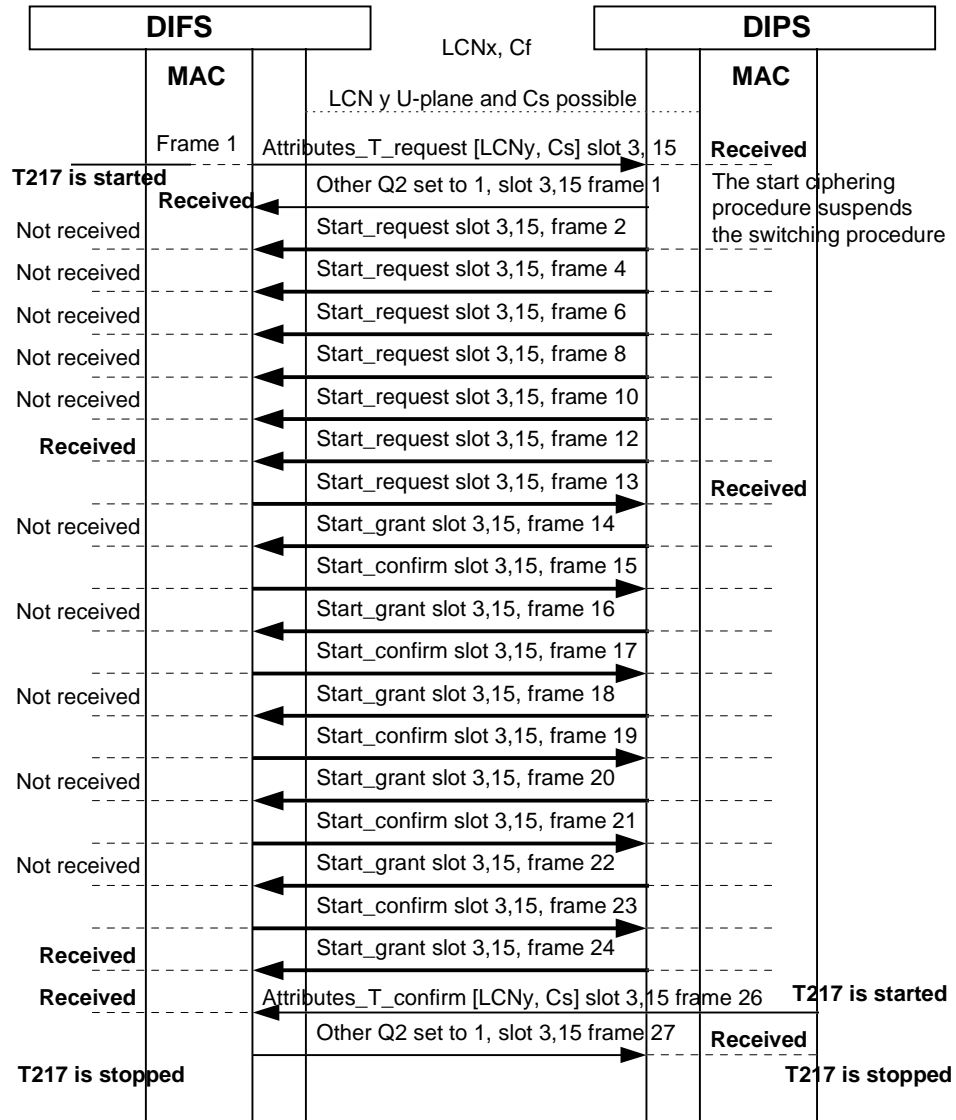

Figure B.6: Collision C_F to C_S and ciphering

As indicated in the scenario, the C_F to C_S switching procedure due to a collision with the MAC layer ciphering procedure, takes, in the worst case, 27 frames(4.32s) to be completed. This long duration could not be a problem when DIFS switches from C_F to C_S but could be a big limitation if this worst case is applied to a C_S to C_F switching procedure: in this case the DIFS or the DIPS needs the C_F channel and this channel could be available only after about 4s.

Solution:

The MAC layer ciphering scenario is stopped until the dynamic switching scenario is completed.

This could be done by the DIFS at the network layer: the DIFS does not start the network layer ciphering procedure if has already started the dynamic switching procedure. This solution solves the problem only for the dynamic switching procedure DIFS initiated but does not solve the problem for the switching procedure DIPS initiated. In the latter case, the DIFS knows the DIPS requirement only after the MAC layer scenario has already been started, anyhow the MAC layer ciphering scenario could be suspended by the DIPS until the switching scenario is ended.

B.2 LU service switch

B.2.1 General

This annex contains some observations and proposals regarding the collisions scenarios between LU1 to LU7 switching procedure.

B.2.2 Switching from LU1 to LU7: bearer handover collision

The MAC layer procedure proposed to switch from an LCNx connection full slot to an LCNx connection double slot is the connection handover procedure. The connection handover procedure cannot be stopped by a bearer handover procedure for the same connection.

When the LLME is informed by the Network layer that a switching LU1 to LU7 is required for the connection LCNx (reception of the CC_SERVICE_CHANGE message), all the new bearer handover requests for the connection LCNx shall be refused until the switching procedure ends. If a bearer handover has already been started it shall be completed before starting the connection handover used for the switching. After the bearer handover is finished the connection handover for the switching could start immediately.

Figure B.7 describes a possible scenario:

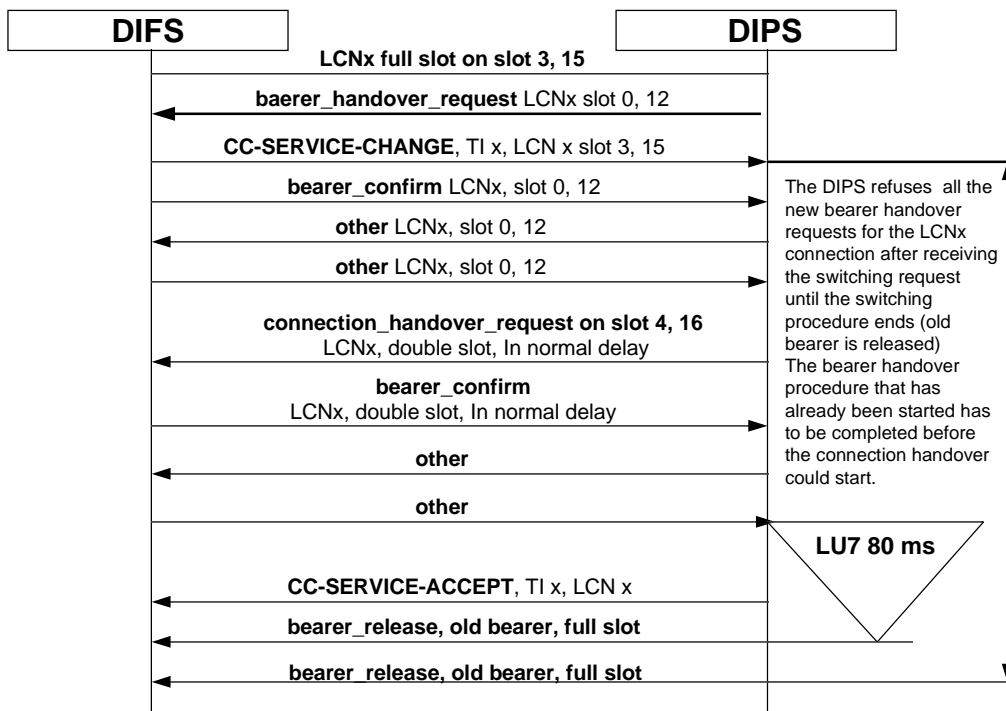

Figure B.7: Collision LU1 - LU7 and bearer handover

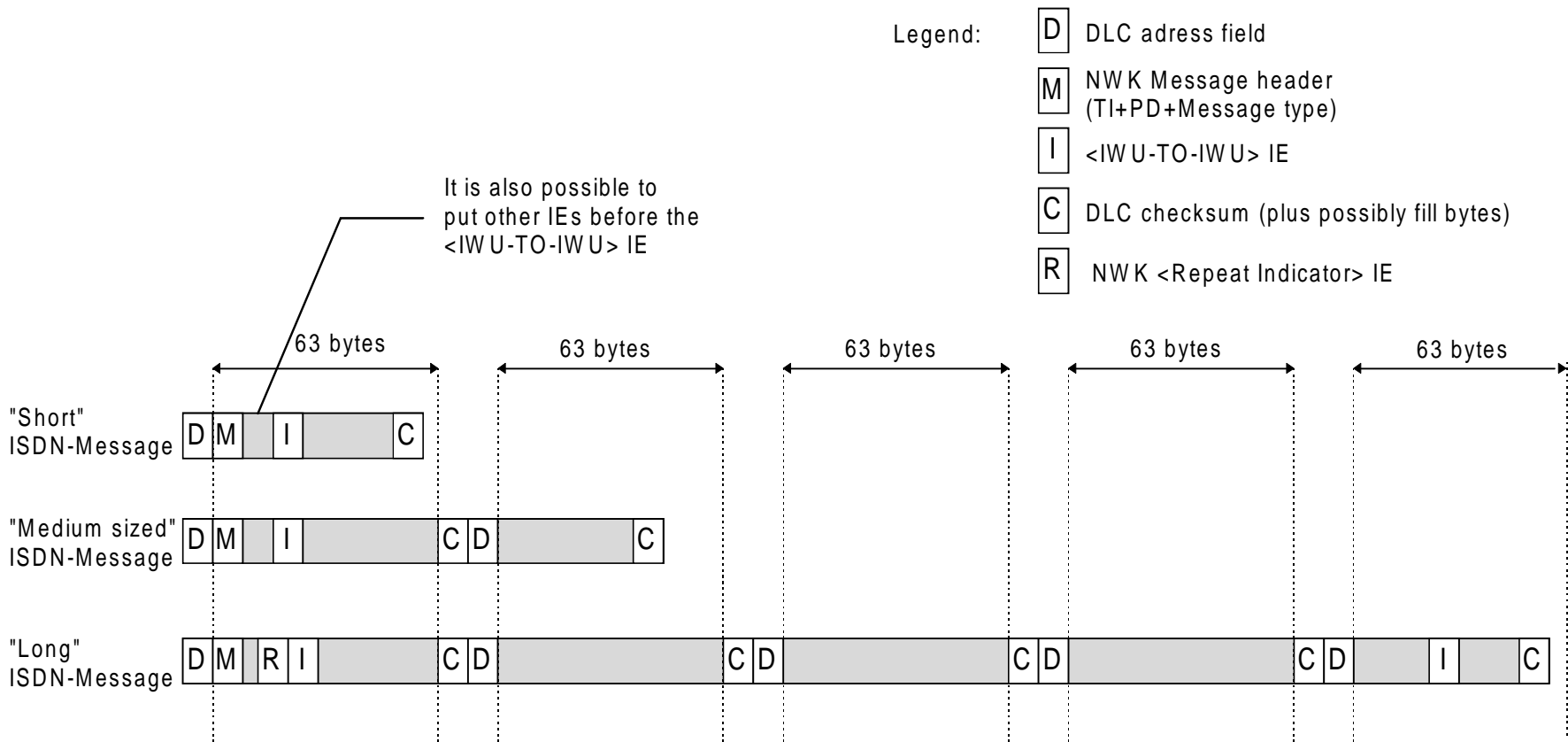

Figure C.1: Examples for segmentation of ISDN messages

History

Document history	
February 1997	Public Enquiry PE 9726: 1997-02-28 to 1997-06-27