



INTERIM
EUROPEAN
TELECOMMUNICATION
STANDARD

DRAFT
pr I-ETS 300 811

November 1996

Source: ETSI TC-TM

Reference: DI/TM-03065

ICS: 33.020

Key words: B-ISDN, UNI, ATM, access, interface, transmission

**Transmission and Multiplexing (TM);
Broadband Integrated Services Digital Network (B-ISDN);
Transmission Convergence (TC) and
Physical Media Dependent (PMD) sublayers
for the S_B reference point at a bit-rate of 25,6 Mbit/s
over twisted pair cable**

ETSI

European Telecommunications Standards Institute

ETSI Secretariat

Postal address: F-06921 Sophia Antipolis CEDEX - FRANCE

Office address: 650 Route des Lucioles - Sophia Antipolis - Valbonne - FRANCE

X.400: c=fr, a=atlas, p=etsi, s=secretariat - **Internet:** secretariat@etsi.fr

Tel.: +33 4 92 94 42 00 - Fax: +33 4 93 65 47 16

Copyright Notification: No part may be reproduced except as authorized by written permission. The copyright and the foregoing restriction extend to reproduction in all media.

© European Telecommunications Standards Institute 1996. All rights reserved.

Contents

Foreword		5
1	Scope	7
2	Normative references	7
3	Definitions and abbreviations	8
3.1	Definitions	8
3.2	Abbreviations	8
4	Physical medium characteristics at the S _B reference point for 25,6 Mbit/s Physical Layer interface.....	9
4.1	Transmission link requirements.....	9
4.1.1	Line and bit rates.....	9
4.1.2	Bit rate symmetry	9
4.1.3	Bit Error Ratio (BER).....	9
4.1.4	Transmission link timing.....	9
4.1.5	Free running timing configurations.....	10
4.2	Transmitter requirements	10
4.2.1	Transmitter zero-crossing distortion.....	11
4.2.1.1	Duty cycle distortion.....	11
4.2.1.2	Edge jitter.....	11
4.2.2	Transmitter waveshapes	11
4.2.3	Transmitter Launch Amplitude (TLA).....	17
4.2.4	Transmitter Return Loss (TRL)	17
4.3	Receiver requirements.....	17
4.3.1	Receiver Acquisition Timing (RAT)	17
4.3.2	Receiver Return Loss (RRL)	17
4.4	Copper link segment characteristics.....	17
4.4.1	100 Ω copper link segment	18
4.4.1.1	100 Ω UTP link segment specifications	18
4.4.1.2	Channel reference model configuration for 100 Ω UTP systems	18
4.4.1.3	Examples of 100 Ω UTP compliant channels	18
4.4.1.4	100 Ω UTP attenuation	18
4.4.1.5	100 Ω UTP NEXT loss	19
4.4.1.6	Characteristic impedance and Structural Return Loss (SRL)	19
4.4.1.7	100 Ω connecting hardware	19
4.4.1.8	UTP Media Interface Connector (MIC).....	19
4.4.2	120 Ω link segment characteristics	20
4.4.2.1	120 Ω link segment specifications	20
4.4.2.2	Channel reference model configuration for 120 Ω systems	20
4.4.2.3	Examples of 120 Ω compliant channels	21
4.4.2.4	120 Ω connecting hardware and Media Interface Connector (MIC).....	21
4.4.3	150 Ω link segment characteristics.....	21
4.4.3.1	150 Ω STP link segment specifications.....	21
4.4.3.2	Channel reference model configuration for 150 Ω STP systems	21
4.4.3.3	Examples of 150 Ω STP compliant channels	22
4.4.3.4	STP Media Interface Connector (MIC).....	22
5	Functions provided by the transmission convergence sublayer.....	22
5.1	Cell scrambling and descrambling.....	23

5.1.1	PRNG sequence.....	25
5.2	4B5B block coding and decoding.....	25
5.2.1	Symbol-pair level code structure	26
5.2.2	Cell delineation	26
5.2.3	Support for a timing signal.....	27
5.3	NRZI encoding and decoding.....	28
5.4	HEC generation and verification.....	28
Annex A (informative): Bibliography		29
History		30

Foreword

This draft Interim European Telecommunication Standard (I-ETS) has been produced by the TM Technical Committee of the European Telecommunications Standards Institute (ETSI), and is now submitted for the Public Enquiry phase of the ETSI standards approval procedure.

This I-ETS defines a 25,6 Mbit/s physical layer interface to be applied to the S_B reference point of the reference configurations of the B-ISDN customer access as defined in ITU-T Recommendation I.414 [2] for B-ISDN applications. It addresses separately the Physical Media Dependent (PMD) and Transmission Convergence (TC) sublayers used at this interface.

This I-ETS has been produced taking into account the recommendations given in ITU-T Recommendations I.413 [3] and I.432 [4].

Proposed announcement date	
Date of latest announcement of this I-ETS (doa):	3 months after ETSI publication

Blank page

1 Scope

This Interim European Telecommunication Standard (I-ETS) defines a 25,6 Mbit/s physical layer interface to be applied at the S_B reference point of the reference configurations of the Broadband Integrated Services Digital Network (B-ISDN) customer access as defined in ITU-T Recommendation I.414 [2]. The physical layer is divided into a Physical Media Dependent (PMD) sublayer and a Transmission Convergence (TC) sublayer. The PMD sublayer provides the definitions for the transmitter, the receiver, timing recovery, media interface connector and the channel transmission media. The TC sublayer defines the line coding, scrambling, data framing and synchronization.

Transmission Convergence (TC) sublayer	HEC generation/verification cell scrambling/descrambling line coding/decoding cell delineation
Physical Media Dependent (PMD) sublayer	bit timing physical media connectors

Figure 1: Functions of the TC and PMD sublayers

The bit rate used throughout this document refers to the logical information rate, before line coding. The term line symbol rate will be used when referring to the rate after line coding (25,6 Mb/s bit rate results in a 32 Mbaud line symbol rate after 4B5B encoding).

2 Normative references

This I-ETS incorporates by dated and undated reference, provisions from other publications. These normative references are cited at the appropriate places in the text and the publications are listed hereafter. For dated references, subsequent amendments to or revisions of any of the publications apply to this I-ETS only when incorporated in it by amendment or revision. For undated references the latest edition of the publication referred to applies.

- [1] ITU-T Recommendation I.113 (1993): "Vocabulary of terms for broadband aspects of ISDN".
- [2] Draft ITU-T Recommendation I.414 (1995): "Overview of Recommendations on layer 1 for ISDN and B-ISDN customer access".
- [3] ITU-T Recommendation I.413 (1993): "B-ISDN user-network interface".
- [4] ITU-T Recommendation I.432 (1993): "B-ISDN user-network interface - Physical layer specifications".
- [5] EIA/TIA 568 A 95 (1995): "Commercial Building Telecommunications Cabling Standard".
- [6] ISO/IEC 11801 (1995): "Information Technology - Generic cabling for customer premises".
- [7] IEC/603-7 (1990): "Connectors for frequencies below 3MHz for use with printed boards - Part 7: Detail specification for connectors, 8-way, including fixed and free connectors with common mating features".
- [8] EN 50173 (1995): "Information Technology - Generic cabling systems".

3 Definitions and abbreviations

3.1 Definitions

For the purposes of this I-ETS, the definitions given in ITU-T Recommendation I.113 [1] apply.

3.2 Abbreviations

For the purposes of this I-ETS, the following abbreviations apply:

ac	alternating current
ATM	Asynchronous Transfer Mode
BER	Bit Error Ratio
B-ISDN	Broadband Integrated Services Digital Network
FTP	Foiled Twisted Pair
HEC	Header Error Control
MIC	Media Interface Connector
NEXT	Near End Cross Talk
NRZI	Non-Return to Zero Inverted
PLL	Phase-Lock Loop
PMD	Physical Media Dependent
PRNG	Pseudo Random Number Generator
RAT	Receiver Acquisition Time
RRL	Receiver Return Loss
SRL	Structural Return Loss
STP	Shielded Twisted Pair
TC	Transmission Convergence
TDCD	Transmitter Duty Cycle Distortion
TEJ	Transmitter Edge Jitter
TLA	Transmitter Launch Amplitude
TRL	Transmitter Return Loss
UNI	User Network Interface
UTP	Unshielded Twisted Pair
4B5B	4 Bit / 5 Bit line coding mechanism

4 Physical medium characteristics at the S_B reference point for 25,6 Mbit/s Physical Layer interface

4.1 Transmission link requirements

4.1.1 Line and bit rates

The line symbol rate shall be 32 Mbaud \pm 100 ppm. Due to the use of the 4B5B block code, the bit rate is 25,6 Mbit/s \pm 100 ppm.

4.1.2 Bit rate symmetry

Interfaces shall be symmetric; i.e., the bit rates shall be the same in both transmit and receive directions.

4.1.3 Bit Error Ratio (BER)

The active input interface shall operate at a BER not to exceed 1×10^{-10} when presented with a transmitter specified in subclause 4.2, transmitted through the channel reference model described in subclause 4.4 in the presence of the worst-case crosstalk noise specified in subclause 4.4.

4.1.4 Transmission link timing

Figure 2 illustrates the conceptual components of the TC/PMD and the timing source.

The TC/PMD shall use a local crystal oscillator or a distributed low jitter timing reference that supports a nominal transmission rate of 25,6 Mbit/s.

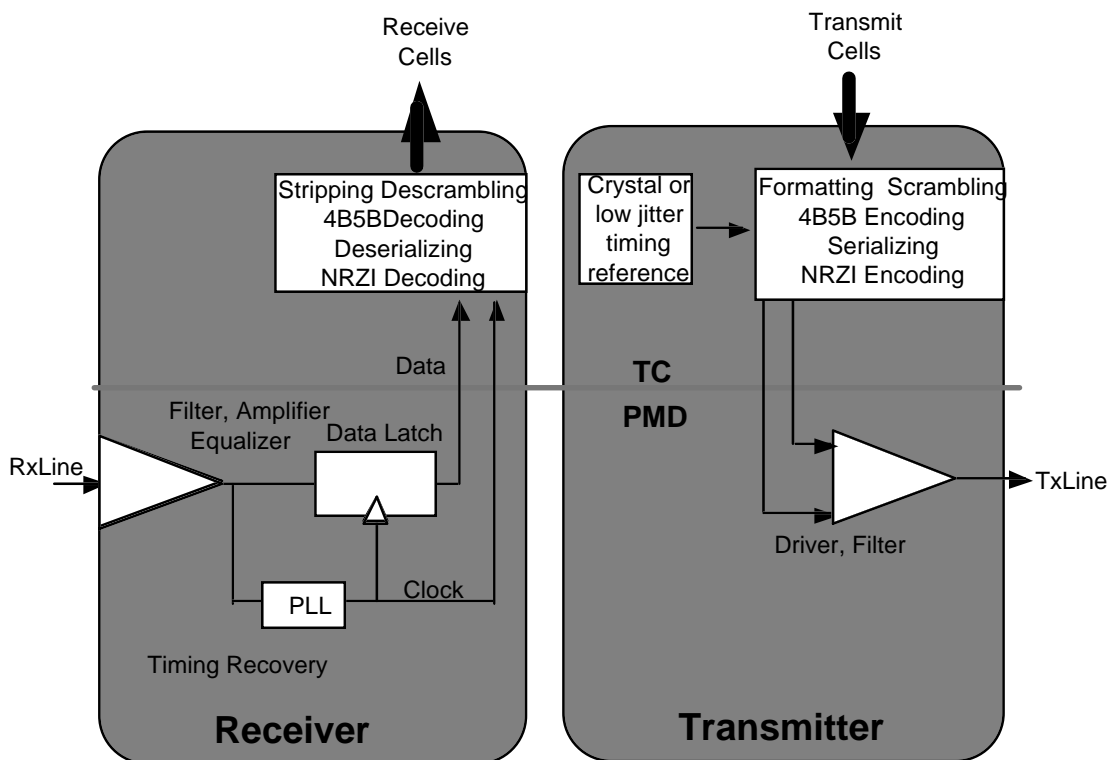

Figure 2: Illustration of example TC/PMD components and transmitter timing

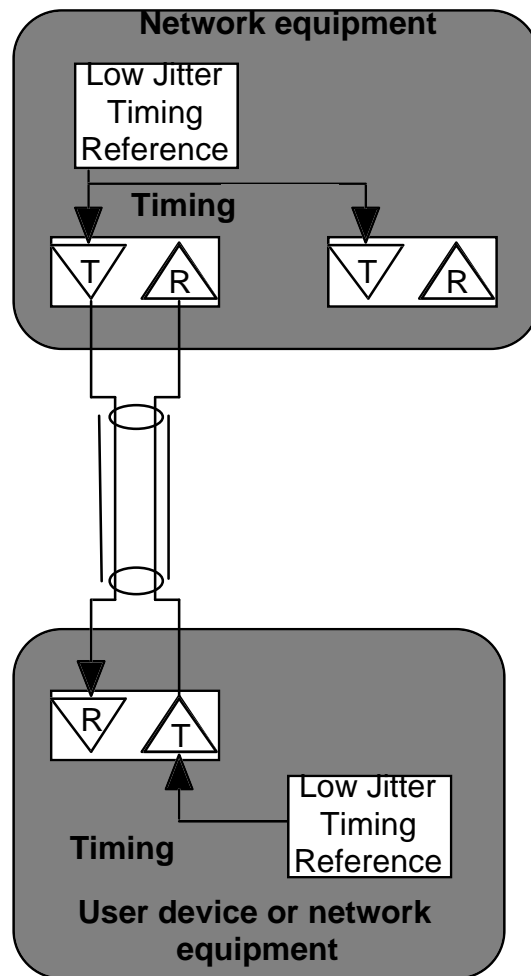

Figure 3: User device—network equipment timing configurations

4.1.5 Free running timing configurations

The recommended approach is to use point to point timing where the transmit clocks on each end of a link are independent. Under these conditions, the pulse waveform templates of subclause 4.2.2 bound the acceptable pulse shapes to be found on any link.

4.2 Transmitter requirements

These specifications place requirements on the transmitted signal. Measurement to these specifications will require that a means exists to send unscrambled, unencoded data streams at the line symbol rate through the transmitter circuitry.

For all transmitter measurements, the transmitter shall be terminated in a 100 Ω resistive load for 100 Ω UTP specifications.

The transmitter shall be terminated in a 150 Ω resistive load for 150 Ω Shielded Twisted Pair (STP) specifications.

The transmitter shall be terminated in a 120 Ω resistive load for 120 Ω specifications.

Unless specified separately, the parameters specified below apply to all of the 100, 120, and 150 Ω measurements.

4.2.1 Transmitter zero-crossing distortion

These specifications limit the distortion of the transmitted data edge zero-crossings relative to the transmit clock. Duty cycle distortion is intended to measure the static, non-data-dependent distortion in the data

edge zero-crossings typically caused by asymmetrical propagation or rise/fall times of transmitter logic or in the conversion from a single-ended to a differential data stream. Edge jitter is intended to measure the dynamic and data dependent distortion in the data edge zero-crossings typically caused by transmit filtering and noises internal and external to the transmitter circuitry.

4.2.1.1 Duty cycle distortion

Duty cycle distortion is specified for the transmitted data stream shown below and is defined as one half the difference in the positive and negative pulse widths of the alternating current (ac) coupled transmitter wave form.

NOTE: The wave form specified below is only a test wave form for the purpose of measuring the launch amplitude and should not be construed as a wave form seen during normal operation of the physical layer.

The Transmitter Duty Cycle Distortion (TDCD) shall be less than 1,5 ns peak when the output is clocked by a local clock source:

Two test wave forms (symbol elements at line symbol rate) are defined to be: 00110011.... , and 01010101... These waveforms are described as would be found on the wire (i.e., following all scrambling, and 4B5B and Non-Return to Zero Inverted (NRZI) encoding).

4.2.1.2 Edge jitter

Edge jitter is specified for any wave form compliant with the scrambling and encoding specifications in clause 5. It is defined as the maximum of the peak variation of the rising edges of data relative to the transmit clock and the falling edges of data relative to the transmit clock.

The Transmitter Edge Jitter (TEJ) shall be less than 4 ns peak-to-peak when the output is clocked by a local clock source.

4.2.2 Transmitter waveshapes

The transmitter wave shape shall conform to the waveform templates defined in tables 1, 2, 3, 4 and 5 below. An additional constraint shall be that the worst case 3dB corner frequency of the transmitter output shall be less than or equal 12 kHz.

The table and figure pairs below list and then plot the data points that define the pulse templates.

NOTE: Amplitude is expressed as the measured pulse amplitude normalized such that the value one on each graph represents the amplitude of the fundamental frequency for the single symbol element. Time is expressed in percent of the measured pulse width. With a line symbol rate of 32 Mbaud, the nominal line symbol width is 31,25 ns. (Therefore, for example, the nominal duration - corresponding to the 100 % mark - for the five-symbol element is 156,25 ns).

Table 1: Template for five symbol element waveform

Point	Upper time (%)	Upper amplitude	Lower time (%)	Lower amplitude
A	-0,3	0	0,3	0
B	6,3	1,20	10,5	0,90
C	14	1,20	23,0	0,50
D	23	1,05	36,0	0,75
E	34	1,20	53,0	0,60
F	56	0,95	87,0	0,60
G	95	0,92	99,7	0
H	100,3	0	-	-

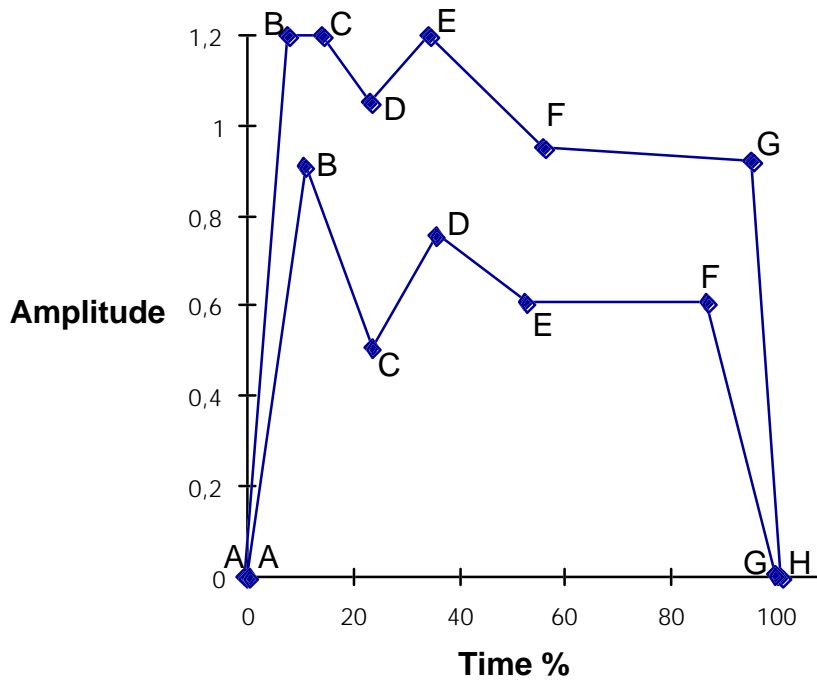

Figure 4: Pulse template for table 1,
 five symbol element waveform

Table 2: Template for four symbol element waveform

Point	Upper time (%)	Upper amplitude	Lower time (%)	Lower amplitude
A	-0,4	0	0,4	0
B	7,9	1,20	13,1	0,90
C	17	1,20	28,0	0,50
D	29	1,05	45,0	0,75
E	43	1,20	66,0	0,60
F	70	0,95	84,0	0,60
G	93,5	0,92	99,6	0
H	100,4	0	-	-

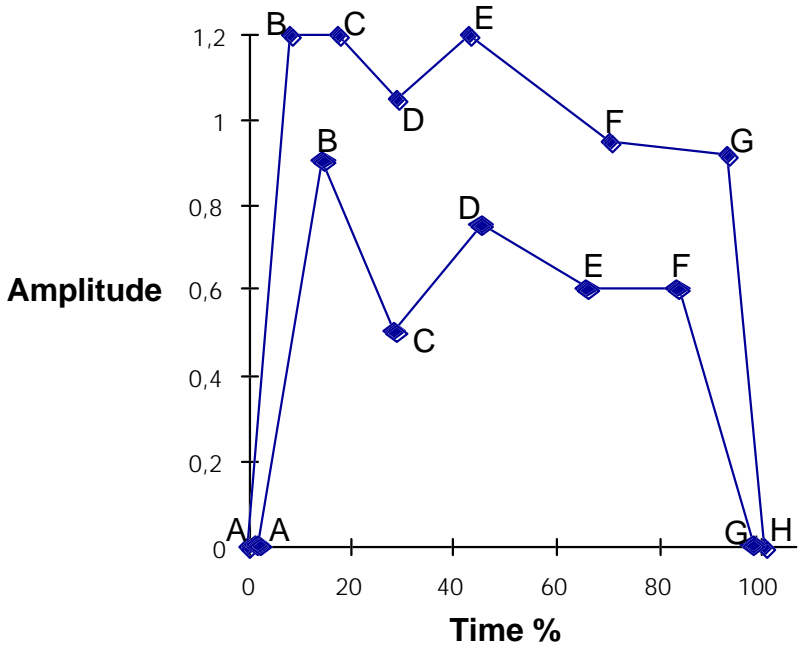

Figure 5: Pulse template for table 2, four symbol element waveform

Table 3: Template for three symbol element waveform

Point	Upper time (%)	Upper amplitude	Lower time (%)	Lower amplitude
A	-0,5	0	0,5	0
B	10,5	1,20	17,5	0,90
C	23,0	1,20	37,5	0,50
D	38,0	1,05	59,5	0,75
E	57,0	1,20	87,5	0,6
F	93,0	0,95	99,5	0
G	100,5	0	-	-

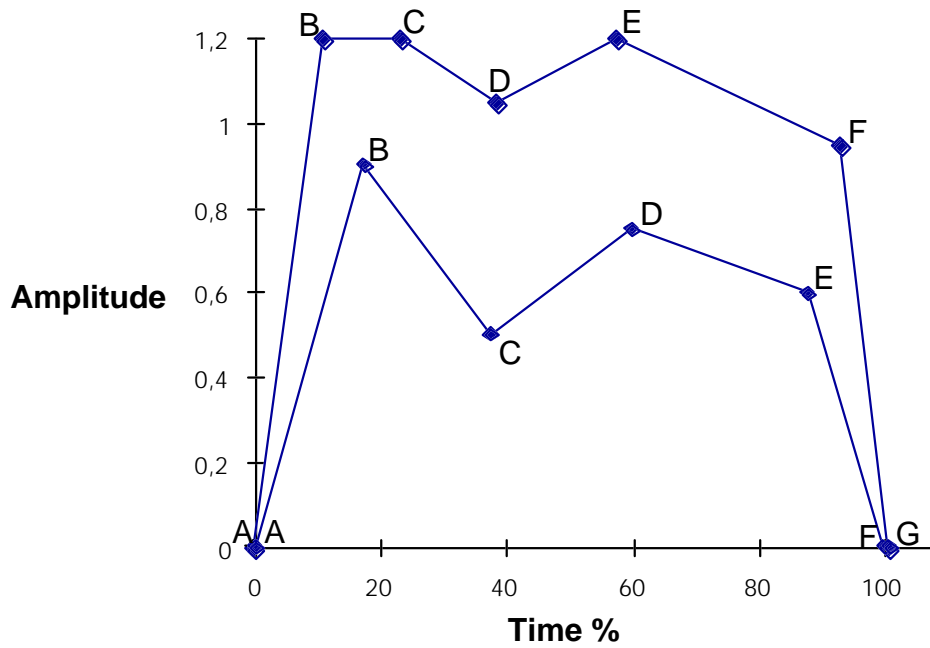

Figure 6: Pulse template for table 3,
 three symbol element waveform

Table 4: Template for two symbol element waveform

Point	Upper time (%)	Upper amplitude	Lower time (%)	Lower amplitude
A	-1,0	0	1,0	0
B	15,5	1,20	26,0	0,90
C	34,5	1,20	57,0	0,50
D	56,5	1,05	81,5	0,65
E	85,0	1,20	99,0	0
F	101,0	0	-	-

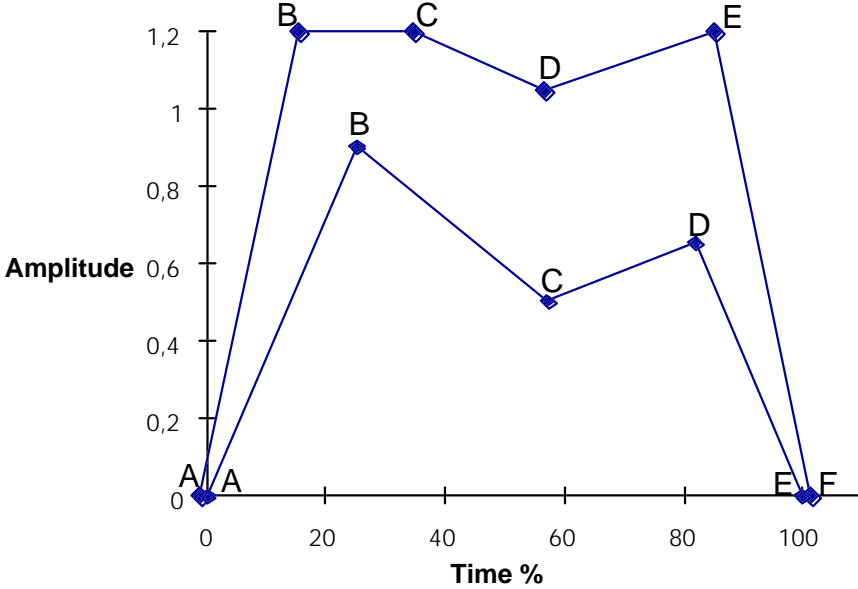

Figure 7: Pulse template for table 4, two symbol waveform

Table 5: Template for one symbol element wave form

Point	Upper time (%)	Upper amplitude	Lower time (%)	Lower amplitude
A	-1,5	0	1,5	0
B	23,5	0,83	26,0	0,55
C	48,5	1,15	51,5	0,95
D	80,0	0,86	77,5	0,52
E	101,5	0	98,5	0

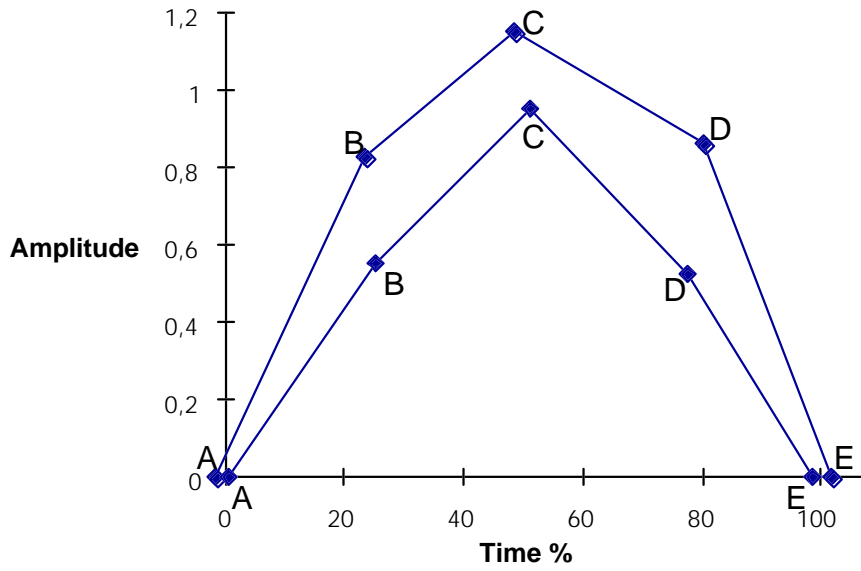

Figure 8: Pulse template for table 5,
one symbol element waveform

4.2.3 Transmitter Launch Amplitude (TLA)

Transmitter Launch Amplitude (TLA) is specified for the transmitted data stream shown below and is defined as the peak-to-peak amplitude of the transmitted wave form.

The test wave form (symbol elements at line symbol rate) is defined to be: 01010101....The TLA shall be between the values specified below:

- 100 Ω Unshielded Twisted Pair (UTP): $2,7 < TLA < 3,4$ V peak-to-peak;
- 150 Ω (STP): $3,3 < TLA < 4,2$ V peak-to-peak;
- 120 Ω : $2,95 < TLA < 3,75$ V peak-to-peak.

4.2.4 Transmitter Return Loss (TRL)

Transmitter Return Loss (TRL) is specified for a transmitter which is actively transmitting any wave form compliant with the scrambling and encoding specifications in clause 5.

The TRL shall be greater than the values specified in table 6 across the full allowed range of characteristic impedance (according to the media type).

Table 6: Transmitter Return Loss

Frequency range	Return loss
1-6 MHz	14 dB
6-17 MHz	12 dB
17-25 MHz	8 dB

4.3 Receiver requirements

4.3.1 Receiver Acquisition Timing (RAT)

The receiver shall acquire phase lock in the presence of a BER of less than 1×10^{-10} with a Receiver Acquisition Time (RAT) of less than 50 ms when provided with a valid signal.

A valid signal is defined as a signal from a transmitter compliant with subclause 4.2 and scrambled and encoded as defined in clause 5 which has been sent through a channel that complies with subclause 4.4.

4.3.2 Receiver Return Loss (RRL)

The Receiver Return Loss (RRL) shall be greater than the values specified in table 7 across the full allowed range of characteristic impedance (according to the media type).

Table 7: Receiver Return Loss

Frequency Range	Return Loss
1-17 MHz	15 dB
17-25 MHz	8 dB

4.4 Copper link segment characteristics

The copper link segment consists of one or more sections of twisted pair copper cable media containing two or four pairs along with intermediate connectors required to connect sections together and terminated at each end in the specified electrical data connector. The cable is interconnected to provide two continuous electrical paths which are connected to the interface port at each end. The transmitter and receiver requirements are specified for the media defined below. The implementation specified is for the horizontal distribution of the cable plant and extends from the telecommunications closet to the work area. The copper link segment is defined for 100 Ω UTP, 120 Ω , and 150 Ω STP cabling systems.

In this subclause, the EN 50173 [8] can be used interchangeably with the ISO/IEC 11801 [6] from which it has been derived.

4.4.1 100 Ω copper link segment

This subclause defines the cabling and connector conditional requirements when a 100 Ω cable/connector system is deployed. These requirements define the *minimum* requisites for a compliant and functional system. Note that as long as 100 Ω components are used consistently, a specification of category 3 unshielded cable and connectors allows for the optional use of higher grade components (e.g., category 4, category 5) and the optional use of cable and/or connector shields.

4.4.1.1 100 Ω UTP link segment specifications

The electrical parameters important to link performance are attenuation, Near End CrossTalk loss (NEXT loss), characteristics impedance, and Structural Return Loss (SRL).

All components comprising a link segment shall meet or exceed all of the requirements for category 3 as specified by EIA/TIA 568 A 95 [5] and ISO/IEC 11801 [6].

The composite channel attenuation shall meet or exceed the category 3 attenuation performance limits defined in annex E of EIA/TIA 568 A 95 [5].

The composite channel NEXT loss shall meet or exceed the category 3 NEXT loss performance limits defined in annex E of EIA/TIA 568 A 95 [5].

4.4.1.2 Channel reference model configuration for 100 Ω UTP systems

The channel reference model for a category 3 UTP system is defined to be a link consisting of 90 m of category 3 UTP cable, 10 m of category 3 flexible cords, and four category 3 connectors internal to the link.

4.4.1.3 Examples of 100 Ω UTP compliant channels

Since the link segment requirements for attenuation and NEXT loss are derived from the electrical performance of the channel reference model, the channel reference model (properly installed) defines a compliant link. Additionally, properly installed link segments consisting of no more than 90 m of category 3 UTP cable, no more than 10 m of category 3 flexible cords, and no more than four category 3 connectors internal to the link are examples of compliant links.

However, any installed link consisting of category 3 components and meeting the link attenuation and NEXT loss requirements of subclause 4.4.1.1 is compliant.

In many situations it is also possible to trade off attenuation for NEXT loss and derive links which may differ from the topology of the channel reference model but still have acceptable performance. The number of potential trade-offs is quite large and this subject is beyond the scope of this I-ETS.

4.4.1.4 100 Ω UTP attenuation

Attenuation describes the loss in signal level as a signal propagates along a homogeneous medium such as a cable or cord.

The cable used in constructing a link shall meet or exceed the horizontal category 3 UTP cable attenuation requirements of section 10 of EIA/TIA 568 A 95 [5] and clause 8 of ISO/IEC 11801 [6].

The cordage used in constructing flexible cords and patch cables shall meet or exceed the attenuation requirements for category 3 flexible cordage specified in section 10 of EIA/TIA 568 A 95 [5].

In general, the per unit length attenuation limits for cordage are 20 % higher than those allowed for horizontal cables.

4.4.1.5 100 Ω UTP NEXT loss

NEXT loss defines the amount of unwanted signal coupling between distinct pairs of multi-pair cable. It is the result of parasitic capacitive and inductive coupling between the various conductors comprising a cable.

The cable and cordage used in constructing a link shall meet or exceed the horizontal category 3 UTP cable NEXT requirements of section 10 of EIA/TIA 568 A 95 [5] and clause 8 of ISO/IEC 11801 [6].

4.4.1.6 Characteristic impedance and Structural Return Loss (SRL)

Characteristic impedance is the ratio of voltage to current of a wave propagating along one direction in a uniform transmission line. When a transmission line is not completely uniform in construction, the characteristic impedance may exhibit slight variations as a function of length. This variation is measured by a quantity defined as Structural Return Loss (SRL). It is a measure of the deviation of characteristic impedance from a nominal value in a transmission line which is not perfectly homogeneous.

Both the characteristic impedance and SRL of cables and cords used in construction of a link shall meet the requirements specified for 100 Ω category 3 in section 10 of EIA/TIA 568 A 95 [5] and clause 8 of ISO/IEC 11801 [6].

4.4.1.7 100 Ω connecting hardware

The electrical performance of connecting hardware can be critical to the overall performance of a transmission channel. In general, the electrical parameters specified for connecting hardware are attenuation, NEXT loss, and return loss.

All connecting hardware used within this PMD channel (outlets, transition connectors, patch panels, and cross-connect fields) shall meet or exceed the category 3 electrical requirements for attenuation, NEXT loss, and return loss specified in section 10 of EIA/TIA 568 A 95 [5] and clause 9 of ISO/IEC 11801 [6].

All measurements on connecting hardware shall be conducted in accordance with the procedures described in annex B of EIA/TIA 568 A 95 [5] and annex A.2 of ISO/IEC 11801 [6]. These requirements apply to all individual UTP connectors, including patch panels, transition connectors, cross-connect fields, and telecommunication outlets.

The connector termination practices and UTP cable practices described in section 10 of EIA/TIA 568 A 95 [5] shall be followed.

4.4.1.8 UTP Media Interface Connector (MIC)

Each end of the category 3 UTP link segment shall be terminated with MIC specified in IEC 603-7 [7] (commonly referred to as RJ-45). This connector is an 8-contact modular jack/plug, and the mated combination shall meet the requirements of subclause 4.4.1.7.

The cable assembly shall connect the corresponding contacts of the plugs at either end of the link (i.e., Pin 1 to Pin 1, Pin 2 to Pin 2, etc.).

This ensures that the cable assembly is a straight through (no crossover) cable and that the polarity of the assembly is maintained.

The UTP-MIC shall be an 8-contact receptacle (jack) as specified in ISO/IEC 603-7 [7], that is attached to the ATM user device and ATM network equipment.

The contact assignments for the UTP-MIC receptacle (jack) shall be as listed in table 8.

Table 8: Contact assignments for UTP-MIC jack

Contact	Signal at the ATM user device	Signal at the ATM network equipment
1	Transmit +	Receive +
2	Transmit –	Receive –
3	Unused	Unused
4	Unused	Unused
5	Unused	Unused
6	Unused	Unused
7	Receive +	Transmit +
8	Receive –	Transmit –

4.4.2 120 Ω link segment characteristics

This subclause defines the cabling and connector conditional requirements when a 120 Ω cable/connector system is deployed. These requirements define the *minimum* requisites for a compliant and functional system. Note that as long as 120 Ω components are used consistently, a specification of category 4 unshielded cable and connectors allows for the optional use of higher grade components (e.g., category 5) and the optional use of cable and/or connector shields.

NOTE: Therefore, that systems commonly called "FTP" (Foiled Twisted Pair) which employ 120 Ω shielded category 5 twisted pair are typically consistent with the requirements in this section.

The 120 Ω cable system connects the transmitter on one end of the link segment to the receiver on the other end of the link segment. The cable system consists of one or more sections of twisted pair cable containing two wire pairs, along with intermediate connectors required to connect sections together. The media interface connector is used to terminate the ends of the fixed wiring. The cable is interconnected to provide two continuous electrical paths between the transmitters and receivers at the endpoints.

4.4.2.1 120 Ω link segment specifications

This section defines the link segment characteristics for 120 Ω link using 120 Ω category 4 cables specified in ISO/IEC 11801 [6] which meets the performance requirements of this system. The channel link requirements are independent of the cable type but have been defined using the attenuation and NEXT loss requirements for category 4 cable. The maximum allowable length of the cable system will vary depending on the quality of the cable, and patch cord(s).

The composite channel attenuation for a 120 Ω link shall meet the attenuation performance limits defined in annex E of EIA/TIA 568 A 95 [5] for category 4 cables.

The composite channel NEXT loss for a 120 Ω link shall meet the NEXT loss performance limits defined in annex E of EIA/TIA 568 A 95 [5] for category 4 cables.

Under these conditions both the characteristic impedance and SRL of cables and cords used in construction of a link shall meet the requirements specified for 120 Ω category 4 in section 10 of EIA/TIA 568 A 95 [5] and clause 8 of ISO/IEC 11801 [6].

4.4.2.2 Channel reference model configuration for 120 Ω systems

A typical cable system includes fixed cable terminated in the media interface connector, and attachment cables for both ends. The per unit length attenuation of an attachment cable is typically allowed to be up to 150 % that of the fixed cable. Refer to ISO/IEC 11801 [6], clause 6 for more detailed information.

The channel reference model for a 120 Ohm system is defined to be a link consisting of 90 m of 120 Ω cable, 10 m of 120 Ω patch cord, and 4 category 4 connectors internal to the link.

4.4.2.3 Examples of 120 Ω compliant channels

Since the link requirements for attenuation and NEXT loss are derived from the electrical performance of the channel reference model, the channel reference model (properly installed) defines a compliant link. A properly installed channel reference model defines a compliant link. Additionally, properly installed links consisting of no more than 90 m of 120 Ω cable, no more than 10 m of 120 Ω patch cord, and no more than four category 4 connectors internal to the link are examples of compliant links. However, any installed link consisting of category 4 components and meeting the link attenuation and NEXT loss requirements of subclause 4.4.2.1 is compliant.

In many situations it is also possible to trade off attenuation for NEXT loss and derive links which may differ from the topology of the channel reference model but still have acceptable performance. The number of potential trade-offs is quite large and this subject is beyond the scope of this document.

4.4.2.4 120 Ω connecting hardware and Media Interface Connector (MIC)

The connecting hardware and MIC defined for 100 Ω link segments shall also apply to 120 Ω systems except that all references to category 3 requirements shall be replaced by category 4.

4.4.3 150 Ω link segment characteristics

The 150 Ω cable system connects the transmitter on one end of the link segment to the receiver on the other end of the link segment. The cable system consists of one or more sections of shielded twisted pair cable containing two wire pairs, along with intermediate connectors required to connect sections together. The media interface connector is used to terminate the ends of the fixed wiring. The cable is interconnected to provide two continuous electrical paths between the transmitters and receivers at the endpoints.

4.4.3.1 150 Ω STP link segment specifications

The system can operate with a variety of STP cable types. EIA/TIA 568 A 95 [5] and ISO/IEC 11801 [6] define STP cables which will meet the performance requirements of this system. The channel link requirements are independent of the cable type but have been defined using the attenuation and NEXT loss requirements for category 3 UTP cable. The maximum allowable length of the cable system will vary depending on the quality of the STP cable, and patch cord(s).

The composite channel attenuation for a 150 Ω STP link shall meet the attenuation performance limits defined in annex E of EIA/TIA 568 A 95 [5] for category 3 UTP cables.

The composite channel NEXT loss for a 150 Ω STP link shall meet the NEXT loss performance limits defined in annex E of EIA/TIA 568 A 95 [5] for category 3 UTP cables.

Under these conditions both the characteristic impedance and structural return loss of cables and cords used in construction of a link shall meet the requirements specified for 150 Ω STP in section 10 of EIA/TIA 568 A 95 [5].

4.4.3.2 Channel reference model configuration for 150 Ω STP systems

A typical cable system includes fixed cable terminated in the media interface connector, and attachment cables for both ends. The per unit length attenuation of an attachment cable is typically allowed to be up to 150 % that of the fixed cable. Refer to ISO/IEC 11801 [6], clause 6 for more detailed information.

The channel reference model for an STP system is defined to be a link consisting of 90 m of STP-A cable, 10 m of STP-A patch cord, and 4 STP-A connectors internal to the link.

4.4.3.3 Examples of 150 Ω STP compliant channels

Since the link requirements for attenuation and NEXT loss are derived from the electrical performance of the channel reference model, the channel reference model (properly installed) defines a compliant link. A properly installed channel reference model defines a compliant link. Additionally, properly installed links consisting of no more than 90 m STP-A cable, no more than 10 m of STP-A patch cord, and no more than 4 STP-A connectors internal to the link are examples of compliant links. However, any installed link consisting of STP components and meeting the link attenuation and NEXT loss requirements of subclause 4.4.3.1 is compliant.

In many situations it is also possible to trade off attenuation for NEXT loss and derive links which may differ from the topology of the channel reference model but still have acceptable performance. The number of potential trade-offs is quite large and this subject is beyond the scope of this document.

4.4.3.4 STP Media Interface Connector (MIC)

Each end of the fixed cable shall be terminated in the STP media interface connector.

The STP media interface connector shall meet all the requirements of the Telecommunications Connector as defined in EIA/TIA 568 A 95 [5], section 11.

The STP media interface connector contact assignments shall be as listed in table 9.

Table 9: Contact assignments for STP-MIC connectors

Contact	Signal at the ATM user device	Signal at the ATM network equipment
B	Transmit +	Receive +
R	Receive +	Transmit +
G	Receive -	Transmit -
O	Transmit -	Receive -

5 Functions provided by the transmission convergence sublayer

At the physical level of the interface, at the SB reference point, the bit rate shall be 25,6 Mbit/s. The maximum bit rate available for user information cells, signalling cells and ATM and higher layers OAM information cells, excluding the "Start Of Cell" commands, is 25,125 Mbit/s.

The functions of the TC sublayer are:

- scrambling and descrambling;
- 4B5B block encoding and decoding (including command codes) which provides the means for:
 - cell delineation and scrambler/descrambler reset;
 - support of a periodic timing signal for isochronous services.
- NRZI encoding and decoding;
- HEC generation and verification.

Figure 9 is a block diagram of the TC sublayer that identifies the above functions and their data flow relationships.

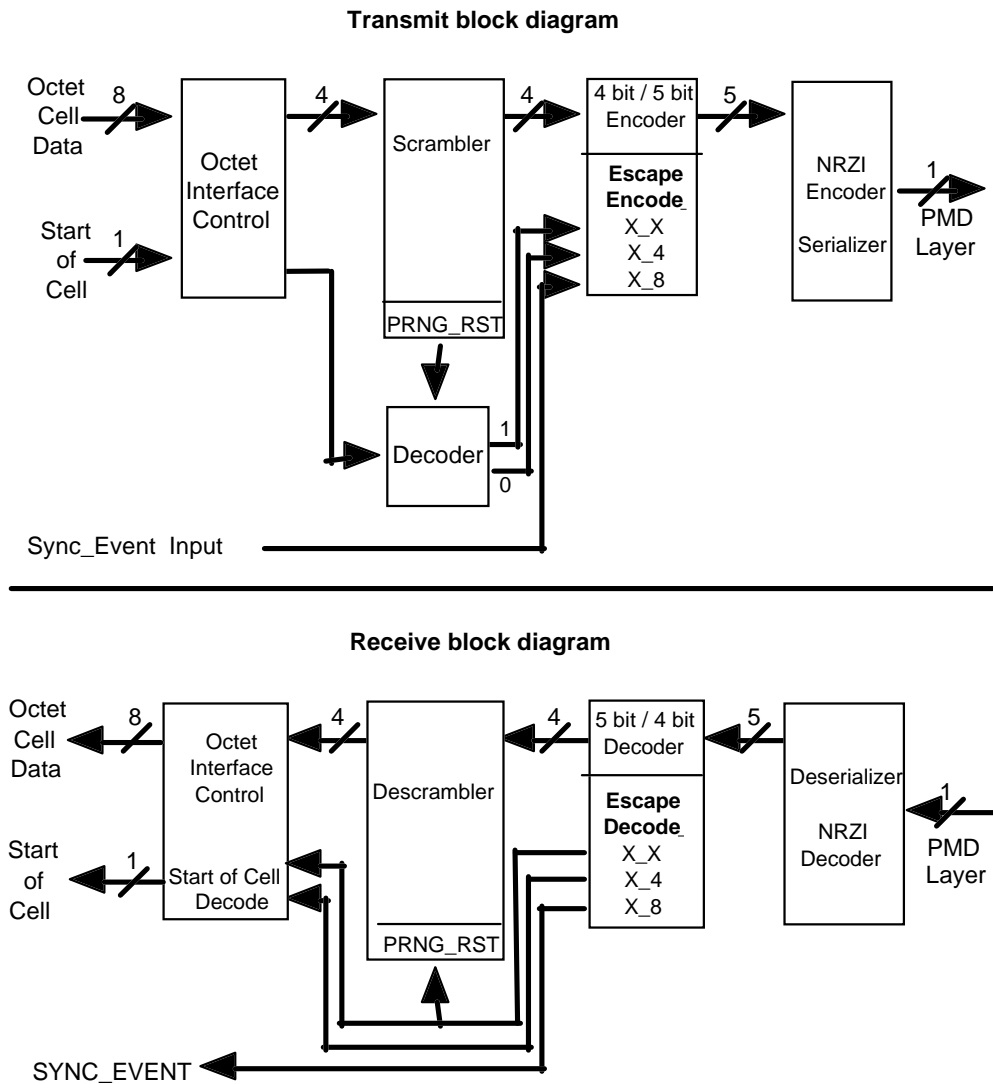

NOTE: This figure is for information only - not intended as a required implementation.

Figure 9: Block diagrams of the TC sublayer

5.1 Cell scrambling and descrambling

To provide the appropriate frequency distribution of the electrical signal across the line, the data octets shall be scrambled before transmission.

All 53 octets of the ATM cell shall be scrambled and encoded prior to transmission.

The scrambler and the de-scrambler are each comprised of a 10-bit PRNG (Pseudo-Random Number Generator). The PRNG is based on the following polynomial:

$$x^{10} + x^7 + 1$$

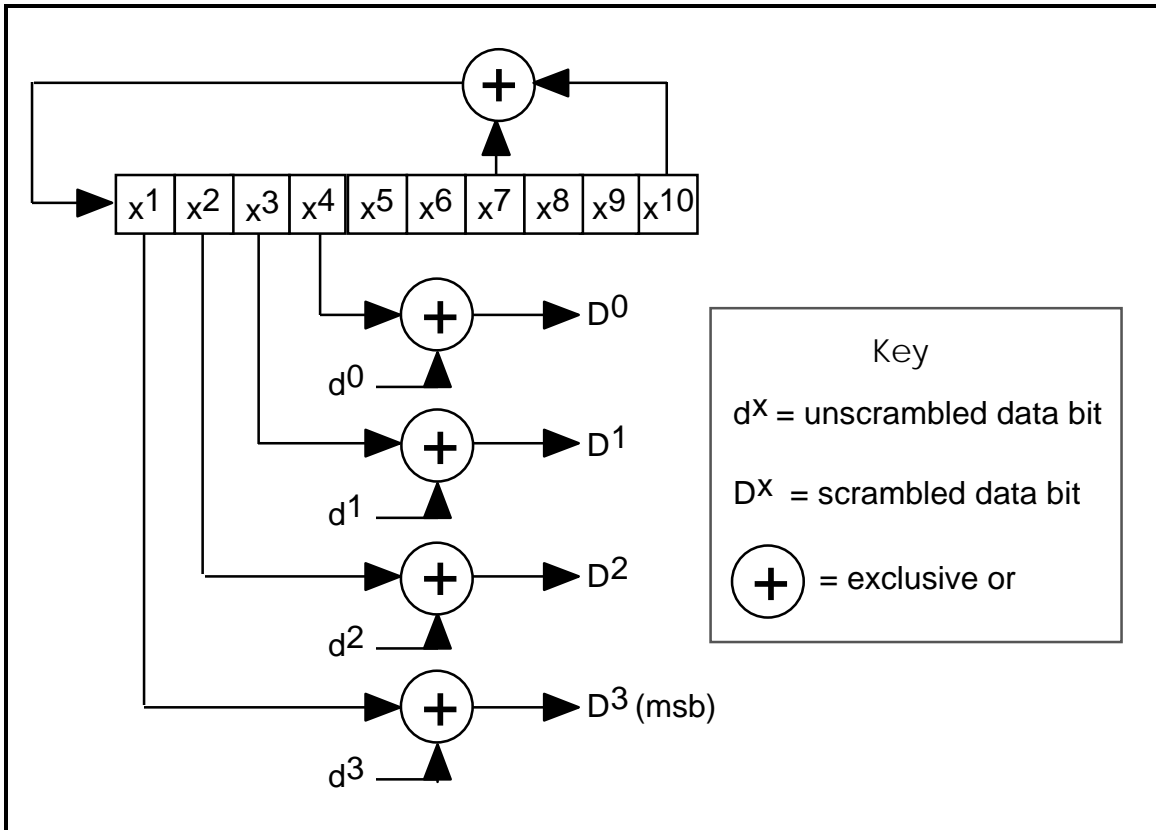

NOTE: For information only—not intended to depict a required implementation.

Figure 10: Pseudo Random Number Generator (PRNG) block diagram

The PRNG shall be clocked four times after each nibble regardless of whether the command octet, valid data or idle data is being transmitted. Command octets shall not be scrambled.

The scrambler/de-scrambler shall be implemented such that each successive data nibble (starting with the high order nibble and high order bit within each nibble) is XORed with the corresponding 4 bits of the PRNG ($x^1 x^2 x^3 x^4$ as illustrated in figure 10) each nibble cycle (4 x bit cycle time).

The PRNG shall be reset to its initial state ('3FF'x) upon every detection of two consecutive escape ('X') nibbles, whether or not these escape nibbles are octet-aligned (i.e. form a start-of-cell X_X sequence). The first nibble after the two consecutive escape nibbles shall then be XORed with the initial 'F' of the scrambler sequence, unless it is part of a command byte, as these are never scrambled. The PRNG shall always be either reset or clocked (four new PRNG bits generated) after every nibble (including idles and commands), regardless of whether or not the nibble was scrambled.

NOTE: Figure 11 shows a case that will occur in normal operation whenever X_X is immediately followed by another command octet such as X_8. In this case, a second PRNG reset occurs as a result of the detection of a second pair of X symbols.

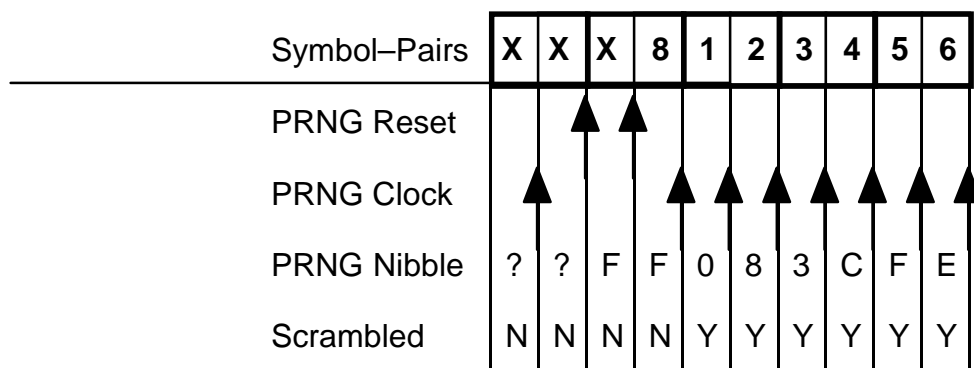

Figure 11: Start of cell symbol-pairs

Because the scrambler is designed to spread the signal across the spectrum, the reset of the scrambler/de-scrambler by the X_X symbol-pair command (the reset state is "3FF"x) should not occur too often.

For this PRNG to approximate a random source, it is recommended that the time between PRNG resets be no less than 100 μs. A maximum of 500 ms between resets is recommended to limit the time two end stations can be misaligned in the scrambler sequence.

5.1.1 PRNG sequence

For clarification purposes, the PRNG sequence for each nibble (starting from its reset state) is as follows:

F, 0, 8, 3, C, F, E, 8, C, 7, C, C, 7, D, 4, 3, 9, 4, 0, 0, 1, 8, 4, 4, 0, 3, 9, 5, 8, 4, 5, 8, 7, D, 5, B, D, 0, 0, 3, 8, D...

5.2 4B5B block coding and decoding

A 4B5B encode/decode scheme is utilized to ensure that an adequate number of transitions occur on the line. The code provides the following features:

- provides an average of over three transitions per five bit symbol;
- run length is limited to less than or equal to five;
- free of direct current (dc) frequencies on average.

Each symbol of the code is composed of five bits. Of the 32 possible symbols, 17 are valid in this implementation. The remaining 15 symbols are invalid.

The 17 valid symbols represent 16 four-bit data nibbles (hex 0 through F) and the one Escape (X) code. This Escape symbol has the "Comma" property of being unique among all possible valid symbol pairs. Table 10 below lists the valid four-bit nibble to five-bit symbol conversions.

Table 10 shall be used to encode data nibbles for transmission and to decode five-bit symbols upon reception. All symbols not listed in this table shall be invalid.

Table 10: Conversion table—four-bit command/data to five-bit symbols

Data	Symbol	Data	Symbol	Data	Symbol	Data	Symbol
0000	10101	0001	01001	0010	01010	0011	01011
0100	00111	0101	01101	0110	01110	0111	01111
1000	10010	1001	11001	1010	11010	1011	11011
1100	10111	1101	11101	1110	11110	1111	11111
ESC (X)	00010						
NOTE:	The binary values for four-bit data nibbles and five-bit encoded symbols in table 10 are shown most-significant bit first (i.e., at the left).						

For each ATM cell processed, the data within shall be scrambled, encoded and NRZI-coded before it is transmitted. Likewise on the receiver, once a start of cell command is detected, the serial data is NRZI decoded, and the resulting five-bit symbols decoded to form a data nibble. The nibbles are then descrambled and re-combined to form the ATM cell.

5.2.1 Symbol-pair level code structure

Five-bit encoded symbols shall always be paired. Two types of symbol pair entities are defined which represent:

- Commands; and
- Data octets.

Commands are composed of the Escape symbol followed by any of the 16 data symbols or by the Escape symbol. This provides 17 possible Commands of which three are defined and valid. The set of three valid (bold) and 14 invalid (reserved for future use) commands are:

- **X_X = Start-of-cell (with scrambler reset);**
- X_0 = Invalid (reserved for future use);
- X_1 = Invalid (reserved for future use);
- X_2 = Invalid (reserved for future use);
- X_3 = Invalid (reserved for future use);
- X_4 = Start-of-cell (with no scrambler reset);
- X_5 = Invalid (reserved for future use);
- X_6 = Invalid (reserved for future use);
- X_7 = Invalid (reserved for future use);
- **X_8 = Sync_Event;**
- X_9 = Invalid (reserved for future use);
- X_A = Invalid (reserved for future use);
- X_B = Invalid (reserved for future use);
- X_C = Invalid (reserved for future use);
- X_D = Invalid (reserved for future use);
- X_E = Invalid (reserved for future use);
- X_F = Invalid (reserved for future use).

All the above described Command symbol pairs (X_X, X_4, and X_8) shall be transmitted in symbol-pair alignment. The symbol-pair alignment boundary shall be defined by the first occurrence of a Command symbol-pair. Subsequent Command symbol-pairs shall be transmitted in symbol-pair alignment with the first Command symbol-pair.

All five-bit encoded symbols shall be transmitted serially with the most significant bit transmitted first.

5.2.2 Cell delineation

Cell delineation shall be accomplished by pretending either of two valid commands to the each ATM cell before transmission. As defined above, the two valid start of cell commands are:

- **X_X = Start-of-cell (with scrambler reset); and**
- **X_4 = Start-of-cell (with no scrambler reset).**

5.2.3 Support for a timing signal

Transport of a timing sync pulse to support isochronous communications may be accommodated. A special Sync_Event command symbol-pair, X₈, may be inserted into the transmitted stream at any symbol-pair boundary.

It is expected that this means will be used to carry an 8 kHz timing signal although this feature could be used to carry other timing references.

The Sync_Event timing marker command shall be generated at the next octet boundary after the incoming synchronization event is detected. The Sync_Event command symbol-pair shall have priority over all line activity (data or command symbol pairs) and shall be transmitted at the next symbol-pair boundary after the incoming synchronization event is detected. When this occurs during a cell transfer, the data transfer shall be temporarily interrupted on a symbol-pair boundary and the X₈ command symbol-pair shall be inserted. This condition is the only allowable interrupt in an otherwise contiguous transfer of the 54 symbol-pair stream (one command symbol-pair plus 53 data symbol pairs).

As an option, when a Sync_Event command is detected by the receiver (ATM user equipment), the Sync_Event command can be "wrapped around" and transmitted onto the upstream path (to the ATM network equipment).

Figure 12 is an illustration of cell structure showing Start-of-cell commands with and without Scrambler Reset, and a Sync_Event command interrupting the flow of Cell N+1.

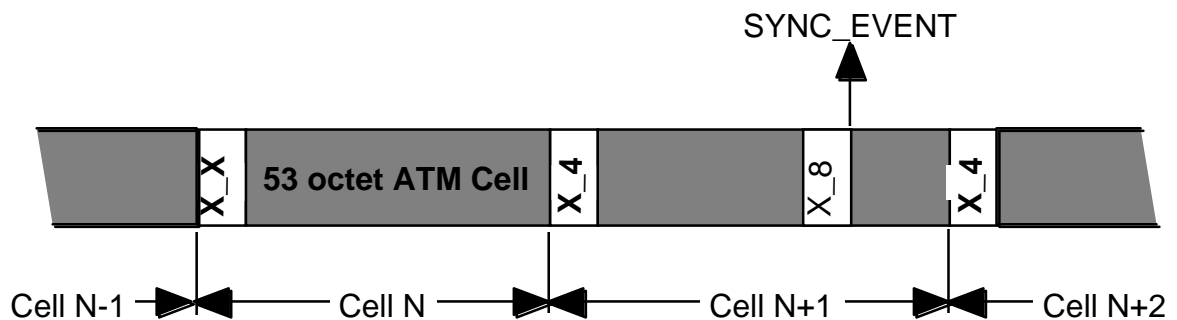

Figure 12: Example of cell delineation and Sync_Event using commands

In the example above, the Nth ATM cell is preceded by a X_X start-of-cell command. This causes both the scrambler and the descrambler to reset its pseudo-random nibble generators to its initial state. For cell N+1, the ATM cell is simply preceded by an X₄ start-of-cell command without scrambler/descrambler reset. Also in cell N+1, a timing sync pulse results in an X₈ timing marker command.

Reception of any command other than X_X, X₄ or X₈ within the 53 octet ATM cell shall be considered an error and the cell may be discarded. Reception of the X_X or X₄ command within the 53 octet ATM cell shall cause the octets of the cell that have been received to be discarded and the reception of a new cell to be initiated.

On the receiver, the decoder shall determine from the received symbols whether a timing marker command (X₈) or a start-of-cell command was sent (X_X or X₄). Anytime a start-of cell command is detected, the next 53 octets received shall be decoded and forwarded to the descrambler.

Transmissions during idle states (where no command or data are being transmitted) will continually be sent out onto the line. This arbitrary data will continue to be encoded and scrambled to maintain synchronization of the receive PLL. Upon the beginning of a valid cell transmission, the command symbol-pair would be immediately initiated. (Note that the 4B5B code guarantees a maximum run length of five bits. This, in addition to the fact that all non control octets are scrambled, will provide more than sufficient transitions to maintain bit sync during idle states.)

The TC sublayer shall transfer to and from the ATM layer complete 53-octet ATM cells.

5.3 NRZI encoding and decoding

In order to bound the run length of either logic 1s or 0s during transmission, data symbols from the encoder shall be serialized and NRZI encoded before transfer to the PMD layer.

Each symbol shall be serialized most significant bit first, and then NRZI encoded.

Serial data received from the PMD shall be NRZI decoded before symbol boundaries are detected.

5.4 HEC generation and verification

The Header Error Control (HEC) covers the entire cell header. For the private environment, only detection of bit errors is described. Support of bit error detection based on HEC field is mandatory.

The transmitter calculates the HEC value for the first four octets of the cell header, and inserts the result into the HEC field (the last octet of the ATM cell header). The HEC field shall be an eight-bit sequence. It shall be the remainder of the division (Modulo 2) by the generator polynomial x^8+x^2+x+1 of the polynomial x^8 multiplied by the content of the header excluding the HEC field. The pattern 01010101 is XORed with the 8-bit remainder before being inserted into the HEC field.

Equipment supporting this private UNI shall implement HEC error detection as defined in ITU-T Recommendation I.432 [4].

Equipment supporting this private UNI shall generate the HEC octet as defined in ITU-T Recommendation I.432 [4].

The generator polynomial and coset used shall be in accordance with ITU-T Recommendation I.432 [4].

Figure 13 depicts the HEC verification flow at the receiver. The TC shall not forward any cell to the ATM layer which has an incorrect HEC.

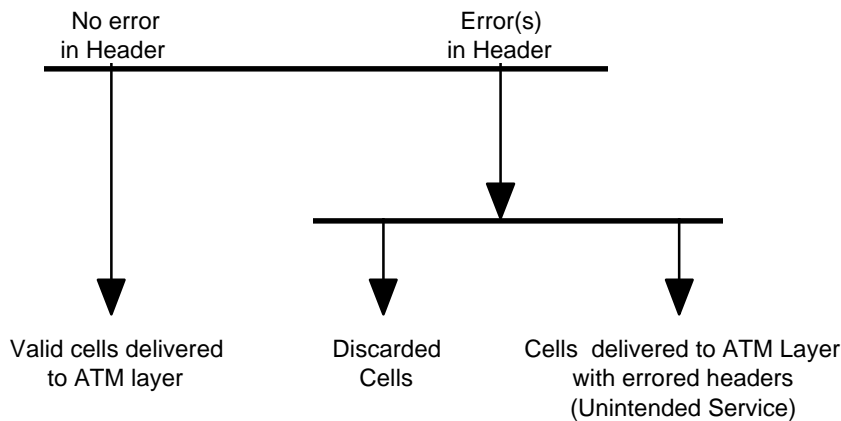

Figure13: HEC verification flow

As defined in ITU-T Recommendation I.432 [4], the HEC method is capable of single bit error correction and multiple bit error detection. Because the 4B5B block code used in this private UNI causes multiple bit errors per corrupted bit, the HEC error correction mode shall not be used.

HEC error detection is mandatory.

Upon detection of a header error, that cell shall be discarded.

Annex A (informative): Bibliography

- ITU-T Recommendation I.321 (1991): "B-ISDN protocol reference model and its applications".

History

Document history	
November 1996	Public Enquiry PE 117: 1996-11-04 to 1997-02-28