



**E**UROPEAN  
**T**ELECOMMUNICATION  
**S**TANDARD

**DRAFT**  
pr **ETS 300 805-2**

July 1996

---

Source: ETSI TC-ECMA

Reference: DE/ECMA-00109-2

ICS: 35.020

**Key words:** ATS, circuit mode, layer 3, PINX, PISN, QSIG, testing

**Private Integrated Services Network (PISN);  
Inter-exchange signalling protocol;  
Circuit mode basic services;  
Network Layer (NL);  
Part 2: Abstract Test Suite Specification (ATS)**

**ETSI**

European Telecommunications Standards Institute

**ETSI Secretariat**

**Postal address:** F-06921 Sophia Antipolis CEDEX - FRANCE

**Office address:** 650 Route des Lucioles - Sophia Antipolis - Valbonne - FRANCE

**X.400:** c=fr, a=atlas, p=etsi, s=secretariat - **Internet:** secretariat@etsi.fr

Tel.: +33 92 94 42 00 - Fax: +33 93 65 47 16

---

**Copyright Notification:** No part may be reproduced except as authorized by written permission. The copyright and the foregoing restriction extend to reproduction in all media.

© European Telecommunications Standards Institute 1996. All rights reserved.



## Contents

Foreword .....	7
1 Scope .....	9
2 Normative references .....	9
3 Definitions and abbreviations .....	10
3.1 Definitions .....	10
3.2 Abbreviations .....	11
4 Abstract Test Method (ATM) .....	11
4.1 Choice of the ATM .....	11
4.1.1 Functional subsets .....	11
4.1.2 Single- and Multi-party testing .....	12
4.2 Single PCO testing .....	12
4.2.1 Call Control testing for non-Transit PINX and Protocol Control testing .....	12
4.2.2 Segmentation and Protocol Discriminator Filter testing .....	13
4.3 Multiple PCO testing .....	14
4.3.1 Call Control testing for a Transit PINX .....	14
4.4 Test Configurations and use of Concurrent TTCN .....	14
5 Untestable Test Purposes .....	15
6 Conformance clause .....	15
7 ATS Conventions .....	16
7.1 Short names and abbreviations .....	16
7.2 Test suite type, ASP type, PDU type and Alias identifiers .....	17
7.2.1 ASP type identifiers .....	17
7.2.2 PDU type identifiers .....	17
7.2.3 Test Suite Type identifiers (Information Elements) .....	17
7.2.4 Aliases .....	18
7.3 Identifiers concerning test configuration .....	18
7.3.1 Test components .....	18
7.3.2 Test component configurations .....	18
7.3.3 Points of Control and Observations (PCOs) .....	18
7.3.4 Coordination Points (CPs) .....	18
7.3.5 CM types .....	18
7.4 Test Suite Parameter and Selection Expression identifiers .....	19
7.4.1 Test suite parameters .....	19
7.4.2 PICS Parameters .....	19
7.4.3 PIXIT parameters .....	19
7.4.4 Test Case Selection Expressions .....	19
7.4.5 Abbreviations used in PIXIT parameters and Test Case Selection Expressions .....	19
7.5 Miscellaneous identifiers .....	21
7.5.1 Test suite operations .....	21
7.5.2 Test suite constants .....	21
7.5.3 Test suite variables .....	21
7.5.4 Test case variables .....	22
7.5.5 Timers .....	22
7.6 Constraints .....	22
7.6.1 TTCN Test suite type constraints .....	22
7.6.2 ASP constraints .....	22
7.6.3 PDU constraints .....	22
7.6.4 CM constraints .....	23
7.7 Dynamic part .....	23

7.7.1	Test Case identifiers .....	23
7.7.2	Test Step identifier .....	23
7.7.3	Default identifier .....	24
7.8	Notation .....	24
8	Test case and test purpose mapping .....	25
Annex A (normative):	Partial PIXIT proforma .....	26
A.1	Identification summary .....	26
A.2	ATS summary .....	26
A.3	Test laboratory .....	26
A.4	Client identification .....	26
A.5	SUT .....	26
A.6	Protocol layer information .....	27
A.6.1	Protocol identification .....	27
A.6.2	IUT information .....	27
A.6.2.1	General information .....	27
A.6.2.1.1	General Configuration .....	27
A.6.2.1.2	Addressing .....	28
A.6.2.2	Clearing Procedures .....	29
A.6.2.3	General Sending of Messages .....	30
A.6.2.4	Originating PINX .....	31
A.6.2.5	Terminating PINX .....	32
A.6.2.6	Incoming Gateway PINX .....	33
A.6.2.7	Outgoing Gateway PINX .....	33
A.6.2.8	Transit PINX .....	34
A.6.2.9	Status Procedure .....	35
A.6.2.10	Layer Management .....	35
A.6.2.11	Error Handling .....	36
A.6.2.12	Segmentation .....	36
A.6.2.13	Timers .....	36
A.6.3	Called Party Numbers in the PIXIT .....	36
Annex B (normative):	Protocol Conformance Test Report (PCTR) Proforma for PSS1_BC Layer .....	38
B.1	Identification summary .....	38
B.1.1	Protocol conformance test report .....	38
B.1.2	IUT identification .....	38
B.1.3	Testing environment .....	38
B.1.4	Limits and reservation .....	39
B.1.5	Comments .....	39
B.2	IUT Conformance status .....	39
B.3	Static conformance summary .....	39
B.4	Dynamic conformance summary .....	39
B.5	Static conformance review report .....	40
B.6	Test campaign report .....	41
B.7	Observations .....	48
Annex C (Normative):	Abstract Test Suite (ATS) for PSS1_BC .....	49

C.1	The TTCN Graphical form (TTCN.GR) .....	49
C.2	The TTCN Machine Processable form (TTCN.MP) .....	49
	History.....	50

Blank page

## Foreword

This draft European Telecommunication Standard (ETS) has been produced by the standardizing Information and Communication Systems (ECMA) on behalf of its members and those of the European Telecommunications Standards Institute (ETSI), and is now submitted for the Public Enquiry phase of the ETSI standards approval procedure.

This ETS comprises two parts with the generic title " Private Integrated Services Network (PISN); Inter-exchange signalling protocol; Network Layer (NL); Circuit mode basic services". The title of each part is listed below:

Part 1: "Test Suite Structure and Test Purposes"

**Part 2: "Abstract Test Suite Specification"**

<b>Proposed transposition dates</b>	
Date of latest announcement of this ETS (doa):	3 months after ETSI publication
Date of latest publication of new National Standard or endorsement of this ETS (dop/e):	6 months after doa
Date of withdrawal of any conflicting National Standard (dow):	6 months after doa

Blank page



## 1 Scope

This European Telecommunication Standard (ETS) contains the Abstract Test Suite (ATS) specification for the Network Layer, Circuit Mode Basic Services of the Inter-exchange signalling protocol, for Private Integrated Services Networks (PISN).

The objective of this ATS specification is to provide conformance tests which give a high probability of inter-operability of the Network Layer. The ATS specification covers the procedures described in ETS 300 172 [1].

The ISO standard for the methodology of conformance testing (ISO/IEC 9646-1 [2], ISO/IEC 9646-2 [3] and ISO/IEC 9646-3 [4]) is used as basis for the test methodology.

This ATS specification is applicable to implementations which support either a Basic Rate or a Primary Rate access interface, or both, operating over a leased line. It is applicable to various PINX roles, i.e. Originating, Terminating, Transit, Incoming/Outgoing Gateway .

Annex A provides the Partial Protocol Implementation eXtra Information for Testing (PIXIT) Proforma of this specification.

Annex B provides the Protocol Conformance Test Report (PCTR) Proforma of this specification.

Annex C provides the Tree and Tabular Combined Notation (TTCN) part of this specification.

## 2 Normative references

This ETS incorporates by dated and undated reference, provisions from other publications. These normative references are cited in the appropriate places in the text and the publications are listed hereafter. For dated references, subsequent amendments or revisions to of any of these publications apply to this ETS only when incorporated in it by amendment or revision. For undated references the latest edition of the publication referred to applies.

- [1] ETS 300 172 (1995): "Private Integrated Services Network (PISN); Inter-Exchange Signalling protocol, Circuit Mode Basic Services services".
- [2] Draft prETS 300 805-1 (1996): "Private Integrated Services Networks (PISN); Inter-exchange signalling protocol; Circuit mode basic services; Network layer (NL); Test Suite Structure and Test Purposes (TSS&TP)".
- [3] ISO/IEC 9646-1 (1994): "Information Technology - Open Systems Interconnection - Conformance Testing Methodology and Framework - Part 1: General Concepts".
- [4] ISO/IEC 9646-2 (1994): "Information Technology - Open Systems Interconnection - Conformance Testing Methodology and Framework - Part 2: Abstract Test Suite Specification".
- [5] ISO/IEC 9646-3 (1992): "Information Technology - Open Systems Interconnection - Conformance Testing Methodology and Framework -Part 3: The Tree and Tabular Combined Notation (TTCN)".
- [6] ISO/IEC 9646-3 AM1 (To be published): "Information Technology - Open Systems Interconnection - Conformance Testing Methodology and Framework - Part 3: The Tree and Tabular Combined Notation. Amendment 1: TTCN Extensions (concurrent TTCN)".
- [7] ISO/IEC 9646-4 (1994): "Information Technology - Open Systems Interconnection - Conformance Testing Methodology and Framework, Part 4: Test Realisation".

- [8] ISO/IEC 9646-5 (1994): "Information Technology - Open Systems Interconnection - Conformance Testing Methodology and Framework - Part 5: Requirements on test laboratories and clients for the conformance assessment process".

### 3 Definitions and abbreviations

#### 3.1 Definitions

For the purposes of this ETS, the following definitions apply:

**Abstract Test Suite (ATS):** See ISO/IEC 9646-1 [3].

**final test purpose:** See prETS 300 805-1 [2].

**Implementation Under Test (IUT):** See ISO/IEC 9646-1 [3].

**incoming call:** See ETS 300 172 [1].

**incoming gateway PINX:** See ETS 300 172 [1].

**Lower Tester (LT):** See ISO/IEC 9646-1 [3].

**network layer:** For the purposes of this ATS the procedures described in ETS 300 172 [1].

**originating PINX:** See ETS 300 172 [1].

**outgoing call:** See ETS 300 172 [1].

**outgoing gateway PINX:** See ETS 300 172 [1].

**PICS proforma:** See ISO/IEC 9646-1 [3].

**PIXIT proforma:** See ISO/IEC 9646-1 [3].

**Point Of Control And Observation (PCO):** See ISO/IEC 9646-1 [3].

**preceding PINX:** See ETS 300 172 [1].

**Protocol Implementation Conformance Statement (PICS):** See ISO/IEC 9646-1 [3].

**Protocol Implementation Extra Information For Testing (PIXIT):** See ISO/IEC 9646-1 [3].

**segmentation:** See prETS 300 805-1 [2].

**Signalling Carriage Mechanism (SCM):** See ETS 300 172 [1].

**subsequent PINX:** See ETS 300 172 [1].

**super test purpose:** See prETS 300 805-1 [2].

**System Under Test (SUT):** See ISO/IEC 9646-1 [3].

**terminating PINX:** See ETS 300 172 [1].

**transit PINX:** See ETS 300 172 [1].

**Upper Tester (UT):** See ISO/IEC 9646-1 [2].

### 3.2 Abbreviations

For the purposes of this ETS, the following abbreviations apply:

ASP	Abstract Service Primitive
ATM	Abstract Test Method
ATS	Abstract Test Suite
CM	Communication Message
CP	Coordination Point
ETS	European Telecommunication Standard
ISO	International Organisation for Standardisation
IUT	Implementation Under Test
LT	Lower Tester
MTC	Master Test Component
PC	Protocol Control
PCO	Point of Control and Observation
PDU	Protocol Data Unit
PICS	Protocol Implementation Conformance Statement
PINX	Private Integrated Services eXchange
PISN	Private Integrated Services Network
PIXIT	Protocol Implementation eXtra Information for Testing
PSS1	Private Integrated Signalling System Number 1
PTC	Parallel Test Component
SUT	System Under Test
TP	Test Purpose
TTCN	Tree and Tabular Combined Notation
UT	Upper Tester

## 4 Abstract Test Method (ATM)

This clause describes the different Abstract Test Methods (ATM) used for testing the Network Layer protocol. Two methods are applied; the Remote single layer test method, and the Multi-Party test method.

### 4.1 Choice of the ATM

#### 4.1.1 Functional subsets

The choice of functional subsets is based primarily on the fact that PSS1 is subdivided into two functional entities: Call Control and Protocol Control. Each of these two functional entities is tested using different sets of Test Purposes and hence different Test Cases.

The Protocol Control entity is further divided into three sublayers: the Protocol Discriminator Filter sublayer, the Message Segmentation sublayer and the Other Protocol Control Functions sublayer.

From the viewpoint of this ATS, PSS1 is considered to be divided into two functional subsets, as shown in Figure 1. The first of these functional groups consists of the Protocol Discriminator Filter sublayer and the Message Segmentation sublayer. The second functional group consists of the Other Protocol Control Functions sublayer and the Call Control entity. A different PCO is used for each of these functional groups when being tested.

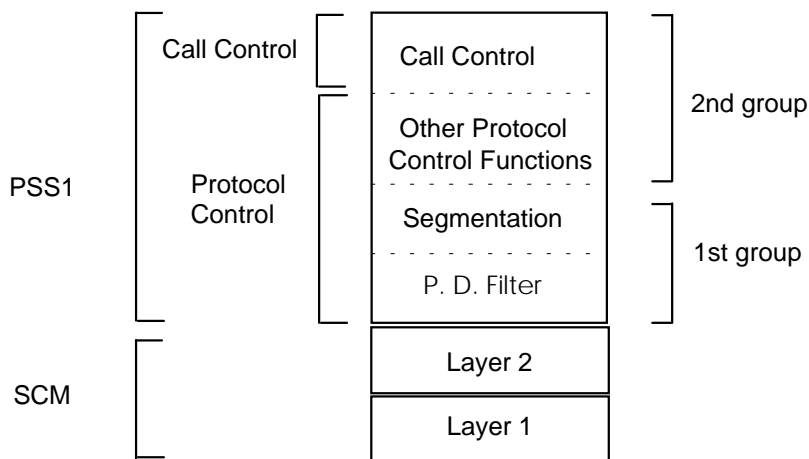

NOTE: In the remainder of section 4, the term "Protocol Control" refers only to the "Other Protocol Control Functions" sublayer

**Figure 1: PSS1 functional subsets**

#### 4.1.2 Single- and Multi-party testing

For Call Control, the protocol defines different roles that a PINX can play: it can be an end or gateway PINX (Originating, Terminating, Incoming Gateway, Outgoing Gateway), or a Transit PINX. In the first case, only one interface needs to be tested, and in the second case, two interfaces need to be tested simultaneously.

#### 4.2 Single PCO testing

Single PCO testing applies to the Segmentation and Protocol Discriminator Filter, to the Protocol Control, and to the Call Control for an Originating, Terminating, Incoming Gateway or Outgoing Gateway PINX.

##### 4.2.1 Call Control testing for non-Transit PINX and Protocol Control testing

As shown in Figure 2, the IUT is the Protocol Control and Call Control part, and it is an end-system. It is not possible to observe and control the upper service boundary of the IUT. Consequently, the test method chosen is the Remote Test Method, where the co-ordination procedures are expressed in an informal way. The test system will only contain one LT and no UT. The PCO, called LX, is located between the Protocol Control and Call Control part, and the Segmentation part. Only unsegmented Protocol Data Units (PDUs) are exchanged.

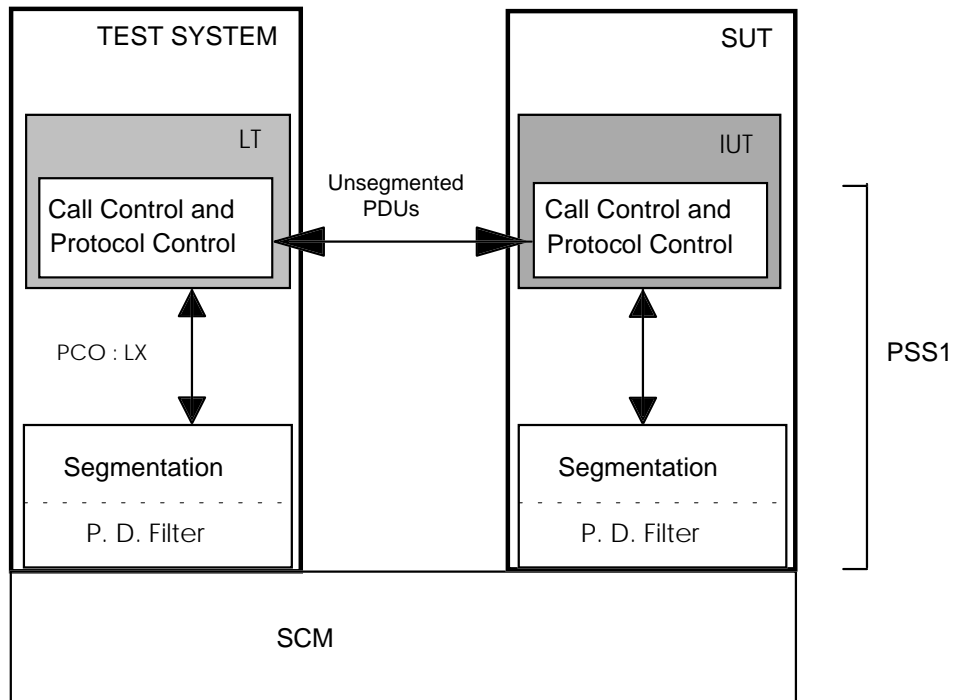

**Figure 2: Remote single layer test method for Protocol Control and Call Control for non-Transit PINX**

**4.2.2 Segmentation and Protocol Discriminator Filter testing**

As shown in Figure 3, the IUT is the Segmentation and Protocol Discriminator Filter part, and it is an end-system. It is not possible to observe and control the upper service boundary of the IUT. Consequently, the test method chosen is the Remote Test Method, where the co-ordination procedures are expressed in an informal way. The test system will only contain one LT and no UT. The PCO, called LSEG, is located between the Segmentation and Protocol Discriminator Filter part, and the SCM. The PDUs exchanged are SEGMENT PDUs and unsegmented PDUs.

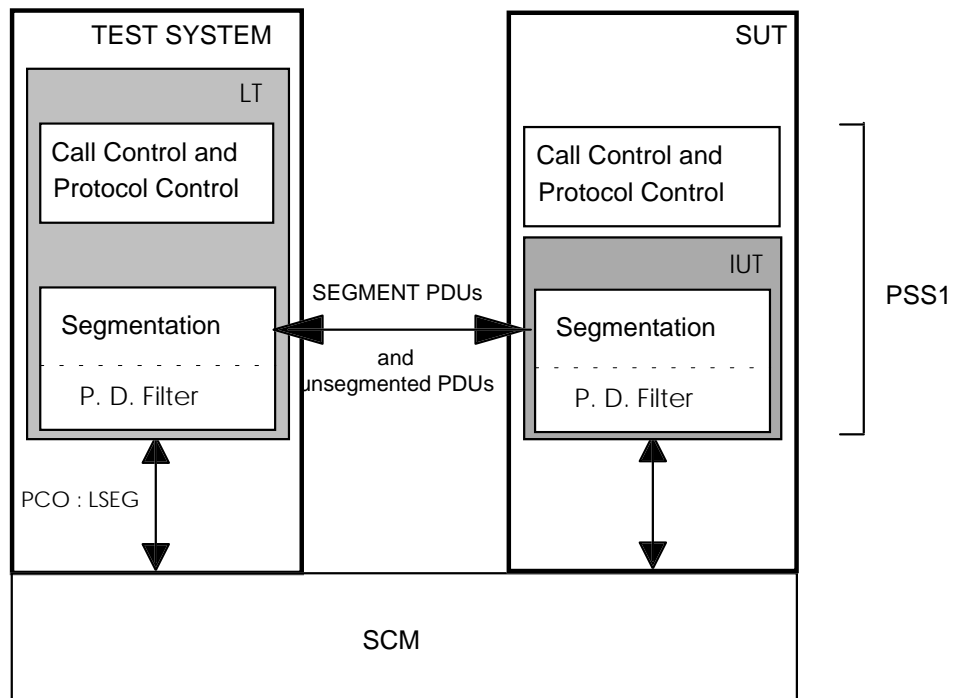

**Figure 3: Remote single layer test method for Segmentation and Protocol Discriminator Filter**

4.3 Multiple PCO testing

Multiple PCO testing applies to the Protocol Control and the Call Control for Transit PINX.

4.3.1 Call Control testing for a Transit PINX

As shown in Figure 4, the IUT is the Protocol Control and Call Control part of the Transit PINX, and it is an open-relay system. Consequently, the test method chosen is a Multi-Party Test Method with no UT. The test system will contain two LTs attached to the IUT via two PCOs, called LX and LY, located The PCO, called LSEG, just between the Protocol Control and Call Control part, and the Segmentation part. The PDUs exchanged are only unsegmented PDUs.

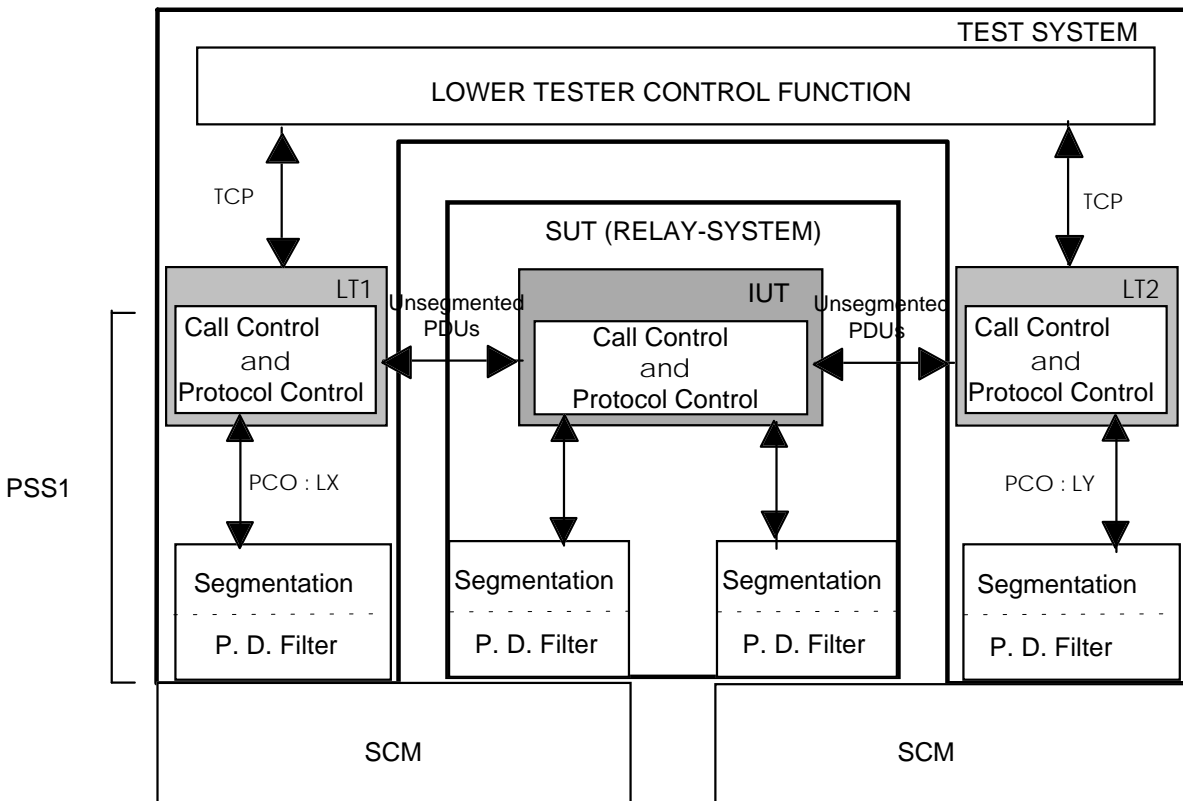

Figure 4: Multi-party test method for Protocol Control and Call Control for Transit PINX

4.4 Test Configurations and use of Concurrent TTCN

As this ATS covers both single-party testing using non-concurrent TTCN, and multi-party testing using concurrent TTCN, the notation chosen for the complete ATS is the concurrent TTCN syntax. Therefore, test components are defined to describe the two configurations: the "mono" configuration and the "transit" configuration, as shown in Figure 5 and 6.

The mono configuration is used in case of single-party testing, i.e. for the Protocol Control testing, the Call Control testing for non-transit PINX, and the Segmentation and Protocol Discriminator Filter testing. Only one test component, which is the master test component MTC\_MONO, connected to the IUT via the PCOs LX or LSEG, is needed in this case.

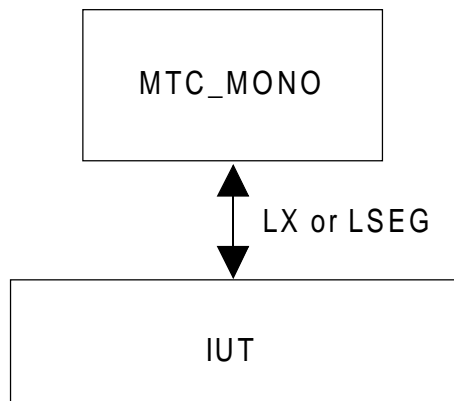

Figure 5: Mono configuration

The transit configuration is used in case of multi-party testing, i.e. for the Protocol Control and Call Control testing for transit PINX. In this case, three test components are needed, these are the Master Test Component MTC\_TRANSIT, and the two Parallel Test Components PTC\_X and PTC\_Y, which are connected to the Master Test Component via the two Coordination Points CPX and CPY. PTC\_X and PTC\_Y are further connected to the IUT via the two PCOs LX and LY.

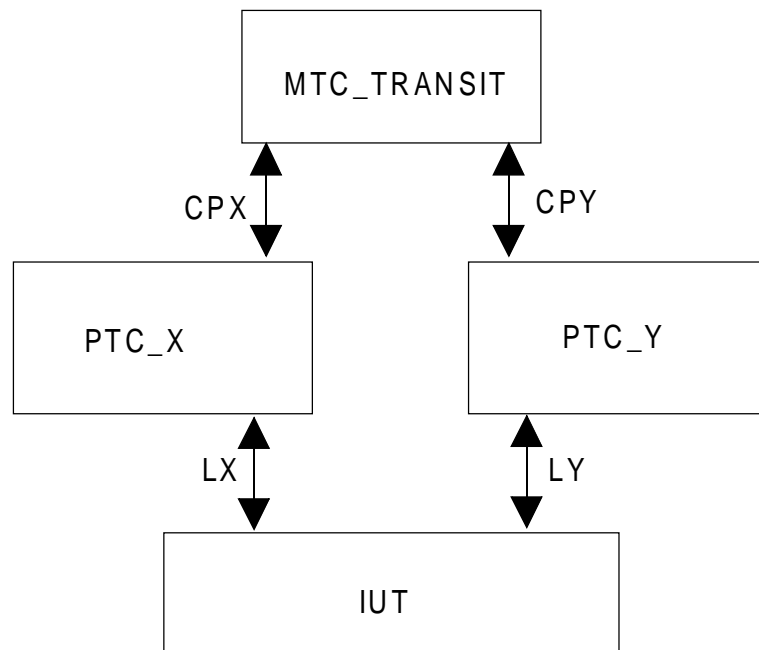

Figure 6: Transit configuration

## 5 Untestable Test Purposes

Due to the ATMs chosen in this ATS or other restrictions, the following super test purposes have been identified as being untestable, and therefore have not been derived into final test purposes:

SP005, SP006, SP014, SP099, SP159, SP161, SP162, SP163, SP164.

## 6 Conformance clause

This specification is applicable to implementations which support either a Basic Rate or a Primary Rate access interface, or both, operating over a leased line. A means of test may offer one or both access types.

The test realiser shall comply with the requirements of ISO/IEC 9646-4 [7]; in particular, these concern the realisation of an Executable Test Suite based on each Abstract Test Suite.

Test laboratories running conformance test services using this ATS shall comply with ISO/IEC 9646-5 [8].

A Means of Test conforming to this ATS shall implement at least a subset of test cases which is the complete subset of test cases selected according to the selection expressions for a particular consistent set of test suite parameters. Such a subset may include only test cases applicable to Transit PINX or End PINX testing.

Certain Test Cases are selected only when the IUT is configured as A or as B. Therefore, in order to cover all Test Cases applicable to an implementation, it is necessary to change the configuration and run the omitted Test Cases with the appropriate changes to the Test Suite Parameter IUT\_A.

## 7 ATS Conventions

This clause describes the conventions adopted in this ATS and gives the naming conventions used for the different ATS elements.

### 7.1 Short names and abbreviations

Throughout the ATS short names and abbreviations for PDUs and ASPs are used, also abbreviations for Information Elements are used. These are defined in tables 1 to 3.

**Table 1: Short names and abbreviations for PDUs**

PDU name	Short Name	Abbreviation
ALERTING	ALERTING	ALE
CALL PROCEEDING	CALL_PROC	CPR
CONNECT	CONNECT	CON
CONNECT ACKNOWLEDGE	CONN_ACK	COA
DISCONNECT	DISCON	DIS
FACILITY	FACILITY	FAC
INFORMATION	INFO	INF
NOTIFY	NOTIFY	NOT
PROGRESS	PROGRESS	PRO
RELEASE	RELEASE	REL
RELEASE COMPLETE	REL_COM	RLC
RESTART	RESTART	RES
RESTART ACKNOWLEDGE	REST_ACK	RSA
SETUP	SETUP	SET
SETUP ACKNOWLEDGE	SETUP_ACK	SUA
STATUS	STATUS	STA
STATUS ENQUIRY	STAT_ENQ	STQ
Error PDU (NOTE 1)	ERROR	ERR
Q931 message (NOTE 2)	Q931MSG	Q931
Generic message (NOTE 3)	GENERIC	GEN
NOTE 1	ERROR_PDU is used for incorrectly coded messages sent by the tester which do not have the correct structure for any valid message type.	
NOTE 2:	Q931MSG is used to receive any message without examining its contents.	
NOTE 3:	GENERIC is used for messages received by the tester where the message type may vary but it is necessary to examine the contents of the message.	



**Table 2: Short names and abbreviations for ASPs**

ASP name	Short name	Abbreviation
DL-DATA-REQUEST	DL_DAT_REQ	DLRQ
DL-DATA-INDICATION	DL_DAT_IND	DLIN
DL-ESTABLISH-REQUEST	DL_EST_REQ	DERQ
DL-ESTABLISH-INDICATION	DL_EST_IND	DEIN
DL-ESTABLISH-CONFIRM	DL_EST_CON	DECO
DL-RELEASE-REQUEST	DL_REL_REQ	DRRQ
DL-RELEASE-INDICATION	DL_REL_IND	DRIN
DL-RELEASE-CONFIRM	DL_REL_CON	DRCO

**Table 3: Abbreviations for Information Elements**

Information Element name	Abbreviation
Protocol discriminator	PD
Call Reference	CR
Message type	MT
Sending complete	SC
Locking shift (NOTE 1)	LS
Bearer capability	BCAP
Cause	CAU
Called party number	CDPN
Called party subaddress	CDPS
Calling party number	CGPN
Calling party subaddress	CGPS
Channel identification	CHI
Connected number	CNDN
Connected subaddress	CNDS
Call state	CST
Facility	FIE
High layer compatibility	HLC
Low layer compatibility	LLC
Notification indicator	NOT
Party category	PC
Progress indicator	PI
Restart indicator	RI
Transit counter	TC
Unspecified IE (NOTE 2)	UNSP
NOTE 1: LS4 and LS5 are used as the abbreviations for locking shift to codesets 4 and 5.	
NOTE 2: UNSP is used where an IE sent to the IUT does not have the structure of any valid IE.	

## 7.2 Test suite type, ASP type, PDU type and Alias identifiers.

### 7.2.1 ASP type identifiers

The identifier of an ASP is the short name of the ASP.

EXAMPLE: **DL\_DAT\_REQ** is the DL-DATA-REQUEST ASP.

### 7.2.2 PDU type identifiers

The identifier of a PDU type is the short name of the PDU.

EXAMPLE: **DISCON** is the DISCONNECT PDU.

### 7.2.3 Test Suite Type identifiers (Information Elements)

The identifier of a test suite type describing a single information element is the abbreviation for the IE with the suffix "\_TYP".

EXAMPLE 1: **BCAP\_TYP** is the Bearer capability IE type.

The identifier for a type describing an invalid variant of an IE is the abbreviation for the IE with the suffix "\_TYP\_BAD".

EXAMPLE 2:           **CR\_TYP\_BAD** is a type for an invalid Call Reference IE.

The element (Field) names used within structured types which describing Information Elements (IEs) consist of the abbreviation for the IE followed by an underscore, followed by, in abbreviated form, and in lower case, the name of the relevant field.

EXAMPLE 3:           **BCAP\_codstd** is the Coding Standard Field type of the Bearer Capability IE.

#### 7.2.4       **Aliases**

Aliases are used in the ATS to show which PDU is being sent or received within an ASP. The identifiers for aliases consist of the short name of the PDU, with the suffix "rq" used in aliases for DL\_DAT\_REQ (PDUs sent by the tester) and the suffix "in" used in the case of aliases for DL\_DAT\_IND (PDUs received by the tester).

EXAMPLE:           **CONN\_ACKrq** is an alias for DL\_DAT\_REQ used for sending a CONNECT ACKNOWLEDGE message.

### 7.3       **Identifiers concerning test configuration**

#### 7.3.1       **Test components**

The name of an Master Test Component (MTC) is composed of the prefix "MTC\_", followed by a string in upper case identifying the function of the MTC.

EXAMPLE 1:           **MTC\_MONO** is the Master Test Component used in the mono configuration.

The name of a Parallel Test Component (PTC) is composed of the prefix "PTC\_", followed by an upper case letter indicating which interface the PTC controls.

EXAMPLE 2:           **PTC\_X** is the Parallel Test Component representing the X interface of the IUT.

#### 7.3.2       **Test component configurations**

The name of a configuration is composed of the prefix "Config\_", followed by a name indicating the function of the configuration. The first letter of this name is in upper case and the remainder in lower case.

EXAMPLE:           **Config\_Transit** is used for transit configuration.

The two figures in subclause 4.4 show a logical view of the configurations used.

#### 7.3.3       **Points of Control and Observations (PCOs)**

The Point of Control and Observation identifiers are composed of "L" (for Lower tester) followed by an upper case letter indicating the interface that the PCO is connected to.

EXAMPLE:           **LX** is the PCO on interface X in the LT.

#### 7.3.4       **Coordination Points (CPs)**

The Coordination Point identifiers are composed "CP" followed by an upper case letter indicating the PTC the CP communicates with. (All CPs used are between the MTC and one PTC)

EXAMPLE:           **CPX** is a Coordination Point between the MTC\_TRANSIT component and the PTCX component.

#### 7.3.5       **CM types**

The identifier of a Coordination Message type is a string in upper case.

EXAMPLE:                **READY** is a CM used to request if, or to indicate that, a PTC is ready

## 7.4        **Test Suite Parameter and Selection Expression identifiers**

### 7.4.1        **Test suite parameters**

Two categories of test suite parameters can be distinguished as follows;

- **PICS category:**                        those derived from the PICS proforma questions
- **PIXIT category:**                      those derived from the PIXIT proforma questions

and the latter can be further subdivided into the following parts;

- PIXIT values:                            parameters concerning the protocol itself.
- Configuration parameters:            parameters concerning the IUT configuration
  - Values:                                Values used within test cases
  - Boolean:                                Parameters indicating if the corresponding value is available.

All the PICS parameters and PIXIT parameters of the PIXIT values are boolean. The types of the Configuration Values depend on the type of information represented by the parameter.

The identifier of the test suite parameter depends on whether it is a PICS or PIXIT parameter. In each case it starts with a prefix identifying the category.

### 7.4.2        **PICS Parameters**

The identifiers of PICS parameters start with the prefix "PC\_" followed by the reference of the item in the relevant PICS.

EXAMPLE 1:                PC\_B3 relates to item B3 in the Basic Call PICS "Is the implementation capable of functioning as a Transit PINX?",

### 7.4.3        **PIXIT parameters**

The identifiers of PIXIT parameters in the PIXIT values and Configuration values categories start with the prefix "PX\_" or "tsp\_" respectively. This is followed by a string of abbreviations, separated by underscores, describing the meaning of the parameter as described in subclause 7.4.5.

EXAMPLE 1:                PX\_S0\_ISset is a parameter meaning "Does the IUT support implicit sending of SETUP in state 0".

EXAMPLE 2:                tsp\_InvNum is a parameter meaning "A number which the IUT can determine to be invalid".

The identifiers of PIXIT parameters in the boolean configuration category are as the corresponding value with the prefix "CO\_" replacing "tsp\_".

EXAMPLE 3:                CO\_InvNum is a parameter meaning "Is a number which the IUT can determine to be invalid available"

### 7.4.4        **Test Case Selection Expressions**

The identifiers of Test Case Selection Expressions consist of a string of abbreviations, separated by underscores, describing the meaning of the parameter as described in subclause 7.4.5.

EXAMPLE:                TR\_ENT\_TCC5\_XS2 is a selection expression meaning when true "The IUT, as a transit PINX, can enter state TCC5 with interface X in state 2".

### 7.4.5        **Abbreviations used in PIXIT parameters and Test Case Selection Expressions**

The abbreviations used in the PIXIT parameters and Test Case Selection Expressions are defined in table 4. While it is possible to see from these abbreviations the approximate meaning of the parameter or

expression it is necessary to refer to the appropriate table in the TTCN ATS or the referenced PIXIT question to determine the exact meaning.

Table 4

Abbreviation	Meaning
OC, Out_Call	Outgoing call
IC, In_Call	Incoming call
TR	Transit PINX
TE	Terminating PINX
OI	Originating PINX
OG	Outgoing Gateway PINX
IG	Incoming Gateway PINX
ENT	Enters state
UN	Unstable
S8 etc.	State 8. etc. (If this is the last component it means that the IUT can enter and is stable in the specified state. If it is followed by a message it means that the IUT can send the message in the specified state).
T304etc.	Timer T304etc. implemented
no	Number
rel	Relays
REL etc.	IUT can send RELEASE message etc. (Message abbreviations are as defined in table ?).
iREL etc.	Implicit send of RELEASE possible etc.
iCLEAR	Implicit clearing possible
imp	Feature is implemented
retr	Retransmits
onUNREC	IUT sends message on receiving unrecognised message
onDLestCON	IUT sends message on DL_ESTABLISH_CONFORM
TC	IUT supports transit counter functions
TCinclude	IUT includes transit counter IE
TClimit	Limit for Transit Counter value
Ta	Tones and Announcements associated with Call Clearing
PI etc.	Including Progress Indicator IE etc. (IE abbreviations are as defined in table 3)
pref, excl	Preferred, Exclusive (Values of Preferred/Exclusive bit)
unres, speech, audio, udi_ta	Unrestricted Digital Info, Speech, 3.1kHz Audio, UDI with Tones & announcements (Bearer Capabilities)
Bcap	Bearer Capability IE
NoCLIR	Without the Calling/Connected Line Identification Restriction supplementary service being invoked.
Echnum, Echnum2	Valid channel numbers
Nechnum	Invalid channel number
NoChans	Number of channels available

Abbreviation	Meaning
Cnum	“Complete Number”: a number which the IUT can determine to be complete (Note 1)
Fnum	“Full Number”: a number which is complete in the numbering plan implemented in the IUT and which the IUT may, or may not, determine to be complete.
Inum	“Incomplete number” a number which the IUT can determine is complete.
Onum	“Overlap number”: a number which the IUT cannot determine to be complete (i.e. causes it to use overlap receiving).
Rnum	“Routing Number”: a number which is sufficient for the IUT (a transit PINX) to be able to determine is to be routed on a particular inter-PINX link, but is insufficient for the IUT to determine to be complete
NRnum	“Non-Routing Number” is a number is insufficient for the IUT (a transit PINX) to determine is to be routed on a particular inter-PINX link, but may, with the addition of further digits, so be routed.
InvNnum	“Invalid Number” : an number which the IUT can determine is unassigned in the numbering plan that it is configured for.
Tnum	“Timer Number”: a number which is complete in the numbering plan that the IUT is configured for, but which the IUT cannot determined to be complete (in the absence of Sending complete) until expiry of T302
sXYnum	Supplementary X-Y number (X and Y can be C, R or NR representing Complete, Routing or non-Routing). This is a number which when concatenated to the number given as an “X number” produces a “Y number”.
Cnum1 etc.	First part of Cnum etc.
Pre	Preceding PINX
Tester_NumDigits	Number of terminal attached to tester as seen by IUT
Parts	Number can be divided in parts
time	time (duration)
len	Length

## 7.5 Miscellaneous identifiers

### 7.5.1 Test suite operations

The Test Suite Operation identifiers are composed of string in lower case separated by underscore characters ('\_').

EXAMPLE:                   **choose\_bcnp** is used for returning the appropriate Information Transfer Capability field of the Bearer Capability IE.

### 7.5.2 Test suite constants

The Test Suite Constant identifiers begin with the prefix 'C\_', followed by a string identifying the function of the constant. Where the constant represents the value of the message type for a specific message the string consists of "MT" (the abbreviation for the Message Type IE) followed by the abbreviation for the specific message. In other cases the string starts with the abbreviation for the appropriate IE and there is no restriction in the characters in the remainder of the string.

EXAMPLE:                   **C\_MTCOA** is the **Message Type** IE value of a **CONNECT ACK** message.

### 7.5.3 Test suite variables

No Test Suite Variables have been used in the ATS.

#### 7.5.4 Test case variables

The Test Case Variable identifiers begin with the prefix "CV\_", followed by a string with no restriction on the type of characters.

EXAMPLE: **CV\_CRVALUE** is a Call Reference Value used by one call between the IUT and the tester.

#### 7.5.5 Timers

The identifier for a test suite timer derived from a protocol timer defined in ETS 300 172 [1] is the name of the timer from the base standard with the suffix "\_max" or "\_min" to indicate the minimum or maximum duration of the timer.

EXAMPLE 1: **T313\_max** is a test suite timer corresponding to the maximum duration of the protocol timer T313.

The identifiers for other timers (e.g. those used while waiting for a response from the IUT) consist of "T\_" followed by a name in upper case.

EXAMPLE 2: **T\_REST** is a timer for the response of the IUT to a RESTART message.

### 7.6 Constraints

#### 7.6.1 TTCN Test suite type constraints

Test suite type constraint identifiers consist of the abbreviation for the IE followed by two digits for a valid constraint or one upper case letter (X or Y) and one digit for an erroneous constraint.

EXAMPLE 1: **CHI01** is a constraint for the Channel Identification IE.

EXAMPLE 2: **CAUX1** is a constraint of the Cause test suite type containing an error (reserved value of location).

#### 7.6.2 ASP constraints

The identifier for an ASP constraint is the abbreviation for the ASP. (There is never more than one constraint for each ASP).

EXAMPLE 1: **DLRQ**, is a generic constraint for the DL\_DAT\_REQ primitive, for sending any PDU to the IUT.

EXAMPLE 2: **DLIN**, is a generic constraint for the DL\_DAT\_IND primitive for receiving any PDU from the IUT.

#### 7.6.3 PDU constraints

PDU constraint identifiers consist of the abbreviation for the PDU followed by two digits for a valid constraint or one upper case letter (X or Y) and one digit for an erroneous constraint. The last digit is odd for constraints for messages sent by the tester and even for constraints for messages received by the tester.

EXAMPLE 1: **ALEX1** indicates a constraint for an ALERTING message containing an error (invalid Channel ID IE contents) which is to be sent to the IUT.

EXAMPLE 2: **ALE02** indicates a constraint for a valid ALERTING message which has been received from the IUT.

#### 7.6.4 CM constraints

The identifier of a Coordination Message constraint is an abbreviation of the CM type in upper case.

EXAMPLE: **RDY** is a constraint of the **READY** Coordination Message.

#### 7.7 Dynamic part

##### 7.7.1 Test Case identifiers

The Test Case identifier is an 8 digit alphanumeric code, as described below:

- characters 1-2: 'TC';
  - digit 3: 2nd level of TSS; <u>
  - digit 4: 3rd level of TSS; <v>
  - digit 5: 4th level of TSS; <w>
  - digit 6: 5th level of TSS; <x>
  - characters 7-8: letters identifying the Test Case. <yz>
- 
- <u> =
    - 0: Protocol control
    - 1: call control Originating
    - 2: call control Terminating
    - 3: call control Transit
    - 4: call control Outgoing gateway
    - 5: call control Incoming gateway
  - <v> =
    - 0: basic interconnection tests
    - 1: capability tests
    - 2: valid behaviour tests
    - 3: Invalid behaviour test
    - 4: inopportune behaviour tests
    - 5: timers tests
  - <w> =
    - 0: State Events transitions
    - 1: Parameter Variations
  - <x> =
    - 0: Call Establishing
    - 1: Call Clearing
    - 2: Message Segmentation
    - 3: STATUS procedures
    - 4: Layer Management
  - <yz> = 'AA ' -> 'ZZ'

EXAMPLE 1: TC2211KW is the number of **test case KW**, for the **terminating** side, to test the **valid behaviour** of the IUT, with **parameter variations**, during **call clearing**.

EXAMPLE 2: TC2211KU is the number of **test case KU**, for the **terminating** side, to test the **valid behaviour** of the IUT, with **parameter variations**, during **call clearing**.

##### 7.7.2 Test Step identifier

The Test Step identifier is a string in lower case consisting of one or more components separated by underscore characters ('\_').

The following components may appear in test step identifiers in this order:

"pre" Preamble

"check_state"	Check state
"check_2state"	Check state with two alternative states.
"post"	Postamble
"passive"	Test step run on interface which is not the focus of a transit test case
"receive"	Test step for receiving a message (e.g. segmented)
"mtc", "ptcx" or "ptcy"	Test component (for synchronisation test steps)
"tr"	Transit test step (in some cases this is implied from the presence of x or y)
"seg", "lseg"	Test step for PCO LSEG
"status_enq"	Test step to cause IUT to send a STATUS ENQUIRY
"clear"	Test step to clear the call from one side of a transit PINX
"x" or "y"	Interface the test step is run on (implies transit)
"s0", "s1" etc.	End call state of test step
"rest1"	End layer management state of the test step
"a"	No synchronisation at end of test step (transit only)

NOTE: There is no underscore separating "x" or "y", the state and "a".

"ic"	Incoming call
"oc"	Outgoing call
"excl"	Exclusive (Channel identification)
"pref"	Preferred (Channel identification)
"busy_chan"	Make channel(s) busy
"param"	Parameterised
"sync"	Synchronise (only)

EXAMPLE 1: **pre\_tr\_xs25** indicates that this test step is a preamble used in the transit test cases, to bring interface X to state 25.

EXAMPLE 2: **check\_state\_y** indicates that this test step is used to check that the interface Y of the IUT is in a particular state.

EXAMPLE 3: **ptcx\_sync** indicates that this test step is used to synchronise the parallel test component for the interface X, with the master test component.

### 7.7.3 Default identifier

The Default identifiers begin with the prefix "def\_", followed by a string in lower case, representing the place where the default tree is used.

EXAMPLE 1: **def\_steps** is the general default tree for the test steps.

EXAMPLE 2: **def\_post** is the default tree for the postambles.

EXAMPLE 3: **def\_pre** is the default tree for the preambles.

EXAMPLE 4: **def\_pre\_x** is the default tree for the transit preambles occurring on interface X

EXAMPLE 5: **def\_mtc** is the default tree for the transit test cases, describing the behaviour of the Master Test Component.

### 7.8 Notation

The ATS is written in TTCN according to ISO/IEC 9646-3 [5] including Amendment 1 with the following differences:

- 1) The metatype "PDU" is used as the type of arguments to Test Suite Operations.
- 2) OTHERWISE in a default can lead to Inconclusive as well as Fail verdicts.



- 3) The procedural definition notation defined in PDAM 2 to ISO/IEC 9646-3 [5] is used in some Test Suite Operations. Where this is used comments are identified by "--" instead of "/\* ... \*/" so that the notation conforms to the syntax of ISO/IEC 9646-3 [5] without the amendment.

## **8 Test case and test purpose mapping**

There is a one-to-one mapping between the test cases and the final derived test purposes in prETS 300 805-1 [2], and they both have the same identifier.

**Annex A (normative): Partial PIXIT proforma**

Notwithstanding the provisions of the copyright clause related to the text of this ETS, ETSI grants that users of this ETS may freely reproduce the PIXIT proforma in this annex so that it can be used for its intended purposes and may further publish the completed PIXIT.

The PIXIT Proforma is based on ISO/IEC 9646-5 [8]. Any additional information needed can be found in that international standard document.

**A.1 Identification summary**

PIXIT Number:	
Test Laboratory Name:	
Date of Issue:	
Issued to:	

**A.2 ATS summary**

Protocol Specification:	ETS 300 172 [1]
Protocol to be tested:	PSS1, Circuit Mode Basic Services
ATS Specification:	prETS 300 805-2
Abstract Test Method for the Message Segmentation and the Protocol Discriminator Filter:	Embedded variant of the Remote Test Method with no UT
Abstract Test Method for Transit Call Control:	Multi-Party Test Method with no UT
Abstract Test Method for non-Transit Call Control and Other Protocol Control Functions:	Remote Test Method

**A.3 Test laboratory**

Test Laboratory Identification:	
Test Laboratory Manager:	
Means of Testing:	

**A.4 Client identification**

Client Identification:	
Client Test manager:	
Test Facilities required:	

**A.5 SUT**

Name:	
Version:	
SCS Number:	
Machine configuration:	
Operating System Identification:	
IUT Identification:	
PICS Reference for IUT:	ETS 300 172 [1] Annex A
Limitations of the SUT:	
Environmental Conditions:	

## A.6 Protocol layer information

### A.6.1 Protocol identification

Name:	PSS1 Circuit Mode Basic Services
Version:	
PICS References:	ETS 300 172 [1] Annex A

### A.6.2 IUT information

NOTE 1: For numbers sent by the IUT, only the digit fields of the Called Party Number are required.

NOTE 2: For numbers sent to the IUT, the complete Called Party Number IE should be supplied.

#### A.6.2.1 General information

##### A.6.2.1.1 General Configuration

One interface of the IUT should be designated X, this interface is used for all non-transit test cases and is used for the incoming side for Transit test cases. If the IUT is a transit PINX then another interface should be designated Y, this is used for the outgoing side of Transit tests.

**Table A.1: General Configuration**

Item	Action	Action Possible? / Item Supported? Y/N	Action taken/Value
1	How can the IUT be configured as A side ?		
2	How can the IUT be configured as B side ?		
3	How many Information channels does the IUT support on each interface?		
4	Specify the numbers of two supported information channels.-		
5	Specify the number of one information channel which is not supported.		
6	Specify a valid Bearer Capability IE.		
7	Specify how to identify interface X		
8	Specify how to identify interface Y		

**A.6.2.1.2 Addressing**

For each of the roles Terminating, Transit and Outgoing gateway which the IUT supports an appropriate number should be specified. For a terminating PINX this should be the number of a terminal attached to the IUT, for a transit PINX it should be a number routed on to interface Y and for an outgoing gateway it should be a number routed to the other network. In addition a valid number is required for Protocol Control tests (which may be the same as that for one of the roles) and an unassigned number should be given.

In each case the numbering plan identifier, type of number and number of digits should be given. The number of digits should be entered into columns A to E (excluding those which are shaded) such that the description of the number in the heading of each column is satisfied by the number formed by the digits in that column and the columns to the left of it, (i.e. each column except the leftmost contains digits to be appended to those in the columns to the left.). Depending on the numbering plan some columns may be empty, however as many columns as possible should be filled and at least one entry in column D or E is required for each supported role.

If a box marked \* is empty, and the IUT supports a number which satisfies the description in the heading of that column, but which cannot be formed by appending digits to the number to the left of it, this number should be given separately.

**EXAMPLE**

**Table A.2: Addressing**

	Role	NPI	TON	A IUT can determine that number is Terminating, Transit or Outgoing	B IUT can determine where to route the number to.	C IUT can determine that the number is incomplete ...	D IUT cannot determine whether or not the number is complete	E IUT can determine that the number is complete or unassigned
3	Transit	PNP	unknown	8	7	65	-	4

In the table above the IUT interprets the numbers given as follows:

- 8                   it is a transit number
- 87                 it is a transit number which is to be routed to interface Y
- 876, 8765       that these numbers are incomplete
- 87654            the IUT can determine that this number is complete.

The distribution of the digits 765 between columns B and C is in this case arbitrary. These digits are spread over the two columns to maximise the number of entries.

	Role	NPI	TON	A IUT can determine that number is Terminating, Transit or Outgoing	B IUT can determine where to route the number to.	C IUT can determine that the number is incomplete and cannot determine that it is unassigned	D IUT cannot determine whether or not the number is complete	E IUT can determine that the number is complete or unassigned
1	Protocol Control						*	*
2	Terminating							
3	Transit							
4	Outgoing							
5	Unassigned							

Table A.3: Addressing - supplementary information

Item	What is the Party Category, if supported, associated with the number specified in table 1.2 above for the IUT as a...	Action Possible? / Item Supported? Y/N	Action taken/Value
1	Terminating PINX.		
2	Outgoing gateway PINX.		

A.6.2.2 Clearing Procedures

Table A.4.: Clearing Procedures

Item	Action What actions, if possible, have to be taken to initiate call clearing,...	Action Possible? / Item Supported? Y/N	Action taken/Value
1	...in state 1 ?		
2	...in state 2 ?		
3	...in state 3 ?		
4	...in state 4 ?		
5	...in state 7 ?		
6	...in state 8 ?		
7	...in state 9 ?		
8	...in state 10 ?		
9	...in state 25 ?		

## A.6.2.3 General Sending of Messages

NOTE 1: Where a question refers to certain information elements being present in a message this does not imply that other IEs may not be present. If any are sent then they will be ignored.

NOTE 2: If a message is sent automatically in a particular state, then this should be stated in the question concerned with the sending of that message, with the time taken included.

Table A.5: Sending of SETUP Message

Item	Action Sending of SETUP What actions, if possible, have to be taken to cause the IUT, as an Originating or Incoming Gateway PINX, to send a SETUP message...	Action Possible? / Item Supported? Y/N	Action taken/Value
1	...without any restriction on which optional IEs are present?		
2	...containing a Sending Complete IE?		
3	...containing a Channel Identification IE with Preferred/Exclusive field encoded as preferred?		
4	...containing a Channel Identification IE with Preferred/Exclusive field encoded as exclusive?		
5	...containing a Called Party Number IE not containing a complete number, but with further address information available for use in overlap sending?		
6	...containing a Bearer Capability IE encoded for 64 Kbit/s Unrestricted Digital Information?		
7	...containing a Bearer Capability IE encoded for 64 Kbit/s Speech?		
8	...containing a Bearer Capability IE encoded for 64 Kbit/s 3,1 kHz audio?		
9	...containing a Bearer Capability IE encoded for 64 Kbit/s unrestricted digital information with tones and announcements?		
10	...containing a Called Party Number IE which contains a complete number?		
11	Specify this complete number sent according to (10).		

Table A6: Sending of ALERTING Message

Item	Action Sending of ALERTING What actions, if possible, have to be taken to cause the IUT, as a Terminating or Outgoing Gateway PINX, to send an ALERTING message...	Action Possible? / Item Supported? Y/N	Action taken/Value
1	...without any restriction on which optional IEs are present, in state 9?		
2	...containing a Progress Indicator IE, in state 9?		
3	...without any restriction on which optional IEs are present, in state 25?		

**Table A.7: Sending of PROGRESS Message**

Item	Action Sending of PROGRESS What actions, if possible, have to be taken to cause the IUT to send a PROGRESS message,...	Action Possible? / Item Supported? Y/N	Action taken/Value
1	...in state 7?		
2	...in state 9?		
3	...in state 10?		
4	...in state 25		

**Table A.8: Sending of CONNECT Message**

	Sending of CONNECT What actions, if possible, have to be taken to cause the IUT, as a Terminating or Outgoing Gateway PINX, to send a CONNECT message...	Action Possible? / Item Supported? Y/N	Action taken/Value
1	...without any restriction on which optional IEs are present, in state 7?		
2	...without any restriction on which optional IEs are present, in state 9?		
3	...containing a Progress Indicator IE, in state 7?		
4	...containing a Progress Indicator IE, in state 9?		

**A.6.2.4 Originating PINX**

**Table A.9: Originating PINX**

Item	Action Sending of SETUP What actions, if possible, have to be taken to cause the IUT, as an Originating PINX, to send a SETUP message...	Action Possible? / Item Supported? Y/N	Action taken/Value
1	...without any restriction on which optional IEs are present?		
2	...containing a Calling Party Subaddress IE?		
3	...containing a Called Party Subaddress IE?		
4	...containing a Low Layer Compatability IE?		
5	...containing a High Layer Compatability IE?		
6	...without the Calling/Connected Line Identification Restriction supplementary service invoked ?		
7	...containing a Transit Counter IE?		
8	...containing a Party Category IE?		

A.6.2.5 Terminating PINX

Table A.10: Sending of ALERTING

Item	Action Sending of ALERTING What actions, if possible, have to be taken to cause the IUT, as a Terminating PINX, to send an ALERTING message...	Action Possible? / Item Supported? Y/N	Action taken/Value
1	...containing a Party Category IE, in state 9?		

Table A.11: Sending of CONNECT

Item	Action Sending of CONNECT What actions, if possible, have to be taken to cause the IUT, as a Terminating PINX, to send a CONNECT message...	Action Possible? / Item Supported? Y/N	Action taken/Value
1	...without any restriction on which optional IEs are present, in state 7?		
2	...without any restriction on which optional IEs are present, in state 9?		
3	...without the Calling/Connected Line Identification Restriction supplementary service being invoked, in state 7?		
4	...containing a Connected Subaddress IE in state 7?		
5	...containing a Connected Subaddress IE in state 9?		
6	...containing a Lower Layer Compatibility IE in state 7?		
7	...containing a Lower Layer Compatibility IE in state 9?		
8	...containing a Party Category IE in state 7?		
9	...containing a Party Category IE in state 9?		

Table A.12: In-band Tones and Announcements

Item	Action In-band Tones and Announcements generated by the PINX.	Action Possible? / Item Supported? Y/N	Action taken/Value
1	How, if possible, can the IUT, as a Terminating PINX, be caused to generate an in-band tone or announcement associated with call clearing and in which protocol control state(s)?		
2	What is the maximum duration of the in-band tone or announcement associated with call clearing as a Terminating PINX?		



A.6.2.6 Incoming Gateway PINX

Table A13: Incoming Gateway PINX

Item	Action Sending of SETUP What actions, if possible, have to be taken to cause the IUT, as an Incoming Gateway PINX, to send a SETUP message...	Action Possible? / Item Supported? Y/N	Action taken/Value
1	...containing a Called Party Subaddress IE?		
2	...containing a Calling Party Subaddress IE?		
3	...containing a Low Layer Compatability IE?		
4	...containing a High Layer Compatability IE?		
5	...containing a Sending complete IE?		
6	...containing a Progress Indicator IE?		
7	...containing a Transit Counter IE?		
8	...containing a Party Category IE?		
9	...containing a Calling Party Number IE?		

A.6.2.7 Outgoing Gateway PINX

Table A.14: Sending of ALERTING

Item	Action Sending of ALERTING What actions, if possible, have to be taken to cause the IUT, as an Outgoing Gateway PINX, to send an ALERTING message...	Action Possible? / Item Supported? Y/N	Action taken/Value
1	...without any restriction on which optional IEs are present?		
2	...containing a Party Category IE ?		

Table A.15: Sending of CONNECT

Item	Action Sending of CONNECT What actions, if possible, have to be taken to cause the IUT, as an Outgoing Gateway PINX, to send an CONNECT message...	Action Possible? / Item Supported? Y/N	Action taken/Value
1	...without any restriction on which optional IEs are present?		

## A.6.2.8 Transit PINX

Table A.16: Transit Counter

Item	Action Transit Counter	Action Possible? / Item Supported? Y/N	Action taken/Value
1	What is the acceptable limit of the Transit Counter, or, if it is variable, how can it be set?		
2	Does the implementation include a Transit Counter IE in a SETUP message it sends as a transit PINX if this IE is not present in the incoming SETUP message?		

Table A.17: In-band Tones and Announcements

Item	Action In-band Tones and Announcements generated by the PINX	Action Possible? / Item Supported? Y/N	Action taken/Value
1	How, if possible, can the IUT as a Transit PINX, be caused to generate an in-band tone or announcement associated with call clearing towards the preceding PINX, and in which transit call control state(s)?		
2	What is the maximum duration of the in-band tone or announcement associated with call clearing sent towards the preceding PINX ?		
3	Does the IUT send a PROGRESS message associated with Tones and Announcements in state TCC_CallActive?		

Table A.18: Relaying of CALL PROCEEDING message

Item	Action Relaying of CALL PROCEEDING message	Action Possible? / Item Supported? Y/N	Action taken/Value
1	Does the IUT, as a Transit PINX, relay the CALL PROCEEDING message ?		

## A.6.2.9 Status Procedure

Table A.19: Status Enquiry Procedure (Implicit Status Enquiry)

NOTE: Implicit STATUS ENQUIRY is only required in states in which the IUT does not send STATUS ENQUIRY on unrecognised message type (Table A.22, item 2) or DL\_EST\_CON (Table A.22, item 1)

Item	Action STATUS ENQUIRY What actions, if possible, have to be taken to cause the IUT to send a STATUS ENQUIRY message...	Action Possible? / Item Supported? Y/N	Action taken/Value
1	...in state 2 ?		
2	...in state 3 ?		
3	...in state 4 ?		
4	...in state 7 ?		
5	...in state 9 ?		
6	...in state 10 ?		
7	...in state 25 ?		

Table A.20: Status Enquiry Procedure (Retransmission)

Item	Action STATUS ENQUIRY	Action Possible? / Item Supported? Y/N	Action taken/Value
1	Does the IUT re-transmit the STATUS ENQUIRY message??		
2	If so what is the maximum number of re-transmissions of a STATUS ENQUIRY message?		

## A.6.2.10 Layer Management

Table A.21: Layer Management

Item	Action RESTART	Action Possible? / Item Supported? Y/N	Action taken/Value
1	How, if possible, can the IUT be caused to send a RESTART message?		
2	Does the IUT re-transmit the RESTART message?		

A.6.2.11 Error Handling

Table A.22: STATUS ENQUIRY

Item	Action STATUS ENQUIRY	Action Possible? / Item Supported? Y/N	Action taken/Value
1	Does the IUT always return a STATUS ENQUIRY message on receipt of DL-ESTABLISH-CONFIRM following SCM malfunction in state 10?		
2	Does the IUT always return a STATUS ENQUIRY message on receiving a message with an unrecognised message type?		

A.6.2.12 Segmentation

Table A.23: Segmentation

Item	Action SCM Information Field	Action Possible? / Item Supported? Y/N	Action taken/Value
1	How (if possible) can a SETUP message exceeding the maximum SCM information field length be sent?		

A.6.2.13 Timers

Table A.24: Timers

Item	Action Timers	Action Possible? / Item Supported? Y/N	Action taken/Value
1	What is the maximum duration of Timer T304?		

A.6.3 Called Party Numbers in the PIXIT

This subclause gives some explanations concerning the numbers used in the PIXIT proforma and the Test Suite Parameters used in the TTCN ATS.

For the purposes of the PIXIT and test suite parameters, a number is usually considered to be **complete** if it is complete according to the numbering plan which the IUT is configured for. A number is considered to be **incomplete** if further digits may be added to make it complete according to the numbering plan.

In some numbering plans the completeness of a number may be meaningless at a Transit or Outgoing Gateway PINX, (e.g. numbers are of variable length and only the terminating PINX, or an exchange in another network has information concerning the length of numbers for its terminals). In these cases a number can be considered complete if it has at least the minimum number of digits possible for a complete number for the appropriate route from the IUT and incomplete if it has less than the maximum

number of digits. In this case it is possible that the same number may be acceptable as both Complete and Incomplete.

A number which the IUT can "**determine to be complete**" is one where the IUT, having received the number, can determine that no more addressing information is required. Typically it sends CALL PROCEEDING, ALERTING or CONNECT but this may not always occur in the transit case. In the case of variable length numbers for Transit and Outgoing Gateway PINXs this may relate only to numbers of the maximum length in the numbering plan (if it occurs at all).

A number which the IUT can "**determine to be incomplete**" is one where the IUT, having received the number, can determine that further addressing information is necessary for the call to be completed.

A (partial) number which the IUT can "**determine where to route to**" is one where the IUT as a transit PINX sends a SETUP on the interface it is routed to, when it receives that number. This may require more digits than are essential in the numbering plan to determine the route, (e.g. if the IUT does not examine the number until a certain number of digits have been received or there is an access code which determines the route, but is not part of the number sent on).

A (partial) number which the IUT can "**determine to be routed to another network**" is one which contains sufficient information in the numbering plan to indicate that, if it is completed to a valid number, it is routed to the other network. This is independent on whether the partial number causes any signalling on the other network.

A (partial) number which the IUT can "**determine to be unassigned**" is one which the IUT cannot route to any terminal, other PINX, or other network, even if additional digits are added. This may be because the numbering plan identified has a value not supported by the IUT, or the number may be unassigned in the IUT configuration.

EXAMPLE:                   The numbering plan for a PINX is:

- 2XXX     Terminals attached to the PINX (all assumed to be assigned);
- 3XXX     Terminals attached to another PINX;
- 9         Access code to public network.

All other numbers are unassigned. The IUT recognises complete internal numbers because they have 4 digits. It does not enforce any length restrictions on numbers routed to the public network.

**2345**, **3456** and **96543** are complete numbers.

**23**, **34** and **96543** are incomplete numbers.

**2345** and **3456** are numbers which the IUT can determine to be complete.

**23** and **34** are numbers which the IUT can determine to be incomplete.

**34** and **3456** contain enough information for routing.

**9** and **96543** may be determined to be routed to another network.

**8** and **456** may be determined to be unassigned.

**96543** may be considered as both a Complete and Incomplete number, although it cannot be determined to be either complete or incomplete.

**Annex B (normative): Protocol Conformance Test Report (PCTR) Proforma for PSS1\_BC Layer**

Notwithstanding the provisions of the copyright clause related to the text of this ETS, ETSI grants that users of this ETS may freely reproduce the PCTR proforma in this annex so that it can be used for its intended purposes and may further publish the completed PCTR.

*ED NOTE: This PCTR proforma contains text reproduced from ISO/IEC 9646-5. This includes references to sections of the report, rather than clauses and subclauses, and also contains text in italics. This has been retained, although it does not conform to the PNE rules and ETSI stylesheet.*

The PCTR Proforma is based on ISO/IEC 9646-5 [8]. Any additional information needed can be found in that document.

Text in italics is for guidance purposes only, and is not to be included in the actual PCTR.

**B.1 Identification summary**

**B.1.1 Protocol conformance test report**

PCTR Number:	
PCTR Date:	
Test Laboratory	
Accreditation status:	
Accreditation reference:	
Technical Authority:	
Job Title:	
Signature:	
Test Laboratory Manager:	
Signature:	

**B.1.2 IUT identification**

Name:	
Version:	
Protocol specification:	ETS 300 172 [1]
PICS:	
	ETS 300 172 [1] Annex A Ref. <i>Ref. to attached document.</i>

**B.1.3 Testing environment**

PIXIT Number:	prETS 300 805-2 Annex A ref. <i>Ref. to attached doc.</i>
ATS Specification:	prETS 300 805-2
Abstract Test Method for the Message Segmentation and the Protocol Discriminator Filter:	Remote test method, Embedded variant with no UT
Abstract Test Method for Transit Call Control:	Multi-Party Test Method with no UT
Transit Call Control and Other Protocol Control Functions:	Remote Test Method
Means of Testing identification:	
Period of testing:	
Conformance Log reference(s):	
Retention Date for Log reference(s):	

**B.1.4 Limits and reservation**

*Additional information relevant to the technical contents or further use of the test report, or the rights and obligations of the test laboratory and the client, may be given here. Such information may include restriction on the publication of the report.*

.....  
.....  
.....  
.....  
.....

The order of test cases listed in section 6 of this PCTR corresponds to the ordering of test cases defined in the ATS referenced in section 1.3. This does not indicate that the test cases were executed in this order.

The test results presented in this test report apply only to the particular IUT declared in section 1.2 of this PCTR, for functionality described in the relevant PICSs attached to this PCTR, as presented for test in the period declared in section 1.3 and configured as declared in the relevant PIXITs attached to this PCTR. This PCTR shall not be reproduced except in full together with its attached PICSs and PIXITs.

**B.1.5 Comments**

*Additional comments may be given by either the client or the test laboratory on any of the contents of the PCTR, for example, to note disagreement between the two parties.*

.....  
.....  
.....  
.....  
.....

**B.2 IUT Conformance status**

This IUT has/has not been shown by conformance assessment to be non conforming to the referenced base specification.

*Strike the appropriate words in this sentence. If the PICS for this IUT is consistent with the static conformance requirements (as specified in section 3 in this report) and there are no "FAIL" verdicts to be recorded (in section 6) strike the words "has or" otherwise strike the words "or has not".*

**B.3 Static conformance summary**

The PICS for this IUT is/is not consistent with the static conformance requirements in the specified protocol.

*Strike the appropriate words in this sentence.*

**B.4 Dynamic conformance summary**

The test campaign did/did not reveal errors in the IUT.

*Strike the appropriate words in this sentence. If there are no "FAIL" verdicts to be recorded (in section 6 of this report) strike the words "did /" otherwise strike the words "/ did not".*





## B.6 Test campaign report

*SG NOTE: This table has been completely regenerated, therefore revision marks are not shown.*

ATS Reference	Selected ?	Run ?	Verdict	Observations (Reference to any observations made in clause 7)
TC0000JU	Yes/No	Yes/No		
TC0000JV	Yes/No	Yes/No		
TC0001DI	Yes/No	Yes/No		
TC0001DJ	Yes/No	Yes/No		
TC0010AJ	Yes/No	Yes/No		
TC0010AK	Yes/No	Yes/No		
TC0100AA	Yes/No	Yes/No		
TC0100AE	Yes/No	Yes/No		
TC0100BF	Yes/No	Yes/No		
TC0100BH	Yes/No	Yes/No		
TC0100BJ	Yes/No	Yes/No		
TC0100BK	Yes/No	Yes/No		
TC0100BL	Yes/No	Yes/No		
TC0100BN	Yes/No	Yes/No		
TC0100BO	Yes/No	Yes/No		
TC0100BV	Yes/No	Yes/No		
TC0100JH	Yes/No	Yes/No		
TC0100JI	Yes/No	Yes/No		
TC0100JK	Yes/No	Yes/No		
TC0100JM	Yes/No	Yes/No		
TC0100JO	Yes/No	Yes/No		
TC0100JS	Yes/No	Yes/No		
TC0100KC	Yes/No	Yes/No		
TC0100XA	Yes/No	Yes/No		
TC0101CS	Yes/No	Yes/No		
TC0101CW	Yes/No	Yes/No		
TC0110AB	Yes/No	Yes/No		
TC0110AC	Yes/No	Yes/No		
TC0110AD	Yes/No	Yes/No		
TC0110AL	Yes/No	Yes/No		
TC0110AM	Yes/No	Yes/No		
TC0110BE	Yes/No	Yes/No		
TC0110BS	Yes/No	Yes/No		
TC0110CB	Yes/No	Yes/No		
TC0110JD	Yes/No	Yes/No		
TC0110XD	Yes/No	Yes/No		
TC0110XE	Yes/No	Yes/No		
TC0110XF	Yes/No	Yes/No		
TC0110YG	Yes/No	Yes/No		
TC0111CQ	Yes/No	Yes/No		
TC0111CX	Yes/No	Yes/No		
TC0112EL	Yes/No	Yes/No		
TC0112ES	Yes/No	Yes/No		
TC0112ET	Yes/No	Yes/No		
TC0112EU	Yes/No	Yes/No		
TC0112FM	Yes/No	Yes/No		
TC0113IG	Yes/No	Yes/No		
TC0113ST	Yes/No	Yes/No		
TC0113SZ	Yes/No	Yes/No		
TC0114TE	Yes/No	Yes/No		
TC0114TF	Yes/No	Yes/No		
TC0200BB	Yes/No	Yes/No		

ATS Reference	Selected ?	Run ?	Verdict	Observations (Reference to any observations made in clause 7)
TC0200BC	Yes/No	Yes/No		
TC0200BD	Yes/No	Yes/No		
TC0200BQ	Yes/No	Yes/No		
TC0200BX	Yes/No	Yes/No		
TC0200JF	Yes/No	Yes/No		
TC0200JG	Yes/No	Yes/No		
TC0200JL	Yes/No	Yes/No		
TC0200JP	Yes/No	Yes/No		
TC0200JW	Yes/No	Yes/No		
TC0200JX	Yes/No	Yes/No		
TC0200JY	Yes/No	Yes/No		
TC0200JZ	Yes/No	Yes/No		
TC0200KA	Yes/No	Yes/No		
TC0200KB	Yes/No	Yes/No		
TC0200XB	Yes/No	Yes/No		
TC0200XC	Yes/No	Yes/No		
TC0201CG	Yes/No	Yes/No		
TC0201CI	Yes/No	Yes/No		
TC0201CL	Yes/No	Yes/No		
TC0201CN	Yes/No	Yes/No		
TC0201CP	Yes/No	Yes/No		
TC0201CR	Yes/No	Yes/No		
TC0201CU	Yes/No	Yes/No		
TC0201DK	Yes/No	Yes/No		
TC0201XL	Yes/No	Yes/No		
TC0201XM	Yes/No	Yes/No		
TC0201XN	Yes/No	Yes/No		
TC0203SB	Yes/No	Yes/No		
TC0203SC	Yes/No	Yes/No		
TC0203SD	Yes/No	Yes/No		
TC0203SE	Yes/No	Yes/No		
TC0203SF	Yes/No	Yes/No		
TC0203SG	Yes/No	Yes/No		
TC0203SJ	Yes/No	Yes/No		
TC0203SK	Yes/No	Yes/No		
TC0203SL	Yes/No	Yes/No		
TC0203SM	Yes/No	Yes/No		
TC0203SN	Yes/No	Yes/No		
TC0203SO	Yes/No	Yes/No		
TC0204TC	Yes/No	Yes/No		
TC0210AI	Yes/No	Yes/No		
TC0210AZ	Yes/No	Yes/No		
TC0210BA	Yes/No	Yes/No		
TC0210BG	Yes/No	Yes/No		
TC0210BT	Yes/No	Yes/No		
TC0210BU	Yes/No	Yes/No		
TC0210BW	Yes/No	Yes/No		
TC0210BY	Yes/No	Yes/No		
TC0210BZ	Yes/No	Yes/No		
TC0210CA	Yes/No	Yes/No		
TC0210CC	Yes/No	Yes/No		
TC0210CD	Yes/No	Yes/No		
TC0210CE	Yes/No	Yes/No		
TC0210JE	Yes/No	Yes/No		
TC0210JR	Yes/No	Yes/No		
TC0210KM	Yes/No	Yes/No		

ATS Reference	Selected ?	Run ?	Verdict	Observations (Reference to any observations made in clause 7)
TC0210KN	Yes/No	Yes/No		
TC0210KP	Yes/No	Yes/No		
TC0210KQ	Yes/No	Yes/No		
TC0210KR	Yes/No	Yes/No		
TC0210KS	Yes/No	Yes/No		
TC0210KT	Yes/No	Yes/No		
TC0211CF	Yes/No	Yes/No		
TC0211CH	Yes/No	Yes/No		
TC0211CJ	Yes/No	Yes/No		
TC0211CK	Yes/No	Yes/No		
TC0211CM	Yes/No	Yes/No		
TC0211CO	Yes/No	Yes/No		
TC0211DL	Yes/No	Yes/No		
TC0212EM	Yes/No	Yes/No		
TC0212EN	Yes/No	Yes/No		
TC0212EO	Yes/No	Yes/No		
TC0212EP	Yes/No	Yes/No		
TC0212EQ	Yes/No	Yes/No		
TC0212ER	Yes/No	Yes/No		
TC0212YE	Yes/No	Yes/No		
TC0213EB	Yes/No	Yes/No		
TC0213EF	Yes/No	Yes/No		
TC0213EG	Yes/No	Yes/No		
TC0213EH	Yes/No	Yes/No		
TC0213EI	Yes/No	Yes/No		
TC0213EK	Yes/No	Yes/No		
TC0213SA	Yes/No	Yes/No		
TC0213SP	Yes/No	Yes/No		
TC0213SQ	Yes/No	Yes/No		
TC0213SR	Yes/No	Yes/No		
TC0213SS	Yes/No	Yes/No		
TC0213SU	Yes/No	Yes/No		
TC0213SV	Yes/No	Yes/No		
TC0213SX	Yes/No	Yes/No		
TC0213SY	Yes/No	Yes/No		
TC0213WA	Yes/No	Yes/No		
TC0213WB	Yes/No	Yes/No		
TC0213WC	Yes/No	Yes/No		
TC0214TA	Yes/No	Yes/No		
TC0214TD	Yes/No	Yes/No		
TC0214TG	Yes/No	Yes/No		
TC0214TH	Yes/No	Yes/No		
TC0214TI	Yes/No	Yes/No		
TC0214TJ	Yes/No	Yes/No		
TC0214TK	Yes/No	Yes/No		
TC0214TL	Yes/No	Yes/No		
TC0214YH	Yes/No	Yes/No		
TC0214YI	Yes/No	Yes/No		
TC0300AV	Yes/No	Yes/No		
TC0301HJ	Yes/No	Yes/No		
TC0301HK	Yes/No	Yes/No		
TC0301HR	Yes/No	Yes/No		
TC0301HS	Yes/No	Yes/No		
TC0301XP	Yes/No	Yes/No		
TC0301XR	Yes/No	Yes/No		
TC0302FG	Yes/No	Yes/No		

ATS Reference	Selected ?	Run ?	Verdict	Observations (Reference to any observations made in clause 7)
TC0302FH	Yes/No	Yes/No		
TC0302FJ	Yes/No	Yes/No		
TC0302FL	Yes/No	Yes/No		
TC0310AW	Yes/No	Yes/No		
TC0310FP	Yes/No	Yes/No		
TC0310FQ	Yes/No	Yes/No		
TC0310FR	Yes/No	Yes/No		
TC0310FS	Yes/No	Yes/No		
TC0310FT	Yes/No	Yes/No		
TC0310FU	Yes/No	Yes/No		
TC0310GL	Yes/No	Yes/No		
TC0310GM	Yes/No	Yes/No		
TC0310GO	Yes/No	Yes/No		
TC0310GQ	Yes/No	Yes/No		
TC0310GR	Yes/No	Yes/No		
TC0310GS	Yes/No	Yes/No		
TC0310GZ	Yes/No	Yes/No		
TC0310HE	Yes/No	Yes/No		
TC0310HF	Yes/No	Yes/No		
TC0310HT	Yes/No	Yes/No		
TC0310HU	Yes/No	Yes/No		
TC0310HV	Yes/No	Yes/No		
TC0310HW	Yes/No	Yes/No		
TC0310XX	Yes/No	Yes/No		
TC0311FO	Yes/No	Yes/No		
TC0311FX	Yes/No	Yes/No		
TC0311GP	Yes/No	Yes/No		
TC0311GT	Yes/No	Yes/No		
TC0311GU	Yes/No	Yes/No		
TC0311GV	Yes/No	Yes/No		
TC0311GW	Yes/No	Yes/No		
TC0311GX	Yes/No	Yes/No		
TC0311GY	Yes/No	Yes/No		
TC0311HB	Yes/No	Yes/No		
TC0311HC	Yes/No	Yes/No		
TC0311HD	Yes/No	Yes/No		
TC0311HH	Yes/No	Yes/No		
TC0311HI	Yes/No	Yes/No		
TC0311HL	Yes/No	Yes/No		
TC0311HM	Yes/No	Yes/No		
TC0311HN	Yes/No	Yes/No		
TC0311HO	Yes/No	Yes/No		
TC0311HP	Yes/No	Yes/No		
TC0311HQ	Yes/No	Yes/No		
TC0311XO	Yes/No	Yes/No		
TC0311XQ	Yes/No	Yes/No		
TC0312EV	Yes/No	Yes/No		
TC0312EX	Yes/No	Yes/No		
TC0312EY	Yes/No	Yes/No		
TC0312FI	Yes/No	Yes/No		
TC0312FK	Yes/No	Yes/No		
TC0312YF	Yes/No	Yes/No		
TC0314GN	Yes/No	Yes/No		
TC0314HA	Yes/No	Yes/No		
TC0314YD	Yes/No	Yes/No		
TC0400GB	Yes/No	Yes/No		

ATS Reference	Selected ?	Run ?	Verdict	Observations (Reference to any observations made in clause 7)
TC0400GF	Yes/No	Yes/No		
TC0400GG	Yes/No	Yes/No		
TC0400HX	Yes/No	Yes/No		
TC0400HY	Yes/No	Yes/No		
TC0401FY	Yes/No	Yes/No		
TC0401FZ	Yes/No	Yes/No		
TC0401GH	Yes/No	Yes/No		
TC0401GI	Yes/No	Yes/No		
TC0401GJ	Yes/No	Yes/No		
TC0401GK	Yes/No	Yes/No		
TC0401XS	Yes/No	Yes/No		
TC0401XT	Yes/No	Yes/No		
TC0402FA	Yes/No	Yes/No		
TC0402FC	Yes/No	Yes/No		
TC0402FE	Yes/No	Yes/No		
TC0402FF	Yes/No	Yes/No		
TC0410AY	Yes/No	Yes/No		
TC0410IA	Yes/No	Yes/No		
TC0410IB	Yes/No	Yes/No		
TC0410IC	Yes/No	Yes/No		
TC0410YA	Yes/No	Yes/No		
TC0410YB	Yes/No	Yes/No		
TC0410YC	Yes/No	Yes/No		
TC0411FV	Yes/No	Yes/No		
TC0411FW	Yes/No	Yes/No		
TC0412EW	Yes/No	Yes/No		
TC0412EZ	Yes/No	Yes/No		
TC0412FB	Yes/No	Yes/No		
TC0412FD	Yes/No	Yes/No		
TC0414GC	Yes/No	Yes/No		
TC0500AG	Yes/No	Yes/No		
TC0501CY	Yes/No	Yes/No		
TC0501CZ	Yes/No	Yes/No		
TC0502FN	Yes/No	Yes/No		
TC0510AF	Yes/No	Yes/No		
TC0510AH	Yes/No	Yes/No		
TC0510BI	Yes/No	Yes/No		
TC0510BM	Yes/No	Yes/No		
TC0510BP	Yes/No	Yes/No		
TC0510JJ	Yes/No	Yes/No		
TC0510KD	Yes/No	Yes/No		
TC0511CV	Yes/No	Yes/No		
TC0514TB	Yes/No	Yes/No		
TC1110AN	Yes/No	Yes/No		
TC1110AR	Yes/No	Yes/No		
TC1110AS	Yes/No	Yes/No		
TC1110AT	Yes/No	Yes/No		
TC1110AU	Yes/No	Yes/No		
TC1210AO	Yes/No	Yes/No		
TC2000JB	Yes/No	Yes/No		
TC2210JC	Yes/No	Yes/No		
TC2210JT	Yes/No	Yes/No		
TC2210KE	Yes/No	Yes/No		
TC2210KG	Yes/No	Yes/No		
TC2210KH	Yes/No	Yes/No		
TC2210KI	Yes/No	Yes/No		

ATS Reference	Selected ?	Run ?	Verdict	Observations (Reference to any observations made in clause 7)
TC2210KJ	Yes/No	Yes/No		
TC2210KK	Yes/No	Yes/No		
TC2210KL	Yes/No	Yes/No		
TC2210XJ	Yes/No	Yes/No		
TC2210XK	Yes/No	Yes/No		
TC2211KU	Yes/No	Yes/No		
TC2211KW	Yes/No	Yes/No		
TC2211KX	Yes/No	Yes/No		
TC3000LA	Yes/No	Yes/No		
TC3111NK	Yes/No	Yes/No		
TC3111NW	Yes/No	Yes/No		
TC3200LH	Yes/No	Yes/No		
TC3200LJ	Yes/No	Yes/No		
TC3210LB	Yes/No	Yes/No		
TC3210LC	Yes/No	Yes/No		
TC3210LD	Yes/No	Yes/No		
TC3210LE	Yes/No	Yes/No		
TC3210LF	Yes/No	Yes/No		
TC3210LG	Yes/No	Yes/No		
TC3210LI	Yes/No	Yes/No		
TC3210LK	Yes/No	Yes/No		
TC3210LL	Yes/No	Yes/No		
TC3210LM	Yes/No	Yes/No		
TC3210LN	Yes/No	Yes/No		
TC3210LP	Yes/No	Yes/No		
TC3210LQ	Yes/No	Yes/No		
TC3210LR	Yes/No	Yes/No		
TC3210LS	Yes/No	Yes/No		
TC3210LT	Yes/No	Yes/No		
TC3210LU	Yes/No	Yes/No		
TC3210LV	Yes/No	Yes/No		
TC3210LW	Yes/No	Yes/No		
TC3210LX	Yes/No	Yes/No		
TC3210MA	Yes/No	Yes/No		
TC3210MB	Yes/No	Yes/No		
TC3210MC	Yes/No	Yes/No		
TC3210MD	Yes/No	Yes/No		
TC3210ME	Yes/No	Yes/No		
TC3210MF	Yes/No	Yes/No		
TC3210MG	Yes/No	Yes/No		
TC3210MH	Yes/No	Yes/No		
TC3210MJ	Yes/No	Yes/No		
TC3210ML	Yes/No	Yes/No		
TC3210OM	Yes/No	Yes/No		
TC3210ON	Yes/No	Yes/No		
TC3210OO	Yes/No	Yes/No		
TC3210OP	Yes/No	Yes/No		
TC3210OS	Yes/No	Yes/No		
TC3210OU	Yes/No	Yes/No		
TC3210OV	Yes/No	Yes/No		
TC3210OW	Yes/No	Yes/No		
TC3210OX	Yes/No	Yes/No		
TC3210OY	Yes/No	Yes/No		
TC3210OZ	Yes/No	Yes/No		
TC3210PA	Yes/No	Yes/No		
TC3210PB	Yes/No	Yes/No		

ATS Reference	Selected ?	Run ?	Verdict	Observations (Reference to any observations made in clause 7)
TC3210PC	Yes/No	Yes/No		
TC3210PD	Yes/No	Yes/No		
TC3210PE	Yes/No	Yes/No		
TC3210PF	Yes/No	Yes/No		
TC3210PG	Yes/No	Yes/No		
TC3210PH	Yes/No	Yes/No		
TC3210PI	Yes/No	Yes/No		
TC3210PJ	Yes/No	Yes/No		
TC3210PK	Yes/No	Yes/No		
TC3210PL	Yes/No	Yes/No		
TC3210PM	Yes/No	Yes/No		
TC3210PS	Yes/No	Yes/No		
TC3210PT	Yes/No	Yes/No		
TC3210PU	Yes/No	Yes/No		
TC3210PV	Yes/No	Yes/No		
TC3210PW	Yes/No	Yes/No		
TC3210PY	Yes/No	Yes/No		
TC3210PZ	Yes/No	Yes/No		
TC3210QA	Yes/No	Yes/No		
TC3210QB	Yes/No	Yes/No		
TC3210QC	Yes/No	Yes/No		
TC3210QD	Yes/No	Yes/No		
TC3210QJ	Yes/No	Yes/No		
TC3210QK	Yes/No	Yes/No		
TC3210QL	Yes/No	Yes/No		
TC3210RL	Yes/No	Yes/No		
TC3210RM	Yes/No	Yes/No		
TC3211NB	Yes/No	Yes/No		
TC3211NC	Yes/No	Yes/No		
TC3211ND	Yes/No	Yes/No		
TC3211NE	Yes/No	Yes/No		
TC3211NF	Yes/No	Yes/No		
TC3211NG	Yes/No	Yes/No		
TC3211NH	Yes/No	Yes/No		
TC3211NI	Yes/No	Yes/No		
TC3211NJ	Yes/No	Yes/No		
TC3211NL	Yes/No	Yes/No		
TC3211NM	Yes/No	Yes/No		
TC3211NN	Yes/No	Yes/No		
TC3211NO	Yes/No	Yes/No		
TC3211NP	Yes/No	Yes/No		
TC3211NQ	Yes/No	Yes/No		
TC3211NR	Yes/No	Yes/No		
TC3211NS	Yes/No	Yes/No		
TC3211NV	Yes/No	Yes/No		
TC3211NX	Yes/No	Yes/No		
TC3211NY	Yes/No	Yes/No		
TC3211NZ	Yes/No	Yes/No		
TC3211OA	Yes/No	Yes/No		
TC3211OC	Yes/No	Yes/No		
TC4200VC	Yes/No	Yes/No		
TC4210EA	Yes/No	Yes/No		
TC4210VB	Yes/No	Yes/No		
TC4210VD	Yes/No	Yes/No		
TC5000UA	Yes/No	Yes/No		
TC5200UB	Yes/No	Yes/No		





## **Annex C (Normative): Abstract Test Suite (ATS) for PSS1\_BC**

This ATS has been produced using the Tree and Tabular Combined Notation (TTCN) according to ISO/IEC 9646-3 [5].

The ATS was developed on a separate TTCN software tool and therefore the TTCN tables are not completely referenced in the contents table. The ATS itself contains a test suite overview part which provides additional information and references.

### **C.1 The TTCN Graphical form (TTCN.GR)**

The TTCN.GR representation of this ATS is contained in a Postscript file (8052\_\_EP.PS (note 1)) which accompanies this ETS.

### **C.2 The TTCN Machine Processable form (TTCN.MP)**

The TTCN.MP representation corresponding to this ATS is contained in an ASCII file (8052\_EP.MP (note1)) which accompanies this ETS.

NOTE 1: This file is located in an archive file name 8052\_EP.LZH. Other file formats are available on request

NOTE 2: According to ISO/IEC 9646-3 [5], in case of a conflict in interpretation of the operational semantics of TTCN.GR and TTCN.MP, the operational semantics of the TTCN.GR representation takes precedence.

## History

Document history	
July 1996	Public Enquiry PE 110: 1996-07-22 to 1996-11-15