



EUROPEAN
TELECOMMUNICATION
STANDARD

DRAFT
pr **ETS 300 805-1**

July 1996

Source: ETSI TC-ECMA

Reference: DE/ECMA 00109-1

ICS: 35.020

Key words: circuit mode, layer 3, PINX, PISN, QSIG, testing, TSS & TP

**Private Integrated Services Network (PISN);
Inter-exchange signalling protocol;
Circuit mode basic services;
Network Layer (NL);
Part 1: Test Suite Structure and Test Purposes
(TSS & TP)**

ETSI

European Telecommunications Standards Institute

ETSI Secretariat

Postal address: F-06921 Sophia Antipolis CEDEX - FRANCE

Office address: 650 Route des Lucioles - Sophia Antipolis - Valbonne - FRANCE

X.400: c=fr, a=atlas, p=etsi, s=secretariat - **Internet:** secretariat@etsi.fr

Tel.: +33 92 94 42 00 - Fax: +33 93 65 47 16

Copyright Notification: No part may be reproduced except as authorized by written permission. The copyright and the foregoing restriction extend to reproduction in all media.

© European Telecommunications Standards Institute 1996. All rights reserved.

Contents

Foreword	5
1 Scope	7
2 Normative references	7
3 Definitions and abbreviations	8
3.1 Definitions	8
3.2 Abbreviations	9
4 Test Suite Structure (TSS)	9
5 Test Purposes (TP)	11
5.1 Introduction to Test Purposes	11
5.1.1 Test purposes production method	11
5.1.2 STP identifier	12
5.1.3 "Final" derived TP identifier	12
5.1.4 Standard options	13
5.1.5 Message segmentation	13
5.2 Test purpose writing rules	13
5.2.1 Terminating, Originating, Incoming/Outgoing Gateway PINX	13
5.2.2 Transit PINX	14
5.3 Test Purposes	15
5.3.1 Protocol Control requirements for Call Establishment	15
5.3.1.1 Call Request	15
5.3.1.2 Information channel selection	18
5.3.1.3 Overlap Sending and Receiving	20
5.3.1.4 Call Proceeding	21
5.3.1.5 Call Confirmation indication	23
5.3.1.6 Call Connected	23
5.3.1.7 Use of the PROGRESS message	25
5.3.1.8 Call collisions	26
5.3.2 Protocol Control requirements for Call Clearing	29
5.3.2.1 Clearing	29
5.3.2.2 Clear Collision	31
5.3.2.3 Exception conditions	31
5.3.3 Protocol Control requirements for Message Segmentation	32
5.3.3.1 Procedures for segmentation	32
5.3.3.2 Procedures for reassembly	33
5.3.4 Protocol Control requirements for STATUS procedures	38
5.3.4.1 Receiving a STATUS message	38
5.3.4.2 Status enquiry procedure	40
5.3.5 Protocol Control requirements for Layer Management	43
5.3.5.1 Sending a RESTART	43
5.3.5.2 Receipt of RESTART	44
5.3.5.3 Restart Collision	46
5.3.6 Protocol Control requirements for handling of protocol error conditions	47
5.3.6.1 Protocol discriminator error	47
5.3.6.2 Message too short	48
5.3.6.3 Call reference error	48
5.3.6.3.1 Invalid call reference format	48
5.3.6.3.2 Call Reference procedural errors	49
5.3.6.4 Message type or Message sequence errors	50
5.3.6.5 General IE errors	52
5.3.6.5.1 Duplicated IEs	52
5.3.6.5.2 IEs exceeding maximum length	52
5.3.6.6 Mandatory IE errors	53

	5.3.6.6.1	Mandatory IEs missing	53
	5.3.6.6.2	Mandatory IE content error.....	55
	5.3.6.7	Non-mandatory IE errors	56
	5.3.6.7.1	Non-mandatory IE not recognised	56
	5.3.6.7.2	Non-mandatory IE content error.....	59
	5.3.6.8	Signalling Carriage Mechanism reset	59
	5.3.6.9	Signalling Carriage Mechanism failure	60
5.3.7		Originating PINX Call Control requirements	61
5.3.8		Terminating PINX Call Control requirements	62
	5.3.8.1	Call Establishment	63
	5.3.8.2	Call Clearing initiated by the Terminating PINX.....	65
5.3.9		Incoming Gateway PINX Call Control requirements.....	65
	5.3.9.1	Call Establishment	65
5.3.10		Outgoing Gateway PINX Call Control requirements.....	68
	5.3.10.1	Call Establishment	68
5.3.11		Call Control requirements for a Transit PINX	69
	5.3.11.1	Call Establishment	69
	5.3.11.2	Call Clearing.....	78
	5.3.11.2.1	Call clearing not initiated by the transit PINX.....	78
	5.3.11.2.2	Call Clearing initiated by the Transit PINX.....	82
	5.3.11.3	Handling of Basic Call IEs at a Transit PINX	83
5.3.12		Protocol Control requirements for the use of the Signalling Carriage Mechanism	89
5.3.13		Verification of state	89
	5.3.13.1	Protocol Control State	89
	5.3.13.2	Layer Management State.....	89
5.4		Distribution of TPs over Test Suite Structure	90
6		Compliance clause	90
Annex A (informative):		Index of test purposes	92
History			95

Foreword

This draft European Telecommunication Standard (ETS) has been produced by the standardizing Information and Communication Systems Association (ECMA) on behalf of its members and those of the European Telecommunications Standards Institute (ETSI), and is now submitted for the Public Enquiry phase of the ETSI standards approval procedure.

This ETS comprises two parts with the generic title "Private Integrated Services Network (PISN); Inter-exchange signalling protocol; Network Layer (NL); Circuit mode basic services". The title of each part is listed below:

Part 1: "Test Suite Structure and Test Purposes"

Part 2: "Abstract Test Suite Specification"

Proposed transposition dates	
Date of latest announcement of this ETS (doa):	3 months after ETSI publication
Date of latest publication of new National Standard or endorsement of this ETS (dop/e):	6 months after doa
Date of withdrawal of any conflicting National Standard (dow):	6 months after doa

Blank page

1 Scope

This European Telecommunication Standard (ETS) contains the Test Suite Structure (TSS) and Test Purposes (TPs) specification for the Network Layer, Circuit Mode Basic Services of the Inter-exchange signalling protocol for Private Integrated Services Networks (PISN)

The objective of this TSS and TPs specification is to provide conformance tests which give a high probability of inter-operability of the Network Layer. The TSS and TPs specification covers the procedures described in ETS 300 172 [1].

The ISO standard for the methodology of conformance testing (ISO/IEC 9646-1 [4], ISO/IEC 9646-2 [5] and ISO/IEC 9646-3 [6]) is used as basis for the test methodology.

This TSS and TPs specification standard is applicable for the support of Basic Call, at the Q-reference point between Private Integrated Services Network Exchanges (PINXs) connected together within a PISN. The Q reference point is defined in ETS 300 475-1 [7].

2 Normative references

This ETS incorporates by dated and undated reference, provisions from other publications. These normative references are cited in the appropriate places in the text and the publications are listed hereafter. For dated references, subsequent amendments or revisions to of any of these publications apply to this ETS only when incorporated in it by amendment or revision. For undated references the latest edition of the publication referred to applies.

- [1] ETS 300 172 (1995): "Private Integrated Services Network (PISN); Inter-Exchange Signalling Protocol; Circuit Mode Basic Services" [ISO/IEC 11572 (1994) modified].
- [2] ETS 300 239 (1995): "Private Integrated Services Network (PISN); Inter-exchange signalling protocol, Generic functional protocol for the support of supplementary services".
- [3] ETS 300 406 (1995): "Methods for testing and specification (MTS); Protocol and profile conformance testing specification; Standardization Methodology".
- [4] ISO/IEC 9646-1 (1994): "Information technology - Open Systems Interconnection; Conformance testing methodology and framework - Part 1: General concepts".
- [5] ISO/IEC 9646-2 (1994): "Information technology- Open Systems Interconnection; Conformance testing methodology and framework - Part 2: Abstract Test Suite Specification".
- [6] ISO/IEC 9646-3 (1992): "Information technology- Open Systems Interconnection; Conformance testing methodology and framework - Part 3: The Tree and Tabular Combined Notation (TTCN)".
- [7] ETS 300 475-1 (1995): "Private Integrated Services Network (PISN); Reference configuration Part 1: Reference configurations for PISN exchanges (PINXs)".
- [8] CCITT Recommendation I 112 (1988): "Vocabulary of terms for ISDNs".

3 Definitions and abbreviations

3.1 Definitions

For the purposes of this ETS the special terminology defined in CCITT Recommendation I.112 [8] applies. The following definitions also apply:

Abstract Test Suite (ATS): See ISO/IEC 9646-1 [4].

final test purpose: A test purpose focusing on a single conformance requirement, produced before any combining of test purposes. This term is not defined in ISO/IEC 9646-1 [4] but corresponds to the "individual test purpose" referred to in ISO/IEC 9646-2 [5] subclause 10.3.3.

Implementation Under Test (IUT): See ISO/IEC 9646-1 [4].

incoming call: See ETS 300 172 [1].

incoming gateway PINX: See ETS 300 172 [1].

information elements with invalid contents: See ETS 300 172 [1].

originating PINX: See ETS 300 172 [1].

outgoing call: See ETS 300 172 [1].

outgoing gateway PINX: See ETS 300 172 [1].

preceding PINX: See ETS 300 172 [1].

Private Integrated Network Exchange (PINX): See ETS 300 172 [1].

Private Integrated Services Network (PISN): See ETS 300 172 [1].

Protocol Implementation Conformance Statement (PICS): See ISO/IEC 9646-1 [4].

Protocol Implementation Extra Information For Testing (PIXIT): See ISO/IEC 9646-1 [4].

reassembly: The process whereby an implementation on receipt of the parts of a single message which has been segmented for transmission, reassembles these parts to make up the original message.

segmentation: The process by which a message is divided into parts when the message size exceeds the maximum size of the of the SCM information field.

Signalling Carriage Mechanism (SCM): See ETS 300 172 [1].

subsequent PINX: See ETS 300 172 [1].

super test purpose: A general test purpose from which one or more test purposes may be derived. These derived test purposes may be more detailed than the Super Test Purpose. This term is not defined in ISO/IEC 9646-1 [4] but corresponds to the "more specific test objectives" referred to in ISO/IEC 9646-2 [5] subclause 10.3.1.

terminating PINX: See ETS 300 172 [1].

transit PINX: See ETS 300 172 [1].

unexpected message: See ETS 300 172 [1].

unrecognised information element: See ETS 300 172 [1].

3.2 Abbreviations

For the purposes of this ETS, the following abbreviations apply:

ATS	Abstract Test Suite
IE	Information Element
IUT	Implementation Under Test
PICS	Protocol Implementation Conformance Statement
PIXIT	Protocol Implementation eXtra Information for Testing
PISN	Private Integrated Services Network
PSS1	Private Integrated Signalling System Number 1
PINX	Private Integrated Services Network eXchange
SCM	Signalling Carriage Mechanism
STP	Super Test Purpose
TP	Test purpose
TSS	Test Suite Structure

4 Test Suite Structure (TSS)

Following the rules described in ETS 300 406 [3], subclause 7.4.1.1, the test suite is structured as a tree with the following levels:

1st level: the name representing the base specification (ETS 300 172 [1]);

PSS1_BC

2nd level: Call Control for the major roles of the base specification (Originating, Terminating, Transit, Incoming Gateway, Outgoing Gateway) and Protocol Control which is common to all the behaviours;

- Protocol Control (PC);
- call control for OrIginating (OI);
- call control for TErminating (TE);
- call control for TRansit (TR);
- call control for InComing Gateway (IG);
- call control for Outgoing Gateway (OG).

3rd level: the nature of the test;

- Basic Interconnection test (BI);
- CApability test (CA);
- Valid behaviour tests (BV);
- InValid behaviour tests (IV);
- InOpportune behaviour tests (IO);
- TImers (TI).

4th level: the functional aspects tested;

- State Event transitions (SE);
- Parameter Variations (PV).

5th level: the phases of the base specification;

- Call Establishing (CE);
- Call Clearing (CC);
- Message Segmentation (MS) (this group may be empty for call control requirements);
- STATUS Procedures (ST) (this group may be empty for call control requirements);
- Layer Management (LM) (this group may be empty for call control requirements).

Figure 1 shows the PSS1 Layer 3 Test Suite Structure overview. Not all the branches have been expanded to the final details.

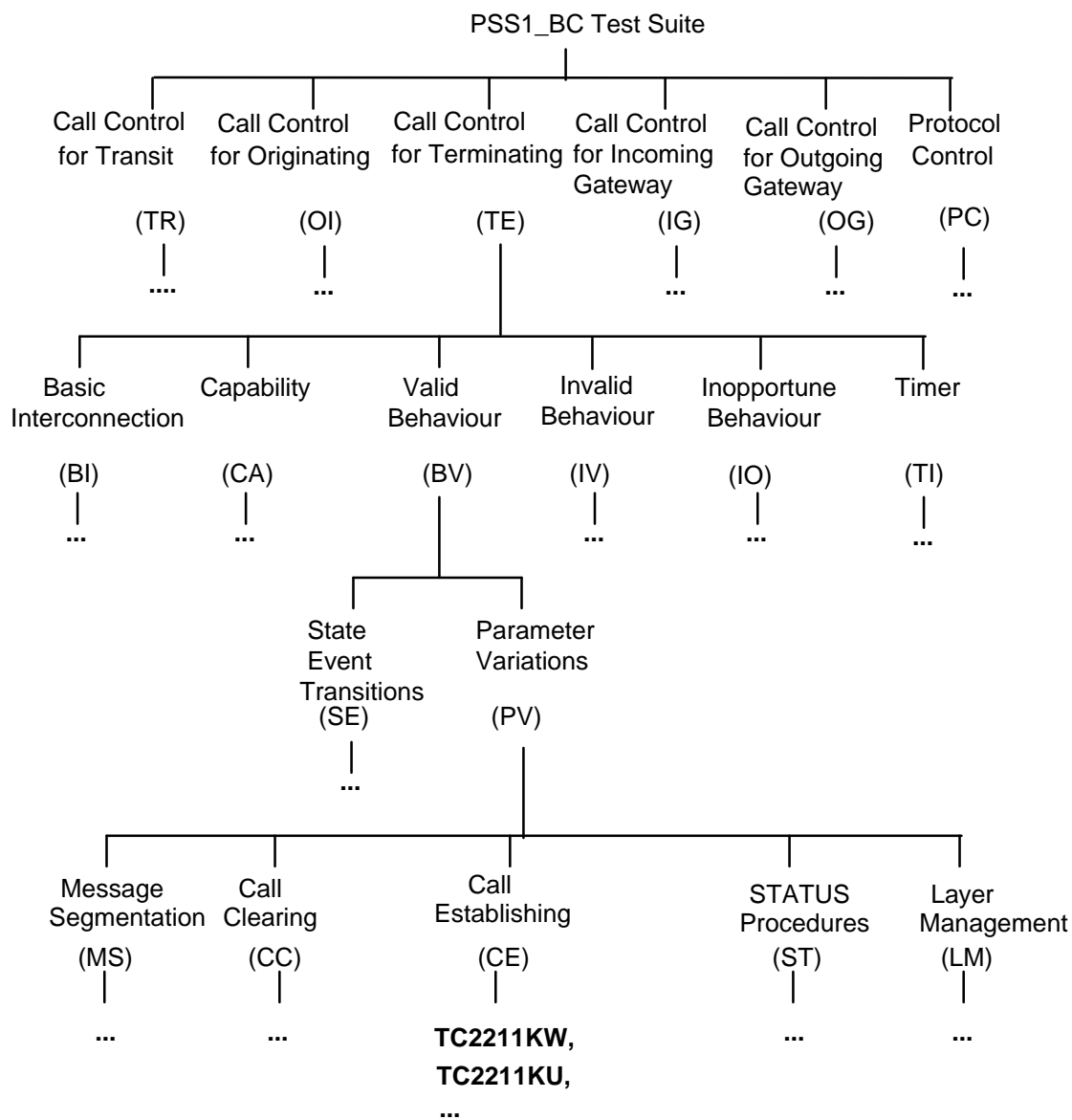

Figure 1: PSS1 Layer 3 TSS overview

Figure 2 shows the details of the PSS1 Layer 3 TSS. Not all the branches have been expanded to the final details.

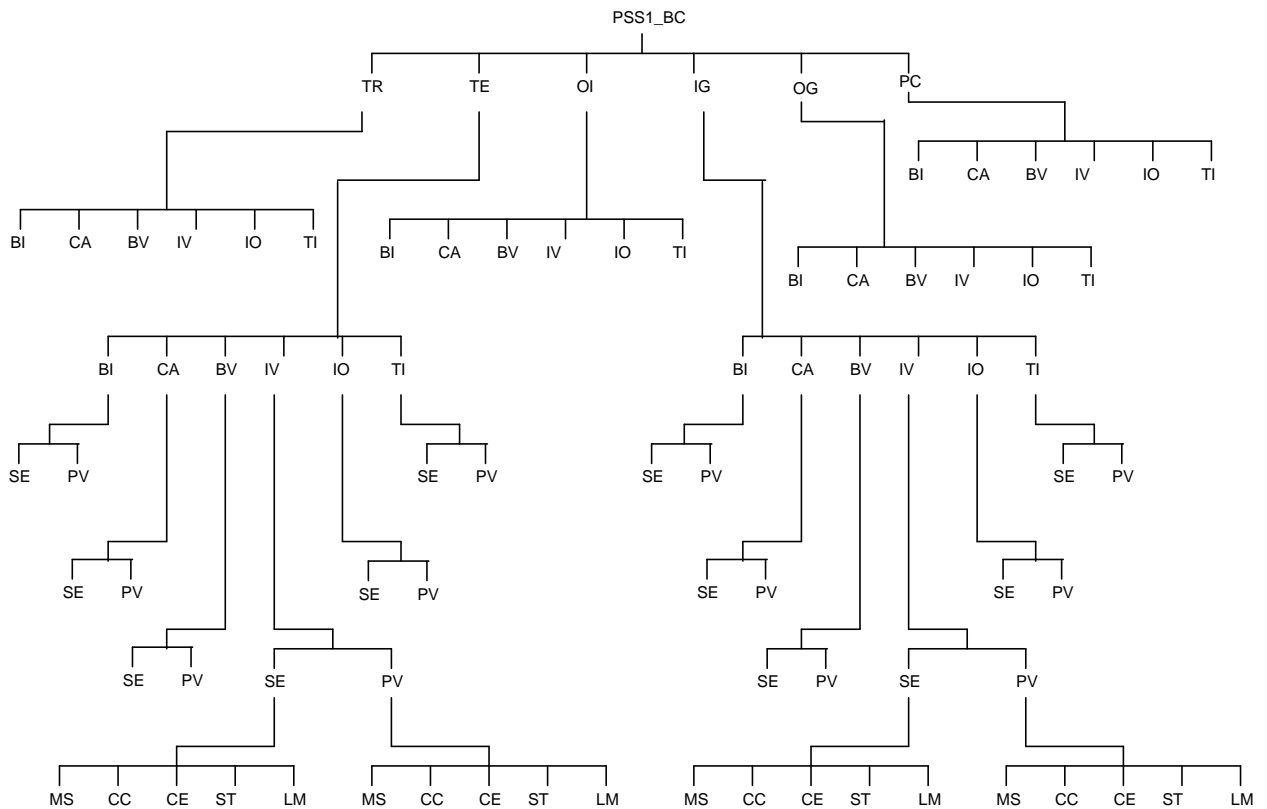

Figure 2: Detailed PSS1 Layer 3 TSS

5 Test Purposes (TP)

5.1 Introduction to Test Purposes

5.1.1 Test purposes production method

The TPs production method consisted of reviewing the standard and specifying everything that should be tested, i.e. all the characteristics that could be determined from the standard, which an implementation is required to conform to.

This first phase led to the production of "Super" Test Purposes (STPs), which are general TPs, reflecting more the functional aspects and the structure of the standard rather than the TSS itself (see clause 4).

The second phase consisted of deriving from each STP several "Final" TPs. These "Final" TPs are the individual TPs as identified in the Abstract Test Suite (ATS) (each of which will give rise to a Test Case). The criteria for deriving these "Final" TPs was to take into account the TSS, in order to ensure good coverage for testing. The objective was to derive "Final" TPs and distribute them over the complete TSS, taking into account all the testing aspects (valid behaviour, inopportune behaviour, timer, parameter variations, state event transition, etc.), while retaining all the requirements of the standard. In this way, one or more "Final" TPs may be derived from an STP.

Although an STP may generate a number of "Final" TPs, not all of them may be retained, as they may deal with a requirement which has already been covered by a previous "Final" TP. This ensures a more efficient testing with good coverage, avoiding repeatedly testing the same aspect of the standard, probably leading to the same verdict each time.

Some STPs are not decomposed into "Final" derived TPs, either because the requirement of this STP has already been covered by a previous "final" TP, or because it is determined to be untestable. In this case the STP is referenced as an "untestable" TP.

5.1.2 STP identifier

The STP identifier is described using a 5 digit alphanumeric code, this code is used in the following manner:

- characters 5-4 : 'SP';
- digit 3-2-1 : STP number.

PATTERN: SP<xyz> with <xyz> = 000 -> 999.

5.1.3 "Final" derived TP identifier

The TP identifier is described using an 8 digit alphanumeric code, this code is used in the following manner:

- characters 8-7 : 'TC';
- digit 6 : 2nd level of TSS;
- digit 5 : 3rd level of TSS;
- digit 4 : 4th level of TSS;
- digit 3 : 5th level of TSS;
- characters 2-1 : letters identifying the final TP.

PATTERN: TC<u><v><w><x><yz> with

- <u> =

0: protocol control
1: call control originating
2: call control terminating
3: call control transit
4: call control outgoing gateway
5: call control incoming gateway

- <v> =

0: basic interconnection test
1: capability test
2: valid behaviour tests
3: invalid behaviour test
4: inopportune behaviour tests
5: timer test

- <w> =

0: state events transitions
1: parameter variations

- <x> =

0: call establishing
1: call clearing
2: message segmentation
3: status procedures
4: layer management

- <yz> = AA-> ZZ

EXAMPLE 1: TC2211KW is the number of the **test purpose KW**, for a **terminating PINX**, to test the **valid behaviour** of the IUT, with **parameter variations**, during **call clearing**.

EXAMPLE 2: TC2211KU is the number of the **test purpose KU**, for a **terminating PINX**, to test the **valid behaviour** of the IUT, with **parameter variations**, during **call clearing**.

5.1.4 Standard options

In reviewing the standard to produce TPs, two situations have been identified regarding optional requirements.

The first case is where either the Implementation Under Test (IUT) performs an action which can be tested, or does nothing that can be tested. In this situation there is a TP for the case where the IUT does something testable and a Protocol Implementation eXtra Information for Testing (PIXIT) question should be used to select the associated test case.

The second case is where the IUT always performs a first action which has to be tested and optionally performs a second action which has also to be tested if it occurs. In this situation no PIXIT question is asked for this selection.

5.1.5 Message segmentation

Where a TP refers to a message sent by the IUT, this message may be segmented (unless otherwise stated) without affecting the TP.

5.2 Test purpose writing rules

Writing rules have been defined in order to have consistency between all the TPs. However, in some cases, it is not possible to use them without losing the real objective of the test. Consequently, a small number of TPs may deviate from these rules in a minor way.

5.2.1 Terminating, Originating, Incoming/Outgoing Gateway PINX

Table 1 gives the test purposes writing rules for non-transit PINX requirements.

Table 1: Test Purpose writing rules for non-transit PINX requirements

STRUCTURE	VALUES
Ensure that the IUT in call state	
<state>,	0,1, 2, 3, etc.
[<trigger if passive>	on receiving a XXX message, on expiry of Txxx, etc.
or <goal if active>]	in order to initiate call clearing, etc.
<action>	sends, saves, does, etc.
<conditions>	using en-bloc sending, using overlap sending, etc.
if the action is sending	
a <message type>	SETUP, CONNECT, etc.
message containing a	
a) <information element>	Channel Identification, Call Reference, etc.
IE with a	
b) <field name>	Channel Number, Call Reference Flag, etc.
encoded as	
<coding of the field>	16, 0, etc.
and back to a) or b)	
[and remains in the same state	
or and enters state]	
<state>.	0, 1, 2, etc
NOTE:	In this table normal text in the left hand column is included in the test purpose, text between < and > is replaced by a value (examples given in the right column). Text in bold is not included in the test purpose, [and] are used to delimit options and a) and b) are labels.

5.2.2 Transit PINX

Table 2 gives the test purposes writing rules for transit PINX requirements.

Table 2: Test Purpose writing rules for transit PINX requirements

STRUCTURE	VALUES
Ensure that the IUT in transit state	
<state>, in state	TCC_Overlap, TCC_CallActive, etc.
<state> for the call on interface X, and in state	0, 1, 2,3, etc.
<state> for the call on interface Y,	0, 1, 2, etc.
[<trigger if passive> or <goal if active>]	on receiving a XXX message on interface X (or Y), on expiry of Txxx on interface X (or Y), etc
a) <action>	sends, saves, does, etc.
<conditions>	using en-bloc sending, using overlap sending, etc.
if the action is sending	
b) a <message type> message containing a	SETUP, CONNECT, etc.
c) <information element> IE with a	Channel Identification, Call Reference, etc.
d) <field name> encoded as	Channel Number, Call Reference Flag, etc.
<coding of the field>	16, 0, in the XXX message received on interface X (or Y).
and back to c) or d) on interface	
<interface>	X,Y.
and back to a) or b)	
[and remains in the same state or and enters state]	
<state>	0, 1, 2, etc
for the call on interface X, [and remains in the same state or and enters state]	
<state>	0, 1, 2, etc.
for the call on interface Y.	
NOTE:	In this table normal text in the left hand column is included in the test purpose, text between < and > is replaced by a value (examples given in the right column). Text in bold is not included in the test purpose, [and] are used to delimit options and a) and b) are labels.

5.3 Test Purposes

NOTE 1: Only the derived "Final" TPs are used to produce test cases.

NOTE 2: Where a test purpose specifies that the IUT enters or remains in a specified Protocol Control or Layer Management state, this is verified as specified in subclause 5.3.12.

NOTE 3: Some TPs are not applicable to all implementations. In most cases this is clear from the TP (e.g. a TP which specifies an initial state, is only applicable to implementations which support that state). Where it is not clear, the applicability of an STP (and derived TPs), or all the TPs in a subclause, is indicated. The selection rule for the test case associated with each TP is indicated in the ATS. This takes into account the applicability of the TP and other factors (e.g. restrictions of the test method).

5.3.1 Protocol Control requirements for Call Establishment

The TPs in this subclause refer to ETS 300 172 [1], subclause 10.1.

5.3.1.1 Call Request

The TPs in this subclause refer to ETS 300 172 [1], subclause 10.1.1

SP001

- Ensure that the IUT in state 0, in order to initiate a call supporting 64 Kbits/s Unrestricted, sends a SETUP message containing a Bearer Capability IE with an Information Transfer Capability field encoded as Unrestricted and enters state 1 (reference ETS 300 172 [1], subclauses 10.1.1, 14.5.5, A.4.1.Z1).

This STP and its derived TP are only applicable to an IUT if support of 64 kbit/s Unrestricted Digital Information has been declared in the PICS.

PSS1_BC/PC/CA/PV/CE/ TC0110XD

- Ensure that the IUT in state 0, in order to initiate a call supporting 64 Kbits/s Unrestricted, sends a SETUP message containing a Bearer Capability IE with an Information Transfer Capability field encoded as Unrestricted (reference ETS 300 172 [1], subclauses 10.1.1, 14.5.5, A.4.1.Z1).

SP002

- Ensure that the IUT in state 0, in order to initiate a call supporting 64 Kbits/s Speech, sends a SETUP message containing a Bearer Capability IE with an Information Transfer Capability field encoded as Speech and enters state 1 (reference ETS 300 172 [1], subclauses 10.1.1, 14.5.5, A.4.1.Z2).

This STP and its derived TP are only applicable to an IUT if support of 64 kbit/s Speech has been declared in the PICS.

PSS1_BC/PC/CA/PV/CE/ TC0110XE

- Ensure that the IUT in state 0, in order to initiate a call supporting 64 Kbits/s Speech, sends a SETUP message containing a Bearer Capability IE with an Information Transfer Capability field encoded as Speech (reference ETS 300 172 [1], subclauses 10.1.1, 14.5.5, A.4.1.Z2).

SP003

- Ensure that the IUT in state 0, in order to initiate a call supporting 64 Kbits/s 3,1 kHz Audio, sends a SETUP message containing a Bearer Capability IE with an Information Transfer Capability field encoded as 3.1kHz Audio and enters state 1 (reference ETS 300 172 [1], subclauses 10.1.1, 14.5.5, A.4.1.Z3).

This STP and its derived TP are only applicable to an IUT if support of 64 kbit/s 3,1 kHz Audio has been declared in the PICS.

PSS1_BC/PC/CA/PV/CE/ TC0110XF

- Ensure that the IUT in state 0, in order to initiate a call supporting 64 Kbits/s 3.1kHz Audio, sends a SETUP message containing a Bearer Capability IE with an Information Transfer Capability field encoded as 3.1kHz Audio (reference ETS 300 172 [1], subclauses 10.1.1, 14.5.5, A.4.1.Z3).

SP306

- Ensure that the IUT in state 0, in order to initiate a call supporting 64 Kbits/s unrestricted digital information with tones and announcements, sends a SETUP message containing a Bearer Capability IE with an Information Transfer Capability field encoded as unrestricted digital information with tones and announcements and enters state 1 (reference ETS 300 172 [1], subclauses 10.1.1, 14.5.5, A.4.1.Z4).

This STP and its derived TP are only applicable to an IUT if support of 64 kbit/s Unrestricted Digital Information with Tones and Announcements has been declared in the PICS.

PSS1_BC/PC/CA/PV/CE/ TC0110YG

- Ensure that the IUT in state 0, in order to initiate a call supporting 64 Kbits/s unrestricted digital information with tones and announcements, sends a SETUP message containing a Bearer Capability IE with an Information Transfer Capability field encoded as unrestricted digital information with tones and announcements (reference ETS 300 172 [1], subclauses 10.1.1, 14.5.5, A.4.1.Z4).

SP007

- Ensure that the IUT in state 0, in order to initiate a call, sends a SETUP message, and enters state 1 (reference ETS 300 172 [1], subclause 10.1.1).

PSS1_BC/PC/CA/SE/CE/ TC0100AA

- Ensure that the IUT in state 0, in order to initiate a call, sends a SETUP message and enters state 1 (reference ETS 300 172 [1], subclause 10.1.1).

PSS1_BC/PC/CA/PV/CE/ TC0110AB

- Ensure that the IUT in state 0, in order to initiate a call, sends a SETUP message with the Bearer Capability IE (reference ETS 300 172 [1], subclause 10.1.1).

PSS1_BC/PC/CA/PV/CE/ TC0110AC

- Ensure that the IUT in state 0, in order to initiate a call, sends a SETUP message with the Channel Identification IE (reference ETS 300 172 [1], subclause 10.1.1).

PSS1_BC/PC/CA/PV/CE/ TC0110AD

- Ensure that the IUT in state 0, in order to initiate a call, sends a SETUP message with the Called Party Number IE (reference ETS 300 172 [1], subclause 10.1.1).

SP008

- Ensure that the IUT in state 1, at first expiry of timer T303, sends the same SETUP message as the one sent previously, (restarts timer T303) and remains in the same state (reference ETS 300 172 [1], subclause 10.1.1).

This STP and its derived TPs are only applicable to an IUT if it re-transmits SETUP.

PSS1_BC/PC/CA/SE/CE/ TC0100AE

- Ensure that the IUT in state 1, at first expiry of timer T303, sends a SETUP message and remains in the same state (reference ETS 300 172 [1], subclause 10.1.1).

PSS1_BC/PC/TI/PV/CE/ TC0510AF

- Ensure that the IUT in state 1, at first expiry of timer T303, sends the same SETUP message as the one sent previously (reference ETS 300 172 [1], subclause 10.1.1).

SP009

- Ensure that the IUT in state 1, at the second expiry of timer T303, sends a RELEASE COMPLETE message containing a Cause IE with a Cause Value encoded as 102, and enters state 0 (reference ETS 300 172 [1], subclause 10.1.1).

This STP and its derived TPs are only applicable to an IUT if it re-transmits SETUP.

PSS1_BC/PC/TI/SE/CE/ TC0500AG

- Ensure that the IUT in state 1, at the second expiry of timer T303, sends a RELEASE COMPLETE message, and enters state 0 (reference ETS 300 172 [1], subclause 10.1.1).

PSS1_BC/PC/TI/PV/CE/ TC0510AH

- Ensure that the IUT in state 1, at the second expiry of timer T303, sends a RELEASE COMPLETE message containing a Cause IE with a Cause Value encoded as 102 (reference ETS 300 172 [1], subclause 10.1.1).

SP010

- Ensure that the IUT in state 0, in order to initiate a call, sends a SETUP message containing a Channel Identification IE with a Channel Number indicating a free channel, and enters state 1 (reference ETS 300 172 [1], subclause 10.1.1).

PSS1_BC/PC/BV/PV/CE/ TC0210AI

- Ensure that the IUT in state 0, in order to initiate a call, sends a SETUP message containing a Channel Identification IE with a Channel Number indicating a free channel, and enters state 1 (reference ETS 300 172 [1], subclause 10.1.1).

SP011

- Ensure that the IUT in state 0, in order to initiate a call, sends a SETUP message containing a Call Reference IE with a Call Reference Flag encoded as 0 and a Call Reference Value coded in 2 octets, and enters state 1 (reference ETS 300 172 [1], subclauses 10.1.1 and 14.3).

PSS1_BC/PC/BI/PV/CE/ TC0010AJ

- Ensure that the IUT in state 0, in order to initiate a call, sends a SETUP message containing a Call Reference IE with a Call Reference Flag encoded as 0 (reference ETS 300 172 [1], subclauses 10.1.1 and 14.3).

PSS1_BC/PC/BI/PV/CE/ TC0010AK

- Ensure that the IUT in state 0, in order to initiate a call, sends a SETUP message containing a Call Reference IE with a Call Reference Value coded in 2 octets (reference ETS 300 172 [1], subclauses 10.1.1 and 14.3).

SP012

- Ensure that the IUT in state 0, in order to initiate a call, using en-bloc sending, sends a SETUP message containing a Called Party Number IE encoded as a complete Number as stated in the PIXIT, and enters state 1 (reference ETS 300 172 [1], subclause 10.1.1).

PSS1_BC/PC/CA/PV/CE/ TC0110AL

- Ensure that the IUT in state 0, in order to initiate a call, using en-bloc sending, sends a SETUP message containing a Called Party Number IE encoded as a complete Number as stated in the PIXIT (reference ETS 300 172 [1], subclause 10.1.1).

SP013

- Ensure that the IUT in state 0, in order to initiate a call, using en-bloc sending, sends a SETUP message containing a Sending Complete IE, and enters state 1 (reference ETS 300 172 [1], subclause 10.1.1).

This STP and its derived TP is only applicable in to IUTs which include Sending Complete in the SETUP message.

PSS1_BC/PC/CA/PV/CE/ TC0110AM

- Ensure that the IUT in state 0, in order to initiate a call, using en-bloc sending, sends a SETUP message containing a Sending Complete IE, and enters state 1 (reference ETS 300 172 [1], subclause 10.1.1).

SP014

- Ensure that the IUT in state 0, on receiving a SETUP message, enters state 6 (reference ETS 300 172 [1], subclause 10.1.1).

NOTE: This STP is referenced in 'Untestable TPs' section in the associated ATS specification document.

5.3.1.2 Information channel selection

The TPs in this subclause refer to ETS 300 172 [1], subclause 10.1.2

SP016

- Ensure that the IUT in state 1, on receiving an ALERTING or CONNECT message as the first response to the SETUP message, does not indicate a protocol error (reference ETS 300 172 [1], subclause 10.1.2).

PSS1_BC/PC/BV/PV/CE/ TC0210AZ

- Ensure that the IUT in state 1, on receiving an ALERTING message as the first response to the SETUP message, does not indicate a protocol error (reference ETS 300 172 [1], subclause 10.1.2).

PSS1_BC/PC/BV/PV/CE/ TC0210BA

- Ensure that the IUT in state 1, on receiving a CONNECT message as the first response to the SETUP message, sends a CONNECT ACK message (reference ETS 300 172 [1], subclause 10.1.2).

SP017

- Ensure that the IUT in state 1, on receiving a RELEASE COMPLETE message containing a Cause IE with a Cause Value encoded as 44, as the first response to the SETUP message containing a Channel Identification IE with the preferred/exclusive field encoded as exclusive, releases the Call Reference and enters state 0 (reference ETS 300 172 [1], subclauses 10.1.2 and 10.2.2).

PSS1_BC/PC/BV/SE/CE/ TC0200BB

- Ensure that the IUT in state 1, on receiving a RELEASE COMPLETE message containing a Cause IE with a Cause Value encoded as 44, as the first response to the SETUP message containing a Channel Identification IE with the preferred/exclusive field encoded as exclusive, enters state 0 (reference ETS 300 172 [1], subclauses 10.1.2 and 10.2.2).

SP018

- Ensure that the IUT in state 1, on receiving a RELEASE COMPLETE message containing a Cause IE with a Cause Value encoded as 34, as the first response to the SETUP message containing a Channel Identification IE with the preferred/exclusive field encoded as preferred, releases the Call Reference and enters state 0 (reference ETS 300 172 [1], subclauses 10.1.2 and 10.2.2).

PSS1_BC/PC/BV/SE/CE/ TC0200BC

- Ensure that the IUT in state 1, on receiving a RELEASE COMPLETE message containing a Cause IE with a Cause Value encoded as 34, as the first response to the SETUP message containing a Channel Identification IE with the preferred/exclusive field encoded as preferred, enters state 0 (reference ETS 300 172 [1], subclauses 10.1.2 and 10.2.2).

SP019

- Ensure that the IUT in state 1, on receiving a CALL PROCEEDING or SETUP ACKNOWLEDGE message containing a Channel Identification IE with a Channel Number encoded with an unacceptable channel number, as the first response to the SETUP message, sends a RELEASE message containing a Cause IE with a Cause Value encoded as 6, and enters state 19 (reference ETS 300 172 [1], subclauses 10.1.2 and 10.2.2) .

PSS1_BC/PC/BV/SE/CE/ TC0200BD

- Ensure that the IUT in state 1, on receiving a CALL PROCEEDING message containing a Channel Identification IE with a Channel Number encoded with a non-existent channel number, as the first response to the SETUP message, sends a RELEASE message containing a Cause IE with a Cause Value encoded as 6, and enters state 19 (reference ETS 300 172 [1], subclauses 10.1.2 and 10.2.2).

PSS1_BC/PC/CA/PV/CE/ TC0110BE

- Ensure that the IUT in state 1, on receiving a SETUP ACKNOWLEDGE message containing a Channel Identification IE with a Channel Number encoded with a channel number known to be busy, as the first response to the SETUP message, sends a RELEASE message containing a Cause IE with a Cause Value encoded as 6 (reference ETS 300 172 [1], subclauses 10.1.2 and 10.2.2).

SP020

- Ensure that the IUT in state 0, on receiving a SETUP message, containing a Channel Identification IE with a Channel Number encoded as **n**, known to be available, sends a CALL PROCEEDING or SETUP ACK message containing a Channel Identification IE with a Channel Number encoded as **n** and enters state 9 or 25 (reference ETS 300 172 [1], subclause 10.1.2).

PSS1_BC/PC/CA/PV/CE/ TC0110JD

- Ensure that the IUT in state 0, on receiving a SETUP message, containing a Channel Identification IE with a Channel Number encoded as **n**, known to be available, and a Sending Complete IE, sends a CALL PROCEEDING message containing a Channel Identification IE with a Channel Number encoded as **n** (reference ETS 300 172 [1], subclause 10.1.2).

SP021

- Ensure that the IUT in state 0, on receiving a SETUP message containing a Channel Identification IE with a Channel Number encoded as **n**, known to be busy, and a preferred/exclusive field encoded as preferred, having an alternative available Information channel whose number is **m**, sends a CALL PROCEEDING or SETUP ACK message containing a Channel Identification IE with a Channel Number encoded as **m**, and enters state 9 or 25 respectively (reference ETS 300 172 [1], subclause 10.1.2).

PSS1_BC/PC/BV/PV/CE/ TC0210JE

- Ensure that the IUT in state 0, on receiving a SETUP message containing a Channel Identification IE with a Channel Number encoded as **n**, known to be busy, and a preferred/exclusive field encoded as preferred, and a Sending Complete IE, having an alternative available Information channel whose number is **m**, sends a CALL PROCEEDING message containing a Channel Identification IE with a Channel Number encoded as **m** (reference ETS 300 172 [1], subclause 10.1.2).

SP022

- Ensure that the IUT in state 0, on receiving a SETUP message containing a Channel Identification IE with a Channel Number known to be busy and a preferred/exclusive field encoded as exclusive, sends a RELEASE COMPLETE message containing a Cause IE with a Cause Value encoded as 44, and enters state 0 (reference ETS 300 172 [1], subclause 10.1.2).

PSS1_BC/PC/BV/SE/CE/ TC0200JF

- Ensure that the IUT in state 0, on receiving a SETUP message containing a Channel Identification IE with a Channel Number known to be busy and a preferred/exclusive field encoded as exclusive, sends a RELEASE COMPLETE message containing a Cause IE with a Cause Value encoded as 44, and enters state 0 (reference ETS 300 172 [1], subclause 10.1.2).

SP023

- Ensure that the IUT in state 0, on receiving a SETUP message containing a Channel Identification IE with a Channel Number known to be busy and a preferred/exclusive field encoded as preferred, and having no alternative Information channel available, sends a RELEASE COMPLETE message containing a Cause IE with a Cause Value encoded as 34, and enters state 0 (reference ETS 300 172 [1], subclause 10.1.2).

PSS1_BC/PC/BV/SE/CE/ TC0200JG

- Ensure that the IUT in state 0, on receiving a SETUP message containing a Channel Identification IE with a Channel Number known to be busy and a preferred/exclusive field encoded as preferred, and having no alternative Information channel available, sends a RELEASE COMPLETE message containing a Cause IE with a Cause Value encoded as 34, and enters state 0 (reference ETS 300 172 [1], subclause 10.1.2).

5.3.1.3 Overlap Sending and Receiving

The TPs in this subclause refer to ETS 300 172 [1], subclause 10.1.3

SP024

- Ensure that the IUT in state 0, on receiving a SETUP message, not containing a Sending Complete IE and containing a Called Party Number IE with an incomplete number, sends a SETUP ACK message and enters state 25 (reference ETS 300 172 [1], subclause 10.1.3).

PSS1_BC/PC/CA/SE/CE/ TC0100JH

- Ensure that the IUT in state 0, on receiving a SETUP message, not containing a Sending Complete IE and containing a Called Party Number IE with an incomplete number, sends a SETUP ACK message and enters state 25 (reference ETS 300 172 [1], subclauses 10.1.3).

SP025

- Ensure that the IUT in state 25, on expiry of timer T302 and with called party number information which the IUT can determine to be incomplete sends a DISCONNECT message containing a Cause IE with a Cause Value encoded as 28, and enters state 11 (reference ETS 300 172 [1], subclauses 10.1.3 and 10.2.3).

PSS1_BC/PC/CA/SE/CE/ TC0100JI

- Ensure that the IUT in state 25, on expiry of timer T302 and with called party number information which the IUT can determine to be incomplete, sends a DISCONNECT message, and enters state 11 (reference ETS 300 172 [1], subclauses 10.1.3 and 10.2.3).

PSS1_BC/PC/TI/PV/CE/ TC0510JJ

- Ensure that the IUT in state 25, on expiry of timer T302 and with called party number information which the IUT can determine to be incomplete, sends a DISCONNECT message containing a Cause IE with a Cause Value encoded as 28 (reference ETS 300 172 [1], subclauses 10.1.3 and 10.2.3).

SP026

- Ensure that the IUT in state 25, on expiry of timer T302 and where the IUT cannot determine that the called number information is incomplete, sends a CALL PROCEEDING message, and enters state 9 (reference ETS 300 172 [1], subclause 10.1.3).

PSS1_BC/PC/CA/SE/CE/ TC0100JK

- Ensure that the IUT in state 25, on expiry of timer T302 and where the IUT cannot determine that the called number information is incomplete, sends a CALL PROCEEDING message, and enters state 9 (reference ETS 300 172 [1], subclause 10.1.3).

SP027

- Ensure that the IUT in state 25, on receiving an INFORMATION message, not containing a Sending Complete IE and where the IUT can determine that the called number information is complete, sends a CALL PROCEEDING message and enters state 9 (reference ETS 300 172 [1], subclause 10.1.3).

PSS1_BC/PC/BV/SE/CE/ TC0200JL

- Ensure that the IUT in state 25, on receiving an INFORMATION message, not containing a Sending Complete IE and where the IUT can determine that the called number information is complete, sends a CALL PROCEEDING message (reference ETS 300 172 [1], subclause 10.1.3).

SP028

- Ensure that the IUT in state 1, on receiving a SETUP ACK message, enters state2, and sends an INFORMATION message containing either a Sending Complete IE, or a Called Party Number IE, or both IEs (reference ETS 300 172 [1], subclauses 10.1.3 and 13.2.6).

This STP and its derived TPs are only applicable to an IUT if support of Overlap sending procedures has been declared in the PICS.

PSS1_BC/PC/CA/SE/CE/ TC0100BF

- Ensure that the IUT in state 1, on receiving a SETUP ACK message, enters state 2 (reference ETS 300 172 [1], subclause 10.1.3).

PSS1_BC/PC/BV/PV/CE/ TC0210BG

- Ensure that the IUT in state 1, on receiving a SETUP ACK message, sends an INFORMATION message containing either a Sending Complete IE, or a Called Party Number IE, or both IEs (reference ETS 300 172 [1], subclauses 10.1.3 and 13.2.6).

This TP is only applicable to an IUT if support of Overlap sending procedures has been declared in the PICS and the IUT can send INFORMATION messages.

SP029

- Ensure that the IUT in state 2, on expiry of T304, sends a DISCONNECT message containing a Cause IE with a Cause Value encoded as 102, and enters state 11 (reference ETS 300 172 [1], subclause 10.1.3).

This STP and its derived TPs are only applicable to an IUT if it can send SETUP messages not containing the Sending Complete information element.

PSS1_BC/PC/CA/SE/CE/ TC0100BH

- Ensure that the IUT in state 2, on expiry of T304, sends a DISCONNECT message, and enters state 11 (reference ETS 300 172 [1], subclause 10.1.3).

PSS1_BC/PC/TI/PV/CE/ TC0510BI

- Ensure that the IUT in state 2, on expiry of T304, sends a DISCONNECT message containing a Cause IE with a Cause Value encoded as 102 (reference ETS 300 172 [1], subclause 10.1.3).

5.3.1.4 Call Proceeding

The TPs in this subclause refer to ETS 300 172 [1], subclause 10.1.4.

SP030

- Ensure that the IUT in state 25, on receiving an INFORMATION message containing a Sending Complete IE and a Called Party Number IE with a valid number completing the called number information, sends a CALL PROCEEDING message, and enters state 9 (reference ETS 300 172 [1], subclauses 10.1.3 and 10.1.4.2).

PSS1_BC/PC/CA/SE/CE/ TC0100JM

- Ensure that the IUT in state 25, on receiving an INFORMATION message containing a Sending Complete IE and a Called Party Number IE with a valid number completing the called number information, sends a CALL PROCEEDING message (reference ETS 300 172 [1], subclauses 10.1.3 and 10.1.4.2).

SP032

- Ensure that the IUT in state 0, on receiving a SETUP message containing a Sending Complete IE, sends a CALL PROCEEDING message and enters state 9 (reference ETS 300 172 [1], subclause 10.1.4.1).

PSS1_BC/PC/CA/SE/CE/ TC0100JO

- Ensure that the IUT in state 0, on receiving a SETUP message containing a Sending Complete IE, sends a CALL PROCEEDING message and enters state 9 (reference ETS 300 172 [1], subclause 10.1.4.1).

SP033

- Ensure that the IUT in state 0, on receiving a SETUP message not containing a Sending Complete IE, where the IUT can determine that the called number information is complete, sends a CALL PROCEEDING message and enters state 9 (reference ETS 300 172 [1], subclause 10.1.4).

PSS1_BC/PC/BV/SE/CE/ TC0200JP

- Ensure that the IUT in state 0, on receiving a SETUP message not containing a Sending Complete IE, where the IUT can determine that the called number information is complete, sends a CALL PROCEEDING message (reference ETS 300 172 [1], subclause 10.1.4).

SP034

- Ensure that the IUT in state 0, on receiving a SETUP message, where the IUT can determine that for some reason the call cannot be supported, sends a RELEASE COMPLETE message and returns to state 0 (reference ETS 300 172 [1], subclause 10.1.4).

NOTE: This STP is referenced in the "Untestable TPs" section in the associated ATS specification document.

SP035

- Ensure that the IUT in state 25, where the IUT can determine that for some reason the call cannot be supported, sends a DISCONNECT message and enters state 11 (reference ETS 300 172 [1], subclause 10.1.4).

PSS1_BC/PC/BV/PV/CE/ TC0210JR

- Ensure that the IUT in state 25, on receiving an INFORMATION message containing a Called Party Number IE with an unassigned number, sends a DISCONNECT message and enters state 11 (reference ETS 300 172 [1], subclause 10.1.4).

SP036

- Ensure that the IUT in state 1, on receiving a CALL PROCEEDING message, enters state 3 (reference ETS 300 172 [1], subclause 10.1.4.2).

PSS1_BC/PC/CA/SE/CE/ TC0100BJ

- Ensure that the IUT in state 1, on receiving a CALL PROCEEDING message, enters state 3 (reference ETS 300 172 [1], subclause 10.1.4.2).

SP037

- Ensure that the IUT in state 2, on receiving a CALL PROCEEDING message, enters state 3 (reference ETS 300 172 [1], subclause 10.1.4.2).

PSS1_BC/PC/CA/SE/CE/ TC0100BK

- Ensure that the IUT in state 2, on receiving a CALL PROCEEDING message, enters state 3 (reference ETS 300 172 [1], subclause 10.1.4.2).

SP038

- Ensure that the IUT in state 3, on expiry of timer T310, sends a DISCONNECT message containing a Cause IE with a Cause Value encoded as 102, and enters state 11 (reference ETS 300 172 [1], subclause 10.1.4.2).

This STP and its derived TPs are only applicable to an IUT if support of T310 is declared in the PICS.

PSS1_BC/PC/CA/SE/CE/ TC0100BL

- Ensure that the IUT in state 3, on expiry of timer T310, sends a DISCONNECT message, and enters state 11 (reference ETS 300 172 [1], subclause 10.1.4.2).

PSS1_BC/PC/TI/PV/CE/ TC0510BM

- Ensure that the IUT in state 3, on expiry of timer T310, sends a DISCONNECT message containing a Cause IE with a Cause Value encoded as 102 (reference ETS 300 172 [1], subclause 10.1.4.2).

5.3.1.5 Call Confirmation indication

The TPs in this subclause refer to ETS 300 172 [1], subclause 10.1.5

SP039

- Ensure that the IUT in state 2 or 3, on receiving an ALERTING message, enters state 4 (reference ETS 300 172 [1], subclause 10.1.5).

PSS1_BC/PC/BV/SE/CE/ TC0200XC

- Ensure that the IUT in state 2, on receiving an ALERTING message, enters state 4 (reference ETS 300 172 [1], subclause 10.1.5).

PSS1_BC/PC/CA/SE/CE/ TC0100BN

- Ensure that the IUT in state 3, on receiving an ALERTING message, enters state 4 (reference ETS 300 172 [1], subclause 10.1.5).

SP040

- Ensure that the IUT in state 4, on expiry of timer T301, sends a DISCONNECT message containing a Cause IE with a Cause Value encoded as 19, and enters state 11 (reference ETS 300 172 [1], subclause 10.1.5).

This STP and its derived TPs are only applicable to an IUT if support of T301 is declared in the PICS.

PSS1_BC/PC/CA/SE/CE/ TC0100BO

- Ensure that the IUT in state 4, on expiry of timer T301, sends a DISCONNECT message, and enters state 11 (reference ETS 300 172 [1], subclause 10.1.5).

PSS1_BC/PC/PI/PV/CE/ TC0510BP

- Ensure that the IUT in state 4, on expiry of timer T301, sends a DISCONNECT message containing a Cause IE with a Cause Value encoded as 19 (reference ETS 300 172 [1], subclause 10.1.5).

SP041

- Ensure that the IUT in state 9 in order to indicate that the called user is being alerted, sends an ALERTING message and enters state 7 (reference ETS 300 172 [1], subclauses 10.1.4.2 and 10.1.5).

PSS1_BC/PC/CA/SE/CE/ TC0100JS

- Ensure that the IUT in state 9 in order to indicate that the called user is being alerted, sends an ALERTING message and enters state 7 (reference ETS 300 172 [1], subclauses 10.1.4.2 and 10.1.5).

5.3.1.6 Call Connected

The TPs in this subclause refer to ETS 300 172 [1], subclause 10.1.6

SP042

- Ensure that the IUT in state 2, 3, or 4, on receiving a CONNECT message sends a CONNECT ACK message, and enters state 10 (reference ETS 300 172 [1], subclause 10.1.6).

PSS1_BC/PC/CA/SE/CE/ TC0100XA

- Ensure that the IUT in state 2, on receiving a CONNECT message, sends a CONNECT ACKNOWLEDGE message and enters state 10 (reference ETS 300 172 [1], subclause 10.1.6).

PSS1_BC/PC/BV/SE/CE/ TC0200XB

- Ensure that the IUT in state 3, on receiving a CONNECT message, sends a CONNECT ACKNOWLEDGE message and enters state 10 (reference ETS 300 172 [1], subclause 10.1.6).

PSS1_BC/PC/BV/SE/CE/ TC0200BQ

- Ensure that the IUT in state 4, on receiving a CONNECT message, sends a CONNECT ACKNOWLEDGE message and enters state 10 (reference ETS 300 172 [1], subclause 10.1.6).

SP043

- Ensure that the IUT in state 9 or 7, in order to indicate that the call has been answered, sends a CONNECT message and enters state 8 or 10 (reference ETS 300 172 [1], subclauses 10.1.4.2 and 10.1.6).

PSS1_BC/PC/BI/SE/CE/ TC0000JU

- Ensure that the IUT in state 9, in order to indicate that the call has been answered, sends a CONNECT message and enters state 8 or 10 (reference ETS 300 172 [1], subclauses 10.1.4.2 and 10.1.6).

PSS1_BC/PC/BI/SE/CE/ TC0000JV

- Ensure that the IUT in state 7, in order to indicate that the call has been answered, sends a CONNECT message and enters state 8 or 10 (reference ETS 300 172 [1], subclauses 10.1.4.2 and 10.1.6).

SP044

- Ensure that the IUT in state 8, on receiving a CONNECT ACK message, and enters state 10 (reference ETS 300 172 [1], subclauses 10.1.4.2 and 10.1.6).

PSS1_BC/PC/BV/SE/CE/ TC0200JW

- Ensure that the IUT in state 8, on receiving a CONNECT ACK message, enters state 10 (reference ETS 300 172 [1], subclauses 10.1.4.2 and 10.1.6).

SP045

- Ensure that the IUT in state 10, for an incoming call, on receiving a CONNECT ACK message, remains in the same state (reference ETS 300 172 [1], subclauses 10.1.4.2 and 10.1.6).

PSS1_BC/PC/BV/SE/CE/ TC0200JX

- Ensure that the IUT in state 10 for an incoming call, on receiving a CONNECT ACK message, remains in the same state (reference ETS 300 172 [1], subclauses 10.1.4.2 and 10.1.6).

SP046

- Ensure that the IUT in state 7, 8, 9 or 10, on receiving an INFORMATION message, discards the message and remains in the same state (reference ETS 300 172 [1], subclauses 10.1.4.2 and 10.1.6).

PSS1_BC/PC/BV/SE/CE/ TC0200JY

- Ensure that the IUT in state 7, on receiving an INFORMATION message, discards the message and remains in the same state (reference ETS 300 172 [1], subclauses 10.1.4.2 and 10.1.6).

PSS1_BC/PC/BV/SE/CE/ TC0200JZ

- Ensure that the IUT in state 8, on receiving an INFORMATION message, discards the message and remains in the same state (reference ETS 300 172 [1], subclauses 10.1.4.2 and 10.1.6).

PSS1_BC/PC/BV/SE/CE/ TC0200KA

- Ensure that the IUT in state 9, on receiving an INFORMATION message, discards the message and remains in the same state (reference ETS 300 172 [1], subclauses 10.1.4.2 and 10.1.6).

PSS1_BC/PC/BV/SE/CE/ TC0200KB

- Ensure that the IUT in state 10 for an incoming call, on receiving an INFORMATION message, discards the message and remains in the same state (reference ETS 300 172 [1], subclauses 10.1.4.2 and 10.1.6).

SP047

- Ensure that the IUT in state 8, on expiry of timer T313, sends a DISCONNECT message containing a Cause IE with a Cause Value encoded as 102, and enters state 11 (reference ETS 300 172 [1], subclauses 10.1.6 and 10.2.3).

This STP and its derived TPs are only applicable to an IUT if support of T313 is declared in the PICS.

PSS1_BC/PC/CA/SE/CE/ TC0100KC

- Ensure that the IUT in state 8, on expiry of timer T313, sends a DISCONNECT message, and enters state 11 (reference ETS 300 172 [1], subclauses 10.1.6 and 10.2.3).

PSS1_BC/PC/TI/PV/CE/ TC0510KD

- Ensure that the IUT in state 8, on expiry of timer T313, sends a DISCONNECT message containing a Cause IE with a Cause Value encoded as 102 (reference ETS 300 172 [1], subclauses 10.1.6 and 10.2.3).

5.3.1.7 Use of the PROGRESS message

The TPs in this subclause refer to ETS 300 172 [1], subclause 10.1.7.

SP048

- Ensure that the IUT in state 2, 3, or 4, on receiving a PROGRESS message, remains in the same state (reference ETS 300 172 [1], subclause 10.1.7.1).

NOTE: No final test purpose has been derived because this super TP is covered by TC0110BS, TC0210BT and TC0210BU derived from SP049

SP049

- Ensure that the IUT in state 2, 3, or 4, on receiving a PROGRESS message containing a Progress Indicator IE with a Progress Description value encoded as 1, 2 or 8, remains in the same state (reference ETS 300 172 [1], subclause 10.1.7.1).

PSS1_BC/PC/CA/PV/CE/ TC0110BS

- Ensure that the IUT in state 2, on receiving a PROGRESS message containing a Progress Indicator IE with a Progress Description value encoded as 1, remains in the same state (reference ETS 300 172 [1], subclause 10.1.7.1).

PSS1_BC/PC/BV/PV/CE/ TC0210BT

- Ensure that the IUT in state 3, on receiving a PROGRESS message containing a Progress Indicator IE with a Progress Description value encoded as 2, remains in the same state (reference ETS 300 172 [1], subclause 10.1.7.1).

PSS1_BC/PC/BV/PV/CE/ TC0210BU

- Ensure that the IUT in state 4, on receiving a PROGRESS message containing a Progress Indicator IE with a Progress Description value encoded as 8, remains in the same state (reference ETS 300 172 [1], subclause 10.1.7.1).

SP050

- Ensure that the IUT in state 7,9,10 or 25 in order to indicate progress information, sends an ALERTING or CONNECT or PROGRESS message containing a Progress Indicator IE and remains in the same state (reference ETS 300 172 [1], subclause 10.1.7).

PSS1_BC/PC/BV/PV/CE/ TC0210KM

- Ensure that the IUT in state 7, in order to indicate progress information, sends a PROGRESS message containing a Progress Indicator IE (reference ETS 300 172 [1], subclause 10.1.7).

PSS1_BC/PC/BV/PV/CE/ TC0210KN

- Ensure that the IUT in state 7, in order to indicate progress information, sends a CONNECT message containing a Progress Indicator IE (reference ETS 300 172 [1], subclause 10.1.7).

PSS1_BC/PC/BV/PV/CE/ TC0210KP

- Ensure that the IUT in state 9, in order to indicate progress information, sends a PROGRESS message containing a Progress Indicator IE (reference ETS 300 172 [1], subclause 10.1.7).

PSS1_BC/PC/BV/PV/CE/ TC0210KQ

- Ensure that the IUT in state 9, in order to indicate progress information, sends an ALERTING message containing a Progress Indicator IE (reference ETS 300 172 [1], subclause 10.1.7).

PSS1_BC/PC/BV/PV/CE/ TC0210KR

- Ensure that the IUT in state 9, in order to indicate progress information, sends a CONNECT message containing a Progress Indicator IE (reference ETS 300 172 [1], subclause 10.1.7).

PSS1_BC/PC/BV/PV/CE/ TC0210KS

- Ensure that the IUT in state 10, in order to indicate progress information, sends a PROGRESS message containing a Progress Indicator IE (reference ETS 300 172 [1], subclause 10.1.7).

PSS1_BC/PC/BV/PV/CE/ TC0210KT

- Ensure that the IUT in state 25, in order to indicate progress information, sends a PROGRESS message containing a Progress Indicator IE (reference ETS 300 172 [1], subclause 10.1.7).

5.3.1.8 Call collisions

The TPs in this subclause refer to ETS 300 172 [1], subclause 10.3.

SP051

- Ensure that the IUT in state 1, configured as A, after having sent a SETUP message containing a Channel Identification IE with a Channel Number encoded as **n** and a preferred/exclusive field encoded as exclusive, on receiving a SETUP message containing a Channel Identification IE with a Channel Number encoded as **n** and a preferred/exclusive field encoded as exclusive, sends a RELEASE COMPLETE message containing a Cause IE with a Cause Value encoded as 44, and enters state 0 for the incoming call (reference ETS 300 172 [1], subclause 10.3).

PSS1_BC/PC/CA/SE/CE/ TC0100BV

- Ensure that the IUT in state 1, configured as A, after having sent a SETUP message containing a Channel Identification IE with a Channel Number encoded as **n** and a preferred/exclusive field encoded as exclusive, on receiving a SETUP message containing a Channel Identification IE with a Channel Number encoded as **n** and a preferred/exclusive field encoded as exclusive, sends a RELEASE COMPLETE message, and enters state 0 for the incoming call (reference ETS 300 172 [1], subclause 10.3).

PSS1_BC/PC/BV/PV/CE/ TC0210BW

- Ensure that the IUT in state 1, configured as A, after having sent a SETUP message containing a Channel Identification IE with a Channel Number encoded as **n** and a preferred/exclusive field encoded as exclusive, on receiving a SETUP message containing a Channel Identification IE with a Channel Number encoded as **n** and a preferred/exclusive field encoded as exclusive, sends a RELEASE COMPLETE message containing a Cause IE with a Cause Value encoded as 44 (reference ETS 300 172 [1], subclause 10.3).

SP052

- Ensure that the IUT in state 1, configured as B, after having sent a SETUP message containing a Channel Identification IE with a Channel Number encoded as **n** and a preferred/exclusive field encoded as exclusive, on receiving a SETUP message containing a Channel Identification IE with a Channel Number **n** and a preferred/exclusive field encoded as exclusive, sends a CALL PROCEEDING or SETUP ACK message containing a Channel Identification IE with a Channel Number encoded as **n**, and enters state 9 or 25 respectively for the incoming call (reference ETS 300 172 [1], subclause 10.3).

PSS1_BC/PC/BV/SE/CE/ TC0200BX

- Ensure that the IUT in state 1, configured as B, after having sent a SETUP message containing a Channel Identification IE with a Channel Number encoded as **n** and a preferred/exclusive field encoded as exclusive, on receiving a SETUP message containing a Channel Identification IE with a Channel Number **n** and a preferred/exclusive field encoded as exclusive, sends a CALL PROCEEDING or SETUP ACK message, and enters state 9 or 25 respectively for the incoming call (reference ETS 300 172 [1], subclause 10.3).

PSS1_BC/PC/BV/PV/CE/ TC0210BY

- Ensure that the IUT in state 1, configured as B, after having sent a SETUP message containing a Channel Identification IE with a Channel Number encoded as **n** and a preferred/exclusive field encoded as exclusive, on receiving a SETUP message containing a Channel Identification IE with a Channel Number **n** and a preferred/exclusive field encoded as exclusive, sends a CALL PROCEEDING or SETUP ACK message containing a Channel Identification IE with a Channel Number encoded as **n** (reference ETS 300 172 [1], subclause 10.3).

SP053

- Ensure that the IUT in state 1, configured as A, after having sent a SETUP message containing a Channel Identification IE with a Channel Number encoded as **n** and a preferred/exclusive field encoded as preferred, on receiving a SETUP message containing a Channel Identification IE with a Channel Number encoded as **n** and a preferred/exclusive field encoded as preferred, and having no alternative Information channel available, sends a RELEASE COMPLETE message containing a Cause IE with a Cause Value encoded as 34, and enters state 0 for the incoming call (reference ETS 300 172 [1], subclause 10.3).

PSS1_BC/PC/BV/PV/CE/ TC0210BZ

- Ensure that the IUT in state 1, configured as A, after having sent a SETUP message containing a Channel Identification IE with a Channel Number encoded as **n** and a preferred/exclusive field encoded as preferred, on receiving a SETUP message containing a Channel Identification IE with a Channel Number encoded as **n** and a preferred/exclusive field encoded as preferred, and having no alternative Information channel available, sends a RELEASE COMPLETE message containing a Cause IE with a Cause Value encoded as 34 (reference ETS 300 172 [1], subclause 10.3).

SP054

- Ensure that the IUT in state 1, configured as A, after having sent a SETUP message containing a Channel Identification IE with a Channel Number encoded as **n** and a preferred/exclusive field encoded as preferred, on receiving a SETUP message containing a Channel Identification IE with a Channel Number encoded as **n** and a preferred/exclusive field encoded as preferred, and having an alternative Information channel available, sends a CALL PROCEEDING or SETUP ACK message containing a Channel Identification IE with a Channel Number encoded with a different channel number from **n**, and enters state 9 or 25 respectively for the incoming call (reference ETS 300 172 [1], subclause 10.3).

PSS1_BC/PC/BV/PV/CE/ TC0210CA

- Ensure that the IUT in state 1, configured as A, after having sent a SETUP message containing a Channel Identification IE with a Channel Number encoded as **n** and a preferred/exclusive field encoded as preferred, on receiving a SETUP message containing a Channel Identification IE with a Channel Number encoded as **n** and a preferred/exclusive field encoded as preferred, and having an alternative Information channel available, sends a CALL PROCEEDING or SETUP ACK message containing a Channel Identification IE with a Channel Number encoded with a different channel number from **n** (reference ETS 300 172 [1], subclause 10.3).

SP055

- Ensure that the IUT in state 1, configured as B, after having sent a SETUP message containing a Channel Identification IE with a Channel Number encoded as **n** and a preferred/exclusive field encoded as preferred, on receiving a SETUP message containing a Channel Identification IE with a Channel Number encoded as **n** and a preferred/exclusive field encoded as preferred, sends a CALL PROCEEDING or SETUP ACK message containing a Channel Identification IE with a Channel Number encoded as **n**, and enters state 9 or 25 respectively for the incoming call (reference ETS 300 172 [1], subclause 10.3).

PSS1_BC/PC/CA/PV/CE/ TC0110CB

- Ensure that the IUT in state 1, configured as B, after having sent a SETUP message containing a Channel Identification IE with a Channel Number encoded as **n** and a preferred/exclusive field encoded as preferred, on receiving a SETUP message containing a Channel Identification IE with a Channel Number encoded as **n** and a preferred/exclusive field encoded as preferred, sends a CALL PROCEEDING or SETUP ACK message containing a Channel Identification IE with a Channel Number encoded as **n** (reference ETS 300 172 [1], subclause 10.3).

SP056

- Ensure that the IUT in state 1, after having sent a SETUP message containing a Channel Identification IE with a Channel Number encoded as **n** and a preferred/exclusive field encoded as exclusive, on receiving a SETUP message containing a Channel Identification IE with a Channel Number encoded as **n** and a preferred/exclusive field encoded as preferred, and having no alternative Information channel available, sends a RELEASE COMPLETE message containing a Cause IE with a Cause Value encoded as 34, and enters state 0 for the incoming call (reference ETS 300 172 [1], subclause 10.3).

PSS1_BC/PC/BV/PV/CE/ TC0210CC

- Ensure that the IUT in state 1, after having sent a SETUP message containing a Channel Identification IE with a Channel Number encoded as **n** and a preferred/exclusive field encoded as exclusive, on receiving a SETUP message containing a Channel Identification IE with a Channel Number encoded as **n** and a preferred/exclusive field encoded as preferred, and having no alternative Information channel available, sends a RELEASE COMPLETE message containing a Cause IE with a Cause Value encoded as 34 (reference ETS 300 172 [1], subclause 10.3).

SP057

- Ensure that the IUT in state 1, after having sent a SETUP message containing a Channel Identification IE with a Channel Number encoded as **n** and a preferred/exclusive field encoded as exclusive, on receiving a SETUP message containing a Channel Identification IE with a Channel Number encoded as **n** and a preferred/exclusive field encoded as preferred, and having an alternative Information channel available, sends a CALL PROCEEDING or SETUP ACK message containing a Channel Identification IE with a Channel Number encoded with a channel number different from **n**, and enters state 9 or 25 respectively for the incoming call (reference ETS 300 172 [1], subclause 10.3).

PSS1_BC/PC/BV/PV/CE/ TC0210CD

- Ensure that the IUT in state 1, after having sent a SETUP message containing a Channel Identification IE with a Channel Number encoded as **n** and a preferred/exclusive field encoded as exclusive, on receiving a SETUP message containing a Channel Identification IE with a Channel Number encoded as **n** and a preferred/exclusive field encoded as preferred, and having an alternative Information channel available, sends a CALL PROCEEDING or SETUP ACK message containing a Channel Identification IE with a Channel Number encoded with a channel number different from **n** (reference ETS 300 172 [1], subclause 10.3).

SP058

- Ensure that the IUT in state 1, after having sent a SETUP message containing a Channel Identification IE with a Channel Number encoded as **n** and a preferred/exclusive field encoded as preferred, on receiving a SETUP message containing a Channel Identification IE with a Channel Number encoded as **n** and a preferred/exclusive field encoded as exclusive, sends a CALL PROCEEDING or SETUP ACK message containing a Channel Identification IE with a Channel Number encoded as **n**, and enters state 9 or 25 respectively for the incoming call (reference ETS 300 172 [1], subclause 10.3).

PSS1_BC/PC/BV/PV/CE/ TC0210CE

- Ensure that the IUT in state 1, after having sent a SETUP message containing a Channel Identification IE with a Channel Number encoded as **n** and a preferred/exclusive field encoded as preferred, on receiving a SETUP message containing a Channel Identification IE with a Channel Number encoded as **n** and a preferred/exclusive field encoded as exclusive, sends a CALL PROCEEDING or SETUP ACK message containing a Channel Identification IE with a Channel Number encoded as **n** (reference ETS 300 172 [1], subclause 10.3).

5.3.2 Protocol Control requirements for Call Clearing

The TPs in this subclause refer to ETS 300 172 [1], subclause 10.2

5.3.2.1 Clearing

The TPs in this subclause refer to ETS 300 172 [1], subclause 10.2.3

SP059

- Ensure that the IUT in state 2,3,4,7,8,9,10 or 25 in order to initiate call clearing, sends a DISCONNECT message, (disconnects the Information channel, starts T305), and enters state 11 (reference ETS 300 172 [1], subclause 10.2.3).

PSS1_BC/PC/BV/SE/CC/ TC0201CI

- Ensure that the IUT in state 10, in order to initiate call clearing, sends a DISCONNECT message and enters state 11 (reference ETS 300 172 [1], subclause 10.2.3).

PSS1_BC/PC/BV/SE/CC/ TC0201XL

- Ensure that the IUT in state 2, in order to initiate call clearing, sends a DISCONNECT message and enters state 11 (reference ETS 300 172 [1], subclause 10.2.3).

PSS1_BC/PC/BV/SE/CC/ TC0201XM

- Ensure that the IUT in state 3, in order to initiate call clearing, sends a DISCONNECT message and enters state 11 (reference ETS 300 172 [1], subclause 10.2.3).

PSS1_BC/PC/BV/SE/CC/ TC0201XN

- Ensure that the IUT in state 4, in order to initiate call clearing, sends a DISCONNECT message and enters state 11 (reference ETS 300 172 [1], subclause 10.2.3).

PSS1_BC/PC/BV/PV/CC/ TC0211CF

- Ensure that the IUT in state 7, in order to initiate call clearing, sends a DISCONNECT message and enters state 11 (reference ETS 300 172 [1], subclause 10.2.3).

PSS1_BC/PC/BV/SE/CC/ TC0201CG

- Ensure that the IUT in state 8, in order to initiate call clearing, sends a DISCONNECT message and enters state 11 (reference ETS 300 172 [1], subclause 10.2.3).

PSS1_BC/PC/BV/PV/CC/ TC0211CH

- Ensure that the IUT in state 9, in order to initiate call clearing, sends a DISCONNECT message and enters state 11 (reference ETS 300 172 [1], subclause 10.2.3).

PSS1_BC/PC/BV/PV/CC/ TC0211CJ

- Ensure that the IUT in state 25, in order to initiate call clearing, sends a DISCONNECT message and enters state 11 (reference ETS 300 172 [1], subclause 10.2.3).

SP060

- Ensure that the IUT in state 2,3,4,7,8,9,10 or 25, on receiving a DISCONNECT message, (disconnects the Information channel, starts T308), sends a RELEASE message and enters state 19 (reference ETS 300 172 [1], subclause 10.2.3).

PSS1_BC/PC/BV/PV/CC/ TC0211CK

- Ensure that the IUT in state 2, on receiving a DISCONNECT message, sends a RELEASE message and enters state 19 (reference ETS 300 172 [1], subclause 10.2.3).

PSS1_BC/PC/BV/SE/CC/ TC0201CL

- Ensure that the IUT in state 3, on receiving a DISCONNECT message, sends a RELEASE message and enters state 19 (reference ETS 300 172 [1], subclause 10.2.3).

PSS1_BC/PC/BV/PV/CC/ TC0211CM

- Ensure that the IUT in state 4, on receiving a DISCONNECT message, sends a RELEASE message and enters state 19 (reference ETS 300 172 [1], subclause 10.2.3).

PSS1_BC/PC/BV/SE/CC/ TC0201CN

- Ensure that the IUT in state 7, on receiving a DISCONNECT message, sends a RELEASE message and enters state 19 (reference ETS 300 172 [1], subclause 10.2.3).

PSS1_BC/PC/BV/PV/CC/ TC0211CO

- Ensure that the IUT in state 8, on receiving a DISCONNECT message, sends a RELEASE message and enters state 19 (reference ETS 300 172 [1], subclause 10.2.3).

PSS1_BC/PC/BV/SE/CC/ TC0201CP

- Ensure that the IUT in state 9, on receiving a DISCONNECT message, sends a RELEASE message and enters state 19 (reference ETS 300 172 [1], subclause 10.2.3).

PSS1_BC/PC/BV/SE/CC/ TC0201CR

- Ensure that the IUT in state 25, on receiving a DISCONNECT message, sends a RELEASE message and enters state 19 (reference ETS 300 172 [1], subclause 10.2.3).

PSS1_BC/PC/CA/PV/CC/ TC0111CQ

- Ensure that the IUT in state 10, on receiving a DISCONNECT message, sends a RELEASE message and enters state 19 (reference ETS 300 172 [1], subclause 10.2.3).

SP061

- Ensure that the IUT in state 11, on receiving a RELEASE message, (releases the Information channel and the call reference, stops T305), sends a RELEASE COMPLETE message and enters state 0 (reference ETS 300 172 [1], subclause 10.2.3).

PSS1_BC/PC/CA/SE/CC/ TC0101CS

- Ensure that the IUT in state 11, on receiving a RELEASE message, sends a RELEASE COMPLETE message and enters state 0 (reference ETS 300 172 [1], subclause 10.2.3).

SP062

- Ensure that the IUT in state 19, on receiving a RELEASE COMPLETE message, (releases the Information channel and the call reference, stops T308), enters state 0 (reference ETS 300 172 [1], subclause 10.2.3).

PSS1_BC/PC/BV/SE/CC/ TC0201CU

- Ensure that the IUT in state 19, on receiving a RELEASE COMPLETE message, enters state 0 (reference ETS 300 172 [1], subclause 10.2.3).

SP063

- Ensure that the IUT in state 11, on expiry of T305, sends a RELEASE message containing a Cause IE with a Cause Value encoded as in the DISCONNECT message sent previously and enters state 19 (reference ETS 300 172 [1], subclause 10.2.3).

PSS1_BC/PC/PI/PV/CC/ TC0511CV

- Ensure that the IUT in state 11, on expiry of T305, sends a RELEASE message containing a Cause IE with a Cause Value encoded as in the DISCONNECT message sent previously (reference ETS 300 172 [1], subclause 10.2.3).

PSS1_BC/PC/CA/SE/CC/ TC0101CW

- Ensure that the IUT in state 11, on expiry of T305, sends a RELEASE message and enters state 19 (reference ETS 300 172 [1], subclause 10.2.3).

SP064

- Ensure that the IUT in state 19, on first expiry of T308, sends another RELEASE message, and remains in the same state (reference ETS 300 172 [1], subclause 10.2.3).

PSS1_BC/PC/CA/PV/CC/ TC0111CX

- Ensure that the IUT in state 19, on first expiry of T308, sends another RELEASE message (reference ETS 300 172 [1], subclause 10.2.3).

PSS1_BC/PC/PI/SE/CC/ TC0501CY

- Ensure that the IUT in state 19, on first expiry of T308, sends another RELEASE message and remains in the same state (reference ETS 300 172 [1], subclause 10.2.3).

SP065

- Ensure that the IUT in state 19, on second expiry of T308, (places the Information channel in a maintenance condition, releases the call reference), enters state 0 (reference ETS 300 172 [1], subclause 10.2.3).

PSS1_BC/PC/PI/SE/CC/ TC0501CZ

- Ensure that the IUT in state 19, on second expiry of T308, enters state 0 (reference ETS 300 172 [1], subclause 10.2.3).

5.3.2.2 Clear Collision

The TPs in this subclause refer to ETS 300 172 [1], subclause 10.2.4

SP066

- Ensure that the IUT in state 11, on receiving a DISCONNECT message, sends a RELEASE message and enters state 19 (reference ETS 300 172 [1], subclause 10.2.4).

PSS1_BC/PC/BI/SE/CC/ TC0001DI

- Ensure that the IUT in state 11, on receiving a DISCONNECT message, sends a RELEASE message and enters state 19 (reference ETS 300 172 [1], subclause 10.2.4).

SP067

- Ensure that the IUT in state 19, on receiving a RELEASE message, (releases the Information channel and the call reference, stops T308), and enters state 0 (reference ETS 300 172 [1], subclause 10.2.4).

PSS1_BC/PC/BI/SE/CC/ TC0001DJ

- Ensure that the IUT in state 19, on receiving a RELEASE message, enters state 0 (reference ETS 300 172 [1], subclause 10.2.4).

5.3.2.3 Exception conditions

The TPs in this subclause refer to ETS 300 172 [1], subclause 10.2.2

SP068

- Ensure that the IUT in state 1, in order to clear the call, sends a RELEASE message containing a Cause IE and enters state 19 (reference ETS 300 172 [1], subclause 10.2.2).

PSS1_BC/PC/BV/SE/CC/ TC0201DK

- Ensure that the IUT in state 1, in order to clear the call, sends a RELEASE message containing a Cause IE and enters state 19 (reference ETS 300 172 [1], subclause 10.2.2).

PSS1_BC/PC/BV/PV/CC/ TC0211DL

- Ensure that the IUT in state 1, in order to clear the call, sends a RELEASE message containing a Cause IE (reference ETS 300 172 [1], subclause 10.2.2).

5.3.3 Protocol Control requirements for Message Segmentation

The TPs in this subclause refer to ETS 300 172 [1], annex ZA

5.3.3.1 Procedures for segmentation

The TPs in this subclause refer to ETS 300 172 [1], subclause ZA.3.1.

The TPs in this subclause are only applicable to an IUT if it is declared in the PICS that it supports segmentation.

SP069

- Ensure that the IUT in state 0, in order to send a SETUP message exceeding the maximum implemented SCM information field length, sends 2 to 8 SEGMENT messages, each containing the same Call Reference IE and a Segmented Message IE with the First Segment Indicator field encoded as 1 in the first message and as 0 in all other messages, with the Number Of Segments Remaining field encoded as 0 in the last message and incremented by 1 for each SEGMENT message before the last, with a Segmented Message Type field encoded as SETUP, and each SEGMENT message containing 1 or more octets following the Segmented Message IE, which form, in the correct order, IEs permitted in a SETUP message (excluding Protocol Discriminator IE, Call Reference IE, Message Type IE), when concatenated from all the SEGMENT messages (reference ETS 300 172 [1], subclause ZA.3.1).

PSS1_BC/PC/CA/PV/MS/ TC0112EL

- Ensure that the IUT in state 0, in order to send a SETUP message exceeding the maximum implemented SCM information field length, sends 2 to 8 SEGMENT messages, with each containing the same Call Reference IE (reference ETS 300 172 [1], subclause ZA.3.1).

PSS1_BC/PC/BV/PV/MS/ TC0212EM

- Ensure that the IUT in state 0, in order to send a SETUP message exceeding the maximum implemented SCM information field length, sends a SEGMENT message containing a Segmented Message IE with the First Segment Indicator field encoded as 1 (reference ETS 300 172 [1], subclause ZA.3.1).

PSS1_BC/PC/BV/PV/MS/ TC0212EN

- Ensure that the IUT in state 0, in order to send a SETUP message exceeding the maximum implemented SCM information field length, sends 2 to 8 SEGMENT messages, with second and subsequent messages containing a Segmented Message IE with the First Segment Indicator field encoded as 0 (reference ETS 300 172 [1], subclause ZA.3.1).

PSS1_BC/PC/BV/PV/MS/ TC0212EO

- Ensure that the IUT in state 0, in order to send a SETUP message exceeding the maximum implemented SCM information field length, sends 2 to 8 SEGMENT messages, with second and subsequent messages containing a Segmented Message IE with the Number Of Segments Remaining field decremented by 1 from the value in the previous SEGMENT message (reference ETS 300 172 [1], subclause ZA.3.1).

PSS1_BC/PC/BV/PV/MS/ TC0212EP

- Ensure that the IUT in state 0, in order to send a SETUP message exceeding the maximum implemented SCM information field length, sends 2 to 8 SEGMENT messages, with the last message containing a Segmented Message IE with the Number Of Segments Remaining field encoded as 0 (reference ETS 300 172 [1], subclause ZA.3.1).

PSS1_BC/PC/BV/PV/MS/ TC0212EQ

- Ensure that the IUT in state 0, in order to send a SETUP message exceeding the maximum implemented SCM information field length, sends 2 to 8 SEGMENT messages, with all messages containing a Segmented Message IE with a Segmented Message Type field encoded as SETUP (reference ETS 300 172 [1], subclause ZA.3.1).

PSS1_BC/PV/BV/PC/MS/ TC0212ER

- Ensure that the IUT in state 0, in order to send a SETUP message exceeding the maximum implemented SCM information field length, sends 2 to 8 SEGMENT messages, with each message containing 1 or more octets following the Segmented Message IE, which form, in the correct order, IEs permitted in a SETUP message (excluding Protocol Discriminator IE, Call Reference IE, Message Type IE), when concatenated from all the SEGMENT messages (reference ETS 300 172 [1], subclause ZA.3.1).

5.3.3.2 Procedures for reassembly

The TPs in this subclause refer to ETS 300 172 [1], subclause ZA.3.2

The TPs in this subclause are only applicable to an IUT if it is declared in the PICS that it supports reassembly.

NOTE: Except where otherwise specified all messages in each of these TPs are sent using the same call reference.

SP070

- Ensure that the IUT in Call state 0 and in Reassembly null state, on receiving 2 to 8 SEGMENT messages, together forming a segmented SETUP message, sends a SETUP ACK, CALL PROCEEDING or RELEASE COMPLETE message (reference ETS 300 172 [1], subclause ZA.3.2).

PSS1_BC/PC/CA/PV/MS/ TC0112ES

- Ensure that the IUT in Call state 0 and in Reassembly null state, on receiving 2 SEGMENT messages, together forming a segmented SETUP message, sends a SETUP ACK, CALL PROCEEDING or RELEASE COMPLETE message (reference ETS 300 172 [1], subclause ZA.3.2).

PSS1_BC/PC/CA/PV/MS/ TC0112ET

- Ensure that the IUT in Call state 0 and in Reassembly null state, on receiving 5 SEGMENT messages, together forming a segmented SETUP message, sends a SETUP ACK, CALL PROCEEDING or RELEASE COMPLETE message (reference ETS 300 172 [1], subclause ZA.3.2).

PSS1_BC/PC/CA/PV/MS/ TC0112EU

- Ensure that the IUT in Call state 0 and in Reassembly null state, on receiving 8 SEGMENT messages, together forming a segmented SETUP message, sends a SETUP ACK, CALL PROCEEDING or RELEASE COMPLETE message (reference ETS 300 172 [1], subclause ZA.3.2).

SP304

- Ensure that the IUT, in any call state and in the Reassembly null state, on receiving a message, other than a SEGMENT message, passes that message for further Protocol Control processing (reference ETS 300 172 [1], subclause ZA.3.2.f).

PSS1_BC/PC/BV/PV/MS/ TC0212YE

- Ensure that the IUT in state 10 and in the Reassembly null state, on receiving an unsegmented DISCONNECT message sends a RELEASE message (reference ETS 300 172 [1], subclauses ZA.3.2.f and 10.2.3).

SP305

- Ensure that the IUT, in any call state and in the Reassembly null state, on receiving a message which is too short to contain a message type, passes that message for further Protocol Control processing (reference ETS 300 172 [1], subclause ZA.3.2.f).

PSS1_BC/PC/IV/PV/MS/ TC0312YF

- Ensure that the IUT in state 10 and in the Reassembly null state, on receiving a message too short to contain a Message Type IE, does not send any message in response to the received message and remains in the same state (reference ETS 300 172 [1], subclauses ZA.3.2.f and 9.2.2).

SP071

- Ensure that the IUT in any Call state except state 0, and in Reassembly null state, on receiving a SEGMENT message, not containing a Segmented Message IE, discards that message and remains in the same state (reference ETS 300 172 [1], subclause ZA.3.2.g).

PSS1_BC/PC/IV/PV/MS/ TC0312EV

- Ensure that the IUT in Call state 10 and in Reassembly null state, on receiving a SEGMENT message, not containing a Segmented Message IE, discards that message and remains in the same state (reference ETS 300 172 [1], subclause ZA.3.2.g).

SP072

- Ensure that the IUT in any Call state and in Reassembly null state, on receiving a SEGMENT message containing a Segmented Message IE with the First Segment Indicator field encoded as 0, discards that message and remains in the same state (reference ETS 300 172 [1], subclause ZA.3.2.g).

PSS1_BC/PC/IO/PV/MS/ TC0412EW

- Ensure that the IUT in Call state 10 and in Reassembly null state, on receiving a SEGMENT message containing a Segmented Message IE with the First Segment Indicator field encoded as 0, discards that message and remains in the same state (reference ETS 300 172 [1], subclause ZA.3.2.g).

SP073

- Ensure that the IUT in any Call state and in Reassembly null state, on receiving a SEGMENT message containing a Segmented Message IE with the First Segment Indicator field encoded as 1 and with the Number Of Segments Remaining field encoded as greater than 7, discards that message and remains in the same state (reference ETS 300 172 [1], subclause ZA.3.2.g).

PSS1_BC/PC/IV/PV/MS/ TC0312EX

- Ensure that the IUT in Call state 10 and in Reassembly null state, on receiving a SEGMENT message containing a Segmented Message IE with the First Segment Indicator field encoded as 1 and with the Number Of Segments Remaining field encoded as 8, discards that message and remains in the same state (reference ETS 300 172 [1], subclause ZA.3.2.g).

SP074

- Ensure that the IUT in any Call state and in Reassembly null state, on receiving a SEGMENT message containing a Segmented Message IE with the First Segment Indicator field encoded as 1, with the Number Of Segments Remaining field encoded as 0 and with the Segmented Message Type encoded as a valid message type for the Call state and with all the mandatory IEs for the message type after the Segmented Message IE, discards that message and remains in the same state (reference ETS 300 172 [1], subclause ZA.3.2.g).

PSS1_BC/PV/IV/PC/MS/ TC0312EY

- Ensure that the IUT in Call state 10 and in Reassembly null state, on receiving a SEGMENT message containing a Segmented Message IE with the First Segment Indicator field encoded as 1, with the Number Of Segments Remaining field encoded as 0 and with the Segmented Message Type encoded as DISCONNECT and with Cause IE after the Segmented Message IE, discards that message and remains in the same state (reference ETS 300 172 [1], subclause ZA.3.2.g).

SP075

- Ensure that the IUT in any Call state and in ReceivingSegmentedMessage state, on receiving an unsegmented message (other than SETUP, RELEASE or RELEASE COMPLETE) specifying a Call Reference different from that in the received SEGMENT message, processes that message normally (reference ETS 300 172 [1], subclause ZA.3.2.h).

PSS1_BC/PV/IO/PC/MS/ TC0412EZ

- Ensure that the IUT in Call state 10 and in ReceivingSegmentedMessage state, after having received a SEGMENT message containing a Call Reference IE with a Call Reference Value encoded as CR1 and containing a Segmented Message IE with a Segmented Message Type field encoded as PROGRESS, on receiving a CONNECT ACK message containing a Call Reference IE with a Call Reference Value encoded as CR2 (not in use for any call), sends a RELEASE COMPLETE message containing a Call Reference IE with a Call Reference Value encoded as CR2 and containing a Cause IE with a Cause Value encoded as 81 (reference ETS 300 172 [1], subclause ZA.3.2.h).

SP076

- Ensure that the IUT, in any Call state and in ReceivingSegmentedMessage state, on receiving an unsegmented message specifying a Call Reference different from that in the received SEGMENT message, enters Reassembly null state (reference ETS 300 172 [1], subclause ZA.3.2.h).

PSS1_BC/PC/IO/SE/MS/ TC0402FA

- Ensure that the IUT in Call state 0 and in ReceivingSegmentedMessage state, after having received a SEGMENT message containing a Call Reference IE with a Call Reference Value encoded as CR1 and containing a Segmented Message IE with a Segmented Message Type field encoded as SETUP, on receiving a RELEASE COMPLETE message containing a Call Reference IE with a Call Reference Value encoded as CR2 (not in use for any call), enters ReassemblyNull state.

This is verified by sending a SEGMENT message to the IUT, completing the segmented SETUP message, and ensuring that the IUT does not respond to that message (reference ETS 300 172 [1], subclause ZA.3.2.h).

SP077

- Ensure that the IUT, in any Call state and in ReceivingSegmentedMessage state, on receiving an unsegmented message with the same call reference value responds normally to that message (reference ETS 300 172 [1], subclause ZA.3.2.h).

PSS1_BC/PC/IO/PV/MS/ TC0412FB

- Ensure that the IUT in Call state 10 and in ReceivingSegmentedMessage state, after having received a SEGMENT message containing a Segmented Message IE with a Segmented Message Type field encoded as PROGRESS, on receiving a DISCONNECT message with the same call reference value, sends a RELEASE message (reference ETS 300 172 [1], subclause ZA.3.2.h).

SP078

- Ensure that the IUT, in any Call state and in ReceivingSegmentedMessage state, on receiving an unsegmented message with the same call reference value, enters Reassembly Null state (reference ETS 300 172 [1], subclause ZA.3.2.h).

PSS1_BC/PC/IO/SE/MS/ TC0402FC

- Ensure that the IUT in Call state 0 and in ReceivingSegmentedMessage state, after having received the first segment of a segmented SETUP message, on receiving a RELEASE COMPLETE message with the same call reference value, enters ReassemblyNull state.

This is verified by sending a SEGMENT message to the IUT, completing the segmented SETUP message, and ensuring that the IUT does not respond to that message (reference ETS 300 172 [1], subclause ZA.3.2.h).

SP079

- Ensure that the IUT in any Call state and in ReceivingSegmentedMessage state, on receiving a SEGMENT message containing a Segmented Message IE with a First Segment Indicator field encoded as 1 and a Segmented Message Type field encoded as a message that would normally cause a response, does not respond to that message (reference ETS 300 172 [1], subclause ZA.3.2.h).

PSS1_BC/PV/IO/PC/MS/ TC0412FD

- Ensure that the IUT in Call state 0 and in ReceivingSegmentedMessage state, after having received a SEGMENT message containing a Segmented Message IE with a Segmented Message Type field encoded as SETUP, with a First Segment Indicator field encoded as 1, with a Number Of Segments Remaining encoded as 1, on receiving a SEGMENT message containing a Segmented Message IE with a Segmented Message Type field encoded as DISCONNECT, with a First Segment Indicator field encoded as 1 and with a Number Of Segments Remaining encoded as 1, does not send any message (reference ETS 300 172 [1], subclause ZA.3.2.h).

SP080

- Ensure that the IUT in any Call state and in ReceivingSegmentedMessage state, on receiving a SEGMENT message containing a Segmented Message IE with a First Segment Indicator field encoded as 1 and a Segmented Message Type field encoded as a message that would normally cause a response, and on receiving a SEGMENT message completing the original segmented message that was being received, does not respond to that message (reference ETS 300 172 [1], subclause ZA.3.2.h).

PSS1_BC/PC/IO/SE/MS/ TC0402FE

- Ensure that the IUT in Call state 0 and in ReceivingSegmentedMessage state, after having received a SEGMENT message containing a Segmented Message IE with a Segmented Message Type field encoded as SETUP, with a First Segment Indicator field encoded as 1, with a Number Of Segments Remaining encoded as 1, on receiving a SEGMENT message containing a Segmented Message IE with a Segmented Message Type field encoded as DISCONNECT, with a First Segment Indicator field encoded as 1 and with a Number Of Segments Remaining encoded as 1, and on receiving a SEGMENT message containing a Segmented Message IE with a Segmented Message Type field encoded as SETUP, with a First Segment Indicator field encoded as 0, with a Number Of Segments Remaining encoded as 0 completing the segmented SETUP message, does not respond to that message (reference ETS 300 172 [1], subclause ZA.3.2.h).

SP081

- Ensure that the IUT in any Call state and in ReceivingSegmentedMessage state, on receiving a SEGMENT message containing a Segmented Message IE with a First Segment Indicator field encoded as 1 and a Segmented Message Type field encoded as a message that would normally cause a response, and on receiving a SEGMENT message completing the second segmented message that was being received, does not respond to that message (reference ETS 300 172 [1], subclause ZA.3.2.h).

PSS1_BC/PC/IO/SE/MS/ TC0402FF

- Ensure that the IUT in Call state 0 and in ReceivingSegmentedMessage state, after having received a SEGMENT message containing a Segmented Message IE with a Segmented Message Type field encoded as SETUP, with a First Segment Indicator field encoded as 1, with a Number Of Segments Remaining encoded as 1, on receiving a SEGMENT message containing a Segmented Message IE with a Segmented Message Type field encoded as DISCONNECT, with a First Segment Indicator field encoded as 1 and with a Number Of Segments Remaining encoded as 1, and on receiving a SEGMENT message containing a Segmented Message IE with a Segmented Message Type field encoded as DISCONNECT, with a First Segment Indicator field encoded as 0, with a Number Of Segments Remaining encoded as 0 completing the segmented CONNECT message, does not respond to that message (reference ETS 300 172 [1], subclause ZA.3.2.h).

SP082

- Ensure that the IUT, in any Call state and in ReceivingSegmentedMessage state, on receiving a SEGMENT message not containing a Segmented Message IE, remains in the same Call state (reference ETS 300 172 [1], subclause ZA.3.2.h).

PSS1_BC/PC/IV/SE/MS/ TC0302FG

- Ensure that the IUT, in Call state 10 and in ReceivingSegmentedMessage state, after having received a SEGMENT message containing a Segmented Message IE with a Segmented Message Type field encoded as PROGRESS, on receiving a SEGMENT message not containing a Segmented Message IE, remains in the same Call state (reference ETS 300 172 [1], subclause ZA.3.2.h).

SP083

- Ensure that the IUT in any Call state and in ReceivingSegmentedMessage state, on receiving a SEGMENT message not containing a Segmented Message IE, and on receiving a SEGMENT message completing the segmented message that was being received, does not respond to that message and remains in the same Call state (reference ETS 300 172 [1], subclause ZA.3.2.h).

PSS1_BC/PC/IV/SE/MS/ TC0302FH

- Ensure that the IUT in Call state 0 and in ReceivingSegmentedMessage state, after having received a SEGMENT message containing a Segmented Message IE with a Segmented Message Type field encoded as SETUP, on receiving a SEGMENT message not containing a Segmented Message IE, and on receiving a SEGMENT message completing the segmented SETUP message, does not respond to that message, and remains in the same Call state (reference ETS 300 172 [1], subclause ZA.3.2.h).

SP084

- Ensure that the IUT in any Call state and in ReceivingSegmentedMessage state, on receiving a SEGMENT message containing a Segmented Message IE with a Number Of Segments Remaining field encoded as a number, different than the number in the previous message decremented by one, remains in the same Call state (reference ETS 300 172 [1], subclause ZA.3.2.h).

PSS1_BC/PC/IV/PV/MS/ TC0312FI

- Ensure that the IUT in Call state 10 and in ReceivingSegmentedMessage state, after having received a SEGMENT message containing a Segmented Message IE with a Segmented Message Type field encoded as PROGRESS, with a Number Of Segments Remaining field encoded as 2, on receiving a SEGMENT message containing a Segmented Message IE with a Number Of Segments Remaining field encoded as 2, remains in the same Call state (reference ETS 300 172 [1], subclause ZA.3.2.h).

SP085

- Ensure that the IUT in any Call state and in ReceivingSegmentedMessage state, on receiving a SEGMENT message containing a Segmented Message IE with a Number Of Segments Remaining field encoded as a number not one less than in the previous message, and on receiving a SEGMENT message continuing the segmented message that was being received, does not respond to that message and remains in the same Call state (reference ETS 300 172 [1], subclause ZA.3.2.h).

PSS1_BC/PC/IV/SE/MS/ TC0302FJ

- Ensure that the IUT in Call state 0 and in ReceivingSegmentedMessage state, after having received a SEGMENT message containing a Segmented Message IE with a Segmented Message Type field encoded as SETUP, with a Number Of Segments Remaining field encoded as 1, on receiving a SEGMENT message containing a Segmented Message IE with a Number Of Segments Remaining field encoded as 1, and on receiving a SEGMENT message completing the segmented SETUP message, does not respond to that message and remains in the same Call state (reference ETS 300 172 [1], subclause ZA.3.2.h).

SP086

- Ensure that the IUT in any Call state and in ReceivingSegmentedMessage state, on receiving a SEGMENT message containing a Segmented Message IE with a Segmented Message Type field encoded differently from the previous message but which otherwise would have completed the segmented message, remains in the same Call state (reference ETS 300 172 [1], subclause ZA.3.2.h).

PSS1_BC/PC/IV/PV/MS/ TC0312FK

- Ensure that the IUT in Call state 10 and in ReceivingSegmentedMessage state, after having received a SEGMENT message containing a Segmented Message IE with a Segmented Message Type field encoded as PROGRESS, on receiving a SEGMENT message completing the segmented PROGRESS message, but containing a Segmented Message IE with a Segmented Message Type field encoded as SETUP, remains in the same Call state (reference ETS 300 172 [1], subclause ZA.3.2.h).

SP087

- Ensure that the IUT in any Call state and in ReceivingSegmentedMessage state, on receiving a SEGMENT message containing a Segmented Message IE with a Segmented Message Type field encoded differently from the previous message but which otherwise would have completed the segmented message, and on receiving a SEGMENT message completing the segmented message that was being received, does not respond to that message and remains in the same Call state (reference ETS 300 172 [1], subclause ZA.3.2.h).

PSS1_BC/PC/IV/SE/MS/ TC0302FL

- Ensure that the IUT in Call state 0 and in ReceivingSegmentedMessage state, after having received a SEGMENT message containing a Segmented Message IE with a Segmented Message Type field encoded as SETUP, on receiving a SEGMENT message completing the segmented SETUP message, but containing a Segmented Message IE with a Segmented Message Type field encoded as PROGRESS, and on receiving a SEGMENT message completing the segmented SETUP message, does not respond to that message and remains in the same Call state (reference ETS 300 172 [1], subclause ZA.3.2.h).

SP088

- Ensure that the IUT in any Call state and in ReceivingSegmentedMessage state, on expiry of T314, remains in the same Call state (reference ETS 300 172 [1], subclause ZA.3.2.i).

PSS1_BC/PC/CA/PV/MS/ TC0112FM

- Ensure that the IUT in Call state 4 and in ReceivingSegmentedMessage state, after having received a SEGMENT message containing a Segmented Message IE with a Segmented Message Type field encoded as CONNECT, on expiry of T314, remains in the same Call state (reference ETS 300 172 [1], subclause ZA.3.2.i).

SP089

- Ensure that the IUT in any Call state and in ReceivingSegmentedMessage state, on expiry of T314, and on receiving a SEGMENT message completing the segmented message that was being received, does not respond to that message, and remains in the same Call state (reference ETS 300 172 [1], subclause ZA.3.2.i).

PSS1_BC/PC/TI/SE/MS/ TC0502FN

- Ensure that the IUT in Call state 0 and in ReceivingSegmentedMessage state, after having received a SEGMENT message containing a Segmented Message IE with a Segmented Message Type field encoded as SETUP, after expiry of T314, on receiving a SEGMENT message completing the segmented SETUP message, does not respond to that message, and remains in the same Call state (reference ETS 300 172 [1], subclause ZA.3.2.i).

5.3.4 Protocol Control requirements for STATUS procedures

The TPs in this subclause refer to ETS 300 172 [1], subclause 9.3

5.3.4.1 Receiving a STATUS message

The TPs in this subclause refer to ETS 300 172 [1], subclause 9.3.2

SP090

- Ensure that the IUT in state 0, on receiving a STATUS message containing a Call Reference IE with a Call Reference Value encoded as other than the Global Call Reference and containing a Call State IE with a Call State Value encoded as other than 0, sends a RELEASE COMPLETE or RELEASE message containing a Cause IE with a Cause Value encoded as 101 (reference ETS 300 172 [1], subclause 9.3.2.1).

PSS1_BC/PC/BV/PV/ST/ TC0213SA

- Ensure that the IUT in state 0, on receiving a STATUS message containing a Call Reference IE with a Call Reference Value encoded as other than the Global Call Reference and containing a Call State IE with a Call State Value encoded as 3, sends a RELEASE COMPLETE or RELEASE message containing a Cause IE with a Cause Value encoded as 101 (reference ETS 300 172 [1], subclause 9.3.2.1).

SP091

- Ensure that the IUT in state 19, on receiving a STATUS message containing a Call State IE with a Call State Value encoded as other than 0 remains in the same state (reference ETS 300 172 [1], subclause 9.3.2.1).

PSS1_BC/PC/BV/SE/ST/ TC0203SB

- Ensure that the IUT in state 19, on receiving a STATUS message containing a Call State IE with a Call State Value encoded as 4, remains in the same state (reference ETS 300 172 [1], subclause 9.3.2.1).

SP092

- Ensure that the IUT in state 1, 2, 3, 4, 7, 8, 9, 10, 11, 19, or 25 on receiving a STATUS message containing a Call State IE with a Call State Value encoded as 0, enters state 0 (reference ETS 300 172 [1], subclause 9.3.2.1).

PSS1_BC/PC/BV/SE/ST/ TC0203SC

- Ensure that the IUT in state 1, on receiving a STATUS message containing a Call State IE with a Call State Value encoded as 0, enters state 0 (reference ETS 300 172 [1], subclause 9.3.2.1).

PSS1_BC/PC/BV/SE/ST/ TC0203SD

- Ensure that the IUT in state 4, on receiving a STATUS message containing a Call State IE with a Call State Value encoded as 0, enters state 0 (reference ETS 300 172 [1], subclause 9.3.2.1).

PSS1_BC/PC/BV/SE/ST/ TC0203SE

- Ensure that the IUT in state 9, on receiving a STATUS message containing a Call State IE with a Call State Value encoded as 0, enters state 0 (reference ETS 300 172 [1], subclause 9.3.2.1).

PSS1_BC/PC/BV/SE/ST/ TC0203SF

- Ensure the IUT in state 10, on receiving a STATUS message containing a Call State IE with a Call State Value encoded as 0, enters state 0 (reference ETS 300 172 [1], subclause 9.3.2.1).

PSS1_BC/PC/BV/SE/ST/ TC0203SG

- Ensure that the IUT in state 19, on receiving a STATUS message containing a Call State IE with a Call State Value encoded as 0, enters state 0 (reference ETS 300 172 [1], subclause 9.3.2.1).

SP093

- Ensure that the IUT in state 0, on receiving a STATUS message containing a Call State IE with a Call State Value encoded as 0 remains in the same state (reference ETS 300 172 [1], subclause 9.3.2.1).

PSS1_BC/PC/BV/SE/ST/ TC0203SH

- Ensure that the IUT in state 0, on receiving a STATUS message containing a Call State IE with a Call State Value encoded as 0, remains in the same state (reference ETS 300 172 [1], subclause 9.3.2.1).

SP094

- Ensure that the IUT in state 1,2,3,4,7,8,9,10,11,19 or 25, on receiving a STATUS message containing a Call State IE with a Call State Value encoded as a compatible state and containing a Cause IE with a Cause Value encoded as other than 96 or 97 or 99 or 100, remains in the same state (reference ETS 300 172 [1], subclause 9.3.2.2).

PSS1_BC/PC/BV/SE/ST/ TC0203SI

- Ensure that the IUT in state 2, on receiving a STATUS message containing a Call State IE with a Call State Value encoded as 25 and containing a Cause IE with a Cause Value encoded as other than 96 or 97 or 99 or 100, remains in the same state (reference ETS 300 172 [1], subclause 9.3.2.2).

PSS1_BC/PC/BV/SE/ST/ TC0203SJ

- Ensure that the IUT in state 7, on receiving a STATUS message containing a Call State IE with a Call State Value encoded as 4 and containing a Cause IE with a Cause Value encoded as other than 96 or 97 or 99 or 100, remains in the same state (reference ETS 300 172 [1], subclause 9.3.2.2).

PSS1_BC/PC/BV/SE/ST/ TC0203SK

- Ensure that the IUT in state 8, on receiving a STATUS message containing a Call State IE with a Call State Value encoded as 10 and containing a Cause IE with a Cause Value encoded as other than 96 or 97 or 99 or 100, remains in the same state (reference ETS 300 172 [1], subclause 9.3.2.2).

PSS1_BC/PC/BV/SE/ST/ TC0203SL

- Ensure that the IUT in state 11, on receiving a STATUS message containing a Call State IE with a Call State Value encoded as 12 and containing a Cause IE with a Cause Value encoded as other than 96 or 97 or 99 or 100, remains in the same state (reference ETS 300 172 [1], subclause 9.3.2.2)

PSS1_BC/PC/BV/SE/ST/ TC0203SM

- Ensure that the IUT in state 25, on receiving a STATUS message containing a Call State IE with a Call State Value encoded as 2 and containing a Cause IE with a Cause Value encoded as other than 96 or 97 or 99 or 100, remains in the same state (reference ETS 300 172 [1], subclause 9.3.2.2).

SP095

- Ensure that the IUT in Layer Management state R0 or R1, on receiving a STATUS message containing a Call Reference IE with a Call Reference Value encoded as the Global Call Reference and a Call State IE with a Call State Value encoded as a Layer Management compatible state, remains in the same state (reference ETS 300 172 [1], subclause 9.3.2.3).

PSS1_BC/PC/BV/SE/ST/ TC0203SN

- Ensure that the IUT in Layer Management state R0, on receiving a STATUS message containing a Call Reference IE with a Call Reference Value encoded as the Global Call Reference and a Call State IE with a Call State Value encoded as R0, remains in the same state (reference ETS 300 172 [1], subclause 9.3.2.3).

PSS1_BC/PC/BV/SE/ST/ TC0203SO

- Ensure that the IUT in Layer Management state R1, on receiving a STATUS message containing a Call Reference IE with a Call Reference Value encoded as the Global Call Reference and a Call State IE with a Call State Value encoded as R2, remains in the same state (reference ETS 300 172 [1], subclause 9.3.2.3).

5.3.4.2 Status enquiry procedure

The TPs in this subclause refer to ETS 300 172 [1], subclause 9.3.1.

SP096

- Ensure that the IUT in state 1,2,3,4,7,8,9,10,11,19 or 25, on receiving a STATUS ENQUIRY message, sends a STATUS message containing a Call State IE with a Call State Value encoded as the current state of the IUT and a Cause IE with a Cause Value encoded as 30 (reference ETS 300 172 [1], subclause 9.3.1).

PSS1_BC/PC/BV/PV/ST/ TC0213SP

- Ensure that the IUT in state 2, on receiving a STATUS ENQUIRY message, sends a STATUS message containing a Call State IE with a Call State Value encoded as state 2 and a Cause IE with a Cause Value encoded as 30 (reference ETS 300 172 [1], subclause 9.3.1).

PSS1_BC/PC/BV/PV/ST/ TC0213SQ

- Ensure that the IUT in state 3, on receiving a STATUS ENQUIRY message, sends a STATUS message containing a Call State IE with a Call State Value encoded as state 3 and a Cause IE with a Cause Value encoded as 30 (reference ETS 300 172 [1], subclause 9.3.1).

PSS1_BC/PC/BV/PV/ST/ TC0213SR

- Ensure that the IUT in state 8, on receiving a STATUS ENQUIRY message, sends a STATUS message containing a Call State IE with a Call State Value encoded as state 8 and a Cause IE with a Cause Value encoded as 30 (reference ETS 300 172 [1], subclause 9.3.1).

PSS1_BC/PC/BV/PV/ST/ TC0213SS

- Ensure that the IUT in state 9, on receiving a STATUS ENQUIRY message, sends a STATUS message containing a Call State IE with a Call State Value encoded as state 9 and a Cause IE with a Cause Value encoded as 30 (reference ETS 300 172 [1], subclause 9.3.1).

PSS1_BC/PC/CA/PV/ST/ TC0113ST

- Ensure that the IUT in state 11, on receiving a STATUS ENQUIRY message, sends a STATUS message containing a Call State IE with a Call State Value encoded as state 11 and a Cause IE with a Cause Value encoded as 30 (reference ETS 300 172 [1], subclause 9.3.1).

SP097

- Ensure that the IUT in state 1,2,3,4,7,8,9,10,11,19 or 25, after having sent a STATUS ENQUIRY message, on first expiry of timer T322, without receiving a STATUS message, sends a STATUS ENQUIRY message and remains in the same state (reference ETS 300 172 [1], subclause 9.3.1).

This STP and its derived TPs are only applicable to IUTs which re-transmit the STATUS ENQUIRY message.

PSS1_BC/PC/BV/PV/ST/ TC0213SU

- Ensure that the IUT in state 2, after having sent a STATUS ENQUIRY message, on first expiry of timer T322, without receiving a STATUS message, sends a STATUS ENQUIRY message and remains in the same state (reference ETS 300 172 [1], subclause 9.3.1).

PSS1_BC/PC/BV/PV/ST/ TC0213EB

- Ensure that the IUT in state 25, after having sent a STATUS ENQUIRY message, on first expiry of timer T322, without receiving a STATUS message, sends a STATUS ENQUIRY message and remains in the same state (reference ETS 300 172 [1], subclause 9.3.1).

STP098 to SP105 and their derived TPs are only applicable to an IUT if support of Sending of a STATUS ENQUIRY message is declared in the PICS.

SP098

- Ensure that the IUT in state 1,2,3,4,7,8,9,10,11,19 or 25, after having sent a STATUS ENQUIRY message, on occurrence of an event which would usually provoke the sending of a STATUS ENQUIRY, does not re-start T322, does not send a STATUS ENQUIRY message until expiry of T322 and remains in the same state (reference ETS 300 172 [1], subclause 9.3.1).

PSS1_BC/PC/BV/PV/ST/ TC0213SV

- Ensure that the IUT in state 3, after having sent a STATUS ENQUIRY message, on occurrence of an event which would usually provoke the sending of a STATUS ENQUIRY, does not re-start T322, does not send a STATUS ENQUIRY message until expiry of T322 and remains in the same state (reference ETS 300 172 [1], subclause 9.3.1).

PSS1_BC/PC/BV/PV/ST/ TC0213EC

- Ensure that the IUT in state 7, after having sent a STATUS ENQUIRY message, on occurrence of an event which would usually provoke the sending of a STATUS ENQUIRY, does not re-start T322, does not send a STATUS ENQUIRY message until expiry of T322 and remains in the same state (reference ETS 300 172 [1], subclause 9.3.1).

SP099

- Ensure that the IUT in state 1, after having sent the maximum implemented number of STATUS ENQUIRY messages, as stated in the PIXIT, on expiry of timer T322, sends a RELEASE message containing a Cause IE with a Cause Value encoded as 41 and enters state 19 (reference ETS 300 172 [1], subclause 9.3.1).

NOTE: This STP is referenced in 'Untestable TPs' section in the associated ATS specification document.

SP100

- Ensure that the IUT in state 2,3,4,7,8,9,10 or 25, after having sent the maximum implemented number of STATUS ENQUIRY messages, as stated in the PIXIT, on expiry of timer T322, sends a DISCONNECT message containing a Cause IE with a Cause Value encoded as 41, and enters state 11 (reference ETS 300 172 [1], subclause 9.3.1).

PSS1_BC/PC/BV/PV/ST/ TC0213SX

- Ensure that the IUT in state 4, after having sent the maximum implemented number of STATUS ENQUIRY messages, as stated in the PIXIT, on expiry of timer T322, sends a DISCONNECT message containing a Cause IE with a Cause Value encoded as 41, and enters state 11 (reference ETS 300 172 [1], subclause 9.3.1).

PSS1_BC/PC/BV/PV/ST/ TC0213ED

- Ensure that the IUT in state 10, after having sent the maximum implemented number of STATUS ENQUIRY messages, as stated in the PIXIT, on expiry of timer T322, sends a DISCONNECT message containing a Cause IE with a Cause Value encoded as 41, and enters state 11 (reference ETS 300 172 [1], subclause 9.3.1).

SP101

- Ensure that the IUT in state 1,2,3,4,7,8,9,10,11,19 or 25, after having sent a STATUS ENQUIRY message, on receiving a STATUS message containing a Cause IE with a Cause Value encoded as other than 30, does not send any further STATUS ENQUIRY message(s) until expiry of T322 and remains in the same state (reference ETS 300 172 [1], subclause 9.3.1).

PSS1_BC/PC/BV/PV/ST/ TC0213SY

- Ensure that the IUT in state 4, after having sent a STATUS ENQUIRY message, on receiving a STATUS message containing a Cause IE with a Cause Value encoded as other than 30, does not send any further STATUS ENQUIRY message(s) until expiry of T322 and remains in the same state (reference ETS 300 172 [1], subclause 9.3.1).

PSS1_BC/PC/BV/PV/ST/ TC0213EF

- Ensure that the IUT in state 25, after having sent a STATUS ENQUIRY message, on receiving a STATUS message containing a Cause IE with a Cause Value encoded as other than 30, does not send any further STATUS ENQUIRY messages until expiry of T322 and remains in the same state (reference ETS 300 172 [1], subclause 9.3.1).

SP102

- Ensure that the IUT in state 1,2,3,4,7,8,9,10,11,19 or 25, after having sent a STATUS ENQUIRY message, on receiving a STATUS message with a Cause IE with a Cause Value encoded as 30, stops timer T322 and remains in the same state (reference ETS 300 172 [1], subclause 9.3.1).

PSS1_BC/PC/CA/PV/ST/ TC0113SZ

- Ensure that the IUT in state 3, after having sent a STATUS ENQUIRY message, on receiving a STATUS message with a Cause IE with a Cause Value encoded as 30 remains in the same state (reference ETS 300 172 [1], subclause 9.3.1).

PSS1_BC/PC/BV/PV/ST/ TC0213EG

- Ensure that the IUT in state 25, after having sent a STATUS ENQUIRY message, on receiving a STATUS message with a Cause IE with a Cause Value encoded as 30, stops timer T322 and remains in the same state (reference ETS 300 172 [1], subclause 9.3.1).

SP103

- Ensure that the IUT in state 2,3,4,7,8,9,10,11,19 or 25, after having sent a STATUS ENQUIRY message, on receiving a DISCONNECT message, stops timer T322, sends a RELEASE message and enters state 19 (reference ETS 300 172 [1], subclause 9.3.1).

PSS1_BC/PC/BV/PV/ST/ TC0213WA

- Ensure that the IUT in state 7 after having sent a STATUS ENQUIRY message, on receiving a DISCONNECT message, stops timer T322, sends a RELEASE message and enters state 19 (reference ETS 300 172 [1], subclause 9.3.1).

PSS1_BC/PC/BV/PV/ST/ TC0213EH

- Ensure that the IUT in state 10, after having sent a STATUS ENQUIRY message, on receiving a DISCONNECT message, stops timer T322, sends a RELEASE message and enters state 19 (reference ETS 300 172 [1], subclause 9.3.1).

SP104

- Ensure that the IUT in state 1,2,3,4,7,8,9,10,11,19 or 25, after having sent a STATUS ENQUIRY message, on receiving a RELEASE message, stops timer T322, sends a RELEASE COMPLETE message and enters state 0 (reference ETS 300 172 [1], subclause 9.3.1).

PSS1_BC/PC/BV/PV/ST/ TC0213WB

- Ensure that the IUT in state 2, after having sent a STATUS ENQUIRY message, on receiving a RELEASE message, stops timer T322, sends a RELEASE COMPLETE message and enters state 0 (reference ETS 300 172 [1], subclause 9.3.1).

PSS1_BC/PC/BV/PV/ST/ TC0213EI

- Ensure that the IUT in state 10, after having sent a STATUS ENQUIRY message, on receiving a RELEASE message, stops timer T322, sends a RELEASE COMPLETE message and enters state 0 (reference ETS 300 172 [1], subclause 9.3.1).

SP105

- Ensure that the IUT in state 1,2,3,4,7,8,9,10,11,19 or 25, after having sent a STATUS ENQUIRY message, on receiving a RELEASE COMPLETE message, stops timer T322, and enters state 0 (reference ETS 300 172 [1], subclause 9.3.1).

PSS1_BC/PC/BV/PV/ST/ TC0213WC

- Ensure that the IUT in state 9, after having sent a STATUS ENQUIRY message, on receiving a RELEASE COMPLETE message, stops timer T322, and enters state 0 (reference ETS 300 172 [1], subclause 9.3.1).

PSS1_BC/PC/BV/PV/ST/ TC0213EK

- Ensure that the IUT in state 10, after having sent a STATUS ENQUIRY message, on receiving a RELEASE COMPLETE message, stops timer T322, and enters state 0 (reference ETS 300 172 [1], subclause 7.4.1).

5.3.5 Protocol Control requirements for Layer Management

The TPs in this subclause refer to ETS 300 172 [1], clause 11.

5.3.5.1 Sending a RESTART

The TPs in this subclause refer to ETS 300 172 [1], subclause 11.1.1.

SP106

- Ensure that the IUT in Layer Management state R0, in order to restart channels, sends a RESTART message and enters Layer Management state R1 (reference ETS 300 172 [1], subclause 11.1.1).

PSS1_BC/PC/BV/PV/LM/ TC0214TA

- Ensure that the IUT in Layer Management state R0, in order to restart channels, sends a RESTART message and enters Layer Management state R1 (reference ETS 300 172 [1], subclause 11.1.1).

SP107

- Ensure that the IUT in Layer Management state R1, on the first expiry of timer T316 without having received a RESTART ACKNOWLEDGE message, sends a RESTART message and remains in the same state (reference ETS 300 172 [1], subclause 11.1.1).

PSS1_BC/PC/TI/PV/LM/ TC0514TB

- Ensure that the IUT in Layer Management state R1, on the first expiry of timer T316 without having received a RESTART ACKNOWLEDGE message, sends a RESTART message and remains in the same state (reference ETS 300 172 [1], subclause 11.1.1).

SP108

- Ensure that the IUT in Layer Management state R1, on receiving a RESTART ACKNOWLEDGE message indicating the same channel(s) as in the RESTART message sent by the IUT, stops timer T316 and enters Layer Management state R0 (reference ETS 300 172 [1], subclause 11.1.1).

PSS1_BC/PC/BV/SE/LM/ TC0204TC

- Ensure that the IUT in Layer Management state R1, on receiving a RESTART ACKNOWLEDGE message indicating the same channel(s) as in the RESTART message sent by the IUT, stops timer T316 and enters Layer Management state R0 (reference ETS 300 172 [1], subclause 11.1.1).

SP109

- Ensure that the IUT, in Layer Management state R1, on receiving a SETUP message containing a Channel Identification IE with a Channel Number encoded as in the RESTART message sent previously, either sends a CALL PROCEEDING or SETUP ACK message containing a Channel Identification IE with a Channel Number encoded as other than in the RESTART message and enters Call state 9 or 25 respectively, or sends a RELEASE COMPLETE message and enters Call state 0, and remains in Layer Management state R1 for both alternatives (reference ETS 300 172 [1], subclause 11.1.1).

PSS1_BC/PC/BV/PV/LM/ TC0214TD

- Ensure that the IUT, in Layer Management state R1, on receiving a SETUP message containing a Channel Identification IE with a Channel Number encoded as in the RESTART message sent previously, either sends a CALL PROCEEDING or SETUP ACK message containing a Channel Identification IE with a Channel Number encoded as other than in the RESTART message and enters Call state 9 or 25 respectively, or sends a RELEASE COMPLETE message and enters Call state 0, and remains in Layer Management state R1 for both alternatives (reference ETS 300 172 [1], subclause 11.1.1).

5.3.5.2 Receipt of RESTART

The TPs in this subclause refer to ETS 300 172 [1], subclause 11.1.2

SP110

- Ensure that the IUT in Layer Management state R0 with all call references in the Null state and all channels in the idle condition, on receiving a RESTART message containing a Restart Indicator IE with a Class Value encoded as "Indicated Channel" and a Channel Identification IE, sends a RESTART ACK message containing a Restart Indicator IE with a Class Value encoded as "Indicated Channel" and a Channel Identification IE with a Channel Number encoded as in the RESTART message, and returns to Layer Management state R0 (reference ETS 300 172 [1], subclause 11.1.2).

PSS1_BC/PC/CA/PV/LM/ TC0114TE

- Ensure that the IUT in Layer Management state R0 with all call references in the Null state and all channels in the idle condition, on receiving a RESTART message containing a Restart Indicator IE with a Class Value encoded as "Indicated Channel" and a Channel Identification IE, sends a RESTART ACK message containing a Restart Indicator IE with a Class Value encoded as "Indicated Channel" and a Channel Identification IE with a Channel Number encoded as in the RESTART message, and returns to Layer Management state R0 (reference ETS 300 172 [1], subclause 11.1.2).

SP111

- Ensure that the IUT in Layer Management state R0 with all call references in the Null state and all channels in the idle condition, on receiving a RESTART message containing a Restart Indicator IE with a Class Value encoded as "All Channels", sends a RESTART ACK message containing a Restart Indicator IE with a Class Value encoded as "All Channels" and returns to Layer Management state R0 (reference ETS 300 172 [1], subclause 11.1.2).

PSS1_BC/PC/CA/PV/LM/ TC0114TF

- Ensure that the IUT in Layer Management state R0 with all call references in the Null state and all channels in the idle condition, on receiving a RESTART message containing a Restart Indicator IE with a Class Value encoded as "All Channels", sends a RESTART ACK message containing a Restart Indicator IE with a Class Value encoded as "All Channels" and returns to Layer Management state R0 (reference ETS 300 172 [1], subclause 11.1.2).

SP112

- Ensure that the IUT in layer Management state R0 and in Call state 1, 2, 3, 4, 6, 7, 9, 10, 11, 19 or 25 using Channel Number **n**, on receiving a RESTART message containing a Restart Indicator IE with a Class Value encoded as "Indicated Channel" and a Channel Identification IE with a Channel Number encoded as **n**, sends a RESTART ACK message containing a Restart Indicator IE with a Class Value encoded as "Indicated Channel" and a Channel Identification IE with a Channel Number encoded as **n**, enters state 0 for this call and returns to Layer Management state R0 (reference ETS 300 172 [1], subclause 11.1.2).

PSS1_BC/PC/BV/PV/LM/ TC0214TG

- Ensure that the IUT in layer Management state R0 and in Call state 10 using Channel Number **n**, on receiving a RESTART message containing a Restart Indicator IE with a Class Value encoded as "Indicated Channel" and a Channel Identification IE with a Channel Number encoded as **n**, sends a RESTART ACK message containing a Restart Indicator IE with a Class Value encoded as "Indicated Channel" and a Channel Identification IE with a Channel Number encoded as **n**, and enters state 0 for this call (reference ETS 300 172 [1], subclause 11.1.2).

SP113

- Ensure that the IUT in layer Management state R0 and in Call state 1, 2, 3, 4, 6, 7, 9, 10, 11 19 or 25 using Channel Number **n**, on receiving a RESTART message containing a Restart Indicator IE with a Class Value encoded as "All Channels", sends a RESTART ACK message containing a Restart Indicator IE with a Class Value encoded as "All Channels", enters state 0 for this call and returns to Layer Management state R0 (reference ETS 300 172 [1], subclause 11.1.2).

PSS1_BC/PC/BV/PV/LM/ TC0214TH

- Ensure that the IUT in layer Management state R0 and in Call state 10 using Channel Number **n**, on receiving a RESTART message containing a Restart Indicator IE with a Class Value encoded as "All Channels", sends a RESTART ACK message containing a Restart Indicator IE with a Class Value encoded as "All Channels", enters state 0 for this call (reference ETS 300 172 [1], subclause 11.1.2).

SP301

- Ensure that the IUT in layer Management state R0 with a call in any state, on receiving a RESTART message containing a Restart Indicator IE with a Class Value encoded as "Indicated Channel" and not containing a Channel Identification IE, sends a STATUS message containing a Cause IE with the Cause Value encoded as 96 "mandatory information element is missing" and remains in the same protocol control state. (reference ETS 300 172 [1], subclauses 11.1.2 and 9.2.6.1).

PSS1_BC/PC/IV/PV/LM/ TC0314YD

- Ensure that the IUT in layer Management state R0 and in call state 10, on receiving a RESTART message containing a Restart Indicator IE with a Class Value encoded as "Indicated Channel" and not containing a Channel Identification IE, sends a STATUS message containing a Cause IE with the Cause Value encoded as 96 "mandatory information element is missing" and remains in the same protocol control state. (reference ETS 300 172 [1], subclauses 11.1.2 and 9.2.6.1).

5.3.5.3 Restart Collision

The TPs in this subclause refer to (ETS 300 172 [1], subclause 11.1.3)

SP114

- Ensure that the IUT in Layer Management state R1, on receiving a RESTART message containing a Restart Indicator IE with a Class Value encoded as "Indicated Channel" and a Channel Identification IE with a Channel Number encoded as **n**, sends a RESTART ACK message containing a Restart Indicator IE with a Class Value encoded as "Indicated Channel" and a Channel Identification IE with a Channel Number encoded as **n**, returns to Layer Management state R0 for the incoming RESTART and remains in state R1 for the outgoing RESTART (reference ETS 300 172 [1], subclause 11.1.3).

PSS1_BC/PC/BV/PV/LM/ TC0214TI

- Ensure that the IUT in Layer Management state R1, on receiving a RESTART message containing a Restart Indicator IE with a Class Value encoded as "Indicated Channel" and a Channel Identification IE with a Channel Number encoded as **n**, sends a RESTART ACK message containing a Restart Indicator IE with a Class Value encoded as "Indicated Channel" and a Channel Identification IE with a Channel Number encoded as **n**, returns to Layer Management state R0 for the incoming RESTART and remains in state R1 for the outgoing RESTART (reference ETS 300 172 [1], subclause 11.1.3).

SP115

Ensure that the IUT in Layer Management state R1, on receiving a RESTART message containing a Restart Indicator IE with a Class Value encoded as "All Channels", sends a RESTART ACK message containing a Restart Indicator IE with a Class Value encoded as "All Channels", returns to Layer Management state R0 for the incoming RESTART and remains in state R1 for the outgoing RESTART (reference ETS 300 172 [1], subclause 11.1.3).

PSS1_BC/PC/BV/PV/LM/ TC0214TJ

- Ensure that the IUT in Layer Management state R1, on receiving a RESTART message containing a Restart Indicator IE with a Class Value encoded as "All Channels", sends a RESTART ACK message containing a Restart Indicator IE with a Class Value encoded as "All Channels", returns to Layer Management state R0 for the incoming RESTART and remains in state R1 for the outgoing RESTART (reference ETS 300 172 [1], subclause 11.1.3).

SP116

- Ensure that the IUT in layer Management state R1 and in Call state 1, 2, 3, 4, 6, 7, 9, 10, 11, 19 or 25 using Channel Number **n**, on receiving a RESTART message containing a Restart Indicator IE with a Class Value encoded as "Indicated Channel" and a Channel Identification IE with a Channel Number encoded as **n**, sends a RESTART ACK message containing a Restart Indicator IE with a Class Value encoded as "Indicated Channel" and a Channel Identification IE with a Channel Number encoded as **n**, enters state 0 for this call and returns to Layer Management state R0 for the incoming RESTART (reference ETS 300 172 [1], subclause 11.1.3).

PSS1_BC/PC/BV/PV/LM/ TC0214TK

- Ensure that the IUT in layer Management state R1 and in Call state 10 using Channel Number **n**, on receiving a RESTART message containing a Restart Indicator IE with a Class Value encoded as "Indicated Channel" and a Channel Identification IE with a Channel Number encoded as **n**, sends a RESTART ACK message containing a Restart Indicator IE with a Class Value encoded as "Indicated Channel" and a Channel Identification IE with a Channel Number encoded as **n**, enters state 0 for this call and returns to Layer Management state R0 for the incoming RESTART (reference ETS 300 172 [1], subclause 11.1.3).

SP117

- Ensure that the IUT in layer Management state R1 and in Call state 1, 2, 3, 4, 6, 7, 9, 10, 11, 19 or 25 using Channel Number **n**, on receiving a RESTART message containing a Restart Indicator IE with a Class Value encoded as "All Channels", sends a RESTART ACK message containing a Restart Indicator IE with a Class Value encoded as "All Channels", enters state 0 for this call and returns to Layer Management state R0 for the incoming RESTART (reference ETS 300 172 [1], subclause 11.1.3).

PSS1_BC/PC/BV/PV/LM/ TC0214TL

- Ensure that the IUT in layer Management state R1 and in Call state 10 using Channel Number **n**, on receiving a RESTART message containing a Restart Indicator IE with a Class Value encoded as "All Channels", sends a RESTART ACK message containing a Restart Indicator IE with a Class Value encoded as "All Channels", enters state 0 for this call and returns to Layer Management state R0 for the incoming RESTART (reference ETS 300 172 [1], subclause 11.1.3).

SP307

- Ensure that the IUT in layer Management state R1 after sending a RESTART message applicable to channel **n**, on receiving a RESTART message applicable to channel **n**, sends a RESTART ACK message, and on receipt of a SETUP message containing a Channel identification IE with the preferred/exclusive bit encoded as exclusive and the channel number encoded as **n**, sends a RELEASE COMPLETE message with a Cause IE with cause number 44 (requested circuit/channel not available) (reference ETS 300 172 [1], subclause 11.1.3).

NOTE: If the RESTART message sent by the IUT is for an indicated channel then **n** is that channel; if it is for all channels then **n** can be any channel.

PSS1_BC/PC/BV/PV/LM/ TC0214YH

- Ensure that the IUT in layer Management state R1 after sending a RESTART message applicable to channel **n**, on receiving a RESTART message containing a Restart Indicator IE with a Class Value encoded as "All Channels", sends a RESTART ACK message, and on receipt of a SETUP message containing a Channel identification IE with the preferred/exclusive bit encoded as exclusive and the channel number encoded as **n**, sends a RELEASE COMPLETE message with a Cause IE with cause number 44 (requested circuit/channel not available) (reference ETS 300 172 [1], subclause 11.1.3).

PSS1_BC/PC/BV/PV/LM/ TC0214YI

- Ensure that the IUT in layer Management state R1 after sending a RESTART message applicable to channel **n**, on receiving a RESTART message containing a Restart Indicator IE with a Class Value encoded as "Indicated channel" and a Channel identification IE with the channel number encoded as **n**, sends a RESTART ACK message, and on receipt of a SETUP message containing a Channel identification IE with the preferred/exclusive bit encoded as exclusive and the channel number encoded as **n**, sends a RELEASE COMPLETE message with a Cause IE with cause number 44 (requested circuit/channel not available) (reference ETS 300 172 [1], subclause 11.1.3).

5.3.6 Protocol Control requirements for handling of protocol error conditions

The TPs in this subclause refer to ETS 300 172 [1], subclause 9.2

5.3.6.1 Protocol discriminator error

The TPs in this subclause refer to ETS 300 172 [1], subclause 9.2.1.

SP118

- Ensure that the IUT, on receiving a message containing a Protocol Discriminator IE encoded with a value other than 8, does not send any message in response to the received message and remains in the same state (reference ETS 300 172 [1], subclause 9.2.1).

PSS1_BC/PC/CA/PV/ST/ TC0113IG

- Ensure that the IUT in state 10, on receiving a STATUS ENQUIRY message containing a Protocol Discriminator IE encoded as other than 8, remains in the same state and does not send any message in response to the received message (reference ETS 300 172 [1], subclause 9.2.1).

5.3.6.2 Message too short

The TPs in this subclause refer to ETS 300 172 [1], subclause 9.2.2

SP119

- Ensure that the IUT, on receiving a message too short to contain a Message Type IE, does not send any message in response to the received message and remains in the same state (reference ETS 300 172 [1], subclause 9.2.2).

PSS1_BC/PC/IV/PV/CC/ TC0311FO

- Ensure that the IUT in state 10, on receiving a message too short to contain a Message Type IE, does not send any message in response to the received message and remains in the same state (reference ETS 300 172 [1], subclause 9.2.2).

5.3.6.3 Call reference error

The TPs in this subclause refer to ETS 300 172 [1], subclause 9.2.3

5.3.6.3.1 Invalid call reference format

The TPs in this subclause refer to ETS 300 172 [1], subclause 9.2.3.1.

SP120

- Ensure that the IUT, on receiving a message containing a Call Reference IE with bits 5 to 8 of octet 1 encoded as other than '0000', does not send any message in response to the received message and remains in the same state (reference ETS 300 172 [1], subclause 9.2.3.1).

PSS1_BC/PC/IV/PV/CE/ TC0310FP

- Ensure that the IUT in state 25, on receiving a STATUS message containing a Call Reference IE with bits 5 to 8 of octet 1 encoded as other than '0000' and with the rest of the Call Reference correctly coded, and a Call State IE with a Call State value encoded as 0, does not send any message in response to the received message and remains in the same state (reference ETS 300 172 [1], subclause 9.2.3.1).

PSS1_BC/PC/IV/PV/CE/ TC0310FQ

- Ensure that the IUT in state 1, on receiving a SETUP ACK message containing a Call Reference IE with bits 5 to 8 of octet 1 encoded as other than '0000', and with the rest of the Call Reference correctly coded, does not send any message in response to the received message and remains in the same state (reference ETS 300 172 [1], subclause 9.2.3.1).

SP121

- Ensure that the IUT, on receiving a message containing a Call Reference IE with bits 1 to 4 of octet 1 encoded as greater than 2, does not send any message in response to the received message and remains in the same state (reference ETS 300 172 [1], subclause 9.2.3.1).

PSS1_BC/PC/IV/PV/CE/ TC0310FR

- Ensure that the IUT in state 1, on receiving a CALL PROCEEDING message containing a Call Reference IE with bits 1 to 4 of octet 1 encoded as 3, does not send any message in response to the received message and remains in the same state. The Call Reference for the call is encoded in 3 octets (reference ETS 300 172 [1], subclause 9.2.3.1).

PSS1_BC/PC/IV/PV/CE/ TC0310FS

- Ensure that the IUT in state 25, on receiving an INFORMATION message containing a Call Reference IE with bits 1 to 4 of octet 1 encoded as 3 and a Sending Complete IE, does not send any message in response to the received message and remains in the same state. The Call Reference for the call is encoded in 3 octets (reference ETS 300 172 [1], subclause 9.2.3.1).

SP122

- Ensure that the IUT, on receiving a message containing a Call Reference IE with a Call Reference Value encoded as the Dummy Call Reference, does not send any message in response to the received message (reference ETS 300 172 [1], subclause 9.2.3.1).

PSS1_BC/PC/IV/PV/CE/ TC0310FT

- Ensure that the IUT in state 0, on receiving a SETUP message containing a Call Reference IE with a Call Reference Value encoded as the Dummy Call Reference, does not send any message in response to the received message (reference ETS 300 172 [1], subclause 9.2.3.1).

PSS1_BC/PC/IV/PV/CC/ TC0310FU

- Ensure that the IUT in state 10, on receiving a DISCONNECT message containing a Call Reference IE with a Call Reference Value encoded as the Dummy Call Reference, remains in the same state and does not send any message in response to the received message (reference ETS 300 172 [1], subclause 9.2.3.1).

5.3.6.3.2 Call Reference procedural errors

The TPs in this subclause refer to ETS 300 172 [1], subclause 9.2.3.2.

SP123

- Ensure that the IUT, on receiving a message other than SETUP, STATUS, RELEASE or RELEASE COMPLETE containing a Call Reference IE with a Call Reference Value encoded as a call reference CR not relating to an active call or a call in progress (i.e. in state 0 for this call reference), sends a RELEASE COMPLETE or RELEASE message containing a Call Reference IE with a Call Reference Value encoded as CR and a Cause IE with a Cause Value encoded as 81 (reference ETS 300 172 [1], subclause 9.2.3.2).

PSS1_BC/PC/IO/PV/CC/ TC0411FV

- Ensure that the IUT, on receiving a CALL PROCEEDING message containing a Call Reference IE with a Call Reference Value encoded as a call reference CR not relating to an active call or a call in progress (i.e. in state 0 for this call reference), sends a RELEASE COMPLETE or RELEASE message containing a Call Reference IE with a Call Reference Value encoded as CR and a Cause IE with a Cause Value encoded as 81 (reference ETS 300 172 [1], subclause 9.2.3.2).

PSS1_BC/PC/IO/PV/CC/ TC0411FW

- Ensure that the IUT, on receiving a CONNECT message containing a Call Reference IE with a Call Reference Value encoded as a call reference CR not relating to an active call or a call in progress (i.e. in state 0 for this call reference), sends a RELEASE COMPLETE or RELEASE message containing a Call Reference IE with a Call Reference Value encoded as CR and a Cause IE with a Cause Value encoded as 81 (reference ETS 300 172 [1], subclause 9.2.3.2).

SP124

- Ensure that the IUT without any active calls or calls in progress, on receiving a SETUP message containing a Call Reference IE with a Call Reference Flag encoded as 1, does not send any message in response to the incoming message and remains in the same state (reference ETS 300 172 [1], subclause 9.2.3.2).

PSS1_BC/PC/IV/PV/CC/ TC0311FX

- Ensure that the IUT without any active calls or calls in progress, on receiving a SETUP message containing a Call Reference IE with a Call Reference Flag encoded as 1, does not send any message in response to the incoming message and remains in the same state (reference ETS 300 172 [1], subclause 9.2.3.2).

SP125

- Ensure that the IUT in state 0, on receiving a RELEASE message containing a Call Reference IE with a Call Reference Value encoded as a call reference CR not relating to an active call or a call in progress, sends a RELEASE COMPLETE message containing a Call Reference IE with a Call Reference Value encoded as CR and a Cause IE with a Cause Value encoded 81, and remains in the same state for this call (reference ETS 300 172 [1], subclause 9.2.3.2).

PSS1_BC/PC/IO/SE/CC/ TC0401FY

- Ensure that the IUT in state 0, on receiving a RELEASE message containing a Call Reference IE with a Call Reference Value encoded as a call reference CR not relating to an active call or a call in progress, sends a RELEASE COMPLETE message containing a Call Reference IE with a Call Reference Value encoded as CR and a Cause IE with a Cause Value encoded 81, and remains in the same state for this call (reference ETS 300 172 [1], subclause 9.2.3.2).

SP126

- Ensure that the IUT in state 0, on receiving a RELEASE COMPLETE message containing a Call Reference IE with a Call Reference Value not relating to an active call or a call in progress, does not send any message in response to the incoming message and remains in the same state for this call (reference ETS 300 172 [1], subclause 9.2.3.2).

PSS1_BC/PC/IO/SE/CC/ TC0401FZ

- Ensure that the IUT in state 0, on receiving a RELEASE COMPLETE message containing a Call Reference IE with a Call Reference Value not relating to an active call or a call in progress, does not send any message in response to the incoming message and remains in the same state for this call (reference ETS 300 172 [1], subclause 9.2.3.2).

SP127

- Ensure that the IUT in state 7, 8, 9, 10, 11, 19, or 25, on receiving a SETUP message containing a Call Reference IE with a Call Reference Value related to an active call or a call in progress, does not send any message in response to the incoming message and remains in the same state for this call (reference ETS 300 172 [1], subclause 9.2.3.2).

PSS1_BC/PC/IO/SE/CE/ TC0400GA

- Ensure that the IUT in state 9, on receiving a SETUP message containing a Call Reference IE with a Call Reference Value related to a call in progress, does not send any message in response to the incoming message and remains in the same state for this call (reference ETS 300 172 [1], subclause 9.2.3.2).

PSS1_BC/PC/IO/SE/CE/ TC0400GB

- Ensure that the IUT in state 10, on receiving a SETUP message containing a Call Reference IE with a Call Reference Value related to an active call, does not send any message in response to the incoming message and remains in the same state for this call (reference ETS 300 172 [1], subclause 9.2.3.2).

SP128

- Ensure that the IUT, on receiving a message other than RESTART, RESTART ACK or STATUS containing a Call Reference IE with a Call Reference Value encoded as the Global Call Reference, sends a STATUS message containing a Call Reference IE encoded as the Global Call Reference and a Cause IE with a Cause Value encoded as 81 (reference ETS 300 172 [1], subclause 9.2.3.2).

PSS1_BC/PC/IO/PV/LM/ TC0414GC

- Ensure that the IUT in state 1, on receiving a SETUP ACK message containing a Call Reference IE with a Call Reference Value encoded as the Global Call Reference, sends a STATUS message containing a Call Reference IE encoded as the Global Call Reference and a Cause IE with a Cause Value encoded as 81 (reference ETS 300 172 [1], subclause 9.2.3.2).

5.3.6.4 Message type or Message sequence errors

The TPs in this subclause refer to [1], subclause 9.2.4

SP129

- Ensure that the IUT in state 1, 2, 3, 4, 7, 8, 9, 10, 11, 19, or 25, on receiving a message containing a Message Type IE other than one of those specified in ETS 300 172 [1] and ETS 300 239 [2], either sends a STATUS message containing a Cause IE with a Cause Value encoded as 97 or 98, or sends a STATUS ENQUIRY message, and remains in the same state (reference ETS 300 172 [1], subclause 9.2.4).

PSS1_BC/PC/IV/PV/CE/ TC0310GD

- Ensure that the IUT in state 3, on receiving a message containing a Message Type IE other than one of those specified in ETS 300 172 [1] or ETS 300 239 [2], either sends a STATUS message containing a Cause IE with a Cause Value encoded as 97 or 98, or sends a STATUS ENQUIRY message, and remains in the same state (reference ETS 300 172 [1], subclause 9.2.4).

PSS1_BC/PC/IV/PV/CE/ TC0310GE

- Ensure that the IUT in state 11, on receiving a message containing a Message Type IE other than one of those specified in ETS 300 172 [1] or ETS 300 239 [2], either sends a STATUS message containing a Cause IE with a Cause Value encoded as 97 or 98, or sends a STATUS ENQUIRY message, and remains in the same state (reference ETS 300 172 [1], subclause 9.2.4).

SP130

- Ensure that the IUT in state 1, 2, 3, 4, 7, 8, 9, 10, 11, 19, or 25, on receiving a message other than RELEASE, RELEASE COMPLETE or SETUP which is unexpected in that state, either sends a STATUS message containing a Cause IE with a Cause Value encoded as 98 or 101, or sends a STATUS ENQUIRY message, and remains in the same state (reference ETS 300 172 [1], subclause 9.2.4).

PSS1_BC/PC/IO/SE/CE/ TC0400GF

- Ensure that the IUT in state 2, on receiving an CONNECT ACKNOWLEDGE message which is unexpected in that state, either sends a STATUS message containing a Cause IE with a Cause Value encoded as 98 or 101, or sends a STATUS ENQUIRY message, and remains in the same state (reference ETS 300 172 [1], subclause 9.2.4).

PSS1_BC/PC/IO/SE/CE/ TC0400GG

- Ensure that the IUT in state 8, on receiving a CALL PROCEEDING message which is unexpected in that state, either sends a STATUS message containing a Cause IE with a Cause Value encoded as 98 or 101, or sends a STATUS ENQUIRY message, and remains in the same state (reference ETS 300 172 [1], subclause 9.2.4).

SP131

- Ensure that the IUT in state 2, 3, 4, 7, 8, 9, 10, or 25, on receiving a RELEASE message, sends a RELEASE COMPLETE message and enters state 0 (reference ETS 300 172 [1], subclause 9.2.4).

PSS1_BC/PC/IO/SE/CC/ TC0401GH

- Ensure that the IUT in state 4, on receiving a RELEASE message, sends a RELEASE COMPLETE message and enters state 0 (reference ETS 300 172 [1], subclause 9.2.4).

PSS1_BC/PC/IO/SE/CC/ TC0401GI

- Ensure that the IUT in state 7, on receiving a RELEASE message, sends a RELEASE COMPLETE message and enters state 0 (reference ETS 300 172 [1], subclause 9.2.4).

PSS1_BC/PC/IO/SE/CC/ TC0401XS

- Ensure that the IUT in state 25, on receiving a RELEASE message, sends a RELEASE COMPLETE message and enters state 0 (reference ETS 300 172 [1], subclause 9.2.4).

SP132

- Ensure that the IUT in state 2, 3, 4, 7, 8, 9, 10, 11, or 25, on receiving a RELEASE COMPLETE message, enters state 0 (reference ETS 300 172 [1], subclause 9.2.4).

PSS1_BC/PC/IO/SE/CC/ TC0401GJ

- Ensure that the IUT in state 10, on receiving a RELEASE COMPLETE message, enters state 0 (reference ETS 300 172 [1], subclause 9.2.4).

PSS1_BC/PC/IO/SE/CC/ TC0401GK

- Ensure that the IUT in state 25, on receiving a RELEASE COMPLETE message, enters state 0 (reference ETS 300 172 [1], subclause 9.2.4).

PSS1_BC/PC/IO/SE/CC/ TC0401XT

- Ensure that the IUT in state 11, on receiving a RELEASE COMPLETE message, enters state 0 (reference ETS 300 172 [1], subclause 9.2.4).

5.3.6.5 General IE errors

The TPs in this subclause refer to ETS 300 172 [1], subclause 9.2.5.

5.3.6.5.1 Duplicated IEs

The TPs in this subclause refer to ETS 300 172 [1], subclause 9.2.5.1.

SP133

- Ensure that the IUT, on receiving a message containing two or more instances of an IE for which repetition is not permitted, behaves as though only the first had been received (reference ETS 300 172 [1], subclause 9.2.5.1).

PSS1_BC/PC/IV/PV/CE/ TC0310GL

- Ensure that the IUT in state 0, on receiving a SETUP message containing a first Channel Identification IE with a Channel Number encoded as **n** (known to be busy) and a Preferred/Exclusive field encoded as "Exclusive", and containing a second Channel Identification IE with a Channel Number encoded as **m** (known to be free), sends a RELEASE COMPLETE message containing a Cause IE with a Cause Value encoded as 44 (reference ETS 300 172 [1], subclause 9.2.5.1).

PSS1_BC/PC/IV/PV/CE/ TC0310GM

- Ensure that the IUT in state 1, after having sent a SETUP message containing a Channel Identification IE with a Channel Number encoded as **n**, on receiving a CALL PROCEEDING message containing a first Channel Identification IE with a Channel Number encoded with a non-existent channel number and containing a second Channel Identification IE with a Channel Number encoded as **n**, sends a RELEASE message containing a Cause IE with a Cause Value encoded as 6 (reference ETS 300 172 [1], subclause 9.2.5.1).

5.3.6.5.2 IEs exceeding maximum length

The TPs in this subclause refer to ETS 300 172 [1], subclause 9.2.5.2.

SP134

- Ensure that the IUT, on receiving a message, other than SETUP, DISCONNECT, RELEASE or RELEASE COMPLETE containing a mandatory IE with a length greater than the permitted maximum, sends a STATUS message containing a Cause IE with a Cause Value encoded as 100 and remains in the same state (reference ETS 300 172 [1], subclauses 9.2.5.2 and 9.2.6.2).

PSS1_BC/PC/IV/PV/LM/ TC0314GN

- Ensure that the IUT in state 11, on receiving a RESTART message containing a Restart Indicator IE with a length of 4 octets, sends a STATUS message containing a Cause IE with a Cause Value encoded as 100 and remains in the same state (reference ETS 300 172 [1], subclauses 9.2.5.2 and 9.2.6.2).

SP135

- Ensure that the IUT in state 0, on receiving a SETUP message containing a mandatory IE with a length greater than the permitted maximum, sends a RELEASE COMPLETE message containing a Cause IE with a Cause Value encoded as 100 (reference ETS 300 172 [1], subclauses 9.2.5.2 and 9.2.6.2).

PSS1_BC/PC/IV/PV/CE/ TC0310GO

- Ensure that the IUT in state 0, on receiving a SETUP message containing a Bearer Capability IE with a length of 12, sends a RELEASE COMPLETE message containing a Cause IE with a Cause Value encoded as 100 (reference ETS 300 172 [1], subclauses 9.2.5.2 and 9.2.6.2).

SP136

- Ensure that the IUT in state 2, 3, 4, 7, 8, 9, 10, or 25, on receiving a DISCONNECT message containing a Cause IE with a length greater than the permitted maximum, sends a RELEASE message containing a Cause IE with a Cause Value encoded as 100, and enters state 19 (reference ETS 300 172 [1], subclauses 9.2.5.2 and 9.2.6.2).

PSS1_BC/PC/IV/PV/CC/ TC0311GP

- Ensure that the IUT in state 10, on receiving a DISCONNECT message containing a Cause IE with a length of 33 octets, sends a RELEASE message containing a Cause IE with a Cause Value encoded as 100, and enters state 19 (reference ETS 300 172 [1], subclauses 9.2.5.2 and 9.2.6.2).

SP137

- Ensure that the IUT in state 1, on receiving a RELEASE message containing a Cause IE exceeding the maximum permitted length, sends a RELEASE COMPLETE message containing a Cause IE with a Cause Value encoded as 100 and enters state 0 (reference ETS 300 172 [1], subclauses 9.2.5.2 and 9.2.6.2).

PSS1_BC/PC/IV/PV/CC/ TC0311XO

- Ensure that the IUT in state 1, on receiving a RELEASE message containing a Cause IE with length 33 octets, sends a RELEASE COMPLETE message containing a Cause IE with a Cause Value encoded as 100 and enters state 0 (reference ETS 300 172 [1], subclauses 9.2.5.2 and 9.2.6.2).

SP138

- Ensure that the IUT, in state 1, on receiving a RELEASE COMPLETE message containing a Cause IE exceeding the maximum length, enters state 0 (reference ETS 300 172 [1], subclauses 9.2.5.2 and 9.2.6.2).

PSS1_BC/PC/IV/SE/CC/ TC0301XP

- Ensure that the IUT, in state 1, on receiving a RELEASE COMPLETE message containing a Cause IE with length 33 octets, enters state 0 (reference ETS 300 172 [1], subclauses 9.2.5.2 and 9.2.6.2).

5.3.6.6 Mandatory IE errors

The TPs in this subclause refer to ETS 300 172 [1], subclause 9.2.6.

5.3.6.6.1 Mandatory IEs missing

The TPs in this subclause refer to ETS 300 172 [1], subclause 9.2.6.1.

SP015

- Ensure that the IUT in state 1, on receiving a CALL PROCEEDING, SETUP ACKNOWLEDGE, ALERTING or CONNECT message without a Channel Identification Information element (IE), as the first response to the SETUP message, sends a STATUS message containing a Cause IE with a Cause Value encoded as 96, and remains in the same state (reference ETS 300 172 [1], subclauses 9.2.6.1 and 10.1.2).

PSS1_BC/PC/IV/SE/CE/ TC0300AV

- Ensure that the IUT in state 1, on receiving a CALL PROCEEDING message without a Channel Identification IE, as the first response to the SETUP message, sends a STATUS message, and remains in the same state (reference ETS 300 172 [1], subclauses 9.2.6.1 and 10.1.2).

PSS1_BC/PC/IV/PV/CE/ TC0310AW

- Ensure that the IUT in state 1, on receiving a SETUP ACKNOWLEDGE message without a Channel Identification IE, as the first response to the SETUP message, sends a STATUS message containing a Cause IE with a Cause Value encoded as 96 (reference ETS 300 172 [1], subclauses 9.2.6.1 and 10.1.2).

PSS1_BC/PC/IO/SE/CE/ TC0400AX

- Ensure that the IUT in state 1, on receiving an ALERTING message without a Channel Identification IE, as the first response to the SETUP message, sends a STATUS message, and remains in the same state (reference ETS 300 172 [1], subclauses 9.2.6.1 and 10.1.2).

PSS1_BC/PC/IO/PV/CE/ TC0410AY

- Ensure that the IUT in state 1, on receiving a CONNECT message without a Channel Identification IE, as the first response to the SETUP message, sends a STATUS message containing a Cause IE with a Cause Value encoded as 96 (reference ETS 300 172 [1], subclauses 9.2.6.1 and 10.1.2).

SP139

- Ensure that the IUT in any state, on receiving a message other than SETUP, DISCONNECT, RELEASE or RELEASE COMPLETE with one or more mandatory IEs missing, sends a STATUS message containing a Cause IE with a Cause Value encoded as 96 and remains in the same state (reference ETS 300 172 [1], subclause 9.2.6.1).

PSS1_BC/PC/IV/PV/CE/ TC0310GQ

- Ensure that the IUT in state 2, on receiving a PROGRESS message with a Progress Indicator IE missing, sends a STATUS message containing a Cause IE with a Cause Value encoded as 96 and remains in the same state (reference ETS 300 172 [1], subclause 9.2.6.1).

PSS1_BC/PC/IV/PV/CE/ TC0310GR

- Ensure that the IUT in state 8, on receiving a PROGRESS message with a Progress Indicator IE missing, sends a STATUS message containing a Cause IE with a Cause Value encoded as 96 and remains in the same state (reference ETS 300 172 [1], subclause 9.2.6.1).

SP140

- Ensure that the IUT in state 0, on receiving a SETUP message with one or more mandatory IEs missing, sends a RELEASE COMPLETE message containing a Cause IE with a Cause Value encoded as 96, and remains in state 0 (reference ETS 300 172 [1], subclause 9.2.6.1).

PSS1_BC/PC/IV/PV/CE/ TC0310GS

- Ensure that the IUT in state 0, on receiving a SETUP message with a Called Party Number IE missing, sends a RELEASE COMPLETE message containing a Cause IE with a Cause Value encoded as 96, and returns to state 0 (reference ETS 300 172 [1], subclause 9.2.6.1).

SP141

- Ensure that the IUT in state 2, 3, 4, 7, 8, 9, 10, or 25, on receiving a RELEASE message with one or more mandatory IEs missing, sends a RELEASE COMPLETE message containing a Cause IE with a Cause Value encoded as 96 and enters state 0. (reference ETS 300 172 [1], subclause 9.2.6.1).

PSS1_BC/PC/IV/PV/CC/ TC0311GT

- Ensure that the IUT in state 2, on receiving a RELEASE message as the first clearing message with a Cause IE missing, sends a RELEASE COMPLETE message containing a Cause IE with a Cause Value encoded as 96 and enters state 0 (reference ETS 300 172 [1], subclause 9.2.6.1).

PSS1_BC/PC/IV/PV/CC/ TC0311GU

- Ensure that the IUT in state 10, on receiving a RELEASE message as the first clearing message with a Cause IE missing, sends a RELEASE COMPLETE message containing a Cause IE with a Cause Value encoded as 96 and enters state 0 (reference ETS 300 172 [1], subclause 9.2.6.1).

SP142

- Ensure that the IUT in state 2, 3, 4, 7, 8, 9, 10, or 25, on receiving a RELEASE COMPLETE message as the first clearing message with one or more mandatory IEs missing, enters state 0 (reference ETS 300 172 [1], subclause 9.2.6.1).

PSS1_BC/PC/IV/PV/CC/ TC0311GV

- Ensure that the IUT in state 3, on receiving a RELEASE COMPLETE message as the first clearing message with a Cause IE missing, enters state 0 (reference ETS 300 172 [1], subclause 9.2.6.1).

PSS1_BC/PC/IV/PV/CC/ TC0311GW

- Ensure that the IUT in state 8, on receiving a RELEASE COMPLETE message as the first clearing message with a Cause IE missing, enters state 0 (reference ETS 300 172 [1], subclause 9.2.6.1).

SP143

- Ensure that the IUT in state 2, 3, 4, 7, 8, 9, 10, or 25, on receiving a DISCONNECT message with one or more mandatory IEs missing, sends a RELEASE message containing a Cause IE with a Cause Value encoded as 96 and enters state 19 (reference ETS 300 172 [1], subclause 9.2.6.1).

PSS1_BC/PC/IV/PV/CC/ TC0311GX

- Ensure that the IUT in state 4, on receiving a DISCONNECT message with a Cause IE missing, sends a RELEASE message containing a Cause IE with a Cause Value encoded as 96 and enters state 19 (reference ETS 300 172 [1], subclause 9.2.6.1).

PSS1_BC/PC/IV/PV/CC/ TC0311GY

- Ensure that the IUT in state 25, on receiving a DISCONNECT message with a Cause IE missing, sends a RELEASE message containing a Cause IE with a Cause Value encoded as 96 and enters state 19 (reference ETS 300 172 [1], subclause 9.2.6.1).

5.3.6.6.2 Mandatory IE content error

The TPs in this subclause refer to ETS 300 172 [1], subclause 9.2.6.2.

SP144

- Ensure that the IUT, on receiving a message, other than SETUP, DISCONNECT, RELEASE or RELEASE COMPLETE containing a mandatory IE encoded with a content error, sends a STATUS message containing a Cause IE with a Cause Value encoded as 100 and remains in the same state (reference ETS 300 172 [1], subclause 9.2.6.2).

PSS1_BC/PC/IV/PV/CE/ TC0310GZ

- Ensure that the IUT in state 1, on receiving an ALERTING message containing a Channel Identification IE encoded with a content error, sends a STATUS message containing a Cause IE with a Cause Value encoded as 100 and remains in the same state (reference ETS 300 172 [1], subclause 9.2.6.2).

PSS1_BC/PC/IV/PV/LM/ TC0314HA

- Ensure that the IUT in state 19, on receiving a RESTART message containing a Restart Indicator IE encoded with a content error, sends a STATUS message containing a Cause IE with a Cause Value encoded as 100 and remains in the same state (reference ETS 300 172 [1], subclause 9.2.6.2).

SP145

- Ensure that the IUT in state 0, on receiving a SETUP message containing a mandatory IE encoded with a content error, sends a RELEASE COMPLETE message containing a Cause IE with a Cause Value encoded as 100 (reference ETS 300 172 [1], subclause 9.2.6.2).

PSS1_BC/PC/IV/PV/CC/ TC0311HB

- Ensure that the IUT in state 0, on receiving a SETUP message containing a Channel Identification IE encoded with a content error, sends a RELEASE COMPLETE message containing a Cause IE with a Cause Value encoded as 100 (reference ETS 300 172 [1], subclause 9.2.6.2).

SP146

- Ensure that the IUT in state 2, 3, 4, 7, 8, 9, 10, or 25, on receiving a DISCONNECT message containing a Cause IE encoded with a content error, sends a RELEASE message containing a Cause IE with a Cause Value encoded as 100 and enters state 19 (reference ETS 300 172 [1], subclause 9.2.6.2).

PSS1_BC/PC/IV/PV/CC/ TC0311HC

- Ensure that the IUT in state 3, on receiving a DISCONNECT message containing a Cause IE encoded with a content error, sends a RELEASE message containing a Cause IE with a Cause Value encoded as 100 and enters state 19 (reference ETS 300 172 [1], subclause 9.2.6.2).

PSS1_BC/PC/IV/PV/CC/ TC0311HD

- Ensure that the IUT in state 8, on receiving a DISCONNECT message containing a Cause IE encoded with a content error, sends a RELEASE message containing a Cause IE with a Cause Value encoded as 100 and enters state 19 (reference ETS 300 172 [1], subclause 9.2.6.2).

SP147

- Ensure that the IUT in state 1, on receiving a RELEASE message containing a Cause IE encoded with a content error, sends a RELEASE COMPLETE message containing a Cause IE encoded as 100 and enters state 0 (reference ETS 300 172 [1], subclause 9.2.6.2).

PSS1_BC/PC/IV/PV/CC/ TC0311XQ

- Ensure that the IUT in state 1, on receiving a RELEASE message containing a Cause IE encoded with a content error, sends a RELEASE COMPLETE message containing a Cause IE encoded as 100 and enters state 0 (reference ETS 300 172 [1], subclause 9.2.6.2).

SP256

- Ensure that the IUT in state 1, on receiving a RELEASE COMPLETE message containing a Cause IE encoded with a content error, enters state 0 (reference ETS 300 172 [1], subclause 9.2.6.2).

PSS1_BC/PC/IV/SE/CC/ TC0301XR

- Ensure that the IUT in state 1, on receiving a RELEASE COMPLETE message containing a Cause IE encoded with a content error, enters state 0 (reference ETS 300 172 [1], subclause 9.2.6.2).

5.3.6.7 Non-mandatory IE errors

The TPs in this subclause refer to ETS 300 172 [1], subclause 9.2.7.

5.3.6.7.1 Non-mandatory IE not recognised

The TPs in this subclause refer to ETS 300 172 [1], subclause 9.2.7.1.

SP148

- Ensure that the IUT in any state, on receiving a message other than SETUP, DISCONNECT, RELEASE or RELEASE COMPLETE with one or more IEs which are unrecognised and coded as "comprehension required", sends a STATUS message containing a Cause IE with a Cause Value encoded as 96 and remains in the same state (reference ETS 300 172 [1], subclauses 9.2.7.1 and 9.2.6.1).

PSS1_BC/PC/IV/PV/CE/ TC0310HE

- Ensure that the IUT in state 1, on receiving a CONNECT message containing an unrecognised IE coded as "comprehension required", sends a STATUS message containing a Cause IE with a Cause Value encoded as 96 and remains in the same state (reference ETS 300 172 [1], subclauses 9.2.7.1 and 9.2.6.1).

PSS1_BC/PC/IV/PV/CE/ TC0310HF

- Ensure that the IUT in state 8, on receiving a CONNECT ACK message containing an unrecognised IE coded as "comprehension required", sends a STATUS message containing a Cause IE with a Cause Value encoded as 96 and remains in the same state (reference ETS 300 172 [1], subclauses 9.2.7.1 and 9.2.6.1).

SP149

- Ensure that the IUT in state 0, on receiving a SETUP message containing one or more IEs which are unrecognised and coded as "comprehension required", sends a RELEASE COMPLETE message containing a Cause IE with a Cause Value encoded as 96, and returns to state 0.(reference ETS 300 172 [1], subclauses 9.2.7.1 and 9.2.6.1).

PSS1_BC/PC/IV/PV/CE/ TC0310XX

- Ensure that the IUT in state 0, on receiving a SETUP message containing an unrecognised IE coded as "comprehension required", sends a RELEASE COMPLETE message containing a Cause IE with a Cause Value encoded as 96, and returns to state 0 (reference ETS 300 172 [1], subclauses 9.2.7.1 and 9.2.6.1).

SP150

- Ensure that the IUT in state 2, 3, 4, 7, 8, 9, 10, or 25, on receiving a RELEASE message containing one or more IEs which are unrecognised and coded as "comprehension required", sends a RELEASE COMPLETE message containing a Cause IE with a Cause Value encoded as 96 and enters state 0 (reference ETS 300 172 [1], subclauses 9.2.7.1 and 9.2.6.1).

PSS1_BC/PC/IV/PV/CC/ TC0311HH

- Ensure that the IUT in state 3, on receiving a RELEASE message containing an unrecognised IE coded as "comprehension required", sends a RELEASE COMPLETE message containing a Cause IE with a Cause Value encoded as 96 and enters state 0 (reference ETS 300 172 [1], subclauses 9.2.7.1 and 9.2.6.1).

PSS1_BC/PC/IV/PV/CC/ TC0311HI

- Ensure that the IUT in state 8, on receiving a RELEASE message containing an unrecognised IE coded as "comprehension required", sends a RELEASE COMPLETE message containing a Cause IE with a Cause Value encoded as 96 and enters state 0 (reference ETS 300 172 [1], subclauses 9.2.7.1 and 9.2.6.1).

SP151

- Ensure that the IUT in state 2, 3, 4, 7, 8, 9, 10, or 25, on receiving a RELEASE COMPLETE message containing one or more IEs which are unrecognised and coded as "comprehension required", enters state 0 (reference ETS 300 172 [1], subclauses 9.2.7.1 and 9.2.6.1).

PSS1_BC/PC/IV/SE/CC/ TC0301HJ

- Ensure that the IUT in state 4, on receiving a RELEASE COMPLETE message containing an unrecognised IE coded as "comprehension required", enters state 0 (reference ETS 300 172 [1], subclauses 9.2.7.1 and 9.2.6.1).

PSS1_BC/PC/IV/SE/CC/ TC0301HK

- Ensure that the IUT in state 10, on receiving a RELEASE COMPLETE message containing an unrecognised IE coded as "comprehension required", enters state 0 (reference ETS 300 172 [1], subclauses 9.2.7.1 and 9.2.6.1).

SP152

- Ensure that the IUT in state 2, 3, 4, 7, 8, 9, 10, or 25, on receiving a DISCONNECT message containing one or more IEs which are unrecognised and coded as "comprehension required", sends a RELEASE message containing a Cause IE with a Cause Value encoded as 96 and enters state 19 (reference ETS 300 172 [1], subclauses 9.2.7.1 and 9.2.6.1).

PSS1_BC/PC/IV/PV/CC/ TC0311HL

- Ensure that the IUT in state 2, on receiving a DISCONNECT message containing an unrecognised IE coded as "comprehension required", sends a RELEASE message containing a Cause IE with a Cause Value encoded as 96 and enters state 19 (reference ETS 300 172 [1], subclauses 9.2.7.1 and 9.2.6.1).

PSS1_BC/PC/IV/PV/CC/ TC0311HM

- Ensure that the IUT in state 25, on receiving a DISCONNECT message containing an unrecognised IE coded as "comprehension required", sends a RELEASE message containing a Cause IE with a Cause Value encoded as 96 and enters state 19 (reference ETS 300 172 [1], subclauses 9.2.7.1 and 9.2.6.1).

SP153

- Ensure that the IUT in state 2, 3, 4, 7, 8, 9, 10, or 25, on receiving a DISCONNECT message containing one or more IEs which are unrecognised and coded as "comprehension not required", sends a RELEASE message containing a Cause IE with a Cause Value encoded as 99 and enters state 19 (reference ETS 300 172 [1], subclause 9.2.7.1).

PSS1_BC/PC/IV/PV/CC/ TC0311HN

- Ensure that the IUT in state 3, on receiving a DISCONNECT message containing one or more IEs with an unrecognised IE coded as "comprehension not required", sends a RELEASE message containing a Cause IE with a Cause Value encoded as 99 and enters state 19 (reference ETS 300 172 [1], subclause 9.2.7.1).

PSS1_BC/PC/IV/PV/CC/ TC0311HO

- Ensure that the IUT in state 10, on receiving a DISCONNECT message containing an unrecognised IE coded as "comprehension not required", sends a RELEASE message containing a Cause IE with a Cause Value encoded as 99 and enters state 19 (reference ETS 300 172 [1], subclause 9.2.7.1).

SP154

- Ensure that the IUT in state 2, 3, 4, 7, 8, 9, 10, or 25, on receiving a RELEASE message containing one or more IEs which are unrecognised and coded as "comprehension not required", sends a RELEASE COMPLETE message containing a Cause IE with a Cause Value encoded as 99 and enters state 19 (reference ETS 300 172 [1], subclause 9.2.7.1).

PSS1_BC/PC/IV/PV/CC/ TC0311HP

- Ensure that the IUT in state 4, on receiving a RELEASE message containing an unrecognised IE coded as "comprehension not required", sends a RELEASE COMPLETE message containing a Cause IE with Cause Value encoded as 99 and enters state 0 (reference ETS 300 172 [1], subclause 9.2.7.1).

PSS1_BC/PC/IV/PV/CC/ TC0311HQ

- Ensure that the IUT in state 25, on receiving a RELEASE message containing an unrecognised IE coded as "comprehension not required", sends a RELEASE COMPLETE message containing a Cause IE with Cause Value encoded as 99 and enters state 0 (reference ETS 300 172 [1], subclause 9.2.7.1).

SP155

- Ensure that the IUT in state 2, 3, 4, 7, 8, 9, 10, or 25, on receiving a RELEASE COMPLETE message containing one or more IEs which are unrecognised and coded as "comprehension not required", enters state 0 (reference ETS 300 172 [1], subclause 9.2.7.1).

PSS1_BC/PC/IV/SE/CC/ TC0301HR

- Ensure that the IUT in state 2, on receiving a RELEASE COMPLETE message containing an unrecognised IE coded as "comprehension not required", enters state 0 (reference ETS 300 172 [1], subclause 9.2.7.1).

PSS1_BC/PC/IV/SE/CC/ TC0301HS

- Ensure that the IUT in state 8, on receiving a RELEASE COMPLETE message containing an unrecognised IE coded as "comprehension not required", enters state 0 (reference ETS 300 172 [1], subclause 9.2.7.1).

SP156

- Ensure that the IUT in any state, on receiving a message other than DISCONNECT, RELEASE or RELEASE COMPLETE with one or more IEs which are unrecognised and coded as "comprehension not required", performs the appropriate action for the received message (ignoring the unrecognised IE) and optionally sends a STATUS message containing a Cause IE with a Cause Value encoded as 99 (reference ETS 300 172 [1], subclause 9.2.7.1).

PSS1_BC/PC/IV/PV/CE/ TC0310HT

- Ensure that the IUT in state 1, on receiving a SETUP ACK message containing an unrecognised IE coded as "comprehension not required", enters state 2 and optionally sends a STATUS message containing a Cause IE with a Cause Value encoded as 99 (reference ETS 300 172 [1], subclause 9.2.7.1).

PSS1_BC/PC/IV/PV/CE/ TC0310HU

- Ensure that the IUT in state 25, on receiving an INFORMATION message containing an unrecognised IE coded as "comprehension not required" and containing a Sending Complete IE, sends a CALL PROCEEDING message and optionally sends a STATUS message containing a Cause IE with a Cause Value encoded as 99 (reference ETS 300 172 [1], subclause 9.2.7.1).

5.3.6.7.2 Non-mandatory IE content error

The TPs in this subclause refer to ETS 300 172 [1], subclause 9.2.7.2

SP157

- Ensure that the IUT in any state, on receiving a message other than DISCONNECT, RELEASE or RELEASE COMPLETE with one or more non-mandatory IEs with invalid contents, performs the appropriate action for the received message (ignoring the invalid IE) and optionally sends a STATUS message containing a Cause IE with a Cause Value encoded as 100 (reference ETS 300 172 [1], subclause 9.2.7.2).

PSS1_BC/PC/IV/PV/CE/ TC0310HV

- Ensure that the IUT in state 3, on receiving an ALERTING message containing a Party Category IE with invalid content, enters state 4, ignoring the invalid IE, and optionally sends a STATUS message containing a Cause IE with a Cause Value encoded as 100 (reference ETS 300 172 [1], subclause 9.2.7.2).

PSS1_BC/PC/IV/PV/CE/ TC0310HW

- Ensure that the IUT in state 0, on receiving a SETUP message containing a Sending Complete IE and a Party Category IE with invalid content, sends a CALL PROCEEDING message, ignoring the invalid IE, and optionally sends a STATUS message containing a Cause IE with a Cause Value encoded as 100 (reference ETS 300 172 [1], subclause 9.2.7.2).

5.3.6.8 Signalling Carriage Mechanism reset

The TPs in this subclause refer to ETS 300 172 [1], subclause 9.2.8

SP162

- Ensure that the IUT in state 2 or 25, on receiving a DL_ESTABLISH_INDICATION primitive, sends a DISCONNECT message containing a Cause IE with a Cause Value encoded as 41 (reference ETS 300 172 [1] subclause 9.2.8).

NOTE: This STP is referenced in 'Untestable TPs ' section in the associated ATS specification document.

SP163

- Ensure that the IUT in state 11, 12 or 19, on receiving DL_ESTABLISH_INDICATION primitive, does not take any special action (reference ETS 300 172 [1] subclause 9.2.8).

NOTE: This STP is referenced in 'Untestable TPs' section in the associated ATS specification document.

SP164

- Ensure that the IUT in state 1, 3, 4, 6, 7, 8, 9 and 10, on receiving DL_ESTABLISH_INDICATION primitive optionally sends a STATUS or STATUS ENQUIRY message and remains in the same state (reference ETS 300 172 [1] subclause 9.2.8).

NOTE: This STP is referenced in 'Untestable TPs' section in the associated ATS specification document.

5.3.6.9 Signalling Carriage Mechanism failure

The TPs in this subclause refer to ETS 300 172 [1], subclause 9.2.9

SP158

Ensure that the IUT in any state except 0 or 10, on receiving a DL_RELEASE_INDICATION primitive from the SCM, enters state 0 (reference ETS 300 172 [1], subclause 9.2.9).

PSS1_BC/PC/IO/PV/CE/ TC0410IA

- Ensure that the IUT in state 3, on receiving a DL_RELEASE_INDICATION primitive from the SCM, enters state 0 (reference ETS 300 172 [1], subclause 9.2.9).

PSS1_BC/PC/IO/PV/CE/ TC0410IB

- Ensure that the IUT in state 8, on receiving a DL_RELEASE_INDICATION primitive from the SCM, enters state 0 (reference ETS 300 172 [1], subclause 9.2.9).

PSS1_BC/PC/IO/SE/CE/ TC0400HX

- Ensure that the IUT in state 2, on receiving a DL_RELEASE_INDICATION primitive from the SCM, enters state 0 (reference ETS 300 172 [1], subclause 9.2.9).

PSS1_BC/PC/IO/SE/CE/ TC0400HY

- Ensure that the IUT in state 25, on receiving a DL_RELEASE_INDICATION primitive from the SCM, enters state 0 (reference ETS 300 172 [1], subclause 9.2.9).

SP159

- Ensure that the IUT in state 10 on receiving a DL_RELEASE_INDICATION primitive from the SCM, starts T309 (reference ETS 300 172 [1], subclause 9.2.9).

NOTE: This STP is referenced in 'Untestable TPs' section in the associated ATS specification document.

SP160

- Ensure that the IUT in state 10, after SCM malfunction, on receiving a DL_ESTABLISH_CONFIRMATION primitive from the SCM, either sends a STATUS message containing a Cause IE, or sends a STATUS ENQUIRY message, and stops T309 (reference ETS 300 172 [1], subclause 9.2.9).

PSS1_BC/PC/IO/PV/CE/ TC0410IC

- Ensure that the IUT in state 10, after SCM malfunction, on receiving a DL_ESTABLISH_CONFIRMATION primitive from the SCM, either sends a STATUS message containing a Cause IE, or sends a STATUS ENQUIRY message (reference ETS 300 172 [1], subclause 9.2.9).

SP161

- Ensure that the IUT in state 10, on expiry of timer T309, enters state 0 (reference ETS 300 172 [1], subclause 9.2.9).

NOTE: This STP is referenced in 'Untestable TPs' section in the associated ATS specification document.

SP300

- Ensure that the IUT in any state, on receiving a DL-RELEASE-INDICATION primitive from the SCM, requests re-establishment by issuing a DL-ESTABLISH-REQUEST primitive (reference ETS 300 172 [1], subclause 9.2.9).

PSS1_BC/PC/IO/PV/CE/ TC0410YA

- Ensure that the IUT in state 1, on receiving a DL-RELEASE-INDICATION primitive from the SCM, requests re-establishment by issuing a DL-ESTABLISH-REQUEST primitive (reference ETS 300 172 [1], subclause 9.2.9).

PSS1_BC/PC/IO/PV/CE/ TC0410YB

- Ensure that the IUT in state 10, on receiving a DL-RELEASE-INDICATION primitive from the SCM, requests re-establishment by issuing a DL-ESTABLISH-REQUEST primitive (reference ETS 300 172 [1], subclause 9.2.9).

PSS1_BC/PC/IO/PV/CE/ TC0410YC

- Ensure that the IUT in state 11, on receiving a DL-RELEASE-INDICATION primitive from the SCM, requests re-establishment by issuing a DL-ESTABLISH-REQUEST primitive (reference ETS 300 172 [1], subclause 9.2.9).

5.3.7 Originating PINX Call Control requirements

The TPs in this subclause refer to ETS 300 172 [1], subclause 10.5.1, ZB.2.3.1 and ZD.2.3.2

The TPs in this subclause are only applicable to an IUT if it is declared in the PICS that it is capable of functioning as an Originating PINX.

SP165

- Ensure that the IUT in state 0, without the Calling/Connected Line Identification Restriction supplementary service invoked, in order to initiate a call, sends a SETUP message containing a Calling Party Number IE with a Presentation Indicator value, if present, encoded as "presentation allowed", and enters state 1 (reference ETS 300 172 [1], subclause 10.5.1.c).

PSS1_BC/OI/CA/PV/CE/ TC1110AN

- Ensure that the IUT in state 0, in order to initiate a call, sends a SETUP message containing a Calling Party Number IE (reference ETS 300 172 [1], subclause 10.5.1.c).

PSS1_BC/OI/BV/PV/CE/ TC1210AO

- Ensure that the IUT in state 0, without the Calling/Connected Line Identification Restriction supplementary service invoked, in order to initiate a call, sends a SETUP message containing a Calling Party Number IE with a Presentation Indicator value, if present, encoded as "presentation allowed" (reference ETS 300 172 [1], subclause 10.5.1.c).

SP166

- Ensure that the IUT in state 0, in order to initiate a call, sends a SETUP message containing a Calling Party Subaddress IE, and enters state 1 (reference ETS 300 172 [1], subclause 10.5.1.d).

This STP and its derived TP are only applicable in circumstances where the IUT as an Originating PINX includes the Calling Party Subaddress IE.

PSS1_BC/OI/CA/PV/CE/ TC1110AP

- Ensure that the IUT in state 0, in order to initiate a call, sends a SETUP message containing a Calling Party Subaddress IE (reference ETS 300 172 [1], subclause 10.5.1.d).

SP167

- Ensure that the IUT in state 0, in order to initiate a call, sends a SETUP message containing a Called Party Subaddress IE, and enters state 1 (reference ETS 300 172 [1], subclause 10.5.1.e).

This STP and its derived TP are only applicable in circumstances where the IUT as an Originating PINX includes the Called Party Subaddress IE.

PSS1_BC/OI/CA/PV/CE/ TC1110AQ

- Ensure that the IUT in state 0, in order to initiate a call, sends a SETUP message containing a Called Party Subaddress IE (reference ETS 300 172 [1], subclause 10.5.1.e).

SP168

- Ensure that the IUT in state 0, in order to initiate a call, sends a SETUP message containing a Low Layer Compatibility IE, and enters state 1 (reference ETS 300 172 [1], subclause 10.5.1.f).

This STP and its derived TP are only applicable in circumstances where the IUT as an Originating PINX includes the Low layer compatibility IE.

PSS1_BC/OI/CA/PV/CE/ TC1110AR

- Ensure that the IUT in state 0, in order to initiate a call, sends a SETUP message containing a Low Layer Compatibility IE (reference ETS 300 172 [1], subclause 10.5.1.f).

SP169

- Ensure that the IUT in state 0, in order to initiate a call, sends a SETUP message containing a High Layer Compatibility IE, and enters state 1 (reference ETS 300 172 [1], subclause 10.5.1.g).

This STP and its derived TP are only applicable in circumstances where the IUT as an Originating PINX includes the High layer compatibility IE.

PSS1_BC/OI/CA/PV/CE/ TC1110AS

- Ensure that the IUT in state 0, in order to initiate a call, sends a SETUP message containing a High Layer Compatibility IE (reference ETS 300 172 [1], subclause 10.5.1.g).

SP170

- Ensure that the IUT in state 0, in order to initiate a call, sends a SETUP message containing a Transit Counter IE with a Transit Count value encoded as 0, and enters state 1 (reference ETS 300 172 [1], subclause ZB.2.3.1).

This STP and its derived TP are only applicable in circumstances where the IUT as an Originating PINX includes the Transit counter IE.

PSS1_BC/OI/CA/PV/CE/ TC1110AT

- Ensure that the IUT in state 0, in order to initiate a call, sends a SETUP message containing a Transit Counter IE with a Transit Count value encoded as 0 (reference ETS 300 172 [1], subclause ZB.2.3.1).

SP171

- Ensure that the IUT in state 0, in order to initiate a call, sends a SETUP message containing a Party Category IE, and enters state 1 (reference ETS 300 172 [1], subclause ZD.2.3.1).

This STP and its derived TP are only applicable in circumstances where the IUT as an Originating PINX includes the Party category IE.

PSS1_BC/OI/CA/PV/CE/ TC1110AU

- Ensure that the IUT in state 0, in order to initiate a call, sends a SETUP message containing a Party Category IE (reference ETS 300 172 [1], subclause ZD.2.3.1).

NOTE: The following subclauses in ETS 300 172 [1] concerning the specific call control requirements for Originating PINX do not generate any TP.

- 10.5.1 Transmission of SETUP
- b) Progress Indicator
- 10.5.2 Agreement of Information channel
- 10.5.3 Receipt of Progress Indicators
- 10.5.4 Receipt of ALERTING message
- 10.5.5 Receipt of CONNECT message
- 10.5.7 Receipt of an indication of Call Clearing

5.3.8 Terminating PINX Call Control requirements

The TPs in this subclause refer to ETS 300 172 [1], subclause 10.6.

The TPs in this subclause are only applicable to an IUT if it is declared in the PICS that it is capable of functioning as a Terminating PINX.

5.3.8.1 Call Establishment

The TPs in this subclause refer to ETS 300 172 [1], subclause 10.6.1 to 10.6.4, ZB.2.3.2 and ZD.2.3.2.

SP302

- Ensure that the IUT in state 0, on receiving a SETUP message containing a Called Party Number IE with a number related to a terminal directly attached to the IUT, sends a CALL PROCEEDING or SETUP ACK message and enters state 9 or 25 respectively (reference ETS 300 172 [1], subclause 10.6).

PSS1_BC/TE/BI/SE/CE/ TC2000JB

- Ensure that the IUT in state 0, on receiving a SETUP message containing a Called Party Number IE with a number related to a terminal directly attached to the IUT, sends a CALL PROCEEDING or SETUP ACK message and enters state 9 or 25 respectively (reference ETS 300 172 [1], subclause 10.6).

SP172

- Ensure that the IUT in state 0, on receiving a SETUP message containing a Transit Counter IE with a Transit Count value encoded as 31 (the maximum number allowed) and containing a Called Party Number IE with a number related to a terminal directly attached to the IUT, sends a CALL PROCEEDING or SETUP ACK message and enters state 9 or 25 respectively (reference ETS 300 172 [1], subclause ZB.2.3.2).

This STP and its derived TP is only applicable to IUTs which support the Transit counter functionality.

PSS1_BC/TE/BV/PV/CE/ TC2210JC

- Ensure that the IUT in state 0, on receiving a SETUP message, containing a Transit Counter IE with a Transit Count value encoded as 31 (the maximum number allowed) and containing a Called Party Number IE with a number related to a terminal directly attached to the IUT, sends a CALL PROCEEDING or SETUP ACK message (reference ETS 300 172 [1], subclause ZB.2.3.2).

SP173

- Ensure that the IUT in state 9, in order to indicate the category of called party, sends an ALERTING message containing a Party Category IE with a Party Category value encoded as stated in the PIXIT, and enters state 7 (reference ETS 300 172 [1], subclause ZD.2.3.2).

This STP and its derived TP are only applicable in circumstances where the IUT as a terminating PINX includes the Party category IE in the ALERTING message.

PSS1_BC/TE/BV/PV/CE/ TC2210JT

- Ensure that the IUT in state 9, in order to indicate the category of the called party, sends an ALERTING message containing a Party Category IE with a Party Category value encoded as stated in the PIXIT (reference ETS 300 172 [1], subclause ZD.2.3.2).

SP174

- Ensure that the IUT in state 7 or 9, in order to indicate that the call has been answered, without Calling/Connected Line Identification Restriction supplementary service being invoked, sends a CONNECT message containing a Connected Number IE with the Presentation Indicator, if present, encoded as "presentation allowed" (reference ETS 300 172 [1], subclause 10.6.4).

PSS1_BC/TE/BV/PV/CE/ TC2210KE

- Ensure that the IUT in state 7, in order to indicate that the call has been answered, without Calling/Connected Line Identification Restriction supplementary service being invoked, sends a CONNECT message containing a Connected Number IE with the Presentation Indicator, if present, encoded as "presentation allowed" (reference ETS 300 172 [1], subclause 10.6.4).

PSS1_BC/TE/BV/PV/CE/ TC2210XJ

- Ensure that the IUT in state 7, in order to indicate that the call has been answered, sends a CONNECT message containing a Connected Number IE (reference ETS 300 172 [1], subclause 10.6.4).

PSS1_BC/TE/BV/PV/CE/ TC2210XK

- Ensure that the IUT in state 9, in order to indicate that the call has been answered, sends a CONNECT message containing a Connected Number IE (reference ETS 300 172 [1], subclause 10.6.4).

SP175

- Ensure that the IUT in state 7 or 9, in order to indicate that the call has been answered, sends a CONNECT message containing a Connected Subaddress IE (reference ETS 300 172 [1], subclause 10.6.4).

This STP and its derived TPs are only applicable in circumstances where the IUT as a terminating PINX includes the Connected subaddress IE.

PSS1_BC/TE/BV/PV/CE/ TC2210KG

- Ensure that the IUT in state 7, in order to indicate that the call has been answered, sends a CONNECT message containing a Connected Subaddress IE (reference ETS 300 172 [1], subclause 10.6.4).

PSS1_BC/TE/BV/PV/CE/ TC2210KH

- Ensure that the IUT in state 9, in order to indicate that the call has been answered, sends a CONNECT message containing a Connected Subaddress IE (reference ETS 300 172 [1], subclause 10.6.4).

SP176

- Ensure that the IUT in state 7 or 9, in order to indicate that the call has been answered, sends a CONNECT message containing a Low Layer Compatibility IE (reference ETS 300 172 [1], subclause 10.6.4).

This STP and its derived TP are only applicable in circumstances where the IUT as a terminating PINX includes the Low layer compatibility IE.

PSS1_BC/TE/BV/PV/CE/ TC2210KI

- Ensure that the IUT in state 9, in order to indicate that the call has been answered, sends a CONNECT message containing a Low Layer Compatibility IE (reference ETS 300 172 [1], subclause 10.6.4).

PSS1_BC/TE/BV/PV/CE/ TC2210KJ

- Ensure that the IUT in state 7, in order to indicate that the call has been answered, sends a CONNECT message containing a Low Layer Compatibility IE (reference ETS 300 172 [1], subclause 10.6.4).

SP177

- Ensure that the IUT in state 7 or 9, in order to indicate that the call has been answered, sends a CONNECT message containing a Party Category IE (reference ETS 300 172 [1], subclause ZD.2.3.2).

This STP and its derived TP are only applicable in circumstances where the IUT as a terminating PINX includes the Party category IE in the CONNECT message.

PSS1_BC/TE/BV/PV/CE/ TC2210KK

- Ensure that the IUT in state 7, in order to indicate that the call has been answered, sends a CONNECT message containing a Party Category IE (reference ETS 300 172 [1], subclause ZD.2.3.2).

PSS1_BC/TE/BV/PV/CE/ TC2210KL

- Ensure that the IUT in state 9, in order to indicate that the call has been answered, sends a CONNECT message containing a Party Category IE (reference ETS 300 172 [1], subclause ZD.2.3.2).

5.3.8.2 Call Clearing initiated by the Terminating PINX

The TPs in this subclause refer to ETS 300 172 [1], subclause 10.6.5.

SP178

- Ensure that the IUT in state 7,9 or 25, after having sent a PROGRESS message containing a Progress Indicator IE with a Progress Description value encoded as CCITT 8, on expiry of a timer as stated in the PIXIT, sends a DISCONNECT message and enters state 11 (reference ETS 300 172 [1], subclause 10.6.5).

PSS1_BC/TE/BV/PV/CC/ TC2211KU

- Ensure that the IUT in state 7, after having sent a PROGRESS message containing a Progress Indicator IE with a Progress Description value encoded as CCITT 8 to indicate that tones or announcements associated with call clearing are being applied, on expiry of a timer as stated in the PIXIT, sends a DISCONNECT message and enters state 11 (reference ETS 300 172 [1], subclause 10.6.5).

PSS1_BC/TE/BV/PV/CC/ TC2211KW

- Ensure that the IUT in state 9, after having sent a PROGRESS message containing a Progress Indicator IE with a Progress Description value encoded as CCITT 8 to indicate that tones or announcements associated with call clearing are being applied, on expiry of a timer as stated in the PIXIT, sends a DISCONNECT message and enters state 11 (reference ETS 300 172 [1], subclause 10.6.5).

PSS1_BC/TE/BV/PV/CC/ TC2211KX

- Ensure that the IUT in state 25, after having sent a PROGRESS message containing a Progress Indicator IE with a Progress Description value encoded as CCITT 8 to indicate that tones or announcements associated with call clearing are being applied, on expiry of a timer as stated in the PIXIT, sends a DISCONNECT message and enters state 11 (reference ETS 300 172 [1], subclause 10.6.5).

NOTE: The following subclauses in ETS 300 172 [1] concerning the specific call control requirements for Terminating PINX do not generate any TP.

- 10.6.1 Receiving SETUP
 - a) Progress Indicator
 - b) Low Layer Compatibility, High Layer Compatibility, Called Party Subaddress
 - c) Calling Party Number, Calling Party Subaddress
- 10.6.6 Receiving an Indication of Call Clearing

5.3.9 Incoming Gateway PINX Call Control requirements

The TPs in this subclause refer to ETS 300 172 [1], subclauses 10.7, ZB.2.3.4, ZC.5 and ZD.2.4.1.

The TPs in this subclause are only applicable to an IUT if it is declared in the PICS that is capable of functioning as an Incoming Gateway PINX.

5.3.9.1 Call Establishment

The TPs in this subclause refer to ETS 300 172 [1], subclause 10.7.1 to 10.7.6 and ZC.5

SP308

- Ensure that the IUT in state 0, in order to relay a call, sends a SETUP message, and enters state 1 (reference ETS 300 172 [1], subclause 10.7.1.a).

PSS1_BC/IG/BI/SE/CE/ TC5000UA

- Ensure that the IUT in state 0, in order to relay a call, sends a SETUP message, and enters state 1 (reference ETS 300 172 [1], subclause 10.7.1.a).

SP179

- Ensure that the IUT in state 0, in order to relay a call, sends a SETUP message containing a Sending Complete IE, and enters state 1 (reference ETS 300 172 [1], subclause 10.7.1.a).

This STP and its derived TP are only applicable in circumstances where the IUT as an Incoming gateway PINX includes the Sending Complete IE.

PSS1_BC/IG/BV/SE/CE/ TC5200UB

- Ensure that the IUT in state 0, in order to relay a call, sends a SETUP message containing a Sending Complete IE (reference ETS 300 172 [1], subclause 10.7.1.a).

SP180

- Ensure that the IUT in state 0, in order to relay a call, sends a SETUP message containing a Calling Party Number IE with one of the following combinations:

- 1) a number present and a Presentation Indicator value encoded as "presentation restricted"
- 2) a number present and a Presentation Indicator value encoded as "presentation allowed"
- 3) a number present and octet 3a omitted
- 4) a number omitted and a Presentation Indicator value encoded as "presentation restricted"
- 5) a number omitted and a Presentation Indicator value encoded as "number not available due to interworking"

and enters state 1 (reference ETS 300 172 [1], subclause 10.7.1.c).

PSS1_BC/IG/BV/PV/CE/ TC5210UC

- Ensure that the IUT in state 0, in order to relay a call, sends a SETUP message containing a Calling Party Number IE with one of the following combinations :

- 1) a number present and a Presentation Indicator value encoded as "presentation restricted"
- 2) a number present and a Presentation Indicator value encoded as "presentation allowed"
- 3) a number present and octet 3a omitted
- 4) a number omitted and a Presentation Indicator value encoded as "presentation restricted"
- 5) a number omitted and a Presentation Indicator value encoded as "number not available due to interworking"

(reference ETS 300 172 [1], subclause 10.7.1.c).

SP181

- Ensure that the IUT in state 0, in order to relay a call, sends a SETUP message containing a Calling Party Subaddress IE, and enters state 1 (reference ETS 300 172 [1], subclause 10.7.1.d).

This STP and its derived TP are only applicable in circumstances where the IUT as an Incoming gateway PINX includes the Calling Party Subaddress IE.

PSS1_BC/IG/BV/PV/CE/ TC5210UD

- Ensure that the IUT in state 0, in order to relay a call, sends a SETUP message containing a Calling Party Subaddress IE (reference ETS 300 172 [1], subclause 10.7.1.d).

SP182

- Ensure that the IUT in state 0, in order to relay a call, sends a SETUP message containing a Called Party Subaddress IE, and enters state 1 (reference ETS 300 172 [1], subclause 10.7.1.e).

This STP and its derived TP are only applicable in circumstances where the IUT as an Incoming gateway PINX includes the Called Party Subaddress IE.

PSS1_BC/IG/BV/PV/CE/ TC5210UE

- Ensure that the IUT in state 0, in order to relay a call, sends a SETUP message containing a Called Party Subaddress IE (reference ETS 300 172 [1], subclause 10.7.1.e).

SP183

- Ensure that the IUT in state 0, in order to relay a call, sends a SETUP message containing a Low Layer Compatibility IE, and enters state 1 (reference ETS 300 172 [1], subclause 10.7.1.f).

This STP and its derived TP are only applicable in circumstances where the IUT as an Incoming gateway PINX includes the Low layer compatibility IE.

PSS1_BC/IG/BV/PV/CE/ TC5210UF

- Ensure that the IUT in state 0, in order to relay a call, sends a SETUP message containing a Low Layer Compatibility IE (reference ETS 300 172 [1], subclause 10.7.1.f).

SP184

- Ensure that the IUT in state 0, in order to relay a call, sends a SETUP message containing a High Layer Compatibility IE, and enters state 1 (reference ETS 300 172 [1], subclause 10.7.1.g).

This STP and its derived TP are only applicable in circumstances where the IUT as an Incoming gateway PINX includes the High Layer Compatibility IE.

PSS1_BC/IG/BV/PV/CE/ TC5210UG

- Ensure that the IUT in state 0, in order to relay a call, sends a SETUP message containing a High Layer Compatibility IE (reference ETS 300 172 [1], subclause 10.7.1.g).

SP185

- Ensure that the IUT in state 0, in order to relay a call, sends a SETUP message containing a Transit Counter IE with a Transit Count value, and enters state 1 (reference ETS 300 172 [1], subclause ZB.2.3.4).

This STP and its derived TP are only applicable in circumstances where the IUT as an Incoming gateway PINX includes the Transit Counter IE.

PSS1_BC/IG/BV/PV/CE/ TC5210UH

- Ensure that the IUT in state 0, in order to relay a call, sends a SETUP message containing a Transit Counter IE with a Transit Count value (reference ETS 300 172 [1], subclause ZB.2.3.4).

SP186

- Ensure that the IUT in state 0, in order to relay a call, sends a SETUP message containing a Party Category IE, and enters state 1 (reference ETS 300 172 [1], subclause ZD.2.4.1).

This STP and its derived TP are only applicable in circumstances where the IUT as an Incoming gateway PINX includes the Party Category IE.

PSS1_BC/IG/BV/PV/CE/ TC5210UI

- Ensure that the IUT in state 0, in order to relay a call, sends a SETUP message containing a Party Category IE (reference ETS 300 172 [1], subclause ZD.2.4.1).

SP187

- Ensure that the IUT in state 0, in order to relay a call, sends a SETUP message containing zero or more Progress Indicator IE(s) with Progress Description values encoded as follows:
 - if any of Progress descriptions CCITT 1, CCITT 3 or ISO/IEC 16 are present then they are in a combination indicated in one of the columns of table 3;
 - not more than one of progress descriptions ISO/IEC 17, ISO/IEC 18 or ISO/IEC 19 is present; and
 - no other progress description is present.
 and enters state 1.(reference ETS 300 172 [1], subclause 10.7.2 and ZC.5).

Table 3

CCITT 1		1		1		1
CCITT 3					3	3
ISO/IEC 16			16	16	16	16

PSS1_BC/IG/BV/PV/CE/ TC5210UJ

- Ensure that the IUT in state 0, in order to relay a call, sends a SETUP message containing zero or more Progress Indicator IE(s) with Progress Description values encoded as follows:
 - if any of Progress descriptions CCITT 1, CCITT 3 or ISO/IEC 16 are present then they are in a combination indicated in one of the columns of table 3;
 - not more than one of progress descriptions ISO/IEC 17, ISO/IEC 18 or ISO/IEC 19 is present; and

- no other progress description is present.
 and enters state 1(reference ETS 300 172 [1], subclause 10.7.2 and ZC.5).

NOTE: The following subclauses in ETS 300 172 [1], concerning the specific call control requirements for Incoming Gateway PINX, do not generate any TP.

- 8.9.1 Transmission of SETUP message
 - b) Progress Indicator (cf. 8.9.2)
- 8.9.3 Agreement of the Information channel
- 8.9.4 Receiving Progress Indicators
- 8.9.5 Receiving ALERTING message
- 8.9.6 Receiving CONNECT message
- 8.9.7 Call Clearing initiated by the Incoming Gateway PINX
- 8.9.8 Receiving an indication of Call Clearing

5.3.10 Outgoing Gateway PINX Call Control requirements

The TPs in this subclause are only applicable to an IUT if it is declared in the PICS that it is capable of functioning as an Outgoing Gateway PINX.

The TPs in this subclause refer to ETS 300 172 [1], subclause 10.8 and ZC.6

5.3.10.1 Call Establishment

The TPs in this subclause refer to ETS 300 172 [1], subclauses 10.8.1 to 10.8.5 and ZC.6

SP188

- Ensure that the IUT in state 0, on receiving a SETUP message containing a Transit Counter IE with a Transit Count value encoded as 31 (the maximum number allowed) and containing a Called Party Number IE with a number which the IUT will route to another network, sends a CALL PROCEEDING or SETUP ACK message and enters state 9 or 25 respectively (reference ETS 300 172 [1], subclause ZB.2.3.5).

NOTE: No TP had been derived from this STP because of an identified problem with the base standard which does not allow for interworking with another network supporting Transit Counter or equivalent.

SP189

- Ensure that the IUT in state 9 or 25, after having sent a CALL PROCEEDING or SETUP ACK message, sends a PROGRESS or ALERTING or CONNECT message, or a combination of them, containing zero or more Progress Indicator IE(s), with no more than three Progress Indicator IEs in any one message, with Progress Description values encoded as follows:
 - if any of Progress indicators CCITT 1,2,4 or 8 or ISO/IEC 16 are present then they are in a combination indicated in one of the columns of table 4 ;
 - not more than one of progress descriptions ISO/IEC 17, ISO/IEC 18 or ISO/IEC 19 is present; and
 - no other progress description is present.
 (reference ETS 300 172 [1], subclauses 10.8.3 and ZC.6).

Table 4

CCITT 1		1		1		1		1		1		1		1		1			
CCITT 2				2	2			2	2			2	2			2	2		
CCITT 4								4	4	4	4					4	4	4	4
CCITT 8												8	8	8	8	8	8	8	8
ISO/IEC 16				16	16	16	16	16	16	16	16	16	16	16	16	16	16	16	16

PSS1_BC/OG/BV/PV/CE/ TC4210VB

- Ensure that the IUT in state 9, after having sent a CALL PROCEEDING message, sends a PROGRESS or ALERTING or CONNECT message, or a combination of them, containing zero or more Progress Indicator IE(s) with Progress Description values encoded as follows:
 - if any of Progress indicators CCITT 1,2,4 or 8 or ISO/IEC 16 are present then they are in a combination indicated in one of the columns of table 4;

- not more than one of progress descriptions ISO/IEC 17, ISO/IEC 18 or ISO/IEC 19 is present; and
 - no other progress description is present.
- (reference ETS 300 172 [1], subclauses 10.8.3 and ZC.6).

PSS1_BC/OG/BV/PV/CE/ TC4210EA

- Ensure that the IUT in state 25, after having sent a SETUP ACK message, sends a PROGRESS or ALERTING or CONNECT message, or a combination of them, containing zero or more Progress Indicator IE(s) with Progress Description values encoded as follows:
 - if any of Progress indicators CCITT 1,2,4 or 8 or ISO/IEC 16 are present then they are in a combination indicated in one of the columns of table 4;
 - not more than one of progress descriptions ISO/IEC 17, ISO/IEC 18 or ISO/IEC 19 is present; and
 - no other progress description is present.
- (reference ETS 300 172 [1], subclauses 10.8.3 and ZC.6).

SP190

- Ensure that the IUT in state 9, in order to indicate that the user is alerting, sends an ALERTING message and enters state 7 (reference ETS 300 172 [1], subclause 10.8.4).

PSS1_BC/OG/BV/SE/CE/ TC4200VC

- Ensure that the IUT in state 9, in order to indicate that the user is alerting, sends an ALERTING message (reference ETS 300 172 [1], subclause 10.8.4).

SP191

- Ensure that the IUT in state 9, in order to indicate the category of the called user, sends an ALERTING message containing a Party Category IE with a Party Category value encoded as stated in the PIXIT, and enters state 7 (reference ETS 300 172 [1], subclause 10.8.4).

PSS1_BC/OG/BV/PV/CE/ TC4210VD

- Ensure that the IUT in state 9, in order to indicate the category of the called user, sends an ALERTING message containing a Party Category IE with a Party Category value encoded as stated in the PIXIT (reference ETS 300 172 [1], subclause 10.8.4).

NOTE: The following subclauses in the ETS 300 172 [1] concerning the specific call control requirements for Outgoing Gateway PINX do not generate any TP.

- 10.8.1 Receipt of SETUP message
- a) Progress Indicator
 - b) Low Layer Compatibility, High Layer Compatibility, Calling Party Subaddress, Called Party Subaddress
 - c) Calling Party Number

5.3.11 Call Control requirements for a Transit PINX

The TPs in this subclause refer to ETS 300 172 [1], subclause 10.4

The TPs in this subclause are only applicable to an IUT if it is declared in the PICS that it is capable of functioning as a Transit PINX.

NOTE: All the Transit TPs take place where the IUT is relaying a call from the interface X to the interface Y.

5.3.11.1 Call Establishment

The TPs in this subclause refer to ETS 300 172 [1], subclauses 10.4.1 to 10.4.9, ZB.2.3.3, ZC.4 and ZD.2.3.3.

SP303

- Ensure that the IUT in transit state TCC_Idle, on receiving a SETUP message on interface X containing a Called Party Number IE with sufficient address information to route the call on interface Y, sends a CALL PROCEEDING or SETUP ACK message on interface X and sends a SETUP message on interface Y (reference ETS 300 172 [1], subclause 10.4.1).

PSS1_BC/TR/BI/SE/CE/ TC3000LA

- Ensure that the IUT in transit state TCC_Idle, on receiving a SETUP message on interface X containing a Called Party Number IE with sufficient address information to route the call on interface Y, sends a SETUP message on interface Y (reference ETS 300 172 [1], subclause 10.4.1).

SP192

- Ensure that the IUT in transit state TCC_Idle, on receiving a SETUP message on interface X containing a Called Party Number IE with sufficient address information to route the call on interface Y and a Transit Counter IE with a Transit Count value encoded as 0, sends a CALL PROCEEDING or SETUP ACK message on interface X and sends a SETUP message on interface Y containing a Transit Counter IE with a Transit Count value encoded as 1 (reference ETS 300 172 [1], subclause ZB.2.3.3.1).

This STP and its derived TP are only applicable to an IUT if it supports the Transit Counter functionality.

PSS1_BC/TR/BV/PV/CE/ TC3210LB

- Ensure that the IUT in transit state TCC_Idle, on receiving a SETUP message on interface X containing a Called Party Number IE with sufficient address information to route the call on interface Y and a Transit Counter IE with a Transit Count value encoded as 0, sends a SETUP message on interface Y containing a Transit Counter IE with a Transit Count value encoded as 1 (reference ETS 300 172 [1], subclause ZB.2.3.3.1).

SP193

- Ensure that the IUT in transit state TCC_Idle, on receiving a SETUP message on interface X containing a Called Party Number IE with sufficient address information to route the call on interface Y and a Transit Counter IE with a Transit Count value encoded as equal to the acceptable limit, either sends a RELEASE COMPLETE message on interface X, and returns to state 0 for the call on interface X, or sends a CALL PROCEEDING message followed by a DISCONNECT message on interface X and enters state 11 for the call on interface X, or sends a SETUP ACK message followed by a DISCONNECT message on interface X and enters state 11 for the call on interface X (reference ETS 300 172 [1], subclause ZB.2.3.3.2).

This STP and its derived TP are only applicable to an IUT if it supports the Transit Counter functionality.

PSS1_BC/TR/BV/PV/CE/ TC3210LC

- Ensure that the IUT in transit state TCC_Idle, on receiving a SETUP message on interface X containing a Called Party Number IE with sufficient address information to route the call on interface Y and a Transit Counter IE with a Transit Count value encoded as equal to the acceptable limit, either sends a RELEASE COMPLETE message on interface X, and enters state 0, or sends a CALL PROCEEDING message followed by a DISCONNECT message on interface X and enters state 11, or sends a SETUP ACK message followed by a DISCONNECT message on interface X and enters state 11 (reference ETS 300 172 [1], subclause ZB.2.3.3.2).

SP194

- Ensure that the IUT in transit state TCC_Idle, on receiving a SETUP message on interface X containing a Called Party Number IE with sufficient address information to route the call to interface Y and not containing a Transit Counter IE, sends a CALL PROCEEDING or SETUP ACK message on interface X and sends a SETUP message on interface Y containing a Transit Counter IE with a Transit Count value encoded with a value not less than 1 (reference ETS 300 172 [1], subclause ZB.2.3.3.1).

This STP and its derived TP are only applicable to an IUT if it supports the Transit Counter functionality.

PSS1_BC/TR/BV/PV/CE/ TC3210LD

- Ensure that the IUT in transit state TCC_Idle, on receiving a SETUP message on interface X containing a Called Party Number IE with sufficient address information to route the call on interface Y and not containing a Transit Counter IE, sends a SETUP message on interface Y containing a Transit Counter IE with a Transit Count value encoded as with a value not less than 1 (reference ETS 300 172 [1], subclause ZB.2.3.3.1).

SP195

- Ensure that the IUT in transit state TCC_AwaitDigits, in state 25 for the call on interface X, on receiving an INFORMATION message on interface X containing a Called Party Number IE with sufficient address information to route the call on interface Y, but not to determine that the number is complete, sends a SETUP message on interface Y and enters state 1 for the call on interface Y (reference ETS 300 172 [1], subclause 10.4.2).

PSS1_BC/TR/BV/PV/CE/ TC3210LE

- Ensure that the IUT in transit state TCC_AwaitDigits, in state 25 for the call on interface X, on receiving an INFORMATION message on interface X containing a Called Party Number IE with sufficient address information to route the call on interface Y, but not to determine that the number is complete, sends a SETUP message on interface Y (reference ETS 300 172 [1], subclause 10.4.2).

SP196

- Ensure that the IUT in transit state TCC_AwaitDigits, in state 25 for the call on interface X, on receiving an INFORMATION message on interface X containing a Called Party Number IE with sufficient address information to route the call on interface Y, and to determine that the number is complete, sends a SETUP message on interface Y, sends a CALL PROCEEDING message on interface X, enters state 9 for the call on interface X and enters state 1 for the call on interface Y (reference ETS 300 172 [1], subclause 10.4.2).

PSS1_BC/TR/BV/PV/CE/ TC3210LF

- Ensure that the IUT in transit state TCC_AwaitDigits, in state 25 for the call on interface X, on receiving an INFORMATION message on interface X containing a Called Party Number IE with sufficient address information to route the call on interface Y, and to determine that the number is complete, sends a SETUP message on interface Y, and sends a CALL PROCEEDING message on interface X (reference ETS 300 172 [1], subclause 10.4.2).

SP197

- Ensure that the IUT in transit state TCC_AwaitAdditionalDigits, in state 25 for the call on interface X, and in state 1 for the call on interface Y, after having received a SETUP message on interface X containing a Called Party Number IE with sufficient address information to route the call on interface Y but insufficient to determine that the number is complete, on receiving an INFORMATION message on interface X containing a Called Party Number IE with insufficient address information to determine that the number is complete, remains in the same states for the calls on interface X and Y (reference ETS 300 172 [1], subclause 10.4.3).

PSS1_BC/TR/BV/SE/CE/ TC3200LH

- Ensure that the IUT in transit state TCC_AwaitAdditionalDigits, in state 25 for the call on interface X, and in state 1 for the call on interface Y, after having received a SETUP message on interface X containing a Called Party Number IE with sufficient address information to route the call on interface Y but insufficient to determine that the number is complete, on receiving an INFORMATION message on interface X containing a Called Party Number IE with insufficient address information to determine that the number is complete, remains in the same states for the calls on interface X and Y (reference ETS 300 172 [1], subclause 10.4.3).

SP198

- Ensure that the IUT in transit state TCC_AwaitAdditionalDigits, in state 25 for the call on interface X, after having received a SETUP message on interface X containing a Called Party Number IE with sufficient address information to route the call on interface Y, on receiving an INFORMATION message on interface X containing a Called Party Number IE with sufficient address information to determine that the number is complete, sends a CALL PROCEEDING message on interface X, enters state 9 for the call on interface X and remains in state 1 for the call on interface Y (reference ETS 300 172 [1], subclause 10.4.3).

PSS1_BC/TR/BV/PV/CE/ TC3210LI

- Ensure that the IUT in transit state TCC_AwaitAdditionalDigits, in state 25 for the call on interface X, after having received a SETUP message on interface X containing a Called Party Number IE with sufficient address information to route the call on interface Y but insufficient to determine that the number is complete, on receiving an INFORMATION message on interface X containing a Called Party Number IE with sufficient address information to determine that the number is complete, sends a CALL PROCEEDING message on interface X and remains in state 1 for the call on interface Y (reference ETS 300 172 [1], subclause 10.4.3).

SP199

- Ensure that the IUT in transit state TCC_AwaitAdditionalDigits, in state 25 for the call on interface X, after having received a SETUP message on interface X containing a Called Party Number IE with sufficient address information to route the call on interface Y, on receiving a SETUP ACKNOWLEDGE message on interface Y containing a Channel Identification IE accepting the channel identified in the SETUP message, enters state 2 for the call on interface Y and remains in state 25 for the call on interface X (reference ETS 300 172 [1], subclause 10.4.3).

PSS1_BC/TR/BV/SE/CE/ TC3200LJ

- Ensure that the IUT in transit state TCC_AwaitAdditionalDigits, in state 25 for the call on interface X, after having received a SETUP message on interface X containing a Called Party Number IE with sufficient address information to route the call on interface Y but insufficient to determine that the number is complete, on receiving a SETUP ACKNOWLEDGE message on interface Y containing a Channel Identification IE accepting the channel identified in the SETUP message, enters state 2 for the call on interface Y and remains in state 25 for the call on interface X (reference ETS 300 172 [1], subclause 10.4.3).

SP200

- Ensure that the IUT in transit state TCC_AwaitAdditionalDigits after having received a SETUP message on interface X containing a Called Party Number IE with sufficient address information to route the call on interface Y, followed by an INFORMATION message containing a Called Party Number IE with insufficient information to determine that the number is complete, on receiving a SETUP ACKNOWLEDGE message on interface Y containing a Channel Identification IE accepting the channel identified in the SETUP message, sends an INFORMATION message on interface Y containing the same Called Party Number IE as in the INFORMATION message received on interface X and enters state 2 for the call on interface Y and remains in state 25 for the call on interface X (reference ETS 300 172 [1], subclause 10.4.3).

PSS1_BC/TR/BV/PV/CE/ TC3210LK

- Ensure that the IUT in transit state TCC_AwaitAdditionalDigits after having received a SETUP message on interface X containing a Called Party Number IE with sufficient address information to route the call on interface Y, followed by an INFORMATION message containing a Called Party Number IE with insufficient information to determine that the number is complete, on receiving a SETUP ACKNOWLEDGE message on interface Y containing a Channel Identification IE accepting the channel identified in the SETUP message, sends an INFORMATION message on interface Y containing the same addressing information as in the INFORMATION message received on interface X (reference ETS 300 172 [1], subclause 10.4.3).

SP201

- Ensure that the IUT in transit state TCC_AwaitAdditionalDigits, after having received a SETUP message on interface X containing a Called Party Number IE with sufficient address information to route the call on interface Y, followed by an INFORMATION message containing a Called Party Number IE with insufficient information to determine that the number is complete, on receiving a CALL PROCEEDING message on interface Y containing a Channel Identification IE accepting the channel identified in the SETUP message, does not send any INFORMATION messages on interface Y and enters state 3 for the call on interface Y (reference ETS 300 172 [1], subclause 10.4.3).

PSS1_BC/TR/BV/PV/CE/ TC3210LL

- Ensure that the IUT in transit state TCC_AwaitAdditionalDigits, after having received a SETUP message on interface X containing a Called Party Number IE with sufficient address information to route the call on interface Y, followed by an INFORMATION message containing a Called Party Number IE with insufficient information to determine that the number is complete, on receiving a CALL PROCEEDING message on interface Y containing a Channel Identification IE accepting the channel identified in the SETUP message, does not send any INFORMATION messages on interface Y (reference ETS 300 172 [1], subclause 10.4.3).

SP202

- Ensure that the IUT in transit state TCC_AwaitAdditionalDigits, after having received a SETUP message on interface X containing a Called Party Number IE with sufficient address information to route the call on interface Y, on receiving an ALERTING message on interface Y containing a Channel Identification IE accepting the channel identified in the SETUP message, sends an ALERTING message on interface X, enters state 4 for the call on interface Y and enters state 7 for the call on interface X (reference ETS 300 172 [1], subclause 10.4.3).

PSS1_BC/TR/BV/PV/CE/ TC3210LM

- Ensure that the IUT in transit state TCC_AwaitAdditionalDigits, after having received a SETUP message on interface X containing a Called Party Number IE with sufficient address information to route the call on interface Y, on receiving an ALERTING message on interface Y containing a Channel Identification IE accepting the channel identified in the SETUP message, sends an ALERTING message on interface X (reference ETS 300 172 [1], subclause 10.4.3).

SP203

- Ensure that the IUT in transit state TCC_AwaitAdditionalDigits, after having received a SETUP message on interface X containing a Called Party Number IE with sufficient address information to route the call on interface Y, on receiving a CONNECT message containing a Channel Identification IE accepting the channel identified in the SETUP message sent on interface Y, sends a CONNECT message on interface X, remains in state 8 or enters state 10 for the call on interface X, and enters state 10 for the call on interface Y (reference ETS 300 172 [1], subclause 10.4.3).

PSS1_BC/TR/BV/PV/CE/ TC3210RL

- Ensure that the IUT in transit state TCC_AwaitAdditionalDigits, after having received a SETUP message on interface X containing a Called Party Number IE with sufficient address information to route the call on interface Y, on receiving a CONNECT message containing a Channel Identification IE accepting the channel identified in the SETUP message, sends a CONNECT message on interface X (reference ETS 300 172 [1], subclause 10.4.3).

NOTE: A test case associated with this test purpose should allow for the IUT sending a CONNECT ACKNOWLEDGE on interface Y in response to the CONNECT message received.

SP204

- Ensure that the IUT in transit state TCC_Overlap, on receiving an INFORMATION message on interface X containing a Called Party Number IE with insufficient address information to determine that the number is complete, sends an INFORMATION message on interface Y containing a Called Party Number IE encoded as in the incoming INFORMATION message and remains in the same states (reference ETS 300 172 [1], subclause 10.4.4) .

PSS1_BC/TR/BV/PV/CE/ TC3210RM

- Ensure that the IUT in transit state TCC_Overlap, on receiving an INFORMATION message on interface X containing a Called Party Number IE with insufficient address information to determine that the number is complete, sends an INFORMATION message on interface Y containing a Called Party Number IE encoded as in the incoming INFORMATION message (reference ETS 300 172 [1], subclause 10.4.4) .

SP205

- Ensure that the IUT in transit state TCC_Overlap, on receiving a CALL PROCEEDING message on interface Y, sends a CALL PROCEEDING message on interface X, enters state 9 for the call on interface X, and enters state 3 for the call on interface Y (reference ETS 300 172 [1], subclause 10.4.4).

PSS1_BC/TR/BV/PV/CE/ TC3210LN

- Ensure that the IUT in transit state TCC_Overlap, on receiving a CALL PROCEEDING message on interface Y, sends a CALL PROCEEDING message on interface X (reference ETS 300 172 [1], subclause 10.4.4).

SP206

- Ensure that the IUT in transit state TCC_Overlap, on receiving an INFORMATION message on interface X containing a Sending Complete IE and a Called Party Number IE with sufficient address information to determine that the number is complete, sends a CALL PROCEEDING message on interface X, sends an INFORMATION message containing a Called Party Number IE encoded as that in the incoming INFORMATION message on interface Y, enters state 9 for the call on interface X and remains in state 2 for the call on interface Y (reference ETS 300 172 [1], subclause 10.4.4).

PSS1_BC/TR/BV/PV/CE/ TC3210LP

- Ensure that the IUT in transit state TCC_Overlap, on receiving an INFORMATION message on interface X containing a Sending Complete IE and a Called Party Number IE with sufficient address information to complete the called number, sends a CALL PROCEEDING message on interface X, and sends an INFORMATION message containing a Called Party Number IE encoded as that in the incoming INFORMATION message on interface Y (reference ETS 300 172 [1], subclause 10.4.4).

SP207

- Ensure that the IUT in transit state TCC_Overlap, on receiving an INFORMATION message on interface X containing a Called Party Number IE with sufficient address information to determine that the number is complete and not containing a Sending Complete IE, sends a CALL PROCEEDING message on interface X, sends an INFORMATION message containing a Called Party Number IE encoded as that in the incoming INFORMATION message on interface Y, enters state 9 for the call on interface X and remains in state 2 for the call on interface Y (reference ETS 300 172 [1], subclause 10.4.4).

PSS1_BC/TR/BV/PV/CE/ TC3210LG

- Ensure that the IUT in transit state TCC_Overlap, on receiving an INFORMATION message on interface X containing a Called Party Number IE with sufficient address information to determine that the number is complete and not containing a Sending Complete IE, sends a CALL PROCEEDING message on interface X, and sends an INFORMATION message containing a Called Party Number IE encoded as that in the incoming INFORMATION message on interface Y (reference ETS 300 172 [1], subclause 10.4.4).

SP208

- Ensure that the IUT in transit state TCC_Overlap, on receiving a PROGRESS message on interface Y, sends a PROGRESS message on interface X containing the same Progress Indicator IE(s) as in the incoming PROGRESS message and remains in the same states (reference ETS 300 172 [1], subclause 10.4.4s and ZC.4).

PSS1_BC/TR/BV/PV/CE/ TC3210LQ

- Ensure that the IUT in transit state TCC_Overlap, on receiving a PROGRESS message on interface Y, sends a PROGRESS message on interface X containing the same Progress Indicator IE(s) as in the incoming PROGRESS message on interface Y (reference ETS 300 172 [1], subclauses 10.4.4 and ZC.4).

SP209

- Ensure that the IUT in transit state TCC_Overlap, on receiving an ALERTING message on interface Y, sends an ALERTING message on interface X, enters state 7 for the call on interface X, and enters state 4 for the call on interface Y (reference ETS 300 172 [1], subclause 10.4.4).

PSS1_BC/TR/BV/PV/CE/ TC3210LR

- Ensure that the IUT in transit state TCC_Overlap, on receiving an ALERTING message on interface Y, sends an ALERTING message on interface X (reference ETS 300 172 [1], subclause 10.4.4).

SP210

- Ensure that the IUT in transit state TCC_Overlap, on receiving a CONNECT message on interface Y, sends a CONNECT message on interface X, enters state 8 or 10 for the call on interface X, and enters state 10 for the call on interface Y (reference ETS 300 172 [1], subclause 10.4.4).

PSS1_BC/TR/BV/PV/CE/ TC3210LS

- Ensure that the IUT in transit state TCC_Overlap, on receiving a CONNECT message on interface Y, sends a CONNECT message on interface X (reference ETS 300 172 [1], subclause 10.4.4).

NOTE: A test case associated with this test purpose should allow for the IUT sending a CONNECT ACKNOWLEDGE on interface Y in response to the CONNECT message received.

SP211

- Ensure that the IUT in transit state TCC_IncomingCallProceeding, on receiving a SETUP ACKNOWLEDGE message on interface Y containing a Channel Identification IE accepting the channel identified in the SETUP message, enters state 2 for the call on interface Y and remains in state 9 for the call on interface X (reference ETS 300 172 [1], subclause 10.4.6).

PSS1_BC/TR/BV/PV/CE/ TC3210LT

- Ensure that the IUT in transit state TCC_IncomingCallProceeding, on receiving a SETUP ACKNOWLEDGE message on interface Y containing a Channel Identification IE accepting the channel identified in the SETUP message, enters state 2 for the call on interface Y (reference ETS 300 172 [1], subclause 10.4.6).

SP212

- Ensure that the IUT in transit state TCC_IncomingCallProceeding, on receiving a CALL PROCEEDING message on interface Y containing a Channel Identification IE accepting the channel identified in the SETUP message, enters state 3 for the call on interface Y and remains in state 9 for the call on interface X (reference ETS 300 172 [1], subclause 10.4.6).

PSS1_BC/TR/BV/PV/CE/ TC3210LU

- Ensure that the IUT in transit state TCC_IncomingCallProceeding, on receiving a CALL PROCEEDING message on interface Y containing a Channel Identification IE accepting the channel identified in the SETUP message, enters state 3 for the call on interface Y (reference ETS 300 172 [1], subclause 10.4.6).

SP213

- Ensure that the IUT in transit state TCC_IncomingCallProceeding, on receiving an ALERTING message on interface Y containing a Channel Identification IE accepting the channel identified in the SETUP message, sends an ALERTING message on interface X, enters state 4 for the call on interface Y, and enters state 7 for the call on interface X (reference ETS 300 172 [1], subclause 10.4.6).

PSS1_BC/TR/BV/PV/CE/ TC3210LV

- Ensure that the IUT in transit state TCC_IncomingCallProceeding, on receiving an ALERTING message on interface Y containing a Channel Identification IE accepting the channel identified in the SETUP message, sends an ALERTING message on interface X (reference ETS 300 172 [1], subclause 10.4.6).

SP214

- Ensure that the IUT in transit state TCC_IncomingCallProceeding, on receiving a CONNECT message on interface Y containing a Channel Identification IE accepting the channel identified in the SETUP message, sends a CONNECT message on interface X, enters state 10 for the call on interface Y and enters state 8 or 10 for the call on interface X (reference ETS 300 172 [1], subclause 10.4.6).

PSS1_BC/TR/BV/PV/CE/ TC3210LW

- Ensure that the IUT in transit state TCC_IncomingCallProceeding, on receiving a CONNECT message on interface Y containing a Channel Identification IE accepting the channel identified in the SETUP message, sends a CONNECT message on interface X, enters state 10 for the call on interface Y and enters state 8 or 10 for the call on interface X (reference ETS 300 172 [1], subclause 10.4.6).

NOTE: A test case associated with this test purpose should allow for the IUT sending a CONNECT ACKNOWLEDGE on interface Y in response to the CONNECT message received.

SP215

- Ensure that the IUT in transit state TCC_TransitCallProceeding, in state 2 or 3 for the call on interface Y, on receiving a PROGRESS message on interface Y, sends a PROGRESS message on interface X containing Progress Indicator IEs encoded as in the incoming PROGRESS message on interface Y and remains in the same states (reference ETS 300 172 [1], subclause 10.4.7 and ZC.4).

PSS1_BC/TR/BV/PV/CE/ TC3210LX

- Ensure that the IUT in transit state TCC_TransitCallProceeding, in state 2 for the call on interface Y, on receiving a PROGRESS message on interface Y, sends a PROGRESS message on interface X containing Progress Indicator IEs encoded as in the incoming PROGRESS message on interface Y (reference ETS 300 172 [1], subclause 10.4.7 and ZC.4).

PSS1_BC/TR/BV/PV/CE/ TC3210LY

- Ensure that the IUT in transit state TCC_TransitCallProceeding, in state 3 for the call on interface Y, on receiving a PROGRESS message on interface Y, sends a PROGRESS message on interface X containing Progress Indicator IEs encoded as in the incoming PROGRESS message on interface Y (reference ETS 300 172 [1], subclause 10.4.7 and ZC.4).

SP216

- Ensure that the IUT in transit state TCC_TransitCallProceeding, in state 2 for the call on interface Y, on receiving a CALL PROCEEDING message on interface Y, remains in state 9 for the call on interface X and enters state 3 for the call on interface Y (reference ETS 300 172 [1], subclause 10.4.7).

PSS1_BC/TR/BV/PV/CE/ TC3210LZ

- Ensure that the IUT in transit state TCC_TransitCallProceeding, in state 2 for the call on interface Y, on receiving a CALL PROCEEDING message on interface Y, remains in state 9 for the call on interface X and enters state 3 for the call on interface Y (reference ETS 300 172 [1], subclause 10.4.7).

SP217

- Ensure that the IUT in transit state TCC_TransitCallProceeding, in state 2 or 3 for the call on interface Y, on receiving an INFORMATION message on interface X, remains in the same state for the call on interface Y, and does not send any INFORMATION message on interface Y (reference ETS 300 172 [1], subclause 10.4.7).

PSS1_BC/TR/BV/PV/CE/ TC3210MA

- Ensure that the IUT in transit state TCC_TransitCallProceeding, in state 2 for the call on interface Y, on receiving an INFORMATION message on interface X, remains in the same state for the call on interface Y, and does not send any INFORMATION message on interface Y (reference ETS 300 172 [1], subclause 10.4.7).

PSS1_BC/TR/BV/PV/CE/ TC3210MB

- Ensure that the IUT in transit state TCC_TransitCallProceeding, in state 3 for the call on interface Y, on receiving an INFORMATION message on interface X, remains in the same state for the call on interface Y, and does not send any INFORMATION message on interface Y (reference ETS 300 172 [1], subclause 10.4.7).

SP218

- Ensure that the IUT in transit state TCC_TransitCallProceeding, in state 2 or 3, for the call on interface Y, on receiving an ALERTING message on interface Y, sends an ALERTING message on interface X, enters state 7 on for the call on interface X and enters state 4 for the call on interface Y (reference ETS 300 172 [1], subclause 10.4.7).

PSS1_BC/TR/BV/PV/CE/ TC3210MC

- Ensure that the IUT in transit state TCC_TransitCallProceeding, in state 2 for the call on interface Y, on receiving an ALERTING message on interface Y, sends an ALERTING message on interface X (reference ETS 300 172 [1], subclause 10.4.7).

PSS1_BC/TR/BV/PV/CE/ TC3210MD

- Ensure that the IUT in transit state TCC_TransitCallProceeding, in state 3 for the call on interface Y, on receiving an ALERTING message on interface Y, sends an ALERTING message on interface X (reference ETS 300 172 [1], subclause 10.4.7).

SP219

- Ensure that the IUT in transit state TCC_TransitCallProceeding, in state 2 or 3 for the call on interface Y, on receiving a CONNECT message on interface Y, sends a CONNECT message on interface X, enters state 8 or 10 for the call on interface X and state 10 for the call on interface Y (reference ETS 300 172 [1], subclause 10.4.7).

PSS1_BC/TR/BV/PV/CE/ TC3210ME

- Ensure that the IUT in transit state TCC_TransitCallProceeding, in state 2 for the call on interface Y, on receiving a CONNECT message on interface Y, sends a CONNECT message on interface X (reference ETS 300 172 [1], subclause 10.4.7).

PSS1_BC/TR/BV/PV/CE/ TC3210MF

- Ensure that the IUT in transit state TCC_TransitCallProceeding, in state 3 for the call on interface Y, on receiving a CONNECT message on interface Y, sends a CONNECT message on interface X (reference ETS 300 172 [1], subclause 10.4.7).

NOTE: A test case associated with this test purpose should allow for the IUT sending a CONNECT ACKNOWLEDGE on interface Y in response to the CONNECT message received.

SP220

- Ensure that the IUT in transit state TCC_CallAlerting, on receiving a PROGRESS message on interface Y, sends a PROGRESS message on interface X containing Progress Indicator IEs encoded as in the incoming PROGRESS message on interface Y and remains in the same states (reference ETS 300 172 [1], subclause 10.4.8 and ZC.4).

PSS1_BC/TR/BV/PV/CE/ TC3210MG

- Ensure that the IUT in transit state TCC_CallAlerting, on receiving a PROGRESS message on interface Y, sends a PROGRESS message on interface X containing Progress Indicator IEs encoded as in the incoming PROGRESS message on interface Y (reference ETS 300 172 [1], subclause 10.4.8 and ZC.4).

SP221

- Ensure that the IUT in transit state TCC_CallAlerting, on receiving a CONNECT message on interface Y, sends a CONNECT message on interface X, enters state 8 or 10 for the call on interface X and state 10 for the call on interface Y (reference ETS 300 172 [1], subclause 10.4.8).

PSS1_BC/TR/BV/PV/CE/ TC3210MH

- Ensure that the IUT in transit state TCC_CallAlerting, on receiving a CONNECT message on interface Y, sends a CONNECT message on interface X (reference ETS 300 172 [1], subclause 10.4.8).

NOTE: A test case associated with this test purpose should allow for the IUT sending a CONNECT ACKNOWLEDGE on interface Y in response to the CONNECT message received.

SP222

- Ensure that the IUT in transit state TCC_CallActive, on receiving a PROGRESS message on interface Y, either sends a PROGRESS message on interface X containing Progress Indicator IEs encoded as in the incoming PROGRESS message on interface Y or discards the message and remains in the same states (reference ETS 300 172 [1], subclause 10.4.9 and ZC.4).

PSS1_BC/TR/BV/PV/CE/ TC3210MJ

- Ensure that the IUT in transit state TCC_CallActive, in state 10 for the call on interface X, on receiving a PROGRESS message on interface Y, either sends a PROGRESS message on interface X containing Progress Indicator IEs encoded as in the incoming PROGRESS message on interface Y or discards the message (reference ETS 300 172 [1], subclause 10.4.9 and ZC.4).

SP223

- Ensure that the IUT in transit state TCC_CallActive, on receiving a PROGRESS message on interface X, either sends a PROGRESS message on interface Y containing Progress Indicator IEs encoded as in the incoming PROGRESS message on interface X or discards the message and remains in the same states (reference ETS 300 172 [1], subclause 10.4.9 and ZC.4).

PSS1_BC/TR/BV/PV/CE/ TC3210ML

- Ensure that the IUT in transit state TCC_CallActive, in state 10 for the call on interface X, on receiving a PROGRESS message on interface X, either sends a PROGRESS message on interface Y containing Progress Indicator IEs encoded as in the incoming PROGRESS message on interface X or discards the message (reference ETS 300 172 [1], subclause 10.4.9 and ZC.4).

5.3.11.2 Call Clearing

The TPs in this subclause refer to ETS 300 172 [1], subclause 10.4.10

5.3.11.2.1 Call clearing not initiated by the transit PINX

The TPs in this subclause refer to ETS 300 172 [1], subclause 10.4.10.1.

i) Clearing initiated by preceding PINX

SP224

- Ensure that the IUT in transit state TCC_AwaitDigits, on receiving a DISCONNECT message on interface X, sends a RELEASE message on interface X and enters state 19 for the call on interface X (reference ETS 300 172 [1], subclause 10.4.10.1).

NOTE: No final test purpose has been derived because this super TP is covered by TC0201CR derived from SP060.

SP225

- Ensure that the IUT in transit state TCC_AwaitDigits, on receiving a RELEASE message on interface X, sends a RELEASE COMPLETE message on interface X and enters state 0 for the call on interface X (reference ETS 300 172 [1], subclause 10.4.10.1).

NOTE: No final test purpose has been derived because this super TP is covered by TC0401XS derived from SP131.

SP226

- Ensure that the IUT in transit state TCC_AwaitDigits, on receiving a RELEASE COMPLETE message on interface X, enters state 0 for the call on interface X (reference ETS 300 172 [1], subclause 10.4.10.1).

NOTE: No final test purpose has been derived because this super TP is covered by TC0401GK derived from SP132.

SP227

- Ensure that the IUT in transit state TCC_AwaitAdditionalDigits or TCC_IncomingCallProceeding, on receiving a DISCONNECT message on interface X, sends a RELEASE message on interface X, sends a DISCONNECT or RELEASE message on interface Y, enters state 19 for the call on interface X and enters state 11 or 19 for the call on interface Y (reference ETS 300 172 [1], subclause 10.4.10.1).

PSS1_BC/TR/BV/PV/CC/ TC3211NB

- Ensure that the IUT in transit state TCC_AwaitAdditionalDigits, on receiving a DISCONNECT message on interface X, sends a DISCONNECT or RELEASE message on interface Y (reference ETS 300 172 [1], subclause 10.4.10.1).

PSS1_BC/TR/BV/PV/CC/ TC3211NC

- Ensure that the IUT in transit state TCC_IncomingCallProceeding, on receiving a DISCONNECT message on interface X, sends a DISCONNECT or RELEASE message on interface Y (reference ETS 300 172 [1], subclause 10.4.10.1).

SP228

- Ensure that the IUT in transit state TCC_AwaitAdditionalDigits or TCC_IncomingCallProceeding, on receiving a RELEASE message on interface X, sends a RELEASE COMPLETE message on interface X, sends a DISCONNECT or RELEASE message on interface Y, enters state 0 for the call on interface X and enters state 11 or 19 for the call on interface Y (reference ETS 300 172 [1], subclause 10.4.10.1).

PSS1_BC/TR/BV/PV/CC/ TC3211ND

- Ensure that the IUT in transit state TCC_AwaitAdditionalDigits, on receiving a RELEASE message on interface X, sends a DISCONNECT or RELEASE message on interface Y (reference ETS 300 172 [1], subclause 10.4.10.1).

PSS1_BC/TR/BV/PV/CC/ TC3211NE

- Ensure that the IUT in transit state TCC_IncomingCallProceeding, on receiving a RELEASE message on interface X, sends a DISCONNECT or RELEASE message on interface Y (reference ETS 300 172 [1], subclause 10.4.10.1).

SP229

- Ensure that the IUT in transit state TCC_AwaitAdditionalDigits or TCC_IncomingCallProceeding, on receiving a RELEASE COMPLETE message on interface X, sends a DISCONNECT or RELEASE message on interface Y, enters state 0 for the call on interface X and enters state 11 or 19 for the call on interface Y (reference ETS 300 172 [1], subclause 10.4.10.1).

PSS1_BC/TR/BV/PV/CC/ TC3211NF

- Ensure that the IUT in transit state TCC_AwaitAdditionalDigits, on receiving a RELEASE COMPLETE message on interface X, sends a DISCONNECT or RELEASE message on interface Y (reference ETS 300 172 [1], subclause 10.4.10.1).

PSS1_BC/TR/BV/PV/CC/ TC3211NG

- Ensure that the IUT in transit state TCC_IncomingCallProceeding, on receiving a RELEASE COMPLETE message on interface X, sends a DISCONNECT or RELEASE message on interface Y (reference ETS 300 172 [1], subclause 10.4.10.1).

SP230

- Ensure that the IUT in transit state TCC_Overlap, TCC_TransitCallProceeding, TCC_CallAlerting or TCC_CallActive, on receiving a DISCONNECT message on interface X, sends a RELEASE message on interface X, sends a DISCONNECT message on interface Y, enters state 19 for the call on interface X and enters state 11 for the call on interface Y (reference ETS 300 172 [1], subclause 10.4.10.1).

PSS1_BC/TR/BV/PV/CC/ TC3211NH

- Ensure that the IUT in transit state TCC_Overlap, on receiving a DISCONNECT message on interface X, sends a DISCONNECT message on interface Y (reference ETS 300 172 [1], subclause 10.4.10.1).

PSS1_BC/TR/BV/PV/CC/ TC3211NI

- Ensure that the IUT in transit state TCC_TransitCallProceeding, on receiving a DISCONNECT message on interface X, sends a DISCONNECT message on interface Y (reference ETS 300 172 [1], subclause 10.4.10.1).

PSS1_BC/TR/BV/PV/CC/ TC3211NJ

- Ensure that the IUT in transit state TCC_CallAlerting, on receiving a DISCONNECT message on interface X, sends a DISCONNECT message on interface Y (reference ETS 300 172 [1], subclause 10.4.10.1).

PSS1_BC/TR/CA/PV/CC/ TC3111NK

- Ensure that the IUT in transit state TCC_CallActive, on receiving a DISCONNECT message on interface X, sends a DISCONNECT message on interface Y (reference ETS 300 172 [1], subclause 10.4.10.1).

SP231

- Ensure that the IUT in transit state TCC_Overlap, TCC_TransitCallProceeding, TCC_CallAlerting or TCC_CallActive, on receiving a RELEASE message on interface X, sends a RELEASE COMPLETE message on interface X, sends a DISCONNECT message on interface Y, enters state 0 for the call on interface X and enters state 11 for the call on interface Y (reference ETS 300 172 [1], subclause 10.4.10.1).

PSS1_BC/TR/BV/PV/CC/ TC3211NL

- Ensure that the IUT in transit state TCC_Overlap, on receiving a RELEASE message on interface X, sends a DISCONNECT message on interface Y (reference ETS 300 172 [1], subclause 10.4.10.1).

PSS1_BC/TR/BV/PV/CC/ TC3211NM

- Ensure that the IUT in transit state TCC_Transit Call Proceeding, on receiving a RELEASE message on interface X, sends a DISCONNECT message on interface Y (reference ETS 300 172 [1], subclause 10.4.10.1).

PSS1_BC/TR/BV/PV/CC/ TC3211NN

- Ensure that the IUT in transit state TCC_CallAlerting, on receiving a RELEASE message on interface X, sends a DISCONNECT message on interface Y (reference ETS 300 172 [1], subclause 10.4.10.1).

PSS1_BC/TR/BV/PV/CC/ TC3211NO

- Ensure that the IUT in transit state TCC_CallActive, on receiving a RELEASE message on interface X, sends a DISCONNECT message on interface Y (reference ETS 300 172 [1], subclause 10.4.10.1).

SP232

- Ensure that the IUT in transit state TCC_Overlap, TCC_TransitCallProceeding, TCC_CallAlerting or TCC_CallActive, on receiving a RELEASE COMPLETE message on interface X, sends a DISCONNECT message on interface Y, enters state 0 for the call on interface X and enters state 11 for the call on interface Y (reference ETS 300 172 [1], subclause 10.4.10.1).

PSS1_BC/TR/BV/PV/CC/ TC3211NP

- Ensure that the IUT in transit state TCC_Overlap, on receiving a RELEASE COMPLETE message on interface X, sends a DISCONNECT message on interface Y (reference ETS 300 172 [1], subclause 10.4.10.1).

PSS1_BC/TR/BV/PV/CC/ TC3211NQ

- Ensure that the IUT in transit state TCC_TransitCallProceeding, on receiving a RELEASE COMPLETE message on interface X, sends a DISCONNECT message on interface Y (reference ETS 300 172 [1], subclause 10.4.10.1).

PSS1_BC/TR/BV/PV/CC/ TC3211NR

- Ensure that the IUT in transit state TCC_CallAlerting, on receiving a RELEASE COMPLETE message on interface X, sends a DISCONNECT message on interface Y (reference ETS 300 172 [1], subclause 10.4.10.1).

PSS1_BC/TR/BV/PV/CC/ TC3211NS

- Ensure that the IUT in transit state TCC_CallActive, on receiving a RELEASE COMPLETE message on interface X, sends a DISCONNECT message on interface Y (reference ETS 300 172 [1], subclause 10.4.10.1).

SP233

- Ensure that the IUT in transit state TCC_AwaitOutgoingRelease, on receiving a RELEASE message on interface Y, sends a RELEASE COMPLETE message on interface Y and enters state 0 for the call on interface Y (reference ETS 300 172 [1], subclause 10.4.10.1).

NOTE: No final test purpose has been derived because this super TP is covered by TC0101CS derived from SP061.

SP234

- Ensure that the IUT in transit state TCC_AwaitOutgoingRelease, on receiving a RELEASE COMPLETE message on interface Y, enters state 0 for the call on interface Y (reference ETS 300 172 [1], subclause 10.4.10.1).

NOTE: No final test purpose has been derived because this super TP is covered by TC0401XT derived from SP132.

ii) Clearing initiated by subsequent PINX

SP235

- Ensure that the IUT in transit state TCC_CallAlerting or TCC_CallActive, on receiving a DISCONNECT message on interface Y, sends a DISCONNECT message on interface X, sends a RELEASE message on interface Y, enters state 11 for the call on interface X and enters state 19 for the call on interface Y (reference ETS 300 172 [1], subclause 10.4.10.1).

PSS1_BC/TR/BV/PV/CC/ TC3211NV

- Ensure that the IUT in transit state TCC_CallAlerting, on receiving a DISCONNECT message on interface Y, sends a DISCONNECT message on interface X (reference ETS 300 172 [1], subclause 10.4.10.1).

PSS1_BC/TR/CA/PV/CC/ TC3111NW

- Ensure that the IUT in transit state TCC_CallActive, on receiving a DISCONNECT message on interface Y, sends a DISCONNECT message on interface X (reference ETS 300 172 [1], subclause 10.4.10.1).

SP236

- Ensure that the IUT in transit state TCC_CallAlerting or TCC_CallActive, on receiving a RELEASE message on interface Y, sends a DISCONNECT message on interface X, sends a RELEASE COMPLETE message on interface Y, enters state 11 for the call on interface X and enters state 0 for the call on interface Y (reference ETS 300 172 [1], subclause 10.4.10.1).

PSS1_BC/TR/BV/PV/CC/ TC3211NX

- Ensure that the IUT in transit state TCC_CallAlerting, on receiving a RELEASE message on interface Y, sends a DISCONNECT message on interface X (reference ETS 300 172 [1], subclause 10.4.10.1).

PSS1_BC/TR/BV/PV/CC/ TC3211NY

- Ensure that the IUT in transit state TCC_CallActive, on receiving a RELEASE message on interface Y, sends a DISCONNECT message on interface X (reference ETS 300 172 [1], subclause 10.4.10.1).

SP237

- Ensure that the IUT in transit state TCC_CallAlerting or TCC_CallActive, on receiving a RELEASE COMPLETE message on interface Y, sends a DISCONNECT message on interface X, enters state 11 for the call on interface X and enters state 0 for the call on interface Y (reference ETS 300 172 [1], subclause 10.4.10.1).

PSS1_BC/TR/BV/PV/CC/ TC3211NZ

- Ensure that the IUT in transit state TCC_CallAlerting, on receiving a RELEASE COMPLETE message on interface Y, sends a DISCONNECT message on interface X (reference ETS 300 172 [1], subclause 10.4.10.1).

PSS1_BC/TR/BV/PV/CC/ TC3211OA

- Ensure that the IUT in transit state TCC_CallActive, on receiving a RELEASE COMPLETE message on interface Y, sends a DISCONNECT message on interface X (reference ETS 300 172 [1], subclause 10.4.10.1).

SP238

- Ensure that the IUT in transit state TCC_AwaitIncomingRelease, on receiving a RELEASE message on interface X, sends a RELEASE COMPLETE message on interface X and enters state 0 for the call on interface X (reference ETS 300 172 [1], subclause 10.4.10.1).

NOTE: No final test purpose has been derived because this super TP is covered by TC0101CS derived from SP061.

5.3.11.2.2 Call Clearing initiated by the Transit PINX

The TPs in this subclause refer to ETS 300 172 [1], subclause 10.4.10.2

SP239

- Ensure that the IUT in transit state TCC_AwaitDigits, TCC_AwaitAdditionalDigits, TCC_Overlap, TCC_IncomingCallProceeding, TCC_TransitCallProceeding, TCC_CallAlerting or TCC_CallActive, in order to indicate that in-band tones or announcements associated with call clearing are being applied on interface X, sends a PROGRESS message on interface X containing a Progress Indicator IE with the Progress Description value encoded as CCITT 8 and containing a Cause IE, and remains in the same state for the call on interface X. The behaviour on interface Y is not tested (reference ETS 300 172 [1], subclause 10.4.10.2).

PSS1_BC/TR/BV/PV/CE/ TC3210PY

- Ensure that the IUT in transit state TCC_AwaitDigits, in order to indicate that in-band tones or announcements associated with call clearing are being applied on interface X, sends a PROGRESS message on interface X containing a Progress Indicator IE with the Progress Description value encoded as CCITT 8 and containing a Cause IE. The behaviour on interface Y is not tested (reference ETS 300 172 [1], subclause 10.4.10.2).

PSS1_BC/TR/BV/PV/CE/ TC3210PZ

- Ensure that the IUT in transit state TCC_AwaitAdditionalDigits, in order to indicate that in-band tones or announcements associated with call clearing are being applied on interface X, sends a PROGRESS message on interface X containing a Progress Indicator IE with the Progress Description value encoded as CCITT 8 and containing a Cause IE. The behaviour on interface Y is not tested (reference ETS 300 172 [1], subclause 10.4.10.2).

PSS1_BC/TR/BV/PV/CE/ TC3210QA

- Ensure that the IUT in transit state TCC_Overlap, in order to indicate that in-band tones or announcements associated with call clearing are being applied on interface X, sends a PROGRESS message on interface X containing a Progress Indicator IE with the Progress Description value encoded as CCITT 8 and containing a Cause IE. The behaviour on interface Y is not tested (reference ETS 300 172 [1], subclause 10.4.10.2).

PSS1_BC/TR/BV/PV/CE/ TC3210QB

- Ensure that the IUT in transit state TCC_IncomingCallProceeding, in order to indicate that in-band tones or announcements associated with call clearing are being applied on interface X, sends a PROGRESS message on interface X containing a Progress Indicator IE with the Progress Description value encoded as CCITT 8 and containing a Cause IE. The behaviour on interface Y is not tested (reference ETS 300 172 [1], subclause 10.4.10.2).

PSS1_BC/TR/BV/PV/CE/ TC3210QC

- Ensure that the IUT in transit state TCC_TransitCallProceeding, in order to indicate that in-band tones or announcements associated with call clearing are being applied on interface X, sends a PROGRESS message on interface X containing a Progress Indicator IE with the Progress Description value encoded as CCITT 8 and containing a Cause IE. The behaviour on interface Y is not tested (reference ETS 300 172 [1], subclause 10.4.10.2).

PSS1_BC/TR/BV/PV/CE/ TC3210QD

- Ensure that the IUT in transit state TCC_CallAlerting, in order to indicate that in-band tones or announcements associated with call clearing are being applied on interface X, sends a PROGRESS message on interface X containing a Progress Indicator IE with the Progress Description value encoded as CCITT 8 and containing a Cause IE. The behaviour on interface Y is not tested (reference ETS 300 172 [1], subclause 10.4.10.2).

PSS1_BC/TR/BV/PV/CE/ TC3210QE

- Ensure that the IUT in transit state TCC_CallActive in order to indicate that in-band tones or announcements associated with call clearing are being applied on interface X, sends a PROGRESS message on interface X containing a Progress Indicator IE with the Progress Description value encoded as CCITT 8 and containing a Cause IE. The behaviour on interface Y is not tested (reference ETS 300 172 [1], subclause 10.4.10.2).

This TP is only applicable to an IUT if it sends a PROGRESS message in state TCC_CallActive to indicate tones and announcements.

SP240

- Ensure that the IUT, in transit state TCC_AwaitIncomingDisconnect, after having sent a PROGRESS message on interface X containing a Progress Indicator IE with a Progress Description value encoded as CCITT 8 to indicate that an in-band tone or announcement associated with call clearing is being applied, when the tone or announcement is complete or has been applied for sufficient time (i.e. on expiry of a timer provided in the PIXIT), sends a DISCONNECT message on interface X and enters state 11 for the call on interface X. The behaviour on interface Y is not tested (reference ETS 300 172 [1], subclause 10.4.10.2).

PSS1_BC/TR/BV/PV/CC/ TC3211OC

Ensure that the IUT, in transit state TCC_AwaitIncomingDisconnect, after having sent a PROGRESS message on interface X containing a Progress Indicator IE with a Progress Description value encoded as CCITT 8 to indicate that an in-band tone or announcement associated with call clearing is being applied, when the tone or announcement is complete or has been applied for sufficient time (i.e. on expiry of a timer provided in PIXIT), sends a DISCONNECT message on interface X, and enters state 11 for the call on interface X. The behaviour on interface Y is not tested (reference ETS 300 172 [1], subclause 10.4.10.2).

5.3.11.3 Handling of Basic Call IEs at a Transit PINX

The TPs in this subclause refer to ETS 300 172 [1], subclause 10.4.11.

SP241

- Ensure that the IUT in transit state TCC_Idle, on receiving a SETUP message on interface X containing a Called Party Number IE encoded with sufficient address information to route the call on interface Y, sends a SETUP message on interface Y containing a Called Party Number IE, sends a CALL PROCEEDING or SETUP ACKNOWLEDGE message on interface X, enters state 9 or 25 respectively for the call on interface X, and enters state 1 for the call on interface Y (reference ETS 300 172 [1], subclause 10.4.11.2).

PSS1_BC/TR/BV/PV/CE/ TC3210QI

- Ensure that the IUT in transit state TCC_Idle, on receiving a SETUP message on interface X containing a Called Party Number IE encoded with sufficient address information to route the call on interface Y, sends a SETUP message on interface Y containing a Called Party Number IE (reference ETS 300 172 [1], subclause 10.4.11.2).

SP242

- Ensure that the IUT in transit state TCC_Idle, on receiving a SETUP message on interface X containing a Called Party Number IE encoded with sufficient address information to route the call on interface Y and a Called Party Subaddress IE, sends a SETUP message on interface Y containing a Called Party Subaddress IE encoded as in the incoming SETUP message on interface X, sends a CALL PROCEEDING or SETUP ACKNOWLEDGE message on interface X, enters state 9 or 25 respectively for the call on interface X, and enters state 1 for the call on interface Y (reference ETS 300 172 [1], subclause 10.4.11.2).

PSS1_BC/TR/BV/PV/CE/ TC3210QJ

- Ensure that the IUT in transit state TCC_Idle, on receiving a SETUP message on interface X containing a Called Party Number IE encoded with sufficient address information to route the call on interface Y and a Called Party Subaddress IE, sends a SETUP message on interface Y containing a Called Party Subaddress IE encoded as in the incoming SETUP message on interface X (reference ETS 300 172 [1], subclause 10.4.11.2).

SP243

- Ensure that the IUT in transit state TCC_Idle, on receiving a SETUP message on interface X containing a Called Party Number IE encoded with sufficient address information to route the call on interface Y and a High Layer Compatibility IE, sends a SETUP message on interface Y containing a High Layer Compatibility IE encoded as in the incoming SETUP message on interface X, sends a CALL PROCEEDING or SETUP ACKNOWLEDGE message on interface X, enters state 9 or 25 respectively for the call on interface X, and enters state 1 for the call on interface Y (reference ETS 300 172 [1], subclause 10.4.11.2).

PSS1_BC/TR/BV/PV/CE/ TC3210QK

- Ensure that the IUT in transit state TCC_Idle, on receiving a SETUP message on interface X containing a Called Party Number IE encoded with sufficient address information to route the call on interface Y and a High Layer Compatibility IE, sends a SETUP message on interface Y containing a High Layer Compatibility IE encoded as in the incoming SETUP message on interface X (reference ETS 300 172 [1], subclause 10.4.11.2).

SP244

- Ensure that the IUT in transit state TCC_Idle, on receiving a SETUP message on interface X containing a Called Party Number IE encoded with sufficient address information to route the call on interface Y and a Low Layer Compatibility IE, sends a SETUP message on interface Y containing a Low Layer Compatibility IE encoded as in the incoming SETUP message on interface X, sends a CALL PROCEEDING or SETUP ACKNOWLEDGE message on interface X, enters state 9 or 25 respectively for the call on interface X, and enters state 1 for the call on interface Y (reference ETS 300 172 [1], subclause 10.4.11.2).

PSS1_BC/TR/BV/PV/CE/ TC3210QL

- Ensure that the IUT in transit state TCC_Idle, on receiving a SETUP message on interface X containing a Called Party Number IE encoded with sufficient address information to route the call on interface Y and a Low Layer Compatibility IE, sends a SETUP message on interface Y containing a Low Layer Compatibility IE encoded as in the incoming SETUP message on interface X (reference ETS 300 172 [1], subclause 10.4.11.2).

SP245

- Ensure that the IUT in transit state TCC_Idle, on receiving a SETUP message on interface X containing a Called Party Number IE encoded with sufficient address information to route the call on interface Y and a Party Category IE, sends a SETUP message on interface Y containing a Party Category IE encoded as in the incoming SETUP message on interface X, sends a CALL PROCEEDING or SETUP ACKNOWLEDGE message on interface X, enters state 9 or 25 respectively for the call on interface X, and enters state 1 for the call on interface Y (reference ETS 300 172 [1], subclause 10.4.11.2).

PSS1_BC/TR/BV/PV/CE/ TC3210OM

- Ensure that the IUT in transit state TCC_Idle, on receiving a SETUP message on interface X containing a Called Party Number IE encoded with sufficient address information to route the call on interface Y and a Party Category IE, sends a SETUP message on interface Y containing a Party Category IE encoded as in the incoming SETUP message on interface X (reference ETS 300 172 [1], subclause 10.4.11.2).

SP246

- Ensure that the IUT in transit state TCC_Idle, on receiving a SETUP message on interface X containing a Called Party Number IE encoded with sufficient address information to route the call on interface Y and a Calling Party Number IE, sends a SETUP message on interface Y containing a Calling Party Number IE, sends a CALL PROCEEDING or SETUP ACKNOWLEDGE message on interface X, enters state 9 or 25 respectively for the call on interface X, and enters state 1 for the call on interface Y (reference ETS 300 172 [1], subclause 10.4.11.2).

PSS1_BC/TR/BV/PV/CE/ TC3210ON

- Ensure that the IUT in transit state TCC_Idle, on receiving a SETUP message on interface X containing a Called Party Number IE encoded with sufficient address information to route the call on interface Y and a Calling Party Number IE, sends a SETUP message on interface Y containing a Calling Party Number IE (reference ETS 300 172 [1], subclause 10.4.11.2).

SP247

- Ensure that the IUT in transit state TCC_Idle, on receiving a SETUP message on interface X containing a Called Party Number IE encoded with sufficient address information to route the call on interface Y and a Calling Party Subaddress IE, sends a SETUP message on interface Y containing a Calling Party Subaddress IE encoded as in the incoming SETUP message on interface X, sends a CALL PROCEEDING or SETUP ACKNOWLEDGE message on interface X, enters state 9 or 25 respectively for the call on interface X, and enters state 1 for the call on interface Y (reference ETS 300 172 [1], subclause 10.4.11.2).

PSS1_BC/TR/BV/PV/CE/ TC3210OO

- Ensure that the IUT in transit state TCC_Idle, on receiving a SETUP message on interface X containing a Called Party Number IE encoded with sufficient address information to route the call on interface Y and a Calling Party Subaddress IE, sends a SETUP message on interface Y containing a Calling Party Subaddress IE encoded as in the incoming SETUP message on interface X (reference ETS 300 172 [1], subclause 10.4.11.2).

SP248

- Ensure that the IUT in transit state TCC_Idle, on receiving a SETUP message on interface X containing a Called Party Number IE encoded with sufficient address information to route the call on interface Y and a Progress Indicator IE, sends a SETUP message on interface Y containing a Progress Indicator IE encoded as in the incoming SETUP message on interface X, sends a CALL PROCEEDING or SETUP ACKNOWLEDGE message on interface X, enters state 9 or 25 respectively for the call on interface X, and enters state 1 for the call on interface Y (reference ETS 300 172 [1], subclause 10.4.11.2 and ZC.4).

PSS1_BC/TR/BV/PV/CE/ TC3210OP

- Ensure that the IUT in transit state TCC_Idle, on receiving a SETUP message on interface X containing a Called Party Number IE encoded with sufficient address information to route the call on interface Y and a Progress Indicator IE, sends a SETUP message on interface Y containing a Progress Indicator IE encoded as in the incoming SETUP message on interface X (reference ETS 300 172 [1], subclause 10.4.11.2 and ZC.4).

SP249

- Ensure that the IUT in transit state TCC_Overlap, TCC_TransitCallProceeding, TCC_CallActive or TCC_CallAlerting, on receiving a PROGRESS message on interface X containing a Cause IE, sends a PROGRESS message on interface Y containing a Cause IE encoded as in the incoming PROGRESS message on interface X, and remains in the same state for both interfaces (reference ETS 300 172 [1], subclause 10.4.11.2 and ZC.4).

PSS1_BC/TR/BV/PV/CE/ TC3210OS

- Ensure that the IUT in transit state TCC_CallActive, on receiving a PROGRESS message on interface X containing a Cause IE, sends a PROGRESS message on interface Y containing a Cause IE encoded as in the incoming PROGRESS message on interface X (reference ETS 300 172 [1], subclause 10.4.11.2 and ZC.4).

SP250

- Ensure that the IUT in transit state TCC_Overlap, TCC_TransitCallProceeding or TCC_CallAlerting, on receiving a PROGRESS message on interface Y containing a Cause IE, sends a PROGRESS message on interface X containing a Cause IE encoded as in the incoming PROGRESS message on interface Y, and remains in the same state for both interfaces (reference ETS 300 172 [1], subclause 10.4.11.2).

PSS1_BC/TR/BV/PV/CE/ TC32100U

- Ensure that the IUT in transit state TCC_Overlap, on receiving a PROGRESS message on interface Y containing a Cause IE, sends a PROGRESS message on interface X containing a Cause IE encoded as in the incoming PROGRESS message on interface Y (reference ETS 300 172 [1], subclause 10.4.11.2).

PSS1_BC/TR/BV/PV/CE/ TC32100V

- Ensure that the IUT in transit state TCC_TransitCallProceeding, on receiving a PROGRESS message on interface Y containing a Cause IE, sends a PROGRESS message on interface X containing a Cause IE encoded as in the incoming PROGRESS message on interface Y (reference ETS 300 172 [1], subclause 10.4.11.2).

PSS1_BC/TR/BV/PV/CE/ TC32100X

- Ensure that the IUT in transit state TCC_CallAlerting, on receiving a PROGRESS message on interface Y containing a Cause IE, sends a PROGRESS message on interface X containing a Cause IE encoded as in the incoming PROGRESS message on interface Y (reference ETS 300 172 [1], subclause 10.4.11.2).

SP309

- Ensure that the IUT in transit state TCC_CallActive, on receiving a PROGRESS message on interface Y containing a Cause IE, either sends a PROGRESS message on interface X containing a Cause IE encoded as in the incoming PROGRESS message on interface Y or sends no message on interface X and remains in the same state for both interfaces (reference ETS 300 172 [1], subclause 10.4.11.2).

PSS1_BC/TR/BV/PV/CE/ TC32100W

- Ensure that the IUT in transit state TCC_CallActive, on receiving a PROGRESS message on interface Y containing a Cause IE, either sends a PROGRESS message on interface X containing a Cause IE encoded as in the incoming PROGRESS message on interface Y or sends no message on interface X (reference ETS 300 172 [1], subclause 10.4.11.2).

SP251

- Ensure that the IUT in transit state TCC_AwaitAdditionalDigits, TCC_Overlap, TCC_IncomingCallProceeding, TCC_TransitCallProceeding or TCC_CallAlerting, on receiving a CONNECT message on interface Y containing a Connected Number IE, sends a CONNECT message on interface X containing a Connected Number IE, sends a CONNECT ACK message on interface Y, enters state 8 or 10 for the call on interface X and enters state 10 for the call on interface Y (reference ETS 300 172 [1], subclause 10.4.11.2).

PSS1_BC/TR/BV/PV/CE/ TC32100Y

- Ensure that the IUT in transit state TCC_AwaitAdditionalDigits, on receiving a CONNECT message on interface Y containing a Connected Number IE, sends a CONNECT message on interface X containing a Connected Number IE (reference ETS 300 172 [1], subclause 10.4.11.2).

PSS1_BC/TR/BV/PV/CE/ TC32100Z

- Ensure that the IUT in transit state TCC_Overlap, on receiving a CONNECT message on interface Y containing a Connected Number IE, sends a CONNECT message on interface X containing a Connected Number IE (reference ETS 300 172 [1], subclause 10.4.11.2).

PSS1_BC/TR/BV/PV/CE/ TC3210PA

- Ensure that the IUT in transit state TCC_IncomingCallProceeding, on receiving a CONNECT message on interface Y containing a Connected Number IE, sends a CONNECT message on interface X containing a Connected Number IE (reference ETS 300 172 [1], subclause 10.4.11.2).

PSS1_BC/TR/BV/PV/CE/ TC3210PB

- Ensure that the IUT in transit state TCC_TransitCallProceeding, on receiving a CONNECT message on interface Y containing a Connected Number IE, sends a CONNECT message on interface X containing a Connected Number IE (reference ETS 300 172 [1], subclause 10.4.11.2).

PSS1_BC/TR/BV/PV/CE/ TC3210PC

- Ensure that the IUT in transit state TCC_CallAlerting, on receiving a CONNECT message on interface Y containing a Connected Number IE, sends a CONNECT message on interface X containing a Connected Number IE (reference ETS 300 172 [1], subclause 10.4.11.2).

SP252

- Ensure that the IUT in transit state TCC_AwaitAdditionalDigits, TCC_Overlap, TCC_IncomingCallProceeding, TCC_TransitCallProceeding or TCC_CallAlerting, on receiving a CONNECT message on interface Y containing a Progress Indicator IE, sends a CONNECT message on interface X containing a Progress Indicator IE encoded as in the incoming CONNECT message on interface Y, sends a CONNECT ACK message on interface Y, enters state 8 or 10 for the call on interface X, and enters state 10 for the call on interface Y (reference ETS 300 172 [1], subclause 10.4.11.2 and ZC.4).

PSS1_BC/TR/BV/PV/CE/ TC3210PD

- Ensure that the IUT in transit state TCC_AwaitAdditionalDigits, on receiving a CONNECT message on interface Y containing a Progress Indicator IE, sends a CONNECT message on interface X containing a Progress Indicator IE encoded as in the incoming CONNECT message on interface Y (reference ETS 300 172 [1], subclause 10.4.11.2 and ZC.4).

PSS1_BC/TR/BV/PV/CE/ TC3210PE

- Ensure that the IUT in transit state TCC_Overlap, on receiving a CONNECT message on interface Y containing a Progress Indicator IE, sends a CONNECT message on interface X containing a Progress Indicator IE encoded as in the incoming CONNECT message on interface Y (reference ETS 300 172 [1], subclause 10.4.11.2 and ZC.4).

PSS1_BC/TR/BV/PV/CE/ TC3210PF

- Ensure that the IUT in transit state TCC_IncomingCallProceeding, on receiving a CONNECT message on interface Y containing a Progress Indicator IE, sends a CONNECT message on interface X containing a Progress Indicator IE encoded as in the incoming CONNECT message on interface Y (reference ETS 300 172 [1], subclause 10.4.11.2 and ZC.4).

PSS1_BC/TR/BV/PV/CE/ TC3210PG

- Ensure that the IUT in transit state TCC_TransitCallProceeding, on receiving a CONNECT message on interface Y containing a Progress Indicator IE, sends a CONNECT message on interface X containing a Progress Indicator IE encoded as in the incoming CONNECT message on interface Y (reference ETS 300 172 [1], subclause 10.4.11.2 and ZC.4).

PSS1_BC/TR/BV/PV/CE/ TC3210PH

- Ensure that the IUT in transit state TCC_CallAlerting, on receiving a CONNECT message on interface Y containing a Progress Indicator IE, sends a CONNECT message on interface X containing a Progress Indicator IE encoded as in the incoming CONNECT message on interface Y (reference ETS 300 172 [1], subclause 10.4.11.2 and ZC.4).

SP253

- Ensure that the IUT in transit state TCC_AwaitAdditionalDigits, TCC_Overlap, TCC_IncomingCallProceeding, TCC_TransitCallProceeding or TCC_CallAlerting, on receiving a CONNECT message on interface Y containing a Party Category IE, sends a CONNECT message on interface X containing a Party Category IE encoded as in the incoming CONNECT message on interface Y, sends a CONNECT ACK message on interface Y, enters state 8 or 10 for the call on interface X, and enters state 10 for the call on interface Y (reference ETS 300 172 [1], subclause ZD.2.3.3).

PSS1_BC/TR/BV/PV/CE/ TC3210PI

- Ensure that the IUT in transit state TCC_AwaitAdditionalDigits, on receiving a CONNECT message on interface Y containing a Party Category IE, sends a CONNECT message on interface X containing a Party Category IE encoded as in the incoming CONNECT message on interface Y (reference ETS 300 172 [1], subclause ZD.2.3.3)

PSS1_BC/TR/BV/PV/CE/ TC3210PJ

- Ensure that the IUT in transit state TCC_Overlap, on receiving a CONNECT message on interface Y containing a Party Category IE, sends a CONNECT message on interface X containing a Party Category IE encoded as in the incoming CONNECT message on interface Y (reference ETS 300 172 [1], subclause ZD.2.3.3).

PSS1_BC/TR/BV/PV/CE/ TC3210PK

- Ensure that the IUT in transit state TCC_IncomingCallProceeding, on receiving a CONNECT message on interface Y containing a Party Category IE, sends a CONNECT message on interface X containing a Party Category IE encoded as in the incoming CONNECT message on interface Y (reference ETS 300 172 [1], subclause ZD.2.3.3).

PSS1_BC/TR/BV/PV/CE/ TC3210PL

- Ensure that the IUT in transit state TCC_TransitCallProceeding, on receiving a CONNECT message on interface Y containing a Party Category IE, sends a CONNECT message on interface X containing a Party Category IE encoded as in the incoming CONNECT message on interface Y (reference ETS 300 172 [1], subclause ZD.2.3.3).

PSS1_BC/TR/BV/PV/CE/ TC3210PM

- Ensure that the IUT in transit state TCC_CallAlerting, on receiving a CONNECT message on interface Y containing a Party Category IE, sends a CONNECT message on interface X containing a Party Category IE encoded as in the incoming CONNECT message on interface Y (reference ETS 300 172 [1], subclause ZD.2.3.3).

SP255

- Ensure that the IUT in transit state TCC_AwaitAdditionalDigits, TCC_Overlap, TCC_IncomingCallProceeding, TCC_TransitCallProceeding or TCC_CallAlerting, on receiving a CONNECT message on interface Y containing a Connected Subaddress IE, sends a CONNECT message on interface X containing a Connected Subaddress IE encoded as in the incoming CONNECT message on interface Y, sends a CONNECT ACK message on interface Y, enters state 8 or 10 for the call on interface X, and enters state 10 for the call on interface Y (reference ETS 300 172 [1], subclause 10.4.11.2).

PSS1_BC/TR/BV/PV/CE/ TC3210PS

- Ensure that the IUT in transit state TCC_AwaitAdditionalDigits, on receiving a CONNECT message on interface Y containing a Connected Subaddress IE, sends a CONNECT message on interface X containing a Connected Subaddress IE encoded as in the incoming CONNECT message on interface Y (reference ETS 300 172 [1], subclause 10.4.11.2).

PSS1_BC/TR/BV/PV/CE/ TC3210PT

- Ensure that the IUT in transit state TCC_Overlap, on receiving a CONNECT message on interface Y containing a Connected Subaddress IE, sends a CONNECT message on interface X containing a Connected Subaddress IE encoded as in the incoming CONNECT message on interface Y (reference ETS 300 172 [1], subclause 10.4.11.2).

PSS1_BC/TR/BV/PV/CE/ TC3210PU

- Ensure that the IUT in transit state TCC_IncomingCallProceeding, on receiving a CONNECT message on interface Y containing a Connected Subaddress IE, sends a CONNECT message on interface X containing a Connected Subaddress IE encoded as in the incoming CONNECT message on interface Y (reference ETS 300 172 [1], subclause 10.4.11.2).

PSS1_BC/TR/BV/PV/CE/ TC3210PV

- Ensure that the IUT in transit state TCC_TransitCallProceeding, on receiving a CONNECT message on interface Y containing a Connected Subaddress IE, sends a CONNECT message on interface X containing a Connected Subaddress IE encoded as in the incoming CONNECT message on interface Y (reference ETS 300 172 [1], subclause 10.4.11.2).

PSS1_BC/TR/BV/PV/CE/ TC3210PW

- Ensure that the IUT in transit state TCC_CallAlerting, on receiving a CONNECT message on interface Y containing a Connected Subaddress IE, sends a CONNECT message on interface X containing a Connected Subaddress IE encoded as in the incoming CONNECT message on interface Y (reference ETS 300 172 [1], subclause 10.4.11.2).

NOTE: The following sections in ETS 300 172 [1] concerning the specific call control requirements for Transit PINX do not generate any TP.
10.4.3) Transit state TCC_AwaitAdditionalDigits
T302 expiry - Possible implementation dependant action
10.4.5) Channel through connection procedures
10.4.10.1.ii) Call Clearing not Initiated by the Transit PINX
RELEASE COMPLETE received from subsequent PINX not testable due to unspecified behaviour

5.3.12 Protocol Control requirements for the use of the Signalling Carriage Mechanism

The TPs in this subclause refer to ETS 300 172 [1], subclause 9.1.

SP004

- Ensure that the IUT, in order to initiate a call after its initialization, sends a DL_ESTABLISH_REQUEST primitive before sending any PSS1 message (reference ETS 300 172 [1], subclause 9.1.1).

PSS1_BC/PC/CA/PV/CE/ TC0110XG

- Ensure that the IUT, in order to initiate a call after its initialization (when the SCM is not already established), sends a DL_ESTABLISH_REQUEST primitive before sending any PSS1 message (reference ETS 300 172 [1], subclause 9.1.1).

SP005

- Ensure that the Maximum Message Size generated by the IUT is as stated in the PICS (reference ETS 300 172 [1], subclause 9.1.2 and ZA.3)

NOTE: This STP is referenced in 'Untestable TPs' section in the associated ATS specification document.

SP006

- Ensure that the Maximum Message Size received by the IUT is as stated in the PICS (reference ETS 300 172 [1], subclauses 9.1.2 and ZA.3).

NOTE: This STP is referenced in 'Untestable TPs' section in the associated ATS specification document.

5.3.13 Verification of state

5.3.13.1 Protocol Control State

Where a TP specifies that the IUT enters or remains in a specified protocol control state this is verified as follows:

Ensure that the IUT, on receiving a STATUS ENQUIRY message containing a Call Reference IE encoded with the appropriate call reference flag and value for the relevant call, sends the appropriate response for the expected state (specified in the TP). For all states a STATUS message containing a Call State IE encoded with the expected state and a Cause IE with a cause value encoded as 30 is acceptable. For state 0 a RELEASE or RELEASE COMPLETE message containing a Cause IE with a cause value encoded as 81 is also acceptable. If the expected state is state 2 and an INFORMATION message is received this shall be ignored (reference ETS 300 172 [1], subclauses 9.3.1 and 9.2.3.2).

5.3.13.2 Layer Management State

Where a TP specifies that the IUT enters, or remains in a specified Layer Management state this is verified as follows:

Ensure that the IUT, on receiving a STATUS ENQUIRY message, containing a Call Reference IE encoded with the global call reference, sends a STATUS message with a Call State IE with a Call State value encoded as the expected Layer Management state (specified in the TP) and a Cause IE encoded with cause 81 (reference ETS 300 172 [1], subclause 9.2.3.2).

5.4 Distribution of TPs over Test Suite Structure

Tables 5 to 8 give the distribution of the "final" TPs over the different levels of the TSS.

Table 5: Distribution of TPs over the TSS level 2

TSS 2nd level	Number of "final" derived TPs
Protocol Control	276
Call Control for Originating	8
Call Control for Terminating	15
Call Control for Transit	102
Call Control for Outgoing Gateway	4
Call Control for Incoming Gateway	11

Table 6: Distribution of TPs over the TSS level 3

TSS 3rd level	Number of "final" derived TPs
Basic Interconnection	10
Capability	56
Valid Behaviour	239
Invalid Behaviour	65
Inopportune Behaviour	33
Timer	13

Table 7: Distribution of TPs over the TSS level 4

TSS 4th level	Number of "final" derived TPs
State Event transitions	112
Parameter Variations	304

Table 8: Distribution of TPs over the TSS level 5

TSS 5th level	Number of "final" derived TPs
Call Establishment	236
Call Clearing	94
Message Segmentation	31
Status Procedures	37
Layer management	18

6 Compliance clause

In order to comply with this ETS a Generic or Abstract Test Suite shall:

- a) correspond to a set of test cases, which itself, corresponds to the set of test purposes specified in clause 5 or a subset thereof;
- b) use a test suite structure which is as defined in clause 4, or an appropriate subset thereof;
- c) use names for the test groups and test cases which are the same as, or derived from, the names of corresponding test groups and test purposes in this ETS;
- d) comply with ISO/IEC 9646-2 [5] and ISO/IEC 9646-3 [6].

NOTE: The only subsets of the test suite structure which should be used are those which give complete coverage for one or more profiles, if the ATS does not cover the entire protocol, or those which omit test purposes which are untestable in the chosen Abstract Test Method.

Annex A (informative): Index of test purposes

This index indicates the page number on which each test purpose, super test purpose and combined test purpose is defined.

SP001	16	SP058	30	SP115	49	SP171	67
SP002	16	SP059	31.	SP116	49	SP172	68
SP003	16	SP060	31.	SP117	50	SP173	68
SP004	97	SP061	32	SP118	51.	SP174	68
SP005	97	SP062	32	SP119	51.	SP175	69
SP006	97	SP063	32	SP120	51.	SP176	69
SP007	17	SP064	33	SP121	52	SP177	69
SP008	17	SP065	33	SP122	52	SP178	70
SP009	18	SP066	33	SP123	52	SP179	71.
SP010	18	SP067	33	SP124	53	SP180	71.
SP011	18	SP068	33	SP125	53	SP181	72
SP012	18	SP069	34	SP126	53	SP182	72
SP013	18	SP070	35	SP127	53	SP183	72
SP014	19	SP071	36	SP128	54	SP184	72
SP015	57	SP072	36	SP129	54	SP185	72
SP016	19	SP073	36	SP130	54	SP186	73
SP017	19	SP074	36	SP131	55	SP187	73
SP018	19	SP075	37	SP132	55	SP188	74
SP019	20	SP076	37	SP133	55	SP189	74
SP020	20	SP077	37	SP134	56	SP190	75
SP021	20	SP078	37	SP135	56	SP191	75
SP022	20	SP079	38	SP136	56	SP192	76
SP023	21.	SP080	38	SP137	56	SP193	76
SP024	21.	SP081	38	SP138	57	SP194	77
SP025	21.	SP082	39	SP139	57	SP195	77
SP026	21.	SP083	39	SP140	58	SP196	77
SP027	22	SP084	39	SP141	58	SP197	78
SP028	22	SP085	40	SP142	58	SP198	78
SP029	22	SP086	40	SP143	59	SP199	78
SP030	23	SP087	40	SP144	59	SP200	79
SP032	23	SP088	40	SP145	59	SP201	79
SP033	23	SP089	41.	SP146	59	SP202	79
SP034	23	SP090	41.	SP147	60	SP203	80
SP035	23	SP091	41.	SP148	60	SP204	80
SP036	23	SP093	42	SP149	60	SP205	80
SP037	24	SP094	42	SP150	61.	SP206	80
SP038	24	SP095	43	SP151	61.	SP207	81.
SP039	24	SP096	43	SP152	61.	SP208	81.
SP040	24	SP097	44	SP153	62	SP209	81.
SP041	25	SP098	44	SP154	62	SP210	81.
SP042	25	SP099	44	SP155	62	SP211	82
SP043	25	SP100	44	SP156	62	SP212	82
SP044	25	SP101	45	SP157	63	SP213	82
SP045	26	SP102	45	SP158	64	SP214	82
SP046	26	SP103	45	SP159	64	SP215	83
SP047	26	SP104	46	SP160	64	SP216	83
SP048	26	SP105	46	SP161	64	SP217	83
SP049	27	SP106	46	SP162	63	SP218	83
SP050	27	SP107	46	SP163	63	SP219	84
SP051	28	SP108	47	SP164	63	SP220	84
SP052	28	SP109	47	SP165	66	SP221	84
SP053	29	SP110	47	SP166	66	SP222	85
SP054	29	SP111	48	SP167	66	SP223	85
SP055	29	SP112	48	SP168	66	SP224	85
SP056	30	SP113	48	SP169	67	SP225	85
SP057	30	SP114	49	SP170	67	SP226	85

SP227	86	TC0100XA	25	TC0203SH	42	TC0213WC	46
SP228	86	TC0101CS	32	TC0203SI	42	TC0214TA	46
SP229	86	TC0101CW	33	TC0203SJ	42	TC0214TD	47
SP230	86	TC0110AB	17	TC0203SK	42	TC0214TG	48
SP231	87	TC0110AC	17	TC0203SL	42	TC0214TH	48
SP232	87	TC0110AD	17	TC0203SM	42	TC0214TI	49
SP233	88	TC0110AL	18	TC0203SN	43	TC0214TJ	49
SP234	88	TC0110AM	19	TC0203SO	43	TC0214TK	50
SP235	88	TC0110BE	20	TC0204TC	47	TC0214TL	50
SP236	88	TC0110BS	27	TC0210AI	18	TC0214YH	50
SP237	89	TC0110CB	30	TC0210AZ	19	TC0214YI	50
SP238	89	TC0110JD	20	TC0210BA	19	TC0300AV	57
SP239	89	TC0110XD	16	TC0210BG	22	TC0301HJ	61.
SP240	90	TC0110XE	16	TC0210BT	27	TC0301HK	61.
SP241	91.	TC0110XF	17	TC0210BU	27	TC0301HR	62
SP242	91.	TC0110XG	97	TC0210BW	28	TC0301HS	62
SP243	91.	TC0110YG	17	TC0210BY	29	TC0301XP	57
SP244	92	TC0111CQ	32	TC0210BZ	29	TC0301XR	60
SP245	92	TC0111CX	33	TC0210CA	29	TC0302FG	39
SP246	92	TC0112EL	34	TC0210CC	30	TC0302FH	39
SP247	93	TC0112ES	35	TC0210CD	30	TC0302FJ	40
SP248	93	TC0112ET	35	TC0210CE	31.	TC0302FL	40
SP249	93	TC0112EU	35	TC0210JE	20	TC0310AW	57
SP250	93	TC0112FM	40	TC0210JR	23	TC0310FP	51.
SP251	94	TC0113IG	51.	TC0210KM	27	TC0310FQ	51.
SP252	95	TC0113ST	43	TC0210KN	27	TC0310FR	52
SP253	95	TC0113SZ	45	TC0210KP	27	TC0310FS	52
SP255	96	TC0114TE	47	TC0210KQ	27	TC0310FT	52
SP256	60	TC0114TF	48	TC0210KR	27	TC0310FU	52
SP300	64	TC0200BB	19	TC0210KS	27	TC0310GD	54
SP301	48	TC0200BC	19	TC0210KT	28	TC0310GE	54
SP302	68	TC0200BD	20	TC0211CF	31.	TC0310GL	55
SP303	76	TC0200BQ	25	TC0211CH	31.	TC0310GM	56
SP304	35	TC0200BX	28	TC0211CJ	31.	TC0310GO	56
SP305	36	TC0200JF	21.	TC0211CK	32	TC0310GQ	58
SP306	17	TC0200JG	21.	TC0211CM	32	TC0310GR	58
SP307	50	TC0200JL	22	TC0211CO	32	TC0310GS	58
SP308	71.	TC0200JP	23	TC0211DL	34	TC0310GZ	59
SP309	94	TC0200JW	25	TC0212EM	34	TC0310HE	60
TC0000JU	25	TC0200JX	26	TC0212EN	34	TC0310HF	60
TC0000JV	25	TC0200JY	26	TC0212EO	34	TC0310HT	63
TC0001DI	33	TC0200JZ	26	TC0212EP	34	TC0310HU	63
TC0001DJ	33	TC0200KA	26	TC0212EQ	35	TC0310HV	63
TC0010AJ	18	TC0200KB	26	TC0212ER	35	TC0310HW	63
TC0010AK	18	TC0200XB	25	TC0213EB	44	TC0310XX	61.
TC0100AA	17	TC0200XC	24	TC0213EC	44	TC0311FO	51.
TC0100AE	17	TC0201CG	31.	TC0213ED	45	TC0311FX	53
TC0100BF	22	TC0201CI	31.	TC0213EF	45	TC0311GP	56
TC0100BH	22	TC0201CL	32	TC0213EG	45	TC0311GT	58
TC0100BJ	24	TC0201CN	32	TC0213EH	46	TC0311GU	58
TC0100BK	24	TC0201CP	32	TC0213EI	46	TC0311GV	58
TC0100BL	24	TC0201CR	32	TC0213EK	46	TC0311GW	58
TC0100BN	24	TC0201CU	32	TC0213SA	41.	TC0311GX	59
TC0100BO	24	TC0201DK	33	TC0213SP	43	TC0311GY	59
TC0100BV	28	TC0201XL	31.	TC0213SQ	43	TC0311HB	59
TC0100JH	21.	TC0201XM	31.	TC0213SR	43	TC0311HC	59
TC0100JI	21.	TC0201XN	31.	TC0213SS	43	TC0311HD	60
TC0100JK	22	TC0203SB	41.	TC0213SU	44	TC0311HH	61.
TC0100JM	23	TC0203SC	41.	TC0213SV	44	TC0311HI	61.
TC0100JO	23	TC0203SD	41.	TC0213SX	45	TC0311HL	61.
TC0100JS	25	TC0203SE	42	TC0213SY	45	TC0311HM	61.
TC0100KC	26	TC0203SF	42	TC0213WA	45	TC0311HN	62
		TC0203SG	42	TC0213WB	46	TC0311HO	62

TC0311HP	62	TC0502FN	41.	TC3210LQ	81.	TC3210PZ	89
TC0311HQ	62	TC0510AF	17	TC3210LR	81.	TC3210QA	90
TC0311XO	57	TC0510AH	18	TC3210LS	81.	TC3210QB	90
TC0311XQ	60	TC0510BI	22	TC3210LT	82	TC3210QC	90
TC0312EV	36	TC0510BM	24	TC3210LU	82	TC3210QD	90
TC0312EX	36	TC0510BP	25	TC3210LV	82	TC3210QE	90
TC0312EY	37	TC0510JJ	21.	TC3210LW	82	TC3210QI	91.
TC0312FI	39	TC0510KD	26	TC3210LX	83	TC3210QJ	91.
TC0312FK	40	TC0511CV	32	TC3210LY	83	TC3210QK	92
TC0312YE	35	TC0514TB	47	TC3210LZ	83	TC3210QL	92
TC0312YF	36	TC1110AN	66	TC3210MA	83	TC3210RL	80
TC0314GN	56	TC1110AP	66	TC3210MB	83	TC3210RM	80
TC0314HA	59	TC1110AQ	66	TC3210MC	84	TC3211NB	86
TC0314YD	49	TC1110AR	67	TC3210MD	84	TC3211NC	86
TC0400AX	57	TC1110AS	67	TC3210ME	84	TC3211ND	86
TC0400GA	53	TC1110AT	67	TC3210MF	84	TC3211NE	86
TC0400GB	54	TC1110AU	67	TC3210MG	84	TC3211NF	86
TC0400GF	54	TC1210AO	66	TC3210MH	84	TC3211NG	86
TC0400GG	55	TC2000JB	68	TC3210MJ	85	TC3211NH	87
TC0400HX	64	TC2210JC	68	TC3210ML	85	TC3211NI	87
TC0400HY	64	TC2210JT	68	TC3210OM	92	TC3211NJ	87
TC0401FY	53	TC2210KE	69	TC3210ON	92	TC3211NL	87
TC0401FZ	53	TC2210KG	69	TC3210OO	93	TC3211NM	87
TC0401GH	55	TC2210KH	69	TC3210OP	93	TC3211NN	87
TC0401GI	55	TC2210KI	69	TC3210OS	93	TC3211NO	87
TC0401GJ	55	TC2210KJ	69	TC3210OU	93	TC3211NP	87
TC0401GK	55	TC2210KK	70	TC3210OV	94	TC3211NQ	88
TC0401XS	55	TC2210KL	70	TC3210OW	94	TC3211NR	88
TC0401XT	55	TC2210XJ	69	TC3210OX	94	TC3211NS	88
TC0402FA	37	TC2210XK	69	TC3210OY	94	TC3211NV	88
TC0402FC	38	TC2211KU	70	TC3210OZ	94	TC3211NX	88
TC0402FE	38	TC2211KW	70	TC3210PA	94	TC3211NY	89
TC0402FF	39	TC2211KX	70	TC3210PB	94	TC3211NZ	89
TC0410AY	57	TC3000LA	76	TC3210PC	95	TC3211OA	89
TC0410IA	64	TC3111NK	87	TC3210PD	95	TC3211OC	91.
TC0410IB	64	TC3111NW	88	TC3210PE	95	TC4200VC	75
TC0410IC	64	TC3200LH	78	TC3210PF	95	TC4210EA	74
TC0410YA	65	TC3200LJ	78	TC3210PG	95	TC4210VB	74
TC0410YB	65	TC3210LB	76	TC3210PH	95	TC4210VD	75
TC0410YC	65	TC3210LC	77	TC3210PI	96	TC5000UA	71.
TC0411FV	52	TC3210LD	77	TC3210PJ	96	TC5200UB	71.
TC0411FW	53	TC3210LE	77	TC3210PK	96	TC5210UC	71.
TC0412EW	36	TC3210LF	77	TC3210PL	96	TC5210UD	72
TC0412EZ	37	TC3210LG	81.	TC3210PM	96	TC5210UE	72
TC0412FB	37	TC3210LI	78	TC3210PS	96	TC5210UF	72
TC0412FD	38	TC3210LK	79	TC3210PT	96	TC5210UG	72
TC0414GC	54	TC3210LL	79	TC3210PU	96	TC5210UH	73
TC0500AG	18	TC3210LM	79	TC3210PV	97	TC5210UI	73
TC0501CY	33	TC3210LN	80	TC3210PW	97	TC5210UJ	73
TC0501CZ	33	TC3210LP	81.	TC3210PY	89		

History

Document history	
July 1996	Public Enquiry PE 110: 1996-07-22 to 1996-11-15