



EUROPEAN
TELECOMMUNICATION
STANDARD

DRAFT
pr **ETS 300 795**

November 1996

Source: ETSI TC-SPS

Reference: DE/SPS-03027

ICS: 33.020

Key words: AN, LE, V₅, performance

**Local Exchange (LE) and Access Network (AN);
Performance design objectives
for call handling and bearer connection management**

ETSI

European Telecommunications Standards Institute

ETSI Secretariat

Postal address: F-06921 Sophia Antipolis CEDEX - FRANCE

Office address: 650 Route des Lucioles - Sophia Antipolis - Valbonne - FRANCE

X.400: c=fr, a=atlas, p=etsi, s=secretariat - **Internet:** secretariat@etsi.fr

Tel.: +33 4 92 94 42 00 - Fax: +33 4 93 65 47 16

Copyright Notification: No part may be reproduced except as authorized by written permission. The copyright and the foregoing restriction extend to reproduction in all media.

© European Telecommunications Standards Institute 1996. All rights reserved.

Contents

Foreword	5
Introduction	5
1 Scope	7
2 Normative references	7
3 Definitions and abbreviations	8
3.1 Definitions	8
3.2 Abbreviations	8
4 Transmission characteristics	8
4.1 General	8
4.2 Characteristics of interfaces	9
4.2.1 PSTN access - Interface Z	9
4.2.2 ISDN access - V-type reference points/interfaces	9
4.2.3 Other analogue or digital access for leased lines	9
4.2.4 Interface V ₅	9
4.3 Bearer channel signal transfer delay	9
5 Delay timing characteristics	9
5.1 General	9
5.2 Definition of test points and triggers	10
5.2.1 Test points at user ports	11
5.2.2 Test points at V ₅ interface(s)	11
5.2.2.1 V _{5.1} test point scenario	11
5.2.2.2 V _{5.2} test point scenario	11
5.2.3 Definition of trigger events	11
5.2.4 Signalling transfer delay	12
5.3 Delay probability characteristics	12
5.3.1 Direct impact on service provision at UNI	12
5.3.1.1 Signalling transfer delay	13
5.3.1.2 Processing non-intensive	13
5.3.1.3 Processing intensive	13
5.3.1.4 Non-critical delay timing	13
5.3.2 No direct impact on service provision at UNI	14
5.4 Load Testing on V _{5.1} AN	14
6 Call handling performance objectives	14
6.1 Premature release	14
6.2 Release failure	14
6.3 Other failures	14
7 Transmission performance objectives	14
Annex A (informative): Loading levels	15
A.1 Loading levels	15
A.1.1 "Upper Level" (see Q.543: Reference Load A)	15
A.1.2 "Increased Level" (see Q.543: Reference Load B)	15
A.2 Notes	15
Annex B (informative): Teletraffic aspects - background and teletraffic aspects of AN delay performance objectives	16

B.1	Reference loads.....	16
B.2	Delay parameters	16
Annex C (informative): Performance investigations		17
C.1	General.....	17
C.2	Load investigations in the AN	17
C.2.1	General.....	17
C.2.2	V _{5.1} case - non-concentrating interface	18
C.2.3	V _{5.2} case - concentrating interface.....	20
C.2.4	Practical load tests	20
C.2.4.1	Traffic values	20
C.2.4.2	Call generator adjustment.....	21
C.2.4.3	Test evaluation	22
C.3	Message delay considerations	23
C.3.1	Introduction.....	23
C.3.2	Definition of the trigger events.....	24
C.3.2.1	PSTN ports	24
C.3.2.2	ISDN-BA Ds-data.....	25
C.3.2.3	P-data in the D-channel (ISDN BA)	25
C.3.2.4	Trigger signal production	26
C.3.3	Signal transit time test.....	26
C.3.3.1	Transit time within the AN.....	26
C.3.3.2	Transit time via AN and LE	26
C.3.4	Conclusions.....	27
C.4	Abbreviations (used in annex C).....	27
C.5	Symbols (used in equations)	27
History		28

Foreword

This draft European Telecommunication Standard (ETS) has been produced by the Signalling Protocols and Switching (SPS) Technical Committee of the European Telecommunications Standards Institute (ETSI), and is now submitted for the Public Enquiry phase of the ETSI standards approval procedure.

Proposed transposition dates	
Date of latest announcement of this ETS (doa):	3 months after ETSI publication
Date of latest publication of new National Standard or endorsement of this ETS (dop/e):	6 months after doa
Date of withdrawal of any conflicting National Standard (dow):	6 months after doa

Introduction

The work on a new V interface concept, initiated by a request from the ETSI Technical Assembly (TA), was taken over by a Special Experts Group, set up by TC SPS and working under STC SPS3, with experts from several STCs, e.g. SPS5, TM3 and NA4.

TC SPS identified in the terms of reference two interface concepts, one called the V_{5.1} interface, based on a static multiplexing principle, and the other called the V_{5.2} interface, based on a dynamic, concentrator type, principle.

The following set of standards form part of the V₅ concept:

ETS 300 324-1 (1994): "V_{5.1} interface for the support of Access Network (AN)" (G.964);

ETS 300 347-1 (1994): "V_{5.2} interface for the support of Access Network (AN)" (G.965);

ETS 300 376-1 (1994): "Q3 interface specification to the access network for the configuration management of V₅ interface and associated user ports" (Q.57CM);

ETS 300 378-1 (1995): "Specifications of the Q3 interface to the access network for the support of V₅ interfaces; Fault and performance management of V₅ interfaces and associated user ports" (Q.57FPM).

This ETS includes a number of informative annexes:

Annex A: Loading Levels; Performance can be measured, independent of services applied. Reference loads are specified for a characteristic mix of originating and terminating call attempts.

Annex B: Teletraffic Aspects; Background and Teletraffic aspects of AN delay performance objectives.

Annex C: Performance Investigations.

Blank page

1 Scope

This European Telecommunication Standard (ETS) specifies the performance design objectives of an Access Network (AN) for call handling and bearer channel connection management. It is assumed that the Local Exchange (LE) meets delay criteria as recommended by ITU-T Recommendation Q.543 [9]. Specified delays for the AN are additional to the ones for the LE. This ETS is applicable to both the V_{5.1} interface as specified in ETS 300 324-1 [1] and V_{5.2} interface as specified in ETS 300 347-1 [2].

Relationship of design performance requirements to operational performance requirements as defined within this ETS, should be considered as design objectives for systems under the conditions stated in this ETS. These conditions are defined by such parameters as average circuit occupancy, busy hour call attempts, etc. They should be distinguished from the operational performance requirements which AN and service providers establish for remote access arrangements across interfaces at the V₅ reference point operating in their specific environment.

2 Normative references

This ETS incorporates by dated or undated reference, provisions from other publications. These normative references are cited at the appropriate places in the text and the publications are listed hereafter. For dated references subsequent amendments to, or revisions of, any of these publications apply to this ETS only when incorporated in it by amendment or revision. For undated references the latest edition of the publication referred to applies.

- [1] ETS 300 324-1: "Signalling Protocols and Switching (SPS); V interfaces at the digital Local Exchange (LE); V_{5.1} interface for the support of Access Network (AN); Part 1: V_{5.1} interface specification".
 - [2] ETS 300 347-1: "Signalling Protocols and Switching (SPS); V interfaces at the digital Local Exchange (LE); V_{5.2} interface for the support of Access Network (AN); Part 1: V_{5.2} interface specification".
 - [3] ETS 300 463 (1996): "Transmission and Multiplexing (TM); Requirements of passive Optical Access Networks (OANs) to provide services up to 2 Mbit/s bearer capacity".
 - [4] ETS 300 011 (1992): "Integrated Services Digital Network (ISDN); Primary rate user-network interface; Layer 1 specification and test principles".
 - [5] ETS 300 012 (1992): "Integrated Services Digital Network (ISDN); Basic user-network interface Layer 1 specification and test principles".
 - [6] ETS 300 166 (1993): "Transmission and Multiplexing (TM); Physical and electrical characteristics of hierarchical digital interfaces for equipment using the 2 048 kbit/s - based plesiochronous or synchronous digital hierarchies".
- NOTE 1: This ETS is based on ITU-T Recommendation G.703 (1991).
- [7] ETS 300 233 (1994): "Integrated Services Digital Network (ISDN); Access digital section for ISDN primary rate".
- NOTE 2: This ETS is based on ITU-T Recommendation G.962 (1993).
- [8] ETS 300 297 (1995): "Integrated Services Digital Network (ISDN); Access digital section for ISDN basic access".
- NOTE 3: This ETS is based on ITU-T Recommendation G.960 (1993).
- [9] ITU-T Recommendation Q.543 "Digital exchange performance design objectives".
 - [10] ITU-T Recommendation Q.551: "Transmission characteristics of digital exchanges".

[11] ITU-T Recommendation Q.552: "Transmission characteristics at 2-wire analogue interfaces of digital exchanges".

[12] ITU-T Recommendation Q.554 "Transmission characteristics at digital interfaces of a digital exchanges".

3 Definitions and abbreviations

3.1 Definitions

For the purposes of this ETS the following definitions apply:

Access Network (AN): A system implemented between the Local Exchange (LE) and the user, replacing part or the whole of the local line distribution network.

bearer channel: A 64 kbit/s time slot in the V₅ interface, allocated for a B-channel of an ISDN user port or a PCM encoded 64 kbit/s channel for a PSTN user port.

control: Is concerned with status and control of user ports, V₅ interface layer 1 and 2 establishment and other common procedures.

Local Exchange (LE): An exchange on which user lines are terminated via an AN.

Q3 interface: A general term for the family of Q interfaces for the OAM&P of network elements (e.g., a Q3-AN or Q3-LE interface).

V5 interface: A general term for the family of V interfaces for connection of ANs to the LE (e.g., a V_{5.1} or V_{5.2} interface).

3.2 Abbreviations

For the purposes of this ETS, the following abbreviations apply:

AN	Access Network
BCC	Bearer Channel Connection
C-channel	Communication channel
C-path	Communication path
DC	Direct Current (feeding, signalling)
FSM	Finite State Machine
ISDN	Integrated Services Digital Network
ISDN-BA	ISDN-Basic Access
ISDN-PRA	ISDN-Primary Rate Access
LE	Local Exchange
NT1	Network Termination type 1
PCM	Pulse Code Modulation
PSTN	Public Switched Telephone Network
UNI	User-Network Interface

4 Transmission characteristics

4.1 General

The general definitions associated with transmission characteristics and transmission parameters from a total perspective such as group delay and the transfer functions for jitter and wander are provided in ITU-T Recommendations Q.551 [10], Q.552 [11] and Q.554 [12]. These Recommendations define, for any bearer channel connection which may be set up, the necessary levels of transmission performance to conform with overall objectives for the complete user-to-user connections in which an AN may be involved.

4.2 Characteristics of interfaces

The interfaces taken into account are those defined in the V5.1 and V5.2 specifications. For voice-frequency interfaces (i.e. Z and analogue leased lines), the electrical parameters refer to the appropriate distribution frame, on the assumption that the length of the cabling between the distribution frame and the AN does not exceed 100 m. For corresponding limitations on the location of digital interfaces, see ETS 300 166 [6].

4.2.1 PSTN access - Interface Z

The interface Z provides for the connection of two-wire analogue subscriber lines and will carry signals such as speech, voice-band data and multi-frequency push button signals, etc. In addition interface Z shall provide for DC feeding the subscriber set and ordinary functions such as DC signalling, ringing and metering, etc., where appropriate.

Detailed transmission characteristics for this interface are provided in ITU-T Recommendation Q.552 [11]; clauses "Characteristics common to all 2-wire analogue interfaces" and "Characteristics of interface Z".

4.2.2 ISDN access - V-type reference points/interfaces

The AN supports the following ISDN access types:

- ISDN basic access;
- ISDN primary rate access (not for V5.1);

both with or without NT1 integrated in the AN.

For the detailed characteristics of these ISDN accesses reference should be made to the following documents:

- ETS 300 297 [8] for ISDN basic access with NT1 separate for the AN;
- ETS 300 012 [5] for ISDN basic access with NT1 integrated in the AN;
- ETS 300 233 [7] for ISDN primary rate access with NT1 separate from the AN;
- ETS 300 011 [4] for ISDN primary rate access with NT1 integrated in the AN.

4.2.3 Other analogue or digital access for leased lines

The characteristics of these accesses are for further study.

4.2.4 Interface V5

The V5 interface have transmission characteristics as given in ITU-T Recommendation Q.554 [12]; clause "Interface characteristics at interface A", case of 2 048 kbit/s.

4.3 Bearer channel signal transfer delay

Bearer channel signal transfer delay is specified for the transmission capability of allocated B-channels (ISDN access) or PCM encoded 64 kbit/s channels (PSTN access) and is defined in ETS 300 463 [3]; clause "Signal transfer delay".

5 Delay timing characteristics

5.1 General

The delay timing characteristics are defined in terms of "trigger events" which can be observed at "test points" specified for the AN configuration.

Figure 1 illustrates the general location of such "test points" for the definition of delay timings, i.e. at the user ports and the V5 interface(s).

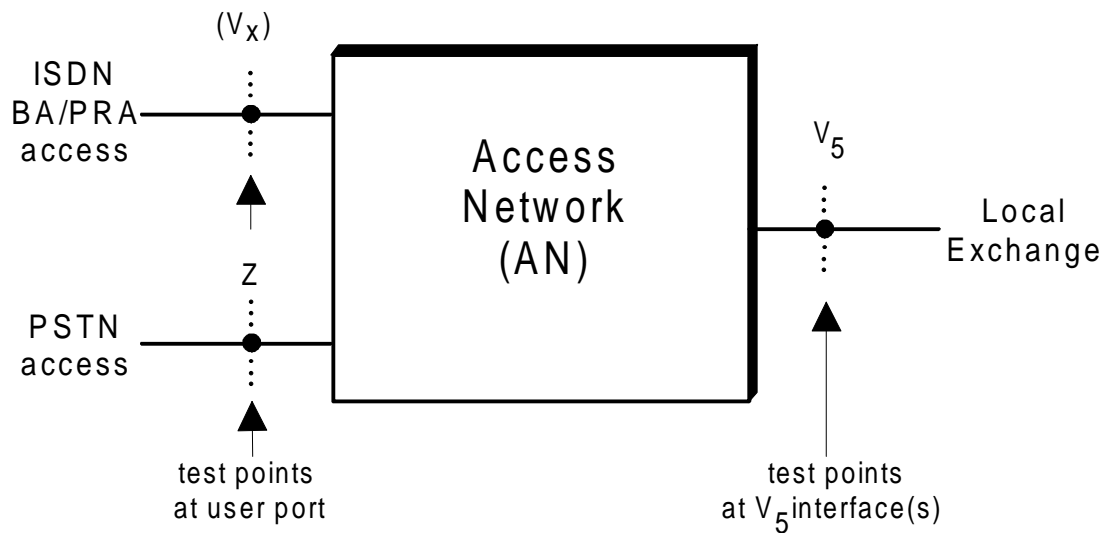

Figure 1: Test points for AN configuration

For ISDN accesses the test point is related to the D-channel carrying all information types, i.e. Ds-data, p-data and f-data.

At the V_5 interface (protocol) information from different user accesses as well as from AN internal protocol entities and FSMs is transported on the communication path (C-path). In order to enable an unambiguous specification of delay timing parameters and values, separate test points for all the different information types are defined. On the V_5 interface separate logical test points are defined for each of the different information types, i.e. ISDN Ds-data, ISDN p-data, ISDN f-data, PSTN signalling information, control protocol, the link control protocol, etc.

5.2 Definition of test points and triggers

For the definition of delay parameters and values of the AN, the following general approach is used:

a) At PSTN user ports

For signals from the PSTN terminal the delay timing shall begin with the occurrence of the relevant line signal change at the user port representing that particular PSTN signal, e.g. an on-hook should begin at the time where the loop current falls below a certain value (i.e., any persistency checking time is excluded).

For signals from the user port the delay timing shall terminate with the relevant line signal change at the user port line side representing that particular PSTN signal.

This approach supports the definition of conformance statements and tests. It requires the definition of the voltage and/or current values for the triggering of the measurement at the port on the basis of the national PSTN protocol mapping implemented in the AN.

b) At ISDN user ports

For signals from the ISDN terminal the delay timing shall begin with the end of the closing flag of the relevant message in the D-channel at the ISDN user port.

For signals from the user port the delay timing shall terminate with the end of the opening flag of the relevant message in the D-channel at the user port.

This approach limits the impact on the delay timing value from the message length as much as possible. Furthermore the requirement shall be verified at the ISDN user ports having the relevant user-network interface implemented. This avoids impact from the transmission system used and simplifies the measurement.

c) At the V₅ interface

For messages received from the LE the delay timing shall begin with the end of the closing flag of the relevant message in the C-channel at the V₅ interface.

For messages sent from the AN the delay timing shall terminate with the end of the opening flag of the relevant message in the C-channel at the V₅ interface.

This approach limits the impact on the delay timing values from the message length as much as possible.

5.2.1 Test points at user ports

At the user port the test point is defined either:

- on the analogue line wires of the PSTN access (interface Z); or
- on the D-channel of the ISDN access.

5.2.2 Test points at V₅ interface(s)

At the V₅ interface(s) separate test points are defined for the different types of data which are conveyed over this interface as communication paths. This definition is made in order to avoid the overlapping effect of queuing delays inside the AN.

According to the maximum number of 2 048 kbit/s interfaces and communication channels (C-channels) defined for the individual types of V₅ interfaces (i.e. V_{5,1} and V_{5,2}) the following scenarios are presented.

5.2.2.1 V_{5,1} test point scenario

The V_{5,1} interface consists of a single 2 048 kbit/s link supporting the capability of three communication channels.

The following test environment is defined for the V_{5,1} interface which requires that the individual types of data to be conveyed over the V_{5,1} interface, are assigned through provisioning for each scenario to be tested.

Table 1: Test scenario for the V_{5,1} interface

C-channel No.	time slot	provisioned for
1	16	control communication
2	15	type of data under test (note)
3	31	other types of data (note)
NOTE: Type of data: Ds-type data, PSTN signalling information, p-type data, f-type data.		

5.2.2.2 V_{5,2} test point scenario

The V_{5,2} interface can have up to a sixteen 2 048 kbit/s links supporting a maximum capability of 16 x 3 communication channels.

The time slot allocation for physical communication channels as given in the V_{5,2} specification shall be applied taking into account that the individual types of data to be conveyed over the V_{5,2} interfaces shall be placed in separate logical C-channels.

In the case of only one 2 048 kbit/s link the test scenario (i.e. allocation of communication channels) may be the same as given for the V_{5,1} interface.

5.2.3 Definition of trigger events

In defining delay timing performance parameters an AN reference event is the transfer of a discrete (protocol) information element across an AN test point. Two classes of reference events are distinguished:

Entry event: a reference event that corresponds to a (protocol) information element entering the AN;

Exit event: a reference event that corresponds to a (protocol) information element exiting the AN.

5.2.4 Signalling transfer delay

For the delay value the occurrence of an entry event is defined to be the stop-flag of the received message. The exit event is defined as the start-flag of the sent message.

If the signalling transfer delay were measured from start-of-receipt to start-of-sending, then ISDN D-channel frame **length** would have to be accounted for.

For analogue signals, any persistence checking is excluded from the signal transfer delay.

5.3 Delay probability characteristics

This category of AN performance requirements, which is related to the logical communication channels carrying the different information types of one or more communications paths, is split into two kinds of classes:

- 1) having a direct impact on service provision at UNI;
- 2) not having direct impact on service provision at UNI - e.g. audit procedure process.

The delay timings are specified under certain loading conditions and are expressed where appropriate in terms of mean and 95 % probability values. The term "mean" is taken to be the expected value of delay in the statistical sense. The "95 % probability" value is taken as the limit within which 95 % of the delays fall. Delays at higher loading levels are for further study.

Annex A defines the used "Loading Levels", whereas annex B gives "Background and Teletraffic aspects of AN delay performance objectives".

5.3.1 Direct impact on service provision at UNI

This class of performance requirements covers the delay timing characteristics which have a direct impact on the service provision at the User-Network Interface (UNI) as seen by a subscriber connected via the AN to the LE.

Within this class of performance requirements the following delay timings have to be considered:

- ISDN D-channel information;
- PSTN signalling information;
- Control information;
- Link control information;
- Bearer channel connection (BCC) allocation/de-allocation protocol;
- Protection switch over protocol.

According to the different information types a general classification can be made which defines:

- 1) Critical delay timings, e.g. ISDN Ds-data and PSTN signalling. For the critical delay timings it is proposed to specify three types of performance parameters:
 - a) Processing intensive (i.e. functions/reactions of processes involving the system management);
 - b) Processing non-intensive (i.e. responses provide by a FSM);
 - c) Routeing/transfer or signalling transfer delay (i.e. to transfer (protocol) information from one port to another with minimal or no other actions required in the AN).
- 2) Delay timings which are considered as not critical, i.e. ISDN P-data and F-data. For such delay timings no further subdivision may be required which means that a single set of values should be specified.

5.3.1.1 Signalling transfer delay

This type of performance parameter covers the time taken by the AN or LE to transfer a signal, no other action being required.

Signalling transfer delay is defined as the time interval between the occurrence of an entry event and a performance significant exit event.

Table 2: Signalling transfer delay probability

Loading level	Upper level	Increased level
Mean value	≤ 100 ms	≤ 175 ms
P = 0,95 of not exceeding	200 ms	350 ms

5.3.1.2 Processing non-intensive

This type of performance parameter covers procedures which are processing non-intensive, e.g. actions or functions provided by the finite state machine (FSM).

Processing non-intensive delay is defined as the time interval between the occurrence of an entry event and a performance significant exit event.

The figures in ITU-T Recommendation Q.543 [9] for exchange signalling transfer delay, would seem to be reasonable for AN signalling transfer delay and processing non-intensive AN procedures, as follows (see also annex B for background information).

Table 3: Processing non-intensive delay probability

Loading level	Upper level	Increased level
Mean value	≤ 200 ms	≤ 350 ms
P = 0,95 of not exceeding	400 ms	700 ms

5.3.1.3 Processing intensive

There is no need for specifying performance parameters for maintenance procedures, which have no direct impact on call handling. In these cases it is sufficient that the system complies with the relevant protocol timers. This applies to all common control and block/unblock procedures.

Furthermore, performance parameters have no relevance for the system's behaviour under failure conditions.

5.3.1.4 Non-critical delay timing

This type of performance parameter covers the time taken by the AN or LE to transfer ISDN P-data and F-data.

Signalling transfer delay is defined as the time interval between the occurrence of an entry event and a performance significant exit event. The values are given in table 4.

Table 4: Non-critical delay probability

Loading level	Upper level	Increased level
Mean value	≤ 1 000 ms	≤ 1 200 ms
P = 0,95 of not exceeding	1 200 ms	1 500 ms

5.3.2 No direct impact on service provision at UNI

This class of performance requirements covers procedures which are not seen by a subscriber but which contribute to the overall performance of the AN.

Further definition of this performance requirement class is not covered by this ETS.

5.4 Load Testing on V5.1 AN

Annex C presents data from field experience on dynamic behaviour of V5.1 ANs.

Three types of investigation are presented:

- 1) load tests under realistic (simulated worst-case) conditions;
- 2) measurements of signal delays in AN, under traffic load;
- 3) behaviour of AN-under-load, while being manipulated (maintenance type of activities).

6 Call handling performance objectives

6.1 Premature release

The probability that an AN malfunction will result in the premature release of an established connection in any one minute interval shall be:

$$P \leq 2 \times 10^{-5}$$

6.2 Release failure

The probability that an AN malfunction will prevent the required release of a connection shall be:

$$P \leq 2 \times 10^{-5}$$

6.3 Other failures

The probability of the AN causing a call failure for any other reason not identified specifically above shall be:

$$P \leq 10^{-4}$$

7 Transmission performance objectives

The probability of the AN causing a connection being established with an unacceptable transmission quality shall be:

$$P \leq 10^{-5}$$

Annex A (informative): Loading levels

A.1 Loading levels

The AN performance can be measured, independent of services applied. The V₅ protocols only handle individual events, with the AN ignorant of call states, or services. Reference loads are specified for a characteristic mix of originating and terminating call attempts.

A.1.1 "Upper Level" (see Q.543: Reference Load A)

This represents the normal upper mean level of activity on V₅ bearer channels with on-demand service.

- Upper Level is defined as the C-channel occupancy which is required for the following bearer channel occupancy:

0,7 E average occupancy on all V₅ bearer channels.

- Call attempts/h (BHCA) =

$(0,7 \times \text{number of V}_5 \text{ bearer channels}) / (\text{average holding time in hours}).$

A.1.2 "Increased Level" (see Q.543: Reference Load B)

This represents an increased level, beyond normal planned activity levels.

- Increased Level is defined as the C-channel occupancy which is required for the following bearer channel occupancy:

1,2 x (upper level occupancy); equivalent to 0,84 E bearer channel occupancy.

- Call attempts/h =

1,28 x (upper level BHCA).

A.2 Notes

The loading levels for other C-channels, covering P- and F-type data packets, are for further study.

The applicability of these reference loads to the V_{5.1} situation (no concentration) is questionable, since the V₅ bearer channel occupancy is equal to subscriber line loading. However, since ITU-T Recommendation Q.543 [9] subscriber line traffic model case Y''' uses 0,55 E per B-channel, only 21 % below reference load A (0,7 E), and a single 2 048 kbit/s link should always be a least onerous case, it is probably not worth making V_{5.1} a special case.

Annex B (informative): Teletraffic aspects - background and teletraffic aspects of AN delay performance objectives

B.1 Reference loads

ITU-T Recommendation Q.543 [9] specifies reference loads on inter-exchange circuits and on subscriber lines, as a basis for the performance design objectives. Reference load A is intended to be representative of the normal maximum busy hour traffic, for which switching resources and inter-exchange circuits are generally provisioned; typically the mean for the 30 highest busy hours of the year (excluding exceptional days such as Christmas). Reference load B is intended to be representative of reasonably frequently occurring overload conditions, for which the network can be expected to provide an acceptable level of degraded performance; typically the mean for the 5 highest busy hours.

For incoming inter-exchange circuits, reference load B is 1,14 times (i.e. 0,8/0,7) reference load A for circuit occupancy and 1,2 times for Busy Hour Call Attempts (BHCA). For subscriber lines (originating traffic), the ratios are 1,25 for originating line occupancy and 1,35 for originating BHCA. The higher ratios used for BHCA, relative to those for occupancy, reflect the escalation in repeat attempts with higher traffic loading levels.

The lower reference load B to reference load A ratios for incoming inter-exchange circuits, compared with those for subscriber lines, are due to the traffic smoothing which occurs in the network, as a result of mixing of traffic from diverse traffic sources and of network congestion.

ANs and Service Node Interfaces (SNI), such as V₅, will experience some smoothing due to dilution of originating traffic with terminating traffic and, in the case of a concentrating SNI such as V_{5.2}, congestion on the interface. It would therefore seem to be appropriate to use loading ratios intermediate between those for subscriber lines and those for inter-exchange circuits.

B.2 Delay parameters

Delay parameter value differentials should reasonably reflect the traffic handling properties of single servers, which are generally appropriate to signalling handling in ANs and LEs. As a simple example, for a server operating at 0,5 occupancy (high for a signalling channel but not necessarily for a processor), an increase in loading of 28 % results in an 80 % increase in mean delay. Also for 0,5 occupancy, there is a 5 % probability of the delay exceeding 4 times the mean, for constant service time, or 4,6 times the mean, for negative exponentially distributed service time.

Traffic dependent queuing delays are not the only delays involved and, in practice therefore, the delay differentials will generally not be so large.

Annex C (informative): Performance investigations

The information in this annex is provided to support network operators with the type-approval of V₅ ANs, before planned deployment. It does not lay any additional requirements on the implementation of V₅ ANs.

The following considerations are based on the ideas and practical experience gained during tests of ANs produced by different manufacturers, within the framework of the OPAL project before installing the network of the Deutsche Telekom AG (DTAG); (OPAL is a DTAG project name for optical access line).

C.1 General

During the AN application preparation the dynamic behaviour of the system will be investigated. In this connection three essential types of investigations of the AN dynamic behaviour will be interesting:

- load tests under simulated operational conditions;
- signal delay measurements in the AN in different load conditions;
- behaviour investigations of the AN under loading conditions during AN manipulations (e.g. configuring, pull/plug-in modules etc.).

The setting-up of real load conditions will demand AN traffic considerations. For these we will distinguish between:

- non-concentrating interfaces (V_{5.1} case) with the LE;
- concentrating interfaces (V_{5.2} case) to the LE.

The starting point of load compatibility considerations is to load the AN with the subscriber traffic corresponding to the most unfavourable, but realistic operating conditions. During the tests it will have to be guaranteed that the traffic will be freely received by the LE, i.e. the LE direction shall be able to handle the traffic at the LE side without any loss. Compared with the non-concentrating interfaces where only the message traffic investigation on the C-channels will be of interest, since in any case the B-channels are permanently assigned to a subscriber line, the concentrating interfaces will have to be considered as trunk groups. This demands a completely different approach. Furthermore, the inclusion of traffic load caused by the packet data transmission in the D-channel of the ISDN-BA will be a point of interest. But the inclusion of this traffic type is very complicated, because until now comprehensive experiences of real traffic values have not yet been available. At present this service is being used by a relatively small number of customers in the DTAG network. An important precondition of the performance investigation is the thorough analysis of the AN architecture depending on the AN manufacturer and therefore probably leading to different configurations for the intended investigations.

C.2 Load investigations in the AN

C.2.1 General

For all load considerations it has proved to be useful to define the "bottleneck" effecting the limitation of the traffic processing capacity. It is directly connected to the system architecture. In the case of concentrating interfaces the interface structure at the LE side will be considered. The "bottleneck" is characterized by the fact that a partial system of the AN handles the protocol processing and call control for a certain group of V₅-IF. Such partial systems can be multiple in the AN, excluding interaction between them as a rule. Furthermore the performance of the load behaviour tests is connected with the interest of using a small number of subscribers, because on the one hand only a limited number of AN modules are available and on the other hand the provision expenditures (call generators, cabling expenditure, LE interfaces) will have to be kept small. Thus, the load investigations will be additionally affected by "practical constraints". For this reason it will be advantageous to perform the load investigations at the "bottleneck" and to make conclusions of the overall system. Taking the load behaviour into consideration, the involvement of the different connection types (PSTN, ISDN) and thus the ISDN-BA with PTMP and those with a permanent active layer 1 - PTP (for PBX) and packet data transmission will be important.

NOTE: The planned P data transmission in the D-channel of the ISDN-BA surely contributes to a further traffic load of the AN control, but can not be considered in the previous load tests until now.

Each telephone line generates an average subscriber traffic value during the busy hour (y_T). The concerned connections are characterized by an average holding time t_m . Both quantities depend on the line usage. For the different connection types such values are available from DTAG guidelines and ITU-T Recommendations as well as from current DTAG measurements.

To simplify the load tests the following commitments are determined:

- outgoing and incoming subscriber traffic values are assumed as equal ones:

$$\frac{1}{2} y_T = y_{Tg} = y_{Tk} \quad (\text{equation 1})$$

- no traffic losses are allowed in the LE;
- the test traffic is produced by call generators, it passes the AN to the LE as outgoing traffic and reaches the call generators again via the AN as incoming traffic.

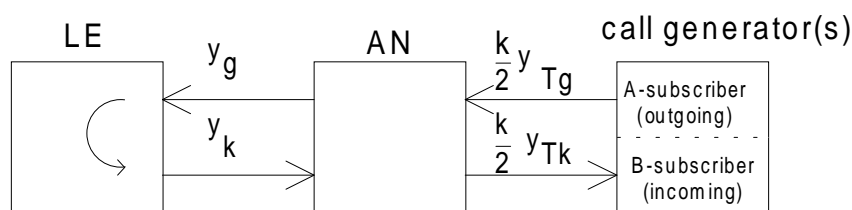

Figure C.1: Traffic flow during the loading tests

C.2.2 V5.1 case - non-concentrating interface

The loading tests are aimed at checking the AN control, regarding the internal message processing and communication with the LE on the C-channels at a maximum, practical traffic volume. (As a rule) each line produces outgoing traffic y_{Tg} and receives incoming traffic y_{Tk} . During the call set-up and tear-down (and partially during calls) messages are produced which have to be processed by the AN control and transmitted via signalling channel (C-channel) from and to the LE.

Each PSTN line is allocated to a fixed bearer channel (B-channel) in the AN. And for each ISDN line both B-channels are also allocated. The B-channels allocated to the lines by the management, can be regarded as "connected straight through the AN". The AN does not fulfil a concentration function, i.e. regarding the AN traffic to be processed the B-channels are not considered.

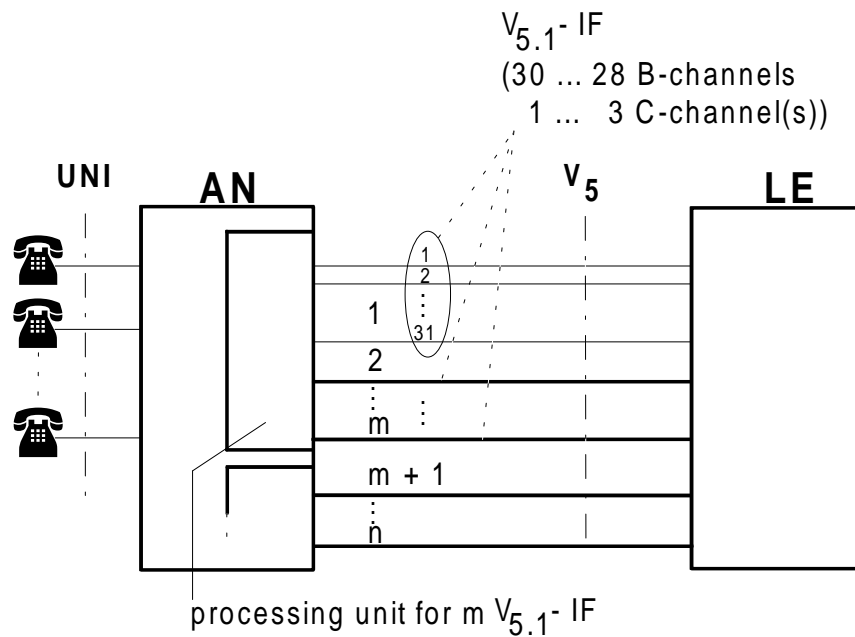

Figure C.2: Survey of V_{5.1} case

To handle the message traffic in the AN other conditions are available:

Within a V_{5.1} all messages (for calls in both directions) are transmitted in the C-channels 15, 16 and 31 (preferred in the 16th channel), i.e. the message traffic of a V_{5.1} is concentrated in its own C-channel(s).

Depending on the internal system structure the message traffic is concentrated again in the AN in the manner that the message traffic of several V_{5.1} interfaces is handled via one processor system. This processor system is the "bottleneck" with regard to the message load to be processed. During the load test it should be recognized that this "bottleneck" is able to process the message traffic occurring during operation, generated by the maximum practically occurring subscriber traffic values.

By a suitable testing configuration it has to be guaranteed that the traffic is not limited in the LE, because the behaviour of the AN and not the LE capability shall be tested. Since the message amount (to be processed by the AN control) is widely independent on the speech time, the call durations can be reduced without any great problems to increase the message load. To adjust the call generator during the AN test within the framework of DTAG projects the following commitments are determined:

- the loading tests are performed on the basis of the maximum traffic load really expected, i.e. the situation of the peak traffic hour will be extended to the whole test duration;
- the tests are performed on the assumption, that only one C-channel is configured and thus 30 B-channels are used at one interface;
- at each V_{5.1} (= a 2 048 kbit/s interface) 15 outgoing PSTN lines and 15 incoming PSTN lines are operated.

At each V_{5.1} the total outgoing traffic is:

$$y_{g(2M)} = \frac{30}{2} \times y_T = y_{k(2M)} \quad (\text{equation 2})$$

The V_{5.1} interfaces are operated for one half in the outgoing and for the other half in the incoming direction.

For the "bottleneck" the following traffic has to be adjusted in the outgoing direction:

$$y_{g-ges} = \frac{30}{2} \times y_T \times n \quad n = \text{number of V}_{5.1} \text{ interfaces for each "bottleneck"}. \quad (\text{equation 3})$$

The BHCA value is the number of call attempts during the peak traffic hour for each line. In general the BHCA value is:

$$C_{BHCA} = \frac{y_T}{t_m} \times 3600 \frac{[E]}{[s]} \tag{equation 4}$$

and as an overall BHCA value for outgoing traffic:

$$C_{BHCA-ges} = \frac{30}{2} \times y_T [E] \times n \times \frac{3600}{t_m} [s] \tag{equation 5}$$

This overall BHCA value is distributed equally over the call generators to be connected.

C.2.3 V5.2 case - concentrating interface

In the V5.2 case the AN and LE are interconnected by several 2 048 kbit/s links belonging to one V5.2 interface. In the DTAG network (vendor-specific) concentrating interfaces are also used with only one 2 048 kbit/s link, having nearly the same conditions.

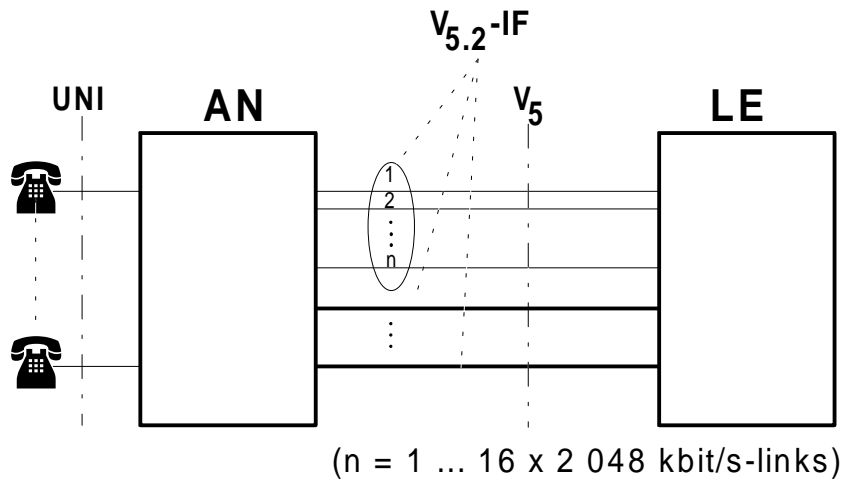

Figure C.3: survey of V5.2 case

On the other hand one AN can be interconnected with the LE via several V5.2 interfaces. Here the "bottleneck" is the individual concentrating interface. As a rule it has to be regarded as a trunk group - (excluded from the trunk group are "preconnected lines" and "semipermanent lines" - if available). Within a trunk group the B-channels can replace each other. For this trunk group of B-channels a maximum traffic performance with an agreed loss is given by the LE side. The maximum load is determined by the traffic performance given by the LE manufacturer for the concerned V5.2 configuration. But here it is also possible to simulate an "increased message traffic" in the C-channels by reducing the speech durations to investigate the system's behaviour or its limits. Furthermore, the message and P data traffic distribution considerations on the C-channels are important. Here the AN has to adapt to the basis of the V5.2 structure given by the LE.

C.2.4 Practical load tests

C.2.4.1 Traffic values

At the UNI a special traffic behaviour exists, to be regarded for each (PSTN) line as one trunk group with one line or for the ISDN-BA as a trunk group with two lines. That means that the lines of different subscribers do not replace each other and the behaviour is much more dependent on coincidences than that of a bigger subscriber group. Determining an average behaviour of a traffic source group, as done for the consideration of one trunk group or of a whole LE or for example of central LE units, is not possible for the individual customer. Therefore the calculations were done on the basis of special, relatively high, traffic values on the subscriber lines, resulting from the most unfavourable, but practically possible application case. For the mean holding time value on the subscriber line the result is the shortest time of outgoing traffic occurring on the communication path (dialling interruption, unintended off-hook etc.), since

no "filtering selection stages" lie in front of it. On the incoming side it is the opposite, i.e. only the real call attempts reach the B subscriber. Thus a special (relatively short) t_m time has to be expected. In the DTAG network the biggest subscriber traffic values occur on the DDI subscriber lines. For this reason these values are included in the load behaviour consideration.

Since the available call generators do not yet support DDI signalling, the load tests are performed by means of the analogue telephone accesses PSTN and pulse dialling (dialling including the area code).

In the following the available traffic values are given for the telephone accesses:

Table C.1: ITU subscriber traffic values

Access type	Average traffic intensity per line y_T [E]
"Non ISDN- subscriber lines"	0,03...0,17

In the DTAG network comprehensive investigations of the subscriber traffic values were performed:

Table C.2: Subscriber traffic values according to DTAG investigations

Access type	Average traffic intensity per line y_T [E]
PSTN-line without DDI	0,052
PSTN-line with DDI	0,36...0,51
ISDN-BA (PTMP) [2 channels]	0,4
ISDN-BA (PTP) [2 channels]	0,49
ISDN-PMX [30 channels]	15,5

For the average holding time t_m the following values were measured:

Table C.3: Average holding time according to DTAG investigations

Traffic type		Holding time t_m [s]	
		range	average
local traffic	working day- morning	96...107	103
	working day - evening	122...142	128
	Sunday and bank holiday	113...139	130
long distance traffic	working day- morning	108...119	112
	working day - evening	124...159	144
	Sunday and bank holiday	107...174	151

For load investigations in the OPAL AN the following values were selected:

- $t_m = 90$ s;
- $y_T = 0,5$ E x peak value factor 1,2 = **0,6 E**.

On the basis of these values the BHCA value of the outgoing traffic is calculated according to equation 5:

$$C_{BHCA-ges} = \frac{30}{2} \times y_T [E] \times n \times \frac{3600}{t_m [s]} = \mathbf{360 \text{ BHCA}}$$

C.2.4.2 Call generator adjustment

Adjusting the used call generators demands the determination of some time periods to generate the required traffic load. The following figure gives a survey of it:

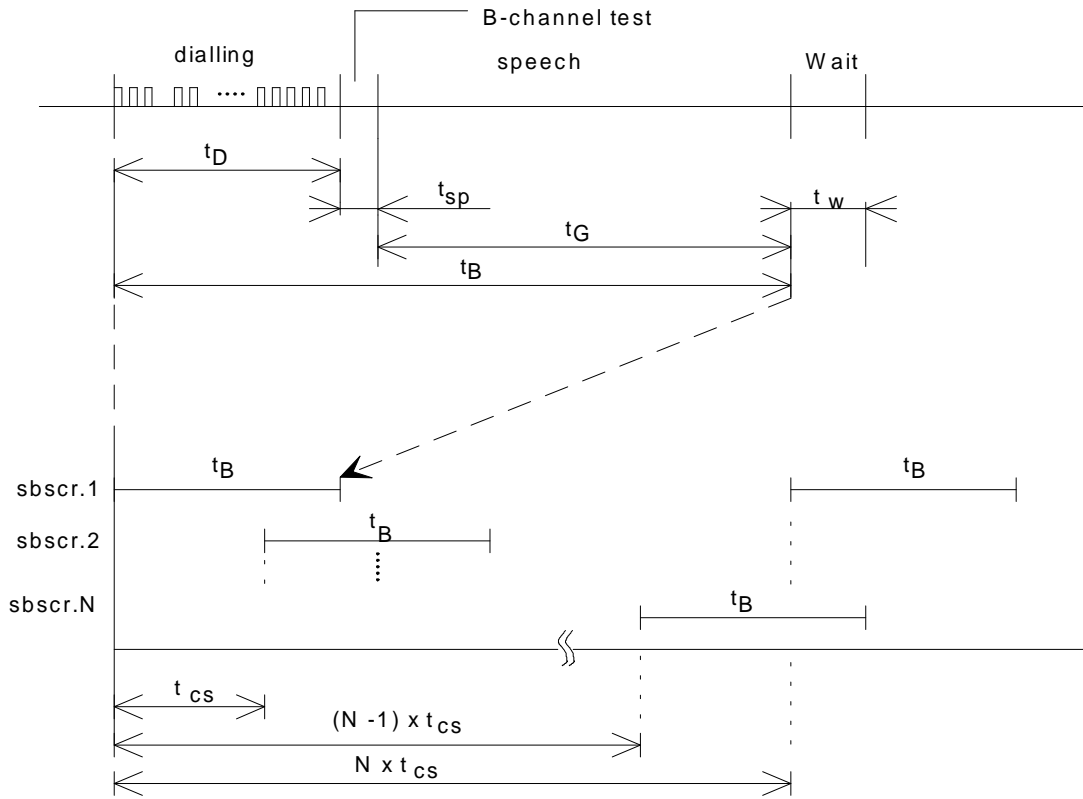

Figure C.4: Holding cycle of the call generator

Essentially, a seizure t_B consists of the dialling time t_D , shorter wait time for sound signal recognition t_{sp} etc. as well as of speech duration t_G . A wait time t_w then follows until the next theoretically possible call on this channel. During investigations the call generators are adjusted in such a way that the incoming and outgoing connections change permanently on one call generator line pair. For a relatively short speech time the dialling time forms an essential part of the overall call duration. For this reason for tests with a short call duration, for which the call duration is important, i.e. in the case of concentrating interfaces, it should be considered that the dialling time does not occur in incoming connections and thus a correction of the call duration of the outgoing connection (a half dialling time reduction) will be necessary. The connections are started in succession (within the call separation time). If several call generators are used, the generators will be interlinked.

The call separation time to be adjusted results in:

$$t_{cs} = \frac{3600 \text{ s}}{C_{BHCA}} \quad \text{(equation 6)}$$

with:

$$t_B = t_D + t_{sp} + t_G \quad \text{(equation 7)}$$

according to equation 5 in:

$$t_{cs} = \frac{2 t_B}{y_T^{xn}} \quad \text{(equation 8)}$$

C.2.4.3 Test evaluation

For practical reasons the load tests are exclusively done on the basis of PSTN subscribers. In the practical AN trials with the V_{5.1}, each interface was tested first with 360 BHCA of the outgoing traffic and 360 BHCA of the incoming traffic. These tests were performed over a few days. When evaluating the test results the number of connection errors was considered. During regular signal processing principally no connection errors occur, (the type of which is determined in the call generator protocol). If a few errors

(less than 1 ‰) occurred, these proved to be call generator errors or individual unit errors. Initiated by the AN manufacturers on the basis of the call duration reduction a multiple of the BHCA test values was adjusted as required by the DTAG. Thus it can be proved that the message processing within the AN surely fulfils the demands required by all AN suppliers.

Until now it was not possible to investigate systems with V_{5,2} interfaces, since these systems have not yet been available. But load tests at a concentrating interface with one 2 048 kbit/s link following the V_{5,2} concept, were performed. For this interface the LE manufacturer gave a maximum traffic value. In accordance with the average holding time of 90 s the BHCA value was calculated, on the basis of which the load tests were performed. After the tests with the given traffic value the message load was increased by reducing the call duration. This test was also successful.

C.3 Message delay considerations

C.3.1 Introduction

If a line is directly operated at the LE, all events take place in the LE during a connection. With the introduction of the AN in which own protocols proceed between the subscriber and LE, the situation changes totally as follows:

- events previously processed in the LE will now completely be processed in the AN (e.g. recognition and evaluation of loop signals);
- the conversion of events into V_{5,x} messages and vice versa is completely added;
- further internal AN conversions, e.g. of V_{5,x} messages into CAS signals are also added;
- data stream delays by inserting cross connectors and the electrical to optical to electrical conversion in the AN transmission part also occur;
- for the concentrating interfaces additional time is needed for the B-channel allocation during the call set-up.

For the direct connection of lines to the LE the transit time of call set-up messages is partially defined in the ITU-T Recommendation Q.543 [9]. But the AN insertion between the subscriber and LE partially results in changed conditions. On one hand the signal processing in the AN results in an additional delay time and on the other hand the functions and thus the execution time of the operations will be transferred from the LE to the AN. Thus, for example the logical time necessary for the recognition of a "hook flash" in the AN can be measured, (but this is not the case for the call set-up), since this function was excluded from the LE. This is the reason for the interest in determining which time is actually the result of the AN insertion and if the AN delays the message conversion further in the case of increased traffic load. This allows for conclusions of the AN behaviour under various operating conditions. Since the dynamic behaviour of the individual AN in the network is different and the various V_{5,x} realizations in the LE also show a different time behaviour, the network operator is interested in obtaining possibly complete information about the time behaviour of the newly added equipment of all occurring combinations in the network. One problem is to gain suitable measuring points to measure the message transit time between an event at the UNI and the receipt of a corresponding message at the V₅ interface. But a comparison with a directly connected subscriber cannot be done now, since there is no usable "measuring point" within the LE. Thus it is only possible to involve the NNI in the investigations. It is necessary to divide the investigations into three parts according to the objective aimed at (see figure 5):

- message transit time measurement between the AN user ports and the V_{5,x} (UNI→V₅, i.e. via the AN) (1);
- transit time measurement between the AN user ports and the #7 interface of the LE (UNI→#7, via the AN and LE) (2);
- comparison of the measuring values and the execution time of comparable events of directly connected user ports to the #7 interface (3).

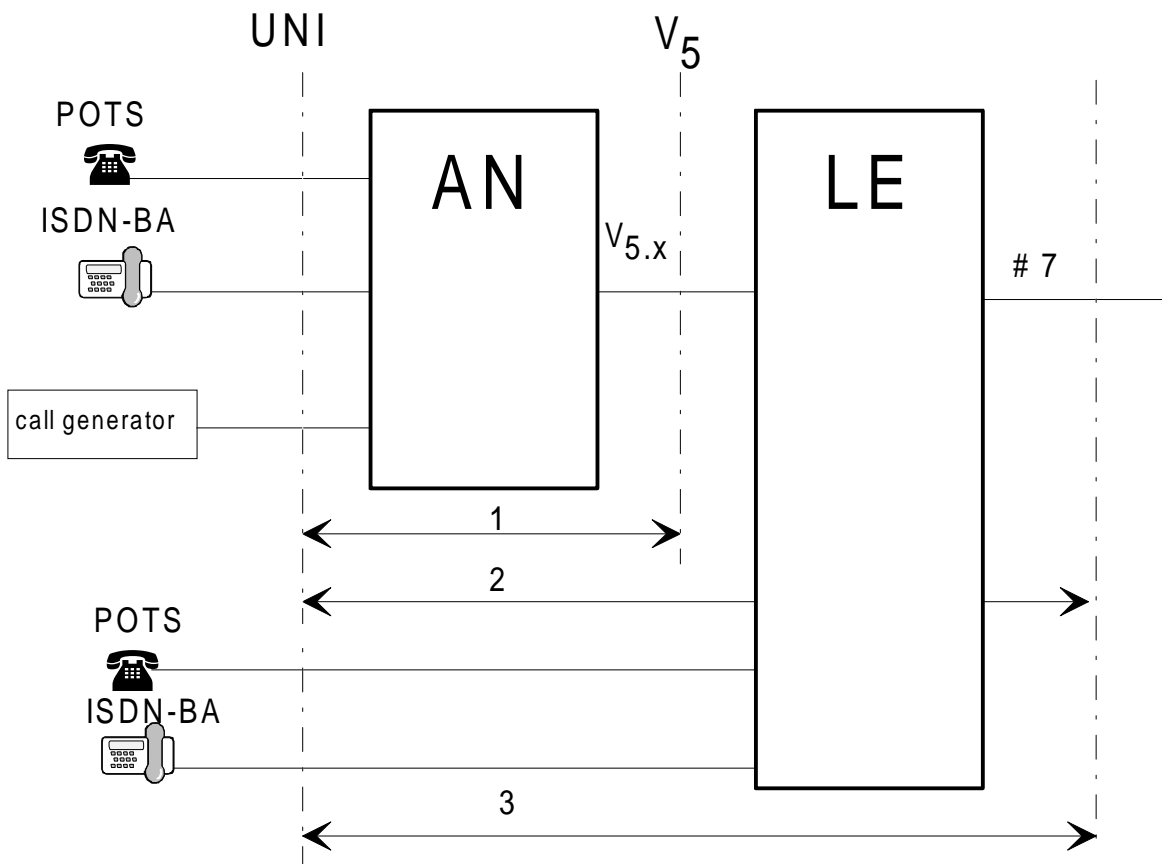

Figure C.5: measuring parts

In the first part the signal transit times affected by the AN are determined. With these results ANs can only be compared between each other and their dynamic behaviour with a changed traffic load can be characterized. For the investigations of the standard value observance these standard values should be determined for the AN or the AN should be evaluated by the comparison of the directly connected subscribers.

In the second part the transit time, which would have been additionally created by the AN for a real call set-up, is determined. For this purpose measurements of the whole part between the AN user ports and the LE #7 interface will be performed. The determined transit time can be compared with the ITU-T Recommendation Q.543 values.

Furthermore, the measurements will be performed under different external conditions:

- transit time measurement during the AN no-load running operation, i.e. without any additional traffic load;
- transit time measurement with a regular load according to part 2 or the simulation of overload events; but here it has to be guaranteed that the AN behaviour is observed, i.e. the LE has no load-limiting impact;
- all transit time measurements are performed in the increasing and decreasing traffic directions;
- measurements with increased system requirements within the AN according to part 4.

C.3.2 Definition of the trigger events

C.3.2.1 PSTN ports

Procedures related to the $V_{5,x}$ path structure are relevant especially if a B-channel has to be allocated ($V_{5,2}$) or those of the period in which resources to transmit the ringing voltage are free (incoming call set-up).

For further procedures in which line signals are converted into "SIGNAL" messages (dialling pulses or hook flash pulses) the pure signal transit time can be ignored from the recognition of a valid state change to the V_{5,x} message transmission.

Table C.4: trigger events for PSTN ports

outgoing call	UNI	V₅	#7
start trigger event	line_signal: off_hook		
stop trigger event		Message: ESTABLISH, steady signal: off hook	1)

incoming call	#7	V₅	UNI
start trigger event	1)	Message: ESTABLISH, pulsed signal: cadenced ringing	
stop trigger event			ringing tone is applied

C.3.2.2 ISDN-BA Ds-data

For the signal transit time consideration the procedures are only of importance during which layers at the S₀ or V_{5,x} are formed or removed.

Table C.5: trigger events for ISDN ports (Ds-data)

outgoing call	UNI	V₅	#7
start trigger event	access activation initiated by user (TE)		
stop trigger event		SABME, DL-request SETUP ACK. (from LE)	(note)
NOTE: #7 messages have not yet been selected.			

incoming call	#7	V₅	UNI
start trigger event	1)	ALERT (from LE)	
stop trigger event			access activated (from LE)

C.3.2.3 P-data in the D-channel (ISDN BA)

As for the Ds-data measurements for the transit time measurements of p-data the procedures are of importance during which layers at the S₀ or V_{5,x} are formed or removed. At present for the transit time determination of packets from the UNI to the packet data handler, sufficient experiences and measuring equipment necessary for the p-data traffic control are not available at this time by DTAG.

For these tests echo test equipment should be used allowing for the return of transmitted packets and thus the determination of the transit time "via all".

Table C.6: trigger events for ISDN ports (p-data)

	UNI (S₀)	V₅	UNI (S₀)
start trigger event	access activation initiated by user (TE)		
stop trigger event		SABME, DL-request	
start trigger event	transmitted packet (I-frame)		
stop trigger event			received packet (I-frame)

C.3.2.4 Trigger signal production

For the trigger signal production at the interfaces some special conditions have to be considered:

- Analogue interfaces: The most favourable approach is where the call simulator transmits a trigger signal when it generates or recognizes a line signal. If such equipment is not available, the trigger signal has to be derived from the concerned line signal externally by other equipment (e.g. oscilloscope).
- Digital interfaces: Although it will be necessary, it is difficult to trigger at the flag start or flag stop of messages. The available devices have a fixed, defined trigger time. The additionally generated time difference can be excluded after the measurement (message length \times frame clock = 15,625 ms).

C.3.3 Signal transit time test

The following figure shows the basic structure of a test configuration for the determination of the message transit time.

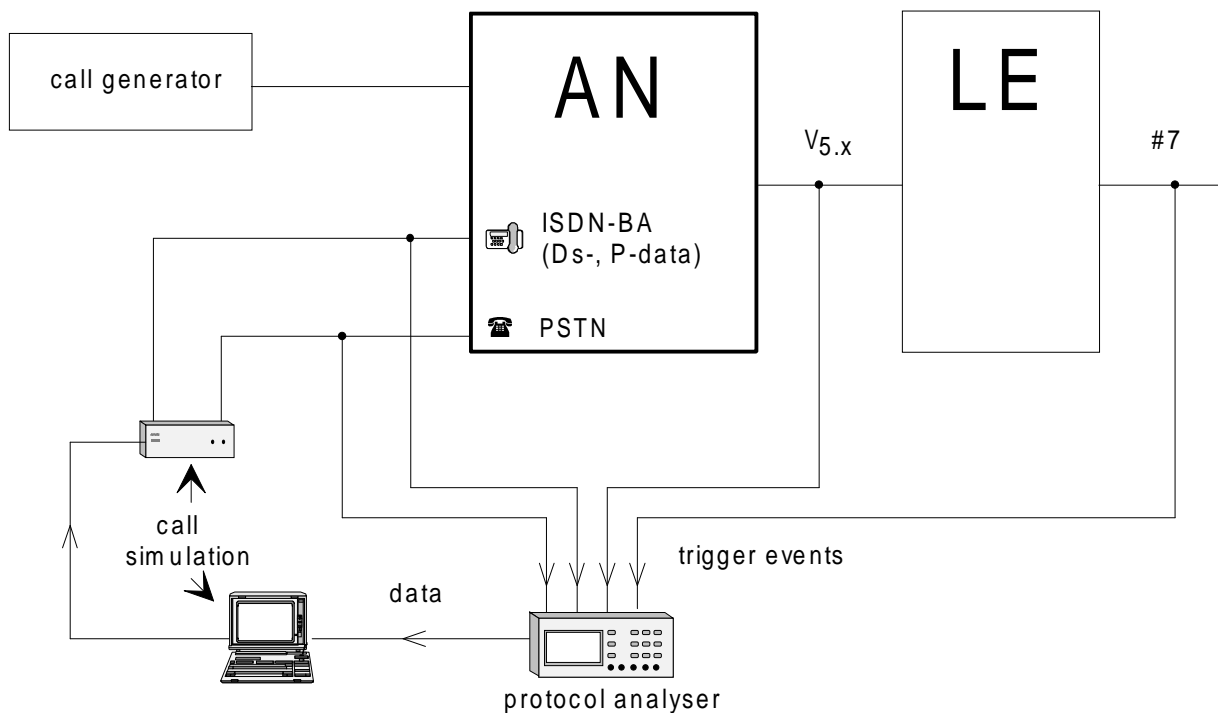

Figure C.6: Measuring set-up

C.3.3.1 Transit time within the AN

In the first part of the investigations the AN shall be considered as an independent unit. The aim is the transit time determination on the signal path via the AN between the user ports and the V_{5,x} interface. Thus the dynamic behaviour of the signal transit time via the AN can be determined independently, without the interference of other components.

C.3.3.2 Transit time via AN and LE

In this part of the measurements the characteristics being important for the practical usage of the AN shall be determined. The most important fact of the consideration is that with the AN further switching equipment is included into the overall call set-up. This results in the investigation objective of measuring the delay time which has effectively been **added** by the AN connection. The transit time measured from the AN user ports to the LE #7 interface serves as a value for the comparison with the transit time of ports directly connected to the LE (not via V_{5,x}).

C.3.4 Conclusions

For the measurements a protocol analyzer ETP 71 ® of the manufacturer GN Nettekst was used. The device is very suitable for the implementation of the measurement since events of analogue, ISDN-, V_{5,x}- and #7 interfaces can be recorded simultaneously. The simultaneous processing of different interface signals is the **basic** condition for a unique time basis. An analogue call simulator and an oscilloscope were used only for the generation of analogue trigger signals. The data given online from the ETP 71 was available in data base format and can be evaluated with some post-processing.

C.4 Abbreviations (used in annex C)

#7	Signalling System No.7
B-(channel)	bearer channel
BA	basic access
BHCA	busy hour call attempt
DTAG	Deutsche Telekom AG
IF	interface
ITU-T	International Telecommunications Union
NNI	network network interface
OPAL	"Optische Anschlußleitung" DTAG project name for optical subscriber line
P-(Data)	packet data
PBX	private branch exchange
PT(M)P	Point to (Multi-) Point
S ₀	ISDN subscriber interface 4-wire

C.5 Symbols (used in equations)

c_{BHCA}	number of seizures in the busy hour
k	number of PSTN lines
N	outgoing line number of the call generator
n	number of 2 048 kbit/s IF per TU
t_B	holding time of a test call
t_{CS}	call separation time
t_D	dialling time
t_G	speech time of a test call
t_m	average holding time
t_{SP}	time for B-channel test
t_W	wait time
$Y_{g(2M)}$	outgoing traffic via 2 048 kbit/s IF
$Y_{k(2M)}$	incoming traffic via 2 048 kbit/s IF
Y_T	overall traffic of a line in the busy hour
Y_{TG}	outgoing traffic of a line in the busy hour
Y_{Tk}	incoming traffic of a line in the busy hour

History

Document history	
November 1996	Public Enquiry PE 118: 1996-11-18 to 1997-03-14