



EUROPEAN
TELECOMMUNICATION
STANDARD

DRAFT
pr **ETS 300 784**

August 1996

Source: ETSI TC-SES

Reference: DE/SES-00020

ICS: 33.060.30

Key words: broadcasting, BSS, DTH, earth station, FSS, LNB, radio, receiver, RO, satellite, TV, TVRO

**Satellite Earth Stations and Systems (SES);
TeleVision Receive-Only (TVRO)
satellite earth stations operating in the
Fixed Satellite Service (FSS) and
Broadcasting Satellite Service (BSS)
11/12 GHz frequency bands**

ETSI

European Telecommunications Standards Institute

ETSI Secretariat

Postal address: F-06921 Sophia Antipolis CEDEX - FRANCE

Office address: 650 Route des Lucioles - Sophia Antipolis - Valbonne - FRANCE

X.400: c=fr, a=atlas, p=etsi, s=secretariat - **Internet:** secretariat@etsi.fr

Tel.: +33 92 94 42 00 - Fax: +33 93 65 47 16

Copyright Notification: No part may be reproduced except as authorized by written permission. The copyright and the foregoing restriction extend to reproduction in all media.

© European Telecommunications Standards Institute 1996. All rights reserved.

Contents

Foreword	5
1 Scope	7
2 Normative references	8
3 Definitions and abbreviations	8
3.1 Definitions	8
3.2 Abbreviations	9
4 Test report	9
5 Safety	9
5.1 Mechanical construction	9
5.2 Lightning protection	10
6 Radio Frequency (RF)	11
6.1 Local Oscillator (LO) frequency position	11
6.2 Frequency conversion tolerance	11
6.3 Radiation from the outdoor unit	11
6.4 Local Oscillator (LO) phase noise	13
6.5 Documentation	13
6.6 Radio Frequency (RF) input range	13
6.7 Intermediate Frequency (IF) output range	13
6.8 Figure of merit	15
6.9 Antenna sub-system	15
6.9.1 Frequency-band(s)	15
6.9.2 Polarisation	15
6.9.3 Co-polar on-axis gain	16
6.9.4 Antenna gain pattern	16
6.9.5 Cross-polarisation discrimination	18
6.9.6 Pointing accuracy capability	18
6.9.7 Antenna pointing and efficiency stability under severe environmental conditions	18
6.9.8 Linear polarisation plane alignment capability	19
6.9.9 Output interface of antenna sub-system	19
6.9.9.1 Physical interface	19
6.9.9.2 Impedance matching	19
6.10 Low-Noise Block (LNB) down-converter	20
6.10.1 RF input frequency range	20
6.10.2 IF output range	20
6.10.3 Frequency conversion tolerance	20
6.10.4 LNB noise temperature or noise figure	21
6.10.5 Image frequency rejection	21
6.10.6 Output level	21
6.10.7 Small signal gain	22
6.10.8 Linear distortions	22
6.10.9 LNB input interface	23
6.10.10 LNB output interface	23
6.10.10.1 Impedance	23
6.10.10.2 Type of connector	23
6.10.10.3 Return loss	23
7 Power supply	24
7.1 Power supply for LNB	24
7.2 Power supply for auxiliary devices	24

8	Commands and control functions.....	24
8.1	Commands via IF cable	25
8.1.1	Polarisation switching	25
8.1.2	Frequency band switching	25
8.1.3	Orbital position switching	25
8.1.4	Other commands and control functions.....	26
8.2	Switching by separate cable.....	26
Annex A (informative):	Protection ratio.....	27
Annex B (informative):	Dimensions in millimetres of waveguide flanges	28
B.1	Dimensions of Type B flanges in millimetres for ordinary rectangular waveguides	28
B.2	Dimensions of flanges in millimetres for circular waveguides.....	28
Annex C (normative):	Commands between indoor and outdoor unit using a 22 kHz carrier.....	29
History		30

Foreword

This draft European Telecommunication Standard (ETS) has been produced by the Satellite Earth Stations and Systems (SES) Technical Committee of the European Telecommunications Standards Institute (ETSI), and is now submitted for the Public Enquiry phase of the ETSI standards approval procedure.

The responsibilities between CENELEC and ETSI for the standardization of TVROs are shared according to the ETSI/CENELEC agreement.

Proposed transposition dates	
Date of latest announcement of this ETS (doa):	3 months after ETSI publication
Date of latest publication of new National Standard or endorsement of this ETS (dop/e):	6 months after doa
Date of withdrawal of any conflicting National Standard (dow):	6 months after doa

Blank page

1 Scope

This ETS gives the minimum technical characteristics specifications of satellite earth stations, capable of receiving audio-visual signals and distributed data.

The equipment considered in this ETS, is confined to the "outdoor unit" that consists of the antenna with the feed and the low-noise amplifier with its associated down-converter, referred to as Low-Noise Block (LNB) converter.

The output interface towards the indoor unit is defined at the LNB output connector. Consequently the coaxial cable link to the "indoor unit", the Intermediate Frequency (IF) amplifier and the demodulator are not covered by this ETS.

This ETS is applicable to earth stations which receive audio-visual signals and distributed data in the Fixed Satellite Services (FSS) frequency bands (10,70 to 11,70 GHz and 12,50 to 12,75 GHz) and in the Broadcast Satellite Services (BSS) frequency band (11,70 to 12,50 GHz).

The earth station may be capable of receiving from a single or from two/more orbital locations by means of either:

- motorised antenna; or
- LNB which allows the reflector or feed to be re-pointed along the orbital arc; or
- fixed reflector with a multiple-feed system whereby each feed is pointed towards a different position on the orbital arc.

This is referred to as "multiple-feed" in this ETS.

TeleVision Receive-Only (TVRO) earth stations are classified in two different types according to the corresponding services:

Type A for collective reception, in particular:

- cable distribution head-ends: Community Antenna TeleVision (CATV);
- community reception systems: Master Antenna TeleVision (MATV).

Type B for individual reception, i.e. Direct-To-Home (DTH) equipment.

This ETS makes clear distinction, wherever applicable, between Type A and Type B equipment specification.

The received television signals can be analogue or digital, all with the associated TV sound, and possibly other audio programmes.

EMC specifications are contained in EN 50083-2 [2], EN 55013 [7] and EN 55020 [6].

Safety specifications are contained in EN 50083-1 [1] and in clause 5 of this ETS.

This ETS deals with two types of specifications:

- a) specifications made:
 - to protect other users of the frequency spectrum (both satellite and terrestrial) from unacceptable interference;
 - for structural safety;
 - for lightning protection;
 - for protection from harmful interference.
- b) specifications:
 - related to the quality of reception;
 - to assist manufacturers to harmonise equipment design;
 - to enable equipment distributors and end-users to better determine equipment performance.

NOTE: These specifications apply if required by the manufacturer.

2 Normative references

This ETS incorporates by dated or undated references, provisions from other publications. These normative references are cited at the appropriate places in the text and the publications are listed hereafter. For dated references, subsequent amendments to, or revisions of any of these publications apply to this ETS only when incorporated in it by amendment or revision. For undated references the latest edition of the publication referred to applies.

- [1] EN 50083-1 (1993): "Cabled distribution systems for television and sound signals; Part 1: Safety requirements".
- [2] EN 50083-2 (1995): "Cabled distribution systems for television and sound signals; Part 2: Electromagnetic compatibility for equipment".
- [3] CISPR No. 16-1 (1993): "Specifications for radio interference measuring apparatus and measurements methods; Part 1: Radio disturbance and immunity measuring apparatus".
- [4] a) IEC 154-2 (1980): "Part 2: Relevant specifications for flanges for ordinary rectangular waveguides".
b) IEC 154-4 (1969): "Part 4: Relevant specifications for flanges for circular waveguides".
- [5] IEC 1319-1 (1995): "Interconnections of satellite receiving equipment; Part 1: Europe".
- [6] EN 55020 (1994) + prA11 (1995): "Immunity from radio interference of broadcast receivers and associated equipment".
- [7] EN 55013 (1990) + prA13 (1995): "Limits and methods of measurement of radio disturbance characteristics of broadcast receivers and associated equipment".
- [8] ETS 300 457 (1995): "Satellite Earth Stations and Systems (SES); Test methods for TeleVision Receive-Only (TVRO) operating in the 11/12 GHz frequency bands".
- [9] ITU (1990): "Radio Regulations, Vol. 1, 2, 3".
- [10] prTBR 029 (1996): "Satellite Earth Stations and Systems (SES); TeleVision Receive-Only (TVRO) satellite earth stations operating in the 11/12 GHz frequency bands".

3 Definitions and abbreviations

3.1 Definitions

For the purposes of this ETS, the following definitions apply:

outdoor unit: Is the part of the TVRO intended to be installed outdoor as declared by the manufacturer or indicated in the user documentation. It normally comprises two main parts:

- a) The antenna sub-system which converts the incident radiation field into a guided wave. The antenna sub-system consists of:
 - main reflector, secondary reflectors (if any) and radiator;
 - feed network (which may include optional polarising devices) for receiving orthogonal polarisation in a simultaneous or exclusive way.

Instead of reflector(s) / feed network sub-system, other types of antennas may be used e.g. flat array antennas;

- b) The LNB(s), which may include an optional filter, is a device with very low internal noise. The LNB amplifies the received signals in the RF band and converts them to the IF band (often called as the 1st IF) for transmission to one or more indoor units. The indoor unit performs tuning, demodulation and decoding of the received signals.

NOTE: The installation equipment (means of attachment) is outside the scope of this ETS. However, the antenna structures and other components, directly mounted on the antenna and forming an integral part of it, are specified in this ETS. This includes, in particular, the antenna pointing facilities.

figure of merit of the outdoor unit (G/T): The ratio between the antenna sub-system on-axis Gain (G) and the outdoor unit total equivalent noise Temperature under clear sky conditions (T), referred to the same point of the antenna sub-system output.

lower band: The frequency range from 10,70 GHz to 11,70 GHz.

higher band: The frequency range from 11,70 GHz to 12,75 GHz.

unwanted radiation: Any radiation radiated by the outdoor unit.

3.2 Abbreviations

For the purposes of this ETS, the following abbreviations apply:

BSS	Broadcasting Satellite Service
CATV	Community Antenna TeleVision
DTH	Direct-To-Home
EIRP	Equivalent Isotropically Radiated Power
EMC	ElectroMagnetic Compatibility
FSS	Fixed Satellite Service
G/T	Gain/noise Temperature (figure of merit of the outdoor unit)
IF	Intermediate Frequency
LNB	Low Noise Block (down converter)
LO	Local Oscillator
MATV	Master Antenna TeleVision system
PWK	Pulse Width Keyed
QPSK	Quadrature Phase Shift Keying (4-PSK)
RF	Radio Frequency
RLR	Return Loss Ratio
SMA (TV)	Satellite Master Antenna (TeleVision)
TTL	Transistor Transistor Logic
TV	TeleVision
TVRO	TeleVision Receive-Only

4 Test report

The test report shall be as specified in ETS 300 457 [8] and shall contain:

- the result of the test;
- all operational conditions and parameters.

5 Safety

5.1 Mechanical construction

Purpose:

Protection of operating personnel, the public and goods from insecure structures.

Specification:

The outdoor unit, including mounted and structural components (but excluding the means of attachment), shall be designed to support the following main loads due to:

- the weight of the antenna and structural components;
- the wind speed.

Loading due to snow and ice is not considered.

For the purpose of establishing outdoor unit loading (W), the following pressure values shall be used:

- a) Outdoor unit installed up to 20 m above ground level:
 - wind pressure (p) shall be assumed to be 800 Pascal (wind speed 130 km/h);
- b) Outdoor unit installed higher than 20 m above ground level:
 - wind pressure (p) shall be assumed to be 1 100 Pascal (wind speed 150 km/h).

The wind load is given by the formula: $W = c \times p \times A$, where:

- W is the wind load in Newton (N);
- c is the area correction coefficient ($c = 1,2$);
- p is the wind pressure in Pascal (Pa);
- A is the component area (m^2).

NOTE: Where adverse environmental conditions apply, a higher wind pressure value may need to be assumed, e.g.:

- wind pressure 1 250 Pascal (wind speed 160 km/h);
- wind pressure 1 900 Pascal (wind speed 200 km/h).

Up to the maximum applicable wind speed, referred to standard atmosphere temperature and pressure (293 K and $1,013 \times 10^6$ Pascal), none of the components shall be torn away.

The maximum installation height of the antenna and the maximum wind speed shall be those declared by the manufacturer. These limits shall be indicated in the data sheet of the test report and in the user's information leaflet (see subclause 6.5).

Verification:

For Specification 1:

The test method specified in subclause 5.2 of ETS 300 457 [8] shall apply.

The mechanical loads at the interface of the attachment device, shall be entered as values in the data sheet of the test report.

5.2 Lightning protection

Purpose:

To avoid dangerous potential differences between the outdoor unit and any other conductive structure.

Specification:

Means shall be provided to permit the attachment of bonding conductors of dimension indicated in subclause 10.2.3 of EN 50083-1 [1].

Verification:

The test method specified in subclause 5.7 of ETS 300 457 [8] shall apply.

6 Radio Frequency (RF)

6.1 Local Oscillator (LO) frequency position

Purpose:

To ensure compatibility with the sense of modulation required by the indoor unit.

Specification:

The RF spectrum of a signal received by the outdoor unit shall not be inverted at the outdoor unit output.

Verification:

The test method specified in subclause 6.1.5 of ETS 300 457 [8] shall apply.

6.2 Frequency conversion tolerance

Purpose:

To allow the indoor unit to perform correct channel selection and automatic frequency control.

Specification:

The conversion frequency (i.e. the difference between the frequency of an input signal and the output frequency of that signal) shall not deviate by more than ± 5 MHz from its nominal value with the following factors taken into account:

- a) temperature variations: in the range -20° C to $+55^{\circ}$ C;
- b) supply voltage variations: as stated by the manufacturer;
- c) LO setting error: as stated by the manufacturer;
- d) ageing.

The deviation of the conversion frequency from the nominal value due to a) and b) above shall together not exceed ± 3 MHz.

Verification:

The test method specified in subclause 6.1.5 of ETS 300 457 [8] shall apply.

6.3 Radiation from the outdoor unit

Purpose:

To limit the unwanted radiation level from the outdoor unit in order to protect the radio spectrum.

Specification 1: Unwanted radiation including LO leakage radiated from the antenna

The power of the unwanted radiation, including the LO frequency as well as its second harmonic, measured at the antenna flange (including the polarizer, ortho-mode transducer, band-pass filter, RF waveguides) shall not exceed the following limits, see TBR 029 [10]:

- - 60 dBm in a 120 kHz bandwidth at the fundamental frequency of the LO;
- - 50 dBm in a 120 kHz bandwidth at the second harmonic of the LO; and
- - 60 dBm in any other 120 kHz bandwidth.

This specification applies to the frequency range from 2,5 GHz to 25 GHz.

Verification:

The test method specified in subclause 6.2 in ETS 300 457 [8] shall apply.

Specification 2: Radiation from the outdoor unit (EIRP)

In accordance with the specification in EN 50083-2 [2] the Equivalent Isotropically Radiated Power (EIRP) of unwanted signals radiated by the outdoor unit within the band from 30 MHz to 25 GHz, shall not exceed the following values measured in any 120 kHz bandwidth (see CISPR No. 16-1 [3]):

- 20 dBpW in the range 30 MHz to 960 MHz;
- 43 dBpW in the range from 960 MHz to 2,5 GHz;
- 57 dBpW in the range from 2,5 GHz to 25 GHz.

The lower limits apply at the transition frequency.

This specification applies for all off-axis angles greater than 7°.

Specification 3: Radiation from the outdoor unit (EIRP)

This specification applies if required by the manufacturer.

The EIRP of unwanted signals radiated by the outdoor unit within the band from 30 MHz to 25 GHz, shall not exceed the following values measured in any 120 kHz bandwidth (see CISPR No. 16-1 [3]):

- 20 dBpW in the range 30 MHz to 960 MHz;
- 43 dBpW in the range from 960 MHz to 2,50 GHz;
- 45 dBpW in the range from 2,50 GHz to 10,70 GHz;
- 51 dBpW in the range from 10,70 GHz to 21,20 GHz;
- 57 dBpW in the range from 21,20 GHz to 25 GHz.

The lower limits apply at the transition frequency.

This specification applies for all off-axis angles greater than 7°.

Verification:

The test method in subclause 6.3 of ETS 300 457 [8] shall apply.

6.4 Local Oscillator (LO) phase noise

This specification applies if required by the manufacturer.

Purpose:

To allow the transmission of QPSK modulated signals with bit rates above about 20 Mbit/s.

Specification:

The phase noise of the LO shall be below the following limits:

- -50 dBc/Hz at 1 kHz;
- -75 dBc/Hz at 10 kHz;
- -95 dBc/Hz at 100 kHz.

Verification:

To be defined.

6.5 Documentation

Purpose:

To assist manufacturers to harmonised equipment design and to enable equipment distributors and end-users to better determine equipment performance and assist in the installation of the equipment.

Specification:

This specification applies if required by the manufacturer.

The manufacturer shall supply with each equipment an information leaflet, which contains the information listed in table 1. Items which are considered to be essential information for the end-user are indicated by an asterisk (*) in table 1.

6.6 Radio Frequency (RF) input range

Purpose:

To enable reception of signals transmitted in the 11/12 GHz bands.

Specification:

This specification applies if required by the manufacturer.

The outdoor unit shall be able to receive simultaneously signals in the frequency range from 10,70 GHz to 12,75 GHz.

Verification:

The test method specified in subclause 6.1.4 of ETS 300 457 [8] shall apply.

6.7 Intermediate Frequency (IF) output range

Purpose:

To ensure compatibility with the indoor unit input frequency range.

Specification:

Table 1: Contents of the information leaflet

- Antenna sub-system	Reference for measurement
<ul style="list-style-type: none"> - Mechanical characteristics <ul style="list-style-type: none"> - Antenna pointing accuracy and stability - Polarisation - Installation instructions * - Wind speed ratings - Mechanical loads transmitted from the outdoor unit to the attachment devices - Attachment plan 	<ul style="list-style-type: none"> see subclauses 6.9.6 and 6.9.7 see subclause 6.9.2 see subclause 5.1 see subclause 5.1
<ul style="list-style-type: none"> - Radio Frequency (RF) interface <ul style="list-style-type: none"> - Radio Frequency (RF) bands * - Type of polarisation * - Co-polar on-axis gain - Antenna receive gain pattern - Cross-polarisation discrimination 	<ul style="list-style-type: none"> see subclause 6.6 see subclause 6.9.2 see subclause 6.9.3 see subclause 6.9.4 see subclause 6.9.5
<ul style="list-style-type: none"> - Output interface (if this interface can be reached) of waveguide flange <ul style="list-style-type: none"> - Type of waveguide flange 	<ul style="list-style-type: none"> see subclause 6.10.9
<ul style="list-style-type: none"> - Power supply for auxiliary devices (actuator motor) <ul style="list-style-type: none"> - Voltage, polarity, current 	<ul style="list-style-type: none"> see subclause 7.2
- LNB	
<ul style="list-style-type: none"> - Input interface (if this interface can be reached) <ul style="list-style-type: none"> - Type of waveguide flange * - Radio Frequency (RF) input range(s) * - Noise figure (temperature) - Image frequency rejection 	<ul style="list-style-type: none"> see subclause 6.10.9 see subclause 6.10.1 see subclause 6.10.4 see subclause 6.10.5
<ul style="list-style-type: none"> - Transfer characteristics <ul style="list-style-type: none"> - LO frequency * - Frequency conversion tolerance - Small signal gain - Amplitude - frequency characteristic - Group delay characteristics 	<ul style="list-style-type: none"> see subclause 6.1 see subclause 6.2 see subclause 6.10.7 see subclause 6.10.8 see subclause 6.10.8
<ul style="list-style-type: none"> - Intermediate frequency output interface <ul style="list-style-type: none"> - Intermediate Frequency (IF) output range - Output maximum level - Type of connector - Impedance - Return loss - Power supply for the LNB <ul style="list-style-type: none"> - Voltage, polarity, current - Power supply for commands (switching of LO, switching of polarisation...) <ul style="list-style-type: none"> - Voltage, polarity, current 	<ul style="list-style-type: none"> see subclause 6.10.2 see subclause 6.10.6 see subclause 6.10.10.2 see subclause 6.10.10.1 see subclause 6.10.10.2 see subclause 7.1 see subclause 6.10.4
Commands and Control	
see subclause 8	
- Outdoor unit - Global quality	
- Figure of merit (G/T)	see subclause 6.8

This specification applies if required by the manufacturer.

The IF at the LNB output shall be in the range from 950 MHz to 2 150 MHz, or parts thereof.

NOTE: This specification is based on current technology and does not exclude improved equipment designs which allow a wider IF range.

Verification:

The test method specified in subclause 6.1.6 of ETS 300 457 [8] shall apply.

6.8 Figure of merit

Purpose:

To allow qualitative comparisons between different outdoor units.

Specification:

This specification applies if required by the manufacturer.

The value across the frequency band (see subclause 6.6) of the outdoor unit figure of merit shall be entered in the user's information leaflet, for 10° and 30° elevation angles.

Verification:

The test method in subclause 6.6 in ETS 300 457 [8] shall apply.

6.9 Antenna sub-system

All specifications for the antenna sub-system in subclause 6.9 apply if required by the manufacturer.

6.9.1 Frequency-band(s)

Purpose:

To enable reception of signals transmitted in the 11/12 GHz bands.

Specification:

The antenna subsystem shall be able to receive signals in the frequency bands from 10,70 GHz to 12,75 GHz.

Verification:

The test method specified in subclause 6.1.4 of ETS 300 457 [8] shall apply.

6.9.2 Polarisation

Purpose:

To enable the reception of signals in the 11/12 GHz band transmitted by satellites as linearly or circularly polarised waves.

Specification:

The antenna sub-system shall be designed to receive a linearly or circularly polarised electromagnetic field. For reception of linear polarised signals the two orthogonal polarisation may be received. For the case of circular polarised signals the right and left hand polarised fields may be received, although simultaneous reception of both polarisations is not necessary.

Verification:

The user's information leaflet shall state the type of polarisation employed and if single or dual polarisation is employed.

6.9.3 Co-polar on-axis gain

Purpose:

To allow the choice of the antenna sub-system in accordance with the wanted signal level.

Specification:

The antenna co-polar on-axis gains shall be indicated in the information leaflet, expressed in dB relative to an isotropic source (dBi), for the specified range(s) of frequency, and for the two polarisation types.

Verification:

The test method specified in subclause 6.5.2 of ETS 300 457 [8] shall apply.

6.9.4 Antenna gain pattern

General:

This subclause applies only to Type A equipment, the applicable specification for Type B equipment is under consideration.

Purpose:

To give a certain degree of protection of the wanted signals from interference from terrestrial services and from other satellites.

Specification 1:

At any frequency within the antenna sub-system receive frequency range(s) the gain $G(\theta)$ in dB relative to an isotropic antenna shall not exceed the following limits:

For FSS:

- $29 - 25 \log \theta$ for $2,80^\circ \leq \theta \leq 7^\circ$
- $+ 8$ for $7^\circ < \theta \leq 9,20^\circ$
- $32 - 25 \log \theta$ for $9,20^\circ < \theta \leq 30^\circ$
- -5 for $30^\circ < \theta \leq 70^\circ$
- 0 for $70^\circ < \theta$

For BSS:

- $29 - 25 \log \theta$ for $4,80^\circ \leq \theta \leq 7^\circ$
- $+ 8$ for $7^\circ < \theta \leq 9,20^\circ$
- $32 - 25 \log \theta$ for $9,20^\circ < \theta \leq 30^\circ$
- -5 for $30^\circ < \theta \leq 70^\circ$
- 0 for $70^\circ < \theta$

Specification 2:

At any frequency within the antenna sub-system receive frequency range(s) the cross-polar gain $G(\vartheta)$ expressed in dB relative to an isotropic antenna shall not exceed:

For FSS:

- $19 - 25 \log \vartheta$ for $2,80^\circ \leq \vartheta \leq 7^\circ$
- -2 for $7^\circ < \vartheta \leq 9,20^\circ$

For BSS:

- $19 - 25 \log \vartheta$ for $4,80^\circ \leq \vartheta \leq 7^\circ$
- -2 for $7^\circ < \vartheta \leq 9,20^\circ$

where ϑ is the angle in degrees between the main beam axis and the direction considered.

Design objective for FSS:

The antenna discrimination, defined as the difference between the on-axis gain and the gain at an angular offset, ϑ , should be at least 28 dB for values of ϑ greater than or equal to $2,80^\circ$, see annex A.

Design objective for BSS:

Antenna discrimination:

Type A equipment:

At any frequency within the antenna sub-system receive frequency range, the antenna discrimination, defined as the difference between the on-axis gain and the gain at an angular offset, ϑ , should be at least 27 dB for values of $\vartheta \geq 4,8$, see ITU Radio Regulations [9].

Antenna gain pattern:

Type B equipment:

a) Co-polar gain.

At any frequency within the antenna sub-system receive frequency range, the co-polar gain pattern $G(\vartheta)$ expressed in dB relative to an isotropic antenna should not exceed the following limits:

- $29 - 25 \log \vartheta$ for $4,8 < \vartheta \leq 11$
- $+3$ for $11 < \vartheta$

b) Cross polar gain.

At any frequency within the antenna sub-system receive frequency range, the cross-polar gain pattern $G(\vartheta)$ expressed in dB relative to an isotropic antenna should not exceed the following limits:

- $11 - 25 \log \vartheta$ for $4,8 < \vartheta \leq 7$

Verification:

The test method specified in subclause 6.5.3 of ETS 300 457 [8] shall apply.

6.9.5 Cross-polarisation discrimination

Purpose:

To give a certain degree of protection of the wanted signals from interference from cross-polarised signals.

Specification:

At any frequency within the antenna sub-system receive bandwidth, the receive cross-polarisation discrimination everywhere within the main beam down to -1 dB contour shall be at least:

- 25 dB for Type A equipment;
- 22 dB for Type B equipment.

Design objective for linear polarisation:

The design objective within the -1 dB contour shall be a cross-polarisation discrimination of:

- 30 dB for Type A equipment;
- 27 dB for Type B equipment.

Design objective for circular polarisation:

At any frequency within the antenna sub-system receive frequency range, the receive cross-polarisation discrimination everywhere within the main beam down to -1 dB contour, shall be at least:

- 28 dB for Type A equipment;
- 25 dB for Type B equipment.

Verification:

The test method in subclause 6.5.4 in ETS 300 457 [8] shall apply.

6.9.6 Pointing accuracy capability

Purpose:

To enable a accurate pointing of the antenna to the wanted satellite at the installation in order to provide the best possible reception of the wanted signal and to better avoid interference from signals transmitted on other satellites.

Specification:

The antenna sub-system alignment facilities shall enable the main beam axis to be adjusted and fixed with an accuracy of 10% of the antenna main beam minimum half power beam-width.

Verification:

The test method specified in subclause 6.5.5 in ETS 300 457 [8] shall apply.

6.9.7 Antenna pointing and efficiency stability under severe environmental conditions

Purpose:

Under severe environmental conditions, the pointing of the main lobe of the antenna and the shape of the reflector can be temporarily modified. Consequently, limits shall be given for the pointing and efficiency decrease of the antenna system.

Specification:

After application of 100 km/h max. wind speed, with gusts of 130 km/h, the installation shall not show any sign of permanent distortion or loss of components and should not suffer a de-pointing greater than the pointing accuracy, as specified in subclause 6.9.6.

Verification:

The test method specified in subclause 6.5.7 in ETS 300 457 [8] shall apply.

6.9.8 Linear polarisation plane alignment capability

Purpose:

To enable reception of signals with different linear polarisation an accurate match of the receive antenna polarisation plane to the wanted satellite transmit polarisation plane shall be performed (in order to take advantage of the antenna system polarisation isolation so as to protect the wanted signals from interference of signals transmitted on the orthogonal polarisation on the same or on a co-located satellite).

Specification 1:

The receive polarisation plane of the antenna system shall at least be continuously adjustable in a range of 180°.

Specification 2:

It shall be possible to fix the receive polarisation plane of the antenna system with an error of less than 1°.

Verification:

The test method specified in subclause 6.5.6 in ETS 300 457 [8] shall apply.

6.9.9 Output interface of antenna sub-system

6.9.9.1 Physical interface

Purpose:

Harmonisation of the antenna sub-system output interface with the LNB input.

Specification:

If a physical interface exists between the antenna sub-system and the LNB, and if waveguide is employed, then the flange shall be type UBR 120, (rectangular), or C 120 without gasket groove (circular) as indicated in IEC 154-2 and 154-4 [4] (see annex B).

Verification:

The test method specified in subclause 6.9 of ETS 300 457 [8] shall apply.

6.9.9.2 Impedance matching

Purpose:

To limit the mismatching between the antenna subsystem and the LNB and the resulting alterations of the frequency response (amplitude and group delay) at the user outlet.

Specification:

The impedance matching of the antenna sub-system, expressed in terms of Return Loss Ratio (RLR) (L, in dB) shall not be worse than the value declared by the manufacturer.

Verification:

The test method specified in subclause 6.9 of ETS 300 457 [8] shall apply.

6.10 Low-Noise Block (LNB) down-converter

All specifications in subclause 6.10 apply if required by the manufacturer.

The outdoor unit may be equipped with one or several LNBS and it is sometimes necessary to switch the output of the LNBS to the IF cable leading to the indoor unit, depending on whether reception is necessary from the higher or lower frequency bands, the orbital position of the wanted satellite in the case of a multiple-feed system or from linear horizontal or vertical to left or right circular polarisation.

The input of the LNB down-converter is connected to the output waveguide flange of the antenna feed or an equivalent point in the case of flat-array antennas.

6.10.1 RF input frequency range

Purpose:

To enable reception of signals transmitted in the 11/12 GHz bands.

Specification:

The outdoor unit shall be able to receive simultaneously signals in the frequency range from 10,70 GHz to 12,75 GHz.

Verification:

The test method specified in subclause 6.1.4 of ETS 300 457 [8] shall apply.

6.10.2 IF output range

Purpose:

To ensure compatibility with the indoor unit input frequency range.

Specification:

The IF at the LNB output shall be in the range from 950 MHz to 2 150 MHz, or parts thereof.

NOTE: This specification is based on current technology and does not exclude improved equipment designs which allow a wider IF range.

Verification:

The test method specified in subclause 6.1.6 of ETS 300 457 [8] shall apply.

6.10.3 Frequency conversion tolerance

Purpose:

To allow the indoor unit to perform correct channel selection and automatic frequency control.

Specification:

The conversion frequency (i.e. the difference between the frequency of an input signal and the output frequency of that signal) shall not deviate by more than ± 5 MHz from its nominal value with the following factors taken into account:

- a) temperature variations: in the range -20 C to +55 C;
- b) supply voltage variations: as stated by the manufacturer;
- c) LO setting error: as stated by the manufacturer;
- d) ageing.

The deviation of the conversion frequency from the nominal value due to a) and b) above shall together not exceed ± 3 MHz.

Verification:

The test method specified in subclause 6.1.5 of ETS 300 457 [8] shall apply.

6.10.4 LNB noise temperature or noise figure

Purpose:

To allow the correct choice of the LNB, in accordance with the wanted G/T.

Specification:

The worst case of the LNB noise temperature, or noise figure value over the RF input frequency range(s) shall be entered in the manufacturer's information leaflet.

Verification:

The test method specified in subclause 6.1.7 in ETS 300 457 [8] shall apply.

6.10.5 Image frequency rejection

Purpose:

With a LO frequency lower than the received frequency, the image frequency lies in a spectrum region allocated to maritime radar and other high-power navigation systems. Protection is necessary against the resulting interference.

Specification:

The LNB shall suppress the image frequencies of the received channel by at least 40 dB.

NOTE: If an optional filter is included, the image frequency rejection should be at least 80 dB.

Verification:

The test method specified in subclause 6.1.9 in ETS 300 457 [8] shall apply.

6.10.6 Output level

The LNB shall be able to amplify and down convert simultaneously several signals keeping signal distortion and intermodulation below acceptable levels.

Purpose:

To ensure a correct input level for the indoor unit.

Specification:

The maximum aggregate output level shall be specified at a signal to intermodulation ratio of 35 dB.

Verification:

The test method specified in subclause 6.1.11.3 in ETS 300 457 [8] shall apply.

6.10.7 Small signal gain

Purpose:

To ensure a correct signal level at the input of the indoor unit.

Specification:

The small signal gain of the LNB at any frequency within its RF input frequency range(s) (see subclause 6.6) shall be in the range of 40 dB to 65 dB. The measured small signal gain range shall be indicated in the manufacturers information leaflet.

Verification:

The test method specified in subclause 6.1.10 in ETS 300 457 [8] shall apply.

6.10.8 Linear distortions

Purpose:

The LNB shall be able to amplify and frequency down-convert simultaneously several signals keeping signal distortion at acceptable levels.

Specification 1: Amplitude-frequency characteristic

The amplitude variation over the IF frequency range (see subclause 6.10.2) shall not exceed the following maximum amplitude variation:

- 1,5 dB within any 27 MHz bandwidth;
- 2 dB within any 36 MHz bandwidth;
- 5 dB over the entire IF frequency range for Type A;
- 8 dB over the entire IF frequency range for Type B.

Verification:

The test method specified in subclause 6.1.11.1 in ETS 300 457 [8] shall apply.

Specification 2: Group-delay characteristic

The maximum permitted group-delay variation over the IF frequency range (see subclause 6.10.2) shall not exceed:

- 20 ns within any 36 MHz bandwidth.

Verification:

The test method specified in subclause 6.1.11.1 in ETS 300 457 [8] shall apply.

6.10.9 LNB input interface

Purpose:

Harmonisation of the LNB input interface with the antenna sub-system output.

Specification:

If a physical interface exists between the antenna sub-system and the LNB and if waveguide is employed, then the flange shall be type PBR 120 or C 120 with gasket groove, as indicated in IEC 154 [4], (see annex B).

Verification:

The test method specified in subclause 6.1.12.1 in ETS 300 457 [8] shall apply.

6.10.10 LNB output interface

6.10.10.1 Impedance

Purpose:

To define the electrical interface between the outdoor unit and the cable connecting it to the indoor unit.

Specification:

The value of the nominal output impedance shall be 50 Ω or 75 Ω for Type A and 75 Ω for Type B.

Verification:

The test method specified in subclause 6.1.12.2 in ETS 300 457 [8] shall apply.

6.10.10.2 Type of connector

Purpose:

To define the mechanical interface between the outdoor unit and the cable connecting it to the indoor unit.

Specification:

The connector should be "N" female or "SMA" type for 50 Ω impedance, and "F" female for 75 Ω impedance.

Verification:

The test method specified in subclause 6.1.12.3 of ETS 300 457 [8] shall apply.

6.10.10.3 Return loss

Purpose:

To ensure a correct impedance matching at the output of the outdoor unit.

Specification:

The output return loss over the IF frequency range(s) employed shall be as follows:

- better than 15 dB, for "N" or "SMA" connectors;
- better than 8 dB, for "F" connector.

Verification:

The test method specified in subclause 6.1.12.4 of ETS 300 457 [8] shall apply

7 Power supply

All specifications in clause 7 apply if required by the manufacturer.

7.1 Power supply for LNB

Purpose:

To define the characteristics of the power needed to supply the LNB. This will be useful to interface outdoor units with indoor units coming from different manufacturers.

Specification:

The LNB shall have a dc supply. Its characteristics shall be the following:

- voltage: from 11,50 to 19 V;
- polarity ground: negative;
- maximum current: up to 300 mA per LNB.

Verification:

The test method specified in subclause 6.1.3 in ETS 300 457 [8] shall apply.

7.2 Power supply for auxiliary devices

Purpose:

The most important auxiliary device may be the actuator motor for a motorised antenna. In this case an external power supply and control unit for the actuator motor shall be considered.

Specification:

The power supply for the actuator motor shall comply with the characteristics stated in IEC 1319-1 [5].

Verification:

To be defined.

8 Commands and control functions

All specifications in clause 8 apply if required by the manufacturer.

Commands may be transmitted from the indoor to the outdoor unit to switch the mode of reception and confirmation of the actual switched mode may be required at the indoor unit. Switching may be required to select:

- the frequency bands, either by switching the LO or the LNB used;
- vertical or horizontal polarisation;
- right hand circular or left hand circular polarisation;
- linear or circular polarisation;
- the orbital location, when a multiple feed system is used.

Switching may be performed either via the IF cable between the LNB output and the indoor unit or by means of a separate cable. Switching may be performed by means of dc voltage or by using a 22 kHz continuous tone or Pulse Width Keyed (PWK) 22 kHz carrier on the IF cable (see in annex C the basic characteristics of a PWK format presently under development). The exact nature of these signals is to be defined (the structure of the commands will be defined by another standardization body).

For compatibility consult IEC 1319-1 [5].

Purpose:

To define the characteristics of signals needed for the switching. This shall be necessary to interface outdoor units and indoor units coming from different manufacturers.

Specification:

Commands signals may be conveyed either by the IF cable or a separate cable.

8.1 Commands via IF cable

8.1.1 Polarisation switching

a) dc voltage switching

A nominal dc voltage of 13 V in the range 11,5 to +14 V (e.g. for vertical polarisation or right hand circular polarisation).

A nominal dc voltage of 17 V in the range 16 to +19 V (e.g. for horizontal polarisation or left hand circular polarisation).

b) Use of modulated 22 kHz carrier

A 22 kHz carrier with PWK commands (e.g. vertical or horizontal, linear or circular).

8.1.2 Frequency band switching

a) Use of an un-modulated 22 kHz carrier

Reception of the lower band - no carrier present.

Reception of the higher band - continuous 22 kHz carrier present.

NOTE: Present equipment use 22 kHz carrier for one or the other function depending on the type of installation.

b) Use of a modulated 22 kHz carrier

A 22 kHz carrier with PWK commands to switch between higher and lower bands.

8.1.3 Orbital position switching

a) Use of an un-modulated 22 kHz carrier

Reception of one orbital position - no carrier present,

Reception of a second orbital position - continuous 22 kHz carrier present.

NOTE: Present equipment use 22 kHz carrier for one or the other function depending on the type of installation.

b) Use of a modulated 22 kHz carrier

A 22 kHz carrier with PWK commands to switch between LNBS receiving from different orbital locations. In the case of a motorised system, a 22 kHz carrier with PWK commands to control the alignment towards the orbital arc.

8.1.4 Other commands and control functions

A 22 kHz carrier with PWK commands may be used for various switching and control functions as may be required in the future, for example:

- multiple IF cable switches;
- communication of data from the outdoor unit to the indoor unit (e.g. the actual local oscillator frequency of the LNB);
- IF frequency information in the case of community reception systems.

8.2 Switching by separate cable

- a) Magnetic polarisation switching by means of a current in the range -50 mA to +100 mA.
- b) Mechanical polarisation switching using a TTL interface.

Verification:

The test method specified in subclause 6.7.2 in ETS 300 457 [8] shall apply.

Annex A (informative): Protection ratio

The protection ratio is defined as the minimum permissible power ratio of the wanted to unwanted signals, usually expressed in dB, available at the receiver input, required to produce a specified grade of picture (or sound) impairment.

The levels of the wanted and unwanted signals depend on the entire satellite system, but the characteristics of the outdoor receiving antenna usually constitute a major factor. The results of extensive measurements show that the protection ratio values considered acceptable in order to obtain an appropriate quality of picture and sound are as follows:

- for cable distribution and community reception: 23 dB (aggregate interference);
- for individual reception: 20 dB (aggregate interference).

These protection ratio limits determine the requirements on the antenna cross-polar performances (for the case of a cross-polar, frequency offset carrier transmitted from the same satellite), as well as the antenna co-polar off-axis gain (for the case of adjacent satellite interference).

The maximum single interference level should be 5 dB less than the aggregate interference level. This leads to the following level of protection ratio:

- for cable distribution: 28 dB (single interference);
- for individual reception: 25 dB (single interference).

The first value above determines the design objective given in subclause 6.9.4.

Annex B (informative): Dimensions in millimetres of waveguide flanges

B.1 Dimensions of Type B flanges in millimetres for ordinary rectangular waveguides

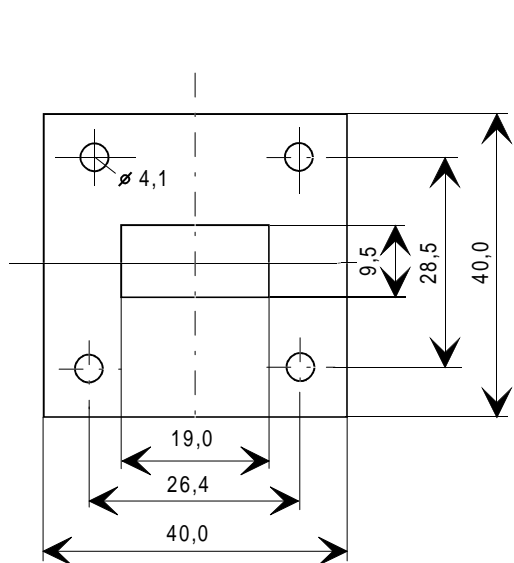

Figure B.1: UBR 120

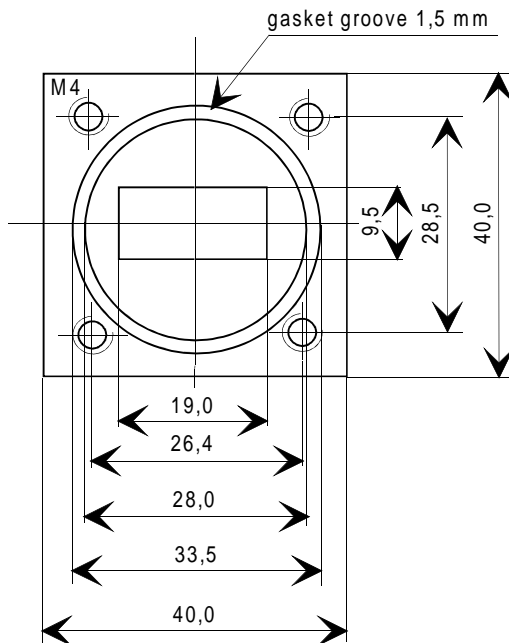

Figure B.2: PBR 120

B.2 Dimensions of flanges in millimetres for circular waveguides

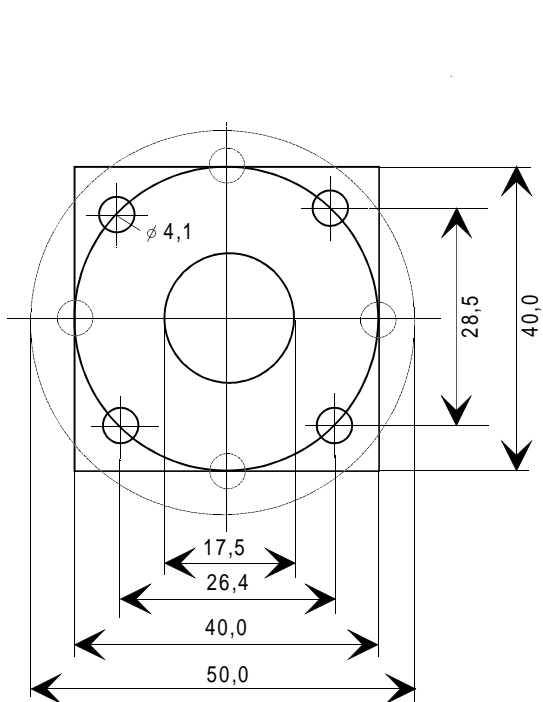

Figure B.3: C 120 without gasket groove

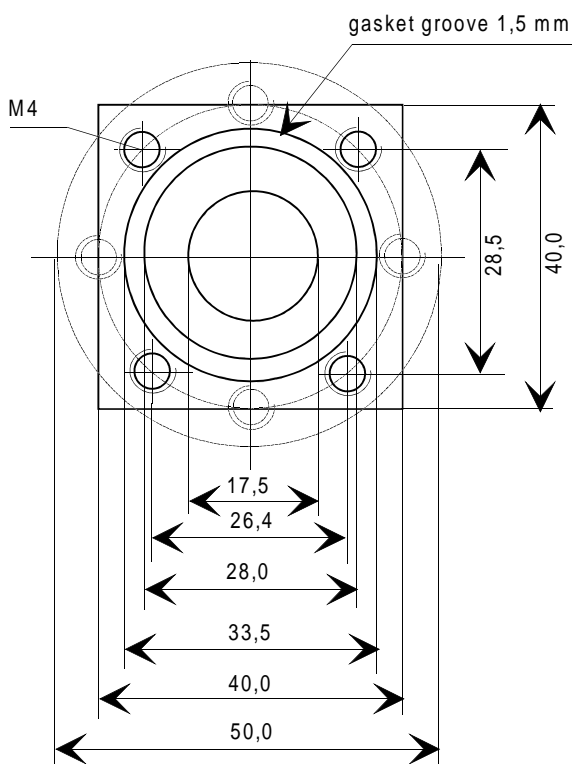

Figure B.4: C 120 with gasket groove

Annex C (normative): Commands between indoor and outdoor unit using a 22 kHz carrier

Formats of data bits and messages

A "zero" data bit is represented by a 1 ms burst of 22 kHz tone, followed by a 0,5 ms pause, and a "1" data bit is represented by a 0,5 ms tone burst followed by a 1 ms pause. The bits are arranged in groups of 9, the first 8 bits represent a byte and the final bit completes odd parity for the group. Each byte is transmitted with the most significant bit first and least significant bit last.

The basic command structure from the indoor to the outdoor unit consists of 3 bytes but messages can be of a variable number of bytes.

History

Document history	
August 1996	Public Enquiry PE 111: 1996-08-05 to 1996-11-29