



EUROPEAN
TELECOMMUNICATION
STANDARD

DRAFT
pr **ETS 300 771-6**

November 1997

Source: SPS

Reference: DE/SPS-05085-6

ICS: 33.020

Key words: B-ISDN, DSS2, UNI, layer 3, basic, testing, ATS, PIXIT, network

**Broadband Integrated Services Digital Network (B-ISDN);
Digital Subscriber Signalling System No. two (DSS2) protocol;
B-ISDN user-network interface layer 3
specification for point-to-multipoint call/bearer control;
Part 6: Abstract Test Suite (ATS) and partial Protocol
Implementation eXtra Information for Testing (PIXIT) proforma
specification for the network**

ETSI

European Telecommunications Standards Institute

ETSI Secretariat

Postal address: F-06921 Sophia Antipolis CEDEX - FRANCE

Office address: 650 Route des Lucioles - Sophia Antipolis - Valbonne - FRANCE

X.400: c=fr, a=atlas, p=etsi, s=secretariat - **Internet:** secretariat@etsi.fr

Tel.: +33 4 92 94 42 00 - Fax: +33 4 93 65 47 16

Copyright Notification: No part may be reproduced except as authorized by written permission. The copyright and the foregoing restriction extend to reproduction in all media.

© European Telecommunications Standards Institute 1997. All rights reserved.

Contents

Foreword	5
1 Scope	7
2 Normative references	7
3 Definitions and abbreviations	8
3.1 Definitions	8
3.2 Abbreviations	8
4 Abstract Test Method (ATM)	9
4.1 Description of ATM used	9
4.2 Conventions for test components and PCOs.....	9
5 Untestable test purposes.....	10
6 ATS to TP map.....	10
7 PCTR conformance.....	10
8 PIXIT conformance	11
9 ATS conformance	11
Annex A (normative): Protocol Conformance Test Report (PCTR) proforma.....	12
A.1 Identification summary	12
A.1.1 Protocol conformance test report.....	12
A.1.2 IUT identification	12
A.1.3 Testing environment	12
A.1.4 Limits and reservations.....	13
A.1.5 Comments	13
A.2 IUT Conformance status	13
A.3 Static conformance summary.....	13
A.4 Dynamic conformance summary.....	13
A.5 Static conformance review report.....	14
A.6 Test campaign report	14
A.7 Observations	30
Annex B (normative): Partial PIXIT proforma.....	31
B.1 Identification summary	31
B.2 Abstract test suite summary	31
B.3 Test laboratory	31
B.4 Client (of the test laboratory)	32
B.5 System Under Test (SUT).....	32

B.6	Protocol information.....	33
B.6.1	Protocol identification	33
B.6.2	Configuration to be tested	33
B.6.3	Stimuli for the IUT	33
B.6.4	Test management timers	33
B.6.5	Parameter values	34
Annex C (normative):	Abstract Test Suite (ATS)	35
C.1	The TTCN Graphical form (TTCN.GR)	35
C.2	The TTCN Machine Processable form (TTCN.MP)	35
History		36

Foreword

This draft European Telecommunication Standard (ETS) has been produced by the Signalling Protocols and Switching (SPS) Technical Committee of the European Telecommunications Standards Institute (ETSI), and is now submitted for the Public Enquiry phase of the ETSI standards approval procedure.

This ETS is part 6 of a multi-part standard covering the Digital Subscriber Signalling System No. two (DSS2) protocol specification for the Broadband Integrated Services Digital Network (B-ISDN) signalling user-network layer 3 specification for point-to-multipoint call/bearer control, as described below:

- Part 1: "Protocol specification [ITU-T Recommendation Q.2971 (1995), modified]";
- Part 2: "Protocol Implementation Conformance Statement (PICS) specification proforma specification";
- Part 3: "Test Suite Structure and Test Purposes (TSS&TP) for the user";
- Part 4: "Abstract Test Suite (ATS) and partial Protocol Implementation eXtra Information for Testing (PIXIT) proforma specification for the user";
- Part 5: "Test Suite Structure and Test Purposes (TSS&TP) specification for the network";
- Part 6: "Abstract Test Suite (ATS) and partial Protocol Implementation eXtra Information for Testing (PIXIT) proforma specification for the network".**

Proposed transposition dates	
Date of latest announcement of this ETS (doa):	3 months after ETSI publication
Date of latest publication of new National Standard or endorsement of this ETS (dop/e):	6 months after doa
Date of withdrawal of any conflicting National Standard (dow):	6 months after doa

Blank page

1 Scope

This sixth part of ETS 300 771 specifies the network Abstract Test Suite (ATS) for the T_B reference point or coincident S_B and T_B reference point (as defined in ITU-T Recommendation I.413 [8]) of implementations conforming to the standards for the signalling user-network layer 3 specification for point-to-multipoint call/bearer control of the Digital Subscriber Signalling System No. two (DSS2) protocol for the pan-European Broadband Integrated Services Digital Network (B-ISDN), ETS 300 771-1 [1].

A further part of this ETS specifies the Test Suite Structure and Test Purposes (TSS&TP) related to this ATS and partial PIXIT proforma. Other parts specify the TSS&TP and the ATS and partial PIXIT proforma for the user side of the T_B reference point or coincident S_B and T_B reference point of implementations conforming to ETS 300 771-1 [1].

2 Normative references

This ETS incorporates by dated and undated reference, provisions from other publications. These normative references are cited at the appropriate places in the text and the publications are listed hereafter. For dated references, subsequent amendments to or revisions of any of these publications apply to this ETS only when incorporated in it by amendment or revision. For undated references the latest edition of the publication referred to applies.

- [1] ETS 300 771-1: "Broadband Integrated Services Digital Network (B-ISDN); Digital Subscriber Signalling System No. two (DSS2) protocol; B-ISDN user-network interface layer 3 specification for point-to-multipoint call/bearer control; Part 1: Protocol specification [ITU-T Recommendation Q.2971 (1995), modified]".
- [2] ETS 300 771-2: "Broadband Integrated Services Digital Network (ISDN); Digital Subscriber Signalling System No. two (DSS2) protocol; B-ISDN user-network interface layer 3 specification for point-to-multipoint call/bearer control; Part 2: Protocol Implementation Conformance Statement (PICS) proforma specification".
- [3] ISO/IEC 9646-1: "Information technology - Open System Interconnection - Conformance testing methodology and framework - Part 1: General concepts".
- [4] ISO/IEC 9646-2: "Information technology - Open System Interconnection - Conformance testing methodology and framework - Part 2: Abstract test suite specification".
- [5] ISO/IEC 9646-3: "Information Technology - OSI Conformance Testing Methodology and Framework; Part 3: The Tree and Tabular Combined Notation".
- [6] ISO/IEC 9646-4: "Information technology - Open System Interconnection - Conformance testing methodology and framework - Part 4: Test realization".
- [7] ISO/IEC 9646-5: "Information technology - Open System Interconnection Conformance testing methodology and framework, Part 5: Requirements on test laboratories and clients for the conformance assessment process".
- [8] ITU-T Recommendation I.413 (1993): "B-ISDN user-network interface".

3 Definitions and abbreviations

3.1 Definitions

For the purposes of this ETS, the following definitions apply:

Implementation Under Test (IUT): See ISO/IEC 9646-1 [3].

System Under Test (SUT): See ISO/IEC 9646-1 [3].

Abstract Test Suite (ATS): See ISO/IEC 9646-1 [3].

Protocol Implementation Conformance Statement (PICS): See ISO/IEC 9646-1 [3].

PICS proforma: See ISO/IEC 9646-1 [3].

Protocol Implementation Extra Information For Testing (PIXIT): See ISO/IEC 9646-1 [3].

PIXIT proforma: See ISO/IEC 9646-1 [3].

Lower Tester (LT): See ISO/IEC 9646-1 [3].

Upper Tester (UT): See ISO/IEC 9646-1 [3].

Point Of Control And Observation (PCO): See ISO/IEC 9646-1 [3].

3.2 Abbreviations

For the purposes of this ETS, the following abbreviations apply:

ATM	Abstract Test Method
ATS	Abstract Test Suite
B-ISDN	Broadband Integrated Services Digital Network
CM	Coordination Message
CP	Coordination Point
DSS2	Digital Subscriber Signalling System No. two
ExTS	Executable Test Suite
IUT	Implementation Under Test
LT	Lower Tester
MOT	Means Of Testing
MTC	Main Test Component
PCO	Point of Control and Observation
PCTR	Protocol Conformance Test Report
PDU	Protocol Data Unit
PICS	Protocol Implementation Conformance Statement
PIXIT	Protocol Implementation eXtra Information for Testing
PTC	Parallel Test Component
SUT	System Under Test
TCP	Test Co-ordination Procedures
TP	Test Purpose
TTCN	Tree and Tabular Combined Notation
UT	Upper Tester
TP	Test Purpose
TSS	Test Suite Structure

4 Abstract Test Method (ATM)

4.1 Description of ATM used

The requirement for testing the network IUT is to focus on the behaviour of the network IUT at the user-network interface where a T_B reference point or coincident S_B and T_B reference point applies. Thus the IUT is the network DSS2 protocol entity at a particular user-network interface and is not the whole network.

It is possible to specify an ATS based on a Single party (remote) test method for such an IUT. However, it is considered that an ATS based on such an approach is of limited use as the only way to specify IUT generated PDUs is to use the "implicit send" statement. Many users of such an ATS would replace the "implicit send" statements with descriptions of the behaviour at other interfaces.

An ATS based on a multi-party test method is considered to be more useful in that it is closer to how a real test suite would be constructed. Such a test method specifies behaviour at multiple network interfaces. One very important limitation here is that tests are focused on one particular interface. Thus the test system is made up one Main Test Component (MTC) and one or more Parallel Test Components (PTC), see figure 1.

4.2 Conventions for test components and PCOs

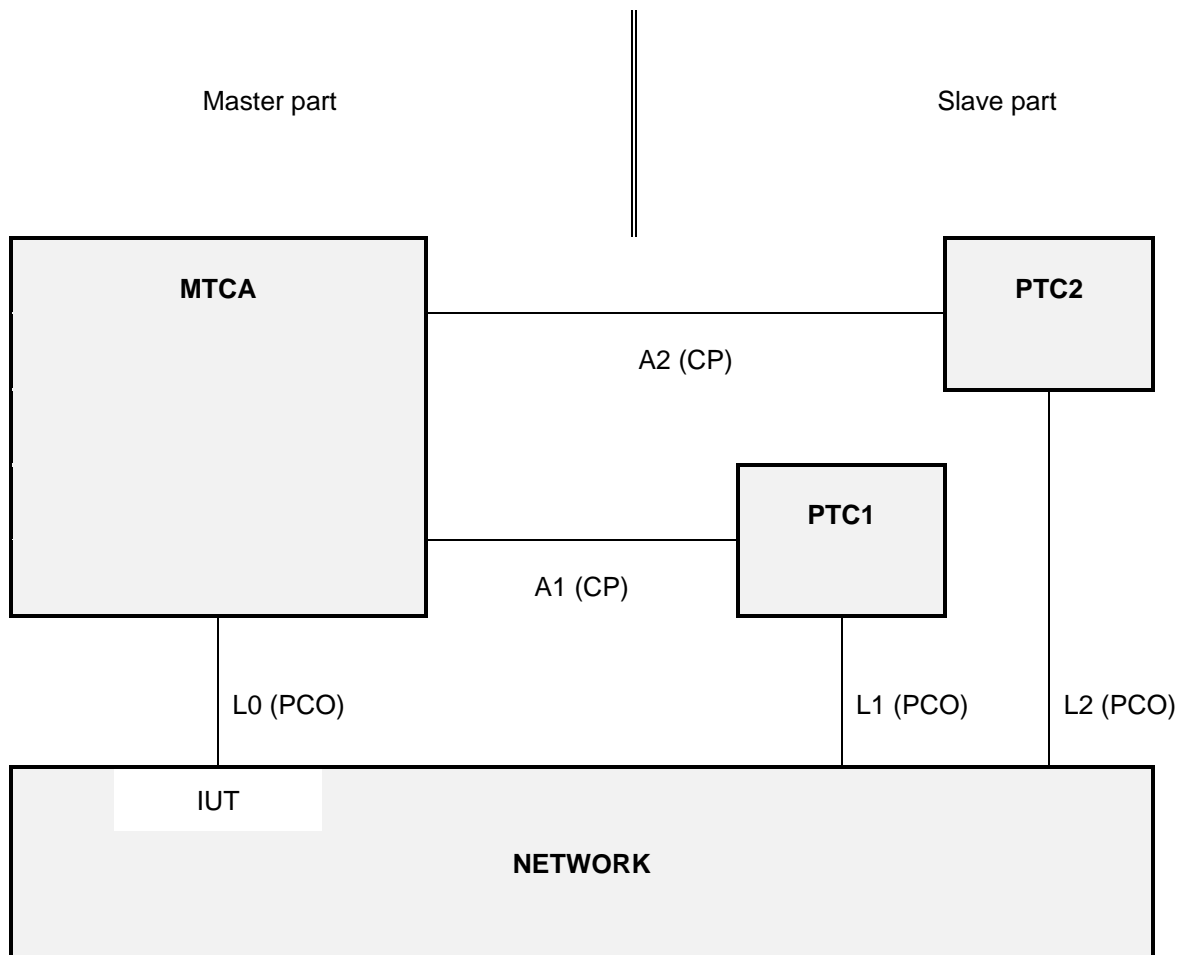

Figure 1: Multi-party test method

In a master/slave arrangement, the MTC is considered to be the master while the PTCs are the slaves. The "slave" testers are only an explicit description of how to deal with the remote interfaces during the testing process, i.e. "how to make the IUT send the required message".

This means, in particular, that the verdict will only be assigned from the protocol aspects observed on *the* interface under test (i.e. by the "master" tester), as it would be observed by a terminal connected to this interface. A failure in the correlation between the protocol at the different interfaces to which the different testers are connected, i.e. in the mechanism of the functional service itself, will not cause a FAIL verdict. For instance, if the IUT fails to send a message on the tested interface after another interface has received the proper stimulus, the verdict will be INCONCLUSIVE.

The MTC MTCA has two functions in this configuration. Firstly, it has the MTC function of controlling the one or more PTCs. Thus it is responsible for starting the PTCs and afterwards coordinates activities by exchanging Coordination Messages (CM) with the PTCs. Secondly it is responsible for the behaviour of the Lower Tester (LT) at PCO L0.

A combination of the remote and multi-party test methods is applied. As can be seen from figure 1, several Point of Control and Observations (PCOs) are used. All PCOs reside at the service access points between layers 2 and 3.

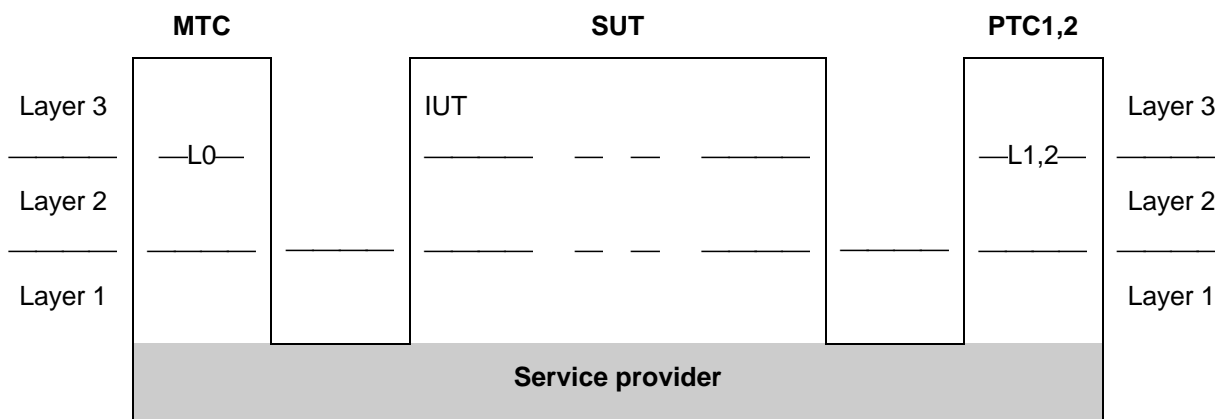

Figure 2: Combination of the remote and multi-party test methods

The MTC PCO is named "L0" ("L" for Lower). The L0 PCO is used to control and observe the behaviour of the IUT and test case verdicts are assigned depending on the behaviour observed at this PCO. The PTCs PTC1, PTC2 etc. use PCOs L1, L2 etc. These PCOs are used to control and, in a limited way, observe the behaviour of the network equipment at interfaces other than the one under test. No verdicts are assigned at these PCOs.

As stated in a previous paragraph, the non-receipt of network generated messages at L0, which are stimulated by events at the L1, L2 etc., will result in INCONCLUSIVE rather than FAIL verdicts being assigned.

PTC2 is only activated in that test cases that test the procedures at the access between a root user and the IUT, when more than one party is involved in the call between the root user and the IUT. In test cases which verify that the IUT rejects invalid or unacceptable SETUP messages, no PTC is activated at all, as these rejection procedures are considered local to the access between IUT and MTC.

5 Untestable test purposes

There are no untestable test purposes associated with this ATS.

6 ATS to TP map

The identifiers used for the TPs are reused as test case names. Thus there is a straightforward one-to-one mapping.

7 PCTR conformance

A test laboratory, when requested by a client to produce a Protocol Conformance Test Report (PCTR), is required, as specified in ISO/IEC 9646-5 [7], to produce a PCTR conformant with the PCTR template given in annex B of ISO/IEC 9646-5 [7].

Furthermore, a test laboratory, offering testing for the ATS specification contained in annex C, when requested by a client to produce a PCTR, is required to produce a PCTR conformant with the PCTR proforma contained in annex A of this ETS.

A PCTR which conforms to this PCTR proforma specification shall preserve the content and ordering of the clauses contained in annex A. Subclause A.6 of the PCTR may contain additional columns. If included, these shall be placed to the right of the existing columns. Text in italics may be retained by the test laboratory.

8 PIXIT conformance

A test realizer, producing an executable test suite for the Abstract Test Suite (ATS) specification contained in annex C, is required, as specified in ISO/IEC 9646-4 [6], to produce an augmented partial PIXIT proforma conformant with this partial PIXIT proforma specification.

An augmented partial PIXIT proforma which conforms to this partial PIXIT proforma specification shall, as a minimum, have contents which are technically equivalent to annex B. The augmented partial PIXIT proforma may contain additional questions that need to be answered in order to prepare the Means Of Testing (MOT) for a particular IUT.

A test laboratory, offering testing for the ATS specification contained in annex C, is required, as specified in ISO/IEC 9646-5 [7], to further augment the augmented partial PIXIT proforma to produce a PIXIT proforma conformant with this partial PIXIT proforma specification.

A PIXIT proforma which conforms to this partial PIXIT proforma specification shall, as a minimum, have contents which are technically equivalent to annex B. The PIXIT proforma may contain additional questions that need to be answered in order to prepare the test laboratory for a particular IUT.

9 ATS conformance

The test realizer, producing a MOT and Executable Test Suite (ExTS) for this ATS specification, shall comply with the requirements of ISO/IEC 9646-4 . In particular, these concern the realization of an ExTS based on each ATS. The test realizer shall provide a statement of conformance of the MOT to this ATS specification.

An ExTS which conforms to this ATS specification shall contain test groups and test cases which are technically equivalent to those contained in the ATS in annex C. All sequences of test events comprising an abstract test case shall be capable of being realized in the executable test case. Any further checking which the test system might be capable of performing is outside the scope of this ATS specification and shall not contribute to the verdict assignment for each test case.

Test laboratories running conformance test services using this ATS shall comply with ISO/IEC 9646-5 [7].

A test laboratory which claims to conform to this ATS specification shall use an MOT which conforms to this ATS.

Annex A (normative): Protocol Conformance Test Report (PCTR) proforma

Notwithstanding the provisions of the copyright clause related to the text of this ETS, ETSI grants that users of this ETS may freely reproduce the PCTR proforma in this clause so that it can be used for its intended purposes and may further publish the completed PCTR.

A.1 Identification summary

A.1.1 Protocol conformance test report

PCTR number:	
PCTR date:	
Corresponding SCTR number:	
Corresponding SCTR date:	
Test laboratory identification:	
Test laboratory manager:	
Signature:	

A.1.2 IUT identification

Name:	
Version:	
Protocol specification:	ETS 300 771 [1]
PICS:	
Previous PCTRs (if any):	

A.1.3 Testing environment

PIXIT reference number:	
ATS specification:	ETS 300 771-6
Abstract test method:	Multi-party test method (see ISO/IEC 9646-2)
Means of testing identification:	
Dates of testing:	
Conformance log reference(s):	
Retention date for log reference(s):	

A.1.4 Limits and reservations

Additional information relevant to the technical contents or further use of the test report, or to the rights and obligations of the test laboratory and the client, may be given here. Such information may include restriction on the publication of the report.

.....
.....
.....
.....

A.1.5 Comments

Additional comments may be given by either the client or the test laboratory on any of the contents of the PCTR, for example, to note disagreement between the two parties.

.....
.....
.....
.....

A.2 IUT Conformance status

This IUT has / has not been shown by conformance assessment to be non-conforming to the specified protocol specification.

Strike the appropriate words in this sentence. If the PICS for this IUT is consistent with the static conformance requirements (as specified in clause A.3 of this report) and there are no "FAIL" verdicts to be recorded (in clause A.6) strike the word "has", otherwise strike the words "has not".

A.3 Static conformance summary

The PICS for this IUT is / is not consistent with the static conformance requirements in the specified protocol.

Strike the appropriate words in this sentence.

A.4 Dynamic conformance summary

The test campaign did / did not reveal errors in the IUT.

Strike the appropriate words in this sentence. If there are no "FAIL" verdicts to be recorded (in clause A.6 of this report) strike the word "did", otherwise strike the words "did not".

Summary of the results of groups of tests:

.....
.....
.....
.....
.....

A.5 Static conformance review report

If clause A.3 indicates non-conformance, this subclause itemizes the mismatches between the PICS and the static conformance requirements of the specified protocol specification.

.....

.....

.....

.....

.....

.....

A.6 Test campaign report

ATS reference	Selected? (Y/N)	Run? (Y/N)	Verdict	Observations
Signalling procedures at the coincident S_B/T_B and at the T_B reference points				
L3MN_01_01				
L3MN_01_02				
L3MN_01_03				
L3MN_01_04				
L3MN_01_05				
L3MN_01_06				
L3MN_02_01				
L3MN_02_02				
L3MN_03_01				
L3MN_03_02				
L3MN_04_01				
L3MN_04_02				
L3MN_05_01				
L3MN_05_02				
L3MN_05_03				
L3MN_05_04				
L3MN_05_05				
L3MN_05_06				
L3MN_05_07				
L3MN_05_08				
L3MN_05_09				
L3MN_05_10				
L3MN_06_01				
L3MN_06_02				
L3MN_06_03				
L3MN_07_01				
L3MN_07_02				
L3MN_07_03				
L3MN_07_04				
L3MN_07_05				
L3MN_07_06				
L3MN_07_07				
L3MN_07_08				
L3MN_07_09				
L3MN_07_10				
L3MN_07_11				

(continued)

ATS reference	Selected? (Y/N)	Run? (Y/N)	Verdict	Observations
L3MN_07_12				
L3MN_07_13				
L3MN_07_14				
L3MN_07_15				
L3MN_07_16				
L3MN_07_17				
L3MN_07_18				
L3MN_07_19				
L3MN_07_20				
L3MN_07_21				
L3MN_07_22				
L3MN_07_23				
L3MN_07_24				
L3MN_07_25				
L3MN_07_26				
L3MN_07_27				
L3MN_07_28				
L3MN_07_29				
L3MN_07_30				
L3MN_07_31				
L3MN_07_32				
L3MN_07_33				
L3MN_07_34				
L3MN_07_35				
L3MN_07_36				
L3MN_07_37				
L3MN_07_38				
L3MN_07_39				
L3MN_07_40				
L3MN_07_41				
L3MN_08_01				
L3MN_08_02				
L3MN_08_03				
L3MN_08_04				
L3MN_08_05				
L3MN_08_06				
L3MN_08_07				
L3MN_08_08				
L3MN_08_09				
L3MN_09_01				
L3MN_09_02				
L3MN_09_03				
L3MN_09_04				
L3MN_09_05				
L3MN_09_06				
L3MN_09_07				
L3MN_09_08				
L3MN_09_09				
L3MN_09_10				
L3MN_10_01				
L3MN_10_02				
L3MN_10_03				
L3MN_10_04				
L3MN_10_05				
L3MN_10_06				
L3MN_10_07				

(continued)

ATS reference	Selected? (Y/N)	Run? (Y/N)	Verdict	Observations
L3MN_10_08				
L3MN_10_09				
L3MN_10_10				
L3MN_10_11				
L3MN_10_12				
L3MN_10_13				
L3MN_10_14				
L3MN_11_01				
L3MN_11_02				
L3MN_11_03				
L3MN_11_04				
L3MN_11_05				
L3MN_11_06				
L3MN_11_07				
L3MN_12_01				
L3MN_12_02				
L3MN_12_03				
L3MN_12_04				
L3MN_12_05				
L3MN_13_01				
L3MN_13_02				
L3MN_13_03				
L3MN_13_04				
L3MN_13_05				
L3MN_14_01				
L3MN_14_02				
L3MN_14_03				
L3MN_14_04				
L3MN_14_05				
L3MN_14_06				
L3MN_15_01				
L3MN_15_02				
L3MN_15_03				
L3MN_15_04				
L3MN_15_05				
L3MN_15_06				
L3MN_15_07				
L3MN_15_08				
L3MN_15_09				
L3MN_15_10				
L3MN_15_11				
L3MN_15_12				
L3MN_15_13				
L3MN_15_14				
L3MN_15_15				
L3MN_15_16				
L3MN_15_17				
L3MN_15_18				
L3MN_15_19				
L3MN_15_20				
L3MN_15_21				
L3MN_15_22				
L3MN_15_23				
L3MN_15_24				
L3MN_15_25				
L3MN_15_26				

(continued)

ATS reference	Selected? (Y/N)	Run? (Y/N)	Verdict	Observations
L3MN_15_27				
L3MN_15_28				
L3MN_15_29				
L3MN_15_30				
L3MN_15_31				
L3MN_15_32				
L3MN_15_33				
L3MN_15_34				
L3MN_15_35				
L3MN_16_01				
L3MN_16_02				
L3MN_16_03				
L3MN_16_04				
L3MN_16_05				
L3MN_16_06				
L3MN_16_07				
L3MN_16_08				
L3MN_16_09				
L3MN_16_10				
L3MN_16_11				
L3MN_16_12				
L3MN_16_13				
L3MN_16_14				
L3MN_16_15				
L3MN_16_16				
L3MN_16_17				
L3MN_16_18				
L3MN_16_19				
L3MN_16_20				
L3MN_16_21				
L3MN_16_22				
L3MN_16_23				
L3MN_16_24				
L3MN_16_25				
L3MN_16_26				
L3MN_16_27				
L3MN_16_28				
L3MN_16_29				
L3MN_16_30				
L3MN_16_31				
L3MN_16_32				
L3MN_16_33				
L3MN_16_34				
L3MN_16_35				
L3MN_16_36				
L3MN_16_37				
L3MN_16_38				
L3MN_16_39				
L3MN_16_40				
L3MN_16_41				
L3MN_16_42				
L3MN_16_43				
L3MN_16_44				
L3MN_16_45				
L3MN_17_01				
L3MN_17_02				

(continued)

ATS reference	Selected? (Y/N)	Run? (Y/N)	Verdict	Observations
L3MN_17_03				
L3MN_17_04				
L3MN_17_05				
L3MN_17_06				
L3MN_17_07				
L3MN_17_08				
L3MN_17_09				
L3MN_17_10				
L3MN_17_11				
L3MN_17_12				
L3MN_17_13				
L3MN_17_14				
L3MN_17_15				
L3MN_17_16				
L3MN_17_17				
L3MN_17_18				
L3MN_17_19				
L3MN_17_20				
L3MN_17_21				
L3MN_17_22				
L3MN_17_23				
L3MN_18_00				
L3MN_18_01				
L3MN_18_02				
L3MN_18_03				
L3MN_18_04				
L3MN_18_05				
L3MN_18_06				
L3MN_18_07				
L3MN_18_08				
L3MN_18_09				
L3MN_18_10				
L3MN_18_11				
L3MN_18_12				
L3MN_18_13				
L3MN_18_14				
L3MN_18_15				
L3MN_18_16				
L3MN_18_17				
L3MN_18_18				
L3MN_18_19				
L3MN_18_20				
L3MN_18_21				
L3MN_18_22				
L3MN_18_23				
L3MN_18_24				
L3MN_18_25				
L3MN_18_26				
L3MN_18_27				
L3MN_18_28				
L3MN_18_29				
L3MN_18_30				
L3MN_18_31				
L3MN_18_32				
L3MN_18_33				
L3MN_18_34				

(continued)

ATS reference	Selected? (Y/N)	Run? (Y/N)	Verdict	Observations
L3MN_18_35				
L3MN_19_01				
L3MN_19_02				
L3MN_19_03				
L3MN_19_04				
L3MN_19_05				
L3MN_19_06				
L3MN_19_07				
L3MN_19_08				
L3MN_19_09				
L3MN_19_10				
L3MN_19_11				
L3MN_19_12				
L3MN_19_13				
L3MN_19_14				
L3MN_19_15				
L3MN_19_16				
L3MN_19_17				
L3MN_19_18				
L3MN_19_19				
L3MN_19_20				
L3MN_20_01				
L3MN_20_02				
L3MN_20_03				
L3MN_20_04				
L3MN_20_05				
L3MN_20_06				
L3MN_20_07				
L3MN_20_08				
L3MN_20_09				
L3MN_20_10				
L3MN_20_11				
L3MN_20_12				
L3MN_21_01				
L3MN_21_02				
L3MN_21_03				
L3MN_21_04				
L3MN_21_05				
L3MN_21_06				
L3MN_21_07				
L3MN_21_08				
L3MN_21_09				
L3MN_21_10				
L3MN_21_11				
L3MN_21_12				
L3MN_22_01				
L3MN_22_02				
L3MN_22_03				
L3MN_22_04				
L3MN_22_05				
L3MN_22_06				
L3MN_22_07				
L3MN_22_08				
L3MN_22_09				
L3MN_22_10				
L3MN_22_11				

(continued)

ATS reference	Selected? (Y/N)	Run? (Y/N)	Verdict	Observations
L3MN_22_12				
L3MN_22_13				
L3MN_22_14				
L3MN_22_15				
L3MN_22_16				
L3MN_22_17				
L3MN_22_18				
L3MN_22_19				
L3MN_22_20				
L3MN_22_21				
L3MN_22_22				
L3MN_22_23				
L3MN_22_24				
L3MN_22_25				
L3MN_22_26				
L3MN_22_27				
L3MN_22_28				
L3MN_22_29				
L3MN_22_30				
L3MN_22_31				
L3MN_22_32				
L3MN_22_33				
L3MN_22_34				
L3MN_22_35				
L3MN_22_36				
L3MN_22_37				
L3MN_22_38				
L3MN_22_39				
L3MN_22_40				
L3MN_22_41				
L3MN_22_42				
L3MN_22_43				
L3MN_22_44				
L3MN_22_45				
L3MN_23_01				
L3MN_23_02				
L3MN_23_03				
L3MN_23_04				
L3MN_23_05				
L3MN_23_06				
L3MN_23_07				
L3MN_23_08				
L3MN_23_09				
L3MN_23_10				
L3MN_23_11				
L3MN_23_12				
L3MN_23_13				
L3MN_23_14				
L3MN_24_01				
L3MN_24_02				
L3MN_25_01				
L3MN_25_02				
L3MN_25_03				
L3MN_25_04				
L3MN_26_01				
L3MN_26_02				

(continued)

ATS reference	Selected? (Y/N)	Run? (Y/N)	Verdict	Observations
L3MN_26_03				
L3MN_26_04				
L3MN_26_05				
L3MN_26_06				
L3MN_26_07				
L3MN_26_08				
L3MN_27_01				
L3MN_27_02				
L3MN_27_03				
L3MN_27_04				
L3MN_27_05				
L3MN_27_06				
L3MN_27_07				
L3MN_27_08				
L3MN_27_09				
L3MN_27_10				
L3MN_27_11				
L3MN_27_12				
L3MN_28_01				
L3MN_28_02				
L3MN_28_03				
L3MN_28_04				
L3MN_28_05				
L3MN_28_06				
L3MN_28_07				
L3MN_28_08				
L3MN_28_09				
(continued)				

ATS reference	Selected? (Y/N)	Run? (Y/N)	Verdict	Observations
Procedures at the T_B reference point for interworking with private B-ISDNs				
L3MN_29_01				
L3MN_29_02				
L3MN_30_01				
L3MN_30_02				
L3MN_31_01				
L3MN_31_02				
L3MN_32_01				
L3MN_32_02				
L3MN_32_03				
L3MN_33_01				
L3MN_33_02				
L3MN_33_03				
L3MN_33_04				
L3MN_33_05				
L3MN_34_01				
L3MN_34_02				
L3MN_35_01				
L3MN_35_02				
L3MN_35_03				
L3MN_35_04				
L3MN_35_05				
L3MN_35_06				
L3MN_35_07				
L3MN_36_01				
L3MN_36_02				
L3MN_36_03				
L3MN_36_04				
L3MN_36_05				
L3MN_36_06				
L3MN_36_07				
L3MN_36_08				
L3MN_36_09				
L3MN_36_10				
L3MN_36_11				
L3MN_36_12				
L3MN_36_13				
L3MN_37_01				
L3MN_37_02				
L3MN_37_03				
L3MN_37_04				
L3MN_37_05				
L3MN_37_06				
L3MN_37_07				
L3MN_37_08				
L3MN_37_09				
L3MN_37_10				
L3MN_37_11				
L3MN_37_12				
L3MN_37_13				
L3MN_37_14				
L3MN_37_15				
L3MN_38_01				
L3MN_38_02				
L3MN_38_03				
L3MN_38_04				

(continued)

ATS reference	Selected? (Y/N)	Run? (Y/N)	Verdict	Observations
L3MN_38_05				
L3MN_39_01				
L3MN_39_02				
L3MN_39_03				
L3MN_39_04				
L3MN_39_05				
L3MN_40_01				
L3MN_40_02				
L3MN_40_03				
L3MN_40_04				
L3MN_40_05				
L3MN_40_06				
L3MN_40_07				
L3MN_40_08				
L3MN_40_09				
L3MN_40_10				
L3MN_40_11				
L3MN_40_12				
L3MN_40_13				
L3MN_40_14				
L3MN_40_15				
L3MN_40_16				
L3MN_40_17				
L3MN_40_18				
L3MN_40_19				
L3MN_40_20				
L3MN_40_21				
L3MN_40_22				
L3MN_40_23				
L3MN_40_24				
L3MN_40_25				
L3MN_40_26				
L3MN_40_27				
L3MN_40_28				
L3MN_40_29				
L3MN_40_30				
L3MN_40_31				
L3MN_40_32				
L3MN_40_33				
L3MN_40_34				
L3MN_40_35				
L3MN_40_36				
L3MN_40_37				
L3MN_40_38				
L3MN_40_39				
L3MN_40_40				
L3MN_40_41				
L3MN_40_42				
L3MN_40_43				
L3MN_40_44				
L3MN_40_45				
L3MN_40_46				
L3MN_40_47				
L3MN_40_48				
L3MN_40_49				
L3MN_40_50				

(continued)

ATS reference	Selected? (Y/N)	Run? (Y/N)	Verdict	Observations
L3MN_40_51				
L3MN_40_52				
L3MN_40_53				
L3MN_40_54				
L3MN_40_55				
L3MN_40_56				
L3MN_40_57				
L3MN_40_58				
L3MN_40_59				
L3MN_41_01				
L3MN_41_02				
L3MN_41_03				
L3MN_41_04				
L3MN_41_05				
L3MN_41_06				
L3MN_41_07				
L3MN_41_08				
L3MN_41_09				
L3MN_41_10				
L3MN_41_11				
L3MN_41_12				
L3MN_41_13				
L3MN_41_14				
L3MN_41_15				
L3MN_41_16				
L3MN_41_17				
L3MN_41_18				
L3MN_41_19				
L3MN_41_20				
L3MN_41_21				
L3MN_41_22				
L3MN_41_23				
L3MN_41_24				
L3MN_41_25				
L3MN_41_26				
L3MN_41_27				
L3MN_41_28				
L3MN_41_29				
L3MN_41_30				
L3MN_41_31				
L3MN_41_32				
L3MN_41_33				
L3MN_41_34				
L3MN_41_35				
L3MN_41_36				
L3MN_41_37				
L3MN_41_38				
L3MN_41_39				
L3MN_41_40				
L3MN_41_41				
L3MN_41_42				
L3MN_41_43				
L3MN_41_44				
L3MN_41_45				
L3MN_41_46				
L3MN_41_47				

(continued)

ATS reference	Selected? (Y/N)	Run? (Y/N)	Verdict	Observations
L3MN_41_48				
L3MN_41_49				
L3MN_41_50				
L3MN_41_51				
L3MN_41_52				
L3MN_41_53				
L3MN_41_54				
L3MN_41_55				
L3MN_41_56				
L3MN_41_57				
L3MN_41_58				
L3MN_41_59				
L3MN_41_60				
L3MN_41_61				
L3MN_41_62				
L3MN_41_63				
L3MN_41_64				
L3MN_41_65				
L3MN_41_66				
L3MN_41_67				
L3MN_41_68				
L3MN_41_69				
L3MN_41_70				
L3MN_41_71				
L3MN_41_72				
L3MN_41_73				
L3MN_41_74				
L3MN_41_75				
L3MN_41_76				
L3MN_41_77				
L3MN_41_78				
L3MN_41_79				
L3MN_42_01				
L3MN_42_02				
L3MN_42_03				
L3MN_42_04				
L3MN_42_05				
L3MN_42_06				
L3MN_42_07				
L3MN_42_08				
L3MN_42_09				
L3MN_42_10				
L3MN_42_11				
L3MN_42_12				
L3MN_42_13				
L3MN_42_14				
L3MN_42_15				
L3MN_42_16				
L3MN_42_17				
L3MN_42_18				
L3MN_42_19				
L3MN_42_20				
L3MN_42_21				
L3MN_42_22				
L3MN_42_23				
L3MN_42_24				

(continued)

ATS reference	Selected? (Y/N)	Run? (Y/N)	Verdict	Observations
L3MN_42_25				
L3MN_42_26				
L3MN_42_27				
L3MN_42_28				
L3MN_43_01				
L3MN_43_02				
L3MN_43_03				
L3MN_43_04				
L3MN_43_05				
L3MN_43_06				
L3MN_43_07				
L3MN_43_08				
L3MN_43_09				
L3MN_43_10				
L3MN_43_11				
L3MN_43_12				
L3MN_43_13				
L3MN_43_14				
L3MN_43_15				
L3MN_43_16				
L3MN_43_17				
L3MN_43_18				
L3MN_43_19				
L3MN_43_20				
L3MN_43_21				
L3MN_43_22				
L3MN_43_23				
L3MN_43_24				
L3MN_43_25				
L3MN_43_26				
L3MN_43_27				
L3MN_43_28				
L3MN_43_29				
L3MN_43_30				
L3MN_43_31				
L3MN_43_32				
L3MN_43_33				
L3MN_43_34				
L3MN_43_35				
L3MN_43_36				
L3MN_43_37				
L3MN_43_38				
L3MN_43_39				
L3MN_43_40				
L3MN_43_41				
L3MN_44_01				
L3MN_44_02				
L3MN_44_03				
L3MN_44_04				
L3MN_44_05				
L3MN_44_06				
L3MN_44_07				
L3MN_44_08				
L3MN_44_09				
L3MN_44_10				
L3MN_44_11				

(continued)

ATS reference	Selected? (Y/N)	Run? (Y/N)	Verdict	Observations
L3MN_44_12				
L3MN_44_13				
L3MN_44_14				
L3MN_44_15				
L3MN_44_16				
L3MN_45_01				
L3MN_45_02				
L3MN_45_03				
L3MN_45_04				
L3MN_45_05				
L3MN_45_06				
L3MN_45_07				
L3MN_45_08				
L3MN_45_09				
L3MN_45_10				
L3MN_45_11				
L3MN_45_12				
L3MN_46_01				
L3MN_46_02				
L3MN_46_03				
L3MN_46_04				
L3MN_46_05				
L3MN_46_06				
L3MN_46_07				
L3MN_46_08				
L3MN_46_09				
L3MN_46_10				
L3MN_46_11				
L3MN_46_12				
L3MN_47_01				
L3MN_47_02				
L3MN_47_03				
L3MN_47_04				
L3MN_47_05				
L3MN_47_06				
L3MN_47_07				
L3MN_47_08				
L3MN_47_09				
L3MN_47_10				
L3MN_47_11				
L3MN_47_12				
L3MN_47_13				
L3MN_47_14				
L3MN_47_15				
L3MN_47_16				
L3MN_47_17				
L3MN_47_18				
L3MN_47_19				
L3MN_47_20				
L3MN_47_21				
L3MN_47_22				
L3MN_47_23				
L3MN_47_24				
L3MN_47_25				
L3MN_47_26				
L3MN_47_27				

(continued)

ATS reference	Selected? (Y/N)	Run? (Y/N)	Verdict	Observations
L3MN_47_28				
L3MN_47_29				
L3MN_47_30				
L3MN_47_31				
L3MN_47_32				
L3MN_47_33				
L3MN_47_34				
L3MN_47_35				
L3MN_47_36				
L3MN_47_37				
L3MN_47_38				
L3MN_47_39				
L3MN_47_40				
L3MN_47_41				
L3MN_47_42				
L3MN_47_43				
L3MN_47_44				
L3MN_47_45				
L3MN_47_46				
L3MN_47_47				
L3MN_47_48				
L3MN_47_49				
L3MN_47_50				
L3MN_47_51				
L3MN_47_52				
L3MN_47_53				
L3MN_48_01				
L3MN_48_02				
L3MN_48_03				
L3MN_48_04				
L3MN_48_05				
L3MN_48_06				
L3MN_48_07				
L3MN_48_08				
L3MN_48_09				
L3MN_48_10				
L3MN_48_11				
L3MN_48_12				
L3MN_48_13				
L3MN_48_14				
L3MN_48_15				
L3MN_48_16				
L3MN_48_17				
L3MN_48_18				
L3MN_49_01				
L3MN_49_02				
L3MN_50_01				
L3MN_50_02				
L3MN_50_03				
L3MN_50_04				
L3MN_51_01				
L3MN_51_02				
L3MN_51_03				
L3MN_51_04				
L3MN_51_05				
L3MN_51_06				

(continued)

ATS reference	Selected? (Y/N)	Run? (Y/N)	Verdict	Observations
L3MN_51_07				
L3MN_51_08				
L3MN_52_01				
L3MN_52_02				
L3MN_52_03				
L3MN_52_04				
L3MN_52_05				
L3MN_52_06				
L3MN_52_07				
L3MN_52_08				
L3MN_52_09				
L3MN_52_10				
L3MN_52_11				
L3MN_52_12				
L3MN_53_01				
L3MN_53_02				
L3MN_53_03				
L3MN_53_04				
L3MN_53_05				
L3MN_53_06				
L3MN_53_07				
L3MN_53_08				
L3MN_53_09				

Annex B (normative): Partial PIXIT proforma

Notwithstanding the provisions of the copyright clause related to the text of this ETS, ETSI grants that users of this ETS may freely reproduce the PIXIT proforma in this clause so that it can be used for its intended purposes and may further publish the completed PIXIT.

B.1 Identification summary

PIXIT number:

.....

Test laboratory name:

.....

Date of issue:

.....

Issued to:

.....

B.2 Abstract test suite summary

Protocol specification: ETS 300 771-1

ATS specification: ETS 300 771-6

Abstract test method: Multi-party test method (see ISO/IEC 9646-2)

B.3 Test laboratory

Test laboratory identification:

.....

Accreditation status of the test service:

.....

Accreditation reference:

.....

Test laboratory manager:

.....

Test laboratory contact:

.....

Means of testing:

.....

Test laboratory instructions for completion:

.....

B.4 Client (of the test laboratory)

Client identification:

.....

Client test manager:

.....

Client contact:

.....

Test facilities required:

.....

B.5 System Under Test (SUT)

Name:

.....

Version:

.....

SCS reference:

.....

Machine configuration:

.....

Operating system identification:

.....

IUT identification:

.....

PICS (all layers):

.....

.....

Limitations of the SUT:

.....

Environmental conditions:

.....

B.6 Protocol information

B.6.1 Protocol identification

Specification reference: ETS 300 771-1

Protocol version:

PICS reference:

NOTE: The PICS reference should reference a completed PICS which is conformant with the PICS proforma contained in ETS 300 443-2 and ETS 300 771-2.

B.6.2 Configuration to be tested

Table B.1: Configuration to be tested

Item	Configuration: Is the access to be tested ...	Supported? (Y/N)
1.1	of the T _B reference point type?	
1.2	releasing layer 2 after entering the Null link state N0?	

B.6.3 Stimuli for the IUT

Table B.2: Actions required to stimulate the IUT

Item	Action: What actions, if possible, have to be taken to cause the IUT to ...	Supported Y/N	Stimulus (action taken)
2.1	drop all parties towards the root user?		
2.2	drop all parties towards a private B-ISDN? (only, if PIXIT item 1.1 is supported)		
2.3	send a NOTIFY message towards the root user (actions to be performed at one of the leafs)?		

B.6.4 Test management timers

Table B.3: Timer values

Item	Timer: Give a value for the timer that is used ...	Value (in seconds)
3.1	as user side value for T313 (default value 4 seconds).	
3.2	as user side value for T399 (no default value).	
3.3	to wait for the IUT to respond to a stimulus sent by the tester (TAC).	
3.4	to control that the IUT does not respond to a stimulus sent by the tester (TNOAC).	
3.5	to wait for the test operator to perform an implicit send action or to wait for a PTC to react (TWAIT).	
NOTE:	The IUT provider may fill in a value range rather than a fixed value for the test management timers. During test execution the test laboratory will choose specific values for the timers dependant on the means of testing used. These specific values may even be beyond the range given by the IUT provider, if this is necessary for achieving satisfactory test results.	

B.6.5 Parameter values

Table B.4: Parameter values

Item	Parameter values: Give ...	Value
4.1	a coding of an AAL parameters information element, which the IUT is compatible with, for the purpose of accepting outgoing calls.	
4.2	a coding of a Bearer capability information element, which the IUT is compatible with, for the purpose of accepting outgoing calls.	
4.3	a coding of a Low layer compatibility information element, which the IUT is compatible with, for the purpose of accepting outgoing calls.	
4.4	a coding of the Type of number and the Addressing/Numbering plan identification fields of the Called party number information elements to be sent to the IUT.	
4.5	a coding of the number digits of the access related to the PTC1.	
4.6	a coding of the number digits of the access related to the PTC2.	
4.7	a coding of the number digits of a first subscriber at the access related to the MTC.	
4.8	a coding of the number digits of a second subscriber at the access related to the MTC (only, if PIXIT item 1.1 is supported)	
4.9	a coding of an invalid set of number digits for the purpose of rejecting outgoing calls (note)	
4.10	a coding of the forward peak cell rate (CLP = 0) to be sent to the IUT.	
4.11	a coding of the forward peak cell rate (CLP = 0 + 1) to be sent to the IUT.	
4.12	a coding of a Notification indicator information element to be sent to the IUT.	
4.13	an invalid coding of a Notification indicator information element to be sent to the IUT for the purpose of testing the IUT's reaction on the receipt of a non-mandatory information element with content error (note)	
4.14	a value for the preferred VPCI.	
4.15	a value for the preferred VCI.	
4.16	a value for an unrecognized message type.	
4.17	a value for an unrecognized information element identifier.	
NOTE:	This field need only be completed if an invalid coding exists.	

Annex C (normative): Abstract Test Suite (ATS)

This ATS has been produced using the Tree and Tabular Combined Notation (TTCN) according to ISO/IEC 9646-3 [5].

The ATS was developed on a separate TTCN software tool and therefore the TTCN tables are not completely referenced in the contents table. The ATS itself contains a test suite overview part which provides additional information and references.

C.1 The TTCN Graphical form (TTCN.GR)

The TTCN.GR representation of this ATS is contained in a PostScript file (771_6_1.PS contained in archive 7716_ep.LZH) which accompanies the present document.

C.2 The TTCN Machine Processable form (TTCN.MP)

The TTCN.MP representation corresponding to this ATS is contained in an ASCII file (771_6_1.MP contained in archive 7716_ep.LZH) which accompanies the present document.

NOTE: According to ISO/IEC 9646-3 [5], in case of a conflict in interpretation of the operational semantics of TTCN.GR and TTCN.MP, the operational semantics of the TTCN.GR representation takes precedence.

History

Document history	
November 1997	Public Enquiry PE 9811: 1997-11-14 to 1998-03-13