



**E**UROPEAN  
**T**ELECOMMUNICATION  
**S**TANDARD

**DRAFT**  
pr **ETS 300 758-3**

June 1996

---

Source: ETSI TC-RES

Reference: DE/RES-03018-3

ICS: 33.020, 33.040, 33.060.50

**Key words:** DECT, ISDN, PTS, PSTS, FT

**Radio Equipment and Systems (RES);  
Digital Enhanced Cordless Telecommunications (DECT);  
Integrated Services Digital Network (ISDN);  
DECT/ISDN interworking for end system configuration  
Profile Test Specification (PTS);  
Part 3: Profile Specific Test Specification (PSTS)  
for Fixed radio Termination (FT)**

**ETSI**

European Telecommunications Standards Institute

**ETSI Secretariat**

**Postal address:** F-06921 Sophia Antipolis CEDEX - FRANCE

**Office address:** 650 Route des Lucioles - Sophia Antipolis - Valbonne - FRANCE

**X.400:** c=fr, a=atlas, p=etsi, s=secretariat - **Internet:** secretariat@etsi.fr

Tel.: +33 92 94 42 00 - Fax: +33 93 65 47 16

\*

---

**Copyright Notification:** No part may be reproduced except as authorized by written permission. The copyright and the foregoing restriction extend to reproduction in all media.

© European Telecommunications Standards Institute 1996. All rights reserved.



## Contents

Foreword .....	7
1 Scope .....	9
2 Normative references .....	9
3 Definitions and abbreviations .....	12
3.1 Definitions .....	12
3.2 Abbreviations .....	12
4 DECT NWK layer protocol .....	14
4.1 Additional test purposes.....	14
4.2 Abstract test method.....	15
4.3 Relevant test cases.....	15
4.4 Modified test cases .....	17
5 DECT DLC layer protocol.....	18
5.1 Additional test purposes.....	18
5.2 Abstract test method.....	20
5.3 Relevant test cases.....	20
5.4 Additional test cases .....	20
6 DECT MAC layer protocol.....	21
6.1 Additional test purposes.....	21
6.2 Abstract test method.....	22
6.3 Relevant test cases.....	22
6.4 Additional Test Cases.....	24
7 DECT PH layer protocol.....	24
7.1 Additional Test Purposes.....	24
7.2 Abstract test method.....	24
7.3 Relevant test cases.....	24
8 ISDN protocols .....	25
8.1 Applicability of ATS .....	25
8.2 ISDN primary access protocols .....	25
8.2.1 Additional test purposes .....	25
8.2.2 Abstract test method .....	25
8.2.3 Relevant test cases .....	25
8.2.4 Additional selection expression .....	25
8.3 ISDN basic access protocols.....	26
8.3.1 Additional test purposes .....	26
8.3.2 Abstract test method .....	26
8.3.3 Relevant test cases .....	26
8.3.4 Additional selection expression .....	26
9 DECT GAP profile .....	26
9.1 Additional test purposes.....	26
9.2 Abstract test method.....	26
9.3 Relevant test cases.....	26
10 DECT/ISDN IAP profile .....	27
10.1 Profile test suite structure .....	27
10.1.1 Test groups .....	27
10.1.1.1 Protocol groups.....	28
10.1.1.1.1 The IWU procedures .....	28

	10.1.1.1.2	The IWU mappings .....	28
	10.1.1.1.3	The profile specific NWK procedures ..	28
	10.1.1.1.4	The profile specific DLC procedures....	28
	10.1.1.2	Main test groups.....	28
	10.1.1.2.1	Capability (CA) tests.....	29
	10.1.1.2.2	Valid Behaviour (BV) tests .....	29
	10.1.1.2.3	Inopportune Behaviour (BO) tests.....	29
	10.1.1.2.4	Invalid Behaviour (BI) tests .....	29
10.2	Profile test purposes .....		29
10.2.1	TP definition conventions.....		29
10.2.2	TP naming conventions .....		30
10.2.3	Sources of TP definitions.....		30
10.2.4	Test purposes for call establishment procedures.....		31
10.2.5	Test purposes for call information procedures .....		32
10.2.6	Test purposes for call release procedures .....		33
10.2.7	Test purposes for supplementary service specific procedures .....		34
10.2.8	Test purposes for CISS functional protocol procedures.....		38
10.2.9	Test purposes for CRSS functional protocol procedures .....		39
10.2.10	Test purposes for CRSS keypad protocol procedures .....		45
10.2.11	Test purposes for IWU messages mapping .....		46
10.2.12	Test purposes for IWU management of call control protocol .....		48
10.2.13	Test purposes for segmented messages .....		48
10.3	Profile Abstract Test Method (ATM).....		48
10.4	Profile Untestable test purposes .....		49
10.5	Profile ATS Conventions .....		49
10.5.1	Declarations part naming conventions.....		50
10.5.1.1	Type and structured type definitions .....		50
10.5.1.2	Operations definitions .....		50
10.5.1.3	Parameter declarations .....		50
10.5.1.4	Selection expression definitions.....		50
10.5.1.5	Constant declarations .....		50
10.5.1.6	Test suite variable declarations .....		50
10.5.1.7	Test case variable declarations .....		51
10.5.1.8	PCO declarations .....		51
10.5.1.9	Timer declarations .....		51
10.5.1.10	ASP type definitions .....		51
10.5.1.11	PDU type definitions.....		51
10.5.1.12	Alias definitions .....		52
10.5.2	Constraints part naming conventions .....		52
10.5.3	Dynamic part naming conventions.....		52
10.5.3.1	Test Case identifier .....		52
10.5.3.2	Test step identifier.....		53
10.5.3.3	Default identifier .....		53
10.5.3.4	General aspects .....		53
10.5.3.5	ATS abbreviations.....		53
10.5.4	Declaration part implementation conventions.....		53
10.5.5	Constraint part implementation conventions .....		54
10.5.6	Dynamic part implementation conventions .....		54
10.5.7	Documentation implementation conventions.....		55
10.6	Test case and test purpose mapping .....		55
Annex A (normative):	Profile Implementation eXtra Information for Testing (IXIT) proforma for DECT/ISDN IAP profile - Fixed radio Termination (FT).....		56
A.1	Identification summary.....		56
A.2	ATS summary.....		56
A.3	Test laboratory.....		56
A.4	Client identification.....		57
A.5	SUT.....		57

A.6	Profile information .....	58
Annex B (normative):	Profile Conformance Test Report (Profile CTR) proforma for DECT/ISDN IAP profile - Fixed radio Termination (FT).....	60
B.1	Identification summary .....	60
B.1.1	Protocol conformance test report.....	60
B.1.2	IUT identification .....	60
B.1.3	Testing environment .....	61
B.1.4	Limits and reservation.....	61
B.1.5	Comments .....	61
B.2	IUT conformance status.....	61
B.3	Static conformance summary.....	62
B.4	Dynamic conformance summary.....	62
B.5	Static conformance review report.....	62
B.6	Test campaign report .....	63
B.7	Observations .....	64
Annex C (normative):	System Conformance Test Report proforma (SCTR) for DECT/ISDN IAP profile - Fixed radio Termination (FT).....	65
C.1	Identification summary .....	65
C.1.1	System conformance test report.....	65
C.1.2	Test laboratory .....	65
C.1.3	Client identification.....	66
C.1.4	System Under Test (SUT) .....	66
C.1.5	Profile identification.....	66
C.1.6	Nature of conformance testing.....	67
C.1.7	Limits and reservations.....	67
C.1.8	Record of agreement.....	67
C.1.9	Comments .....	68
C.2	System report summary for DECT/ISDN IAP FT .....	68
C.2.1	Profile testing summary for DECT NWK layer protocol .....	68
C.2.2	Profile testing summary for DECT DLC layer protocol .....	69
C.2.3	Profile testing summary for DECT MAC layer protocol.....	70
C.2.4	Profile testing summary for DECT PH layer protocol.....	71
C.2.5	Profile testing summary for ISDN L3, L2, L1 primary access protocol .....	72
C.2.6	Profile testing summary for ISDN L3, L2, L1 basic access protocol.....	73
C.2.7	Profile testing summary for DECT GAP profile.....	74
C.2.8	Profile testing summary for DECT/ISDN IAP profile .....	75
Annex D (normative):	Profile eXtra Requirement List (XRL) proforma for DECT/ISDN IAP profile - Fixed radio Termination (FT).....	76
D.1	ISDN primary access protocols.....	76
D.2	ISDN basic access protocols .....	76
Annex E (normative):	Modifications of the PCTR proforma related to DECT/ISDN IAP profile - Fixed radio Termination (FT).....	77
E.1	Modifications of DECT NWK layer PCTR proforma.....	77
E.2	Modifications of DECT DLC layer PCTR proforma .....	80

E.3	Modifications of DECT MAC layer PCTR proforma.....	82
E.4	Observations.....	84
Annex F (normative):	Abstract Test Suite (ATS) for DECT NWK layer conforming to DECT/ISDN IAP profile - Fixed radio Termination (FT) .....	85
F.1	The machine processable ATS (TTCN.MP).....	85
F.2	The graphical ATS (TTCN.GR) .....	85
Annex G (normative):	Abstract Test Suite (ATS) for DECT DLC layer conforming to DECT/ISDN IAP profile - Fixed radio Termination (FT) .....	86
G.1	The machine processable ATS (TTCN.MP).....	86
G.2	The graphical ATS (TTCN.GR) .....	86
Annex H (normative):	Abstract Test Suite (ATS) for DECT MAC layer conforming to DECT/ISDN IAP profile - Fixed radio Termination (FT) .....	87
H.1	The machine processable ATS (TTCN.MP).....	87
H.2	The graphical ATS (TTCN.GR) .....	87
Annex I (normative):	Abstract Test Suite (ATS) - DECT/ISDN IAP - Fixed radio Termination (FT) ...	88
I.1	The machine processable ATS (TTCN.MP).....	88
I.2	The graphical ATS (TTCN.GR) .....	88
History	.....	89

## Foreword

This draft European Telecommunication Standard (ETS) has been produced by the Radio Equipment and Systems (RES) Technical Committee of the European Telecommunications Standards Institute (ETSI), and is now submitted for the Public Enquiry phase of the ETSI standards approval procedure.

This ETS consists of 3 parts as follows:

Part 1: "PTS - summary".

Part 2: "Profile Specific Test Specification (PSTS) for Portable radio Termination (PT)".

**Part 3: "Profile Specific Test Specification (PSTS) for Fixed radio Termination (FT)".**

<b>Proposed transposition dates</b>	
Date of latest announcement of this ETS (doa):	3 months after ETSI publication
Date of latest publication of new National Standard or endorsement of this ETS (dop/e):	6 months after doa
Date of withdrawal of any conflicting National Standard (dow):	6 months after doa

Blank page



## 1 Scope

This European Telecommunication Standard (ETS) contains the test specification for Digital Enhanced Cordless Telecommunications/Integrated Services Digital Network (DECT/ISDN) Interworking Access Profile (IAP) Fixed Part (FP) applications as specified in ETS 300 434-1 [6] and ETS 300 434-2 [7].

This test specification provides conformance tests for DECT/ISDN terminal equipment conforming to ETS 300 434-1 [6] and ETS 300 434-2 [7]. The main objective is to perform a high probability of interoperability between the DECT/ISDN terminal equipment and an ISDN network. The DECT/ISDN terminal equipment contains Fixed Part and Portable Parts that may be supplied by different manufacturers.

The ISO standard for the methodology of conformance testing ISO/IEC 9646 [22] to [28] is used as the basis for the test methodology, and as the basis for test case specification.

The test cases if listed in this ETS have been derived from the corresponding ATS. Additional DECT/ISDN IAP specific test cases are included where required.

Annex A provides Profile Implementation eXtra Information for Testing (IXIT) proforma part of this specification.

Annex B provides Profile Conformance Test Report (Profile CTR) proforma part of this specification.

Annex C provides System Conformance Test Report proforma (SCTR) part of this specification.

Annex D provides the Profile X requirement list (XRL) proforma part of this specification.

Annex E provides modifications of DECT layer PCTR proforma of this specification.

Annex F provides the Tree and Tabular Combined Notation (TTCN) part for DECT NWK layer conforming to the requirements of this specification.

Annex G provides the Tree and Tabular Combined Notation (TTCN) part for DECT DLC layer conforming to the requirements of this specification.

Annex H provides the Tree and Tabular Combined Notation (TTCN) part for DECT MAC layer conforming to the requirements of this specification.

Annex I provides the Tree and Tabular Combined Notation (TTCN) part for DECT/ISDN IWU - IAP profile.

## 2 Normative references

- [1] ETS 300 175-2: "Radio Equipment and Systems (RES); Digital European Cordless Telecommunications (DECT); Common Interface (CI); Part 2: Physical Layer".
- [2] ETS 300 175-3: "Radio Equipment and Systems (RES); Digital European Cordless Telecommunications (DECT); Common Interface (CI); Part 3: Medium Access Control (MAC) layer".
- [3] ETS 300 175-4: "Radio Equipment and Systems (RES); Digital European Cordless Telecommunications (DECT); Common Interface (CI); Part 4: Data Link Control (DLC) layer".
- [4] ETS 300 175-5: "Radio Equipment and Systems (RES); Digital European Cordless Telecommunications (DECT); Common Interface (CI); Part 5: Network (NWK) layer".
- [5] ETS 300 444 (1995): "Radio Equipment and Systems (RES); Digital European Cordless Telecommunications (DECT); Generic Access Profile (GAP)".

- [6] ETS 300 434-1: "Radio Equipment and Systems (RES); Digital Enhanced Cordless Telecommunications (DECT) and Integrated Services Digital Network (ISDN) interworking for end system configuration; Part 1: Interworking specification".
- [7] ETS 300 434-2: "Radio Equipment and Systems (RES); Digital Enhanced Cordless Telecommunications (DECT) and Integrated Services Digital Network (ISDN) interworking for end system configuration; Part 2: Access profile".
- [8] prETS 300 176: "Radio Equipment and Systems (RES); Digital European Cordless Telecommunications (DECT); Approval test specification".
- [9] prETS 300 476-4: "Radio Equipment and Systems (RES); Digital Enhanced Cordless Telecommunications (DECT); Common Interface (CI); Protocol Implementation Conformance Statement (PICS) proforma; Part 4: Network (NWK) layer - Fixed radio Termination (FT)".
- [10] prETS 300 476-5: "Radio Equipment and Systems (RES); Digital Enhanced Cordless Telecommunications (DECT); Common Interface (CI); Protocol Implementation Conformance Statement (PICS) proforma; Part 5: Data Link Control (DLC) layer - Fixed radio Termination (FT)".
- [11] prETS 300 476-6: "Radio Equipment and Systems (RES); Digital Enhanced Cordless Telecommunications (DECT); Common Interface (CI); Protocol Implementation Conformance Statement (PICS) proforma; Part 6: Medium Access Control (MAC) layer - Fixed radio Termination (FT)".
- [12] prETS 300 476-7: "Radio Equipment and Systems (RES); Digital Enhanced Cordless Telecommunications (DECT); Common Interface (CI); Protocol Implementation Conformance Statement (PICS) proforma; Part 7: Physical layer".
- [13] prETS 300 474-2: "Radio Equipment and Systems (RES); Digital Enhanced Cordless Telecommunications (DECT); Generic Access Profile (GAP); Profile requirement list and profile specific Implementation Conformance Statement (ICS) proforma; Part 2: Fixed radio Termination (FT)"
- [14] ETS 300 705-2: "Radio Equipment and Systems (RES); Digital Enhanced Cordless Telecommunications/Integrated Services Digital Network (DECT/ISDN) interworking for end system configuration; Profile Implementation Conformance Statement (ICS); Part 2: Fixed radio Termination (FT)".
- [15] prETS 300 497-1: "Radio Equipment and Systems (RES); Digital Enhanced Cordless Telecommunications (DECT); Common Interface (CI) Test Case Library (TCL); Part 1: Test Suite Structure (TSS) and Test Purposes (TP) for Medium Access Control (MAC) layer".
- [16] prETS 300 497-3: "Radio Equipment and Systems (RES); Digital Enhanced Cordless Telecommunications (DECT); Common Interface (CI) Test Case Library (TCL); Part 3: Abstract Test Suite (ATS) for Medium Access Control (MAC) layer - Fixed radio Termination (FT)".
- [17] prETS 300 497-4: "Radio Equipment and Systems (RES); Digital Enhanced Cordless Telecommunications (DECT); Common Interface (CI) Test Case Library (TCL); Part 4: Test Suite Structure (TSS) and Test Purposes (TP) - Data Link Control (DLC) layer".
- [18] prETS 300 497-5: "Radio Equipment and Systems (RES); Digital Enhanced Cordless Telecommunications (DECT); Common Interface (CI) Test Case Library (TCL); Part 5: Abstract Test Suite (ATS) - Data Link Control (DLC) layer".

- [19] prETS 300 497-8: "Radio Equipment and Systems (RES); Digital Enhanced Cordless Telecommunications (DECT); Common Interface (CI) Test Case Library (TCL); Part 8: Test Suite Structure (TSS) and Test Purposes (TP) - Network (NWK) layer - Fixed radio Termination (FT)".
- [20] prETS 300 497-9: "Radio Equipment and Systems (RES); Digital Enhanced Cordless Telecommunications (DECT); Common Interface (CI) Test Case Library (TCL); Part 9: Abstract Test Suite (ATS) for Network (NWK) layer - Fixed radio Termination (FT)".
- [21] prETS 300 494-3: "Radio Equipment and Systems (RES); Digital Enhanced Cordless Telecommunications (DECT); Generic Access Profile (GAP); Profile Test Specification (PTS); Part 3: Profile Specific Test Specification (PSTS) - Fixed radio Termination (FT)".
- [22] ISO/IEC 9646-1 (1991): "Information technology - Open Systems Interconnection - Conformance testing methodology and framework - Part 1: General concepts". (See also CCITT Recommendation X.290 (1991)).
- [23] ISO/IEC 9646-2 (1991): "Information technology - Open Systems Interconnection - Conformance testing methodology and framework - Part 2: Abstract test suite specification". (See also CCITT Recommendation X.291 (1991)).
- [24] ISO/IEC 9646-3 (1991): "Information technology - Open Systems Interconnection - Conformance testing methodology and framework - Part 3: The tree and tabular combined notation". (See also CCITT Recommendation X.292 (1992)).
- [25] ISO/IEC 9646-4 (1991): "Information technology - Open Systems Interconnection - Conformance testing methodology and framework - Part 4: Test realisation". (See also CCITT Recommendation X.292 (1992)).
- [26] ISO/IEC 9646-5 (1991): "Information technology - Open Systems Interconnection - Conformance testing methodology and framework - Part 5: Requirements on test laboratories and clients for the conformance assessment process". (See also CCITT Recommendation X.292 (1992)).
- [27] ISO/IEC 9646-6 (1991): "Information technology - Open Systems Interconnection - Conformance testing methodology and framework - Part 6: Protocol profile test specification".
- [28] ISO/IEC 9646-7 (1991): "Information technology - Open Systems Interconnection - Conformance testing methodology and framework - Part 7: Implementation conformance statement".
- [29] ETS 300 403-1: "Integrated Services Digital Network (ISDN); Digital Subscriber Signalling System No. one (DSS1) protocol; Signalling network layer for circuit-mode basic call control; Part 1: Protocol specification [ITU-T Recommendation Q.931 (1993), modified]".
- [30] ETS 300 403-3: "Integrated Services Digital Network (ISDN); Digital Subscriber Signalling System No. one (DSS1) protocol; Signalling network layer for circuit-mode basic call control; Part 3: Protocol Implementation Conformance Statement (PICS) proforma specification".
- [31] ETS 300 402-2: "Integrated Services Digital Network (ISDN); Digital Subscriber Signalling System No. one (DSS1) protocol; Data link layer; Part 2: General protocol specification [ITU-T Recommendation Q.921 (1993), modified]".

- [32] prETS 300 402-4: "Integrated Services Digital Network (ISDN); Digital Subscriber Signalling System No. one (DSS1) protocol; Data link layer; Part 4: Protocol Implementation Conformance Statement (PICS) proforma specification for the general protocol".
- [33] ETS 300 011 (1992): "Integrated Services Digital Network (ISDN); Primary rate user-network interface; Layer 1 specification and test principles".
- [34] ETS 300 011/A2: "Amendment 2 to ETS 300 011 (1992), adding a SCS, a PICS and a PIXIT for interface points I<sub>a</sub> and I<sub>b</sub>".
- [35] ETS 300 012 (1992): "Integrated Services Digital Network (ISDN); Basic user-network interface; Layer 1 specification and test principles".
- [36] ETS 300 012/A2: "Amendment 2 to ETS 300 012 (1992), adding a SCS, a PICS and a PIXIT for interface points I<sub>a</sub> and I<sub>b</sub>".
- [37] TBR 3: "Integrated Services Digital Network (ISDN); Attachment requirements for terminal equipment to connect to an ISDN using ISDN basic access".
- [38] TBR 4: "Integrated Services Digital Network (ISDN); Attachment requirements for terminal equipment to connect to an ISDN using ISDN primary rate access".
- [39] prTBR 22: "Radio Equipment and Systems (RES); Attachment requirements for terminal equipment for Digital Enhanced Cordless Telecommunications (DECT) Generic Access Profile (GAP) applications".

### 3 Definitions and abbreviations

#### 3.1 Definitions

For the purposes of this ETS, the following terms and definitions apply:

- a) The terms defined in ISO/IEC 9646-7 [28]; and
- b) The definitions in ETS 300 434-1 [6] and ETS 300 434-2 [7].

#### 3.2 Abbreviations

For the purposes of this ETS, the abbreviations defined in ISO/IEC 9646-1 [22], ISO/IEC 9646-6 [27], ISO/IEC 9646-7 [28], the abbreviations defined in ETS 300 434-1 [6] and ETS 300 434-2 [7] apply. In particular, the following abbreviations apply:

ASP	Abstract Service Primitive
ATM	Abstract Test Method
BI	Invalid Behaviour
BO	Inopportune Behaviour
BV	Valid Behaviour
CA	Capability tests
CC	Call Control entity
CI	Common Interface
DECT	Digital Enhanced Cordless Telecommunications
DLC	Data Link Control layer
FT	Fixed radio Termination
GAP	Generic Access Profile
ICS	Implementation Conformance Statement
ISDN	Integrated Services Digital Network
ISO	International Organisation for Standardisation
IUT	Implementation Under Test
IXIT	Implementation eXtra Information for Testing
IWP	Interworking Profile
LCE	Link Control Entity
LT	Lower Tester

MAC	Medium Access Control layer
MM	Mobility Management entity
NWK	Network layer
PDU	Protocol Data Unit
PH	Physical layer
PICS	Protocol Implementation Conformance Statement
PIXIT	Protocol Implementation eXtra Information for Testing
PSTS	Profile Specific Test Specification
PT	Portable radio Termination
PTS	Profile Test Specification
SDU	Service Data Unit
SCS	System Conformance Statement
SUT	System Under Test
TP	Test Purpose
TSS	Test Suite Structure
XRL	IXIT Requirements list

## 4 DECT NWK layer protocol

### 4.1 Additional test purposes

Figure 1 shows the Network Test Suite Structure (TSS) defined in ETS 300 497-8 [19] for the conformance testing.

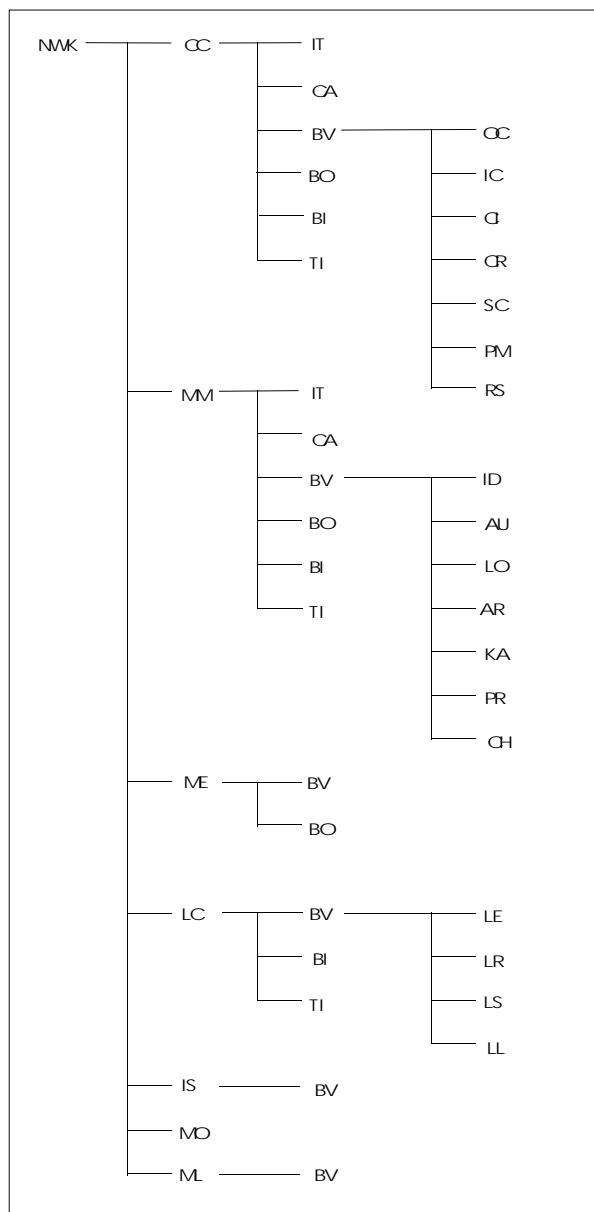

**Figure 1: NWK TSS**

All test purposes for CC entity of the NWK layer as specified in ETS 300 497-8 [19] apply with no required addition.

All test purposes for LCE entity of the NWK layer as specified in ETS 300 497-8 [19] apply with no required addition.

All test purposes for CISS entity of the NWK layer as specified in ETS 300 497-8 [19] apply with no required addition.

#### 4.2 Abstract test method

As stated in ETS 300 497-9 [20], the ATM used for the DECT NWK layer is the remote embedded test method.

The DECT/ISDN IAP implies no modification for the definition and the use of the ATM.

#### 4.3 Relevant test cases

The test cases defined for the test group "FT/CC/BV/OC" in ETS 300 497-9 [20] relevant for the profile according to their own selection rules are:

- TC\_FT\_CC\_BV\_OC\_01;
- TC\_FT\_CC\_BV\_OC\_02;
- TC\_FT\_CC\_BV\_OC\_03;
- TC\_FT\_CC\_BV\_OC\_04;
- TC\_FT\_CC\_BV\_OC\_05.

The test cases defined for the test group "FT/CC/BV/IC" in ETS 300 497-9 [20] relevant for the profile according to their own selection rules are:

- TC\_FT\_CC\_BV\_IC\_01;
- TC\_FT\_CC\_BV\_IC\_02.

The test cases defined for the test group "FT/CC/BV/CI" in ETS 300 497-9 [20] relevant for the profile according to their own selection rules are:

- TC\_FT\_CC\_BV\_CI\_01;
- TC\_FT\_CC\_BV\_CI\_02;
- TC\_FT\_CC\_BV\_CI\_03;
- TC\_FT\_CC\_BV\_CI\_04;
- TC\_FT\_CC\_BV\_CI\_05;
- TC\_FT\_CC\_BV\_CI\_06;
- TC\_FT\_CC\_BV\_CI\_07;
- TC\_FT\_CC\_BV\_CI\_08;
- TC\_FT\_CC\_BV\_CI\_09;
- TC\_FT\_CC\_BV\_CI\_10.

The test cases defined for the test group "FT/CC/BV/CR" in ETS 300 497-9 [20] relevant for the profile according to their own selection rules are:

- TC\_FT\_CC\_BV\_CR\_01;
- TC\_FT\_CC\_BV\_CR\_02;
- TC\_FT\_CC\_BV\_CR\_03;
- TC\_FT\_CC\_BV\_CR\_04;
- TC\_FT\_CC\_BV\_CR\_05;
- TC\_FT\_CC\_BV\_CR\_06;
- TC\_FT\_CC\_BV\_CR\_07;
- TC\_FT\_CC\_BV\_CR\_08;
- TC\_FT\_CC\_BV\_CR\_09;
- TC\_FT\_CC\_BV\_CR\_10;
- TC\_FT\_CC\_BV\_CR\_11;
- TC\_FT\_CC\_BV\_CR\_12.

The test cases defined for the test group "FT/CC/BV/RS" in ETS 300 497-9 [20] relevant for the profile according to their own selection rules are:

- TC\_FT\_CC\_BV\_RS\_07.

The test cases defined for the test group "FT/CC/BV/BO" in ETS 300 497-9 [20] relevant for the profile according to their own selection rules are:

- TC\_FT\_CC\_BV\_BO\_01;
- TC\_FT\_CC\_BV\_BO\_02.

The test cases defined for the test group "FT/CC/BI" in ETS 300 497-9 [20] relevant for the profile according to their own selection rules are:

- TC\_FT\_CC\_BI\_01;
- TC\_FT\_CC\_BI\_02;
- TC\_FT\_CC\_BI\_03;
- TC\_FT\_CC\_BI\_04.

The test cases defined for the test group "FT/CC/TI" in ETS 300 497-9 [20] relevant for the profile according to their own selection rules are:

- TC\_FT\_CC\_TI\_01;
- TC\_FT\_CC\_TI\_02;
- TC\_FT\_CC\_TI\_03;
- TC\_FT\_CC\_TI\_04.

The test cases defined for the test group "FT/LC/BV/LE" in ETS 300 497-9 [20] relevant for the profile according to their own selection rules are:

- TC\_FT\_LC\_BV\_LE\_01;
- TC\_FT\_LC\_BV\_LE\_02;
- TC\_FT\_LC\_BV\_LE\_03.

The test cases defined for the test group "FT/LC/BV/LR" in ETS 300 497-9 [20] relevant for the profile according to their own selection rules are:

- TC\_FT\_LC\_BV\_LR\_01;
- TC\_FT\_LC\_BV\_LR\_02;
- TC\_FT\_LC\_BV\_LR\_03;
- TC\_FT\_LC\_BV\_LR\_04.

The test cases defined for the test group "FT/LC/BI" in ETS 300 497-9 [20] relevant for the profile according to their own selection rules are:

- TC\_FT\_LC\_BI\_01;
- TC\_FT\_LC\_BI\_03;
- TC\_FT\_LC\_BI\_04;
- TC\_FT\_LC\_BI\_05;
- TC\_FT\_LC\_BI\_06;
- TC\_FT\_LC\_BI\_07.

The test cases defined for the test group "FT/LC/TI" in ETS 300 497-9 [20] relevant for the profile according to their own selection rules are:

- TC\_FT\_LC\_TI\_02;
- TC\_FT\_LC\_TI\_03.

The test cases defined for the test group "FT/IS/BV" in ETS 300 497-9 [20] relevant for the profile according to their own selection rules are:

- TC\_FT\_IS\_BV\_01;
- TC\_FT\_IS\_BV\_02;
- TC\_FT\_IS\_BV\_03.



#### 4.4 Modified test cases

Test cases, in which the following call control messages can be received and sent, are considered as modified test cases due to the new format of these messages:

- CC-SETUP;
- CC-INFO;
- CC-ALERTING;
- CC-CONNECT;
- CC-RELEASE;
- CC-RELEASE-COM.

The new format of these messages implies a set of modified TTCN constraint.

Test cases, in which the following call control messages can be sent, are considered as modified test cases due to the new format of these messages:

- CC-SETUP-ACK;
- CC-CALL-PROC;
- CC-CONNECT-ACK.

The new format of these messages implies a set of modified TTCN constraint.

Test cases, in which the following CISS messages can be received and sent, are considered as modified test cases due to the new format of these messages:

- FACILITY-ciss;
- CISS-REGISTER;
- CISS-RELEASE-COM.

The new format of these messages implies a set of modified TTCN constraint.

Test cases, in which the following CISS messages can be sent, are considered as modified test cases due to the new format of these messages:

- HOLD-REJECT;
- RETRIEVE-REJECT.

The new format of these messages implies a set of modified TTCN constraint.

Test cases, in which some messages use the following information elements, are considered as modified test cases due to the new value range of some fields:

- Call attributes;
- IWU-to-IWU;
- Progress indicator.

The new value range of the fields of these information elements implies a set of modified TTCN constraint.

Test cases, in which the CC\_02 timer is used, are considered as modified test cases due to the new value of this timer.

The value of the CC\_02 timer (changed from 30s to 36s) shall be updated by modifying the associated test suite parameter.

## 5 DECT DLC layer protocol

### 5.1 Additional test purposes

Figure 2 shows the Data Link Control Test Suite Structure (TSS) defined in ETS 300 497-4 [17] for the conformance testing.

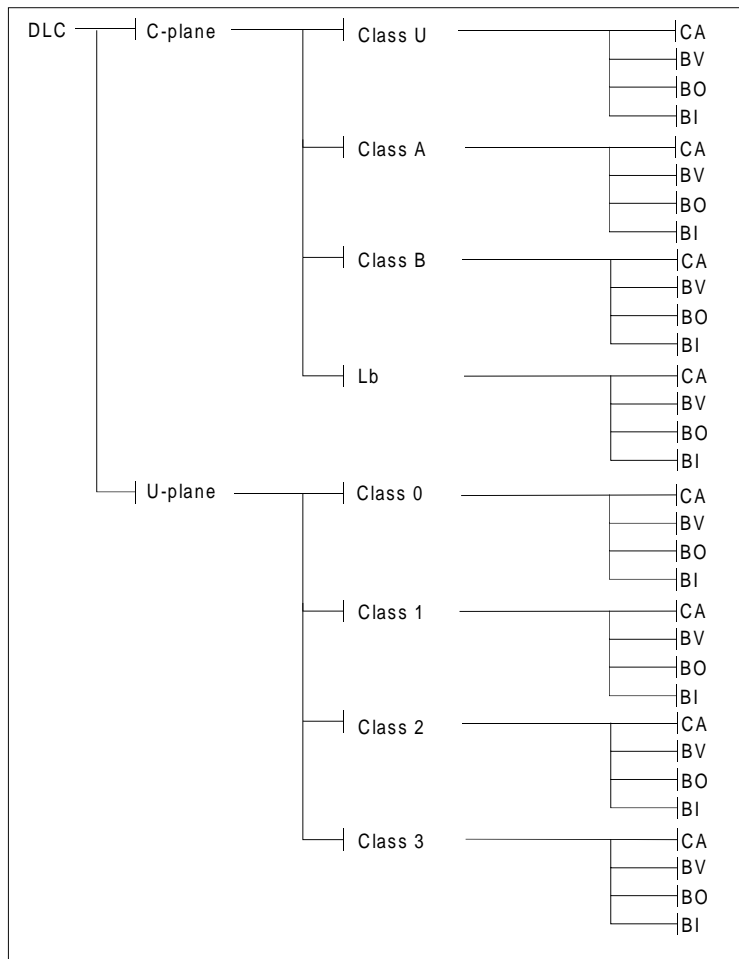

**Figure 2: DLC TSS**

Additional test purposes for LU7 are added in the functional module "Class 0" and in the corresponding standard main test group CA, BV, BO and BI.

According to the TP naming convention and the existing TP defined in ETS 300 497-4 [17], the identifier to use for the first additional test purpose is "DLC/U-Plane/Class0/TP0V-000".

<b>DLC/U-Plane/Class0/TP0V-000</b>	<p>ETS 300 434-1 [6], subclause B.4.3.2.1 ETS 300 476-2 [10] Protocol ICS table A.28 item 1</p> <p>Only for an IUT, that transmits a stream of data frames after the establishment of the LU7 service.</p> <p>Initial condition: The LU7 service is established. The IUT received a frame with incorrect checksum, and the IUT's <math>V(O) = 0</math>.</p> <p>Check that the IUT uses the first time transmission procedure with a 64 kbit/s frame format to transmit the next frames.</p>
<b>DLC/U-Plane/Class0/TP0V-001</b>	<p>ETS 300 434-1 [6], subclause B.4.3.2.1 ETS 300 476-2 [10] Protocol ICS table A.28 item 1</p> <p>Only for an IUT, that transmits a stream of data frames after the establishment of the LU7 service.</p> <p>Initial condition: The LU7 service is established. The IUT received a frame with incorrect checksum, and the IUT's <math>V(O) = (\text{Max. VO value} - 8)</math>.</p> <p>Check that the IUT uses the 72 kbit/s frame format to transmit the next frames.</p>
<b>DLC/U-Plane/Class0/TP0V-002</b>	<p>ETS 300 434-1 [6], subclause B.4.3.2.2 ETS 300 476-2 [10] Protocol ICS table A.28 item 2</p> <p>Only for an IUT, that transmits a stream of data frames after the establishment of the LU7 service.</p> <p>Initial condition: The LU7 service is established. The IUT received a re-transmit request, and the IUT's <math>V(O) &lt; (\text{Max. VO value})</math>.</p> <p>Check that the IUT re-transmits the requested frame with the same frame speed format as the initial sending of this frame.</p>
<b>DLC/U-Plane/Class0/TP0V-003</b>	<p>ETS 300 434-1 [6], subclause B.4.3.2.4 ETS 300 476-2 [10] Protocol ICS table A.28 item 4</p> <p>Only for an IUT, that transmits a stream of data frames after the establishment of the LU7 service.</p> <p>Initial condition: The LU7 service is established. The IUT received 64 kbit/s frames, and the IUT's <math>V(O) = 0</math>.</p> <p>Check that the IUT acknowledges the received frames by transmitting a frame with <math>N(R)</math> set to the correct value.</p>
<b>DLC/U-Plane/Class0/TP0V-004</b>	<p>ETS 300 434-1 [6], subclause B.4.3.2.5 ETS 300 476-2 [10] Protocol ICS table A.28 item 5</p> <p>Only for an IUT, that transmits a stream of data frames after the establishment of the LU7 service.</p> <p>Initial condition: The LU7 service is established. The IUT received 64 kbit/s frames, and the IUT's <math>V(O) = 0</math>.</p> <p>Check that the IUT treats the <math>N(R)</math> value contained in a received frame as an acknowledgement for all frames it has transmitted with an <math>N(S)</math> up to this value.</p>

## 5.2 Abstract test method

As stated in ETS 300 497-5 [18], the ATM used for the DECT DLC layer is the remote embedded test method. The fragmentation and recombination of the  $C_F$  and  $C_S$  channels (subset of Lc entity) are considered as a part of the lower layer under the PCO.

The DECT/ISDN IAP implies no modification for the definition and the use of the ATM.

## 5.3 Relevant test cases

All test cases defined for the test group "DLC/C-Plane/ClassA" in ETS 300 497-5 [18] are relevant for the profile according to their own selection rules.

All test cases defined for the test group "DLC/C-Plane/Lb" in ETS 300 497-5 [18] are relevant for the profile according to their own selection rules.

All test cases defined for the test group "DLC/U-Plane/Class0" in ETS 300 497-5 [18] are relevant for the profile according to their own selection rules.

## 5.4 Additional test cases

For covering the new test purposes, the derived test cases are:

- TC-0-BV-000;
- TC-0-BV-001;
- TC-0-BV-002;
- TC-0-BV-003;
- TC-0-BV-004.

## 6 DECT MAC layer protocol

### 6.1 Additional test purposes

Figure 3 shows the MAC Test Suite Structure (TSS) defined in ETS 300 497-1 [15] for the conformance testing.

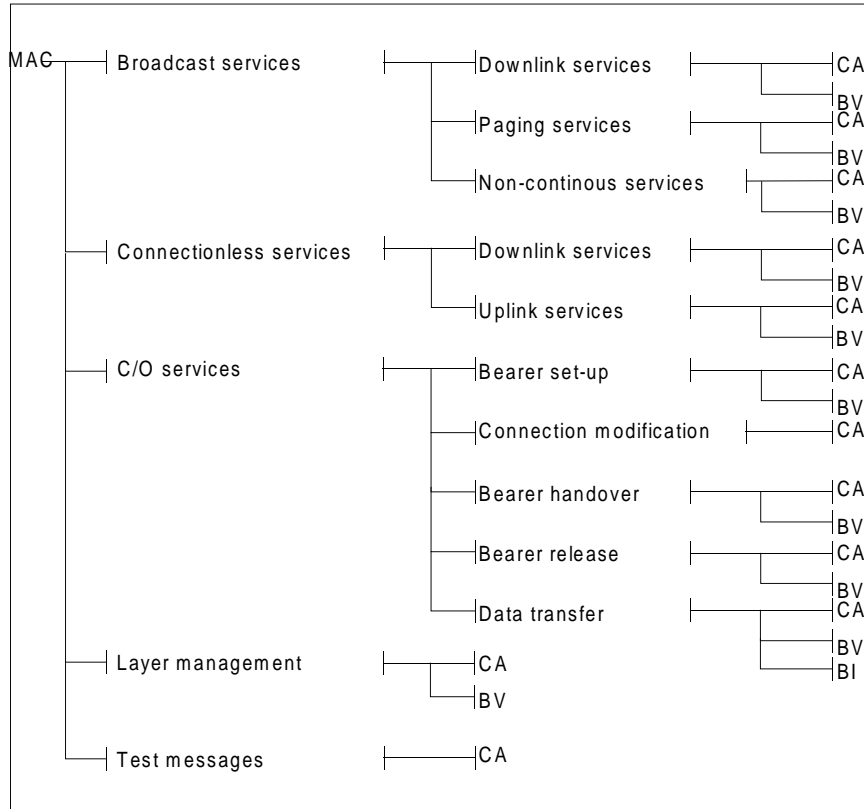

**Figure 3: TSS for DECT MAC layer (layer 2a of DECT protocol stack)**

The study of the test purposes defined in ETS 300 497-1 [15] express that some new test purposes have to be added.

For 64 kbit/s unrestricted digital information:

additional test purposes shall be defined in "BS/CA" and "BS/BV" test groups for testing setup of advanced symmetric connections (PT initiated - B field single bearer setup procedure);

additional test purposes shall be added in "BR/CA" test group for testing release of advanced symmetric connections (Unacknowledged bearer release procedure).

Additional BS/CA test purposes:

<b>TP/BS/CA-02</b>	<p>ETS 300 434-2 [7], subclause 7.2.1.1                  ETS 300 705-2 [14] Profile ICS RL table B.72 item 3</p> <p>For FT only.                  Initial state: Active_idle.</p> <p>Check that the IUT manages rightly the PT initiated B field single bearer setup procedure.</p>
--------------------	---

Additional BS/BV test purposes:

<b>TP/BS/BV-01</b>	<p>ETS 300 434-2 [7], subclause 7.2.1.1 ETS 300 705-2 [14] Profile ICS RL table B.72 item 3</p> <p>Initial state: Active_traffic or Active_traffic_and_idle</p> <p>Check that the IUT releases a duplex bearer in case the timer T201 expires during B-field advanced bearer setup procedure.</p>
--------------------	---

Additional BR/CA test purposes:

<b>TP/BR/CA-01</b>	<p>ETS 300 434-2 [7], subclause 7.2.1.1 ETS 300 705-2 [14] Profile ICS RL table B.75 item 1</p> <p>Initial state: Active_traffic or Active_traffic_and_idle</p> <p>Check that the IUT manages rightly an unacknowledged release procedure of an advanced duplex bearer when receiving a B-field release message.</p>
--------------------	--

For Paging:

Additional test purposes shall be added in "PG/CA" test group for testing full page format of paging messages.

Additional PG/CA test purposes:

<b>TP/PG/CA-02</b>	<p>ETS 300 434-2 [7], subclause 7.3.2.3 ETS 300 705-2 [14] Profile ICS RL table B.83 item 1</p> <p>For FT only. Initial state: Active_idle.</p> <p>Check that the FT can transmit a correct full page message.</p>
--------------------	--

## 6.2 Abstract test method

As stated in ETS 300 497-3 [16], the ATM used for the DECT MAC layer is a specific test method using specific MAC layer implementation on the tester.

The DECT/ISDN IAP implies no modification for the definition and the use of the ATM.

## 6.3 Relevant test cases

The test cases defined for the test group "DB/CA" in ETS 300 497-3 [16] relevant for the profile according to their own selection rules are:

- TC\_FT\_DB\_CA\_00;
- TC\_FT\_DB\_CA\_01;
- TC\_FT\_DB\_CA\_02;
- TC\_FT\_DB\_CA\_03;
- TC\_FT\_DB\_CA\_04;
- TC\_FT\_DB\_CA\_05;
- TC\_FT\_DB\_CA\_06;
- TC\_FT\_DB\_CA\_07.

The test cases defined for the test group "DB/BV" in ETS 300 497-3 [16] relevant for the profile according to their own selection rules are:

- TC\_FT\_DB\_BV\_03.

The test cases defined for the test group "PG/CA" in ETS 300 497-3 [16] relevant for the profile according to their own selection rules are:

- TC\_FT\_PG\_CA\_00;
- TC\_FT\_PG\_CA\_01.

The test cases defined for the test group "PG/BV" in ETS 300 497-3 [16] relevant for the profile according to their own selection rules are:

- TC\_FT\_PG\_BV\_01.

The test cases defined for the test group "BS/CA" in ETS 300 497-3 [16] relevant for the profile according to their own selection rules are:

- TC\_FT\_BS\_CA\_00.

The test cases defined for the test group "BS/BV" in ETS 300 497-3 [16] relevant for the profile according to their own selection rules are:

- TC\_FT\_BS\_BV\_00.

The test cases defined for the test group "BH/BV" in ETS 300 497-3 [16] relevant for the profile according to their own selection rules are:

- TC\_FT\_BH\_BV\_00;
- TC\_FT\_BH\_BV\_01.

The test cases defined for the test group "BH/CA" in ETS 300 497-3 [16] relevant for the profile according to their own selection rules are:

- TC\_FT\_BH\_CA\_00;
- TC\_FT\_BH\_CA\_01.

The test cases defined for the test group "BR/CA" in ETS 300 497-3 [16] relevant for the profile according to their own selection rules are:

- TC\_FT\_BR\_CA\_00.

The test cases defined for the test group "DT/CA" in ETS 300 497-3 [16] relevant for the profile according to their own selection rules are:

- TC\_FT\_DT\_CA\_00;
- TC\_FT\_DT\_CA\_01;
- TC\_FT\_DT\_CA\_02;
- TC\_FT\_DT\_CA\_03;
- TC\_FT\_DT\_CA\_04.

The test cases defined for the test group "DT/BV" in ETS 300 497-3 [16] relevant for the profile according to their own selection rules are:

- TC\_FT\_DT\_BV\_00;
- TC\_FT\_DT\_BV\_01.

The test cases defined for the test group "DT/BI" in ETS 300 497-3 [16] relevant for the profile according to their own selection rules are:

- TC\_FT\_DT\_BI\_00;
- TC\_FT\_DT\_BI\_01.

The test cases defined for the test group "LM/CA" in ETS 300 497-3 [16] relevant for the profile according to their own selection rules are:

- TC\_FT\_LM\_CA\_05.

#### **6.4 Additional Test Cases**

For covering the new defined test purposes of the test group "BS/CA", the additional test cases are:

- TC\_FT\_BS\_CA\_02

For covering the new defined test purposes of the test group "BS/BV", the additional test cases are:

- TC\_FT\_BS\_BV\_01

For covering the new defined test purposes of the test group "BR/CA", the additional test cases are:

- TC\_FT\_BR\_CA\_01

For covering the new defined test purposes of the test group "PG/CA", the additional test cases are:

- TC\_FT\_PG\_CA\_02

## **7 DECT PH layer protocol**

### **7.1 Additional Test Purposes**

All requirements for PH layer as specified in TBR 22 [39] apply with no required addition.

### **7.2 Abstract test method**

The ATM and the applicability of the ATS for PH layer as defined in TBR 22 [39] apply.

### **7.3 Relevant test cases**

All test cases for PH layer as specified in TBR 22 [39] apply with no required addition.



## 8 ISDN protocols

### 8.1 Applicability of ATS

The user side ATS for ISDN protocols are designed for ISDN terminal equipment. For DECT/ISDN IAP profile, FT part and PT part joined is the ISDN terminal equipment. Figure 4 below, indicate how to test FT for ISDN protocols.

The tested FT has first to be conformant to ISDN protocols before all other parts of IAP profile. If not, testing for all other parts of IAP profile is not relevant.

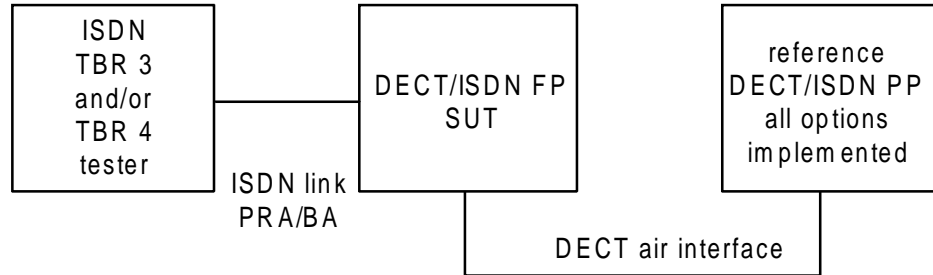

PRA: Primary rate access  
 BA: Basic Access

**Figure 4: ISDN protocols testing at FT**

### 8.2 ISDN primary access protocols

#### 8.2.1 Additional test purposes

All requirements for all layer of the ISDN primary access protocols as specified in TBR 4 [38] apply with no required addition.

#### 8.2.2 Abstract test method

The ATM of the ATS for all layer of the ISDN primary access protocols as defined in TBR 4 [38] apply.

#### 8.2.3 Relevant test cases

All test cases for all layer of the ISDN primary access protocols as specified in TBR 4 [38] apply with no required addition.

#### 8.2.4 Additional selection expression

The selection expression, described in table 1, shall be use to select test cases in the ATS of the ISDN primary access protocol (TBR 4 [38]).

**Table 1: ISDN primary access protocol selection expression**

Expression Name	Selection rule
PISDN_SelectAll	IF NOT PISDN_implemented THEN All test cases shall be de-selected ELSE All test cases shall be selected according to the other selection rules.

**8.3 ISDN basic access protocols****8.3.1 Additional test purposes**

All requirements for all layer of the ISDN basic access protocols as specified in TBR 3 [37] apply with no required addition.

**8.3.2 Abstract test method**

The ATM for all layer of the ISDN basic access protocols as defined in TBR 3 [37] apply.

**8.3.3 Relevant test cases**

All test cases for all layer of the ISDN basic access protocols as specified in TBR 3 [37] apply with no required addition.

**8.3.4 Additional selection expression**

The selection expression, described in table 2, shall be use to select test cases in the ATS of the ISDN basic access protocol (TBR 3 [37]).

**Table 2: ISDN basic access protocol selection expression**

<b>Expression Name</b>	<b>Selection rule</b>
BISDN_SelectAll	IF NOT BISDN_implemented THEN All test cases shall be de-selected ELSE All test cases shall be selected according to the other selection rules.

**9 DECT GAP profile****9.1 Additional test purposes**

All requirements for all layer of the GAP profile as specified in TBR 22 [39] apply with no required addition.

**9.2 Abstract test method**

The ATM and the applicability of the ATS for all layer of the GAP profile as defined in TBR 22 [39] apply.

**9.3 Relevant test cases**

All test cases for all layer of the GAP profile as specified in TBR 22 [39] apply with no required addition.

## 10 DECT/ISDN IAP profile

### 10.1 Profile test suite structure

The test suite is structured as a tree with a first level defined as IAP representing the profile IWU group "DECT/ISDN IWU IAP".

The figure 5 below shows the DECT/ISDN IWU Test Suite Structure (TSS) defined for the conformance testing.

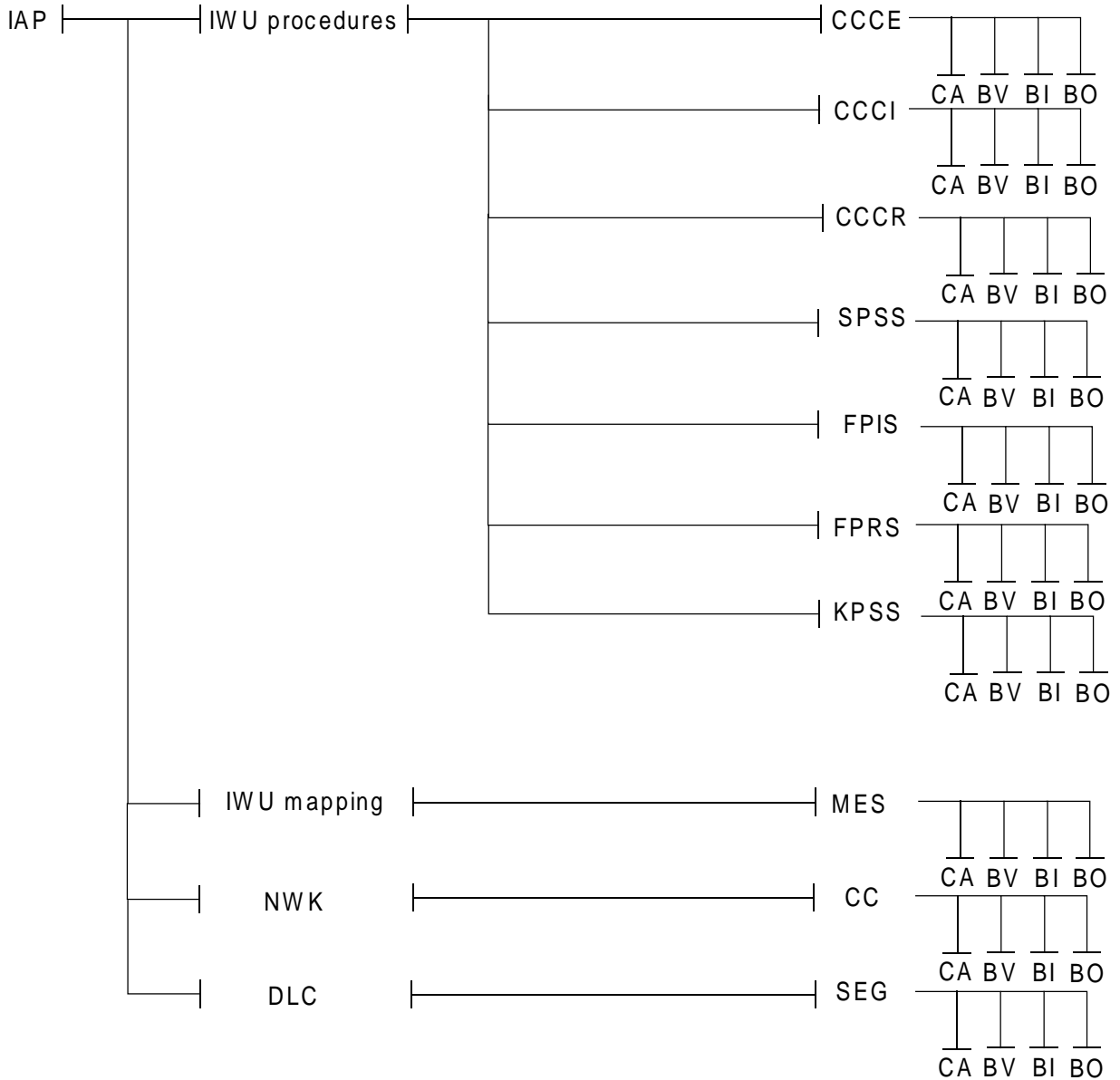

Figure 5: TSS for DECT IAP profile - Fixed Termination (FT)

#### 10.1.1 Test groups

The test groups are organised in three levels. The first level creates four protocol groups representing the main functions of the profile. The second level separates each protocol group in functional modules. The last level contains the standard ISO subgroups CA, BV, BO and BI.

### **10.1.1.1 Protocol groups**

The protocol groups are:

- The IWU procedures;
- The IWU mappings;
- The profile specific NWK procedures;
- The profile specific DLC procedures.

#### **10.1.1.1.1 The IWU procedures**

This protocol group is divided in seven functional modules.

The first functional module (CCCE) is the test group designed for the call establishment procedures of the call control protocol.

The second functional module (CCCI) is the test group designed for the call information procedures of the call control protocol.

The third functional module (CCCR) is the test group designed for the call release procedures of the call control protocol.

The fourth functional module (SPSS) is the test group designed for the specific procedures for supplementary services.

The fifth functional module (FPIS) is the test group designed for the procedures of the CISS functional protocol.

The sixth functional module (FPRS) is the test group designed for the procedures of the CRSS functional protocol.

The seventh functional module (KPSS) is the test group designed for the procedures of CRSS keypad protocol.

#### **10.1.1.1.2 The IWU mappings**

This protocol group has only one functional module.

The functional module (MES) is the test group designed for the IWU messages mapping.

#### **10.1.1.1.3 The profile specific NWK procedures**

This protocol group has only one functional module.

The functional module (CC) is the test group designed for the procedures defined in the base standard for covering the relationship between the NWK layer and the IWU for call control protocol.

#### **10.1.1.1.4 The profile specific DLC procedures**

This protocol group has only one functional module.

The functional module (SEG) is the test group designed for the procedures used in case of receipt of segmented messages.

### **10.1.1.2 Main test groups**

The main test groups are the capability group (CA), the valid behaviour group (BV), the inopportune behaviour group (BO) and the invalid behaviour group (BI).

**10.1.1.2.1 Capability (CA) tests**

This test sub group shall provide limited testing of the major IUT capabilities aiming to assure that the claimed capabilities are correctly supported, in accordance with the PICS.

**10.1.1.2.2 Valid Behaviour (BV) tests**

This test sub group shall verify that the IUT reacts in conformity with the standard, on receipt or exchange of a valid PDUs. Valid PDUs, means, that the exchange of messages and the content of the exchanged messages are considered as valid.

**10.1.1.2.3 Inopportune Behaviour (BO) tests**

This test sub group shall verify that the IUT is capable of a valid reaction, when an inopportune protocol event occurs. Such an event is syntactically correct but it occurs when it is not expected.

**10.1.1.2.4 Invalid Behaviour (BI) tests**

This test sub group shall verify that the IUT reacts in conformity with the standard, on receipt of a syntactically invalid PDU.

**10.2 Profile test purposes**

**10.2.1 TP definition conventions**

The TPs are defined following particular rules as shown in table 3.

**Table 3: TP definition rules**

TP Id according to the TP naming conventions	Reference.  Initial condition.  Stimulus.  Expected behaviour.
TP Id	The TP Id is a unique identifier it shall be specified according to the TP naming conventions defined in the subclause below.
Reference	The reference should contain the references of the subject to be validated by the actual TP (specification reference, clause, paragraph).
Condition	The condition defines in which initial state the IUT has to be to apply the actual TP.
Stimulus	The stimulus defines the test event to which the TP is related.
Expected behaviour	Definition of the events that are expected from the IUT to conform to the base specification.

**10.2.2 TP naming conventions**

The identifier of the TP is built according to table 4.

**Table 4: TP naming convention**

Identifier:	<b>TP-&lt;fm&gt;-x-&lt;nnn&gt;</b>		
<fm>	= functional module	CCCE	CC - call establishment
		CCCI	CC - call information
		CCCR	CC - call release
		SPSS	specific SS procedures
		FPIS	CISS functional protocol
		FPRS	CRSS functional protocol
		KPSS	CRSS keypad protocol
		MES	messages mapping
		CC	IWU specific CC procedures
		SEG	segmented messages
x	= Type of testing	C	CA, Capability Tests
		V	BV, Valid Behaviour Tests
		O	BO, Inopportune Behaviour Tests
		I	BI, Invalid Behaviour Tests
<nnn>	= sequential number	(000-999)	Test Purpose Number

**10.2.3 Sources of TP definitions**

All TPs are specified according to ETS 300 434-1 [6] and ETS 300 434-2 [7].

10.2.4 Test purposes for call establishment procedures

<p><b>TP-CCCE-C-000</b></p>	<p>ETS 300 434-1 [6], subclause 5.2.1.1.1, figure 6 ETS 300 705-2 [14] Profile specific ICS table C.11 item 1</p> <p>Initial state: The IWU is in state F00-U00.</p> <p>Check that the IUT manages rightly an outgoing call initiated by the PT with a DECT {CC-SETUP} including a &lt;&lt;CALLED-PARTY-NUMBER&gt;&gt;.</p>
<p><b>TP-CCCE-C-001</b></p>	<p>ETS 300 434-1 [6], subclause 5.2.1.1.1, figure 7 ETS 300 705-2 [14] Profile specific ICS table C.11 item 1</p> <p>Initial state: The IWU is in state F00-U00.</p> <p>Check that the IUT manages rightly an outgoing call initiated by the PT with a DECT {CC-SETUP}. No &lt;&lt;CALLED-PARTY-NUMBER&gt;&gt; is included in the {CC-SETUP}, and dialling information are sent in &lt;&lt;CALLED-PARTY-NUMBER&gt;&gt; of a DECT {CC-INFO} in PT OVERLAP SENDING state. The IUT has chosen to send an ISDN {SETUP} to the NT.</p>
<p><b>TP-CCCE-C-002</b></p>	<p>ETS 300 434-1 [6], subclause 5.2.1.1.1, figure 8 ETS 300 705-2 [14] Profile specific ICS table C.11 item 1</p> <p>Initial state: The IWU is in state F00-U00.</p> <p>Check that the IUT manages rightly an outgoing call initiated by the PT with a DECT {CC-SETUP}. No &lt;&lt;CALLED-PARTY-NUMBER&gt;&gt; is included in the {CC-SETUP}, and dialling information are sent in &lt;&lt;KEYPAD&gt;&gt; of consecutive DECT {CC-INFO} in PT OVERLAP SENDING state. The IUT has chosen to send an ISDN {SETUP} to the NT.</p>
<p><b>TP-CCCE-C-003</b></p>	<p>ETS 300 434-1 [6], subclause 5.2.1.1.1, figure 9 ETS 300 705-2 [14] Profile specific ICS table C.11 item 1</p> <p>Initial state: The IWU is in state F00-U00.</p> <p>Check that the IUT manages rightly an outgoing call initiated by the PT with a DECT {CC-SETUP}. No &lt;&lt;CALLED-PARTY-NUMBER&gt;&gt; is included in the {CC-SETUP}, and dialling information are sent in &lt;&lt;CALLED-PARTY-NUMBER&gt;&gt; of a DECT {CC-INFO} in PT OVERLAP SENDING state. The IUT has chosen to send back a DECT {CC-SETUP-ACK} to the PT.</p>
<p><b>TP-CCCE-C-004</b></p>	<p>ETS 300 434-1 [6], subclause 5.2.1.1.1, figure 10 ETS 300 705-2 [14] Profile specific ICS table C.11 item 1</p> <p>Initial state: The IWU is in state F00-U00.</p> <p>Check that the IUT manages rightly an outgoing call initiated by the PT with a DECT {CC-SETUP}. No &lt;&lt;CALLED-PARTY-NUMBER&gt;&gt; is included in the {CC-SETUP}, and dialling information are sent in &lt;&lt;KEYPAD&gt;&gt; of consecutive DECT {CC-INFO} in PT OVERLAP SENDING state. The IUT has chosen to send back a DECT {CC-SETUP-ACK} to the PT.</p>
<p><b>TP-CCCE-C-005</b></p>	<p>ETS 300 434-1 [6], subclause 5.2.1.1.2, figure 11 ETS 300 705-2 [14] Profile specific ICS table C.11 item 2</p> <p>Initial state: The IWU is in state F00-U00.</p> <p>Check that the IUT manages rightly an incoming call initiated by the NT with an ISDN {SETUP} containing enough dialling information to identify the destination.</p>

<b>TP-CCCE-C-006</b>	<p>ETS 300 434-1 [6], subclause 5.2.1.1.2, figure 12 ETS 300 705-2 [14] Profile specific ICS table C.11 item 2</p> <p>Initial state: The IWU is in state F00-U00.</p> <p>Check that the IUT manages rightly an incoming call, initiated by the NT with an ISDN {SETUP} not containing enough dialling information to identify the destination, by collecting (in Overlap Receiving state) the dialling information in the {INFORMATION} received after the {SETUP}.</p>
<b>TP-CCCE-C-007</b>	<p>ETS 300 434-1 [6], subclause 5.2.1.1.3 ETS 300 705-2 [14] Profile specific ICS table C.11 item 3</p> <p>Initial state: The IWU is in state F00-U00.</p> <p>Check that, in case an incoming call arrives with 2 &lt;&lt;BEARER-CAPABILITY&gt;&gt; and possibly 2 &lt;&lt;HIGH-LAYER-CAPABILITY&gt;&gt;, the IUT selects one set of attributes and forwards this chosen set to the PT.</p>

### 10.2.5 Test purposes for call information procedures

<b>TP-CCCI-C-000</b>	<p>ETS 300 434-1 [6], subclause 5.2.1.2. figure 13 Call Control (CC) - Call Information Procedures ETS 300 705-2 [14] Profile specific ICS table C.10 item 2</p> <p>Initial state: The IWU is in state F10-U10.</p> <p>Check that the IUT:       1- on receipt of an ISDN {INFORMATION}, sends a DECT {CC-INFO} to the PT and remains in state F10-U10.                                   2- on receipt of a DECT {CC-INFO}, sends an ISDN {INFORMATION} to the PT and remains in state F10-U10.</p>
----------------------	--



## 10.2.6 Test purposes for call release procedures

<b>TP-CCCR-C-000</b>	<p>ETS 300 434-1 [6], subclause 5.2.1.3.1, figure 14 Call release initiated by the DPS with CC-RELEASE message ETS 300 705-2 [14] Profile specific ICS table C.12 item 1</p> <p>Initial state: The IWU is in state F10-U10.</p> <p>Check that: the IUT, on receipt of an DECT {CC-RELEASE}, sends a ISDN {DISCONNECT} to the NT, waits for a response by an ISDN {RELEASE}, and on receipt of it, sends a DECT {CC-RELEASE-COM} to the PT, an ISDN {RELEASE-COM} to the NT and enters state F00-U00.</p>
<b>TP-CCCR-C-001</b>	<p>ETS 300 434-1 [6], subclause 5.2.1.3.1, figure 15 Call release initiated by the DPS with CC-RELEASE-COM message ETS 300 705-2 [14] Profile specific ICS table C.12 item 1</p> <p>Initial state: The IWU is in state F10-U10.</p> <p>Check that: the IUT, on receipt of an DECT {CC-RELEASE-COM}, sends a ISDN {DISCONNECT} to the NT, waits for a response by an ISDN {RELEASE}, and on receipt of it, sends an ISDN {RELEASE-COM} to the NT and enters state F00-U00.</p>
<b>TP-CCCR-C-002</b>	<p>ETS 300 434-1 [6], subclause 5.2.1.3.2, figure 16 Call release initiated by the NT with DISCONNECT message ETS 300 705-2 [14] Profile specific ICS table C.12 item 2</p> <p>Initial state: The IWU is in state F10-U10</p> <p>Check that the IUT, on receipt of an ISDN {DISCONNECT}, sends a DECT {CC-RELEASE} to the PT, waits for a response by a DECT {CC-RELEASE-COM}, and on receipt of it, sends an ISDN {RELEASE} to the NT, waits for a response by an ISDN {RELEASE-COM}, and on receipt of it enters state F00-U00.</p>
<b>TP-CCCR-C-003</b>	<p>ETS 300 434-1 [6], subclause 5.2.1.3.2, figure 17 Call release initiated by the NT with RELEASE message ETS 300 705-2 [14] Profile specific ICS table C.12 item 2</p> <p>Initial state: The IWU is in state F10-U10</p> <p>Check that the IUT, on receipt of an ISDN {RELEASE}, sends a DECT {CC-RELEASE-COM} to the PT, sends an ISDN {RELEASE-COM} to the NT, and enters state F00-U00.</p>
<b>TP-CCCR-C-004</b>	<p>ETS 300 434-1 [6], subclause 5.2.1.3.2, figure 18 Call release initiated by the NT with RELEASE-COM message ETS 300 705-2 [14] Profile specific ICS table C.12 item 2</p> <p>Initial state: The IWU is in state F10-U10</p> <p>Check that the IUT, on receipt of an ISDN {RELEASE-COM}, sends a DECT {CC-RELEASE-COM} to the PT, and enters state F00-U00.</p>

## 10.2.7 Test purposes for supplementary service specific procedures

<b>TP-SPSS-C-000</b>	<p>ETS 300 434-1 [6], subclause 5.2.2.5.1, 5.2.2.5.7, 5.2.4.1.22 ETS 300 705-2 [14] Profile specific ICS table C.15 item 1, item 5</p> <p>Initial state: The IWU is in state F00-U00 and DFS CLIP or SUB supplementary service procedure implemented.</p> <p>Check that: 1- the IUT, on receipt of an ISDN {SETUP} with &lt;&lt;sending complete&gt;&gt;, sends a DECT {CC-SETUP} to the PT, an ISDN {CALL-PROCEEDING} message to the NT and enters state F06-U09 (see Note 1). 2- The &lt;&lt;calling party number&gt;&gt; of the {SETUP} received is mapped to a &lt;&lt;calling party number &gt;&gt; of the {CC-SETUP} sent and the &lt;&lt;calling party subaddr.&gt;&gt; of the {SETUP} received is mapped to a &lt;&lt;IWU-to-IWU &gt;&gt; of the {CC-SETUP} sent.</p>
	<p>Note 1: Mapping of the ISDN &lt;&lt;Bearer-capability&gt;&gt;: Case (Info. transfer capability field of ISDN &lt;&lt;Bearer-capability&gt;&gt;) "Speech": DECT Basic-service IE is set to "default setup attributes" "3,1 kHz Audio": If progress indicator IE present &amp; set to "not ISDN originated" then DECT Basic-service IE is set to "default setup attributes" else Note 2 "Unr. Dig. Info.": Note 2 Other: Connection should be released</p> <p>Note 2: DECT Basic-service IE is set to "other" DECT Call attributes IE is created and added DECT End-to-end-compatibility IE is created with fields: sync./async. set with translation of ISDN Bearer-capability IE sync./async. field negotiation set with translation of ISDN Bearer-capability IE negotiation field user rate set with translation of ISDN Bearer-capability IE user rate field intermediate rate set with translation of ISDN Bearer-capability IE intermediate rate field NIC on Tx set with translation of ISDN Bearer-capability IE NIC on Tx field NIC on Rx set with translation of ISDN Bearer-capability IE NIC on Rx field flow control on Tx set with translation of ISDN Bearer-capability IE flow control on Tx field flow control on Rx set with translation of ISDN Bearer-capability IE flow control on Rx field number of stop bits set with translation of ISDN Bearer-capability IE number of stop bits field number of data bits set with translation of ISDN Bearer-capability IE number of data bits field parity information set with translation of ISDN Bearer-capability IE parity information field duplex mode set with translation of ISDN Bearer-capability IE duplex mode field modem type set with translation of ISDN Bearer-capability IE modem type field DECT IWU attributes IE is created with fields coding standard set with translation of ISDN Bearer-capability IE coding standard field info transfer capability set with translation of ISDN Bearer-capability IE info transfer capability field negotiation indicator set to "Negotiation not possible" external connec. type set to "Not applicable" transfer mode set with translation of ISDN Bearer-capability IE transfer mode field info transfer rate set with translation of ISDN Bearer-capability IE info transfer rate field protocol ID coding set with translation of ISDN Bearer-capability IE protocol ID coding user protocol ID set with translation of ISDN Bearer-capability IE user info layer 1 prot. field L3 protocol ID set with translation of ISDN Bearer-capability IE user info layer 3 prot. field L2 protocol ID set with translation of ISDN Bearer-capability IE user info layer 2 prot. field</p>

<p><b>TP-SPSS-C-001</b></p>	<p>ETS 300 434-1 [6], subclause 5.2.2.5.2, 5.2.4.2.11 ETS 300 705-2 [14] Profile specific ICS table C.15 item 2</p> <p>Initial state: The IWU is in state F00-U00 and DFS CLIR supplementary service procedure implemented.</p> <p>Check that: 1- the IUT, on receipt of an DECT {CC-SETUP}, sends a ISDN {SETUP} to the PT and enters state F01-U01. 2- The &lt;&lt;CALLING-PARTY-NUMBER&gt;&gt; of the {CC-SETUP} received is mapped to a &lt;&lt;CALLING-PARTY-NUMBER&gt;&gt; of the {SETUP} sent.</p>
<p><b>TP-SPSS-C-002</b></p>	<p>ETS 300 434-1 [6], subclause 5.2.2.5.3, 5.2.4.1.6 ETS 300 705-2 [14] Profile specific ICS table C.15 item 3</p> <p>Initial state: The IWU is in state F02-U02 and DFS COLP supplementary service procedure implemented.</p> <p>Check that: 1- the IUT, on receipt of an ISDN {CONNECT}, sends a DECT {CC-CONNECT} to the PT and enters state F10-U10. 2- The whole &lt;&lt;connected party number&gt;&gt; and &lt;&lt;connected party sub-address &gt;&gt; of the {CONNECT} received are mapped to a &lt;&lt;IWU-to-IWU &gt;&gt; of the {CC-CONNECT} sent.</p>
<p><b>TP-SPSS-C-003</b></p>	<p>ETS 300 434-1 [6], subclause 5.2.2.5.4, 5.2.4.2.2 ETS 300 705-2 [14] Profile specific ICS table C.15 item 4</p> <p>Initial state: The IWU is in state F07-U07 and DFS COLR supplementary service procedure implemented.</p> <p>Check that: 1- the IUT, on receipt of a DECT {CC-CONNECT}, sends an ISDN {CONNECT} to the NT and enters state F07-U08. 2- The &lt;&lt;IWU-to-IWU &gt;&gt; of the DECT {CC-CONNECT} received is mapped to a &lt;&lt;connected party number&gt;&gt; of the ISDN {CONNECT} sent.</p>
<p><b>TP-SPSS-C-004</b></p>	<p>ETS 300 434-1 [6], subclause 5.2.2.5.9 ETS 300 705-2 [14] Profile specific ICS table C.15 item 7</p> <p>Initial state: The IWU is in state F00-U00 and DFS CW supplementary service procedure implemented.</p> <p>Check that: 1- the IUT, on receipt of an ISDN {SETUP} with &lt;&lt;sending complete&gt;&gt;, sends a DECT {CC-SETUP} to the PT, an ISDN {CALL-PROCEEDING} message to the NT and enters state F01-U01 (see Note 1 of TP-SPSS-C-000). 2- The &lt;&lt;channel identification&gt;&gt; of the {SETUP} received is mapped to a &lt;&lt;IWU-to-IWU &gt;&gt; of the {CC-SETUP} sent.</p>
<p><b>TP-SPSS-C-005</b></p>	<p>ETS 300 434-1 [6], subclause 5.2.2.5.17 ETS 300 705-2 [14] Profile specific ICS table C.15 item 8</p> <p>Initial state: The IWU is in state F00-U00 and DFS UUS1 supplementary service procedure implemented.</p> <p>Check that, during establishment of an outgoing call, for each of the DECT messages containing an ISDN &lt;&lt;USER-to-USER&gt;&gt; coded in the DECT &lt;&lt;IWU-to-IWU&gt;&gt;, the IUT adds an ISDN &lt;&lt;USER-to-USER&gt;&gt; in the corresponding ISDN message.</p>

<b>TP-SPSS-C-006</b>	<p>ETS 300 434-1 [6], subclause 5.2.2.5.17 ETS 300 705-2 [14] Profile specific ICS table C.15 item 8</p> <p>Initial state: The IWU is in state F00-U00 and DFS UUS1 supplementary service procedure implemented.</p> <p>Check that, during establishment of an incoming call, for each of the ISDN messages containing an ISDN &lt;&lt;USER-to-USER&gt;&gt; element, the IUT maps the ISDN &lt;&lt;USER-to-USER&gt;&gt; in an &lt;&lt;IWU-to-IWU&gt;&gt; in the corresponding DECT message.</p>
<b>TP-SPSS-C-007</b>	<p>ETS 300 434-1 [6], subclause 5.2.2.5.18 ETS 300 705-2 [14] Profile specific ICS table C.15 item 9</p> <p>Initial state: The IWU is in state F01-U01 and DFS UUS2 supplementary service procedure implemented.</p> <p>Check that the IUT, on receipt of an ISDN {USER-INFORMATION}, sends a DECT {CC-INFO} to the PT. The whole ISDN message, excluding the protocol discriminator and call reference, is mapped into a DECT &lt;&lt;IWU-to-IWU&gt;&gt; of the {CC-INFO}.</p>
<b>TP-SPSS-C-008</b>	<p>ETS 300 434-1 [6], subclause 5.2.2.5.18, 5.2.4.2.7 ETS 300 705-2 [14] Profile specific ICS table C.15 item 9</p> <p>Initial state: The IWU is in state F01-U01 and DFS UUS2 supplementary service procedure implemented.</p> <p>Check that the IUT, on receipt of a DECT {CC-INFO}, and if an ISDN {USER-INFORMATION} is coded in the DECT &lt;&lt;IWU-to-IWU&gt;&gt; element of the DECT {CC-INFO} message, sends an ISDN {USER-INFORMATION} to the NT.</p>
<b>TP-SPSS-C-009</b>	<p>ETS 300 434-1 [6], subclause 5.2.2.5.19 ETS 300 705-2 [14] Profile specific ICS table C.15 item 10</p> <p>Initial state: The IWU is in state F10-U10 and DFS UUS3 supplementary service procedure implemented.</p> <p>Check that the IUT, on receipt of an ISDN {USER-INFORMATION}, sends a DECT {CC-INFO} to the PT. The whole ISDN message, excluding the protocol discriminator and call reference, is mapped into a DECT &lt;&lt;IWU-to-IWU&gt;&gt; of the {CC-INFO}.</p>
<b>TP-SPSS-C-010</b>	<p>ETS 300 434-1 [6], subclause 5.2.2.5.19, 5.2.4.2.7 ETS 300 705-2 [14] Profile specific ICS table C.15 item 10</p> <p>Initial state: The IWU is in state F10-U10 and DFS UUS3 supplementary service procedure implemented.</p> <p>Check that the IUT, on receipt of a DECT {CC-INFO}, and if an ISDN {USER-INFORMATION} is coded in the DECT &lt;&lt;IWU-to-IWU&gt;&gt; element of the DECT {CC-INFO} message, sends an ISDN {USER-INFORMATION} to the NT.</p>
<b>TP-SPSS-C-011</b>	<p>ETS 300 434-1 [6], subclause 5.2.2.5.19 ETS 300 705-2 [14] Profile specific ICS table C.15 item 10</p> <p>Initial state: The IWU is in state F10-U10 and DFS UUS3 supplementary service procedure implemented.</p> <p>Check that the IUT, on receipt of an ISDN {CONGESTION-CONTROL}, sends a DECT {CC-INFO} to the PT. The whole ISDN message, excluding the protocol discriminator and call reference, is mapped into a DECT &lt;&lt;IWU-to-IWU&gt;&gt; of the {CC-INFO}.</p>

<b>TP-SPSS-C-012</b>	ETS 300 434-1 [6], subclause 5.2.2.5.21 ETS 300 705-2 [14] Profile specific ICS table C.15 item 11  Initial state: The IWU is in state F00-U00 and DFS CCBS supplementary service procedure implemented.  Check that: 1- the IUT, on receipt of a DECT {CC-SETUP}, sends an ISDN {SETUP} to the PT and enters state F01-U01. 2- A <<CALLING-PARTY-NUMBER>> or a <<CALLING-PARTY-SUBADDRESS>> is included by the IUT in the {SETUP} sent to uniquely identify the PT.
<b>TP-SPSS-C-013</b>	ETS 300 434-1 [6], subclause 5.2.2.5.21 ETS 300 705-2 [14] Profile specific ICS table C.15 item 11  Initial state: The IWU is in state F10-U10 and DFS CCBS supplementary service procedure implemented.  Check that the IUT, on receipt of an ISDN connectionless {FACILITY}, analyses the <<CALLED-PARTY-NUMBER>> and/or the <<CALLED-PARTY-SUBADDRESS>> to identify the PT and forwards the corresponding DECT {FACILITY} to that identified PT.

## 10.2.8 Test purposes for CISS functional protocol procedures

<p><b>TP-FPIS-C-000</b></p>	<p>ETS 300 434-1 [6], subclause 5.2.2.4.1, 5.2.4.2.12 ETS 300 705-2 [14] Profile specific ICS table C.14 item 1</p> <p>Initial state: The IWU is in state F10-U10</p> <p>Check that the IUT, on receipt of a DECT {CISS-REGISTER}, sends an ISDN {REGISTER} to the NT.</p>
<p><b>TP-FPIS-C-001</b></p>	<p>ETS 300 434-1 [6], subclause 5.2.2.4.1, 5.2.4.1.17 ETS 300 705-2 [14] Profile specific ICS table C.14 item 1</p> <p>Initial state: The IWU is in state F10-U10</p> <p>Check that the IUT, on receipt of an ISDN {REGISTER}, sends a DECT {CISS-REGISTER} to the PT.</p>
<p><b>TP-FPIS-C-002</b></p>	<p>ETS 300 434-1 [6], subclause 5.2.2.4.1, 5.2.4.2.13 ETS 300 705-2 [14] Profile specific ICS table C.14 item 1</p> <p>Initial state: The IWU is in state F10-U10 and a known CISS connection is established.</p> <p>Check that the IUT, on receipt of a DECT {CISS-RELEASE-COM} of the known CISS connection, sends an ISDN {CISS-RELEASE} to the NT.</p>
<p><b>TP-FPIS-C-003</b></p>	<p>ETS 300 434-1 [6], subclause 5.2.2.4.1, 5.2.4.1.3 ETS 300 705-2 [14] Profile specific ICS table C.14 item 1</p> <p>Initial state: The IWU is in state F10-U10 and a known CISS connection is established.</p> <p>Check that the IUT, on receipt of an ISDN {CISS-RELEASE} of the known CISS connection, sends a DECT {CISS-RELEASE-COM} to the PT.</p>
<p><b>TP-FPIS-C-004</b></p>	<p>ETS 300 434-1 [6], subclause 5.2.2.4.1, 5.2.4.2.14 ETS 300 705-2 [14] Profile specific ICS table C.14 item 1</p> <p>Initial state: The IWU is in state F10-U10 and a known CISS connection is established.</p> <p>Check that the IUT, on receipt of a DECT {FACILITY ciss} for the known CISS connection, sends an ISDN {FACILITY ciss} to the NT.</p>
<p><b>TP-FPIS-C-005</b></p>	<p>ETS 300 434-1 [6], subclause 5.2.2.4.1, 5.2.4.1.9 ETS 300 705-2 [14] Profile specific ICS table C.14 item 1</p> <p>Initial state: The IWU is in state F10-U10 and a known CISS connection is established.</p> <p>Check that the IUT, on receipt of an ISDN {FACILITY ciss} for the known CISS connection, sends a DECT {FACILITY ciss} to the PT</p>
<p><b>TP-FPIS-C-006</b></p>	<p>ETS 300 434-1 [6], subclause 5.2.2.4.2, figure 20 ETS 300 705-2 [14] Profile specific ICS table C.14 item 2</p> <p>Initial state: No requirement is necessary for the initial state of the IUT IWU. Nevertheless, it is important to have a defined state and for this reason the IWU is forced in Null state (F00-U00).</p> <p>Check that the IUT:</p> <ol style="list-style-type: none"> <li>1- on receipt of a connectionless {FACILITY} from the NT, sends a {LCE-PAGE_REQUEST} to the PT, and waits for the {LCE-PAGE-RESPONSE} from the PT.</li> <li>2- On receipt of the PT response, the IUT maps the ISDN message to a DECT {FACILITY-ciss} with a TI value set to 6 (connectionless value) and sends it to the PT.</li> </ol>

10.2.9 Test purposes for CRSS functional protocol procedures

<p><b>TP-FPRS-C-000</b></p>	<p>ETS 300 434-1 [6], subclause 5.2.2.3.1, 5.2.4.2.11 ETS 300 705-2 [14] Profile specific ICS table C.13 item 1</p> <p>Initial state: The IWU is in state F00-U00.</p> <p>Check that the IUT, on receipt of an outgoing call, initiated by the PT with an DECT {CC-SETUP} including a &lt;&lt;CALLED-PARTY-NUMBER&gt;&gt;, sends an ISDN {SETUP} to the NT. The &lt;&lt;FACILITY&gt;&gt; element contained in the DECT {CC-SETUP} is mapped to a &lt;&lt;FACILITY&gt;&gt; element in the ISDN {SETUP}.</p>
<p><b>TP-FPRS-C-001</b></p>	<p>ETS 300 434-1 [6], subclause 5.2.2.3.1, 5.2.4.1.6 ETS 300 705-2 [14] Profile specific ICS table C.13 item 1</p> <p>Initial state: The IWU is in state F00-U00.</p> <p>Check that the IUT, during establishment of an outgoing call, initiated by the PT, on receipt of an ISDN {CONNECT} from the NT, sends a DECT {CC-CONNECT} to the PT. The &lt;&lt;FACILITY&gt;&gt; element contained in the ISDN {CONNECT} is mapped to a &lt;&lt;FACILITY&gt;&gt; element in the DECT {CC-CONNECT}.</p>
<p><b>TP-FPRS-C-002</b></p>	<p>ETS 300 434-1 [6], subclause 5.2.2.3.1, 5.2.4.1.1 ETS 300 705-2 [14] Profile specific ICS table C.13 item 1</p> <p>Initial state: The IWU is in state F00-U00.</p> <p>Check that the IUT, during establishment of an outgoing call, initiated by the PT, on receipt of an ISDN {ALERTING} from the NT, sends a DECT {CC-ALERTING} to the PT. The &lt;&lt;FACILITY&gt;&gt; element contained in the ISDN {ALERTING} is mapped to a &lt;&lt;FACILITY&gt;&gt; element in the DECT {CC-ALERTING}.</p>
<p><b>TP-FPRS-C-003</b></p>	<p>ETS 300 434-1 [6], subclause 5.2.2.3.1, 5.2.4.1.2 ETS 300 705-2 [14] Profile specific ICS table C.13 item 1</p> <p>Initial state: The IWU is in state F00-U00.</p> <p>Check that the IUT, during establishment of an outgoing call, initiated by the PT, on receipt of an ISDN {CALL-PROCEEDING} from the NT, sends a DECT {CC-CALL-PROCEEDING} to the PT. The &lt;&lt;FACILITY&gt;&gt; element contained in the ISDN {CALL-PROCEEDING} is mapped to a &lt;&lt;FACILITY&gt;&gt; element in the DECT {CC-CALL-PROCEEDING}.</p>
<p><b>TP-FPRS-C-004</b></p>	<p>ETS 300 434-1 [6], subclause 5.2.2.3.1, 5.2.4.1.16 ETS 300 705-2 [14] Profile specific ICS table C.13 item 1</p> <p>Initial state: The IWU is in state F00-U00.</p> <p>Check that the IUT, during establishment of an outgoing call, initiated by the PT, on receipt of an ISDN {PROGRESS} from the NT, sends a DECT {CC-INFO} to the PT. The &lt;&lt;FACILITY&gt;&gt; element contained in the ISDN {PROGRESS} is mapped to a &lt;&lt;FACILITY&gt;&gt; element in the DECT {CC-INFO}.</p>
<p><b>TP-FPRS-C-005</b></p>	<p>ETS 300 434-1 [6], subclause 5.2.2.3.2, 5.2.4.2.2 ETS 300 705-2 [14] Profile specific ICS table C.13 item 1</p> <p>Initial state: The IWU is in state F00-U00.</p> <p>Check that the IUT, during establishment of an incoming call, initiated by the NT, on receipt of a DECT {CC-CONNECT} from the PT, sends an ISDN {CONNECT} to the NT. The &lt;&lt;FACILITY&gt;&gt; element contained in the DECT {CC-CONNECT} is mapped to a &lt;&lt;FACILITY&gt;&gt; element in the ISDN {CONNECT}.</p>

<b>TP-FPRS-C-006</b>	<p>ETS 300 434-1 [6], subclause 5.2.2.3.2, 5.2.4.2.1 ETS 300 705-2 [14] Profile specific ICS table C.13 item 1</p> <p>Initial state: The IWU is in state F00-U00.</p> <p>Check that the IUT, during establishment of an incoming call, initiated by the NT, on receipt of a DECT {CC-ALERTING} from the PT, sends an ISDN {ALERTING} to the NT. The &lt;&lt;FACILITY&gt;&gt; element contained in the DECT {CC-ALERTING} is mapped to a &lt;&lt;FACILITY&gt;&gt; element in the ISDN {ALERTING}.</p>
<b>TP-FPRS-C-007</b>	<p>ETS 300 434-1 [6], subclause 5.2.2.3.2, 5.2.4.1.22 ETS 300 705-2 [14] Profile specific ICS table C.13 item 1</p> <p>Initial state: The IWU is in state F00-U00.</p> <p>Check that the IUT, on receipt of an incoming call, initiated by the NT with an ISDN {SETUP} containing enough dialling information to identify the destination, sends a DECT {CC-SETUP} to the PT. The &lt;&lt;FACILITY&gt;&gt; element contained in the ISDN {SETUP} is mapped to a &lt;&lt;FACILITY&gt;&gt; element in the DECT {CC-SETUP}.</p>
<b>TP-FPRS-C-008</b>	<p>ETS 300 434-1 [6], subclause 5.2.1.3.1, figure 14, 5.2.2.3.4, 5.2.4.2.8, 5.2.4.1.18 Call release initiated by the DPS with CC-RELEASE message ETS 300 705-2 [14] Profile specific ICS table C.13 item 1</p> <p>Initial state: The IWU is in state F10-U10.</p> <p>Check that: the IUT, on receipt of an DECT {CC-RELEASE}, sends a ISDN {DISCONNECT} to the NT, waits for a response by an ISDN {RELEASE}, and on receipt of it, sends a DECT {CC-RELEASE-COM} to the PT, an ISDN {RELEASE-COM} to the NT and enters state F00-U00. The &lt;&lt;FACILITY&gt;&gt; element contained in the DECT {CC-RELEASE} is mapped to a &lt;&lt;FACILITY&gt;&gt; element in the ISDN {DISCONNECT}. The &lt;&lt;FACILITY&gt;&gt; element contained in the ISDN {RELEASE} is mapped to a &lt;&lt;FACILITY&gt;&gt; element in the DECT {CC-RELEASE-COM}.</p>
<b>TP-FPRS-C-009</b>	<p>ETS 300 434-1 [6], subclause 5.2.1.3.1, figure 15, 5.2.2.3.4, 5.2.4.2.10, 5.2.4.1.18 Call release initiated by the DPS with CC-RELEASE-COM message ETS 300 705-2 [14] Profile specific ICS table C.13 item 1</p> <p>Initial state: The IWU is in state F10-U10.</p> <p>Check that: the IUT, on receipt of an DECT {CC-RELEASE-COM}, sends a ISDN {DISCONNECT} to the NT, waits for a response by an ISDN {RELEASE}, and on receipt of it, sends an ISDN {RELEASE-COM} to the NT and enters state F00-U00. The &lt;&lt;FACILITY&gt;&gt; element contained in the DECT {CC-RELEASE-COM} is mapped to a &lt;&lt;FACILITY&gt;&gt; element in the ISDN {DISCONNECT}. The &lt;&lt;FACILITY&gt;&gt; element contained in the ISDN {RELEASE} is mapped to a &lt;&lt;FACILITY&gt;&gt; element in the DECT {CC-RELEASE-COM}.</p>



<p><b>TP-FPRS-C-010</b></p>	<p>ETS 300 434-1 [6], subclause 5.2.1.3.2, figure 16, 5.2.2.3.4, 5.2.4.2.9, 5.2.4.1.8 Call release initiated by the NT with DISCONNECT message ETS 300 705-2 [14] Profile specific ICS table C.13 item 1</p> <p>Initial state: The IWU is in state F10-U10</p> <p>Check that the IUT, on receipt of an ISDN {DISCONNECT}, sends a DECT {CC-RELEASE} to the PT, waits for a response by a DECT {CC-RELEASE-COM}, and on receipt of it, sends an ISDN {RELEASE} to the NT, waits for a response by an ISDN {RELEASE-COM}, and on receipt of it enters state F00-U00. The &lt;&lt;FACILITY&gt;&gt; element contained in the ISDN {DISCONNECT} is mapped to a &lt;&lt;FACILITY&gt;&gt; element in the DECT {CC-RELEASE} and the message type ISDN {DISCONNECT} is mapped in an &lt;&lt;IWU-to-IWU&gt;&gt; of the DECT {CC-RELEASE}.</p> <p>The &lt;&lt;FACILITY&gt;&gt; element contained in the DECT {CC-RELEASE-COM} is mapped to a &lt;&lt;FACILITY&gt;&gt; element in the ISDN {RELEASE}.</p>
<p><b>TP-FPRS-C-011</b></p>	<p>ETS 300 434-1 [6], subclause 5.2.1.3.2, figure 17, 5.2.2.3.4, 5.2.4.1.18 Call release initiated by the NT with RELEASE message ETS 300 705-2 [14] Profile specific ICS table C.13 item 1</p> <p>Initial state: The IWU is in state F10-U10</p> <p>Check that the IUT, on receipt of an ISDN {RELEASE}, sends a DECT {CC-RELEASE-COM} to the PT, sends an ISDN {RELEASE-COM} to the NT, and enters state F00-U00. The &lt;&lt;FACILITY&gt;&gt; element contained in the ISDN {RELEASE} is mapped to a &lt;&lt;FACILITY&gt;&gt; element in the DECT {CC-RELEASE-COM}.</p>
<p><b>TP-FPRS-C-012</b></p>	<p>ETS 300 434-1 [6], subclause 5.2.1.3.2, figure 18, 5.2.2.3.4, 5.2.4.1.19 Call release initiated by the NT with RELEASE-COM message ETS 300 705-2 [14] Profile specific ICS table C.13 item 1</p> <p>Initial state: The IWU is in state F10-U10</p> <p>Check that the IUT, on receipt of an ISDN {RELEASE-COM}, sends a DECT {CC-RELEASE-COM} to the PT, and enters state F00-U00. The &lt;&lt;FACILITY&gt;&gt; element contained in the ISDN {RELEASE-COM} is mapped to a &lt;&lt;FACILITY&gt;&gt; element in the DECT {CC-RELEASE-COM}.</p>
<p><b>TP-FPRS-C-013</b></p>	<p>ETS 300 434-1 [6], subclause 5.2.2.3.5, 5.2.4.1.10, 5.2.4.2.15 ETS 300 705-2 [14] Profile specific ICS table C.13 item 1</p> <p>Initial state: The IWU is in state F10-U10</p> <p>Check that the IUT:</p> <ol style="list-style-type: none"> <li>1- on receipt of an ISDN {FACILITY crss} from the NT, sends a DECT {FACILITY crss} to the PT. The &lt;&lt;FACILITY&gt;&gt; element contained in the ISDN {FACILITY crss} is mapped to a &lt;&lt;FACILITY&gt;&gt; element in the DECT {FACILITY crss}.</li> <li>2- on receipt of a DECT {FACILITY crss} from the PT, sends an ISDN {FACILITY crss} to the NT. The &lt;&lt;FACILITY&gt;&gt; element contained in the DECT {FACILITY crss} is mapped to a &lt;&lt;FACILITY&gt;&gt; element in the ISDN {FACILITY crss}.</li> </ol>
<p><b>TP-FPRS-C-014</b></p>	<p>ETS 300 434-1 [6], subclause 5.2.2.3.7, 5.2.4.1.11, 5.2.4.2.16 ETS 300 705-2 [14] Profile specific ICS table C.13 item 2</p> <p>Initial state: The IWU is in state F10-U10</p> <p>Check that the IUT:</p> <ol style="list-style-type: none"> <li>1- on receipt of a DECT {HOLD} for the existing call, sends an ISDN {HOLD} to the NT and waits for an ISDN {HOLD-ACK} response form the NT.</li> <li>2- On receipt of the NT response, the IUT maps the ISDN {HOLD-ACK} response to a DECT {HOLD-ACK} and sends it to the PT.</li> </ol>

<b>TP-FPRS-C-015</b>	<p>ETS 300 434-1 [6], subclause 5.2.2.3.7, 5.2.4.1.12, 5.2.4.2.16 ETS 300 705-2 [14] Profile specific ICS table C.13 item 2</p> <p>Initial state: The IWU is in state F10-U10</p> <p>Check that the IUT:</p> <ol style="list-style-type: none"> <li>1- on receipt of a DECT {HOLD} for the existing held call, sends an ISDN {HOLD} to the NT and waits for an ISDN {HOLD-REJ} response from the NT.</li> <li>2- On receipt of the NT response, the IUT maps the ISDN {HOLD-REJ} response to a DECT {HOLD-REJ} and sends it to the PT.</li> </ol>
<b>TP-FPRS-C-016</b>	<p>ETS 300 434-1 [6], subclause 5.2.2.3.7, 5.2.4.1.20, 5.2.4.2.17 ETS 300 705-2 [14] Profile specific ICS table C.13 item 2</p> <p>Initial state: The IWU is in state F10-U10</p> <p>Check that the IUT:</p> <ol style="list-style-type: none"> <li>1- on receipt of a DECT {RETRIEVE} for an held call, sends an ISDN {RETRIEVE} to the NT and waits for an ISDN {RETRIEVE-ACK} response from the NT.</li> <li>2- On receipt of the NT response, the IUT maps the ISDN {RETRIEVE-ACK} response to a DECT {RETRIEVE-ACK} and sends it to the PT.</li> </ol>
<b>TP-FPRS-C-017</b>	<p>ETS 300 434-1 [6], subclause 5.2.2.3.7, 5.2.4.1.21, 5.2.4.2.17 ETS 300 705-2 [14] Profile specific ICS table C.13 item 2</p> <p>Initial state: The IWU is in state F10-U10</p> <p>Check that the IUT:</p> <ol style="list-style-type: none"> <li>1- on receipt of a DECT {RETRIEVE} for a normal call, sends an ISDN {RETRIEVE} to the NT and waits for an ISDN {RETRIEVE-REJ} response from the NT.</li> <li>2- On receipt of the NT response, the IUT maps the ISDN {RETRIEVE-REJ} response to a DECT {RETRIEVE-REJ} and sends it to the PT.</li> </ol>
<b>TP-FPRS-C-018</b>	<p>ETS 300 434-1 [6], subclause 5.2.2.3.8, 5.2.4.1.6 ETS 300 705-2 [14] Profile specific ICS table C.13 item 3</p> <p>Initial state: The IWU is in state F00-U00.</p> <p>Check that the IUT, during establishment of an outgoing call, initiated by the PT, on receipt of an ISDN {CONNECT} from the NT, sends a DECT {CC-CONNECT} to the PT.</p> <p>The entire &lt;&lt;NOTIFICATION-INDICATOR&gt;&gt; element contained in the ISDN {CONNECT} is mapped to an &lt;&lt;IWU-to-IWU&gt;&gt; element in the DECT {CC-CONNECT}.</p>
<b>TP-FPRS-C-019</b>	<p>ETS 300 434-1 [6], subclause 5.2.2.3.8, 5.2.4.1.1 ETS 300 705-2 [14] Profile specific ICS table C.13 item 3</p> <p>Initial state: The IWU is in state F00-U00.</p> <p>Check that the IUT, during establishment of an outgoing call, initiated by the PT, on receipt of an ISDN {ALERTING} from the NT, sends a DECT {CC-ALERTING} to the PT.</p> <p>The entire &lt;&lt;NOTIFICATION-INDICATOR&gt;&gt; element contained in the ISDN {ALERTING} is mapped to an &lt;&lt;IWU-to-IWU&gt;&gt; element in the DECT {CC-ALERTING}.</p>

<p><b>TP-FPRS-C-020</b></p>	<p>ETS 300 434-1 [6], subclause 5.2.2.3.8, 5.2.4.1.2 ETS 300 705-2 [14] Profile specific ICS table C.13 item 3</p> <p>Initial state: The IWU is in state F00-U00.</p> <p>Check that the IUT, during establishment of an outgoing call, initiated by the PT, on receipt of an ISDN {CALL-PROCEEDING} from the NT, sends a DECT {CC-CALL-PROCEEDING} to the PT. The entire &lt;&lt;NOTIFICATION-INDICATOR&gt;&gt; element contained in the ISDN {CALL-PROCEEDING} is mapped to an &lt;&lt;IWU-to-IWU&gt;&gt; element in the DECT {CC-CALL-PROCEEDING}.</p>
<p><b>TP-FPRS-C-021</b></p>	<p>ETS 300 434-1 [6], subclause 5.2.2.3.8, 5.2.4.1.16 ETS 300 705-2 [14] Profile specific ICS table C.13 item 3</p> <p>Initial state: The IWU is in state F00-U00.</p> <p>Check that the IUT, during establishment of an outgoing call, initiated by the PT, on receipt of an ISDN {PROGRESS} from the NT, sends a DECT {CC-INFO} to the PT. The entire &lt;&lt;NOTIFICATION-INDICATOR&gt;&gt; element contained in the ISDN {PROGRESS} is mapped to an &lt;&lt;IWU-to-IWU&gt;&gt; element in the DECT {CC-INFO}.</p>
<p><b>TP-FPRS-C-022</b></p>	<p>ETS 300 434-1 [6], subclause 5.2.2.3.9, 5.2.4.1.7 ETS 300 705-2 [14] Profile specific ICS table C.13 item 3</p> <p>Initial state: The IWU is in state F00-U00.</p> <p>Check that the IUT, during establishment of an incoming call, initiated by the NT, on receipt of an ISDN {CONNECT-ACK} from the NT, sends an DECT {CC-CONNECT-ACK} to the PT. The entire &lt;&lt;NOTIFICATION-INDICATOR&gt;&gt; element contained in the ISDN {CONNECT-ACK} is mapped to an &lt;&lt;IWU-to-IWU&gt;&gt; element in the DECT {CC-CONNECT-ACK}.</p>
<p><b>TP-FPRS-C-023</b></p>	<p>ETS 300 434-1 [6], subclause 5.2.2.3.9, 5.2.4.1.22 ETS 300 705-2 [14] Profile specific ICS table C.13 item 3</p> <p>Initial state: The IWU is in state F00-U00.</p> <p>Check that the IUT, on receipt of an incoming call, initiated by the NT with an ISDN {SETUP} containing enough dialling information to identify the destination, sends a DECT {CC-SETUP} to the PT. The entire &lt;&lt;NOTIFICATION-INDICATOR&gt;&gt; element contained in the ISDN {SETUP} is mapped to an &lt;&lt;IWU-to-IWU&gt;&gt; element in the DECT {CC-SETUP}.</p>
<p><b>TP-FPRS-C-024</b></p>	<p>ETS 300 434-1 [6], subclause 5.2.1.3.2, figure 16, 5.2.2.3.11, 5.2.4.2.9, 5.2.4.1.8 Call release initiated by the NT with DISCONNECT message ETS 300 705-2 [14] Profile specific ICS table C.13 item 3</p> <p>Initial state: The IWU is in state F10-U10</p> <p>Check that the IUT, on receipt of an ISDN {DISCONNECT}, sends a DECT {CC-RELEASE} to the PT, waits for a response by a DECT {CC-RELEASE-COM}, and on receipt of it, sends an ISDN {RELEASE} to the NT, waits for a response by an ISDN {RELEASE-COM}, and on receipt of it enters state F00-U00. The entire &lt;&lt;NOTIFICATION-INDICATOR&gt;&gt; element contained in the ISDN {DISCONNECT} is mapped to an &lt;&lt;IWU-to-IWU&gt;&gt; element in the DECT {CC-RELEASE} and the message type ISDN {DISCONNECT} is mapped in another &lt;&lt;IWU-to-IWU&gt;&gt; of the DECT {CC-RELEASE}.</p>

<b>TP-FPRS-C-025</b>	<p>ETS 300 434-1 [6], subclause 5.2.1.3.2, figure 18, 5.2.2.3.11, 5.2.4.1.19  Call release initiated by the NT with RELEASE-COM message  ETS 300 705-2 [14] Profile specific ICS table C.13 item 3</p> <p>Initial state: The IWU is in state F10-U10</p> <p>Check that the IUT, on receipt of an ISDN {RELEASE-COM}, sends a DECT {CC-RELEASE-COM} to the PT, and enters state F00-U00.  The entire &lt;&lt;NOTIFICATION-INDICATOR&gt;&gt; element contained in the ISDN {RELEASE-COM} is mapped to an &lt;&lt;IWU-to-IWU&gt;&gt; element in the DECT {CC-RELEASE-COM}.</p>
<b>TP-FPRS-C-026</b>	<p>ETS 300 434-1 [6], subclause 5.2.2.3.12, 5.2.4.1.15  ETS 300 705-2 [14] Profile specific ICS table C.13 item 3</p> <p>Initial state: The IWU is in state F00-U00.</p> <p>Check that the IUT, during establishment of an incoming call, initiated by the NT, on receipt of an ISDN {NOTIFY} from the NT, sends an DECT {CC-INFO} to the PT.  The entire &lt;&lt;NOTIFICATION-INDICATOR&gt;&gt; element contained in the ISDN {NOTIFY} is mapped to an &lt;&lt;IWU-to-IWU&gt;&gt; element in the DECT {CC-INFO}.</p>
<b>TP-FPRS-C-027</b>	<p>ETS 300 434-1 [6], subclause 5.2.2.3.12, 5.2.4.1.10  ETS 300 705-2 [14] Profile specific ICS table C.13 item 3</p> <p>Initial state: The IWU is in state F00-U00.</p> <p>Check that the IUT, during establishment of an incoming call, initiated by the NT, on receipt of an ISDN {FACILITY-crss} from the NT, sends an DECT {FACILITY-crss} to the PT.  The entire &lt;&lt;NOTIFICATION-INDICATOR&gt;&gt; element contained in the ISDN {FACILITY-crss} is mapped to an &lt;&lt;IWU-to-IWU&gt;&gt; element in the DECT {FACILITY-crss}.</p>

## 10.2.10 Test purposes for CRSS keypad protocol procedures

<b>TP-KPSS-C-000</b>	<p>ETS 300 434-1 [6], subclause 5.2.1.1.1, 5.2.2.1, figure 8 ETS 300 705-2 [14] Profile specific ICS table C.10 item 4</p> <p>Initial state: The IWU is in state F00-U00.</p> <p>Check that the IUT manages rightly an outgoing call initiated by the PT with a DECT {CC-SETUP}. No &lt;&lt;CALLED-PARTY-NUMBER&gt;&gt; is included in the {CC-SETUP}, and dialling information are sent in &lt;&lt;KEYPAD&gt;&gt; of consecutive DECT {CC-INFO} in PT OVERLAP SENDING state. The IUT has chosen to send an ISDN {SETUP} to the NT (case a). The supplementary service key data of the DECT &lt;&lt;KEYPAD&gt;&gt; in the DECT {CC-SETUP} and {CC-INFO} are mapped to an ISDN &lt;&lt;KEYPAD-FACILITY&gt;&gt; in the ISDN {SETUP} and {INFORMATION}. The called party number key data of the DECT &lt;&lt;KEYPAD&gt;&gt; in the DECT {CC-SETUP} and {CC-INFO} are mapped to an ISDN &lt;&lt;CALLED-PARTY-NUMBER&gt;&gt; in the ISDN {SETUP} and {INFORMATION}.</p>
<b>TP-KPSS-C-001</b>	<p>ETS 300 434-1 [6], subclause 5.2.1.1.1, 5.2.2.1, figure 10 ETS 300 705-2 [14] Profile specific ICS table C.10 item 4</p> <p>Initial state: The IWU is in state F00-U00.</p> <p>Check that the IUT manages rightly an outgoing call initiated by the PT with a DECT {CC-SETUP}. No &lt;&lt;CALLED-PARTY-NUMBER&gt;&gt; is included in the {CC-SETUP}, and dialling information are sent in &lt;&lt;KEYPAD&gt;&gt; of consecutive DECT {CC-INFO} in PT OVERLAP SENDING state. The IUT has chosen to send back a DECT {CC-SETUP-ACK} to the PT (case b). The supplementary service key data of the DECT &lt;&lt;KEYPAD&gt;&gt; in the DECT {CC-SETUP} and {CC-INFO} are collected mapped to an ISDN &lt;&lt;KEYPAD-FACILITY&gt;&gt; in the ISDN {SETUP}. The called party number key data of the DECT &lt;&lt;KEYPAD&gt;&gt; in the DECT {CC-SETUP} and {CC-INFO} are collected and mapped to an ISDN &lt;&lt;CALLED-PARTY-NUMBER&gt;&gt; in the ISDN {SETUP}.</p>
<b>TP-KPSS-C-002</b>	<p>ETS 300 434-1 [6], subclause 5.2.1.1.2, 5.2.2.1, figure 12 ETS 300 705-2 [14] Profile specific ICS table C.10 item 4</p> <p>Initial state: The IWU is in state F00-U00.</p> <p>Check that the IUT manages rightly an incoming call, initiated by the NT with an ISDN {SETUP} not containing enough dialling information to identify the destination, by collecting (in Overlap Receiving state) the dialling information in the {INFORMATION} received after the {SETUP}. The supplementary service key data received in the &lt;&lt;KEYPAD-FACILITY&gt;&gt; in the ISDN {SETUP} and in subsequent {INFORMATION} are collected until identification of the destination and sent in an &lt;&lt;IWU-to-IWU&gt;&gt; in the DECT {CC-SETUP}. The supplementary service key data received in the ISDN &lt;&lt;KEYPAD-FACILITY&gt;&gt; in subsequent {INFORMATION} after sending the DECT {CC-SETUP} are mapped in &lt;&lt;IWU-to-IWU&gt;&gt; in a DECT {CC-INFO}. All of &lt;&lt;DISPLAY&gt;&gt; received in ISDN call control messages are mapped to &lt;&lt;DISPLAY&gt;&gt; of the corresponding DECT messages.</p>

## 10.2.11 Test purposes for IWU messages mapping

<b>TP-MES-C-000</b>	<p>ETS 300 434-1 [6], subclause 5.2.4.1.1 ETS 300 705-2 [14] Profile specific ICS table C.17 item 1</p> <p>Initial state: The IWU is in state F02-U02</p> <p>Check that the IUT, on receipt of an ISDN {ALERTING}, sends a DECT {CC-ALERTING} to the PT and enters state F04-U04.</p>
<b>TP-MES-C-001</b>	<p>ETS 300 434-1 [6], subclause 5.2.4.1.2 ETS 300 705-2 [14] Profile specific ICS table C.17 item 2</p> <p>Initial state: The IWU is in state F02-U02</p> <p>Check that the IUT, on receipt of an ISDN {CALL-PROCEEDING}, sends a DECT {CC-CALL-PROCEEDING} to the PT and enters state F03-U03.</p>
<b>TP-MES-C-002</b>	<p>ETS 300 434-1 [6], subclause 5.2.4.1.6 ETS 300 705-2 [14] Profile specific ICS table C.17 item 6</p> <p>Initial state: The IWU is in state F02-U02 (the state can be also F01-U01, F03-U03, or F04-U04)</p> <p>Check that the IUT, on receipt of an ISDN {CONNECT}, sends a DECT {CC-CONNECT} to the PT and enters state F10-U10.</p>
<b>TP-MES-C-003</b>	<p>ETS 300 434-1 [6], subclause 5.2.4.1.7 ETS 300 705-2 [14] Profile specific ICS table C.17 item 7</p> <p>Initial state: The IWU is in state F07-U08</p> <p>Check that the IUT, on receipt of an ISDN {CONNECT-ACK}, sends a DECT {CC-CONNECT-ACK} to the PT and enters state F10-U10.</p>
<b>TP-MES-C-004</b>	<p>ETS 300 434-1 [6], subclause 5.2.4.1.8 ETS 300 705-2 [14] Profile specific ICS table C.17 item 8</p> <p>Initial state: The IWU is in state F10-U10</p> <p>Check that the IUT, on receipt of an ISDN {DISCONNECT}, sends a DECT {CC-RELEASE} to the PT and enters state F10-U12. The ISDN message type DISCONNECT is mapped into a DECT &lt;&lt;IWU-to-IWU&gt;&gt; of the {CC-RELEASE}.</p>
<b>TP-MES-C-005</b>	<p>ETS 300 434-1 [6], subclause 5.2.4.1.13 ETS 300 705-2 [14] Profile specific ICS table C.17 item 13</p> <p>Initial state: The IWU is in state F02-U02 (the state can be also F02-Uxx, F03-Uxx, F04-Uxx, F07-Uxx or F10-Uxx)</p> <p>Check that the IUT, on receipt of an ISDN {INFORMATION}, sends a DECT {CC-INFO} to the PT and remains in state F02-U02.</p>
<b>TP-MES-C-006</b>	<p>ETS 300 434-1 [6], subclause 5.2.4.1.14 ETS 300 705-2 [14] Profile specific ICS table C.17 item 14</p> <p>Initial state: The IWU is in state F00-U25</p> <p>Check that the IUT, on receipt of an ISDN {INFORMATION}, sends a DECT {CC-SETUP} message to the PT, an ISDN {CALL-PROCEEDING} to the NT and then enters state F06-U09. All mandatory dialling information and Information Elements received from previous messages (INFORMATION and SETUP) are mapped into the DECT {CC-SETUP}.</p>

<b>TP-MES-C-007</b>	<p>ETS 300 434-1 [6], subclause 5.2.4.1.16 ETS 300 705-2 [14] Profile specific ICS table C.17 item 16</p> <p>Initial state: The IWU is in state F01-U01.</p> <p>Check that the IUT, on receipt of an ISDN {PROGRESS}, sends a DECT {CC-INFO} to the PT. The ISDN &lt;&lt;progress indicator&gt;&gt;, is mapped into a DECT &lt;&lt;progress indicator&gt;&gt; of the {CC-INFO}.</p>
<b>TP-MES-C-008</b>	<p>ETS 300 434-1 [6], subclause 5.2.4.1.22 ETS 300 705-2 [14] Profile specific ICS table C.17 item 22</p> <p>Initial state: The IWU is in state F00-U00.</p> <p>Check that: the IUT, on receipt of an ISDN {SETUP} with &lt;&lt;sending complete&gt;&gt;, sends a DECT {CC-SETUP} to the PT, an ISDN {CALL-PROCEEDING} message to the NT and enters state F01-U01 (see Note 1 of TP-SPSS-C-000).</p>
<b>TP-MES-C-009</b>	<p>ETS 300 434-1 [6], subclause 5.2.4.1.23 ETS 300 705-2 [14] Profile specific ICS table C.17 item 23</p> <p>Initial state: The IWU is in state F02-U01.</p> <p>Check that: the IUT, on receipt of an ISDN {SETUP-ACK} with &lt;&lt;progress indicator&gt;&gt;, sends a DECT {CC-INFO} to the PT and enters state F02-U02.</p>
<b>TP-MES-C-010</b>	<p>ETS 300 434-1 [6], subclause 5.2.4.1.24 ETS 300 705-2 [14] Profile specific ICS table C.17 item 24</p> <p>Initial state: The IWU is in state F01-U01.</p> <p>Check that: the IUT, on receipt of an ISDN {SETUP-ACK}, sends a DECT {CC-SETUP-ACK} to the PT and enters state F02-U02.</p>
<b>TP-MES-C-011</b>	<p>ETS 300 434-1 [6], subclause 5.2.4.2.1 ETS 300 705-2 [14] Profile specific ICS table C.18 item 1</p> <p>Initial state: The IWU is in state F06-U09.</p> <p>Check that: the IUT, on receipt of an DECT {CC-ALERTING}, sends a ISDN {ALERTING} to the NT and enters state F07-U07.</p>
<b>TP-MES-C-012</b>	<p>ETS 300 434-1 [6], subclause 5.2.4.2.8 ETS 300 705-2 [14] Profile specific ICS table C.18 item 8</p> <p>Initial state: The IWU is in state F10-U10.</p> <p>Check that: the IUT, on receipt of an DECT {CC-RELEASE}, sends a ISDN {DISCONNECT} to the NT and enters state F10-U11.</p>
<b>TP-MES-C-013</b>	<p>ETS 300 434-1 [6], subclause 5.2.4.2.9 ETS 300 705-2 [14] Profile specific ICS table C.18 item 9</p> <p>Initial state: The IWU is in state F19-U12. (In state F10-U10, the IUT received an ISDN {DISCONNECT}, sent a DECT {CC-RELEASE} and entered into state F19-U12).</p> <p>Check that: the IUT, on receipt of an DECT {CC-RELEASE-COM}, sends a ISDN {RELEASE} to the NT and enters state F00-U19.</p>
<b>TP-MES-C-014</b>	<p>ETS 300 434-1 [6], subclause 5.2.4.2.10 ETS 300 705-2 [14] Profile specific ICS table C.18 item 10</p> <p>Initial state: The IWU is in state F10-U10.</p> <p>Check that: the IUT, on receipt of an DECT {CC-RELEASE-COM}, sends a ISDN {DISCONNECT} to the NT and enters state F00-U11.</p>

10.2.12 Test purposes for IWU management of call control protocol

<b>TP-CC-C-000</b>	cc_incoming_call_reject ETS 300 434-2 [7], subclause 5.2 ETS 300 705-2 [14] Profile specific ICS table C.25 item 2  Initial state: The IWU is in state F01-U01  Check that the IUT, on expiration of the CC-03 timer with no response received from PT to the {CC-SETUP} sent, sends a DECT {CC-RELEASE-COM} to the PT, an ISDN {RELEASE-COM} to the NT and then enters state F00-U00.
--------------------	--

10.2.13 Test purposes for segmented messages

<b>TP-SEG-C-000</b>	DLC more bit procedure ETS 300 434-1 [6], subclause 5.2.3.1 ETS 300 705-2 [14] Profile specific ICS table C.26 item 1  Initial state: The IWU is in state F10-U10 (ACTIVE state)  Check that the IUT, on receipt of {SEGMENT} from the NT, keeps and groups the all {SEGMENT} together, and then uses the DLC more bit procedure to transmit the whole message to the PT.
---------------------	---

10.3 Profile Abstract Test Method (ATM)

The figure 6 below shows the ATM used for testing the DECT/ISDN IWU part.

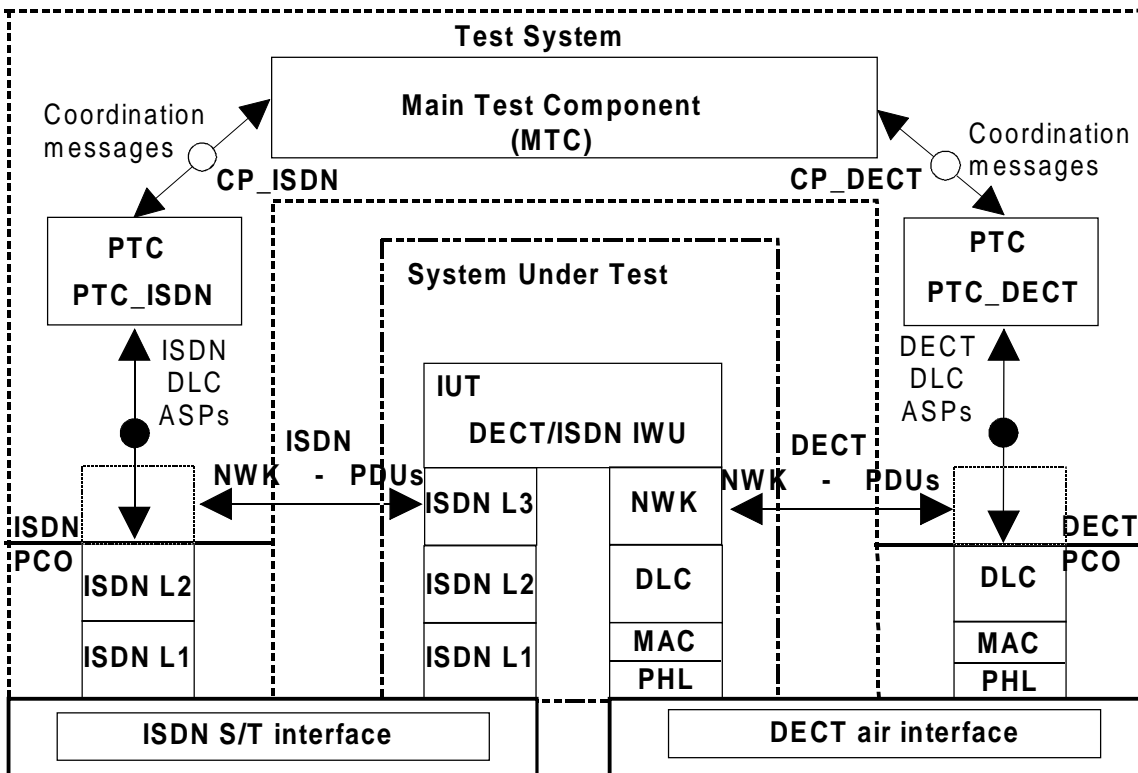

Figure 6: Multiparty testing for IAP



A multiparty testing concept is used, which consists of the following testing components:

- PCOs:** There are two PCOs in the test system. The first PCO, called PC\_IS, is on the SAP of the ISDN L3 layer. The second PCO, called PC\_DE, is on the SAP of the DECT NWK layer. All test events sent or received through these PCOs are specified as ASPs with embedded NPDUs.
- CP\_ISDN:** Co-ordination Point for ISDN interface is located between the MTC master test component and the PTC\_ISDN parallel test component in the test system. It is used for passing co-ordination messages between these two testing functions.
- CP\_DECT:** Co-ordination Point for DECT interface is located between the master test component (MTC) and the parallel test component PTC\_DECT in the test system. It is used for passing co-ordination messages between these two testing functions.
- PTC\_ISDN:** This Parallel Test Component is the upper-layer of the ISDN L3 layer in the test system. While the execution of each test case, it guides and verifies the ISDN part behaviour of the IUT by the related PCO.
- PTC\_DECT:** This Parallel Test Component is the upper-layer of the DECT NWK layer in the test system. While the execution of each test case, it guides and verifies the DECT part behaviour of the IUT by the related PCO.
- MTC:** The Main Test Component (MTC) is located in the test system. It leads the beginning, execution and completion of both PTCs. It manages the CP\_ISDN and CP\_DECT co-ordination points. It computes the final verdict of the test case.

#### 10.4 Profile Untestable test purposes

Due to the ATMs chosen for this ATS or other restrictions, the test purposes in table 5 have been identified as being in the untestable category, and therefore have not been derived into final test case:

**Table 5: Untestable TPs**

Test purpose	Reason
TC-SEG-CA-000	Due to the ATM chosen, it is not possible to observe the behaviour of the DLC layer.

#### 10.5 Profile ATS Conventions

This clause describes the conventions applied to define the ATS and gives the naming conventions chosen for the different elements of the ATS.

The ATS conventions are intended to give a better understanding of the ATS but they describe also the conventions made for the development of the ATS, thus for any later maintenance purposes or further development of the ATS the conventions described in this clause shall be considered.

The ATS conventions contain two parts, the naming conventions and the implementation conventions. The naming conventions describe the structure of the naming of all ATS elements. The implementation conventions describe the functional structure of the ATS.

### 10.5.1 Declarations part naming conventions

This subclause describes the naming conventions chosen for the elements of the ATS declarations part.

#### 10.5.1.1 Type and structured type definitions

The test suite type and test suite structured type identifiers describe the information elements, and are written in uppercase:

EXAMPLE:               PROTOCOL\_DISCRIMINATOR simple type.  
                          FILLSTRING structured type

#### 10.5.1.2 Operations definitions

The test suite operation identifiers are composed of string in lowercase letters starting by the uppercase string 'TSO\_'.

EXAMPLE:               TSO\_compute\_checksum.

#### 10.5.1.3 Parameter declarations

The test suite parameter identifiers are composed of string in lowercase letters starting by the uppercase string 'TSP\_'.

EXAMPLE:               TSP\_window\_size.

If the test suite parameter references an ICS item, the letter "C" is added to the standard prefix.

EXAMPLE:               TSPC\_pics\_item\_s23.

If the test suite parameter references an IXIT item, the letter "X" is added to the standard prefix.

EXAMPLE:               TSPX\_pixit\_item\_2.

If it is possible, complete names as defined in the specifications are used.

#### 10.5.1.4 Selection expression definitions

The naming conventions for the test case selection expression definitions use free text starting with an uppercase letter. The name of the expression shall explain clearly the selection rule. The test case selection expressions are logical combinations of the test suite parameters definitions.

#### 10.5.1.5 Constant declarations

The test suite constant identifiers are composed of string in lowercase letters starting by the uppercase string 'TSC\_'.

EXAMPLE:               TSC\_retry.

Complete names as defined in the specifications are used.

#### 10.5.1.6 Test suite variable declarations

The test suite variable identifiers are composed of string in lowercase letters starting by the uppercase string 'TSV\_'.

EXAMPLE:               TSV\_count.

**Exception:** If the test suite variable represents a system parameter or value, the name defined in the specifications is used.

EXAMPLE:               VR,VS.

#### 10.5.1.7 Test case variable declarations

The test case variable identifiers are composed of string in lowercase letters starting by the uppercase string 'TCV\_'.

EXAMPLE: TCV\_cr\_value.

#### 10.5.1.8 PCO declarations

The point of control and observation identifiers are composed of two or four capital letters, beginning with 'P'.

EXAMPLE: PISDN represents a PCO on ISDN interface in the test equipment.  
PDECT represents a PCO on DECT interface in the test equipment.

#### 10.5.1.9 Timer declarations

Two kinds of timers can be distinguished:

1) standardised:

Those defined in the standard, e.g. DL\_04, use exactly the same name as in the standard, beginning with a capital 'T'.

As there is a tolerance margin accepted for these timers, three values are needed:

- the maximum value allowed, which will use the suffix '\_max';
- the minimum value allowed, which will use the suffix '\_min';
- the value actually implemented, with no suffix.

EXAMPLE: TDL\_04\_max, TDL\_04\_min, and TDL\_04.

2) not standardised:

Those not defined in the standard, i.e. for execution use, e. g. a timer waiting for a response. These timers begin with the prefix 'T\_', followed by a string in lowercase letters.

EXAMPLE: T\_resp represents a timer for controlling the response time of the IUT.

#### 10.5.1.10 ASP type definitions

The identifier of an ASP uses exactly the nearest name as the name defined in the specifications. It is written in uppercases, finishing by an underscore character ('\_'), and three capital letters indicating whether it is a request, an indication, a response or a confirmation primitive.

EXAMPLE: DL\_RELEASE\_REQ for an ASP containing a layer 3 release request passed to layer 2.  
MAC\_DATA\_REQ for an ASP containing a layer 2b PDU passed to layer 2a.

#### 10.5.1.11 PDU type definitions

The identifier of a PDU is given in a string in uppercase letters, which represents the layer message.

EXAMPLE: RR for the Receive Ready layer 2 message.  
DISCONNECT for the DISCONNECT layer 3 message.

Where the message is a composite word, an underscore character ('\_') appears in the string.

EXAMPLE: RELEASE\_COMPLETE is the RELEASE COMPLETE layer 3 message.

### 10.5.1.12 Alias definitions

These are used to make the sending and receiving of PDUs within ASPs more understandable when writing the dynamic part of the test suite. This is done by giving the ASP an alias. The alias name indicates the PDU carried by the ASP and whether it is sent or received by the tester.

No aliases are used in the test suite.

### 10.5.2 Constraints part naming conventions

This subclause describes the naming conventions chosen for the elements of the ATS constraints part.

Constraint identifiers commence with uppercase. The remaining part of the Id name is written in lowercase.

Identifier names of elements concerning the same subject have equivalent names in the declaration and the constraint part:

- Declaration Part: CC\_SETUP
- Constraint Part: Cc\_setup

The name of the modified constraint describes the particularity of the modified constraint:

e.g. Cc\_setup\_mand\_only (modified Cc\_setup with only the mandatory Information Elements).

If formal parameter lists are used, the variable names are written in lowercase. The variable name is the same as the name of the element it is representing.

### 10.5.3 Dynamic part naming conventions

This Subclause describes the naming conventions chosen for the elements of the ATS dynamic part.

#### 10.5.3.1 Test Case identifier

The identifier of a test case is built according to table 6:

**Table 6: TC naming convention**

Identifier:	<b>TC-&lt;fm&gt;-x-&lt;nnn&gt;</b>		
<fm>	= functional module	CCCE	CC - call establishment
		CCCI	CC - call information
		CCCR	CC - call release
		SPSS	specific SS procedures
		FPIS	CISS functional protocol
		FPRS	CRSS functional protocol
		KPSS	CRSS keypad protocol
		MES	messages mapping
		CC	IWU specific CC procedures
		SEG	segmented messages
x	= Type of testing	CA	CA, Capability tests
		BV	BV, Valid Behaviour tests
		BO	BO, Inopportune Behaviour tests
		BI	BI, Invalid Behaviour tests
<nnn>	= sequential number	(000-999)	test case Number

### 10.5.3.2 Test step identifier

The test step identifier is built with a string of lowercase letters led by a string of capital letter and joined by an underscore character. The first string indicates the main function of the test step; e.g. PR for preamble, PO for postamble, LTS for local tree name and STP for general step. The second string indicates the meaning of the step.

EXAMPLES:           PR\_name  
                      PO\_name  
                      LTS\_name  
                      STP\_name

### 10.5.3.3 Default identifier

The Default identifiers begin with the prefix 'DF\_', followed by a string in lowercase letters.

### 10.5.3.4 General aspects

All verdict assignments are labelled. To allow an exact identification in which table the verdict was assigned, the following name convention is applied:

TB	test Body
DF	Default
EH	Error handling test steps
PO	POstamble
PR	PReamble
TS	test step

### 10.5.3.5 ATS abbreviations

These abbreviations are used to shorten identifier names:

addr	address
ack	acknowledgement
cau	cause
cc	call control
chn	channel
est	establish
ind	indication
mety	message type
mod	modified
par	parameter
pd	protocol discriminator
req	request
rsp	response

### 10.5.4 Declaration part implementation conventions

The comment line of single element TTCN tables (e.g. test suite constants) is used to give a reference where the format and content of the element are described in the relevant protocol specifications. Any particularity of the element format or content is described in the comment line.

The comment line in the header of multi-element TTCN tables (e.g. ASPs) is used to reference to the protocol specification.

The detailed comments are used to describe any particularity of the table.

In the ASP and PDU declarations, the comments column is used to identify if an element is mandatory or optional:

- M: mandatory.

In the ASP and PDU declarations the comments column is further used to give information about the element value, in particular if the element contains a fixed spare value.

### 10.5.5 Constraint part implementation conventions

The ASPs and PDUs are defined in a way that all relevant elements are parametrized. That improves the transparency of the constraints in the dynamic part, as all values which are relevant for the test are always present.

Generally no modified constraints are used, this allows an easier reuse and adaptation of constraints if they are reused in other DECT profile test specifications.

The Comment line of a constraint contains always the reference to the used specifications.

The detailed comments sector is used to describe any particularity of the table.

### 10.5.6 Dynamic part implementation conventions

Some TCs need a particular initialisation of the IUT environment conditions to run the actual test, e.g. for testing re-provisioning procedures. Such message sequence can be quite complicated and long. In cases where a local test step (LTS) facilitates the TC structure, the preamble and the condition setting are described in a LTS called LTS\_pre\_step. All LTS\_pre\_steps are described in the detailed comment part of the TTCN table.

Some TCs need after the actual test a particular re-initialisation of the IUT, e.g. after re-provisioning. Such message sequence can be quite complicated and long. In cases where a local test step (LTS) facilitates the TC structure, the postamble and the re-initialisation are described in a LTS called LTS\_post\_step. All LTS\_post\_steps are described in the detailed comment part of the TTCN table.

All events which are defined as a conformance requirement by the TP, cause a preliminary verdict PASS if the requirement is met.

All invalid events are handled in the default tree. Only FAIL verdicts can be assigned in the default tree.

The preamble, the test body and the postamble have different defaults, which allows a specific verdict handling, e.g. only INCONC verdicts are assigned in the preamble.

Test steps do not contain a default. That allows to apply them with no restrictions regarding the error handling.

All verdict assignments are labelled. According to ISO 9646-3 [41], Annex E.2, labels should be written to the conformance log. This allows to identify where the test failed. To allow an exact identification in which table the verdict was assigned, the naming convention as described in subclause 10.5.1.3.4 applied.

The labels of the same type are numbered sequentially if they are in the same TC, test step or default.

TPs which are listed in the untestable TP list, or which reference to an other TP, e.g. BV TPs which were already defined as CA TPs, are not considered in the ATS, thus these TC identifiers are missing in the ATS and the numbering of the TCs is not always continues.

### 10.5.7 Documentation implementation conventions

The comment line of the TC or test step header contains a reference to the relevant protocol specification.

The comment column of the dynamic behaviour part is used to number the test events which are relevant for the particular test or test operation.

Based on the numbering in the comment column all for the TC relevant events are described in the detailed comments part of each TTCN table.

Test procedures which cover a conformance requirement and lead to a preliminary or final verdict assignment are described as follows in the detailed comments part:

- expected event: a specific receive event is expected.
- expected behaviour: no event or a timer expiry is expected.
- expected status: the IUT is expected to be in a particular status.

### 10.6 Test case and test purpose mapping

There is a one-to-one mapping between the test case identifiers and the test purpose identifiers. The correspondence rule is given by the following examples:

<b>Test purpose identifier</b>	<b>Test case identifier</b>
TP-CCCE-C-000	TC-CCCE-CA-000
TP-CCCE-V-000	TC-CCCE-BV-000
TP-CCCE-O-000	TC-CCCE-BO-000
TP-CCCE-I-000	TC-CCCE-BI-000
TP-SEG-C-000	TC-SEG-CA-000
TP-MES-V-001	TC-MES-BV-001
TP-CC-O-002	TC-CC-BO-002
TP-CC-I-003	TC-CC-BI-003

**Annex A (normative): Profile Implementation eXtra Information for Testing (IXIT) proforma for DECT/ISDN IAP profile - Fixed radio Termination (FT)**

Notwithstanding the provisions of the copyright clause related to the text of the present ETS (see the front page), ETSI grants users of this ETS to freely reproduce the Profile IXIT Proforma in this annex so that it can be used for its intended purposes and may further publish the completed Profile IXIT.

The PIXIT Proforma is based on ISO/IEC 9646-6 [27]. Any additional information needed can be found in this international standard document.

**A.1 Identification summary**

**Table A.1: Identification summary**

PIXIT Number:	
Test Laboratory Name:	
Date of Issue:	
Issued to:	

**A.2 ATS summary**

**Table A.2: ATS summary**

Protocol Specification:	
Protocol to be tested:	
ATS Specification:	
Abstract Test Method:	

**A.3 Test laboratory**

**Table A.3: Test laboratory**

Test Laboratory Identification:	
Test Laboratory Manager:	
Means of Testing:	
SAP Address:	



## A.4 Client identification

Table A.4: Client identification

Client Identification:	
Client Test manager:	
Test Facilities required:	

## A.5 SUT

Table A.5: SUT

Name:	
Version:	
SCS Number:	
Machine configuration:	
Operating System Identification:	
IUT Identification:	
PICS Reference for IUT:	
Limitations of the SUT:	
Environmental Conditions:	

## A.6 Profile information

Table A.6: General parameters

Item	Name and Type	Explanation and answer
1	TSPX_decimal_ac_value Type : OCT_4 (OCTETSTRING[4])	Value of AC to be used. The AC will be entered as maximal 8 decimal digits. The AC to bitstring mapping will be done with operator TSO_convert_ac_to_bitstring. <b>Value :</b>
2	TSPX_dlei_value Type : DATA_LINK_ENDPOINT_IDENTIFIER (INTEGER)	Value of data link endpoint identifier to be used in the test system (local test system matter). <b>Value :</b>
3	TSPX_dlci_value Type : DATA_LINK_ENDPOINT_IDENTIFIER (INTEGER)	Value of ISDN DLCI to be used in the test system (local test system matter). <b>Value :</b>
4	TSPX_location_area_level Type : BIT_6 (BITSTRING[6])	The location area level that is going to be used. <b>Value :</b>
5	TSPX_decimal_upi_value Type : OCT_4 (OCTETSTRING[4])	Value of UPI to be used. The UPI will be entered as maximal 8 decimal digits. The UPI to bitstring mapping will be done with operator TSO_convert_upi_to_bitstring. <b>Value :</b>

Table A.7: Portable part parameters

Item	Name and Type	Explanation and answer
1	TSPX_ipei_value Type : PORT_ID_VALUE_TYPE (BITSTRING[8..104])	Value of IPEI (IPUI-N) to be expected from the IUT (before subscription). <b>Value :</b>
2	TSPX_ipui_value Type : PORT_ID_VALUE_TYPE (BITSTRING[8..104])	Value of portable_id to be used in case of a IPUI (after subscription). <b>Value :</b>
3	TSPX_tpui_value Type : PORT_ID_VALUE_TYPE (BITSTRING[8..104])	Value of tpui to be used, when assigning a tpui to the IUT. <b>Value :</b>

Table A.8: Fixed part parameters

Item	Name and Type	Explanation and answer
1	TSPX_ari_value Type : FIXED_ID_VALUE_TYPE (BITSTRING[8..72])	Value of fixed_id to be used in case of ARI. <b>Value :</b>
2	TSPX_ari_rpn_value Type : FIXED_ID_VALUE_TYPE (BITSTRING[8..72])	Value of fixed_id to be used in case of ARI + RPN. <b>Value :</b>
3	TSPX_park_value Type : FIXED_ID_VALUE_TYPE (BITSTRING[8..72])	Value of fixed_id to be used in case of PARK. <b>Value :</b>
4	TSPX_park_length_indicator Type : PARK_LENGTH_TYPE (INTEGER(0..36))	This parameter indicates the number of significant bits in PARK. <b>Value :</b>

Table A.9: DECT information elements field values

Item	Name and Type	Explanation and answer
1	TSPX_called_party_number Type : OCT_1_14 (OCTETSTRING[1..14])	Content of the called party address field of the DECT <<Called party number>> information element. It is used for testing value on received events or for filling field of sent events. <b>Value :</b>
2	TSPX_nr_of_digits_in_cpn Type : CPN_LENGTH_TYPE (INTEGER(1..14))	This parameter indicates the number of digits present in the Called party address. <b>Value :</b>

Table A.10: ISDN information elements field values

Item	Name and Type	Explanation and answer
1	TSPX_i_called_party_number Type : OCT_1_14 (OCTETSTRING[1..14])	Called party address field of the ISDN <<Called party number>> information element. It is used for testing value on received events or for filling field of sent events. <b>Value :</b>
2	TSPX_i_calling_party_number Type : OCT_1_14 (OCTETSTRING[1..14])	Calling party address field of the ISDN <<Calling party number>> information element. It is used for testing value on received events or for filling field of sent events. <b>Value :</b>
3	TSPX_i_connected_party_number Type : OCT_1_14 (OCTETSTRING[1..14])	Connected party address field of the ISDN <<Connected party number>> i.e. Used for testing value on received events or for filling field of sent events. <b>Value :</b>
4	TSPX_i_called_party_subaddress Type : OCT_1_20 (OCTETSTRING[1..20])	Subaddress information field of the ISDN <<Called party subaddress>> i.e. Used for testing value on received events or for filling field of sent events. <b>Value :</b>
5	TSPX_bearer_cap1 Type : OCT_0_10 (OCTETSTRING[0..10])	Bearer information for ISDN <<Bearer capability>> i.e. Used for filling sent events. <b>Value :</b>
6	TSPX_bearer_cap2 Type : OCT_0_10 (OCTETSTRING[0..10])	Bearer information for ISDN <<Bearer capability>> i.e. Used for filling sent events and shall be different from TSPX_bearer_cap1. <b>Value :</b>
7	TSPX_hlc1 Type : OCT_2 (OCTETSTRING[2])	High layer capability information for ISDN <<High layer capability>> i.e. Used for filling sent events. <b>Value :</b>
8	TSPX_hlc2 Type : OCT_2 (OCTETSTRING[2])	High layer capability information for ISDN <<High layer capability>> i.e. Used for filling sent events and shall be different from TSPX_hlc1. <b>Value :</b>
9	TSPX_keypad_part1 Type : DECT_1_255 (OCTETSTRING[1..255])	Set of key data for supplementary service and called party number. Used with part 2 it shall be possible to provide a sub address field for <<Called party number>> and information field for <<Facility>>. <b>Value :</b>
10	TSPX_keypad_part2 Type : DECT_1_255 (OCTETSTRING[1..255])	Set of key data for supplementary service and called party number. Used with part 1 it shall be possible to provide a sub address field for <<Called party number>> and information field for <<Facility>>. <b>Value :</b>

**Annex B (normative): Profile Conformance Test Report (Profile CTR) proforma for DECT/ISDN IAP profile - Fixed radio Termination (FT)**

Notwithstanding the provisions of the copyright clause related to the text of the present ETS (see the front page), ETSI grants users of this ETS to freely reproduce the Profile CTR proforma in this annex so that it can be used for its intended purposes and may further publish the completed Profile CTR.

The Profile CTR proforma is based on ISO/IEC 9646-5 [26] Any additional information needed can be found in this document.

**B.1 Identification summary**

**B.1.1 Protocol conformance test report**

**Table B.1: Protocol conformance test report**

PCTR Number:	
PCTR Date:	
Test Laboratory Identification:	
Accreditation Status	
Accreditation Reference	
Technical Authority	
Job Title	
Signature	
Test Laboratory Manager:	
Signature:	

**B.1.2 IUT identification**

**Table B.2: IUT identification**

Name:	
Version:	
Protocol specification:	
Profile Specific ICS	

**B.1.3 Testing environment**

**Table B.3: Testing environment**

Profile specific IXIT:	
ATS Specification:	
Abstract Test Method:	
Means of Testing identification:	
Period of testing:	
Conformance Log reference(s):	
Retention Date for Log reference(s):	

**B.1.4 Limits and reservation**

The test results presented in this test report apply only to the particular IUT declared in subclause B.1.2, as presented for test in the period declared in subclauses B.1.3, and configured as declared in the relevant IXIT attached to this Profile CTR.

NOTE: Additional information relevant to the technical contents or further use of the test report, or the rights and obligations of the test laboratory and the client, may be given here. Such information may include restriction on the publication of the report.

.....  
.....  
.....  
.....  
.....

**B.1.5 Comments**

NOTE: Additional comments may be given by either the client or the test laboratory on any of the contents of the Profile CTR, for example, to note disagreement between the two parties.

.....  
.....  
.....  
.....  
.....

**B.2 IUT conformance status**

This IUT has or has not been shown by conformance assessment to be non conforming to the specified profile specification.

**Strike the appropriate words in this sentence. If the PICS for this IUT is consistent with the static conformance requirements (as specified in clause 3 in this report) and there are no "FAIL" verdicts to be recorded (in clause 6) strike the words "has or". otherwise strike the words "or has not".**

NOTE: For further details see ISO 9646-5 [26].

### B.3 Static conformance summary

The Profile specific ICS for this IUT is or is not consistent with the static conformance requirements in the specified profile.

**Strike the appropriate words in this sentence.**

NOTE: For further details see ISO 9646-5 [26].

### B.4 Dynamic conformance summary

The test campaign did or did not reveal errors in the IUT.

**Strike the appropriate words in this sentence. If there are no "FAIL" verdicts to be recorded (in clause 6 of this report) strike the words "did or". otherwise strike the words "or did not".**

Summary of the results of groups of test:

.....  
.....  
.....  
.....  
.....  
.....

NOTE: For further details see ISO 9646-5 [26].

### B.5 Static conformance review report

**If section 3 indicates non-conformance, this section itemises the mismatches between the PICS and the static conformance requirements of the referenced base and profile specification.**

.....  
.....  
.....  
.....  
.....  
.....  
.....  
.....  
.....  
.....

**B.6 Test campaign report**

**Table B.4: Test campaign report**

ATS Reference	Selected ?	Run ?	Verdict	Observations (Reference to any observations made in clause B.7)
TC-CCCE-CA-000	Yes/No	Yes/No		
TC-CCCE-CA-001	Yes/No	Yes/No		
TC-CCCE-CA-002	Yes/No	Yes/No		
TC-CCCE-CA-003	Yes/No	Yes/No		
TC-CCCE-CA-004	Yes/No	Yes/No		
TC-CCCE-CA-005	Yes/No	Yes/No		
TC-CCCE-CA-006	Yes/No	Yes/No		
TC-CCCE-CA-007	Yes/No	Yes/No		
TC-CCCI-CA-000	Yes/No	Yes/No		
TC-CCCR-CA-000	Yes/No	Yes/No		
TC-CCCR-CA-001	Yes/No	Yes/No		
TC-CCCR-CA-002	Yes/No	Yes/No		
TC-CCCR-CA-003	Yes/No	Yes/No		
TC-CCCR-CA-004	Yes/No	Yes/No		
TC-SPSS-CA-000	Yes/No	Yes/No		
TC-SPSS-CA-001	Yes/No	Yes/No		
TC-SPSS-CA-002	Yes/No	Yes/No		
TC-SPSS-CA-003	Yes/No	Yes/No		
TC-SPSS-CA-004	Yes/No	Yes/No		
TC-SPSS-CA-005	Yes/No	Yes/No		
TC-SPSS-CA-006	Yes/No	Yes/No		
TC-SPSS-CA-007	Yes/No	Yes/No		
TC-SPSS-CA-008	Yes/No	Yes/No		
TC-SPSS-CA-009	Yes/No	Yes/No		
TC-SPSS-CA-010	Yes/No	Yes/No		
TC-SPSS-CA-011	Yes/No	Yes/No		
TC-SPSS-CA-012	Yes/No	Yes/No		
TC-SPSS-CA-013	Yes/No	Yes/No		
TC-FPIS-CA-000	Yes/No	Yes/No		
TC-FPIS-CA-001	Yes/No	Yes/No		
TC-FPIS-CA-002	Yes/No	Yes/No		
TC-FPIS-CA-003	Yes/No	Yes/No		
TC-FPIS-CA-004	Yes/No	Yes/No		
TC-FPIS-CA-005	Yes/No	Yes/No		
TC-FPIS-CA-006	Yes/No	Yes/No		
TC-FPRS-CA-000	Yes/No	Yes/No		
TC-FPRS-CA-001	Yes/No	Yes/No		
TC-FPRS-CA-002	Yes/No	Yes/No		
TC-FPRS-CA-003	Yes/No	Yes/No		
TC-FPRS-CA-004	Yes/No	Yes/No		
TC-FPRS-CA-005	Yes/No	Yes/No		
TC-FPRS-CA-006	Yes/No	Yes/No		
TC-FPRS-CA-007	Yes/No	Yes/No		
TC-FPRS-CA-008	Yes/No	Yes/No		
TC-FPRS-CA-009	Yes/No	Yes/No		
TC-FPRS-CA-010	Yes/No	Yes/No		
TC-FPRS-CA-011	Yes/No	Yes/No		

(continued)





**Annex C (normative): System Conformance Test Report proforma (SCTR) for DECT/ISDN IAP profile - Fixed radio Termination (FT)**

Notwithstanding the provisions of the copyright clause related to the text of this ETS, ETSI grants that users of this ETS may freely reproduce the SCTR proforma in this annex so that it can be used for its intended purposes and may further publish the completed SCTR.

**C.1 Identification summary**

**C.1.1 System conformance test report**

**Table C.1: System conformance test report**

SCTR Number	
SCTR Date	
Test Laboratory Manager	
Signature	

**C.1.2 Test laboratory**

**Table C.2: Test laboratory**

Identification	
Address	
Postal code/city	
Country	
Telephone	
Telefax	
Telex	
Teletex	
E-Mail	

### C.1.3 Client identification

Table C.3: Client identification

Identification	
Address	
Postal code/city	
Country	
Telephone	
Telefax	
Telex	
Teletex	
E-Mail	

### C.1.4 System Under Test (SUT)

Table C.4: System Under Test (SUT)

Name	
Version	
Supplier	
Dates of testing	
Date of receipt of SUT	
Location of SUT for Testing	
SCS Identifier	

### C.1.5 Profile identification

Table C.5: Profile identification

Profile Identification	
Profile Version	
Profile ICS	ETSI ETS 300 705-2 [14] Annexe C
Profile Specific IXIT	Annex A of this specification (ETSI DE/RES-03018-3)
PTS-Summary	Part 1 of this specification (ETSI DE/RES-03018-1)
PSTS	this specification (ETSI DE/RES-03018-3)

### C.1.6 Nature of conformance testing

The purpose of Conformance Testing is to increase the probability that different implementations can interwork in different environments. However, the complexity of OSI protocols makes exhaustive testing impractical on both technical and economic grounds. Furthermore, there is no guarantee that an SUT which has passed all the relevant test cases conforms to a specification. Neither is there any guarantee that such an SUT will interwork with other real open systems. Rather, the passing of the test cases gives confidence that the SUT has the stated capabilities and that its behaviour conforms consistently in representative instances of communication.

### C.1.7 Limits and reservations

The test results presented in this test report apply only to the particular SUT and component IUTs declared in subclause C.1.4 and C.1.8, for the functionality described in the referenced SCS and in the ICS referenced in each PCTR, as presented for test in the period declared in section C.1.4 and configured as declared in the relevant IXIT referenced in each PCTR. This SCTR may not be reproduced except in full together with its SCS.

**Table C.6: Limits and reservations**

--

NOTE: Additional information relevant to the technical contents or further use of the test report, or to the rights and obligations of the test laboratory and the client, may be given here. Such information may include restrictions on the publication of the report.

### C.1.8 Record of agreement

A definition of what parts of the SUT were considered to be the IUT during testing, and of the abstract test method and abstract test suite that were used:

**Table C.7: Record of agreement**

IUT Definition Reference	Protocol	ATM	ATS
	DECT NWK layer		ETS 300 497-9 [20]
	DECT DLC layer		ETS 300 497-5 [18]
	DECT MAC layer		ETS 300 497-3 [16]
	DECT PH layer		ETS 300 176 [8]
	ISDN L3 primary access		TBR 4 [38] Annexe D
	ISDN L2 primary access		TBR 4 [38] Annexe C
	ISDN L1 primary access		TBR 4 [38] Annexe B
	ISDN L3 basic access		TBR 3 [37] Annexe D
	ISDN L2 basic access		TBR 3 [37] Annexe C
	ISDN L1 basic access		TBR 3 [37] Annexe B
	GAP Profile		TBR 22 [39]
	IAP Profile		main part of his specification (ETSI DE/RES-03018-3)

C.1.9 Comments

Table C.8: Comments

Additional comments reference in annex:	
---	--

NOTE: Additional comments may be given by either the client or test laboratory on any of the contents of the SCTR, for example, to note disagreement between the two parties.

C.2 System report summary for DECT/ISDN IAP FT

C.2.1 Profile testing summary for DECT NWK layer protocol

Table C.9: DECT NWK layer protocol

Accreditation status	
Accreditation reference	
Implementation identifier	
IUT definition reference	
Protocol specification	ETS 300 175-5 [4]
ICS	ETS 300 476-4 [9]
IXIT	ETS 300 497-9 [20]
PCTR Number	
PCTR Date	
ATS specification	ETS 300 497-9 [20]
ATM	Remote
Means of Testing identifier	
Conformance Status: Static conformance errors?	Yes / No
Conformance Status: Dynamic conformance errors?	Yes / No
Number of Test cases run:	
Number of Test cases Passed:	
Number of Test cases Inconclusive:	
Number of Test cases Failed:	
Observations:	

C.2.2 Profile testing summary for DECT DLC layer protocol

Table C.10: DECT DLC layer protocol

Accreditation status	
Accreditation reference	
Implementation identifier	
IUT definition reference	
Protocol specification	ETS 300 175-4 [3]
ICS	ETS 300 476-5 [10]
IXIT	ETS 300 497-5 [18]
PCTR Number	
PCTR Date	
ATS specification	ETS 300 497-5 [18]
ATM	ETS 300 497-5 [18]
Means of Testing identifier	
Conformance Status: Static conformance errors?	Yes / No
Conformance Status: Dynamic conformance errors?	Yes / No
Number of Test cases run:	
Number of Test cases Passed:	
Number of Test cases Inconclusive:	
Number of Test cases Failed:	
Observations:	

## C.2.3 Profile testing summary for DECT MAC layer protocol

Table C.11: DECT MAC layer protocol

Accreditation status	
Accreditation reference	
Implementation identifier	
IUT definition reference	
Protocol specification	ETS 300 175-3 [2]
ICS	ETS 300 476-6 [11]
IXIT	ETS 300 497-3 [16]
PCTR Number	
PCTR Date	
ATS specification	ETS 300 497-3 [16]
ATM	ETS 300 497-3 [16]
Means of Testing identifier	
Conformance Status: Static conformance errors?	Yes / No
Conformance Status: Dynamic conformance errors?	Yes / No
Number of Test cases run:	
Number of Test cases Passed:	
Number of Test cases Inconclusive:	
Number of Test cases Failed:	
Observations:	

**C.2.4 Profile testing summary for DECT PH layer protocol**

**Table C.12: DECT PH layer protocol**

Accreditation status	
Accreditation reference	
Implementation identifier	
IUT definition reference	
Protocol specification	ETS 300 175-2 [1]
ICS	ETS 300 476-7 [12]
IXIT	-
PCTR Number	
PCTR Date	
ATS specification	ETS 300 176 [8]
ATM	-
Means of Testing identifier	
Conformance Status: Static conformance errors?	Yes / No
Conformance Status: Dynamic conformance errors?	Yes / No
Number of Test cases run:	
Number of Test cases Passed:	
Number of Test cases Inconclusive:	
Number of Test cases Failed:	
Observations:	

## C.2.5 Profile testing summary for ISDN L3, L2, L1 primary access protocol

Table C.13: ISDN L3, L2, L1 primary access protocol

Accreditation status	
Accreditation reference	
Implementation identifier	
IUT definition reference	
Protocol specification	L3 - ETS 300 403-1 [29] L2 - ETS 300 402-2 [31] L1 - ETS 300 011 [33]
ICS	L3 - ETS 300 403-3 [30] L2 - ETS 300 402-4 [32] L1 - ETS 300 011/A2 [34]
IXIT	TBR 4 [38]
PCTR Number	
PCTR Date	
ATS specification	TBR 4 [38]
ATM	TBR 4 [38]
Means of Testing identifier	
Conformance Status: Static conformance errors?	Yes / No
Conformance Status: Dynamic conformance errors?	Yes / No
Number of Test cases run:	
Number of Test cases Passed:	
Number of Test cases Inconclusive:	
Number of Test cases Failed:	
Observations:	



**C.2.6 Profile testing summary for ISDN L3, L2, L1 basic access protocol**

**Table C.14: ISDN L3, L2, L1 basic access protocol**

Accreditation status	
Accreditation reference	
Implementation identifier	
IUT definition reference	
Protocol specification	L3 - ETS 300 403-1 [29] L2 - ETS 300 402-2 [31] L1 - ETS 300 012 [35]
ICS	L3 - ETS 300 403-3 [30] L2 - ETS 300 402-4 [32] L1 - ETS 300 012/A2 [36]
IXIT	TBR 3 [37]
PCTR Number	
PCTR Date	
ATS specification	TBR 3 [37]
ATM	TBR 3 [37]
Means of Testing identifier	
Conformance Status: Static conformance errors?	Yes / No
Conformance Status: Dynamic conformance errors?	Yes / No
Number of Test cases run:	
Number of Test cases Passed:	
Number of Test cases Inconclusive:	
Number of Test cases Failed:	
Observations:	

## C.2.7 Profile testing summary for DECT GAP profile

Table C.15: DECT GAP profile

Accreditation status	
Accreditation reference	
Implementation identifier	
IUT definition reference	
Protocol specification	ETS 300 444 [5]
ICS	ETS 300 474-2 [13]
IXIT	ETS 300 494-3 [21]
PCTR Number	
PCTR Date	
ATS specification	TBR 22 [39]
ATM	TBR 22 [39]
Means of Testing identifier	
Conformance Status: Static conformance errors?	Yes / No
Conformance Status: Dynamic conformance errors?	Yes / No
Number of Test cases run:	
Number of Test cases Passed:	
Number of Test cases Inconclusive:	
Number of Test cases Failed:	
Observations:	

**C.2.8 Profile testing summary for DECT/ISDN IAP profile**

**Table C.16: DECT/ISDN IAP profile**

Accreditation status	
Accreditation reference	
Implementation identifier	
IUT definition reference	
Protocol specification	ETS 300 434-1 [6] and ETS 300 434-2 [7]
ICS	ETSI ETS 300 705-2 [14] Annexe C
IXIT	This specification (ETSI DE/RES-03018-3)
PCTR Number	
PCTR Date	
ATS specification	This specification (ETSI DE/RES-03018-3)
ATM	This specification (ETSI DE/RES-03018-3)
Means of Testing identifier	
Conformance Status: Static conformance errors?	Yes / No
Conformance Status: Dynamic conformance errors?	Yes / No
Number of Test cases run:	
Number of Test cases Passed:	
Number of Test cases Inconclusive:	
Number of Test cases Failed:	
Observations:	

## Annex D (normative): Profile eXtra Requirement List (XRL) proforma for DECT/ISDN IAP profile - Fixed radio Termination (FT)

Notwithstanding the provisions of the copyright clause related to the text of this ETS, ETSI grants that users of this ETS may freely reproduce the XRL proforma in this annexe so that it can be used for its intended purposes and may further publish the completed XRL.

Depending of the SUT, ISDN primary and basic access protocols may or may not be implemented. The tables, hereafter are additional tables for the referred PIXIT. The tables define Boolean items use for additional test case selection expression.

### D.1 ISDN primary access protocols

Additional table for the PIXIT of ISDN primary access protocols (ETS 300 052-4 [32]).

**Table D.1: ISDN primary access protocols implementation status**

Item Name	Item Type	Question	Value
PISDN_MSN_implemented	Boolean	Is the ISDN primary access protocols implemented?	TRUE [ ] FALSE [ ]

### D.2 ISDN basic access protocols

Additional table for the PIXIT of ISDN basic access protocols (ETS 300 058-4 [36]).

**Table D.2: ISDN basic access protocols implementation status**

Item Name	Item Type	Question	Value
BISDN_MSN_implemented	Boolean	Is the ISDN basic access protocols implemented?	TRUE [ ] FALSE [ ]

## Annex E (normative): Modifications of the PCTR proforma related to DECT/ISDN IAP profile - Fixed radio Termination (FT)

### E.1 Modifications of DECT NWK layer PCTR proforma

For the requirements of the DECT/ISDN IAP the following modifications shall be applied to the PCTR proforma furnished in ETS 300 497-9 [20], annex C.

Table E.1 is the replacement table for table C.2 of ETS 300 497-9 [20], subclause C.1.2.

**Table E.1**

Name:	
Version:	
Protocol specification:	ETS 300 175-5 [4]
PICS:	ETS 300 476-4 [9]
Profile RL:	ETSI ETS 300 705-2 [14]
Previous PCTR if any:	

Table E.2 is the replacement table for table C.3 of ETS 300 497-9 [20], subclause C.1.3.

**Table E.2**

PIXIT:	ETS 300 497-9 [20]
Profile XRL:	Annex D of this specification (ETSI DE/RES-03018-3)
ATS Specification:	ETS 300 497-9 [20]
Abstract Test Method:	Remote test method, Embedded variant with no UT
Means of Testing identification:	
Date of testing:	
Conformance Log reference(s):	
Retention Date for Log reference(s):	

Table E.3 is the replacement table for table C.4 of ETS 300 497-9 [20], clause C.6.

The new column "St" indicates the origin of the test case. The value "O" indicates an original unmodified test case. The value "A" indicates an additional test case. The value "R" indicates a replacement test case. The value "M" indicates a test case in which one or more components, such as constraint, behaviour line, etc., are modified. The values "A, R, M" are due to the requirements of the DECT/ISDN IAP profile.

For the values "O" and "M", the corresponding test purposes can be found in the relevant part of the respective standard. For the other values, the corresponding test purposes can be found in this PSTS.

Table E.3

ATS Reference	St.	Selected ?	Run ?	Verdict	Observations (Reference to any observations made in Clause E.4)
TC_FT_CC_BV_OC_01	O	Yes/No	Yes/No		
TC_FT_CC_BV_OC_02	O	Yes/No	Yes/No		
TC_FT_CC_BV_OC_03	O	Yes/No	Yes/No		
TC_FT_CC_BV_OC_04	O	Yes/No	Yes/No		
TC_FT_CC_BV_OC_05	O	Yes/No	Yes/No		
TC_FT_CC_BV_IC_01	O	Yes/No	Yes/No		
TC_FT_CC_BV_IC_02	O	Yes/No	Yes/No		
TC_FT_CC_BV_CI_01	O	Yes/No	Yes/No		
TC_FT_CC_BV_CI_02	O	Yes/No	Yes/No		
TC_FT_CC_BV_CI_03	O	Yes/No	Yes/No		
TC_FT_CC_BV_CI_04	O	Yes/No	Yes/No		
TC_FT_CC_BV_CI_05	O	Yes/No	Yes/No		
TC_FT_CC_BV_CI_06	O	Yes/No	Yes/No		
TC_FT_CC_BV_CI_07	O	Yes/No	Yes/No		
TC_FT_CC_BV_CI_08	O	Yes/No	Yes/No		
TC_FT_CC_BV_CI_09	O	Yes/No	Yes/No		
TC_FT_CC_BV_CI_10	O	Yes/No	Yes/No		
TC_FT_CC_BV_CR_01	O	Yes/No	Yes/No		
TC_FT_CC_BV_CR_02	O	Yes/No	Yes/No		
TC_FT_CC_BV_CR_03	O	Yes/No	Yes/No		
TC_FT_CC_BV_CR_04	O	Yes/No	Yes/No		
TC_FT_CC_BV_CR_05	O	Yes/No	Yes/No		
TC_FT_CC_BV_CR_06	O	Yes/No	Yes/No		
TC_FT_CC_BV_CR_07	O	Yes/No	Yes/No		
TC_FT_CC_BV_CR_08	O	Yes/No	Yes/No		
TC_FT_CC_BV_CR_09	O	Yes/No	Yes/No		
TC_FT_CC_BV_CR_10	O	Yes/No	Yes/No		
TC_FT_CC_BV_CR_11	O	Yes/No	Yes/No		
TC_FT_CC_BV_CR_12	O	Yes/No	Yes/No		
TC_FT_CC_BV_RS_07	O	Yes/No	Yes/No		
TC_FT_CC_BV_BO_01	O	Yes/No	Yes/No		
TC_FT_CC_BV_BO_02	O	Yes/No	Yes/No		
TC_FT_CC_BI_01	O	Yes/No	Yes/No		
TC_FT_CC_BI_02	O	Yes/No	Yes/No		
TC_FT_CC_BI_03	O	Yes/No	Yes/No		

(continued)

Table E.3 (continued)

ATS Reference	St.	Selected ?	Run ?	Verdict	Observations (Reference to any observations made in Clause E.4)
TC_FT_CC_BI_04	O	Yes/No	Yes/No		
TC_FT_CC_TI_01	O	Yes/No	Yes/No		
TC_FT_CC_TI_02	O	Yes/No	Yes/No		
TC_FT_CC_TI_03	O	Yes/No	Yes/No		
TC_FT_CC_TI_04	O	Yes/No	Yes/No		
TC_FT_MM_BV_ID_01	O	No	No	-	
TC_FT_MM_BV_AU_01	O	No	No	-	
TC_FT_MM_BV_AU_02	O	No	No	-	
TC_FT_MM_BV_AU_03	O	No	No	-	
TC_FT_MM_BV_AU_04	O	No	No	-	
TC_FT_MM_BV_AU_05	O	No	No	-	
TC_FT_MM_BV_AU_06	O	No	No	-	
TC_FT_MM_BV_LO_01	O	No	No	-	
TC_FT_MM_BV_LO_02	O	No	No	-	
TC_FT_MM_BV_LO_03	O	No	No	-	
TC_FT_MM_BV_LO_04	O	No	No	-	
TC_FT_MM_BV_LO_05	O	No	No	-	
TC_FT_MM_BV_LO_06	O	No	No	-	
TC_FT_MM_BV_AR_01	O	No	No	-	
TC_FT_MM_BV_AR_02	O	No	No	-	
TC_FT_MM_BV_AR_03	O	No	No	-	
TC_FT_MM_BV_AR_06	O	No	No	-	
TC_FT_MM_BV_AR_07	O	No	No	-	
TC_FT_MM_BV_KA_01	O	No	No	-	
TC_FT_MM_BV_KA_02	O	No	No	-	
TC_FT_MM_BV_KA_03	O	No	No	-	
TC_FT_MM_BV_CH_01	O	No	No	-	
TC_FT_MM_BV_CH_02	O	No	No	-	
TC_FT_MM_BV_CH_03	O	No	No	-	
TC_FT_MM_BV_CH_04	O	No	No	-	
TC_FT_MM_BV_CH_05	O	No	No	-	
TC_FT_MM_BO_01	O	No	No	-	
TC_FT_MM_BI_01	O	No	No	-	
TC_FT_MM_BI_02	O	No	No	-	
TC_FT_MM_BI_03	O	No	No	-	
TC_FT_MM_TI_01	O	No	No	-	
TC_FT_MM_TI_02	O	No	No	-	
TC_FT_MM_TI_03	O	No	No	-	
TC_FT_MM_TI_04	O	No	No	-	
TC_FT_MM_TI_05	O	No	No	-	
TC_FT_MM_TI_05	O	No	No	-	
TC_FT_MM_TI_06	O	No	No	-	
TC_FT_MM_TI_07	O	No	No	-	
TC_FT_ME_BV_01	O	No	No	-	
TC_FT_ME_BV_02	O	No	No	-	
TC_FT_ME_BV_03	O	No	No	-	

(continued)

Table E.3 (concluded)

ATS Reference	St.	Selected ?	Run ?	Verdict	Observations (Reference to any observations made in Clause E.4)
TC_FT_ME_BO_01	O	No	No	-	
TC_FT_LC_BV_LE_01	O	Yes/No	Yes/No		
TC_FT_LC_BV_LE_02	O	Yes/No	Yes/No		
TC_FT_LC_BV_LE_03	O	Yes/No	Yes/No		
TC_FT_LC_BV_LR_01	O	Yes/No	Yes/No		
TC_FT_LC_BV_LR_02	O	Yes/No	Yes/No		
TC_FT_LC_BV_LR_03	O	Yes/No	Yes/No		
TC_FT_LC_BV_LR_04	O	Yes/No	Yes/No		
TC_FT_LC_BI_01	O	Yes/No	Yes/No		
TC_FT_LC_BI_03	O	Yes/No	Yes/No		
TC_FT_LC_BI_04	O	Yes/No	Yes/No		
TC_FT_LC_BI_05	O	Yes/No	Yes/No		
TC_FT_LC_BI_06	O	Yes/No	Yes/No		
TC_FT_LC_BI_07	O	Yes/No	Yes/No		
TC_FT_LC_TI_02	O	Yes/No	Yes/No		
TC_FT_LC_TI_03	O	Yes/No	Yes/No		
TC_FT_IS_BV_01	O	No	No	-	
TC_FT_IS_BV_02	O	Yes/No	Yes/No		
TC_FT_IS_BV_03	O	Yes/No	Yes/No		
TC_FT_CL_BV_01	O	No	No	-	
TC_FT_CL_BV_02	O	No	No	-	
TC_FT_CL_BV_03	O	No	No	-	

## E.2 Modifications of DECT DLC layer PCTR proforma

For the requirements of the DECT/ISDN IAP the following modifications shall be applied to the PCTR proforma furnished in ETS 300 497-5 [18] Annex C.

Table E.4 is the replacement table for table C.2 of ETS 300 497-9 [20], subclause C.1.2.

Table E.4

Name:	
Version:	
Protocol specification:	ETS 300 175-4 [3]
PICS:	ETS 300 476-5 [10]
Profile RL:	ETSI ETS 300 705-2 [14]
Previous PCTR if any:	

Table E.5 is the replacement table for table C.3 of ETS 300 497-9 [20], subclause C.1.3.

Table E.5

PIXIT:	ETS 300 497-5 [18]
Profile XRL:	Annex D of this specification (ETSI DE/RES-03018-3)
ATS Specification:	ETS 300 497-5 [18]
Abstract Test Method:	Remote test method, Embedded variant with no UT
Means of Testing identification:	
Date of testing:	
Conformance Log reference(s):	
Retention Date for Log reference(s):	



Table E.6 below is the replacement table for table C.4 of ETS 300 497-9 [20], clause C.6.

The new column "St" indicates the origin of the test case. The value "O" indicates an original unmodified test case. The value "A" indicates an additional test case. The value "R" indicates a replacement test case. The value "M" indicates a test case in which one or more components, such as constraint, behaviour line, etc., are modified. The values "A, R, M" are due to the requirements of the DECT/ISDN IAP profile.

For the values "O" and "M", the corresponding test purposes can be found in the relevant part of the respective standard. For the other values, the corresponding test purposes can be found in this PSTS.

**Table E.6**

ATS Reference	St.	Selected ?	Run ?	Verdict	Observations (Reference to any observations made in clause E.4)
TC-U-CA-000	O	No	No	-	
TC-U-CA-001	O	No	No	-	
TC-U-CA-002	O	No	No	-	
TC-U-CA-003	O	No	No	-	
TC-U-BI-000	O	No	No	-	
TC-U-BI-001	O	No	No	-	
TC-U-BI-002	O	No	No	-	
TC-U-BI-003	O	No	No	-	
TC-U-BI-004	O	No	No	-	
TC-U-BI-005	O	No	No	-	
TC-U-BI-006	O	No	No	-	
TC-U-BI-007	O	No	No	-	
TC-A-CA-000	O	Yes/No	Yes/No		
TC-A-CA-001	O	Yes/No	Yes/No		
TC-A-CA-002	O	Yes/No	Yes/No		
TC-A-CA-003	O	Yes/No	Yes/No		
TC-A-CA-004	O	Yes/No	Yes/No		
TC-A-CA-005	O	Yes/No	Yes/No		
TC-A-CA-006	O	Yes/No	Yes/No		
TC-A-CA-007	O	Yes/No	Yes/No		
TC-A-CA-008	O	Yes/No	Yes/No		
TC-A-BV-000	O	Yes/No	Yes/No		
TC-A-BV-001	O	Yes/No	Yes/No		
TC-A-BV-002	O	Yes/No	Yes/No		
TC-A-BV-003	O	Yes/No	Yes/No		
TC-A-BV-004	O	Yes/No	Yes/No		
TC-A-BV-005	O	Yes/No	Yes/No		
TC-A-BV-006	O	Yes/No	Yes/No		
TC-A-BI-000	O	Yes/No	Yes/No		
TC-A-BI-001	O	Yes/No	Yes/No		
TC-A-BI-002	O	Yes/No	Yes/No		
TC-A-BI-003	O	Yes/No	Yes/No		
TC-A-BI-004	O	Yes/No	Yes/No		
TC-A-BI-005	O	Yes/No	Yes/No		
TC-A-BI-006	O	Yes/No	Yes/No		
TC-A-BI-007	O	Yes/No	Yes/No		
TC-A-BI-008	O	Yes/No	Yes/No		
TC-A-BI-009	O	Yes/No	Yes/No		
TC-A-BI-010	O	Yes/No	Yes/No		
TC-A-BI-011	O	Yes/No	Yes/No		
TC-A-BI-012	O	Yes/No	Yes/No		
(continued)					

Table E.6 (concluded)

ATS Reference	St.	Selected ?	Run ?	Verdict	Observations (Reference to any observations made in clause E.4)
TC-A-BI-013	O	Yes/No	Yes/No		
TC-A-BO-000	O	Yes/No	Yes/No		
TC-A-BO-001	O	Yes/No	Yes/No		
TC-A-BO-002	O	Yes/No	Yes/No		
TC-A-BO-003	O	Yes/No	Yes/No		
TC-L-CA-000	O	Yes/No	Yes/No		
TC-L-CA-001	O	Yes/No	Yes/No		
TC-0-CA-000	O	Yes/No	Yes/No		
TC-0-CA-001	O	Yes/No	Yes/No		
TC-1-CA-000	O	No	No	-	
TC-1-CA-001	O	No	No	-	
TC-1-CA-002	O	No	No	-	
TC-1-BV-000	O	No	No	-	
TC-1-BV-001	O	No	No	-	
TC-1-BV-002	O	No	No	-	
TC-1-BI-000	O	No	No	-	
TC-1-BI-001	O	No	No	-	
TC-1-BI-002	O	No	No	-	

### E.3 Modifications of DECT MAC layer PCTR proforma

For the requirements of the DECT/ISDN IAP the following modifications shall be applied to the PCTR proforma furnished in ETS 300 497-3 [16], annex D.

Table E.7 is the replacement table for table D.2 of ETS 300 497-3 [16], subclause D.1.2.

Table E.7

Name:	
Version:	
Protocol specification:	ETS 300 175-3 [2]
PICS:	ETS 300 476-6 [11]
Profile RL:	ETSI ETS 300 705-2 [14]
Previous PCTR if any:	

Table E.8 is the replacement table for table D.3 of ETS 300 497-3 [16], subclause D.1.3.

Table E.8

PIXIT:	ETS 300 497-3 [16]
Profile XRL:	Annex D of this specification (ETSI DE/RES-03018-3)
ATS Specification:	ETS 300 497-3 [16]
Abstract Test Method:	Remote test method, Embedded variant with no UT
Means of Testing identification:	
Date of testing:	
Conformance Log reference(s):	
Retention Date for Log reference(s):	

Table E.9 is the replacement table for table D.4 of ETS 300 497-3 [16], clause D.6.

The new column "St" indicates the origin of the test case. The value "O" indicates an original unmodified test case. The value "A" indicates an additional test case. The value "R" indicates a replacement test case. The value "M" indicates a test case in which one or more components, such as constraint, behaviour line, etc., are modified. The values "A, R, M" are due to the requirements of the DECT/ISDN IAP profile.

For the values "O" and "M", the corresponding test purposes can be found in the relevant part of the respective standard. For the other values, the corresponding test purposes can be found in this PSTS.

**Table E.9**

ATS Reference	St.	Selected ?	Run ?	Verdict	Observations (Reference to any observations made in clause E.4)
TC_FT_BH_BV_00	O	Yes/No	Yes/No		
TC_FT_BH_BV_01	O	Yes/No	Yes/No		
TC_FT_BH_CA_00	O	Yes/No	Yes/No		
TC_FT_BH_CA_01	O	Yes/No	Yes/No		
TC_FT_BR_CA_00	O	Yes/No	Yes/No		
TC_FT_BR_CA_01	A	Yes/No	Yes/No		
TC_FT_BS_BV_00	O	Yes/No	Yes/No		
TC_FT_BS_BV_01	A	Yes/No	Yes/No		
TC_FT_BS_CA_00	O	Yes/No	Yes/No		
TC_FT_BS_CA_02	A	Yes/No	Yes/No		
TC_FT_DB_BV_03	O	Yes/No	Yes/No		
TC_FT_DB_CA_00	O	Yes/No	Yes/No		
TC_FT_DB_CA_01	O	Yes/No	Yes/No		
TC_FT_DB_CA_02	O	Yes/No	Yes/No		
TC_FT_DB_CA_03	O	Yes/No	Yes/No		
TC_FT_DB_CA_04	O	Yes/No	Yes/No		
TC_FT_DB_CA_05	O	Yes/No	Yes/No		
TC_FT_DB_CA_06	O	Yes/No	Yes/No		
TC_FT_DB_CA_07	O	Yes/No	Yes/No		
TC_FT_DT_BI_00	O	Yes/No	Yes/No		
TC_FT_DT_BI_01	O	Yes/No	Yes/No		
TC_FT_DT_BV_00	O	Yes/No	Yes/No		
TC_FT_DT_BV_01	O	Yes/No	Yes/No		
TC_FT_DT_CA_00	O	Yes/No	Yes/No		
TC_FT_DT_CA_01	O	Yes/No	Yes/No		
TC_FT_DT_CA_02	O	Yes/No	Yes/No		
TC_FT_DT_CA_03	O	Yes/No	Yes/No		
TC_FT_DT_CA_04	O	Yes/No	Yes/No		
TC_FT_LM_CA_05	O	Yes/No	Yes/No		
TC_FT_PG_BV_01	O	Yes/No	Yes/No		
TC_FT_PG_CA_00	O	Yes/No	Yes/No		
TC_FT_PG_CA_01	O	Yes/No	Yes/No		
TC_FT_PG_CA_02	A	Yes/No	Yes/No		



**Annex F (normative): Abstract Test Suite (ATS) for DECT NWK layer conforming to DECT/ISDN IAP profile - Fixed radio Termination (FT)**

The ATS is written in TTCN according to ISO/IEC 9646-3 [24].

As the ATS was developed on a separate TTCN tool the TTCN tables are not completely referenced in the contents table. The ATS itself contains a subclause Test Suite Overview which provides additional information and references about the ATS.

NOTE: According to ISO/IEC 9646-3 [24], in case of a conflict in interpretation of the operational semantics of TTCN.GR and TTCN.MP, the operational semantics of the TTCN.GR representation takes precedence.

**F.1 The machine processable ATS (TTCN.MP)**

The electronic form of the machine processable file (TTCN MP format) corresponding to this ATS is contained in an ASCII text file (DEP7583F.MP<sup>1</sup>) associated with this ETS.

**F.2 The graphical ATS (TTCN.GR)**

The electronic form of the graphical ATS (TTCN GR format) corresponding to this ATS is contained in an PostScript printable text file (DEP7583F.PS<sup>1</sup>) associated with this ETS.

---

1) This file is located in a compressed archive file named 7583\_ep.LZH. Other file formats are available on request.

**Annex G (normative):      Abstract Test Suite (ATS) for DECT DLC layer  
conforming to DECT/ISDN IAP profile - Fixed radio  
Termination (FT)**

The ATS is written in TTCN according to ISO/IEC 9646-3 [24].

As the ATS was developed on a separate TTCN tool the TTCN tables are not completely referenced in the contents table. The ATS itself contains a subclause Test Suite Overview which provides additional information and references about the ATS.

NOTE:      According to ISO/IEC 9646-3 [24], in case of a conflict in interpretation of the operational semantics of TTCN.GR and TTCN.MP, the operational semantics of the TTCN.GR representation takes precedence.

**G.1    The machine processable ATS (TTCN.MP)**

The electronic form of the machine processable file (TTCN MP format) corresponding to this ATS is contained in an ASCII text file (DEP7583G.MP<sup>2</sup>) associated with this ETS.

**G.2    The graphical ATS (TTCN.GR)**

The electronic form of the graphical ATS (TTCN GR format) corresponding to this ATS is contained in an PostScript printable text file (DEP7583G.PS<sup>2</sup>) associated with this ETS.

---

2)    This file is located in a compressed archive file named 7583\_ep.LZH. Other file formats are available on request.

**Annex H (normative): Abstract Test Suite (ATS) for DECT MAC layer conforming to DECT/ISDN IAP profile - Fixed radio Termination (FT)**

The ATS is written in TTCN according to ISO/IEC 9646-3 [24].

As the ATS was developed on a separate TTCN tool the TTCN tables are not completely referenced in the contents table. The ATS itself contains a subclause Test Suite Overview which provides additional information and references about the ATS.

NOTE: According to ISO/IEC 9646-3 [24], in case of a conflict in interpretation of the operational semantics of TTCN.GR and TTCN.MP, the operational semantics of the TTCN.GR representation takes precedence.

**H.1 The machine processable ATS (TTCN.MP)**

The electronic form of the machine processable file (TTCN MP format) corresponding to this ATS is contained in an ASCII text file (DEP7583H.MP<sup>3)</sup>) associated with this ETS.

**H.2 The graphical ATS (TTCN.GR)**

The electronic form of the graphical ATS (TTCN GR format) corresponding to this ATS is contained in an PostScript printable text file (DEP7583H.PS<sup>3)</sup>) associated with this ETS.

---

3) This file is located in a compressed archive file named 7583\_ep.LZH. Other file formats are available on request.

## **Annex I (normative):           Abstract Test Suite (ATS) - DECT/ISDN IAP - Fixed radio Termination (FT)**

The ATS is written in TTCN according to ISO/IEC 9646-3 [24].

As the ATS was developed on a separate TTCN tool the TTCN tables are not completely referenced in the contents table. The ATS itself contains a subclause Test Suite Overview which provides additional information and references about the ATS.

NOTE:       According to ISO/IEC 9646-3 [24], in case of a conflict in interpretation of the operational semantics of TTCN.GR and TTCN.MP, the operational semantics of the TTCN.GR representation takes precedence.

### **I.1    The machine processable ATS (TTCN.MP)**

The electronic form of the machine processable file (TTCN MP format) corresponding to this ATS is contained in an ASCII text file (DEP7583I.MP<sup>4)</sup>) associated with this ETS.

### **I.2    The graphical ATS (TTCN.GR)**

The electronic form of the graphical ATS (TTCN GR format) corresponding to this ATS is contained in an PostScript printable text file (DEP7583I.PS<sup>4)</sup>) associated with this ETS.

---

4) This file is located in a compressed archive file named 7583\_ep.LZH. Other file formats are available on request.



## History

Document history	
June 1996	Public Enquiry PE 107: 1996-06-03 to 1996-09-27