



EUROPEAN
TELECOMMUNICATION
STANDARD

FINAL DRAFT
pr **ETS 300 757**

December 1996

Source: ETSI TC-RES

Reference: DE/RES-03078

ICS: 33.020

Key words: DECT, profile, data, messaging

**Radio Equipment and Systems (RES);
Digital Enhanced Cordless Telecommunications (DECT);
Data Services Profile (DSP);
Low rate messaging service;
(Service type E, class 2)**

ETSI

European Telecommunications Standards Institute

ETSI Secretariat

Postal address: F-06921 Sophia Antipolis CEDEX - FRANCE

Office address: 650 Route des Lucioles - Sophia Antipolis - Valbonne - FRANCE

X.400: c=fr, a=atlas, p=etsi, s=secretariat - **Internet:** secretariat@etsi.fr

Tel.: +33 4 92 94 42 00 - Fax: +33 4 93 65 47 16

Copyright Notification: No part may be reproduced except as authorized by written permission. The copyright and the foregoing restriction extend to reproduction in all media.

© European Telecommunications Standards Institute 1996. All rights reserved.

Contents

Foreword	7
1 Scope	9
2 Normative references	9
3 Definitions and abbreviations	10
3.1 Definitions	10
3.2 Abbreviations	11
4 Description of Services.....	12
4.1 General	12
4.2 Low Rate Messaging Service Point-To-Point (LRMS PTP).....	12
4.3 Low Rate Messaging Service Point-To-Multipoint (LRMS PTM)	13
4.4 Service Objectives	14
5 Point-to-point service, LRMS PTP.....	15
5.1 Reference configuration.....	15
5.2 Functional description	15
5.3 Physical layer requirements	15
5.4 MAC layer requirements	15
5.5 DLC layer requirements.....	15
5.5.1 C-plane requirements.....	15
5.5.2 U-plane requirements.....	16
5.6 Network layer requirements.....	16
5.7 Management Entity Requirements.....	16
5.8 Generic interworking conventions.....	16
5.8.1 MMSP procedures.....	16
5.8.2 Multimedia Messaging Service - Service Access Point (MMS-SAP)	17
5.8.3 MMSP primitives	17
5.8.3.1 C-MMS primitives	17
5.8.3.2 M-MMS primitives	18
5.8.3.3 Parameters	18
6 Point to multipoint service, LRMS PTM.....	18
6.1 Reference configuration.....	18
6.2 Functional description	19
6.2.1 General.....	19
6.2.2 MMS relations to outside networks (horizontal model).....	19
6.2.3 Architecture	19
6.2.4 MMS relations to the upper/lower layers (vertical model)	19
6.2.5 Phases of the horizontal interactions	19
6.3 Physical layer requirements	20
6.4 MAC layer requirements	20
6.5 DLC layer requirements.....	20
6.5.1 C-plane requirements.....	20
6.5.2 U-plane requirements.....	20
6.6 Network layer requirements	20
6.7 Management entity requirements	21
6.8 Generic interworking conventions.....	21
6.8.1 MMSP procedures.....	21
6.8.2 MMS-SAP	21
6.8.3 MMSP primitives	21
6.8.3.1 M-MMS primitives	21
6.8.3.2 Parameters	21
Annex A (normative): Support of MMSP by the DECT lower layers.....	22

A.1	Profile-specific information elements.....	22
A.2	MMSP message implementation.....	22
A.2.1	General.....	22
A.2.2	C-MMS primitives mapping rules	22
A.2.2.1	LRMS PTP C-MMS primitives	22
A.2.2.2	LRMS PTM C-MMS primitives.....	22
A.2.3	M-MMS message mapping rules	22
A.2.3.1	General rules for LRMS PTP	22
A.2.3.2	General rules for LRMS PTM	22
A.2.3.3	Information element mapping rules	23
A.3	Network layer segmentation rules for LRMS PTP	23
A.3.1	Procedure at the sending side.....	23
A.3.2	Procedure at the receiving side.....	23
Annex B (informative):	Interworking conventions to specific networks.....	25
B.1	GSM short message services, SMS Mobile Terminated (SMS-MT), SMS Mobile Originated (SMS-MO) and GSM SMS Cell Broadcast (SMS-CB).....	25
Annex C (normative):	Service E2: fixed termination MAC Protocol Implementation Conformance Statement (PICS) proforma	26
C.1	Standardized symbols for the status column.....	26
C.2	Capabilities	27
C.2.1	Services.....	27
C.2.2	Protocol parameters.....	27
C.2.3	Messages.....	28
C.2.4	Message parameters	30
C.2.5	Functions implemented.....	31
C.2.6	Timer support.....	32
C.2.7	Procedure support.....	32
Annex D (normative):	Service E2: Portable termination MAC PICS proforma	34
D.1	Standardized symbols for the status column.....	34
D.2	Capabilities	35
D.2.1	Services.....	35
D.2.2	Protocol parameters.....	35
D.2.3	Messages.....	36
D.2.4	Message parameters	38
D.2.5	Functions implemented.....	40
D.2.6	Timer support.....	41
D.2.7	Procedure support.....	41
Annex E (normative):	Service E2: Fixed termination DLC PICS proforma.....	43
E.1	Standardized symbols for the status column.....	43
E.2	Capabilities	44
E.2.1	Major capabilities.....	44
E.2.1.1	C-plane capabilities	44
E.2.1.1.1	C-plane services	44
E.2.1.1.2	C-plane procedures	44
E.2.1.1.2.1	Point to point acknowledged operation.....	44
E.2.1.1.2.2	Unacknowledged operation.....	46
E.2.1.1.2.3	Broadcast operation	46
E.2.1.2	Management procedures.....	46
E.2.2	Protocol Data Units (PDUs)	47
E.2.2.1	C-plane PDUs.....	47

	E.2.2.1.1	C-plane frame structure.....	47
	E.2.2.1.2	C-plane messages.....	48
E.2.3	Timers.....		58
	E.2.3.1	C-plane timers.....	58
E.2.4	Protocol error handling.....		58
	E.2.4.1	C-plane protocol error handling.....	58
Annex F (normative): Service E2: Portable termination DLC PICS proforma..... 59			
F.1	Standardized symbols for the status column		59
F.2	Capabilities.....		60
	F.2.1	Major capabilities	60
		F.2.1.1 C-plane capabilities	60
		F.2.1.1.1 C-plane services.....	60
		F.2.1.1.2 C-plane procedures	60
		F.2.1.1.2.1 Point to point acknowledged operation	60
		F.2.1.1.2.2 Unacknowledged operation	61
		F.2.1.1.2.3 Broadcast operation.....	62
	F.2.1.2	Management procedures	62
F.2.2	PDUs.....		63
	F.2.2.1	C-plane PDUs	63
		F.2.2.1.1 C-plane frame structure.....	63
		F.2.2.1.2 C-plane messages.....	64
F.2.3	Timers.....		74
	F.2.3.1	C-plane timers.....	74
F.2.4	Protocol error handling.....		74
	F.2.4.1	C-plane protocol error handling.....	74
Annex G (informative): Profile selection coding..... 75			
G.1	<<BASIC SERVICE>> coding.....		75
G.2	<<IWU-ATTRIBUTES>> coding		75
G.3	<<CONNECTION ATTRIBUTES>> coding.....		75
Annex H (informative): Applicability of ETS 300 755 interworking annexes..... 76			
Annex J (informative): Interworking to other message-based teleservices and application-level services			
			77
J.1	General.....		77
J.2	WWW/HTTP		77
History..... 78			

Blank page

Foreword

This final draft European Telecommunication Standard (ETS) has been produced by the Radio Equipment and Systems (RES) Technical Committee of the European Telecommunications Standards Institute (ETSI), and is now submitted for the Voting phase of the ETSI standards approval procedure.

Proposed transposition dates	
Date of latest announcement of this ETS (doa):	3 months after ETSI publication
Date of latest publication of new National Standard or endorsement of this ETS (dop/e):	6 months after doa
Date of withdrawal of any conflicting National Standard (dow):	6 months after doa

Blank page

1 Scope

This European Telecommunication Standard (ETS) defines a profile for Digital Enhanced Cordless Telecommunications (DECT) systems conforming to ETS 300 175 [1] - [8]. It is part of a family of profiles aimed at the general connection of terminals supporting non-voice services to a fixed infra-structure, private and public.

The Low Rate Messaging Service (LRMS), specified in this ETS, provides a means for the slow, acknowledged or unacknowledged, transfer of multimedia message objects, including alphanumeric paging messages. It provides both point-to-point and point-to-multipoint messaging and exploits the Multimedia Messaging Service (MMS) specified ETS 300 755 [13]. This service may be used for private and public roaming applications.

This ETS specifies the Type E Service, Mobility Class 2, as described in ETR 185 [11]. The service employs solely C-plane functionality and has been designed to coexist with other profiles such as the Generic Access Profile (GAP), ETS 300 444 [9] or the Global System for Mobile communication (GSM) Interworking Profile, ETS 300 370 [10]. No User plane (U-plane) functionality is required for the service.

Interworking with the GSM Short Message Service (SMS) is specifically provided for in an annex of this ETS which cross-references to GSM interworking profile standards (see ETS 300 764 [14]).

This ETS defines the requirements on the Physical (PHL), Medium Access Control (MAC), Data Link Control (DLC) and Network (NWK) layers of DECT. The standard also specifies Management Entity requirements and generic Interworking Conventions which ensure the efficient use of the DECT spectrum.

2 Normative references

This ETS incorporates, by dated or undated reference, provisions from other publications. These normative references are cited at the appropriate places in the text and the publications are listed hereafter. For dated references, subsequent amendments to, or revisions of, any of these publications apply to this ETS only when incorporated in it by amendment or revision. For undated references the latest edition of the publication referred to applies.

- [1] ETS 300 175-1: "Radio Equipment and Systems (RES); Digital European Cordless Telecommunications (DECT); Common Interface (CI); Part 1: Overview".
- [2] ETS 300 175-2: "Radio Equipment and Systems (RES); Digital European Cordless Telecommunications (DECT); Common Interface (CI); Part 2: Physical Layer".
- [3] ETS 300 175-3: "Radio Equipment and Systems (RES); Digital European Cordless Telecommunications (DECT); Common Interface (CI); Part 3: Medium Access Control (MAC) layer".
- [4] ETS 300 175-4: "Radio Equipment and Systems (RES); Digital European Cordless Telecommunications (DECT); Common Interface (CI); Part 4: Data Link Control (DLC) layer".
- [5] ETS 300 175-5: "Radio Equipment and Systems (RES); Digital European Cordless Telecommunications (DECT); Common Interface (CI); Part 5: Network (NWK) layer".
- [6] ETS 300 175-6: "Radio Equipment and Systems (RES); Digital European Cordless Telecommunications (DECT); Common Interface (CI); Part 6: Identities and addressing".
- [7] ETS 300 175-7: "Radio Equipment and Systems (RES); Digital European Cordless Telecommunications (DECT); Common Interface (CI); Part 7: Security features".

- [8] ETS 300 175-8: "Radio Equipment and Systems (RES); Digital European Cordless Telecommunications (DECT); Common Interface (CI); Part 8: Speech coding and transmission".
- [9] ETS 300 444: "Radio Equipment and Systems (RES); Digital European Cordless Telecommunications (DECT); Generic Access Profile (GAP)".
- [10] ETS 300 370: "Radio Equipment and Systems (RES); Digital Enhanced Cordless Telecommunications / Global System for Mobile communications (DECT/GSM) inter-working profile; Access and mapping (Protocol/procedure description for 3,1 kHz speech service)".
- [11] ETR 185: "Radio Equipment and Systems (RES); Digital European Cordless Telecommunications (DECT); Data Services Profile (DSP); Profile overview".
- [12] ETS 300 651: "Radio Equipment and Systems (RES); Digital Enhanced Cordless Telecommunications (DECT); Data Services Profile (DSP); Generic data link service; Service type C, class 2".
- [13] ETS 300 755: "Radio Equipment and Systems (RES); Digital Enhanced Cordless Telecommunications (DECT); Data services profile; Multimedia Messaging Service (MMS) with specific provision for facsimile services; (Service type F, class 2)".
- [14] ETS 300 764: "Radio Equipment and Systems (RES); Digital Enhanced Cordless Telecommunications / Global System for Mobile communications (DECT/GSM) Interworking Profile (IWP); Implementation of short message service, point-to-point and cell broadcast".

3 Definitions and abbreviations

3.1 Definitions

For the purpose of this ETS, the following definitions apply:

kbyte: 1 000 bytes;

Kbyte: 1 024 bytes;

mobility class 1: Local area applications, for which terminals are pre-registered off-air with one or more specific fixed parts, and establishment of service and user parameters is therefore implicit, according to a profile-defined list.

mobility class 2: Private and Public roaming applications for which terminals may move between fixed parts within a given domain and for which association of service parameters is explicit at the time of service request.

multiframe: A repeating sequence of 16 successive Time Division Multiple Access (TDMA) frames, that allows low rate or sporadic information to be multiplexed (e.g. basic system information or paging).

service type A: Low speed frame relay, with a net sustainable throughput of up to 24 kbits/s, optimized for bursty data, low power consumption and low complexity applications such as hand-portable equipment.

service type B: High performance frame relay, with a net sustainable throughput of up to 552 kbits/s, optimized for high speed and low latency with bursty data. Equipment implementing the Type B profile shall inter-operate with Type A equipment.

service type C: Non-transparent connection of data streams requiring Link Access Protocol (LAP) services, optimized for high reliability and low additional complexity. This builds upon the services offered by the type A or B profiles.

service type E: A short message transfer or paging service which may be unacknowledged or acknowledged, optimized for small Service Data Units (SDUs), low Portable Part (PP) complexity and ultra-low power consumption.

service type F: An application profile specifically supporting teleservices such as fax, building upon the services offered by the type A/B and C profiles, optimized for terminal simplicity, spectrum efficiency and network flexibility.

TDMA frame: A time-division multiplex of 10 ms duration, containing 24 successive full slots. A TDMA frame starts with the first bit period of full slot 0 and ends with the last bit period of full slot 23.

3.2 Abbreviations

For the purpose of this ETS, the following abbreviations apply:

ACK	Acknowledgement
CB	Cell Broadcast
CC	Call Control. A network layer functional grouping
C _F	higher layer signalling Channel (Fast)
CLMS	Connectionless Message Service
C-plane	Control Plane
C _S	higher layer signalling Channel (Slow)
DECT	Digital Enhanced Cordless Telecommunications
DLC	Data Link Control. Layer 2b of the DECT protocol stack
FP	Fixed Part
FT	Fixed radio Termination
FTAM	File Transfer Access & Management
FTP	File Transfer Protocol
GAP	Generic Access Profile
GSM	Global System for Mobile communication
HTTP	Hyper Text Transfer Protocol
I _p	higher layer Information channel (Protected)
ISDN	Integrated Services Digital Network
IWF	Interworking Functions
IWU	Interworking Unit
LAP	Link Access Procedure
LAP-B	Link Access Procedure (Balanced)
LAP-C	Link Access Procedure (Control)
LCE	Link Control Entity
LLN	Logical Link Number (DLC layer)
LRMS PTM	Low Rate Messaging Service Point-To-Multipoint
LRMS PTP	Low Rate Messaging Service Point-To-Point
LRMS	Low Rate Messaging Service
M	MAC control channel
MAC	Medium Access Control. Layer 2a of the DECT protocol stack
MCE	Message Control Entity
MCI	MAC Connection Identification
MMSP	Multimedia Messaging Service Protocol
MNCC	Mobile Network Call Control
MO	Mobile Originated
MT	Mobile Terminated
NLF	New Link Flag
NWK	Network. Layer 3 of the DECT protocol stack
P	Paging channel
PDU	Protocol Data Unit
PHL	Physical. Layer 1 of the DECT protocol stack
PICS	Protocol Implementation Conformance Statement
PP	Portable Part
PT	Portable radio Termination
Q	system information channel
RFP	Radio Fixed Part
RFPI	Radio Fixed Part Identifier
SAP	Service Access Point

SAPI	Service Access Point Identifier
SDU	Service Data Unit
SMS	Short Message Service
TDMA	Time Division Multiple Access
UI	Unnumbered Information (Frame)
U-plane	User plane
WWW	World Wide Web

4 Description of Services

4.1 General

The DECT data profile defined in this ETS has been intended for message transfer or paging and is optimized for small SDUs, low PP complexity and ultra-low power consumption. Two service types are defined: Low Rate Messaging Service Point-To-Point (LRMS PTP) which may be unacknowledged or acknowledged used for point-to-point messaging and Low Rate Messaging Service Point-To-Multipoint (LRMS PTM) used for point-to-multipoint messaging. The LRMS PTM is an optional feature while LRMS PTP support is mandatory if this profile is supported.

The LRMS PTP and PTM may co-exist with other profiles and their existence should not have any effect on the functionality of the other existing profiles. That is, the LRMS functionality should have a secondary priority in respect to the profile relations.

4.2 Low Rate Messaging Service Point-To-Point (LRMS PTP)

The objectives of the data profile service type E, class 2 LRMS PTP are as follows:

The LRMS PTP is a generic set of commands, information elements and functionality for file/messaging service. In most of the cases LRMS can be regarded as a DECT internal teleservice that can be interworked to the similar services in external networks. In addition LRMS PTP provides means to convey transparently application specific upper layer protocol frames thus facilitating the usage of this profile as a bearer service. It provides a generic file handling/messaging services over the DECT air interface by utilizing the transportation mechanism of the DECT C-plane in the best way possible while offering a general set of functions to the applications using its services. The LRMS procedures can be accessed in a standardized way through a set of primitives. The LRMS point-to-point service may be acknowledge or unacknowledged.

LRMS provides a compact subset of functions to messaging servers with the advantage that a single terminal with LRMS support can use a wide variety of messaging services with minimum amount of application layer complexity. If a complete set of services is needed an escape sequence has to be used or some other means such as transparent protocol transportation mechanism should be used.

These objectives are fulfilled by Multimedia Messaging Service Protocol (MMSP).

MMSP that is used for the provision of LRMS services and functionality is a stateless protocol which defines a set of messages, framing rules and information elements each containing optional and mandatory information fields.

MMSP utilizes the services of the DECT Call Control entity. It could be regarded as a supplementary service type of service that provides signalling/control and application specific information related to the teleservices provided by the DECT data profiles.

The MMSP layer functionality is provided by a set of specific DECT network layer Call Control information elements. Therefore the MMSP is not from DECT layer viewpoint a separate real protocol layer but a service provided to the application. However, from the application perspective the MMSP can be seen as a protocol layer. Therefore, the MMSP can be regarded as a virtual protocol layer.

The support of MMSP protocol in LRMS PTP is mandatory.

The LRMS PTP is closely aligned with the ETS 300 755 [13] Multimedia Messaging Service (MMS) in the following way:

- the MMSP protocol used by LRMS PTP is the MMSP protocol used by MMS;
- LRMS PTP utilized only the C-plane services; no U-plane is required;
- the LRMS PTP and MMS may co-exist in a same terminal. It is the matter of the implementation if the services of LRMS and MMS are joined or separated i.e. if the messaging is done through the same link or a separate link is instantiated;
- a specific procedure can be used to change the E profile (this ETS) connection into F profile (ETS 300 755 [13]) connection. However, this requires the support of the both profiles as well as additional DECT network layer functionality.

In general the LRMS PTP may receive or send messages during a on-going other profile based call but this requires a separate Call Control (CC) instance.

4.3 Low Rate Messaging Service Point-To-Multipoint (LRMS PTM)

The objectives of data profile service E, class 2 LRMS PTM are as follows:

The purpose of this service is to provide a point-to-multipoint broadcast service of alphanumeric messages from Fixed Part (FP) to PPs. The messages are not acknowledged. With the addressing provided a subset of the receiving PP can be preselected or the messages can be aimed at all PPs in the range of a specific Radio Fixed Part (RFP). Thus the receiving terminals and area can be selected by the DECT FP service provider.

NOTE: For the addressing of the PPs the connectionless TPUI is used.

The LRMS PTM service provides means for sending a subset of MMSP messages over a point-to-multipoint link. This facilitates the usage of standard format messages in both point-to-point and point-to-multipoint cases. With this functionality a network server can control a subgroup of MMSP terminals with single multicast messages without a need of full bi-directional link instantiation. In this way the LRMS PTM facilitates a simple and cost effective means of messaging and remote group control of terminal equipment saving at the same time the air interface resources.

The LRMS PTM may co-exist with other profiles in the PPs and FPs. The co-existence of the LRMS PTM should not have any affect on the functionality of the co-existing profiles.

The support of LRMS PTM is optional and if supported the MMSP support is mandatory.

In general the LRMS PTM may function during a on-going other profile based call.

4.4 Service Objectives

The profile has the service objectives given in table 1 and table 2:

Table 1

Offered services	LRMS PTP	LRMS PTM
point-to-point SDU transfer PP-FP point-to-point SDU transfer FP-PP	Yes	Not supported
point-to-multipoint SDU transfer FP-PP	Not Supported	Yes
Encryption	Optional	Not supported
MMSP support	Mandatory	Mandatory
Profile up/downgrading	Optional	Not Supported
Support in this ETS	Mandatory	Optional

Table 2

Performance	LRMS PTP	LRMS PTM
Maximum throughput for unsegmented messages with minimum header (note 1)	1,38 kbit/s C_S channel 17,6 kbit/s C_f channel, full slot	1,23 kbit/s CL_S channel 15,6 kbit/s CL_f channel full slot
Error rate	$< 10^{-9}$ per bit	$< 10^{-9}$ per bit
Minimum SDU size (note 2)	48 octets	43 octets
SDU size if segmentation used (note 3)	$\leq 5\ 632$ octets	$\leq 4\ 992$ octets
NOTE 1:	The throughput depends strongly on the used control channel and on the other services that are in use simultaneously and these figures are the maximum reachable rates for the user data if no other profiles are in use.	
NOTE 2:	This length is the maximum length of the application layer SDU (user information) if only mandatory elements are used at their minimum length and no network layer segmentation is used.	
NOTE 3:	The maximum supported size is defined in the interworking annexes on a per service basis.	

5 Point-to-point service, LRMS PTP

5.1 Reference configuration

The reference configuration for this profile shall be as shown in figure 1.

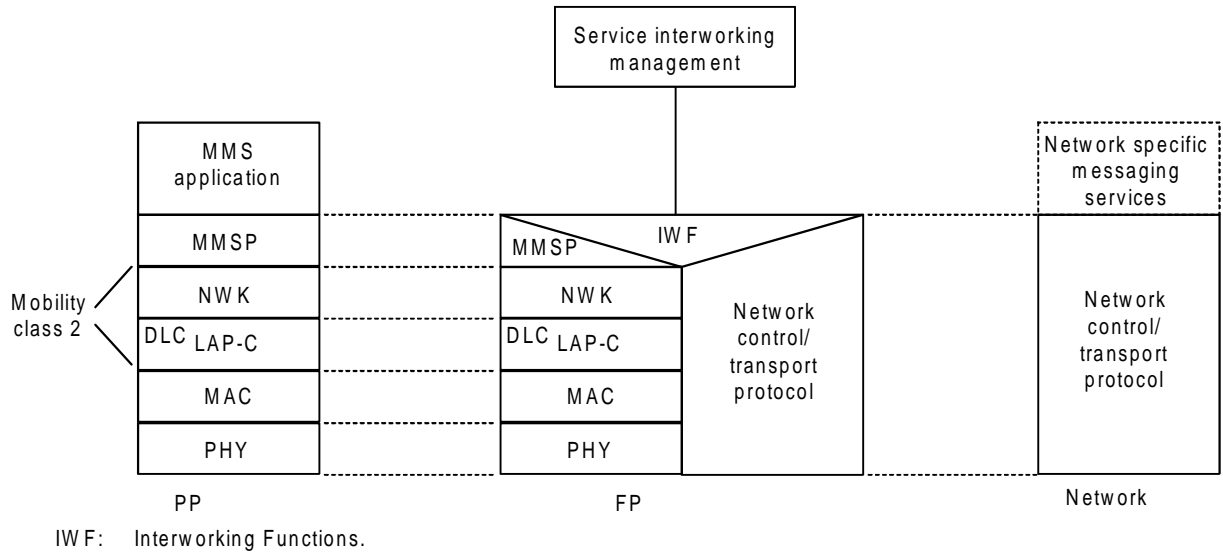

IWF: Interworking Functions.

Figure 1: Profile reference configuration of LRMS PTP showing signalling and message interworking to connectionless networks via the C-plane

5.2 Functional description

The functional description as outlined in clause 5 of ETS 300 755 [13] shall apply.

5.3 Physical layer requirements

The physical layer requirements of ETS 300 444 [9] shall apply.

5.4 MAC layer requirements

The minimum instance shall only require the capability to establish and maintain single-bearer connections. The provisions of ETS 300 175-3 [3] shall be implemented with respect to the services, procedures, messages and information elements coding listed in Annexes C to D with the condition of LRMS PTP. The provisions of ETS 300 175-6 [6] shall be implemented with respect to the structure and use of identities.

The C_F may be used if the co-existing profile provides the channel and the LRMS PTP usage does not noticeably disturb the main profile transmissions. If no other profiles exist then the C_S channel shall be used.

The MAC Extended Fixed Part Information message shall be used and, therefore, bit a12 of the Fixed Part Information field shall be set to 1. In addition, the extended higher layer capabilities bit a43 for the support of the E profile shall be set to 1.

5.5 DLC layer requirements

5.5.1 C-plane requirements

All internal DECT protocol control, all external user data and control shall be handled by the C-plane. The provisions of ETS 300 175-4 [4] shall be implemented with respect to the services, procedures, messages and information elements coding listed in annexes E and F. The minimum supported DLC layer frame length shall be 63 octets.

NOTE: The requirement of the DLC layer C plane is as far as possible compatible with GAP (ETS 300 444 [9]).

5.5.2 U-plane requirements

The U-plane shall not be used by this ETS. However the presence of LRMS PTP service should not noticeably limit the functionality of the possible other coexisting profiles using the U-plane.

5.6 Network layer requirements

The provision of ETS 300 175-5 [5] shall be implemented with respect to the services, procedures, messages and information elements listed in annexes F to G of ETS 300 755 [13], with the condition of LRMS PTP.

NOTE: These network layer requirements are closely related with ETS 300 755 [13] network layer requirements.

The call control entity in FP and PP shall support either packet mode procedures as specified in subclause 9.7 of ETS 300 175-5 [5] and indicated by condition C7 in annexes F and G of ETS 300 651 [12] or circuit mode procedures as specified in ETS 300 444 [9] and indicated by condition C1 in annexes F and G of ETS 300 651 [12]. The used CC procedure is dependent of the interworking profile and therefore defined in appropriate interworking annexes.

The <<IWU-TO-IWU>> information element in the {IWU-INFO} message shall be used to carry the application information in the active state of CC. The messages shall be segmented by using the <<SEGMENTED-INFO>> element in the {IWU-INFO} message if the original {IWU-INFO} message length exceeds 58 octets. The rules for segmentation are specified in clause A.3.

If LRMS PTP is used during ongoing call a separate CC instance shall be required for LRMS.

E/F profile upgrading procedure may optionally be supported. In this case the procedures for the up and downgrading as specified in clause 9 of ETS 300 755 [13] shall apply.

5.7 Management Entity Requirements

The management entity requirements of ETS 300 444 [9] shall apply.

5.8 Generic interworking conventions

5.8.1 MMSP procedures

The MMSP elements of procedures and message definitions are defined in clause A.1 of ETS 300 755 [13].

The MMSP information elements are defined in clause A.2 of ETS 300 755 [13].

The MMSP implementation on lower layers has been defined in annex A of this ETS.

5.8.2 Multimedia Messaging Service - Service Access Point (MMS-SAP)

The MMS-SAP is the service access point on the top of MMSP that shall be accessed by the interworking unit (IWU) or the application. The M-MMS-SAP primitives are used for LRMS call control and for requesting LRMS message transportation or reception directly by the upper layer application. The main call control functionality for different services is done as defined in an appropriate service interworking definition. The MMS-SAP primitives have been defined in subclause 5.8.3 of this ETS.

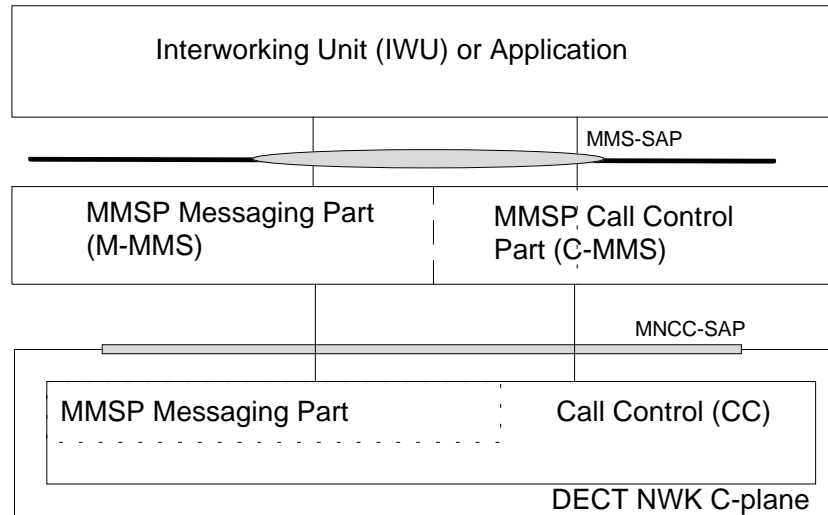

IWU: Interworking Unit.

Figure 2: The LRMS PTP protocol model

5.8.3 MMSP primitives

5.8.3.1 C-MMS primitives

The following primitives are provided by MMS-SAP for the control of C-MMS part of the MMSP.

Primitive	Req	Cfm	Ind	Res
C-MMS-SETUP-	x		x	
C-MMS-CONNECT-	x	x	x	
C-MMS-RELEASE-	x	x	x	x
C-MMS-MODIFY-	x	x	x	

NOTE: C-MMS-MODIFY- primitive is used for F and E profile changes. It can be used only if the functionality is supported.

5.8.3.2 M-MMS primitives

The following primitives are provided by MMS-SAP for the control of M-MMS part of the MMSP.

Primitive	Req	Cfm	Ind	Res
M-MMS-SEND-	X		X	
M-MMS-SEND-REQ	X		X	
M-MMS-SEND-RPY	X		X	
M-MMS-RETRIEVE-	X		X	
M-MMS-RETRIEVE-HDR	X		X	
M-MMS-RETRIEVE-RPY	X		X	
M-MMS-STATUS-	X		X	
M-MMS-STATUS-RPY	X		X	
M-MMS-EXT-CMD-	X		X	
M-MMS-EXT-CMD-RPY	X		X	
M-MMS-ESC-CMD-	X		X	
M-MMS-ESC-CMD-RPY	X		X	

5.8.3.3 Parameters

The parameters for each primitive are described in clause A.3 of the of ETS 300 755 [13].

6 Point to multipoint service, LRMS PTM

6.1 Reference configuration

The reference configuration for this profile shall be as shown in figure 3.

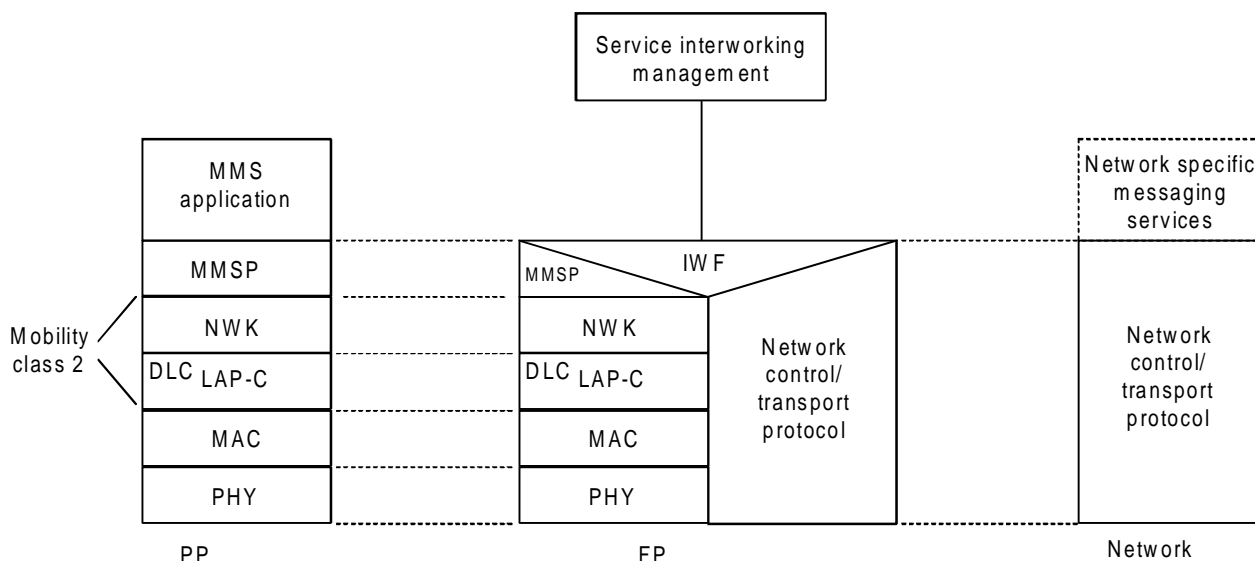

Figure 3: Profile reference configuration of LRMS PTM showing signalling and message interworking to connectionless networks via the C-plane

6.2 Functional description

6.2.1 General

The functional description as outlined in clause 5 of ETS 300 755 [13] shall apply with the exceptions outlined in this subclause.

6.2.2 MMS relations to outside networks (horizontal model)

The model defined in the subclause 5.2 of ETS 300 755 [13] shall apply with the following rules:

- the messaging direction is always from MCE to portable MMS entity. Due to this no IWU conversion can be requested in FP IWU or MCE IWU with MMSP messages;
- the MCE as well as the fixed MMS entity may do implicit IWU conversions but this conversion cannot be controlled with MMSP;
- only such MMS procedures are available that are allowed in the direction of fixed MMS entity to portable MMS entity. The portable MMS entity cannot control the MCE messaging;
- the End Entity may send message only to the MMS entities;
- the addressing of a group of portable entities shall be done in the fixed entity by mapping the incoming address to the PTM as specified in each interworking descriptions.

The point to multipoint MMS messaging horizontal functional model has been illustrated in figure 4.

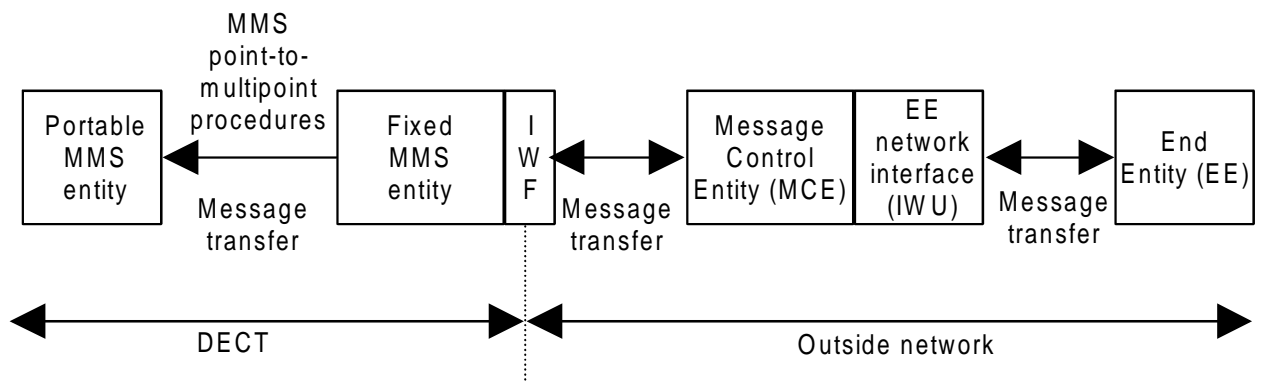

Figure 4: The MMS horizontal functional model for point-to-multipoint service

6.2.3 Architecture

The internal architecture of the MMSP layer as defined in ETS 300 755 [13], subclause 5.3 shall apply with the exception that the C-MMS part is not required in the LRMS PTM service. That is, the M-MMS part interacts directly with the DECT upper layer as illustrated in figure 5. No connection establishment phase is required on MMSP layer.

6.2.4 MMS relations to the upper/lower layers (vertical model)

The model defined in the subclause 5.4 of ETS 300 755 [13] shall apply.

6.2.5 Phases of the horizontal interactions

Only the phase 3 b) of the horizontal interaction of PP terminated incoming MMS call as defined in subclause 5.5.2.3 of ETS 300 755 [13] shall apply.

6.3 Physical layer requirements

The physical layer requirements of the Generic Access Profile (GAP), ETS 300 444 [9] shall apply.

6.4 MAC layer requirements.

The minimum instance shall only require the capability to establish and maintain single-bearer connections. The provisions of ETS 300 175-3 [3] shall be implemented with respect to the services, procedures, messages and information elements coding listed in Annexes C to D of this ETS with reference to LRMS PTM. The provisions of ETS 300 175-6 [6] shall be implemented with respect to the structure and use of identities. The Fixed radio Termination (FT) and Portable radio Termination (PT) shall support the downlink connectionless procedure as defined in ETS 300 175-3 [3].

FT and PT shall support either the CL_S or CL_F channel. The CL_F may be used if the co-existing profile provides the channel and the LRMS PTM usage does not noticeably disturb the main profile transmissions. If no other profiles exist then the CL_S channel shall be used.

The broadcast attributes coding for CLMS, bit a42 shall be set to 1.

6.5 DLC layer requirements

6.5.1 C-plane requirements

All internal DECT protocol control shall be handled by the C-plane. All external user data and control shall be handled by the C-plane. The provisions of ETS 300 175-4 [4] shall be implemented with respect to the services, procedures, messages and information elements coding listed in Annexes E to F of this ETS with the condition of LRMS PTM. The DLC layer Link Access Procedure (Control) (LAP-C) class U operation shall be supported. The Unnumbered Information (UI) frames shall be fragmented to use either the CL_S or CL_F channel. The minimum supported DLC layer frame length shall be 63 octets.

6.5.2 U-plane requirements

The U-plane shall not be used by this ETS. However the presence of LRMS PTM service should not noticeably limit the functionality of the possible other coexisting profiles using the U-plane.

6.6 Network layer requirements

The provisions of ETS 300 175-5 [5] shall be implemented with respect to the services, procedures, messages and information elements coding listed in annexes F and G of ETS 300 755 [13], with the condition of LRMS PTM.

The Network layer provisions shall include the Connectionless Message Service (CLMS) entity. For the service the rules of the clause 12 of ETS 300 175-5 [5] variable length service shall apply.

The <<PORTABLE IDENTITY>> element of the {CLMS-VARIABLE} message shall be used for the addressing. For the addressing of the PPs the connectionless TPUI shall be used as specified ETS 300 175-5 [5], subclause 14.3 (see particularly subclause 14.3.2 paragraph 4). The interworking annexes to specific services shall define the type of addressing used as well as the way external addresses are mapped into the DECT addresses.

The inclusion of the <<IWU-TO-IWU>>, <<MMS-GENERIC-HDR >> and <<MMS-OBJECT-HDR>> shall be required in the {CLMS-VARIABLE} message.

The messages shall be segmented by using the <<SEGMENTED-INFO>> element in the {CLMS-VARIABLE} message if the {CLMS-VARIABLE} message length exceeds 58 octets. The segmentation rules as specified in ETS 300 175-5 [5] in subclauses 12.3.2.1 and 12.3.2.2 shall apply. For the segmentation procedure the elements defined mandatory in {CLMS-VARIABLE} in ETS 300 175-5 [5] shall be present in all messages. The segmentation shall apply to the << IWU-TO-IWU>> element only.

NOTE: This implies that other elements, such as the <<MMS-GENERIC-HDR>> and <<MMS-OBJECT-HDR>>, are not duplicated for subsequent {CLMS-VARIABLE} messages when segmentation is used.

6.7 Management entity requirements

The connectionless link procedures shall be provided.

6.8 Generic interworking conventions

6.8.1 MMSP procedures

The MMSP elements of procedures and message definitions are defined in clause A.1 of ETS 300 755 [13]. Only {MMS-SEND}, {MMS-STATUS}, {MMS-EXT-CMD} and {MMS-ESC-CMD} message shall be supported.

The MMSP information elements are defined in clause A.2 of ETS 300 755 [13].

The MMSP implementation on lower layers has been defined in annex A of this ETS.

6.8.2 MMS-SAP

The MMS-SAP is the service access point on the top of MMSP that shall be accessed by the interworking unit (IWU) or the application. The M-MMS-SAP primitives are used for LRMS message control and for requesting LRMS message transportation or reception directly by the upper layer application. The main message control functionality for different services is done as defined in an appropriate service interworking definition. The MMS-SAP primitives for LRMS PTM have been defined in subclause 6.8.3 of this ETS.

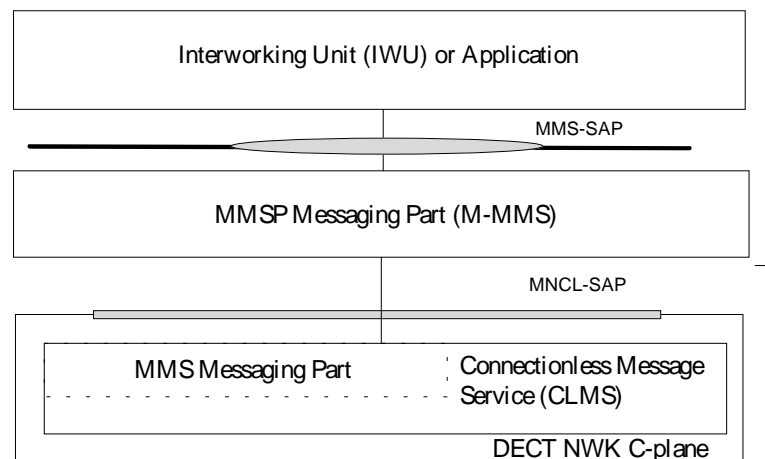

Figure 5: The LRMS PTM protocol model

6.8.3 MMSP primitives

6.8.3.1 M-MMS primitives

The following primitives are provided by MMS-SAP for the control of M-MMS part of the MMSP.

Primitive	Req	Cfm	Ind	Res
PTM-MMS-SEND-	x		x	
PTM-MMS-STATUS-	x		x	
PTM-MMS-EXT-CMD-	x		x	
PTM-MMS-ESC-CMD-	x		x	

6.8.3.2 Parameters

The parameters for each primitive are described in clause A.2 of ETS 300 755 [13].

Annex A (normative): Support of MMSP by the DECT lower layers

A.1 Profile-specific information elements

The information elements specified in clause B.1 of annex B in data service profile F, class 2 (ETS 300 755 [13]) shall apply for both services LRMS PTP and PTM.

A.2 MMSP message implementation

A.2.1 General

This annex describes the implementation of the MMSP point-to-point and point-to-multipoint service in DECT. The implementation is illustrated in the form of mappings between the MMSP and DECT NWK layer elements.

The M-MMS messages specified in ETS 300 755 [13], annex A shall apply.

A.2.2 C-MMS primitives mapping rules

A.2.2.1 LRMS PTP C-MMS primitives

There is no concept of "C-MMS messages". Therefore C-MMS primitives are directly mapped to Mobile Network Call Control (MNCC) primitives.

The mapping shall be as follows as follows:

Table A.1. Primitive mapping between C-MMS and CC

MMS primitive	MNCC primitive
C-MMS-SETUP- {req, ind}	MNCC-SETUP- {req, ind}
C-MMS-CONNECT- {req, cfm, ind}	MNCC-CONNECT- {req, cfm, ind}
C-MMS-RELEASE- {req, cfm, ind, res}	MNCC-RELEASE- {req, cfm, ind, res}
C-MMS-MODIFY- {req, cfm, ind}	MNCC-MODIFY- {req, cfm, ind}

The parameters of corresponding primitives are identical.

A.2.2.2 LRMS PTM C-MMS primitives

No C-MMS part is present in the LRMS PTM thus no C-MMS primitives are defined nor mapped.

A.2.3 M-MMS message mapping rules

A.2.3.1 General rules for LRMS PTP

The primary part of an M-MMS message shall be placed into an {IWU-INFO} message.

The User data field of the secondary part shall be carried in the {IWU-INFO} message. Other fields of the secondary part shall not be conveyed.

A.2.3.2 General rules for LRMS PTM

These rules shall apply if MMSP messages are conveyed over the connectionless point to multipoint link.

The primary part of an M-MMS message shall be placed into an {CLMS-VARIABLE} message.

The User data field of the secondary part shall be carried in the {CLMS-VARIABLE} message. Other fields of the secondary part shall not be conveyed.

A.2.3.3 Information element mapping rules

The following M-MMS information elements shall be mapped one to one on to elements with the same name in the network layer.

Table A.2. M-MMS information elements mapping

M-MMS information element	Reference
MMS-Generic-Header	ETS 300 755 [13], B.1.1
Called-Party-Number	ETS 300 175-5 [5], 7.7.7.
Called party Subaddress	ETS 300 175-5 [5], 7.7.8.
Calling Party Number	ETS 300 175-5 [5], 7.7.9.
Time-Date	ETS 300 175-5 [5], 7.7.50
MMS-Obj-Header	ETS 300 755 [13], B.1.2.,
MMS-Ext-Header	ETS 300 755 [13], B.1.3
Segmented Info	ETS 300 175-5 [5], 7.7.37.
Repeat Indicator	ETS 300 175-5 [5], 7.6.3

The user data M-MMS information element shall be mapped as follows:

Table A.3. M-MMS user data element mapping

M-MMS information element	NWK information element	Reference
User data	IWU-TO-IWU with <protocol discriminator> "M-MMS user data" user data is mapped into the IWU-TO-IWU-INFORMATION field	ETS 300 175-5 [5], 7.7.23

A.3 Network layer segmentation rules for LRMS PTP

A.3.1 Procedure at the sending side

Upon receipt of a MNCC-IWU-INFO-req primitive the CC shall map the parameters into {IWU-INFO} message elements. The original message shall be segmented into two or more {IWU-INFO} messages by using the <<SEGMENTED-INFO>> element in the {IWU-INFO} message if the original message length exceeds 58 octets. For the segmentation procedure the elements defined mandatory in {IWU-INFO} message in ETS 300 175-5 5 shall be present in all messages and shall have the same value. The segmentation shall apply to the << IWU-TO-IWU>> element only. Each message should contain the maximum amount of user data.

NOTE: This implies that other elements, such as the <<MMS-GENERIC-HDR >> and <<MMS-OBJECT-HDR >>, are not duplicated for subsequent {IWU-INFO} messages when segmentation is used.

The CC shall deliver the resulting {IWU-INFO} message (or series of messages) in sequence to the Link Control Entity (LCE) for immediate delivery via the connection oriented S-SAP (Service Access Point Identifier (SAPI) = "0"). The messages shall be delivered using DL-DATA-req primitives, indicating the use of a class A link.

A.3.2 Procedure at the receiving side

Upon receipt of a {IWU-INFO} message, the CC shall act as follows.

- a) if the message does not contain the <<SEGMENTED-INFO>> information element it shall map the elements into the parameters of a MNCC-IWU-INFO-ind primitive. It shall immediately issue the resulting primitive via the MNCC-SAP;

- b) if the message does contain the <<SEGMENTED-INFO>> element the CC shall store (buffer) the this message. Whenever a new segmented message is received, the CC shall attempt to construct a original message using all stored segmented messages. Any duplicate segmented messages should be discarded.

The reconstructed original message shall be identified by the receipt of all of the segments as indicated in the <<SEGMENTED-INFO>> elements. Upon detection of a complete series of segments, the CC shall map the elements into the parameters of a MNCC-IWU-INFO-ind primitive. Duplicate mandatory elements and all <<SEGMENTED-INFO>> elements shall be discarded, and the individual <<IWU-TO-IWU>> elements shall be concatenated into a single message unit parameter. The CC shall immediately issue the resulting primitive via the MNCC-SAP.

Annex B (informative): Interworking conventions to specific networks**B.1 GSM short message services, SMS Mobile Terminated (SMS-MT), SMS Mobile Originated (SMS-MO) and GSM SMS Cell Broadcast (SMS-CB)**

The interworking description of the LRMS (this profile) to the GSM Short message service, point-to-point mobile originated and mobile terminated and GSM short message service cell broadcast is defined in ETS 300 764 [14].

Annex C (normative): Service E2: fixed termination MAC Protocol Implementation Conformance Statement (PICS) proforma

Notwithstanding the provisions of the copyright clause related to the text of this ETS, ETSI grants that users of this ETS may freely reproduce the PICS proforma in this annex so that it can be used for its intended purposes and may further publish the completed PICS.

C.1 Standardized symbols for the status column

The standardized symbols for the status column are as follows:

- m or M for mandatory;
- o or O for optional (Boolean);
- x or N/A for prohibited use;
- n/a, N/A or - (dash) for not applicable;
- cn or Cn for conditional on the implementation of feature n;
- i or I for out of scope (the capability is allowed to be implemented but is not called upon by the profile functionality).

Where reception of a message is marked as "O", this shall be understood to mean that correct understanding and processing of that message is optional.

C1: IF Encryption supported THEN C1=M

C2m: IF LRMS PTP (point to point) service supported THEN C2m=M ELSE I

C2o: IF LRMS PTP (point to point) service supported THEN C2o=O ELSE I

C3m: IF protected B-field available THEN C3m=M ELSE I

C3o: IF protected B-field available THEN C3o=O ELSE I

C3: IF protected B-field available THEN 1 else 0,1

C4: IF LRMS PTP (point to point) service supported AND protected B-field available THEN M ELSE I

C5m: IF LRMS PTM (point to multipoint) service supported THEN C5m = M ELSE I

C5o: IF LRMS PTM (point to multipoint) service supported THEN C5o = O ELSE I

C5h: IF LRMS PTM (point to multipoint) service supported THEN C5h = 1 ELSE 0, 1

C5l: IF LRMS PTM (point to multipoint) service supported THEN C5l = 0 ELSE 0, 1

C6: IF LRMS PTM (point to multipoint) service supported AND protected B-field available THEN M ELSE I

Except when stated otherwise, the reference column refers to the relevant subclause in ETS 300 175-3 [3].

C.2 Capabilities

C.2.1 Services

Q.9 Service support

Service supported				
Item no.	Name of service	Ref.	Status	Support
1	Type 1f IN_minimum delay	5.6.2.1	I	
2	Type 2f IN_normal delay	5.6.2.1	I	
3	Type 3f IP_error_detection	5.6.2.1	I	
4	Type 4f IP_error_correction	5.6.2.1	I	
5	Type 5 IN_normal delay	5.6.2.2	I	
6	Type 6 IP_error_detection	5.6.2.2	I	
7	Type 7f IP_error_correction	5.6.2.2	I	
8	Type 1h IN_minimum delay	5.6.2.1	I	
9	Type 2h IN_normal delay	5.6.2.1	I	
10	Type 3h IP_error_detection	5.6.2.1	I	
11	Type 4h IP_error_correction	5.6.2.1	I	
12	CS duplex	5.3.1.1	C2m	
13	CF duplex	5.3.1.1	C3m	
14	Downlink CLS only	5.7.2.1	C5m	
15	Downlink CLF + CLS	5.7.2.1	C6	
16	Downlink CLS + SIN	5.7.2.1	I	
17	Uplink CLF only	5.7.2.2	I	
18	Uplink CLS only	5.7.2.2	I	
19	Uplink without SDU	5.7.2.2	I	
20	GF simplex	5.3.1.3	I	
21	Fast paging	11.3.3.1	O	
22	Normal paging	11.3.3.1	M	
23	Low duty cycle paging	11.3.3.1	O	
24	System identities	11.3.2	M	
25	System information	11.3.2	M	
26	Encryption	6.2.3	C1	
27	Fast setup	11.3.3.2	I	
IP: higher layer Information channel (Protected).				

C.2.2 Protocol parameters

Q.11 Protocol parameters

Protocol parameters supported						
Item no.	Name	Ref.	Status	Support	Value	
					Allowed	Supported
1	N200	10.2	C2m		10	
2	N201	10.6	I			
3	N202	11.4	M		10	
4	N203	9.2	I			

C.2.3 Messages

Q.12 Messages in A_tail

Supported messages						
Item no.	Name	Ref.	Sending		Receipt	
			Status	Support	Status	Support
1	TA code: CT data packet number 0	7.1.2	M		M	
2	TA code: CT data packet number 1	7.1.2	M		M	
3	TA code: identities information on connectionless bearer	7.1.2	M		N/A	
4	TA code: identities information	7.1.2	M		M	
5	TA code: multiframe sync. and system information	7.1.2	M		N/A	
6	TA code: main escape	7.1.2	X		X	
7	TA code: MAC layer control	7.1.2	M		M	
8	TA code: paging/first PT transmission	7.1.2	M		M	
9	BA code: U-type, IN, SIN or IP packet number 0	7.1.4	I		I	
10	BA code: U-type, IP error detect or IP packet number 1	7.1.4	I		I	
11	BA code: E-type, all CF or CLF, packet number 0	7.1.4	C3m		C3m	
12	BA code: E-type, all CF, packet number 1	7.1.4	C3m		C3m	
13	BA code: E-type, not all CF or CLF; CF packet number 0	7.1.4	C3m		C3m	
14	BA code: E-type, not all CF; CF packet number 1	7.1.4	C3m		C3m	
15	BA code: E-type, all MAC control	7.1.4	I		I	
16	BA code: no B_field	7.1.4	O		N/A	
17	NT information	7.2.2	M		M	
18	Static system information	7.2.3.2	M		N/A	
19	Extended RF carrier information	7.2.3.3	I		N/A	
20	Fixed part capabilities	7.2.3.4	M		N/A	
21	Extended fixed part capabilities	7.2.3.5	I		N/A	
22	SARI message	7.2.3.6	O		N/A	
23	Multi-frame number	7.2.3.7	C1		N/A	
24	Q-channel escape	7.2.3.8	I		N/A	
25	Zero length page indication	7.2.4.2.3	M		N/A	
26	Short page indication	7.2.4.2.3	M		N/A	
27	Full page indication	7.2.4.2.3	I		N/A	
28	Not the last 36 bits of a long page indication	7.2.4.2.3	I		N/A	
29	The first 36 bits of a long page indication	7.2.4.2.3	I		N/A	
30	The last 36 bits of a long page indication	7.2.4.2.3	I		N/A	
31	All of a long page indication	7.2.4.2.3	I		N/A	
32	PT header extend flag	7.2.4.2.2	M		N/A	
33	PT MAC information: fill	7.2.4.3.2	O		N/A	
34	PT MAC information: blind full slot	7.2.4.3.3	M		N/A	
35	PT MAC information: other bearer	7.2.4.3.4	O		N/A	
36	PT MAC information: recommended other bearer	7.2.4.3.4	O		N/A	
37	PT MAC information: good RFP bearer	7.2.4.3.4	O		N/A	
38	PT MAC information: dummy or C/L bearer position	7.2.4.3.4	M		N/A	
39	PT MAC information: RFP identity	7.2.4.3.5	I		N/A	
40	PT MAC information: dummy or C/L bearer marker	7.2.4.3.7	M		N/A	
41	PT MAC information: escape	7.2.4.3.6	I		N/A	
42	PT MAC information: bearer handover type 0000	7.2.4.3.8	I		N/A	
43	PT MAC information: bearer handover type 0001	7.2.4.3.8	I		N/A	
44	PT MAC information: bearer handover type 0010	7.2.4.3.8	I		N/A	
45	PT MAC information: bearer handover type 0011	7.2.4.3.8	I		N/A	
46	Basic access request	7.2.5.2	N/A		C2m	
47	Basic bearer handover request	7.2.5.2	N/A		I	

(continued)

Q.12 Messages in A_tail (concluded)

Supported messages						
Item no.	Name	Ref.	Sending		Receipt	
			Status	Support	Status	Support
48	Basic connection handover request	7.2.5.2	N/A		I	
49	Basic unconfirmed access request	7.2.5.2	N/A		I	
50	Basic bearer confirm	7.2.5.2	C2m		N/A	
51	Basic wait	7.2.5.2.3	C2m		I	
52	Basic bearer release	7.2.5.2	C2m		I	
53	Advanced access request	7.2.5.3.2	I		I	
54	Advanced bearer handover request	7.2.5.3.3	I		I	
55	Advanced connection handover request	7.2.5.3.4	I		I	
56	Advanced bearer confirm	7.2.5.3.6	I		I	
57	Advanced unconfirmed access request	7.2.5.3.5	I		I	
58	Advanced wait	7.2.5.3.7	I		I	
59	Advanced attributes-T request	7.2.5.3.8	I		I	
60	Advanced attributes-T confirm	7.2.5.3.8	I		I	
61	Advanced bandwidth-T request	7.2.5.3.9	I		I	
62	Advanced bandwidth-T confirm	7.2.5.3.9	I		I	
63	Advanced channel list	7.2.5.3.10	I		I	
64	Advanced unconfirmed dummy	7.2.5.3.11	I		I	
65	Advanced unconfirmed handover	7.2.5.3.12	I		I	
66	Advanced bearer release	7.2.5.3.13	I		I	
67	Transmit on the specified slot/frequency test message	7.2.5.4.2	N/A		I	
68	Loopback B_field test message	7.2.5.4.3	N/A		I	
69	Defeat antenna diversity test message	7.2.5.4.4	N/A		I	
70	Force bearer handover test message	7.2.5.4.5	N/A		I	
71	Clear test mode test message	7.2.5.4.6	N/A		I	
72	Single bearer antenna switch QC message	7.2.5.5	O		O	
73	All bearer antenna switch QC message	7.2.5.5	O		O	
74	Bearer handover QC message	7.2.5.5	I		I	
75	Connection handover QC message	7.2.5.5	I		I	
76	Single bearer frequency control QC message	7.2.5.5	O		O	
77	All bearer frequency control QC message	7.2.5.5	O		O	
78	C/L single transmission with 1 CLF segment	7.2.5.6	C6		C6	
79	C/L single transmission with 2 CLF segments	7.2.5.6	C6		C6	
80	C/L single transmission with 3 CLF segments	7.2.5.6	C6		C6	
81	C/L single transmission with 4 CLF segments	7.2.5.6	C6		C6	
82	1st C/L half slot transmission with 1 CLF segment	7.2.5.6	I		I	
83	1st C/L full slot transmission with 4 CLF segment	7.2.5.6	C6		C6	
84	2nd C/L transmission with 1 CLF segment	7.2.5.6	C6		C6	
85	2nd C/L transmission with 2 CLF segment	7.2.5.6	C6		C6	
86	2nd C/L transmission with 3 CLF segment	7.2.5.6	C6		C6	
87	2nd C/L transmission with 4 CLF segment	7.2.5.6	C6		C6	
88	C/L single transmission without CLF segment	7.2.5.6	C3m		C3m	
89	1st C/L transmission without CLF segment (CLS service)	7.2.5.6	C3m		C3m	
90	Change dummy position	7.2.5.6	N/A		O	
91	Extended system information	7.2.5.6	N/A		O	
92	Start encryption: request	7.2.5.7	N/A		C1	
93	Start encryption: confirm	7.2.5.7	C1		N/A	
94	Start encryption: grant	7.2.5.7	N/A		C1	
95	Stop encryption: request	7.2.5.7	N/A		C1	
96	Stop encryption: confirm	7.2.5.7	C1		N/A	
97	Stop encryption: grant	7.2.5.7	N/A		C1	
98	First transmission for B_field setup	7.2.5.8	I		I	
99	M-channel escape	7.2.5.9	I		I	

C.2.4 Message parameters

Q.14 Parameters of static system information message

Supported parameters						
Item no.	Parameter	Ref.	Status	Support	Values	
					Allowed	Supported
1	Normal-reverse	7.2.3.2.2	M		0	
2	Slot number	7.2.3.2.3	M		0 - 11	
3	Start position	7.2.3.2.4	M		0	
4	Escape	7.2.3.2.5	M		0 - 1	
5	Number of transceivers	7.2.3.2.6	M		0 - 3	
6	Extended RF carrier flag	7.2.3.2.7	M		0	
7	RF carriers available	7.2.3.2.8	M		1 - 1 023	
8	Spare	7.2.3.2.11	M		0	
9	Carrier number	7.2.3.2.10	M		0 - 9	
10	Spare	7.2.3.2.11	M		0	
11	Primary receiver scan number	7.2.3.2.12	M		0 - 9	

Q.15 Parameters of fixed part capabilities message

Fixed part capabilities						
Item no.	Parameter	Ref.	Status	Support	Values	
					Allowed	Supported
1	Extended FP information	7.2.3.4.2	M		0, 1	
2	Full slot	7.2.3.4.2	M		0, 1	
3	Frequency control	7.2.3.4.2	M		0, 1	
4	Page repetition	7.2.3.4.2	M		0, 1	
5	C/O setup on dummy allowed	7.2.3.4.2	M		C5l	
6	C/L uplink	7.2.3.4.2	M		0, 1	
7	C/L downlink	7.2.3.4.2	M		C5h	
8	Basic A_field setup	7.2.3.4.2	M		C2	
9	Advanced A_field setup	7.2.3.4.2	M		0, 1	
10	B_field setup	7.2.3.4.2	M		0, 1	
11	CF messages	7.2.3.4.2	M		C3	
12	IN_minimum_delay	7.2.3.4.2	M		0, 1	
13	IN_normal_delay	7.2.3.4.2	M		0, 1	
14	IP_error_detection	7.2.3.4.2	M		0, 1	
15	IP_error_correction	7.2.3.4.2	M		0, 1	
16	Multibearer connection	7.2.3.4.2	M		0, 1	

C.2.5 Functions implemented

Q.34 Function implemented

Supported functions				
Item no.	Function name	Ref.	Status	Support
1	B_field data scrambling	6.2.4	C3m	
2	B_field data unscrambling	6.2.4	C3m	
3	R-CRC generation	6.2.5.2	M	
4	R-CRC checking	6.2.5.2	M	
5	X-CRC generation	6.2.5.4	C3m	
6	X-CRC checking	6.2.5.4	C3o	
7	Z-CRC generation	ETS 300 175-2 [2] 4.8	I	
8	Z-CRC checking	ETS 300 175-2 [2] 4.8	I	
9	D-MAP D80 field mapping	6.2.1.1	I	
10	D-MAP D32 field mapping	6.2.1.1	C3m	
11	D-MAP D08 field mapping	6.2.1.1	I	
12	D-MAP D00 field mapping	6.2.1.1	M	
13	A-MAP A_field mapping	6.2.1.2	M	
14	E/U-MUX E80 type multiplex	6.2.2.2	I	
15	E/U-MUX E32 type multiplex	6.2.2.2	C3m	
16	E/U-MUX E08 type multiplex	6.2.2.2	I	
17	E/U-MUX U80a type multiplex	6.2.2.2	I	
18	E/U-MUX U80b type multiplex	6.2.2.2	I	
19	E/U-MUX U32a type multiplex	6.2.2.2	C2m	
20	E/U-MUX U32b type multiplex	6.2.2.2	C3o	
21	E/U-MUX U08a type multiplex	6.2.2.2	I	
22	E/U-MUX U08b type multiplex	6.2.2.2	I	
23	C-MUX B_field full slot mode 0 multiplex	6.2.2.3.1	C3m	
24	C-MUX B_field full slot mode 1 multiplex	6.2.2.3.1	C3m	
25	C-MUX B_field full slot mode 2 multiplex	6.2.2.3.1	C3m	
26	C-MUX B_field full slot mode 3 multiplex	6.2.2.3.1	C3m	
27	C-MUX B_field full slot mode 4 multiplex	6.2.2.3.1	C3m	
28	C-MUX B_field half slot mode 0 multiplex	6.2.2.3.2	I	
29	C-MUX B_field half slot mode 1 multiplex	6.2.2.3.2	I	
30	T-MUX Tail multiplex	6.2.2.1.2	M	
31	Frequency correction function	11.5.2.2	O	

C.2.6 Timer support

Q.35 Timer support

Timer supported						
Item no.	Name	Ref.	Status	Support	Values	
					Allowed	Supported
1	T200	10.2	C2m		3 seconds	
2	T201	11.5	C2m		5 seconds	
3	T202	10.6	I		3 seconds	
4	T203	10.6	I		16 frames	
5	T204	9.1	M		6 multiframe	
6	T205	9.1	M		10 seconds	
7	T206	11.2	I		10 frames	
8	T207	11.3	N/A		5 seconds	
9	T208	11.3	N/A		20 seconds	
10	T209	11.4	M		30 seconds	
11	T210	11.4	M		2 seconds	
12	T211	10.3	I		3 seconds	
13	T212	10.5	I		20 frames	
14	T213	10.7	I		20 frames	
15	T214	9.2	I		20 frames	
16	T215	9.2	I		6 multiframe	

C.2.7 Procedure support

Q.36 Procedure support

Procedures supported				
Item no.	Name of procedure	Ref.	Status	Support
1	Downlink connectionless procedure	9.1.2	C5m	
2	Downlink broadcast procedure	9.1.1	M	
3	Uplink connectionless procedure	9.2.3	I	
4	Request for specific Q information procedure	9.3.1	O	
5	Request for a new dummy procedure	9.3.2	O	
6	Basic setup procedure for single bearer basic connection of known service	10.2.4.2	C2m	
7	Normal setup procedure for single bearer advanced connection of known service	10.2.4.2	I	
8	Fast setup procedure for single bearer advanced connection of known service	10.2.4.2	I	
9	Normal setup procedure multi-bearer symmetric connection	10.2.4.3.1	I	
10	Fast setup procedure for multi-bearer symmetric connection	10.2.4.3.1	I	
11	Normal setup procedure for full asymmetric downlink connection	10.2.4.3.3	I	
12	Fast setup procedure for full asymmetric downlink connection	10.2.4.3.3	I	
13	Normal setup procedure for full asymmetric uplink connection	10.2.4.3.2	I	
14	Fast setup procedure for full asymmetric uplink connection	10.2.4.3.2	I	
15	Setup procedure for connection with unknown service	10.2.4.3	I	
16	Connection modification procedure	10.3	I	
17	Connection release procedure	10.4	I	
18	Basic single bearer setup procedure	10.5.1.1	C2m	
19	A_field advanced single bearer setup procedure	10.5.1.2	I	

(continued)

Q.36 Procedure support (concluded)

Procedures supported				
Item no.	Name of procedure	Ref.	Status	Support
20	B_field single bearer normal setup procedure	10.5.1.3.1	C2o	
21	B_field single bearer fast setup procedure	10.5.1.3.2	I	
22	Double simplex bearer indirect setup procedure	10.5.1.4	I	
23	Double simplex bearer direct setup procedure	10.5.1.4	I	
24	Duplex bearer handover procedure	10.6.2	I	
25	Double simplex bearer handover procedure	10.6.3	I	
26	Unacknowledged bearer release procedure	10.7.2.1	c2m	
27	Acknowledged bearer release procedure	10.7.2.2	I	
28	Fast bearer release procedure	10.7.2.3	I	
29	Q1 and Q2 bits setting procedure for C-channel data	10.8.1	C3m	
30	Q1 and Q2 bits setting procedure for IN and IP_error_detection data	10.8.1.3	I	
31	BCK and Q2 bits setting for IP_error_correction data in symmetric connection	10.8.2.4.1	I	
32	BCK and Acknowledgement (ACK) bit setting for IP_error_correction data in asymmetric connection	10.8.2.4.1	I	
33	Bearer replacement procedure	10.8.2.5.1	I	
34	Mac message jump procedure	10.8.2.5.2	I	
35	Unilateral jump procedure	10.8.2.5.3	I	
36	Idle_locked state entering procedure	11.3.2	N/A	
37	Idle_locked state maintaining procedure	11.3.3	N/A	
38	Duplex bearer channel selection procedure	11.4.1	I	
39	Double simplex bearer channel selection procedure	11.4.1	I	
40	Simplex bearer channel selection procedure	11.4.1	I	
41	Uplink connectionless channel selection	9.2.2	I	
42	Radio Fixed Part Identifier (RFPI) handshaking procedure	11.5.1	M	
43	PT frequency correction procedure	11.5.2.2	O	
44	MAC layer test message procedure	12.2	M	
45	Receiver scanning procedure	11.9	M	
46	PP paging procedure	9.1.3.2	M	
47	Channel list procedure	10.5.2	I	

Q.37 Parameters of channel selection procedure (duplex/double/simplex bearer)

Supported parameters						
Item no.	Parameter	Ref.	Status	Support	Values	
					Allowed	Supported
1	Lowest boundary of channel list	11.4.1	M		< = - 93 dBm	
2	Band resolution	11.4.1	M		6 dB	
3	RSSI variation between checking	11.4.1	M		< = 12 dB	

Annex D (normative): Service E2: Portable termination MAC PICS proforma

Notwithstanding the provisions of the copyright clause related to the text of this ETS, ETSI grants that users of this ETS may freely reproduce the PICS proforma in this annex so that it can be used for its intended purposes and may further publish the completed PICS.

D.1 Standardized symbols for the status column

The standardized symbols for the status column are as follows:

- m or M for mandatory;
- o or O for optional (Boolean);
- x or N/A for prohibited use;
- n/a, N/A or - (dash) for not applicable;
- cn or Cn for conditional on the implementation of feature n;
- i or I for out of scope (the capability is allowed to be implemented but is not called upon by the profile functionality).

Where reception of a message is marked as "O", this shall be understood to mean that correct understanding and processing of that message is optional.

C1: IF Encryption supported THEN C1=M

C2m: IF LRMS PTP (point to point) service supported THEN C2m=M ELSE I

C2o: IF LRMS PTP (point to point) service supported THEN C2o=O ELSE I

C3m: IF protected B-field available THEN C3m=M ELSE I

C3: IF protected B-field available THEN 1 else 0,1

C3o: IF protected B-field available THEN C3m=O ELSE I
 IC4: IF LRMS PTP (point-to-point) service supported AND protected B-field available THEN M ELSE I

C5m: IF LRMS PTM (point to multipoint) service supported THEN C5m = M ELSE I

C5o: IF LRMS PTM (point to multipoint) service supported THEN C5o = O ELSE I

C5h: IF LRMS PTM (point to multipoint) service supported THEN C5h = 1 ELSE 0, 1

C5l: IF LRMS PTM (point to multipoint) service supported THEN C5l = 0 ELSE 0, 1

C6: IF LRMS PTM (point to multipoint) service supported AND protected B-field available THEN M ELSE I

Except when stated otherwise, the reference column refers to the relevant subclause in ETS 300 175-3 [3].

D.2 Capabilities

D.2.1 Services

Q.9 Service support

Service supported				
Item no.	Name of service	Ref.	Status	Support
1	Type 1f IN_minimum delay	5.6.2.1	I	
2	Type 2f IN_normal delay	5.6.2.1	I	
3	Type 3f IP_error_detection	5.6.2.1	I	
4	Type 4f IP_error_correction	5.6.2.1	I	
5	Type 5 IN_normal delay	5.6.2.2	I	
6	Type 6 IP_error_detection	5.6.2.2	I	
7	Type 7f IP_error_correction	5.6.2.2	I	
8	Type 1h IN_minimum delay	5.6.2.1	I	
9	Type 2h IN_normal delay	5.6.2.1	I	
10	Type 3h IP_error_detection	5.6.2.1	I	
11	Type 4h IP_error_correction	5.6.2.1	I	
12	CS duplex	5.3.1.1	C2m	
13	CF duplex	5.3.1.1	C3m	
14	Downlink CLS only	5.7.2.1	C5m	
15	Downlink CLF + CLS	5.7.2.1	C6	
16	Downlink CLS + SIN	5.7.2.1	I	
17	Uplink CLF only	5.7.2.2	I	
18	Uplink CLS only	5.7.2.2	I	
19	Uplink without SDU	5.7.2.2	I	
20	GF simplex	5.3.1.3	I	
21	Fast paging	11.3.3.1	O	
22	Normal paging	11.3.3.1	M	
23	Low duty cycle paging	11.3.3.1	O	
24	System identities	11.3.2	M	
25	System information	11.3.2	M	
26	Encryption	6.2.3	C1	
27	Fast setup	11.3.3.2	I	

D.2.2 Protocol parameters

Q.11 Protocol parameters

Protocol parameters supported						
Item no.	Name	Ref.	Status	Support	Value	
					Allowed	Supported
1	N200	10.2	C2m		10	
2	N201	10.6	I			
3	N202	11.4	M		10	
4	N203	9.2	I			

D.2.3 Messages

Q.12 Messages in A_tail

Supported messages						
Item no.	Name	Ref.	Sending		Receipt	
			Status	Support	Status	Support
1	TA code: CT data packet number 0	7.1.2	C3m		C3m	
2	TA code: CT data packet number 1	7.1.2	C3m		C3m	
3	TA code: identities information on connectionless bearer	7.1.2	N/A		C2	
4	TA code: identities information	7.1.2	M		M	
5	TA code: multiframe sync. and system information	7.1.2	N/A		M	
6	TA code: main escape	7.1.2	X		X	
7	TA code: MAC layer control	7.1.2	M		M	
8	TA code: paging/first PT transmission	7.1.2	M		M	
9	BA code: U-type, IN, SIN or IP packet number 0	7.1.4	M		M	
10	BA code: U-type, IP error detect or IP packet number 1	7.1.4	I		I	
11	BA code: E-type, all CF or CLF, packet number 0	7.1.4	C3m		C3m	
12	BA code: E-type, all CF, packet number 1	7.1.4	C3m		C3m	
13	BA code: E-type, not all CF or CLF; CF packet number 0	7.1.4	C3m		C3m	
14	BA code: E-type, not all CF; CF packet number 1	7.1.4	C3m		C3m	
15	BA code: E-type, all MAC control	7.1.4	I		I	
16	BA code: no B_field	7.1.4	N/A		O	
17	NT information	7.2.2	M		M	
18	Static system information	7.2.3.2	N/A		M	
19	Extended RF carrier information	7.2.3.3	N/A		I	
20	Fixed part capabilities	7.2.3.4	N/A		M	
21	Extended fixed part capabilities	7.2.3.5	N/A		I	
22	SARI message	7.2.3.6	N/A		O	
23	Multi-frame number	7.2.3.7	N/A		C1	
24	Q-channel escape	7.2.3.8	N/A		I	
25	Zero length page indication	7.2.4.2.3	N/A		M	
26	Short page indication	7.2.4.2.3	N/A		M	
27	Full page indication	7.2.4.2.3	N/A		O	
28	Not the last 36 bits of a long page indication	7.2.4.2.3	N/A		I	
29	The first 36 bits of a long page indication	7.2.4.2.3	N/A		I	
30	The last 36 bits of a long page indication	7.2.4.2.3	N/A		I	
31	All of a long page indication	7.2.4.2.3	N/A		I	
32	PT header extend flag	7.2.4.2.2	N/A		M	
33	PT MAC information: fill	7.2.4.3.2	N/A		M	
34	PT MAC information: blind full slot	7.2.4.3.3	N/A		M	
35	PT MAC information: other bearer	7.2.4.3.4	N/A		O	
36	PT MAC information: recommended other bearer	7.2.4.3.4	N/A		O	
37	PT MAC information: good RFP bearer	7.2.4.3.4	N/A		O	
38	PT MAC information: dummy or C/L bearer position	7.2.4.3.4	N/A		M	
39	PT MAC information: RFP identity	7.2.4.3.5	N/A		I	

(continued)

Q.12 Messages in A_tail (continued)

Supported messages						
Item no.	Name	Ref.	Sending		Receipt	
			Status	Support	Status	Support
40	PT MAC information: dummy or C/L bearer marker	7.2.4.3.7	N/A		M	
41	PT MAC information: escape	7.2.4.3.6	N/A		I	
42	PT MAC information: bearer handover type 0000	7.2.4.3.8	N/A		I	
43	PT MAC information: bearer handover type 0001	7.2.4.3.8	N/A		I	
44	PT MAC information: bearer handover type 0010	7.2.4.3.8	N/A		I	
45	PT MAC information: bearer handover type 0011	7.2.4.3.8	N/A		I	
46	Basic access request	7.2.5.2	C2m		N/A	
47	Basic bearer handover request	7.2.5.2	I		N/A	
48	Basic connection handover request	7.2.5.2	I		N/A	
49	Basic unconfirmed access request	7.2.5.2	I		N/A	
50	Basic bearer confirm	7.2.5.2	N/A		C2m	
51	Basic wait	7.2.5.2.3	C2m		C2m	
52	Basic bearer release	7.2.5.2	C2m		C2m	
53	Advanced access request	7.2.5.3.2	I		I	
54	Advanced bearer handover request	7.2.5.3.3	I		I	
55	Advanced connection handover request	7.2.5.3.4	I		I	
56	Advanced bearer confirm	7.2.5.3.6	I		I	
57	Advanced unconfirmed access request	7.2.5.3.5	I		I	
58	Advanced wait	7.2.5.3.7	I		I	
59	Advanced attributes-T request	7.2.5.3.8	I		I	
60	Advanced attributes-T confirm	7.2.5.3.8	I		I	
61	Advanced bandwidth-T request	7.2.5.3.9	I		I	
62	Advanced bandwidth-T confirm	7.2.5.3.9	I		I	
63	Advanced channel list	7.2.5.3.10	I		I	
64	Advanced unconfirmed dummy	7.2.5.3.11	I		I	
65	Advanced unconfirmed handover	7.2.5.3.12	I		I	
66	Advanced bearer release	7.2.5.3.13	I		I	
67	Transmit on the specified slot/frequency test message	7.2.5.4.2	N/A		I	
68	Loopback B_field test message	7.2.5.4.3	N/A		I	
69	Defeat antenna diversity test message	7.2.5.4.4	N/A		I	
70	Force bearer handover test message	7.2.5.4.5	N/A		I	
71	Clear test mode test message	7.2.5.4.6	N/A		I	
72	Single bearer antenna switch QC message	7.2.5.5	O		O	
73	All bearer antenna switch QC message	7.2.5.5	O		O	
74	Bearer handover QC message	7.2.5.5	I		I	
75	Connection handover QC message	7.2.5.5	I		I	
76	Single bearer frequency control QC message	7.2.5.5	O		O	
77	All bearer frequency control QC message	7.2.5.5	O		O	
78	C/L single transmission with 1 CLF segment	7.2.5.6	C6		C6	
79	C/L single transmission with 2 CLF segments	7.2.5.6	C6		C6	
80	C/L single transmission with 3 CLF segments	7.2.5.6	C6		C6	
81	C/L single transmission with 4 CLF segments	7.2.5.6	C6		C6	
82	1st C/L half slot transmission with 1 CLF segment	7.2.5.6	I		I	
83	1st C/L full slot transmission with 4 CLF segment	7.2.5.6	C6		C6	
84	2nd C/L transmission with 1 CLF segment	7.2.5.6	C6		C6	
85	2nd C/L transmission with 2 CLF segment	7.2.5.6	C6		C6	
86	2nd C/L transmission with 3 CLF segment	7.2.5.6	C6		C6	
87	2nd C/L transmission with 4 CLF segment	7.2.5.6	C6		C6	
88	C/L single transmission without CLF segment	7.2.5.6	C3m		C3m	
89	1st C/L transmission without CLF segment (CLS service)	7.2.5.6	C3m		C3m	

(continued)

Q.12 Messages in A_tail (concluded)

Supported messages						
Item no.	Name	Ref.	Sending		Receipt	
			Status	Support	Status	Support
90	Change dummy position	7.2.5.6	O		N/A	
91	Extended system information	7.2.5.6	O		N/A	
92	Start encryption: request	7.2.5.7	C1		N/A	
93	Start encryption: confirm	7.2.5.7	N/A		C1	
94	Start encryption: grant	7.2.5.7	C1		N/A	
95	Stop encryption: request	7.2.5.7	C1		N/A	
96	Stop encryption: confirm	7.2.5.7	N/A		C1	
97	Stop encryption: grant	7.2.5.7	C1		N/A	
98	First transmission for B_field setup	7.2.5.8	I		I	
99	M-channel escape	7.2.5.9	I		I	

D.2.4 Message parameters

Q.14 Parameters of static system information message

Supported parameters						
Item no.	Parameter	Ref.	Status	Support	Values	
					Allowed	Supported
1	Normal-reverse	7.2.3.2.2	M		0 - 1	
2	Slot number	7.2.3.2.3	M		0 - 11	
3	Start position	7.2.3.2.4	M		0	
4	Escape	7.2.3.2.5	M		0 - 1	
5	Number of transceivers	7.2.3.2.6	M		0 - 3	
6	Extended RF carrier flag	7.2.3.2.7	M		0	
7	RF carriers available	7.2.3.2.8	M		1 - 1 023	
8	Spare	7.2.3.2.11	M		0	
9	Carrier number	7.2.3.2.10	M		0 - 9	
10	Spare	7.2.3.2.11	M		0	
11	Primary receiver scan number	7.2.3.2.12	M		0 - 9	

Q.15 Parameters of FP capabilities message

Fixed Part Capabilities						
Item no.	Parameter	Ref.	Status	Support	Values	
					Allowed	Supported
1	Extended FP information	7.2.3.4.2	M		0, 1	
2	Full slot	7.2.3.4.2	M		1	
3	Frequency control	7.2.3.4.2	M		0, 1	
4	Page repetition	7.2.3.4.2	M		0, 1	
5	C/O setup on dummy allowed	7.2.3.4.2	M		0,1	
6	C/L uplink	7.2.3.4.2	M		0, 1	
7	C/L downlink	7.2.3.4.2	M		C5h	
8	Basic A_field setup	7.2.3.4.2	M		C2	
9	Advanced A_field setup	7.2.3.4.2	M		0, 1	
10	B_field setup	7.2.3.4.2	M		0, 1	
11	CF messages	7.2.3.4.2	C3m		C3	
12	IN_minimum_delay	7.2.3.4.2	M		0, 1	
13	IN_normal_delay	7.2.3.4.2	M		0, 1	
14	IP_error_detection	7.2.3.4.2	M		0, 1	
15	IP_error_correction	7.2.3.4.2	M		0, 1	
16	Multibearer connection	7.2.3.4.2	M		0, 1	

D.2.5 Functions implemented

Q.34 Function implemented

Supported functions				
Item no.	Function name	Ref.	Status	Support
1	B_field data scrambling	6.2.4	C3m	
2	B_field data unscrambling	6.2.4	C3m	
3	R-CRC generation	6.2.5.2	M	
4	R-CRC checking	6.2.5.2	M	
5	X-CRC generation	6.2.5.4	C3m	
6	X-CRC checking	6.2.5.4	C3o	
7	Z-CRC generation	ETS 300 175-2 [2] 4.8	I	
8	Z-CRC checking	ETS 300 175-2 [2] 4.8	I	
9	D-MAP D80 field mapping	6.2.1.1	I	
10	D-MAP D32 field mapping	6.2.1.1	M	
11	D-MAP D08 field mapping	6.2.1.1	I	
12	D-MAP D00 field mapping	6.2.1.1	O	
13	A-MAP A_field mapping	6.2.1.2	M	
14	E/U-MUX E80 type multiplex	6.2.2.2	I	
15	E/U-MUX E32 type multiplex	6.2.2.2	C3m	
16	E/U-MUX E08 type multiplex	6.2.2.2	I	
17	E/U-MUX U80a type multiplex	6.2.2.2	I	
18	E/U-MUX U80b type multiplex	6.2.2.2	I	
19	E/U-MUX U32a type multiplex	6.2.2.2	C2m	
20	E/U-MUX U32b type multiplex	6.2.2.2	C3o	
21	E/U-MUX U08a type multiplex	6.2.2.2	I	
22	E/U-MUX U08b type multiplex	6.2.2.2	I	
23	C-MUX B_field full slot mode 0 multiplex	6.2.2.3.1	C3m	
24	C-MUX B_field full slot mode 1 multiplex	6.2.2.3.1	C3m	
25	C-MUX B_field full slot mode 2 multiplex	6.2.2.3.1	C3m	
26	C-MUX B_field full slot mode 3 multiplex	6.2.2.3.1	C3m	
27	C-MUX B_field full slot mode 4 multiplex	6.2.2.3.1	C3m	
28	C-MUX B_field half slot mode 0 multiplex	6.2.2.3.2	I	
29	C-MUX B_field half slot mode 1 multiplex	6.2.2.3.2	I	
30	T-MUX Tail multiplex	6.2.2.1.2	M	
31	Frequency correction function	11.5.2.2	O	

D.2.6 Timer support**Q.35 Timer support**

Timer supported						
Item no.	Name	Ref.	Status	Support	Values	
					Allowed	Supported
1	T200	10.2	C2m		3 seconds	
2	T201	11.5	C2m		5 seconds	
3	T202	10.6	I		3 seconds	
4	T203	10.6	N/A		16 frames	
5	T204	9.1	I		6 multiframe	
6	T205	9.1	M		10 seconds	
7	T206	11.2	I		10 frames	
8	T207	11.3	M		5 seconds	
9	T208	11.3	M		20 seconds	
10	T209	11.4	M		30 seconds	
11	T210	11.4	C2m		2 seconds	
12	T211	11.3	I		3 seconds	
13	T212	10.5	I		20 frames	
14	T213	10.7	I		20 frames	
15	T214	9.2	I		20 frames	
16	T215	9.2	I		6 multiframe	

D.2.7 Procedure support**Q.36 Procedure support**

Procedures supported				
Item no.	Name of procedure	Ref.	Status	Support
1	Downlink connectionless procedure	9.1.2	C5m	
2	Downlink broadcast procedure	9.1.1	M	
3	Uplink connectionless procedure	9.2.3	I	
4	Request for specific Q information procedure	9.3.1	O	
5	Request for a new dummy procedure	9.3.2	O	
6	Basic setup procedure for single bearer basic connection of known service	10.2.4.2	C2m	
7	Normal setup procedure for single bearer advanced connection of known service	10.2.4.2	I	
8	Fast setup procedure for single bearer advanced connection of known service	10.2.4.2	I	
9	Normal setup procedure for multi-bearer symmetric connection	10.2.4.3.1	I	
10	Fast setup procedure for multi-bearer symmetric connection	10.2.4.3.1	I	
11	Normal setup procedure for full asymmetric downlink connection	10.2.4.3.3	I	
12	Fast setup procedure for full asymmetric downlink connection	10.2.4.3.3	I	
13	Normal setup procedure for full asymmetric uplink connection	10.2.4.3.2	I	
14	Fast setup procedure for full asymmetric uplink connection	10.2.4.3.2	I	
15	Setup procedure for connection with unknown service	10.2.4.3	I	
16	Connection modification procedure	10.3	I	
17	Connection release procedure	10.4	I	
18	Basic single bearer setup procedure	10.5.1.1	C2m	
19	A ₁ field advanced single bearer setup procedure	10.5.1.2	I	

(continued)

Q.36 Procedure support (concluded)

Item no.	Name of procedure	Ref.	Status	Support
20	B_field single bearer normal setup procedure	10.5.1.3.1	C2o	
21	B_field single bearer fast setup procedure	10.5.1.3.2	I	
22	Double simplex bearer indirect setup procedure	10.5.1.4	I	
23	Double simplex bearer direct setup procedure	10.5.1.4	I	
24	Duplex bearer handover procedure	10.6.2	I	
25	Double simplex bearer handover procedure	10.6.3	I	
26	Unacknowledged bearer release procedure	10.7.2.1	C2m	
27	Acknowledged bearer release procedure	10.7.2.2	I	
28	Fast bearer release procedure	10.7.2.3	I	
29	Q1 and Q2 bits setting procedure for C-channel data	10.8.1	C3m	
30	Q1 and Q2 bits setting procedure for IN and IP_error_detection data	10.8.1.3	I	
31	BCK and Q2 bits setting for IP_error_correction data in symmetric connection	10.8.2.4.1	I	
32	BCK and ACK bit setting for IP_error_correction data in asymmetric connection	10.8.2.4.1	I	
33	Bearer replacement procedure	10.8.2.5.1	I	
34	Mac message jump procedure	10.8.2.5.2	I	
35	Unilateral jump procedure	10.8.2.5.3	I	
36	Idle_locked state entering procedure	11.3.2	N/A	
37	Idle_locked state maintaining procedure	11.3.3	N/A	
38	Duplex bearer channel selection procedure	11.4.1	I	
39	Double simplex bearer channel selection procedure	11.4.1	I	
40	Simplex bearer channel selection procedure	11.4.1	I	
41	Uplink connectionless channel selection	9.2.2	C2	
42	RFPI handshaking procedure	11.5.1	M	
43	PT frequency correction procedure	11.5.2.2	O	
44	MAC layer test message procedure	12.2	I	
45	Receiver scanning procedure	11.9	M	
46	PP paging procedure	9.1.3.2	M	
47	Channel list procedure	10.5.2	I	

Q.37 Parameters of channel selection procedure (duplex/double/simplex bearer)

Supported parameters						
Item no.	Parameter	Ref.	Status	Support	Values	
					Allowed	Supported
1	Lowest boundary of channel list	11.4.1	M		< = - 93 dBm	
2	Band resolution	11.4.1	M		6 dB	
3	RSSI variation between checking	11.4.1	M		< = 12 dB	

Annex E (normative): Service E2: Fixed termination DLC PICS proforma

Notwithstanding the provisions of the copyright clause related to the text of this ETS, ETSI grants that users of this ETS may freely reproduce the PICS proforma in this annex so that it can be used for its intended purposes and may further publish the completed PICS.

E.1 Standardized symbols for the status column

The standardized symbols for the status column are as follows:

- m or M for mandatory (the capability is required to be implemented);
- o or O for optional (Boolean) (the capability may be implemented);
- x or X for prohibited or excluded use (the capability may not be used in a given context);
- n/a, N/A or - (dash) for not applicable (the capability is not allowed because the underlying DECT layers (service provider) cannot handle it or the requirement belongs to an application i.e. does not belong to the data link control layer);
- c or C for conditional (the capability depends on the selection of other optional or/and conditional items).
- i or I for out of scope (the capability is allowed to be implemented but is not called upon by the profile functionality).

If appropriate, a "C" followed by an integer is placed in the status column, providing a reference to a conditional status expression defined elsewhere in the PICS proforma. The following conditions are applicable throughout the entire document:

Condition identifier	Condition definition
C1	IF Q.9/2 THEN M ELSE I (only used for values)
C1m	IF Q.9/2 THEN M ELSE IX
C1o	IF Q.9/2 THEN O ELSE IX
C2	IF Q.9/3 THEN M ELSE I (only used for values)
C2m	IF Q.9/3 THEN M ELSE I
C2o	IF Q.9/3 THEN O ELSE I
C3	IF Q.40 THEN M ELSE I
C4	IF applied for speech transmission THEN M
C5	The definitive specification of this service is for further study
C6	IF Q.28/1 THEN O ELSE I
C7	IF Q.18/5 THEN O ELSE I
8m	IF Q.32/5 THEN M ELSE I
C9m	IF Q.9/1 THEN M ELSE I
C9o	IF Q.9/1 THEN O ELSE I
C10m	IF LRMS_PTP (point to point) service supported THEN M ELSE I
C10o	IF LRMS_PTP (point to point) service supported THEN O ELSE I
C11	IF LRMS_PTM (point to multipoint) service supported THEN M ELSE I

E.2 Capabilities

E.2.1 Major capabilities

E.2.1.1 C-plane capabilities

E.2.1.1.1 C-plane services

Q.9 C-plane data link services

Supported services				
Item No	C-plane services	Ref.	Status	Support
1	Class U service	5.1	C11	
2	Class A service	5.1	C10m	
3	Class B service	5.1	C10o	

Q.10 C-plane broadcast service

Supported services				
Item No	C-plane services	Ref.	Status	Support
1	Broadcast service	5.2, 9.4	M	

E.2.1.1.2 C-plane procedures

E.2.1.1.2.1 Point to point acknowledged operation

Q.11 Class A procedures

Supported procedures				
Item No	Operation - General procedures	Ref.	Status	Support
1	Class A link establishment	9.2.3.1	C1m	
2	Class A acknowledged information transfer	9.2.3.2	C1m	
3	Class A link release	9.2.3.7	C1m	
4	Class A link re-establishment	9.2.3.8	C1m	
5	Class A connection handover	9.2.7.3.1	C1o	

Q.12 Class A features

Supported features				
Item No	Operation - General feature	Ref.	Status	Support
1	Segmentation of NWK information	5.1.1, 7.7	C1m	
2	CS channel fragmentation and recombination	6.1.2, 6.1.3, 6.1.4, 6.1.4.2	C1m	
3	CF channel fragmentation and recombination	6.1.2, 6.1.3, 6.1.4, 6.1.4.1	C1o	

Q.13 Class A parameter values

Supported parameter values				
Item No	Parameter	Ref.	Status	Support
1	Fixed window size of 1 ?	9.2.3.2, 7.5.2.2	C1m	
2	Modulo 2 ?	9.2.3.2, 7.5.2.1	C1m	

Q.14 Class B procedures

Supported procedures				
Item No	Operation - General procedures	Ref.	Status	Support
1	Class B multiple frame establishment	9.2.4	C2m	
2	Class B information transfer	9.2.5	C2m	
3	Class B link release	9.2.6	C2m	
4	Class B link suspension and resumption	9.2.7	C2m	
5	Class B connection handover	9.2.7.3.2	C2o	

Q.15 Class B features

Supported features				
Item No	Operation - General feature	Ref.	Status	Support
1	Segmentation of NWK information	5.1.1, 7.7	C2m	
2	CS channel fragmentation and recombination	6.1.2, 6.1.3, 6.1.4, 6.1.4.2	C2m	
3	CF channel fragmentation and recombination	6.1.2, 6.1.3, 6.1.4, 6.1.4.1	C2o	

Q.16 Class B parameter values

Supported parameter values				
Item No	Parameter	Ref.	Status	Support
1	Fixed window size of 3 ?	9.2.4.2, 7.5.2.2	C2m	
2	Modulo 1 in ULI state ?	9.2.4.2	C2m	
3	Modulo 8 in ASM state ?	9.2.4.2, 7.5.2.1	C2m	

E.2.1.1.2.2 Unacknowledged operation**Q.17 Class U procedures**

Supported procedures				
Item No	Operation - General procedures	Ref.	Status	Support
1	Class U link establishment	9.3.2	C9m	
2	Class U information transfer	9.3.3	C9m	
3	Class U link release	9.3.4	C9m	

E.2.1.1.2.3 Broadcast operation**Q.17.1 Broadcast procedures**

Supported procedures				
Item No	Operation - General procedures	Ref.	Status	Support
1	Normal operation	9.4.1	M	
2	Expedited operation	9.4.2	O	

E.2.1.2 Management procedures**Q.32 Management procedures**

Supported procedures				
Item No	General procedures	Ref.	Status	Support
1	MAC connection management	10.2	M	
2	DLC C-plane management	10.3	M	
3	DLC U-plane management	10.4	I	
4	Connection handover management	10.5	C10o	
5	Connection ciphering management	10.6	C8	

Q.33 MAC connection management procedures

Supported procedures				
Item No	Procedures	Ref.	Status	Support
1	MAC connection set-up	10.2.1	M	
2	MAC connection release	10.2.2	M	
3	MAC connection modification	10.2.3	I	
4	MAC connection identification	10.2.4	M	
5	Selection of logical channels (CS or CF)	10.2.5	M	

Q.34 DLC C-plane management procedures

Supported procedures				
Item No	Procedures	Ref.	Status	Support
1	Provision of link signature	10.3.1	M	
2	Routeing of connection oriented links	10.3.2	C10m	
3	Routeing of connectionless links	10.3.3	C11	

Q.36 Connection ciphering management procedures

Supported procedures				
Item No	Procedures	Ref.	Status	Support
1	Providing a key to the MAC layer	10.6.1	C8	
2	Starting and stopping the ciphering	10.6.2	C8	
3	Connection handover	10.6.3	C8	

E.2.2 Protocol Data Units (PDUs)**E.2.2.1 C-plane PDUs****E.2.2.1.1 C-plane frame structure****Q.37 Frame structures**

Supported frames structures								
Item No	Frame Structures	Ref.	Sending			Receiving		
			Status	Support		Status	Support	
				Yes	No		Yes	No
1	Frame structure of format type FA.	6.1	M			M		
2	Broadcast service frame structure	6.2	M			N/A		

Q.38 Frame format type FA

Item No	Frame elements	Ref.	Sending			Receiving		
			Status	Support		Status	Support	
				Yes	No		Yes	No
1	Address field	6.1	M			M		
2	Control field	6.1	M			M		
3	Length indicator field	6.1	C3			C3		
4	Information field	6.1	C3			C3		
5	Fill field	6.1	C3			C3		
6	Checksum field	6.1	M			M		

Q.38.1 Broadcast service frame structure

Supported frames structures								
Item No	Frame elements	Ref.	Sending			Receiving		
			Status	Support		Status	Support	
				Yes	No		Yes	No
1	Short frame format (3 octets)	6.2.1	M			N/A		
2	Long frame format (5 octets)	6.2.1	M			N/A		

E.2.2.1.2 C-plane messages

Q.39 Message support

Supported messages								
Item No	Message elements	Ref.	Sending (P to F)			Receiving (F to P)		
			Status	Support		Status	Support	
				Yes	No		Yes	No
1	I-command	7.11	M			M		
2	RR-command/response	7.11	M			M		
3	RNR-command/response	7.11	C2m			C2m		
4	REJ-command/response	7.11	C2m			C2m		
5	SABM-command	7.11	C2m			C2m		
6	DM-response	7.11	C2m			C2m		
7	UI-command	7.11	M			M		
8	DISC-command	7.11	C2m			C2m		
9	UA-response	7.11	C2m			C2m		

Q.40 I-command (numbered Information)

Item no.	Name of information element and field element	Ref.	Sending				Receipt			
			Status	Supp.	Value		Status	Supp.	Value	
					Allowed	Supported			Allowed	Supported
1	Address field	7.2	M				M			
1.1	RES	7.3.1	M		1		M		1	
1.2	C/R	7.3.2	M		1		M		0	
1,3	SAPI	7.3.3	M		0		M		0	
1.4	Logical Link Number (LLN)	7.3.5	M		1 C1 2-6 C2		M		1 C1 2-6 C2	
1.5	New Link Flag (NLF)	7.3.4, 9.2.2.1	M		0-1		M		0-1	
2	Control field	7.4	M				M			
2.1	N(S)	7.5.2.4	M		0-1 C1 0-7 C2		M		0-1 C1 0-7 C2	
2.2	P	7.5.1 9.2.1	M		0 C1 0-1 C2		M		0 C1 0-1 C2	
2.3	N(R)	7.5.2.6	M		0-1 C1 0-7 C2		M		0-1 C1 0-7 C2	
3	Length indicator field	7.6	M				M			
4	Information field	7.8	M				M			
5	Checksum field	7.10	M				M			

Q.41 RR-command/response (Receive Ready)

Item no.	Name of information element and field element	Ref.	Sending				Receipt			
			Status	Supp.	Value		Status	Supp.	Value	
					Allowed	Supported			Allowed	Supported
1	Address field	7.2	M				M			
1.1	RES	7.3.1	M		1		M		1	
1.2	C/R	7.3.2	M		0-1		M		0-1	
1,3	SAPI	7.3.3	M		0		M		0	
1.4	LLN	7.3.5	M		1 C1 2-7 C2		M		1 C1 2-7 C2	
1.5	NLF	7.3.4, 9.2.2.1	M		0-1		M		0-1	
2	Control field	7.4	M				M			
2.1	S (Supervisory function bits)	7.5.2.4	M		0		M		0	
2.2	P/F	7.5.1, 9.2.1	M		0 C1 0-1 C2		M		0 C1 0-1 C2	
2.3	N(R)	7.5.2.6	M		0-1 C1 0-7 C2		M		0-1 C1 0-7 C2	
3	Checksum field	7.10	M				M			

Q.42 RNR-command/response (Receive Not Ready)

Item no.	Name of information element and field element	Ref.	Sending				Receipt			
			Status	Supp.	Value		Status	Supp.	Value	
					Allowed	Supported			Allowed	Supported
1	Address field	7.2	M				M			
1.1	RES	7.3.1	M		1		M		1	
1.2	C/R	7.3.2	M		0-1		M		0-1	
1,3	SAPI	7.3.3	M		0		M		0	
1.4	LLN	7.3.5	M		2-6		M		2-6	
1.5	NLF	7.3.4, 9.2.2.1	M		0-1		M		0-1	
2	Control field	7.4	M				M			
2.1	S (Supervisory function bits)	7.5.2.4	M		1		M		1	
2.2	P/F	7.5.1, 9.2.1	M		0-1		M		0-1	
2.3	N(R)	7.5.2.6	M		0-7		M		0-7	
3	Checksum field	7.10	M				M			

Q.43 REJ-command/response (Reject)

Item no.	Name of information element and field element	Ref.	Sending (P to F)				Receipt (F to P)			
			Status	Supp.	Value		Status	Supp.	Value	
					Allowed	Supported			Allowed	Supported
1	Address field	7.2	M				M			
1.1	RES	7.3.1	M		1		M		1	
1.2	C/R	7.3.2	M		0-1		M		0-1	
1,3	SAPI	7.3.3	M		0		M		0	
1.4	LLN	7.3.5	M		1 C1 2-7 C2		M		1 C1 2-7 C2	
1.5	NLF	7.3.4, 9.2.2.1	M		0-1		M		0-1	
2	Control field	7.4	M				M			
2.1	S (Supervisory function bits)	7.5.2.4	M		2		M		2	
2.2	P/F	7.5.1, 9.2.1	M		0 C1 0-1 C2		M		0 C1 0-1 C2	
2.3	N(R)	7.5.2.6	M		0-1 C1 0-7 C2		M		0-1 C1 0-7 C2	
3	Checksum field	7.10	M				M			

Q.44 SABM-command (Set Asynchronous Balanced Mode)

Item no.	Name of information element and field element	Ref.	Sending (P to F)				Receipt (F to P)			
			Status	Supp.	Value		Status	Supp.	Value	
					Allowed	Supported			Allowed	Supported
1	Address field	7.2	M				M			
1.1	RES	7.3.1	M		1		M		1	
1.2	C/R	7.3.2	M		1		M		0	
1,3	SAPI	7.3.3	M		0		M		0	
1.4	LLN	7.3.5	M		1 C1 2-7 C2		M		1 C1 2-7 C2	
1.5	NLF	7.3.4, 9.2.2.1	M		0-1		M		0-1	
2	Control field	7.4	M				M			
2.1	U (Unnumbered function bits) length: 5 BIT (2+3)	7.5.2.4	M		7		M		7	
2.2	P	7.5.1, 9.2.1	M		0 C1 1 C2		M		0 C1 1 C2	
3	Checksum field	7.10	M				M			

Q.45 DM-response (Disconnect Mode)

Item no.	Name of information element and field element	Ref.	Sending (P to F)				Receipt (F to P)			
			Status	Supp.	Value		Status	Supp.	Value	
					Allowed	Supported			Allowed	Supported
1	Address field	7.2	M				M			
1.1	RES	7.3.1	M		1		M		1	
1.2	C/R	7.3.2	M		0		M		1	
1,3	SAPI	7.3.3	M		0		M		0	
1.4	LLN	7.3.5	M		1 C1 2-7 C2		M		1 C1 2-7 C2	
1.5	NLF	7.3.4, 9.2.2.1	M		0-1		M		0-1	
2	Control field	7.4	M				M			
2.1	U (Unnumbered function bits) length: 5 BIT (2+3)	7.5.2.4	M		3		M		3	
2.2	F	7.5.1, 9.2.1	M		0 C1 0-1 C2		M		0 C1 0-1 C2	
3	Checksum field	7.10	M				M			

Q.46 UI-command (Unnumbered Information)

Item no.	Name of information element and field element	Ref.	Sending				Receipt			
			Status	Supp.	Value		Status	Supp.	Value	
					Allowed	Supported			Allowed	Supported
1	Address field	7.2	M				M			
1.1	RES	7.3.1	M		1		M		1	
1.2	C/R	7.3.2	M		1		M		0	
1,3	SAPI	7.3.3	M		0		M		0	
1.4	LLN	7.3.5	M		1 C1 2-7 C2		M		1 C1 2-7 C2	
1.5	NLF	7.3.4, 9.2.2.1	M		0-1		M		0-1	
2	Control field	7.4	M				M			
2.1	U (Unnumbered function bits) length: 5 BIT (2+3)	7.5.2.4	M		0		M		0	
2.2	P	7.5.1, 9.2.1	M		0 C1 0-1 C2		M		0 C1 0-1 C2	
3	Checksum field	7.10	M				M			

Q.47 DISC-command (Disconnect)

Item no.	Name of information element and field element	Ref.	Sending (P to F)				Receipt (F to P)			
			Status	Supp.	Value		Status	Supp.	Value	
					Allowed	Supported			Allowed	Supported
1	Address field	7.2	M				M			
1.1	RES	7.3.1	M		1		M		1	
1.2	C/R	7.3.2	M		1		M		0	
1,3	SAPI	7.3.3	M		0		M		0	
1.4	LLN	7.3.5	M		1 C1 2-7 C2		M		1 C1 2-7 C2	
1.5	NLF	7.3.4, 9.2.2.1	M		0-1		M		0-1	
2	Control field	7.4	M				M			
2.1	U (Unnumbered function bits) length: 5 BIT (2+3)	7.5.2.4	M		8		M		8	
2.2	P	7.5.1, 9.2.1	M		0 C1 0-1 C2		M		0 C1 0-1 C2	
3	Checksum field	7.10	M				M			

Q.48 UA response (Unnumbered ACK)

Item no.	Name of information element and field element	Ref.	Sending (P to F)				Receipt (F to P)			
			Status	Supp.	Value		Status	Supp.	Value	
					Allowed	Supported			Allowed	Supported
1	Address field	7.2	M				M			
1.1	RES	7.3.1	M		1		M		1	
1.2	C/R	7.3.2	M		0		M		1	
1,3	SAPI	7.3.3	M		0		M		0	
1.4	LLN	7.3.5	M		1 C1 2-7 C2		M		1 C1 2-7 C2	
1.5	NLF	7.3.4, 9.2.2.1	M		0-1		M		0-1	
2	Control field	7.4	M				M			
2.1	U (Unnumbered function bits) length: 5 BIT (2+3)	7.5.2.4	M		12		M		12	
2.2	F	7.5.1, 9.2.1	M		0 C1 0-1C2		M		0 C1 0-1C2	
3	Checksum field	7.10	M				M			

E.2.3 Timers

E.2.3.1 C-plane timers

Q.61 C-plane timers

Supported timers						
Item no.	Timer	Ref.	Status	Supp.	Value	
					Allowed	Supported
1	DL.00	A.1	M		2 s	
2	DL.01	A.1	M		2 s	
3	DL.02	A.1	M		2 s	
4	DL.03	A.1	M		2 s	
5	DL.04 (CF routed frames)	A.1	M		1 s	
6	DL.04 (CS routed frames)	A.1	M		2 s	
7	DL.05	A.1	M		10 s	
8	DL.06	A.1	M		4 s	
7	DL.07	A.1	M		2 s	

E.2.4 Protocol error handling

E.2.4.1 C-plane protocol error handling

Q.63 General error handling

Supported procedures				
Item No	Operation - General procedures	Ref.	Status	Support
1	Invalid frames are discarded	9.2.9.1	M	

Q.64 Class A error recovery

Supported procedures				
Item No	Operation - General procedures	Ref.	Status	Support
1	Waiting for acknowledgement, timer DL.04 expiry	9.2.3.6	C1m	

Q.65 Class B error handling and recovery

Supported procedures				
Item No	Operation - General procedures	Ref.	Status	Support
1	N(S) sequence error	9.2.9.2.1	C2m	
2	N(R) sequence error	9.2.9.2.2	C2m	
3	Timer recovery condition	9.2.9.2.3	C2m	

Q.66 Unknown or invalid frames (which provoke error handling as requested in Q.63)

Supported frames				
Item No	Frame types	Ref.	Status	Support
1	Unknown frames	9.2.9.1, 7.11	M	
2	Invalid frames	6.1.5	M	

Annex F (normative): Service E2: Portable termination DLC PICS proforma

Notwithstanding the provisions of the copyright clause related to the text of this ETS, ETSI grants that users of this ETS may freely reproduce the PICS proforma in this annex so that it can be used for its intended purposes and may further publish the completed PICS.

F.1 Standardized symbols for the status column

The standardized symbols for the status column are as follows:

- m or M for mandatory (the capability is required to be implemented);
- o or O for optional (Boolean) (the capability may be implemented);
- x or X for prohibited or excluded use (the capability may not be used in a given context);
- n/a, N/A or - (dash) for not applicable (the capability is not allowed because the underlying DECT layers (service provider) cannot handle it or the requirement belongs to an application i.e. does not belong to the data link control layer);
- c or C for conditional (the capability depends on the selection of other optional or/and conditional items).
- i or I for out of scope (the capability is allowed to be implemented but is not called upon by the profile functionality).

If appropriate, a "C" followed by an integer is placed in the status column, providing a reference to a conditional status expression defined elsewhere in the PICS proforma. The following conditions are applicable throughout the entire document:

Condition identifier	Condition definition
C1	IF Q.9/2 THEN M ELSE I (only used for values)
C1m	IF Q.9/2 THEN M ELSE IX
C1o	IF Q.9/2 THEN O ELSE IX
C2	IF Q.9/3 THEN M ELSE I (only used for values)
C2m	IF Q.9/3 THEN M ELSE I
C2o	IF Q.9/3 THEN O ELSE I
C3	IF Q.40 THEN M ELSE I
C4	IF applied for speech transmission THEN M
C5	The definitive specification of this service is for further study
C6	IF Q.28/1 THEN O ELSE I
C7	IF Q.18/5 THEN O ELSE I
8m	IF Q.32/5 THEN M ELSE I
C9m	IF Q.9/1 THEN M ELSE I
C9o	IF Q.9/1 THEN O ELSE I
C10m	IF LRMS_PTP (point to point) service supported THEN M ELSE I
C10o	IF LRMS_PTP (point to point) service supported THEN O ELSE I
C11	IF LRMS_PTM (point to multipoint) service supported THEN M ELSE I

F.2 Capabilities

F.2.1 Major capabilities

F.2.1.1 C-plane capabilities

F.2.1.1.1 C-plane services

Q.9 C-plane data link services

Supported services				
Item No	C-plane services	Ref.	Status	Support
1	Class U service	5.1	C11	
2	Class A service	5.1	C10m	
3	Class B service	5.1	C10o	

Q.10 C-plane broadcast service

Supported services				
Item No	C-plane services	Ref.	Status	Support
1	Broadcast service	5.2, 9.4	M	

F.2.1.1.2 C-plane procedures

F.2.1.1.2.1 Point to point acknowledged operation

Q.11 Class A procedures

Supported procedures				
Item No	Operation - General procedures	Ref.	Status	Support
1	Class A link establishment	9.2.3.1	C1m	
2	Class A acknowledged information transfer	9.2.3.2	C1m	
3	Class A link release	9.2.3.7	C1m	
4	Class A link re-establishment	9.2.3.8	C1m	
5	Class A connection handover	9.2.7.3.1	C1o	

Q.12 Class A features

Supported features				
Item No	Operation - General feature	Ref.	Status	Support
1	Segmentation of NWK information	5.1.1, 7.7	C1m	
2	CS channel fragmentation and recombination	6.1.2, 6.1.3, 6.1.4, 6.1.4.2	C1m	
3	CF channel fragmentation and recombination	6.1.2, 6.1.3, 6.1.4, 6.1.4.1	C1o	

Q.13 Class A parameter values

Supported parameter values				
Item No	Parameter	Ref.	Status	Support
1	Fixed window size of 1 ?	9.2.3.2, 7.5.2.2	C1m	
2	Modulo 2 ?	9.2.3.2, 7.5.2.1	C1m	

Q.14 Class B procedures

Supported procedures				
Item No	Operation - General procedures	Ref.	Status	Support
1	Class B multiple frame establishment	9.2.4	C2m	
2	Class B information transfer	9.2.5	C2m	
3	Class B link release	9.2.6	C2m	
4	Class B link suspension and resumption	9.2.7	C2m	
5	Class B connection handover	9.2.7.3.2	C2o	

Q.15 Class B features

Supported features				
Item No	Operation - General feature	Ref.	Status	Support
1	Segmentation of NWK information	5.1.1, 7.7	C2m	
2	CS channel fragmentation and recombination	6.1.2, 6.1.3, 6.1.4, 6.1.4.2	C2m	
3	CF channel fragmentation and recombination	6.1.2, 6.1.3, 6.1.4, 6.1.4.1	C2o	

Q.16 Class B parameter values

Supported parameter values				
Item No	Parameter	Ref.	Status	Support
1	Fixed window size of 3 ?	9.2.4.2, 7.5.2.2	C2m	
2	Modulo 1 in ULI state ?	9.2.4.2	C2m	
3	Modulo 8 in ASM state ?	9.2.4.2, 7.5.2.1	C2m	

F.2.1.1.2.2 Unacknowledged operation

Q.17 Class U procedures

Supported procedures				
Item No	Operation - General procedures	Ref.	Status	Support
1	Class U link establishment	9.3.2	C9m	
2	Class U information transfer	9.3.3	C9m	
3	Class U link release	9.3.4	C9m	

F.2.1.1.2.3 Broadcast operation

Q.17.1 Broadcast procedures

Supported procedures				
Item No	Operation - General procedures	Ref.	Status	Support
1	Normal operation	9.4.1	M	
2	Expedited operation	9.4.2	O	

F.2.1.2 Management procedures

Q.32 Management procedures

Supported procedures				
Item No	General procedures	Ref.	Status	Support
1	MAC connection management	10.2	M	
2	DLC C-plane management	10.3	M	
3	DLC U-plane management	10.4	I	
4	Connection handover management	10.5	C10o	
5	Connection ciphering management	10.6	C8	

Q.33 MAC connection management procedures

Supported procedures				
Item No	Procedures	Ref.	Status	Support
1	MAC connection set-up	10.2.1	M	
2	MAC connection release	10.2.2	M	
3	MAC connection modification	10.2.3	I	
4	MAC connection identification	10.2.4	M	
5	Selection of logical channels (CS or CF)	10.2.5	M	

Q.34 DLC C-plane management procedures

Supported procedures				
Item No	Procedures	Ref.	Status	Support
1	Provision of link signature	10.3.1	M	
2	Routeing of connection oriented links	10.3.2	C10m	
3	Routeing of connectionless links	10.3.3	C11	

Q.36 Connection ciphering management procedures

Supported procedures				
Item No	Procedures	Ref.	Status	Support
1	Providing a key to the MAC layer	10.6.1	C8	
2	Starting and stopping the ciphering	10.6.2	C8	
3	Connection handover	10.6.3	C8	

F.2.2 PDUs

F.2.2.1 C-plane PDUs

F.2.2.1.1 C-plane frame structure

Q.37 Frame structures

Supported messages								
Item No	Frame Structures	Ref.	Sending			Receiving		
			Status	Support		Status	Support	
				Yes	No		Yes	No
1	Frame structure of format type FA.	6.1	M			M		
2	Broadcast service frame structure	6.2	N/A			M		

Q.38 Frame format type FA

Item No	Frame elements	Ref.	Sending			Receiving		
			Status	Support		Status	Support	
				Yes	No		Yes	No
1	Address field	6.1	M			M		
2	Control field	6.1	M			M		
3	Length indicator field	6.1	C3			C3		
4	Information field	6.1	C3			C3		
5	Fill field	6.1	C3			C3		
6	Checksum field	6.1	M			M		

Q.38.1 Broadcast service frame structure

Supported frame structures								
Item No	Frame elements	Ref.	Sending			Receiving		
			Status	Support		Status	Support	
				Yes	No		Yes	No
1	Short frame format (3 octets)	6.2.1	N/A			M		
2	Long frame format (5 octets)	6.2.1	N/A			O		

F.2.2.1.2 C-plane messages

Q.39 Message support

Supported messages								
Item No	Message elements	Ref.	Sending			Receiving		
			Status	Support		Status	Support	
				Yes	No		Yes	No
1	I-command	7.11	M			M		
2	RR-command/response	7.11	M			M		
3	RNR-command/response	7.11	C2m			C2m		
4	REJ-command/response	7.11	C2m			C2m		
5	SABM-command	7.11	C2m			C2m		
6	DM-response	7.11	C2m			C2m		
7	UI-command	7.11	M			M		
8	DISC-command	7.11	C2m			C2m		
9	UA-response	7.11	C2m			C2m		

Q.40 I-command (numbered Information)

Item no.	Name of information element and field element	Ref.	Sending				Receipt			
			Status	Supp.	Value		Status	Supp.	Value	
					Allowed	Supported			Allowed	Supported
1	Address field	7.2	M				M			
1.1	RES	7.3.1	M		1		M		1	
1.2	C/R	7.3.2	M		1		M		0	
1,3	SAPI	7.3.3	M		0		M		0	
1.4	LLN	7.3.5	M		1 C1 2-6 C2		M		1 C1 2-6 C2	
1.5	NLF	7.3.4, 9.2.2.1	M		0-1		M		0-1	
2	Control field	7.4	M				M			
2.1	N(S)	7.5.2.4	M		0-1 C1 0-7 C2		M		0-1 C1 0-7 C2	
2.2	P	7.5.1 9.2.1	M		0 C1 0-1 C2		M		0 C1 0-1 C2	
2.3	N(R)	7.5.2.6	M		0-1 C1 0-7 C2		M		0-1 C1 0-7 C2	
3	Length indicator field	7.6	M				M			
4	Information field	7.8	M				M			
5	Checksum field	7.10	M				M			

Q.41 RR-command/response (Receive Ready)

Item no.	Name of information element and field element	Ref.	Sending				Receipt			
			Status	Supp.	Value		Status	Supp.	Value	
					Allowed	Supported			Allowed	Supported
1	Address field	7.2	M				M			
1.1	RES	7.3.1	M		1		M		1	
1.2	C/R	7.3.2	M		0-1		M		0-1	
1,3	SAPI	7.3.3	M		0		M		0	
1.4	LLN	7.3.5	M		1 C1 2-7 C2		M		1 C1 2-7 C2	
1.5	NLF	7.3.4, 9.2.2.1	M		0-1		M		0-1	
2	Control field	7.4	M				M			
2.1	S (Supervisory function bits)	7.5.2.4	M		0		M		0	
2.2	P/F	7.5.1, 9.2.1	M		0 C1 0-1 C2		M		0 C1 0-1 C2	
2.3	N(R)	7.5.2.6	M		0-1 C1 0-7 C2		M		0-1 C1 0-7 C2	
3	Checksum field	7.10	M				M			

Q.42 RNR-command/response (Receive Not Ready)

Item no.	Name of information element and field element	Ref.	Sending				Receipt			
			Status	Supp.	Value		Status	Supp.	Value	
					Allowed	Supported			Allowed	Supported
1	Address field	7.2	M				M			
1.1	RES	7.3.1	M		1		M		1	
1.2	C/R	7.3.2	M		0-1		M		0-1	
1,3	SAPI	7.3.3	M		0		M		0	
1.4	LLN	7.3.5	M		2-6		M		2-6	
1.5	NLF	7.3.4, 9.2.2.1	M		0-1		M		0-1	
2	Control field	7.4	M				M			
2.1	S (Supervisory function bits)	7.5.2.4	M		1		M		1	
2.2	P/F	7.5.1, 9.2.1	M		0-1		M		0-1	
2.3	N(R)	7.5.2.6	M		0-7		M		0-7	
3	Checksum field	7.10	M				M			

Q.43 REJ-command/response (Reject)

Item no.	Name of information element and field element	Ref.	Sending (P to F)				Receipt (F to P)			
			Status	Supp.	Value		Status	Supp.	Value	
					Allowed	Supported			Allowed	Supported
1	Address field	7.2	M				M			
1.1	RES	7.3.1	M		1		M		1	
1.2	C/R	7.3.2	M		0-1		M		0-1	
1,3	SAPI	7.3.3	M		0		M		0	
1.4	LLN	7.3.5	M		1 C1 2-7 C2		M		1 C1 2-7 C2	
1.5	NLF	7.3.4, 9.2.2.1	M		0-1		M		0-1	
2	Control field	7.4	M				M			
2.1	S (Supervisory function bits)	7.5.2.4	M		2		M		2	
2.2	P/F	7.5.1, 9.2.1	M		0 C1 0-1 C2		M		0 C1 0-1 C2	
2.3	N(R)	7.5.2.6	M		0-1 C1 0-7 C2		M		0-1 C1 0-7 C2	
3	Checksum field	7.10	M				M			

Q.44 SABM-command (Set Asynchronous Balanced Mode)

Item no.	Name of information element and field element	Ref.	Sending (P to F)				Receipt (F to P)			
			Status	Supp.	Value		Status	Supp.	Value	
					Allowed	Supported			Allowed	Supported
1	Address field	7.2	M				M			
1.1	RES	7.3.1	M		1		M		1	
1.2	C/R	7.3.2	M		1		M		0	
1,3	SAPI	7.3.3	M		0		M		0	
1.4	LLN	7.3.5	M		1 C1 2-7 C2		M		1 C1 2-7 C2	
1.5	NLF	7.3.4, 9.2.2.1	M		0-1		M		0-1	
2	Control field	7.4	M				M			
2.1	U (Unnumbered function bits) length: 5 BIT (2+3)	7.5.2.4	M		7		M		7	
2.2	P	7.5.1, 9.2.1	M		0 C1 1 C2		M		0 C1 1 C2	
3	Checksum field	7.10	M				M			

Q.45 DM-response (Disconnect Mode)

Item no.	Name of information element and field element	Ref.	Sending (P to F)				Receipt (F to P)			
			Status	Supp.	Value		Status	Supp.	Value	
					Allowed	Supported			Allowed	Supported
1	Address field	7.2	M				M			
1.1	RES	7.3.1	M		1		M		1	
1.2	C/R	7.3.2	M		0		M		1	
1,3	SAPI	7.3.3	M		0		M		0	
1.4	LLN	7.3.5	M		1 C1 2-7 C2		M		1 C1 2-7 C2	
1.5	NLF	7.3.4, 9.2.2.1	M		0-1		M		0-1	
2	Control field	7.4	M				M			
2.1	U (Unnumbered function bits) length: 5 BIT (2+3)	7.5.2.4	M		3		M		3	
2.2	F	7.5.1, 9.2.1	M		0 C1 0-1 C2		M		0 C1 0-1 C2	
3	Checksum field	7.10	M				M			

Q.46 UI-command (Unnumbered Information)

Item no.	Name of information element and field element	Ref.	Sending				Receipt			
			Status	Supp.	Value		Status	Supp.	Value	
					Allowed	Supported			Allowed	Supported
1	Address field	7.2	M				M			
1.1	RES	7.3.1	M		1		M		1	
1.2	C/R	7.3.2	M		1		M		0	
1,3	SAPI	7.3.3	M		0		M		0	
1.4	LLN	7.3.5	M		1 C1 2-7 C2		M		1 C1 2-7 C2	
1.5	NLF	7.3.4, 9.2.2.1	M		0-1		M		0-1	
2	Control field	7.4	M				M			
2.1	U (Unnumbered function bits) length: 5 BIT (2+3)	7.5.2.4	M		0		M		0	
2.2	P	7.5.1, 9.2.1	M		0 C1 0-1 C2		M		0 C1 0-1 C2	
3	Checksum field	7.10	M				M			

Q.47 DISC-command (Disconnect)

Item no.	Name of information element and field element	Ref.	Sending (P to F)				Receipt (F to P)			
			Status	Supp.	Value		Status	Supp.	Value	
					Allowed	Supported			Allowed	Supported
1	Address field	7.2	M				M			
1.1	RES	7.3.1	M		1		M		1	
1.2	C/R	7.3.2	M		1		M		0	
1,3	SAPI	7.3.3	M		0		M		0	
1.4	LLN	7.3.5	M		1 C1 2-7 C2		M		1 C1 2-7 C2	
1.5	NLF	7.3.4, 9.2.2.1	M		0-1		M		0-1	
2	Control field	7.4	M				M			
2.1	U (Unnumbered function bits) length: 5 BIT (2+3)	7.5.2.4	M		8		M		8	
2.2	P	7.5.1, 9.2.1	M		0 C1 0-1 C2		M		0 C1 0-1 C2	
3	Checksum field	7.10	M				M			

Q.48 UA response (Unnumbered ACK)

Item no.	Name of information element and field element	Ref.	Sending (P to F)				Receipt (F to P)			
			Status	Supp.	Value		Status	Supp.	Value	
					Allowed	Supported			Allowed	Supported
1	Address field	7.2	M				M			
1.1	RES	7.3.1	M		1		M		1	
1.2	C/R	7.3.2	M		0		M		1	
1,3	SAPI	7.3.3	M		0		M		0	
1.4	LLN	7.3.5	M		1 C1 2-7 C2		M		1 C1 2-7 C2	
1.5	NLF	7.3.4, 9.2.2.1	M		0-1		M		0-1	
2	Control field	7.4	M				M			
2.1	U (Unnumbered function bits) length: 5 BIT (2+3)	7.5.2.4	M		12		M		12	
2.2	F	7.5.1, 9.2.1	M		0 C1 0-1C2		M		0 C1 0-1C2	
3	Checksum field	7.10	M				M			

F.2.3 Timers

F.2.3.1 C-plane timers

Q.61 C-plane timers

Supported timers						
Item no.	Timer	Ref.	Status	Supp.	Value	
					Allowed	Supported
1	DL.00	A.1	M		2 s	
2	DL.01	A.1	M		2 s	
3	DL.02	A.1	M		2 s	
4	DL.03	A.1	M		2 s	
5	DL.04 (CF routed frames)	A.1	M		1 s	
6	DL.04 (CS routed frames)	A.1	M		2 s	
7	DL.05	A.1	M		10 s	
8	DL.06	A.1	M		4 s	
7	DL.07	A.1	M		2 s	

F.2.4 Protocol error handling

F.2.4.1 C-plane protocol error handling

Q.63 General error handling

Supported procedures				
Item No	Operation - General procedures	Ref.	Status	Support
1	Invalid frames are discarded	9.2.9.1	M	

Q.64 Class A error recovery

Supported procedures				
Item No	Operation - General procedures	Ref.	Status	Support
1	Waiting for acknowledgement, timer DL.04 expiry	9.2.3.6	C1m	

Q.65 Class B error handling and recovery

Supported procedures				
Item No	Operation - General procedures	Ref.	Status	Support
1	N(S) sequence error	9.2.9.2.1	C2m	
2	N(R) sequence error	9.2.9.2.2	C2m	
3	Timer recovery condition	9.2.9.2.3	C2m	

Q.66 Unknown or invalid frames (which provoke error handling as requested in Q.63)

Supported frames				
Item No	Frame types	Ref.	Status	Support
1	Unknown frames	9.2.9.1, 7.11	M	
2	Invalid frames	6.1.5	M	

Annex G (informative): Profile selection coding

This annex contains the basic coding used for selection of the E data profile, mobility class 2, point-to-point (LRMS PTP) service.

G.1 <<BASIC SERVICE>> coding

Table G.1: <<Basic service>> default coding

Octet	Information element field	Field value
2	<Call Class> <Basic Service>	"Messaging Call Setup" " LRMS (E-profile) service " (note)
Note: A different basic service is used for GSM SMS interworking.		

G.2 <<IWU-ATTRIBUTES>> coding

Table G.2: <<iwu attributes>> default coding

Octet	Information element field	Field value
3	<Coding standard> <Profile>	"Profile defined coding" "E data profile"
4	<Negotiation indicator>	Value depends on the implementation

Rest of the codings are used for interworking service selection as defined in interworking annexes.

G.3 <<CONNECTION ATTRIBUTES>> coding

Table G.3: <<Connection attributes>> default coding

Octet	Information element field	Field value
3	<Symmetry> <Connection identity coding>	"Symmetric connection" "Unknown"
4	<Target number of bearers; P => F direction>	"No U-plane"
4b	<Target number of bearers; F => P direction>	"No U-plane"

Annex H (informative): Applicability of ETS 300 755 interworking annexes

The interworking annexes in ETS 300 755 [13] specifying the F.2 profile messaging service are also applicable to this ETS and vice versa. Although consideration has to be taken to the lower data throughput in the E.2 profile, i.e. it is for example not suitable to run a facsimile application on the E.2 profile, but short messages can without problems be send on the F.2 profile.

Annex J (informative): Interworking to other message-based teleservices and application-level services

J.1 General

The messaging service specified in this ETS also allows efficient interworking to other message-based teleservices and application-level services such as:

- World Wide Web / Hyper Text Transfer Protocol (WWW/HTTP);
- E-mail;
- File transfer (File Transfer Protocol (FTP), File Transfer Access & Management (FTAM) and Integrated Services Digital Network (ISDN) file transfer);
- Message waiting.

There may be subsequent amendments to this ETS or separate ETSs to fully specify the interworking for the above services.

J.2 WWW/HTTP

Using the messaging service for interworking to WWW/HTTP gives the advantage that the PP does not need to have a TCP/IP stack, which would require significant memory and complexity in the PP. This is especially useful to enhance a GAP handset with possibilities to not only receive (short) messages but also to be able to request WWW pages.

Another application might be a PDA with limited memory or a PP designated only for WWW/HTTP applications.

History

Document history			
May 1996	Public Enquiry	PE 106:	1996-05-20 to 1996-09-13
December 1996	Vote	V 117:	1996-12-23 to 1997-02-14