



EUROPEAN
TELECOMMUNICATION
STANDARD

FINAL DRAFT
pr **ETS 300 755**

February 1997

Source: ETSI EP-DECT

Reference: DE/DECT-020038

ICS: 33.020

Key words: Data, DECT, fax, mobility, profile, radio

**Radio Equipment and Systems (RES);
Digital Enhanced Cordless Telecommunications (DECT);
Data Services Profile (DSP);
Multimedia Messaging Service (MMS) with specific
provision for facsimile services;
(Service type F, class 2)**

ETSI

European Telecommunications Standards Institute

ETSI Secretariat

Postal address: F-06921 Sophia Antipolis CEDEX - FRANCE

Office address: 650 Route des Lucioles - Sophia Antipolis - Valbonne - FRANCE

X.400: c=fr, a=atlas, p=etsi, s=secretariat - **Internet:** secretariat@etsi.fr

Tel.: +33 4 92 94 42 00 - Fax: +33 4 93 65 47 16

Copyright Notification: No part may be reproduced except as authorized by written permission. The copyright and the foregoing restriction extend to reproduction in all media.

© European Telecommunications Standards Institute 1997. All rights reserved.

Contents

Foreword	9
1 Scope	11
2 Normative references	11
3 Definitions and abbreviations	13
3.1 Definitions	13
3.2 Abbreviations	14
4 Description of services	16
4.1 Reference configuration	16
4.2 Service description	16
4.3 Service objectives	17
4.3.1 Multi-bearer support	17
5 Functional description	18
5.1 General	18
5.2 MMS relations to outside networks (horizontal model)	18
5.3 Architecture	19
5.3.1 General	19
5.3.2 MMSP call control part (C-MMS)	20
5.3.3 MMSP messaging part (M-MMS)	20
5.4 MMS relations to the upper/lower layers (vertical model)	20
5.4.1 General	20
5.4.2 MMS relation to the DECT upper layers	21
5.4.2.1 General	21
5.4.2.2 M-MMS	21
5.4.2.3 C-MMS	21
5.5 MMS relations to outside networks (vertical and horizontal model)	22
5.5.1 General	22
5.5.2 Phases of the horizontal interactions	22
5.5.2.1 General	22
5.5.2.2 PP originated outgoing MMS call	22
5.5.2.3 Example of a typical PP initiated message	24
5.5.2.4 PP terminated incoming MMS call	24
5.6 MMS relations to the DECT Data Services Profiles (DSPs) E and F	25
5.6.1 General	25
5.6.2 E-profile and MMSP	25
5.6.3 F-profile and MMSP	25
6 Physical layer requirements	25
7 MAC layer requirements	25
8 DLC layer requirements	26
8.1 C-plane requirements	26
8.2 U-plane requirements	26
9 Network layer requirements	26
10 Management entity requirements	26
11 Generic interworking conventions	27
11.1 MMSP procedures	27
11.2 MMS-SAP	27

11.3	MMSP primitives	27
11.3.1	C-MMS primitives	27
11.3.2	M-MMS primitives	28
11.3.3	Parameters	28
Annex A (normative):	MMSP definition.....	29
A.1	MMSP protocol messages and procedures.....	29
A.1.1	General.....	29
A.1.2	C-MMS messages and procedures.....	29
A.1.3	M-MMS.....	30
A.1.3.1	Summary of the M-MMS messages	30
A.1.3.2	MMS SEND procedure	30
A.1.3.2.1	{MMS-SEND} message contents.....	31
A.1.3.2.2	{MMS-SEND-RPY} message contents	31
A.1.3.3	MMS SEND-REQ procedure	32
A.1.3.3.1	{MMS-SEND-REQ} message contents.....	32
A.1.3.3.2	{MMS-SEND-RPY} message contents	33
A.1.3.4	MMS RETRIEVE procedure	33
A.1.3.4.1	{MMS-RETRIEVE} message contents.....	34
A.1.3.4.2	{MMS-RETRIEVE-RPY} message contents	34
A.1.3.5	MMS RETRIEVE-HDR procedure	35
A.1.3.5.1	{MMS-RETRIEVE-HDR} message contents.....	35
A.1.3.5.2	{MMS-RETRIEVE-RPY} message contents	36
A.1.3.6	MMS-EXT-CMD procedure	36
A.1.3.6.1	{MMS-EXT-CMD} message contents	37
A.1.3.6.2	{MMS-EXT-CMD-RPY} message contents.....	37
A.1.3.7	MMS-STATUS procedures.....	37
A.1.3.7.1	{MMS-STATUS} message contents	38
A.1.3.7.2	{MMS-STATUS-RPY} message contents	38
A.1.3.8	MMS-ESC-CMD procedure	39
A.1.3.8.1	{MMS-ESC-CMD} message contents.....	39
A.1.3.8.2	{MMS-ESC-CMD-RPY} message contents	40
A.1.3.8.3	Generic interworking conventions for the {MMS-ESC-CMD} command and reply	40
A.1.3.9	Procedures for the use of the MMS-message identifier	40
A.1.3.10	Multi-part message procedures	41
A.1.3.10.1	Multi-part send procedures	41
A.1.3.10.2	Multi-part retrieve procedures	42
A.1.3.11	Unsupported MMS command and IE compatibility procedures.....	42
A.1.3.11.1	Unsupported MMS commands procedure	42
A.1.3.11.2	Unsupported Information elements procedure	42
A.2	MMSP information elements	42
A.2.1	Summary of M-MMSP information elements	42
A.3	Parameters of M-MMSP service primitives	43
A.3.1	M_MMS_SEND- {req, ind}	43
A.3.2	M_MMS_SEND_REQ- {req, ind}.....	44
A.3.3	M_MMS_SEND_RPY- {req, ind}.....	44
A.3.4	M_MMS_RETRIEVE- {req, ind}	45
A.3.5	M_MMS_RETRIEVE_RPY- {req, ind}.....	45
A.3.6	M_MMS_EXT_CMD- {req, ind}.....	46
A.3.7	M_MMS_EXT_CMD_RPY- {req, ind}.....	46
A.3.8	M_MMS_STATUS {req, ind}	47
A.3.9	M_MMS_STATUS_RPY- {req, ind}.....	47
A.3.10	M_MMS_ESC_CMD- {req, ind}.....	48
A.3.11	M_MMS_ESC_CMD_RPY- {req, ind}	48
Annex B (normative):	Support of MMSP by the DECT lower layers.....	49
B.1	Profile-specific information elements.....	49
B.1.1	MMS Generic Header information element.....	49

B.1.2	MMS Object Header information element.....	54
B.1.3	MMS Extended Header information element.....	60
B.2	LAPU Frame Format applicable for the F profile.....	62
B.2.1	The information field in case of SAPI 0.....	62
B.2.2	The information field in case of SAPI 3.....	62
B.3	C-MMS primitive mapping rules.....	62
B.4	M-MMS message mapping rules.....	63
B.4.1	General.....	63
B.4.2	Information Element Mapping Rules.....	63
Annex C (normative):	Interworking conventions for real-time facsimile group 3 (MMS to T.30 G3 interworking).....	64
C.1	Introduction and scope of annex.....	64
C.2	Definition of the services and features.....	64
C.3	Overview of the MMS requirements.....	65
C.3.1	Standardized symbols for the status columns.....	65
C.3.2	Outgoing Fax service.....	66
C.3.2.1	C-MMS requirements.....	66
C.3.2.2	M-MMS command requirements.....	67
C.3.2.3	M-MMS information element requirements.....	67
C.3.3	Incoming Fax service.....	68
C.3.3.1	C-MMS requirements.....	68
C.3.3.2	M-MMS command requirements.....	68
C.3.3.3	M-MMS information element requirements.....	68
C.4	M-MMS message IE requirements - Outgoing Fax service.....	69
C.4.1	MMS-SEND command.....	69
C.4.2	MMS-SEND-REQ command.....	69
C.4.3	MMS-SEND-RPY command.....	70
C.4.4	MMS-RETRIEVE command.....	70
C.4.5	MMS-RETRIEVE-RPY command.....	70
C.4.6	MMS-EXT-CMD command.....	71
C.4.7	MMS-EXT-CMD-RPY command.....	71
C.4.8	MMS-STATUS command.....	72
C.5	M-MMS message IE requirements - Incoming Fax service.....	72
C.5.1	MMS-SEND command.....	72
C.5.2	MMS-SEND-REQ command.....	73
C.5.3	MMS-SEND-RPY command.....	73
C.5.4	MMS-RETRIEVE command.....	74
C.5.5	MMS-RETRIEVE-RPY command.....	74
C.5.6	MMS-EXT-CMD command.....	75
C.5.7	MMS-EXT-CMD-RPY command.....	75
C.5.8	MMS-STATUS command.....	76
C.6	T.30 parameters to MMS IE mappings.....	76
C.6.1	DIS/DTC Capabilities mapping.....	76
C.6.2	DCS Capabilities mapping.....	78
C.7	Service specific Information Element codings.....	80
C.7.1	<<IWU-ATTRIBUTES>>.....	80
C.7.2	<<MMS-GENERIC-HDR>>.....	81
C.7.3	<<CALLED-PARTY-NUMBER>>.....	81
C.7.4	<<CALLED-PARTY-SUBADDR>>.....	81
C.7.5	<<CALLING-PARTY-NUMBER>>.....	82
C.7.6	<<MMS-OBJ-HDR>>.....	82
C.7.7	<<MMS-EXT-HDR>>.....	83

C.7.7.1	G3 Fax object parameters	84
C.7.7.2	G3 Fax transmission parameters	85
C.7.7.3	G3 Fax capabilities parameters	86
C.7.7.4	G3 Fax Called Subscriber Identity (CSI).....	89
C.7.8	<<USER-DATA>>	90
C.8	Interworking procedures - outgoing fax service.....	90
C.8.1	General procedures	91
C.8.1.1	Structure of a MMS fax message - multipart message procedures	91
C.8.1.2	Assignment of MMS message identifiers	92
C.8.1.3	Assignment of Multipart parent message identifiers.....	92
C.8.1.4	Management of MMS message and IE options.....	92
C.8.1.5	Procedure for support of Option O.4 - T.30 Error Correction Mode (ECM)..	92
C.8.2	Call setup procedures (T.30 phase A)	93
C.8.2.1	PP side procedures	93
C.8.2.2	FP side/IWU procedures	93
C.8.3	Service capability identification procedures (T.30 phase B.1).....	95
C.8.3.1	PP side procedures	95
C.8.3.1.1	Retrieval of FP and EE capabilities (Optional).....	95
C.8.3.1.2	Fax message to transmit	95
C.8.3.1.3	Fax message to retrieve and none to transmit (Optional)...	96
C.8.3.1.4	No Fax message to transmit or to retrieve.....	96
C.8.3.2	FP side/IWU procedures	96
C.8.3.2.1	Retrieval of FP and EE capabilities.....	97
C.8.3.2.2	PP has a Fax message to transmit.....	97
C.8.3.2.3	PP has no more fax messages to transmit.....	97
C.8.3.2.4	PP wishes to retrieve a fax message.....	97
C.8.4	Service negotiation procedures (T.30 phase B.2).....	98
C.8.4.1	PP side procedures	98
C.8.4.2	FP side/IWU procedures	98
C.8.5	Message transmission procedures (T.30 phase C)	99
C.8.5.1	PP side procedures	99
C.8.5.2	FP side/IWU procedures	99
C.8.6	Post-message procedures (T.30 phase D)	100
C.8.6.1	PP side procedures	100
C.8.6.1.1	More parts of the multi-part message to send (T.30 MPS)100	
C.8.6.1.2	Multi-part message finished but more fax messages to send (T.30 EOM)	100
C.8.6.1.3	Finished sending all messages and message parts (T.30 EOP)	101
C.8.6.2	FP side/IWU procedures	101
C.8.6.2.1	More parts of the multi-part message to send (T.30 MPS)102	
C.8.6.2.2	Multi-part message finished but more fax messages to send (T.30 EOM)	102
C.8.6.2.3	Finished sending all messages and message parts (T.30 EOP)	103
C.8.7	Call release procedures (T.30 phase E)	103
C.8.7.1	PP side procedures	103
C.8.7.2	FP side/IWU procedures	103
C.8.7.2.1	PP initiated normal release	103
C.8.7.2.2	FP initiated orderly release	104
C.8.7.2.3	FP initiated abnormal release	104
C.9	Interworking procedures - incoming fax service	111
C.9.1	General procedures	111
C.9.2	Call setup procedures (T.30 phase A)	111
C.9.2.1	FP side/IWU procedures	111
C.9.2.2	PP side procedures	112
C.9.3	Service capability identification procedures (T.30 phase B.1).....	112
C.9.3.1	FP side/IWU procedures	112
C.9.3.1.1	Retrieval of PP capabilities and transfer of PP/IWU capabilities to the EE.....	113
C.9.3.1.2	Retrieval of a fax message by the EE.....	113

C.9.3.2	PP side procedures	114
	C.9.3.2.1 Retrieval of PP capabilities (Optional)	114
	C.9.3.2.2 EE has no more fax messages to transmit.....	114
	C.9.3.2.3 Retrieval of a fax message by the EE	114
C.9.4	Service negotiation procedures (T.30 phase B.2)	115
	C.9.4.1 FP side/IWU procedures	115
	C.9.4.2 PP side procedures	116
C.9.5	Message transmission procedures (T.30 phase C).....	116
	C.9.5.1 FP side/IWU procedures	116
	C.9.5.2 PP side procedures	117
C.9.6	Post-message procedures (T.30 phase D).....	117
	C.9.6.1 FP side/IWU procedures	117
	C.9.6.1.1 More parts of the multi-part message to send (T.30 MPS).....	117
	C.9.6.1.2 Multi-part message finished but more fax messages to send (T.30 EOM)	118
	C.9.6.1.3 Finished sending all messages and message parts (T.30 EOP)	118
	C.9.6.2 PP side procedures	119
	C.9.6.2.1 More parts of the multi-part message to send (T.30 MPS).....	119
	C.9.6.2.2 Multi-part message finished but more fax messages to send (T.30 EOM)	120
	C.9.6.2.3 Finished sending all messages and message parts (T.30 EOP)	120
C.9.7	Call release procedures (T.30 phase E)	121
	C.9.7.1 FP side/IWU procedures	121
	C.9.7.1.1 PP initiated normal release.....	121
	C.9.7.1.2 EE/FP initiated orderly release	121
	C.9.7.1.3 EE/FP initiated abnormal release	121
	C.9.7.2 PP side procedures	121
	C.9.7.2.1 PP initiated normal release.....	121
	C.9.7.2.2 EE/FP initiated orderly release	121
Annex D (informative):	Interworking conventions for store and forward facsimile group 3	130
Annex E (informative):	Interworking conventions for the GSM facsimile group 3 service	131
Annex F (normative):	Service type C, class 2: Fixed termination NWK PICS proforma for E and F profile.....	132
F.1	Standardized symbols for the status column	132
F.2	Capabilities	133
	F.2.1 Major capabilities	133
	F.2.1.1 Services.....	133
	F.2.1.2 Timer support	134
Annex G (normative):	Service type C, class 2: Portable termination NWK PICS proforma for E and F profiles.....	146
G.1	Standardized symbols for the status column	146
G.2	Capabilities	147
	G.2.1 Major capabilities	147
	G.2.1.1 Services.....	147
Annex H (informative):	Applicability of ETS 300 757 interworking annexes.....	160

Annex J (Informative):	Interworking to other message-based teleservices and application-level services.....	161
J.1	General.....	161
J.2	WWW/HTTP	161
History	162

Foreword

This final draft European Telecommunication Standard (ETS) has been produced by the Digital Enhanced Cordless Telecommunications (DECT) Project of the European Telecommunications Standards Institute (ETSI), and is now submitted for the Voting phase of the ETSI standards approval procedure.

Proposed transposition dates	
Date of latest announcement of this ETS (doa):	3 months after ETSI publication
Date of latest publication of new National Standard or endorsement of this ETS (dop/e):	6 months after doa
Date of withdrawal of any conflicting National Standard (dow):	6 months after doa

Blank page

1 Scope

This European Telecommunication Standard (ETS) defines a profile for Digital Enhanced Cordless Telecommunications (DECT) systems conforming to ETS 300 175 [1] to [9]. It is part of a family of profiles which build upon and extend each other, aimed at the general connection of terminals supporting non-voice services to a fixed infra-structure, private and public.

This ETS specifies the type F service, mobility class 2, as described in ETR 185 [12]. It uses the C-plane and U-plane services provided by the data service profile type C, Class 2, ETS 300 651 [13]. Additional functionality is defined to provide a means for the high speed, acknowledged or unacknowledged, transfer of multimedia message objects, including group 3 facsimile. This service may be used for private and public roaming applications.

Annexes to this ETS contain interworking conventions to specific teleservices and application level services including group 3 facsimile. The messaging service specified in this ETS also allows efficient interworking to other message-based teleservices and application-level services, such as E-mail, World Wide Web (WWW) Hyper Text Transfer Protocol (HTTP) and file transfer (FTP, FTAM and ISDN file transfer). This messaging service has been optimized for the efficient utilization of the DECT air interface and guarantees interoperability for a minimum set of services independently of the terminal application.

This ETS defines the requirements on the Physical, MAC, DLC and Network layers of DECT. This ETS also specifies management entity requirements and generic Interworking Conventions which ensure the efficient use of the DECT spectrum.

2 Normative references

This ETS incorporates, by dated or undated reference, provisions from other publications. These normative references are cited at the appropriate places in the text and the publications are listed hereafter. For dated references, subsequent amendments to, or revisions of, any of these publications apply to this ETS only when incorporated in it by amendment or revision. For undated references the latest edition of the publication referred to applies.

- [1] ETS 300 175-1: "Radio Equipment and Systems (RES); Digital European Cordless Telecommunications (DECT); Common Interface (CI); Part 1: Overview".
- [2] ETS 300 175-2: "Radio Equipment and Systems (RES); Digital Enhanced Cordless Telecommunications (DECT); Common Interface (CI); Part 2: Physical layer (PHL)".
- [3] ETS 300 175-3: "Radio Equipment and Systems (RES); Digital European Cordless Telecommunications (DECT); Common Interface (CI); Part 3: Medium Access Control (MAC) layer".
- [4] ETS 300 175-4: "Radio Equipment and Systems (RES); Digital European Cordless Telecommunications (DECT); Common Interface (CI); Part 4: Data Link Control (DLC) layer".
- [5] ETS 300 175-5: "Radio Equipment and Systems (RES); Digital European Cordless Telecommunications (DECT); Common Interface (CI); Part 5: Network (NWK) layer".
- [6] ETS 300 175-6: "Radio Equipment and Systems (RES); Digital European Cordless Telecommunications (DECT); Common Interface (CI); Part 6: Identities and addressing".
- [7] ETS 300 175-7: "Radio Equipment and Systems (RES); Digital European Cordless Telecommunications (DECT); Common Interface (CI); Part 7: Security features".

- [8] ETS 300 175-8: "Radio Equipment and Systems (RES); Digital European Cordless Telecommunications (DECT); Common Interface (CI); Part 8: Speech coding and transmission".
- [9] ETS 300 175-9: "Radio Equipment and Systems (RES); Digital European Cordless Telecommunications (DECT); Common Interface (CI); Part 9: Public Access Profile (PAP)".
- [10] ETS 300 444 (1995): "Radio Equipment and Systems (RES); Digital European Cordless Telecommunications (DECT); Generic Access Profile (GAP)".
- [11] ETS 300 435: "Radio Equipment and Systems (RES); Digital European Cordless Telecommunications (DECT); Data Services Profile (DSP); Base standard including interworking to connectionless networks (service types A and B, Class 1)".
- [12] ETR 185: "Radio Equipment and Systems (RES); Digital European Cordless Telecommunications (DECT); Data Services Profile (DSP); Profile overview".
- [13] ETS 300 651: "Radio Equipment and Systems (RES); Digital Enhanced Cordless Telecommunications (DECT); Data Services Profile (DSP); Generic data link service; Service type C, class 2".
- [14] ITU-T Recommendation T.30: "Procedures for document facsimile transmission in the general switched telephone network".
- [15] ITU-T Recommendation T.4: "Standardization of Group 3 facsimile apparatus for document transmission".
- [16] ITU-T Recommendation T.6: "Facsimile coding schemes and coding control functions for Group 4 facsimile apparatus".
- [17] ITU-T Recommendation T.50: "International Reference Alphabet (IRA) (Formerly International Alphabet No. 5 or IA5) - Information technology - 7-bit coded character set for information interchange".
- [18] ITU-T Recommendation T.100: "International information exchange for interactive videotex".
- [19] ITU-T Recommendation T.101: "International interworking for videotex services".
- [20] ITU-T Recommendation T.434: "Binary file transfer format for the telematic services".
- [21] ITU-T Recommendation T.505: "Document application profile PM-26 for the interchange of enhanced structure, mixed content documents in processable and formatted forms".
- [22] ITU-T Recommendation T.611: "Programming Communication Interface (PCI) APPLI/COM for facsimile Group 3, facsimile Group 4, teletex, telex, E-mail and file transfer services".
- [23] ETS 300 757: "Radio Equipment and Systems (RES); Digital Enhanced Cordless Telecommunications (DECT); Data services profile; Low rate messaging service; (Service type E, class 2)".
- [24] ETS 300 792: "Radio Equipment and Systems (RES); Digital Enhanced Cordless Telecommunications / Global System for Mobile communications (DECT/GSM); DECT/GSM interworking profile; Implementation of facsimile group 3".

3 Definitions and abbreviations

3.1 Definitions

For the purposes of this ETS, the following definitions apply:

kbyte: 1 000 bytes.

Kbyte: 1 024 bytes.

mobility class 1: Local area applications, for which terminals are pre-registered off-air with one or more specific fixed parts, and establishment of service and user parameters is therefore implicit, according to a profile-defined list.

mobility class 2: Private and Public roaming applications for which terminals may move between fixed parts within a given domain and for which association of service parameters is explicit at the time of service request.

multiframe: A repeating sequence of 16 successive TDMA frames, that allows low rate or sporadic information to be multiplexed (e.g. basic system information or paging).

service type A: Low speed frame relay, with a net sustainable throughput of up to 24 kbits/s, optimized for bursty data, low power consumption and low complexity applications such as hand-portable equipment.

service type B: High performance frame relay, with a net sustainable throughput of up to 552 kbits/s, optimized for high speed and low latency with bursty data. Equipment implementing the Type B profile shall inter-operate with Type A equipment.

service type C: Non-transparent connection of data streams requiring Link Access Protocol (LAP) services, optimized for high reliability and low additional complexity. This builds upon the services offered by the type A or B profiles.

service type E: A short message transfer or paging service which may be unacknowledged or acknowledged, optimized for small SDUs, low PP complexity and ultra-low power consumption.

service type F: An application profile specifically supporting teleservices such as fax, building upon the services offered by the type A/B and C profiles, optimized for terminal simplicity, spectrum efficiency and network flexibility.

TDMA frame: A time-division multiplex of 10 ms duration, containing 24 successive full slots. A TDMA frame starts with the first bit period of full slot 0 and ends with the last bit period of full slot 23.

For annex C, the following additional definitions apply:

MMS-message attributes: The message meta-information.

minimal MMS-message attributes: The message meta-information used in the request-to-send, etc.

tonal signalling: The "tonal signalling for facsimile procedure" as defined in clause 4 of ITU-T Recommendation T.30 [14].

binary coded signalling: The "binary coded signalling for facsimile procedure" as defined in clause 5 of ITU-T Recommendation T.30 [14].

G3 RT fax application: An MMS application (at the PP) which provides a real-time group 3 fax application according to the rules and procedures specified in annex C of this ETS.

G3 RT fax IWU: An MMS IWU (in the FP) which provides real-time group 3 fax interworking according to the rules and procedures specified in annex C of this ETS.

CED: Called station identification (2 100 Hz tone) as specified in ITU-T Recommendation T.30 [14], subclause 4.3.3.2.

CSI: Called Subscriber Identification as specified in ITU-T Recommendation T.30 [14], subclause 5.3.6.1.1, 2).

DIS: Digital identification signal as specified in ITU-T Recommendation T.30 [14], subclause 5.3.6.1.1, 1).

DTC: Digital transmit command as specified in ITU-T Recommendation T.30 [14], subclause 5.3.6.1.2, 1).

DCS: Digital command signal as specified in ITU-T Recommendation T.30 [14], subclause 5.3.6.1.3, 1).

DCN: Disconnect as specified in ITU-T Recommendation T.30 [14], subclause 5.3.6.1.8, 1).

GAP handset: A handset complying to the requirements of ETS 300 444 [10].

TCF: Training check (1,5 seconds of zeros at fax high speed modulation) as specified in ITU-T Recommendation T.30 [14], subclause 5.3.6.1.3, 5).

TSI: Transmitting Subscriber Identification as specified in ITU-T Recommendation T.30 [14], subclause 5.3.6.1.3, 2).

FTT: Failure to train as specified in ITU-T Recommendation T.30 [14], subclause 5.3.6.1.8, 1).

CFR: Confirmation to receive as specified in ITU-T Recommendation T.30 [14], subclause 5.3.6.1.8, 1).

T.30 node "x": Refers to the nodes of the flow diagrams (figures 5.2A to 5.2B) in ITU-T Recommendation T.30 [14], where "x" is an alphanumeric designation identifying the node.

real-time fax: Refers to the direct time correspondence that exists regarding fax call states and fax message transfer states between the PP to FP and the IWU to the End Entity (EE) fax terminal equipment. This is in contrast the Store and Forward Fax service where no such time relationship is specified.

3.2 Abbreviations

For the purposes of this ETS, the following abbreviations apply:

ACK	Acknowledgement
AI	Air Interface
AMCI	Advanced MAC Connection Identifier
BFT	Binary File Transfer
BPAD	Bit Packet Assembler/Disassembler
C	higher layer control Channel (see CS and CF)
CC	Call Control (a network layer functional grouping)
CED	Called station identification (2 100 Hz tone)
CF	higher layer signalling Channel (Fast)
CFR	Confirmation to Receive
CISS	Call Independent Supplementary Services
CLMS	Connectionless Message Service
C-MMS	Call control part of the MMS
COMS	Connection Oriented Message Service
C-plane	Control Plane
CS	higher layer signalling Channel (Slow)
DCE	Data Circuit-terminating Equipment
DCN	Disconnect
DCS	Digital Command Signal
DECT	Digital Enhanced Cordless Telecommunications
DIS	Digital Identification Signal
DLC	Data Link Control (layer 2b of the DECT protocol stack)
DLEI	Data Link Endpoint Identifier (DLC layer)
DLI	Data Link Identifier (DLC layer)

DSP	Data Services Profile
DTC	Digital Transmit Command
DTE	Data Terminal Equipment
ECM	Error Correction Mode
EE	End Entity
Fax	Facsimile
FP	Fixed Part
FT	Fixed radio Termination
FTT	Failure To Train
G3	Group 3 (fax)
GAP	Generic Access Profile
GSM	Global System for Mobile communication
I	higher layer Information channel (see IP)
IE	Information Element
IP	higher layer Information channel (Protected)
IPUI	International Portable User Identity
ISDN	Integrated Services Digital Network
IWF	Interworking Functions
IWU	Interworking Unit
LAP-B	Link Access Procedure (Balanced)
LAP-C	Link Access Procedure (Control)
LAP-D	Link Access Procedure (ISDN D-channel)
LAP-U	Link Access Procedure (U-plane)
Lb	A DLC layer C-plane protocol entity
Lc	A DLC layer C-plane protocol entity
LCE	Link Control Entity
LLME	Lower Layer Management Entity
LLN	Logical Link Number (DLC layer)
LRMS	Low Rate Messaging Service
M	MAC control channel
MAC	Medium Access Control (layer 2a of the DECT protocol stack)
MCE	Message Control Entity
MCI	MAC Connection Identification
MM	Mobility Management
M-MMS	Messaging part of the MMS
MMS	Multimedia Messaging Service
MMSP	Multimedia Messaging Service Protocol
N	identities channel
NLF	New Link Flag
NWK	Network (layer 3 of the DECT protocol stack)
P	Paging channel
PAD	Packet Assembler-Disassembler
PARK	Portable Access Rights Key
PDU	Protocol Data Unit
PHL	Physical (layer 1 of the DECT protocol stack)
PICS	Protocol Implementation Conformance Statement
PP	Portable Part
PT	Portable radio Termination
PUN	Portable User Number
PUT	Portable User Type
Q	system information channel
RT	Real-Time
SAP	Service Access Point
SAPI	Service Access Point Identifier
SC	Short message service Centre
SDU	Service Data Unit
T.30	ITU-T Recommendation T.30 [14].
TAF	Terminal Adaptation Function
TCF	Training check
TDMA	Time Division Multiple Access
TPUI	Temporary Portable User Identity
U-plane	User Plane

4 Description of services

4.1 Reference configuration

The reference configuration for this profile shall be as shown in figure 1.

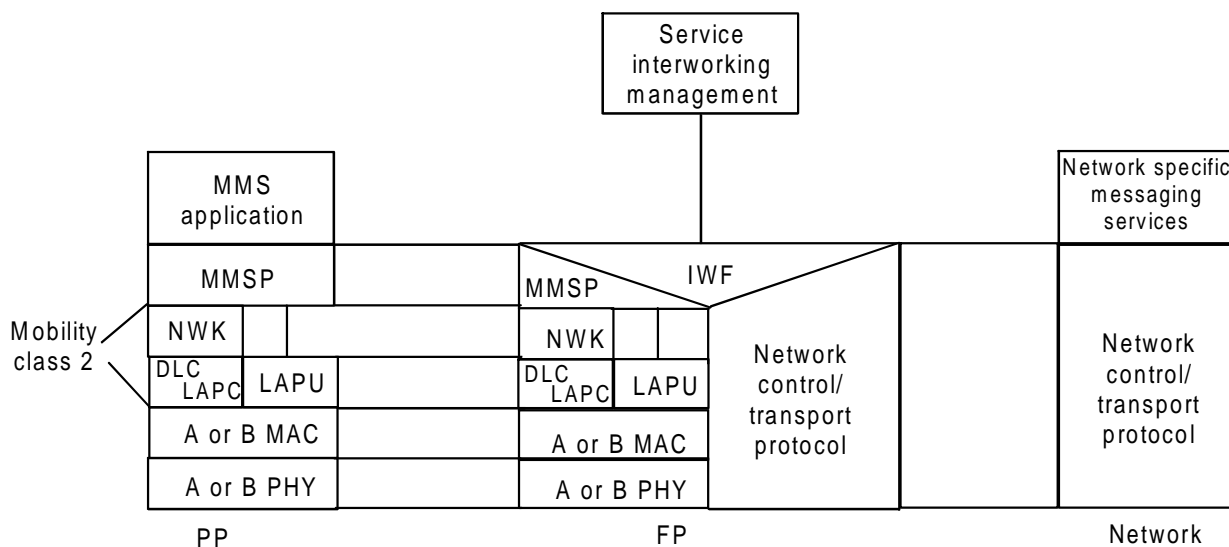

Figure 1: Profile reference configuration showing signalling and message interworking to networks via the C-plane and U-plane

4.2 Service description

The objectives of data profile service type F, class 2 Multimedia Messaging Service (MMS) are as follows:

The MMS is a generic set of commands, information elements and functionality for file/messaging service. In most of the cases MMS can be regarded as a DECT internal teleservice that can be interworked to the similar services in external networks. It provides a generic file handling/messaging services over the DECT air interface by utilizing the transportation mechanism of the DECT C-plane and U-plane in the best way possible while offering a general set of functions to the applications using its services. The MMS procedures can be accessed in a standardized way through a set of primitives.

MMS provides a compact subset of functions to information servers with the advantage that a single terminal with MMS support can use a wide variety of information and messaging services with minimum amount of application layer complexity. If a complete set of services is needed an escape sequence has to be used or some other means such as transparent protocol transportation mechanism are needed.

These objectives are fulfilled by Multimedia Messaging Service Protocol (MMSP).

Multimedia Messaging Service Protocol (MMSP) that is used for the provision of MMS services and functionality is a stateless protocol which defines a set of messages, framing rules and information elements each containing optional and mandatory information fields.

MMSP is stateless protocol layer which utilizes the services of the DECT Call Control and the U-plane LU3 services. It could be regarded as a supplementary service type of service that provides signalling/control and application specific information related to the teleservices provided by the DECT data profiles. The figure 2 illustrates a general view of the MMS capabilities and its intended usage.

The MMSP layer functionality is provided by a set of specific DECT network layer call control information elements. Therefore the MMSP is not from a DECT network layer viewpoint a separate real protocol layer but a service provided to the application. However, from an Application perspective the MMSP can be seen as a protocol layer. Therefore the MMSP can be regarded as a virtual protocol layer.

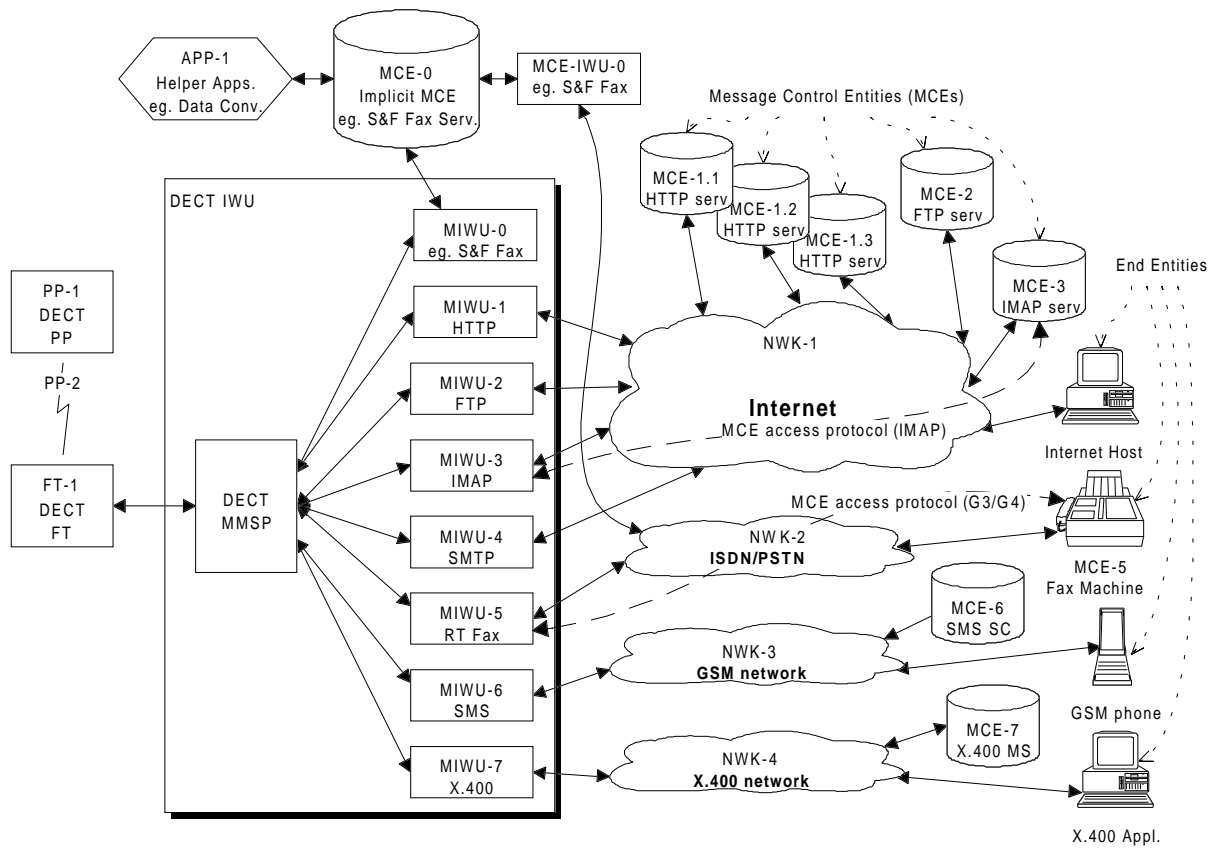

Figure 2: The MMS functional objectives and capabilities

4.3 Service objectives

The following service objectives shall apply:

Maximum sustainable throughput	24 kbit/s per bearer;
Establishment of PT to FT link	50 ms;
Establishment of FT to PT link	50 - 160 ms;
Undetected error rate	Less than 10^{-10} per bit;
Uncorrected error rate	Less than 10^{-9} per bit;
Services	point-to-point SDU transfer PP-FP; point-to-point SDU transfer FP-PP;
SDU buffer size	$\geq 1\ 500$ octets.

4.3.1 Multi-bearer support

As specified in clauses 6 to 10 of this ETS, the MMSP (for the F profile) uses the services specified by data service profile type C, mobility class 2 as defined in ETS 300 651 [13]. Therefore this profile also supports DECT multi-bearer services giving a maximum net (error-corrected) **throughput** of up to 552 kbit/s, or 69 kbyte/s (23 bearers x 24 kbit/s/bearer).

5 Functional description

5.1 General

This subclause defines the MMS definitions and functional model that are used in MMS service definition. The purpose of this subclause is to clarify the concepts relating to the MMS, its architecture, basic functionality and the relationship of the MMS to the DECT protocol layer model and to the outside networks. The concepts of vertical and horizontal models are only used to clarify the MMS interactions in this ETS and they were defined only for the purposes of clarity.

The horizontal MMS model defined in this subclause specifies the position of the MMS and the MMS entities in relation to the outside networks and DECT physical and logical entities (FPs, PPs and IWUs).

The architecture subclause defines the MMS layer internal structure.

The vertical MMS model defined in this subclause 5.4 specifies the position of the MMS in the DECT layer structure: relation to the DECT Network layer (NWK) and to the application/Interworking Unit (IWU).

5.2 MMS relations to outside networks (horizontal model)

This subclause defines the MMS horizontal definitions i.e. the relations of the messaging service to the outside networks as well as the different DECT MMS and outside (IWU) network entities. Figure 3 illustrates some of the MMS definitions.

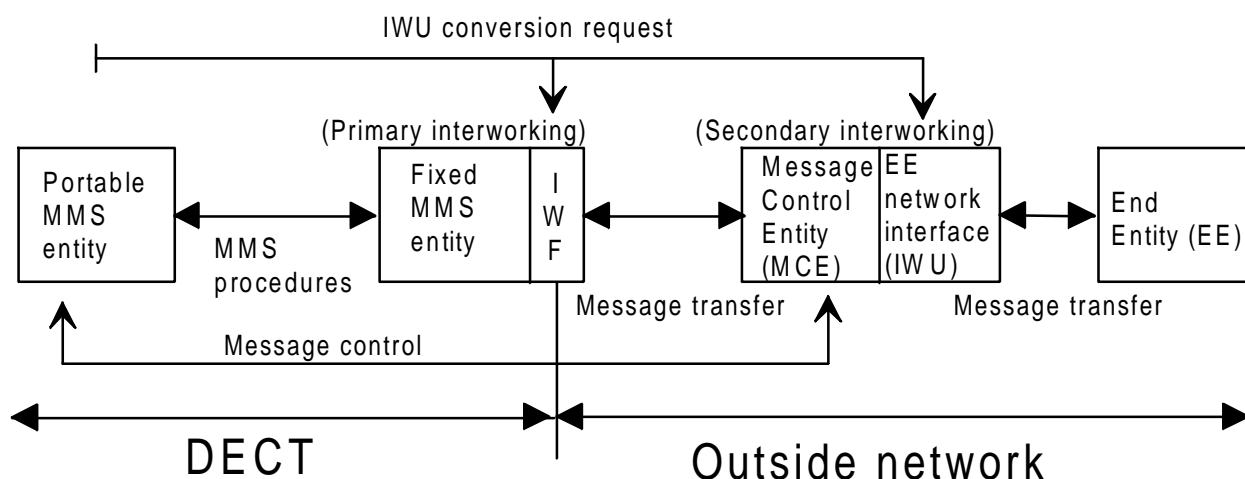

Figure 3: The MMS horizontal functional model

portable MMS entity: A PP which supports the MMS protocol (MMSP).

fixed MMS entity: A FP which supports the MMS protocol (MMSP) and which has an Interworking Function (IWF) between the MMSP and the outside network.

MMS entity (portable MMS entity or fixed MMS entity): an entity with MMS messaging capabilities

MMS procedure: MMS procedures take place between MMS entities. The procedures provide means for message and file transfer or retrieval between these MMS entities. Also a set of controlling procedures are available for the remote transactions focused into a MMS message/file stored/handled by the Message Control Entity (MCE). The MCE may send status information data as a response to a control procedure or to a specific request set by other MMS procedures.

Message Control Entity (MCE): A server which is responsible for the control of the message sent or requested by a MMS entity or the EE. It resides on the outside network side of the fixed MMS entity IWU. It is always logically separate from the fixed MMS entity, although they may be physically integrated. The protocol between the fixed MMS entity and the MCE as well as the protocol between the MCE and the EE (MCE IWU conversion) may be selected by means of MMS messages (primary IWU conversion). The selection of these protocols can be done by the MCE and/or by the fixed MMS entity. The MCE can be, for instance, a GSM Short message service Centre (SC) or a Fax server in LAN environment.

The Portable MMS entity can control the messages in the MCE i.e. request the status, cancel the message forwarding etc. After the MCE has finished forwarding the message (if it was requested to do so) the message cannot be controlled anymore. In this case only status information regarding the message can be requested from or sent by the MCE. The MCE may also send a message (or message acknowledgement) to the PP by establishing a connection to the Fixed MMS entity and requesting connection establishment to the appropriate Portable MMS Entity.

End Entity (EE): The EE is the final addressed destination of the message transfer. It is a logically separated from the MCE by either a network or a software interface. It does not necessarily understand MMS messaging i.e. the Fixed MMS Entity (FP IWU conversion) or the MCE end user network interface (secondary IWU conversion) may do protocol conversion according to the requests set in the MMS messages. The EE can also be another MMS entity. For instance, the Fixed MMS Entity can forward a MMS message to another Portable MMS Entity via a MCE.

MMS addressing: The MMS protocol provides for the addressing of the MCE and EE. The MCE address may be provided during the MMS call establishment. The EE address is sent in MMS messages. If no MCE address is present then the message is processed by a default or implicit MCE.

End entity network interface: The interface between the MCE and EE. For message transportation a MCE IWU can be requested in a MMS procedure. In this case a protocol conversion can take place according to the request of the MMS procedure or autonomously according to the interworking requirements.

5.3 Architecture

5.3.1 General

This subclause defines the MMSP virtual layer internal architecture.

The MMS Protocol (MMSP) entity is divided into two separate parts: the MMS call control entity (C-MMS) and the MMS messaging entity (M-MMS). The structure is illustrated in the figure 4. The use of the C-MMS and M-MMS primitives is service/application dependent and is described in the specific interworking descriptions.

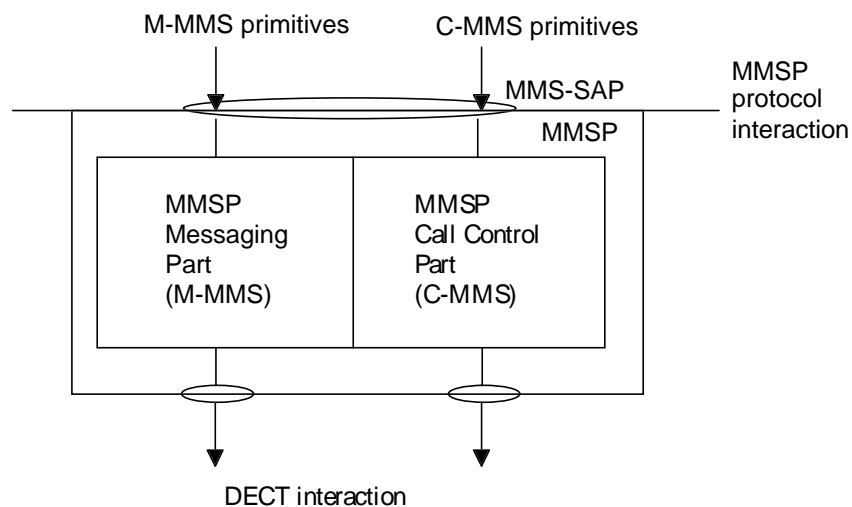

Figure 4: MMS internal structure

5.3.2 MMSP call control part (C-MMS)

The MMS call control part establishes a connection between a Portable and Fixed MMS entity according to the requests of the upper layer entity (MMS application or IWU). It forwards the call control requests to the lower layers. The C-MMS is controlled through the primitives of the MMS-SAP through which the required information for call establishment is defined.

5.3.3 MMSP messaging part (M-MMS)

The MMSP messaging part provides the means for the upper layer (MMS application or IWU) to send and receive MMS specific messages with MMS specific information between a Portable and Fixed MMS entity. The M-MMS part can only function if the C-MMS part has established a connection between these two horizontal entities according to the request of the upper layer entity. M-MMS provides a set of primitives to the upper layer and it contains MMSP message framing rules. The service access point for the primitives is the MMS-SAP. The use of the M-MMS primitives for a given MMS service is defined in the service/application interworking definitions and in the generic MMS procedures.

The MMSP data message information that is handled by the M-MMS part can be divided into two parts: Secondary part and Primary part data parts.

Secondary part provides the functionality to convey the pure data the user (application) wants to transmit e.g. a fax image data, the short message text, etc.

Primary part provides the functionality to convey the additional control data that is combined into the MMS message such as control information to the server, time stamp information, recipient address, response request.

5.4 MMS relations to the upper/lower layers (vertical model)

5.4.1 General

This subclause defines the MMS vertical relations. That is, how the MMSP interacts with the protocol layers on the top and below it. The interworking of the protocol is defined in both directions: up to the MMS application (in the PP) or the interworking unit (in the FP) and down to the DECT layers. The vertical model defines a standard set of primitives to the layer(s) above the MMS and defines their interaction with the DECT network and U-plane DLC layers. This information and the general interworking rules are defined in subclause 11 of this ETS. Service specific interworking is defined in the interworking annexes of this ETS. A general description of the MMSP interaction with the DECT upper protocol layers is defined in subclause 5.4.2.

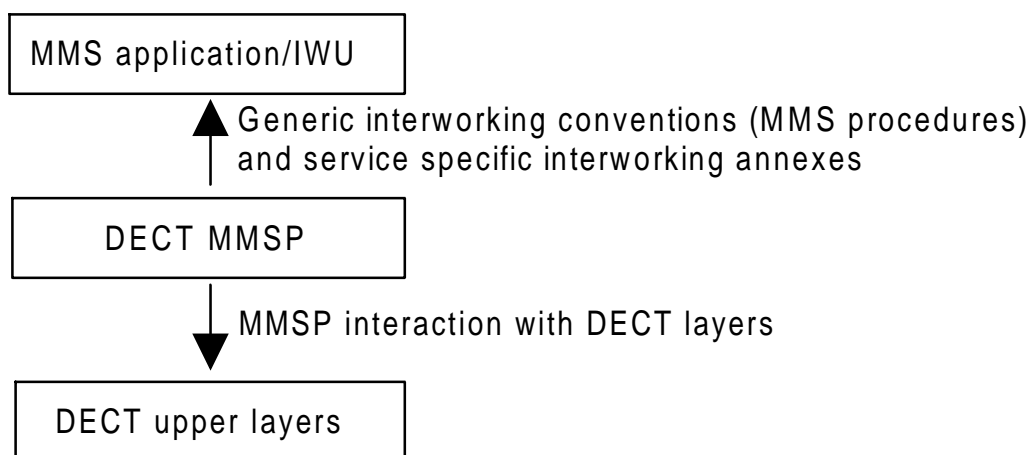

Figure 5: General vertical MMS model

The MMSP functions as a stateless protocol.

The task of the MMSP is to packetize the information received from the application, to add MMSP specific control information and to request the network layer and/or the U-plane DLC layer to transport the frames over the air interface to its peer MMSP entity. The MMSP layer provides primitives for call control and MMS transportation for the application layer and the entity uses NWK and/or DLC primitives. In general the MMS only does framing and in fact the call control primitives it offers to the application are network layer primitives. The procedures relating to call control behaviour are described in the interworking definitions due to the different type of functional demand by different services.

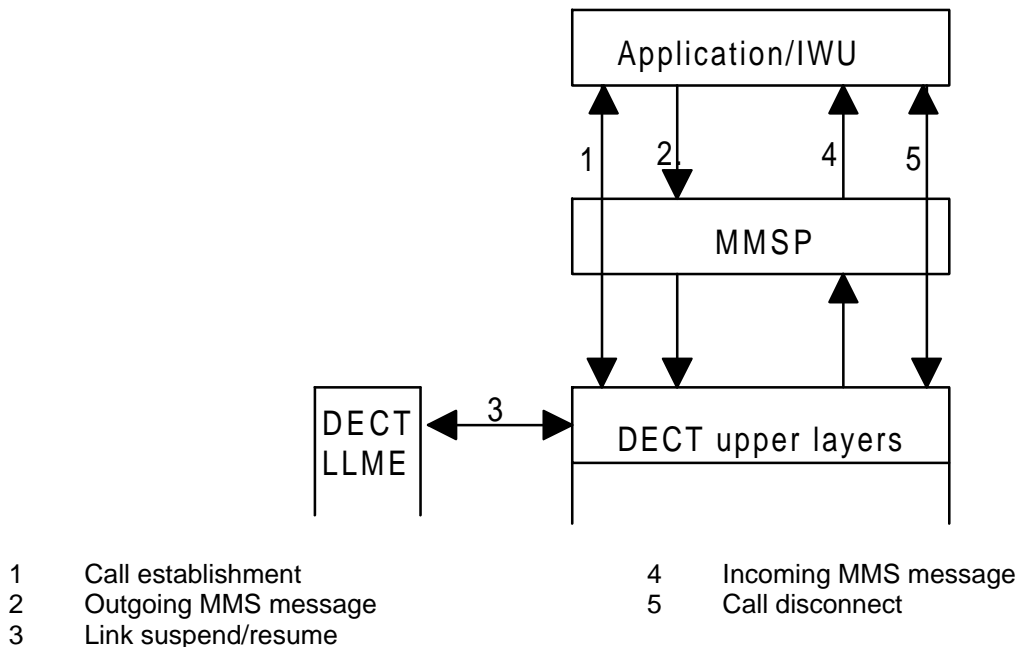

Figure 6: MMS interactions

5.4.2 MMS relation to the DECT upper layers

5.4.2.1 General

The interface between the MMSP protocol layer and the DECT upper layers is defined as a set of rules how the DECT NWK and DECT U-plane DLC primitives are used for MMS call control and MMS messaging.

5.4.2.2 M-MMS

M-MMS uses DECT Call Control messaging and information elements and DECT U-plane DLC layer for the MMS messages transfer. Thus M-MMS uses the Call Control and U-plane services. The interaction as well as the M-MMS procedures are defined as a mapping between the MMSP protocol messages and DECT NWK and DLC messages in annex B of this ETS.

5.4.2.3 C-MMS

C-MMS uses the normal DECT Call Control procedures for call establishment, suspension, resumption and release. Thus C-MMS is the same as DECT Call control entity. The interaction as well as the C-MMS procedures are defined as a mapping between the MMSP layer and DECT NWK messages in annex B of this ETS.

5.5 MMS relations to outside networks (vertical and horizontal model)

5.5.1 General

This subclause defines the MMS relations according to the horizontal model i.e. how the MMS protocol relates through the vertical model to the Portable MMS entity, Fixed MMS entity with Interworking Unit, MCE and outside network. The general model containing elements from both models is illustrated in figure 7. The functions in the figure in the EE are dependent on the accessed service.

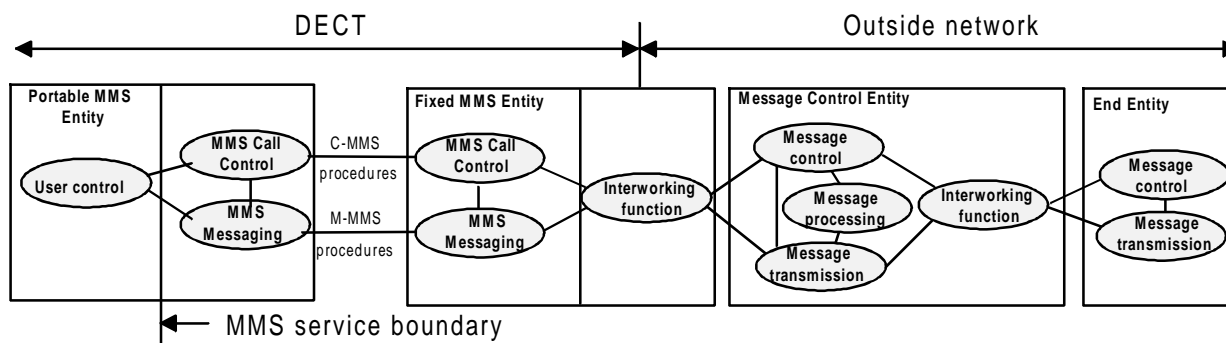

Figure 7: The MMS general functional model

5.5.2 Phases of the horizontal interactions

5.5.2.1 General

Figure 8 illustrates a general MMS horizontal functional model. It should be noted that the phases in the figure are not MMS procedures but basic functions required for reaching the interworking services. Those phases that have been drawn with dotted lines are optional i.e. these are not required by all services. A phase is part of a MMS procedure, either C-MMS or M-MMS, thus a MMS procedure consists of MMS phases defined here. Each phase is defined next with a reference to the figure 8 which illustrates a PP originated messaging transfer.

5.5.2.2 PP originated outgoing MMS call

Phase 1 a) Establish a call. This is a C-MMS phase. Its purpose is to establish a DECT air interface connection with MMS capabilities.

Phase 1 b) Select an FP IWU and negotiate the service. This is a C-MMS phase. Its purpose is to select the Interworking Unit in the Fixed MMS entity in order to facilitate the required message mappings and access to the requested service.

Phase 1 c) Request the MCE. This is a C-MMS phase. The MCE is accessed through a network to which the Fixed MMS entity provides access. This phase is used to address the MCE (for instance, Internet address, GSM SMS SC number, etc.). The MCE selected by the MMS protocol may be a default or implicit MCE.

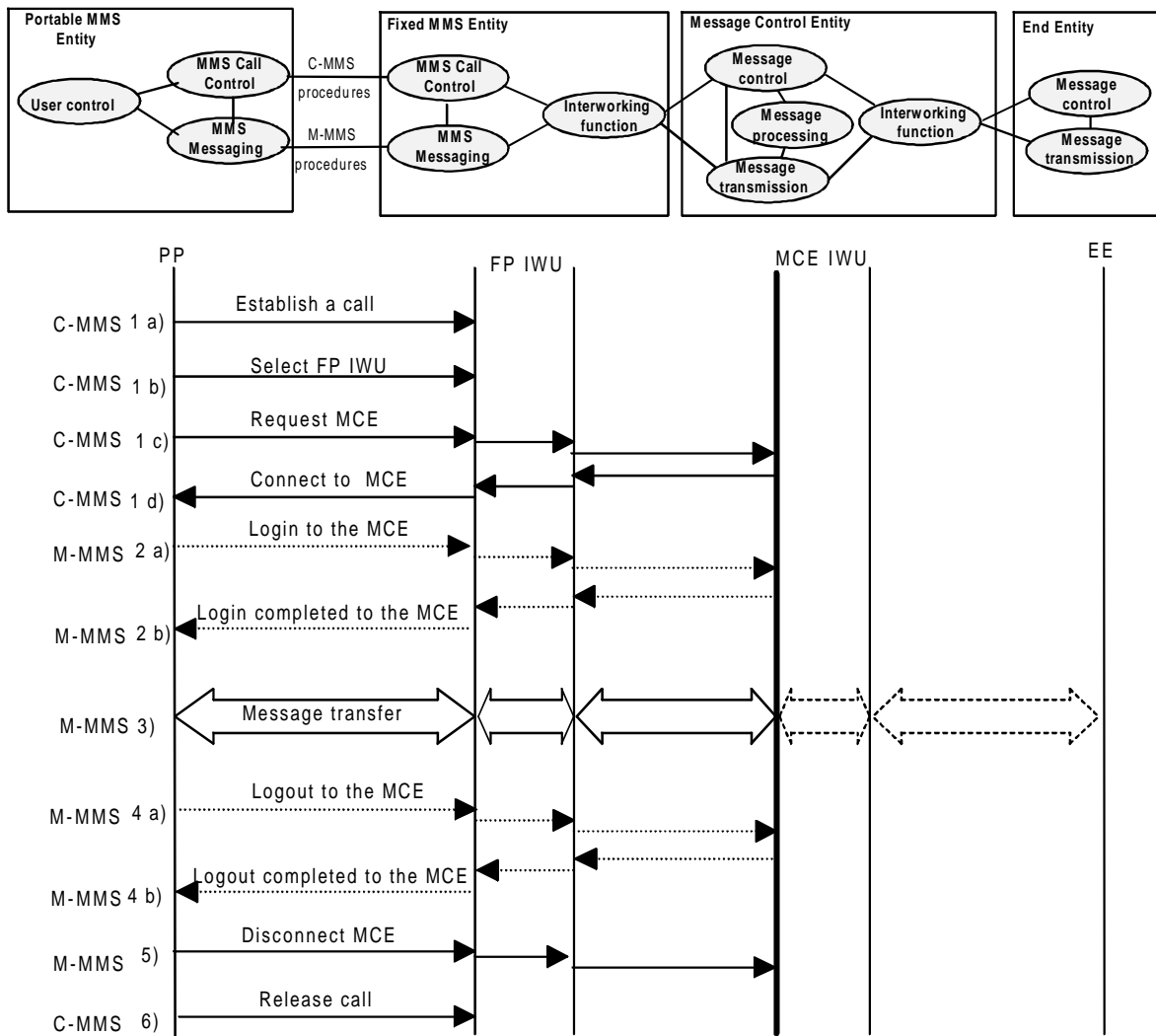

Figure 8: The horizontal functions related to MMS messaging

Phase 1 d). Connect to MCE. This is a C-MMS phase. The connection is established through the network into the MCE.

Phase 2 a). Send login request to MCE. This is an optional M-MMS phase. In some cases a login phase by a user or application is required to permit access to the service provided by the server (for instance, in the FTP service case).

Phase 2 b). Receive login reply from MCE. This is an optional M-MMS phase. In some cases login connect confirmation information is sent to the user by the MCE (the server).

Phase 3. Message transfer. This is a M-MMS phase. Contains messages that are transferred between the portable MMS entity and the MCE. Messages sent to a MCE may be forwarded to an EE. A typical example of this phase is illustrated in figure 9.

Phase 4 a). Send logout request to MCE. This is an optional M-MMS phase. In some cases a logout phase by a user or application is required to close a connection to the MCE.

Phase 4 b). Receive logout reply from MCE. This is an optional M-MMS phase. In some cases a logout confirmation information is sent to the user by the MCE (the server).

Phase 5. Disconnect from MCE. This is a M-MMS phase. This is a phase used to disconnect the connection to a server residing in a network (for instance, in Internet).

Phase 6. Release call. This is a C-MMS phase. This is a phase used to disconnect the air interface.

5.5.2.3 Example of a typical PP initiated message

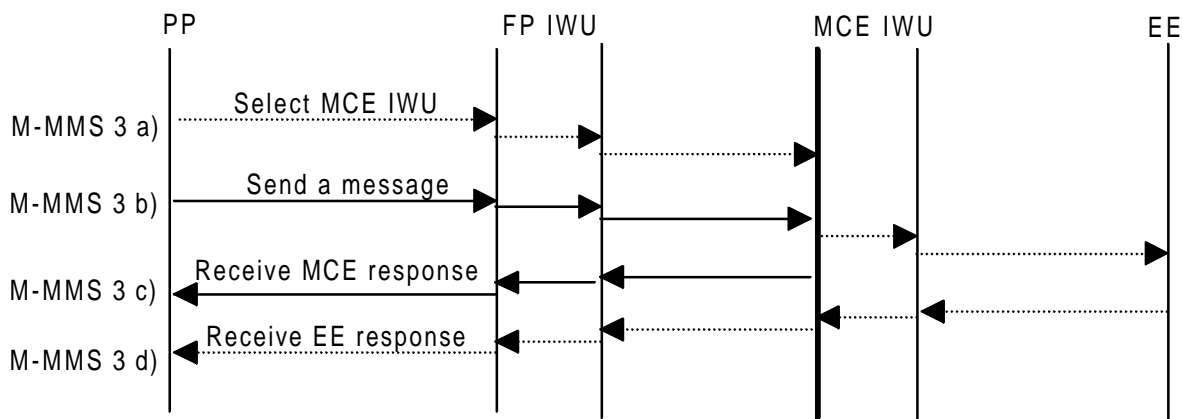

Figure 9: A typical phase 3 message change sequence

Phase 3 a). Select MCE IWU. This is a M-MMS phase. The purpose is to select the Interworking Unit in the MCE in order to facilitate the required message mappings or to reach required service.

Phase 3 b). Send a message. This is a M-MMS phase. This phase contains the actual message that is sent to the MCE for processing. Depending on the service either the MCE replies itself or forwards the message and then replies.

Phase 3 c). Receive MCE response. This is a M-MMS phase. The MCE has sent a response to the previously sent message.

Phase 3 d). Receive end entity response. This is a M-MMS phase. The MCE may send a response received from the EE to the MMS portable entity.

A set of consecutive phases can be combined into a single C- or M-MMS procedure. For example, phases 1a (establish a radio link), 1b (select FP IWU) and 1c (request the MCE) can be done with a CC-SETUP message.

5.5.2.4 PP terminated incoming MMS call

A PP terminated messaging consist only of phases 1 a), 1 b), 3 and 6. In this case the reference to the FP is replaced with PP as well as the direction of the phases is opposite to the PP originated case.

Phase 1 a) Establish a call.

Phase 1 b) Select a PP IWU and negotiate the service.

Phase 3 Message transfer.

Phase 3 b) Receive a message.

Phase 3 c) Send a MCE response.

Phase 6 Release call.

No other phases are required.

5.6 MMS relations to the DECT Data Services Profiles (DSPs) E and F

5.6.1 General

Both the E and F profiles shall use the MMSP protocol for upper layer service provision. Therefore the profiles are very closely aligned and one may be easily added to the other while continuing to use the same applications.

The relations of the E and F data profiles is illustrated in figure 10.

5.6.2 E-profile and MMSP

The Low Rate Messaging Service (LRMS), (E data profile) is used for MMSP based short message transfer. In this case both the primary and secondary parts are conveyed through the C-plane part. The C-MMS part, which is used for call control, is always conveyed through the C-plane.

5.6.3 F-profile and MMSP

The Multimedia Messaging Service (MMS), (F data profile) is used for MMSP based high speed data transfer. In this case the secondary part is conveyed through the U-plane using LU3-SAP and the primary part is conveyed through the C-plane, as in the E profile. The C-MMS part, which is used for call control, is always conveyed through the C-plane.

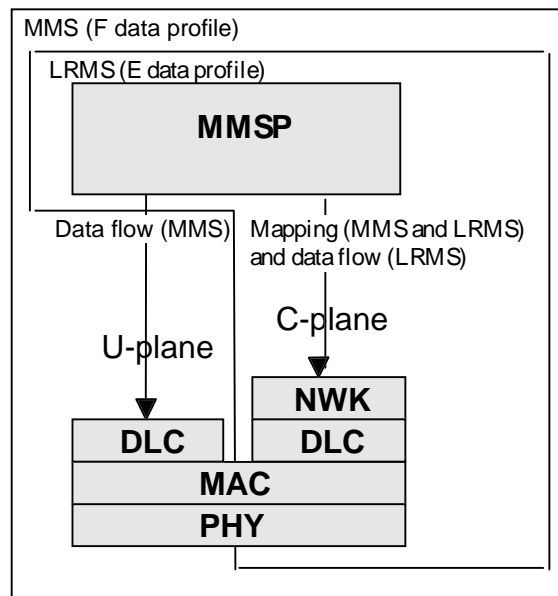

Figure 10: MMSP relations to the data profiles

6 Physical layer requirements

The requirements of the service types A and B, defined in ETS 300 435 [11] shall apply.

7 MAC layer requirements

The requirements of the service types A and B, defined in ETS 300 435 [11] shall apply including those elements described as conditional on the presence of service type C, class 2.

8 DLC layer requirements

The DLC layer shall contain two independent planes of protocol: the C-plane and the U-plane.

8.1 C-plane requirements

The DLC C-plane requirements of the ETS 300 651 [13] shall apply.

8.2 U-plane requirements

The requirements of LAPU as specified in the data service profile type C, class 2 defined in ETS 300 651 [13] shall apply.

9 Network layer requirements

The requirements of the service type C, mobility class 2, defined in ETS 300 651 [13] shall apply with the additions of the Profile ICS tables given in annexes F and G.

A new optional data profile specific procedure called profile up and downgrading procedure is defined. The following rules shall apply for the data profile relations and profile upgrading/downgrading procedures:

- if the existing connection is based on C.2 data profile ETS 300 651 [13] and the MMSP is activated to the same Call Control transaction, the bearer service connection is upgraded into MMS teleservice connection (the data service profile service type annex C, clause C.2, defined in this ETS). A downgrading is possible from F.2 profile into the C.2 profile by deactivating the MMSP layer. This procedures shall be done with {CC-SERVICE-CHANGE} message with "Profile/Basic Service and IWU attributes change" in the <Change mode coding> field;
- if the existing connection is based on E.2 data profile, ETS 300 757 [23] and the C.2 profile ETS 300 651 [13] U-plane is activated to the same Call Control transaction the LRMS teleservice connection is upgraded into MMS (F.2 data profile, this ETS) connection. A downgrading is possible from F.2 profile into the E.2 profile by deactivating the U-plane connection. These procedures shall be done with {CC-SERVICE-CHANGE} message with "Bandwidth change" coding in the <Change mode coding> field;
- the C.2 and E.2 can exist at the same time in a same terminal with separate transactions as well as F.2 and E.2.
- when E and F profile call is established the systems initiates the MMSP by default.

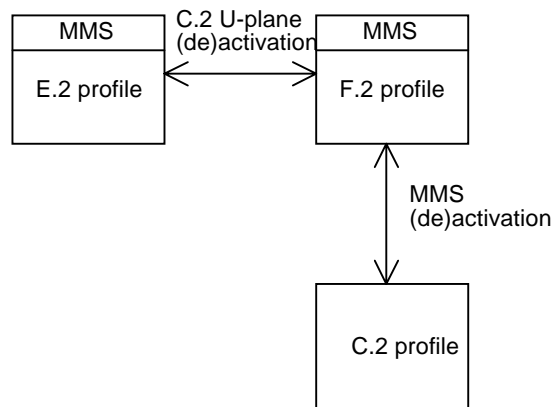

Figure 11: The upgrading/downgrading procedures

10 Management entity requirements

The requirements of the service types C, mobility class 2, defined in ETS 300 651 [13] shall apply.

11 Generic interworking conventions

11.1 MMSP procedures

The MMSP protocol messages and elements of procedure are defined in annex A, clause A.1 of this ETS.

The MMSP information elements are defined in annex A, clause A.2 of this ETS.

11.2 MMS-SAP

The MMS-SAP is the service access point on the top of MMSP that shall be accessed by the interworking unit (IWU) or the MMS application. The M-MMS-SAP primitives are used for MMS call control and for requesting MMS message transportation or reception directly by the upper layer application. The main call control functionality for different services is done as defined in an appropriate service interworking definition. The MMS-SAP primitives have been defined in subclause 11.3 of this ETS.

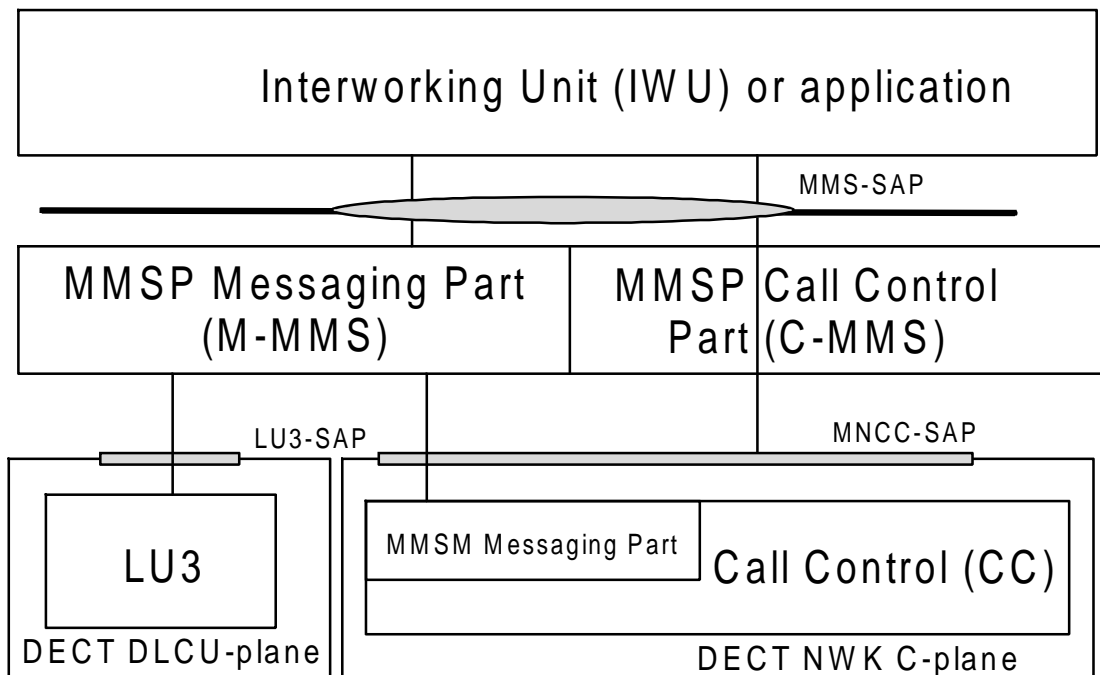

Figure 12: The MMS model

11.3 MMSP primitives

11.3.1 C-MMS primitives

The following primitives are provided by MMS-SAP for the control of C-MMS part of the MMSP.

Primitive	req	cfm	ind	res
C_MMS_SETUP-	x		x	
C_MMS_CONNECT-	x	x	x	
C_MMS_RELEASE-	x	x	x	x
C_MMS_MODIFY-	x	x	x	

11.3.2 M-MMS primitives

The following primitives are provided by MMS-SAP for the control of M-MMS part of the MMSP.

Primitive	req	cfm	ind	res
M_MMS_END-	x		x	
M_MMS_SEND-REQ-	x		x	
M_MMS_SEND-RPY-	x		x	
M_MMS_RETRIEVE-	x		x	
M_MMS_RETRIEVE_HDR-	x		x	
M_MMS_RETRIEVE_RPY-	x		x	
M_MMS_STATUS-	x		x	
M_MMS_STATUS-RPY-	x		x	
M_MMS_EXT_CMD-	x		x	
M_MMS_EXT_CMD-RPY-	x		x	
M_MMS_ESC_CMD-	x		x	
M_MMS_ESC_CMD_RPY-	x		x	

11.3.3 Parameters

The parameters for each primitive are described in annex A, clause A.3.

Annex A (normative): MMSP definition

A.1 MMSP protocol messages and procedures

A.1.1 General

The MMS is a stateless protocol offering a service defined by primitives, with peer-to-peer interactions described where appropriate in terms of virtual messages. These virtual messages and their information elements are implemented by mappings onto network layer messages and information elements. This annex describes the MMSP protocol layer only, whereas the mappings to the network layer are described in annex B.

Not all the MMSP messages and procedures are required in order to interwork to a specific interworking service i.e. a minimum subset of the following procedures, information elements and messages can be selected in order to facilitate interworking. However there is no limitation on implementing others in addition to the minimum required set. The procedures are defined as interactions between the MMS application layer or IWU and the MMSP primitives. The primitives, messages and procedures are divided into M-MMS and C-MMS parts.

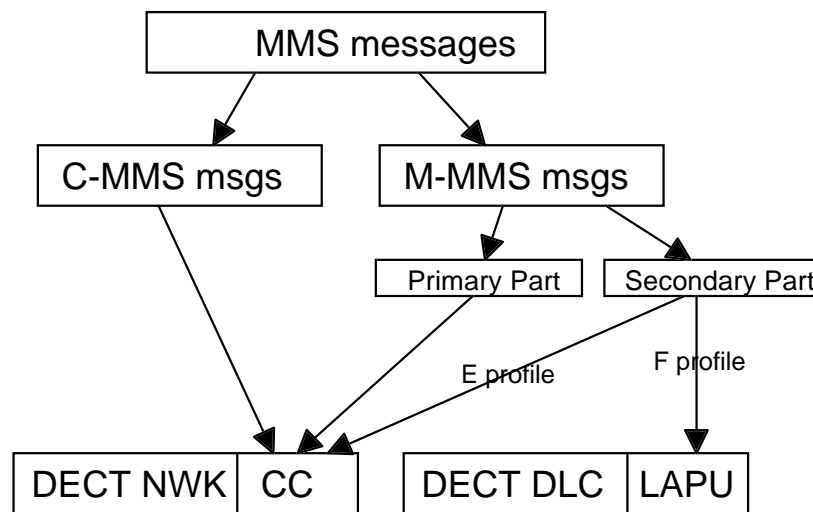

Figure A.1: The MMS message relationships

In the procedure specification the MMS entity which initiates a procedure is called the MMS initiating entity and the MMS entity which is the receiving part is called the MMS receiving entity.

A.1.2 C-MMS messages and procedures

There are no C-MMS virtual messages or procedures. All service requests to the C-MMS entity via its service primitives, and their associated parameters are mapped directly onto network layer CC primitives and parameters on a one-to-one basis as described in annex B.

A.1.3 M-MMS

The M-MMS protocol layer consists of a set of messages which are mapped directly from or to the corresponding M-MMS service primitives defined in clause 11. For transmission, these messages are parsed and directly mapped onto protocol elements (messages, information elements and SDUs) of the DECT C- and U-planes according to the rules given in annex B. On reception, the protocol elements received by the DECT C- and U-planes are parsed into M-MMS messages which are then mapped onto the corresponding M-MMS service primitives.

For clarity, the procedures which the higher-layer entity needs to adopt in the usage of the M-MMS service primitives have been presented here as elements of procedure for the use of the M-MMS messages, to which they are functionally equivalent.

NOTE: The M-MMS itself is a stateless protocol, and all implied states and procedures are the responsibility of the higher-layer entity, and will not be checked by the M-MMS.

A.1.3.1 Summary of the M-MMS messages

Table A.1: Summary of M-MMS messages

Message	Direction	Subclause
MMS-SEND	Both	A.1.3.2.1
MMS-SEND-REQ	Both	A.1.3.3.1
MMS-SEND-RPY	Both	A.1.3.2.2 & A.1.3.3.2
MMS-RETRIEVE	Both	A.1.3.4.1
MMS-RETRIEVE-HDR	Both	A.1.3.5.2
MMS-RETRIEVE-RPY	Both	A.1.3.4.2 & A.1.3.5.2
MMS-EXT-CMD	Both	A.1.3.6.1
MMS-EXT-CMD-RPY	Both	A.1.3.6.2
MMS-STATUS	Both	A.1.3.7.1
MMS-STATUS-RPY	Both	A.1.3.7.2
MMS-ESC-CMD	Both	A.1.3.8.1
MMS-ESC-CMD-RPY	Both	A.1.3.8.2

The M-MMS procedures shall only be invoked by the higher-layer entity when the CC entity, as seen by the higher-layer entity through the C-MMS service interface, is in the active state.

The messages are composed of a set of information elements. The first element <<MMS-Header>> contains the coding defining which message is being sent.

A.1.3.2 MMS SEND procedure

The MMS SEND procedure shall be used by an application or MCE to send a message to its peer. The procedure may be used in either direction (PP to FP and FP to PP). The reply is an optional feature which may be requested with the "Reply from MCE" or "Reply from MCE and EE" codings in the "reply request" field of the first IE of the {MMS-SEND} message. The content of the {MMS-SEND} message is defined in the table A.2 and of {MMS-SEND-RPY} in the table A.3. The procedures for the use of the MMS-Message Identifier shall be followed.

Upon receipt of a M_MMS_SEND-req primitive from the upper layer the M-MMS part of the MMS initiating entity shall send a corresponding {MMS-SEND} message to the receiving MMS entity. When a MMS entity receives a {MMS-SEND} message it shall issue a M_MMS_SEND-ind to the upper layer. If the <<MMS-Header>> is set to "reply requested" then the higher entity at the receiver shall upon completion of the appropriate action issue a M_MMS_SEND-RPY-req primitive and the MMS entity shall send a corresponding {MMS-SEND-RPY} message. Upon receipt of a {MMS-SEND-RPY} message from the receiving MMS entity the initiating MMS entity shall issue a M_MMS_SEND-RPY-ind primitive to the upper layer.

If the "Reply request" coding in the <<MMS-GENERIC-HDR>> element is set to "reply from EE", then the {MMS-SEND-RPY} message shall not be sent by the peer entity, and the initiating higher-layer entity shall expect the response in an M_MMS_STATUS_RPY-ind primitive.

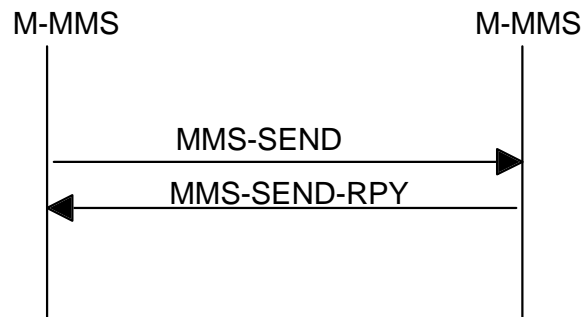

Figure A.2: MMS send procedure options

A.1.3.2.1 {MMS-SEND} message contents

Table A.2

{MMS-SEND} IEs	Syntax status	Description
PRIMARY PART		
MMS-Generic-Hdr	M	MMS command and service
Called-Party-Number	O	EE address
Called-Party-Subaddr	O	EE subaddress
Calling-Party-Number	O	initiating entity (PP or MCE) address
Time-Date	O	time & date of various message aspects
MMS-Obj-Hdr	M	user data length and type
MMS-Ext-Hdr	O	service or message specific attributes
Segmented-Info	O	segments of a network layer message
Repeat-Indicator	O	repetition of a particular IE
SECONDARY PART		
MMS-Ext-Hdr	O	service or message specific attributes
Repeat-Indicator	O	repetition of a particular IE
User Data	O	This IE contains the User Data

A.1.3.2.2 {MMS-SEND-RPY} message contents

Table A.3

{MMS-SEND-RPY} IEs	Syntax status	Description
PRIMARY PART		
MMS-Generic-Hdr	M	MMS command and service
Time-Date	O	time & date of various message aspects
MMS-Obj-Hdr	O	user data length and type
MMS-Ext-Hdr	O	service or message specific attributes
Segmented-Info	O	segments of a network layer message
Repeat-Indicator	O	repetition of a particular IE
SECONDARY PART		
MMS-Ext-Hdr	O	service or message specific attributes
Repeat-Indicator	O	repetition of a particular IE

A.1.3.3 MMS SEND-REQ procedure

The MMS SEND-REQ(uest) procedure shall be used by an application or MCE to provide information to its peer about a message it intends to send and shall require a reply, in order to enable the application or MCE to decide whether to initiate a MMS-SEND procedure. A reply shall always be requested, in the "reply request" field.. The content of the {MMS-SEND-REQ} message is defined in the table A.4 and of {MMS-SEND-RPY} in the table A.5. The procedures for the use of the MMS-Message Identifier shall be followed.

Upon receipt of a M_MMS_SEND_REQ-req primitive from the upper layer the M-MMS part of the MMS initiating entity shall send a corresponding {MMS-SEND-REQ} message to the receiving MMS entity. When a MMS entity receives a {MMS-SEND-REQ} message it shall issue a M_MMS_SEND_REQ-ind to the upper layer. Upon completion of the appropriate action the receiver higher layer entity shall issue a M_MMS_SEND_RPY-req primitive and the MMS entity shall send a corresponding {MMS-SEND-RPY} message. Upon receipt of a {MMS-SEND-RPY} message from the receiving MMS entity the initiating MMS entity shall issue a M_MMS_SEND_RPY-ind primitive to the upper layer.

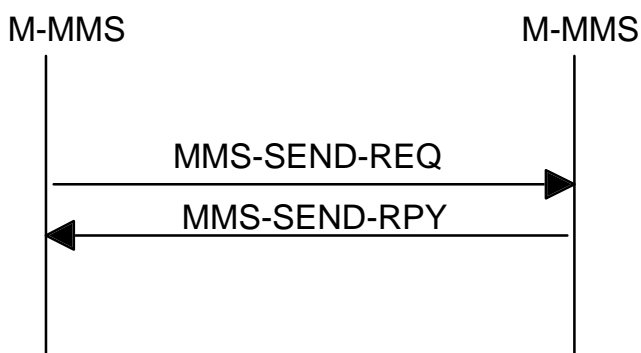

Figure A.3: MMS send procedure options

A.1.3.3.1 {MMS-SEND-REQ} message contents

Table A.4

{MMS-SEND-REQ} IEs	Syntax status	Description
PRIMARY PART		
MMS-Generic-Hdr	M	MMS command and service
Called-Party-Number	O	EE address
Called-Party-Subaddr	O	EE subaddress
Calling-Party-Number	O	initiating entity (PP or MCE) address
Time-Date	O	time & date of various message aspects
MMS-Obj-Hdr	M	user data length and type
MMS-Ext-Hdr	O	service or message specific attributes
Segmented-Info	O	segments of a network layer message
Repeat-Indicator	O	repetition of a particular IE
SECONDARY PART		
MMS-Ext-Hdr	O	service or message specific attributes
Repeat-Indicator	O	repetition of a particular IE

A.1.3.3.2 {MMS-SEND-RPY} message contents

Table A.5

{MMS-SEND-RPY} IEs	Syntax status	Description
PRIMARY PART		
MMS-Generic-Hdr	M	MMS command and service
Time-Date	O	time & date of various message aspects
MMS-Obj-Hdr	O	user data length and type
MMS-Ext-Hdr	O	service or message specific attributes
Segmented-Info	O	segments of a network layer message
Repeat-Indicator	O	repetition of a particular IE
SECONDARY PART		
MMS-Ext-Hdr	O	service or message specific attributes
Repeat-Indicator	O	repetition of a particular IE

A.1.3.4 MMS RETRIEVE procedure

The MMS RETRIEVE procedure shall be used by an application or MCE to request from its peer the transmission of a message or messages, and shall always involve a reply, in order to convey the retrieved information or to provide details about its denial. The reply shall be requested in the "reply request" field.. The content of the {MMS-RETRIEVE} message is defined in the table A.6 and of {MMS-RETRIEVE-RPY} in the table A.7. The procedures for the use of the MMS-Message Identifier shall be followed.

Upon receipt of a M_MMS_RETRIEVE-req primitive from the upper layer the M-MMS part of the MMS initiating entity shall send a corresponding {MMS-RETRIEVE} message to the receiving MMS entity. When a MMS entity receives a {MMS-RETRIEVE} message it shall issue a M_MMS_RETRIEVE-ind to the upper layer. Upon completion of the appropriate action the receiver higher layer entity shall issue a M_MMS_RETRIEVE_RPY-req primitive and the MMS entity shall send a corresponding {MMS-RETRIEVE-RPY} message. Upon receipt of a {MMS-RETRIEVE-RPY} message from the receiving MMS entity the initiating MMS entity shall issue a M_MMS_RETRIEVE_RPY-ind primitive to the upper layer.

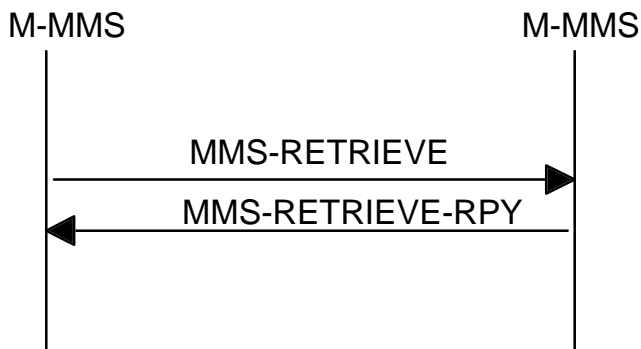

Figure A.4: MMS retrieve procedure options

A.1.3.4.1 {MMS-RETRIEVE} message contents

Table A.6

{MMS-RETRIEVE} IEs	Syntax status	Description
PRIMARY PART		
MMS-Generic-Hdr	M	MMS command and service
Called-Party-Number	O	EE address
Called-Party-Subaddr	O	EE subaddress
Calling-Party-Number	O	initiating entity (PP or MCE) address
Time-Date	O	time & date of various message aspects
MMS-Obj-Hdr	O	user data length and type
MMS-Ext-Hdr	O	service or message specific attributes
Segmented-Info	O	segments of a network layer message
Repeat-Indicator	O	repetition of a particular IE
SECONDARY PART		
MMS-Ext-Hdr	O	service or message specific attributes
Repeat-Indicator	O	repetition of a particular IE

A.1.3.4.2 {MMS-RETRIEVE-RPY} message contents

Table A.7

{MMS-RETRIEVE-RPY} IEs	Syntax status	Description
PRIMARY PART		
MMS-Generic-Hdr	M	MMS command and service
Time-Date	O	time & date of various message aspects
MMS-Obj-Hdr	M	user data length and type
MMS-Ext-Hdr	O	service or message specific attributes
Segmented-Info	O	segments of a network layer message
Repeat-Indicator	O	repetition of a particular IE
SECONDARY PART		
MMS-Ext-Hdr	O	service or message specific attributes
Repeat-Indicator	O	repetition of a particular IE
User Data	O	This IE contains the User Data

NOTE: If the procedure was successful the requested data is in the User data field.

A.1.3.5 MMS RETRIEVE-HDR procedure

The MMS RETRIEVE-H(ead)D(e)R procedure shall be used by an application or MCE to request information from its peer about a message or messages it intends to retrieve, and shall always require a reply, in order to enable the application or MCE to decide upon whether to initiate a MMS-RETRIEVE procedure. The reply shall be requested in the "reply request" field.. The content of the {MMS-RETRIEVE-HDR} message is defined in the table A.8 and of {MMS-RETRIEVE-RPY} in the table A.9. The procedures for the use of the MMS-Message Identifier shall be followed.

Upon receipt of a M_MMS_RETRIEVE_HDR-req primitive from the upper layer the M-MMS part of the MMS initiating entity shall send a corresponding {MMS-RETRIEVE-HDR} message to the receiving MMS entity. When a MMS entity receives a {MMS-RETRIEVE-HDR} message it shall issue a M_MMS_RETRIEVE_HDR-ind to the upper layer. Upon completion of the appropriate action the receiver higher layer entity shall issue a M_MMS_RETRIEVE_RPY-req primitive and the MMS entity shall send a corresponding {MMS-RETRIEVE-RPY} message. Upon receipt of a {MMS-RETRIEVE-RPY} message from the receiving MMS entity the initiating MMS entity shall issue a M_MMS_RETRIEVE_RPY-ind primitive to the upper layer.

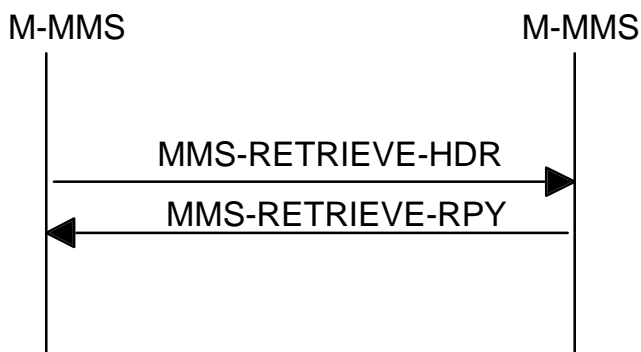

Figure A.5: MMS retrieve procedure options

A.1.3.5.1 {MMS-RETRIEVE-HDR} message contents

Table A.8

{MMS-RETRIEVE-HDR} IEs	Syntax status	Description
PRIMARY PART		
MMS-Generic-Hdr	M	MMS command and service
Called-Party-Number	O	EE address
Called-Party-Subaddr	O	EE subaddress
Calling-Party-Number	O	initiating entity (PP or MCE) address
Time-Date	O	time & date of various message aspects
MMS-Obj-Hdr	O	user data length and type
MMS-Ext-Hdr	O	service or message specific attributes
Segmented-Info	O	segments of a network layer message
Repeat-Indicator	O	repetition of a particular IE
SECONDARY PART		
MMS-Ext-Hdr	O	service or message specific attributes
Repeat-Indicator	O	repetition of a particular IE

A.1.3.5.2 MMS-RETRIEVE-RPY} message contents

Table A.9

{MMS-RETRIEVE-RPY} IEs	Syntax status	Description
PRIMARY PART		
MMS-Generic-Hdr	M	MMS command and service
Time-Date	O	time & date of various message aspects
MMS-Obj-Hdr	M	user data length and type
MMS-Ext-Hdr	O	service or message specific attributes
Segmented-Info	O	segments of a network layer message
Repeat-Indicator	O	repetition of a particular IE
SECONDARY PART		
MMS-Ext-Hdr	O	service or message specific attributes
Repeat-Indicator	O	repetition of a particular IE
User Data	O	This IE contains the User Data

NOTE: If the procedure was successful the requested data is in the User data field.

A.1.3.6 MMS-EXT-CMD procedure

The MMS EXT(ended) C(om)M(an)D procedure is intended to enable the user application to control the management of the messages in the MCE. Functions include MCE Login procedures, the cancellation of a forwarding request and the modification of a directory. The control reply (MMS-EXT-CMD-RPY) is an optional reply requested in the MMS-EXT-CMD message. The content of the {MMS-EXT-CMD} message is defined in the table A.10 and {MMS-EXT-CMD-RPY} in the table A.11.

Upon receipt of M_MMS_EXT_CMD-req primitive from the higher-layer entity MMS entity shall send the {MMS-EXT-CMD} message to the receiving MMS entity. When a MMS entity receives a {MMS-EXT-CMD} message it shall issue a M_MMS_EXT_CMD-ind to the upper layer. Upon receipt of M_MMS_EXT_CMD_RPY-req the MMS entity shall issue a {MMS-EXT-CMD-RPY} message. Upon receipt of the {MMS-EXT-CMD-RPY} the initiating MMS entity shall issue a M_MMS_EXT_CMD_RPY-ind primitive to the higher-layer entity.

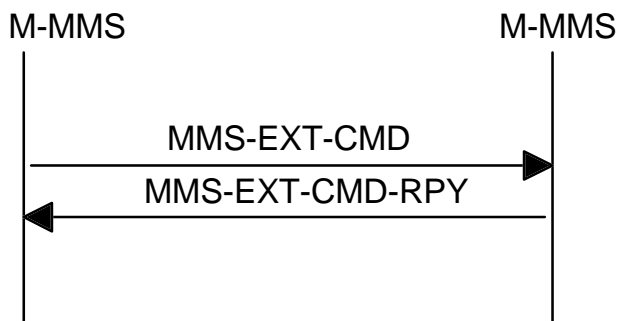

Figure A.6: MMS Command procedure options

A.1.3.6.1 {MMS-EXT-CMD} message contents

Table A.10

{MMS-EXT-CMD} IEs	Syntax status	Description
PRIMARY PART		
MMS-Generic-Hdr	M	MMS command and service
Called-Party-Number	O	EE address
Called-Party-Subaddr	O	EE subaddress
Calling-Party-Number	O	initiating entity (PP or MCE) address
Time-Date	O	time & date of various message aspects
MMS-Obj-Hdr	O	user data length and type
MMS-Ext-Hdr	O	service or message specific attributes
Segmented-Info	O	segments of a network layer message
Repeat-Indicator	O	repetition of a particular IE
SECONDARY PART		
MMS-Ext-Hdr	O	service or message specific attributes
Repeat-Indicator	O	repetition of a particular IE
User Data	O	This IE contains the User Data

A.1.3.6.2 {MMS-EXT-CMD-RPY} message contents

Table A.11

{MMS-EXT-CMD-RPY} IEs	Syntax status	Description
PRIMARY PART		
MMS-Generic-Hdr	M	MMS command and service
Time-Date	O	time & date of various message aspects
MMS-Obj-Hdr	O	user data length and type
MMS-Ext-Hdr	O	service or message specific attributes
Segmented-Info	O	segments of a network layer message
Repeat-Indicator	O	repetition of a particular IE
SECONDARY PART		
MMS-Ext-Hdr	O	service or message specific attributes
Repeat-Indicator	O	repetition of a particular IE
User Data	O	This IE contains the User Data

A.1.3.7 MMS-STATUS procedures

The MMS STATUS procedures are intended to provide the user application with a means to monitor the status of the MCE, with particular emphasis on the status of messages. The {MMS-STATUS} message is used to request status information, typically but not exclusively from the user application to the MCE, whereas the status reply message {MMS-STATUS-RPY} is used for notification of status information, typically but not exclusively to the user application by the MCE. The content of the {MMS-STATUS} message is defined in the table A.12 and {MMS-STATUS-RPY} in the table A.13.

Upon receipt of M_MMS_STATUS-req primitive from the higher-layer entity the MMS initiating entity shall send the {MMS-STATUS} message to the receiving MMS entity. When a MMS entity receives a {MMS-STATUS} message it shall issue a M_MMS_STATUS-ind to the upper layer. Upon receipt of M_MMS_STATUS_RPY-req the receiving MMS entity shall send a {MMS-STATUS-RPY} message. Upon receipt of the {MMS-STATUS-RPY} from the receiving MMS entity the initiating MMS entity shall issue a M_MMS_STATUS_RPY-ind primitive to the higher layer entity.

The higher layer entity may also issue a M_MMS_STATUS_RPY-req primitive at any time in response to a request for a reply from the EE coded in the "reply request" field of the <<MMS-GENERIC-HEADER>> element in an {MMS-SEND} message.

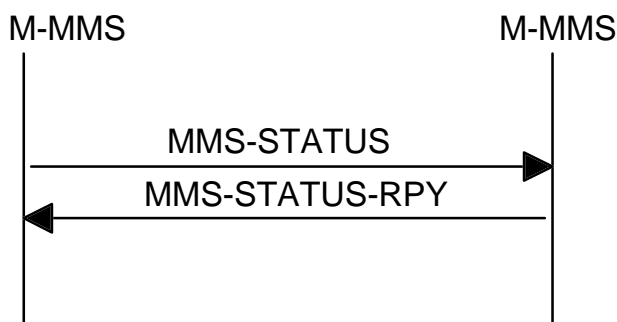

Figure A.7: MMS Status procedure options

A.1.3.7.1 {MMS-STATUS} message contents

Table A.12

{MMS-STATUS} IEs	Syntax status	Description
PRIMARY PART		
MMS-Generic-Hdr	M	MMS command and service
Called-Party-Number	O	EE address
Called-Party-Subaddr	O	EE subaddress
Calling-Party-Number	O	initiating entity (PP or MCE) address
Time-Date	O	time & date of various message aspects
MMS-Obj-Hdr	O	user data length and type
MMS-Ext-Hdr	O	service or message specific attributes
Segmented-Info	O	segments of a network layer message
Repeat-Indicator	O	repetition of a particular IE
SECONDARY PART		
MMS-Ext-Hdr	O	service or message specific attributes
Repeat-Indicator	O	repetition of a particular IE
User Data	O	This IE contains the User Data

A.1.3.7.2 {MMS-STATUS-RPY} message contents

Table A.13

{MMS-STATUS-RPY} IEs	Syntax status	Description
PRIMARY PART		
MMS-Generic-Hdr	M	MMS command and service
Time-Date	O	time & date of various message aspects
MMS-Obj-Hdr	O	user data length and type
MMS-Ext-Hdr	O	service or message specific attributes
Segmented-Info	O	segments of a network layer message
Repeat-Indicator	O	repetition of a particular IE
SECONDARY PART		
MMS-Ext-Hdr	O	service or message specific attributes
Repeat-Indicator	O	repetition of a particular IE
User Data	O	This IE contains the User Data

A.1.3.8 MMS-ESC-CMD procedure

The MMS ESC(ape) C(om)M(an)D procedure is intended to enable the user application to control proprietary functions in the MCE. The control reply (MMS-ESC-CMD-RPY) is an optional reply requested in the MMS-ESC-CMD message. The content of the {MMS-ESC-CMD} message is defined in the table A.14 and {MMS-ESC-CMD-RPY} in the table A.15.

Upon receipt of M_MMS_ESC_CMD-req primitive from the higher-layer entity MMS entity shall send the {MMS-ESC-CMD} message to the receiving MMS entity. When a MMS entity receives a {MMS-ESC-CMD} message it shall issue a M_MMS_ESC_CMD-ind to the upper layer. Upon receipt of M_MMS_ESC_CMD_RPY-req the MMS entity shall issue a {MMS-ESC-CMD-RPY} message. Upon receipt of the {MMS-ESC-CMD-RPY} the initiating MMS entity shall issue a M_MMS_ESC_CMD_RPY-ind primitive to the higher-layer entity.

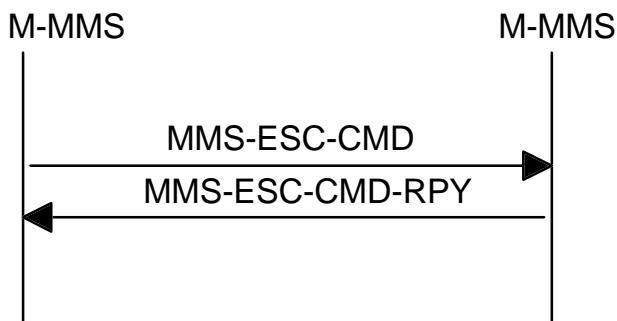

Figure A.8: MMS Command procedure options

A.1.3.8.1 {MMS-ESC-CMD} message contents

Table A.14

{MMS-ESC-CMD} IEs	Syntax status	Description
PRIMARY PART		
MMS-Generic-Hdr	M	MMS command and service
Called-Party-Number	O	EE address
Called-Party-Subaddr	O	EE subaddress
Calling-Party-Number	O	initiating entity (PP or MCE) address
Time-Date	O	time & date of various message aspects
MMS-Obj-Hdr	O	user data length and type
MMS-Ext-Hdr	O	service or message specific attributes
Segmented-Info	O	segments of a network layer message
Repeat-Indicator	O	repetition of a particular IE
SECONDARY PART		
MMS-Ext-Hdr	O	service or message specific attributes
Repeat-Indicator	O	repetition of a particular IE
User Data	O	This IE contains the User Data

A.1.3.8.2 {MMS-ESC-CMD-RPY} message contents

Table A.15

{MMS-ESC-CMD} IEs	Syntax status	Description
PRIMARY PART		
MMS-Generic-Hdr	M	MMS command and service
Time-Date	O	time & date of various message aspects
MMS-OBJ-HDR	O	user data length and type
MMS-Ext-Hdr	O	service or message specific attributes
Segmented-Info	O	segments of a network layer message
Repeat-Indicator	O	repetition of a particular IE
SECONDARY PART		
MMS-Ext-Hdr	O	service or message specific attributes
Repeat-Indicator	O	repetition of a particular IE
User Data	O	This IE contains the User Data

A.1.3.8.3 Generic interworking conventions for the {MMS-ESC-CMD} command and reply

Interworking conventions for the {MMS-ESC-CMD} command and reply messages are outside the scope of this ETS.

A.1.3.9 Procedures for the use of the MMS-message identifier

The "MMS-message identifier" field is set to a value defined by the higher-layer application according to MMS coding rules, and is intended to be used for:

- linking of all parts of one MMS message which are transmitted along different channels by the underlying DECT transport;
- application-layer association between MMS initiating commands and replies.

One MMS command may cause the higher-layer entity to generate more than one reply, but no more than three replies shall be awaiting completion of transmission at once.

The "MMS-message identifier" is coded as shown in annex B, and consists of three subfields: initiate/reply, action ID, and reply sequence number.

The initiate/reply bit shall be set to 0 by the entity that originated the initiating command, and shall be set to 1 by the entity responsible for the reply.

The Action ID shall be set to a locally unique value by the entity that originated the initiating command, and shall be echoed by the entity responsible for the reply.

The reply sequence number shall be set to 00 by the entity that originated the initiating command, and shall be set by the entity responsible for the reply to 00, 01 and 10 cyclically in successive replies to a command defined by a specific Action ID. It shall be set to 11 in the last reply associated with a specific Action ID where the replying entity has this knowledge, otherwise this value shall not be used. Receipt of this value shall be understood by the issuer of the Action ID to mean that the transaction associated with this value is now completed and that the value may now therefore be freely reused. Management of the Action ID if this value is not received is a local management matter.

A.1.3.10 Multi-part message procedures

The multi-part message procedures shall make use of the "multi-part parent message ID" field in the <<MMS-Obj-Hdr>> IE.

The "Multipart Parent Message ID" field is set to a value defined by the higher-layer application, and is intended to be used for application-layer association between different MMS commands and/or replies related to the same multi-part message.

When a higher-layer entity initiates a procedure relating to a multi-part message, it shall select a value for the "Multipart Parent Message ID" and shall use this value in all subsequent commands (including replies) relating to this message.

A.1.3.10.1 Multi-part send procedures

The sending of a multi-part message may optionally commence with a MMS-SEND-REQ procedure, containing the "multi-part parent message ID" and specifying in the <<MMS-Obj-Hdr>> the attributes of the first part of the message. In this case the higher-layer entity shall only proceed to send a multi-part message if in the corresponding {MMS-SEND-RPY} message the <<MMS-Generic-Hdr>> carries the "Command Outcome" field coded to "space allocated". Other codings of this field shall cause the higher-layer entity to not send the message in its proposed dimension. In this case the higher-layer entity may reissue the M_MMS_SEND_REQ-req primitive, at a later time, or with a smaller number of parts or a different data type.

If the higher-layer entity is entitled to proceed with the transmission, each part of the multi-part message shall be sent in a separate {MMS-SEND} message. In the case that the attributes of an object part are different from those of the last part transmitted, higher-layer entity may issue a M_MMS_SEND_REQ-req primitive, using the same multi-part parent message ID as before and in this case shall await a favourable outcome before proceeding to the transmission of the new part.

When the higher-layer entity has completed the transmission of a multi-part message, it shall send a final M_MMS_SEND-req primitive with the <<MMS-Obj-Hdr>> "Src Data Type" field set to "End of Multi-Part message".

A.1.3.10.2 Multi-part retrieve procedures

If a higher layer entity receives a M_MMS_RETRIEVE-req primitive, which refers to a multi-part message, it shall always respond with a M_MMS_RETRIEVE_RPY-req primitive, containing the multi-part parent message ID and the <<MMS-Obj-Hdr>> "Src Data Type" set to "Multi-Part Message". No user data shall be appended to this message. It shall then proceed to transmit the multi-part message to the requesting entity, using the multi-part send procedures and the multi-part parent message ID set to the same value as in the {MMS-RETRIEVE-RPY} message.

A.1.3.11 Unsupported MMS command and IE compatibility procedures

A.1.3.11.1 Unsupported MMS commands procedure

All M-MMS entities shall be capable of receiving all of the MMS commands and responding with the appropriate {MMS-xxxx-RPY} message. If a message is not supported or not supported with the particular Information Elements (IEs) or IE parameters sent with the command then, only if either an EE or MCE reply was requested, the receiving entity shall respond with the appropriate {MMS-xxxx-RPY} message including only the <<MMS-GENERIC-HDR>> IE and indicating:

Command Outcome (octet 6) = Command (and/or Ext. Command) not supported; or
Command Outcome (octet 6) = Unable to carry out Command due to lack of IE support.

The MMS message identifier (and Extended MMS message identifier) shall indicate the same "Action ID" as the received command. The service type and Service Sub-type codings in the reply shall be identical to those in the received command.

A.1.3.11.2 Unsupported Information elements procedure

This is an optional procedure. If supported it shall be implemented as follows:

This procedure applies if an M-MMS entity receives a MMS command which it supports in general, but which included Information Elements (IEs) which it does not support for this particular command. In this case the receiving entity will determine whether it can carry out the command or not and respond appropriately (if requested to do so) indicating the "Command Outcome" in octet 6 of the <<MMS-GENERIC-HDR>> IE. It may then optionally include in this response the "Command Outcome - IE support" codings (octets 6a and 6b) to indicate which IEs of the received command it does not support (within the context of that command only).

A.2 MMSP information elements

Since the C-MMSP has no inherent messages or information elements, this annex describes only the M-MMSP information elements.

A.2.1 Summary of M-MMSP information elements

The definitions of the M-MMSP elements have been intentionally aligned with the mechanism onto which they are mapped, which is the DECT network layer. Therefore, the definitions of some of the information elements are to be found in the DECT base standard, according to the mappings given in annex B.

In the case of MMS-specific information elements however, the codings themselves are contained in this profile, and may be found directly in annex B.

Table A.16: Summary of M-MMSP information elements

PRIMARY PART	Ref.
MMS-Generic-Hdr	B.1.1
Called-Party-Number	B.4.2
Called-Party-Subaddr	B.4.2
Calling-Party-Number	B.4.2
Time-Date	B.4.2
MMS-Obj-Hdr	B.1.2
MMS-Ext-Hdr	B.1.3
Segmented-Info	B.4.2
Repeat-Indicator	B.4.2
SECONDARY PART	
MMS-Ext-Hdr	B.1.3
Repeat-Indicator	B.4.2
User Data	B.4.2

A.3 Parameters of M-MMSP service primitives

The parameters of the M-MMSP service primitives are the means by which the higher layer entity can effectively use the MMS. In practice, these parameters are coded into fields of the M-MMSP information elements listed in clause A.2. The structure of these information elements is identical to the codings in the underlying DECT layer, which are therefore used as the master source for the details of the value codings.

A.3.1 M_MMS_SEND- {req, ind}

Table A.17

Parameter	Allowed values (ref.)	Status
Reply Request	B.1.1	M
MMS-Message Identifier	B.1.1	M
MMS-Message Identifier Extension	B.1.1	O
Service type	B.1.1	M
Service Sub-type	B.1.1	O
Command Outcome	B.1.1	X
User Data Length	B.1.2	M
Source Data Category	B.1.2	M
Destination Data Category	B.1.2	O
Source Data Transfer Category	B.1.2	M
Destination Data Transfer Category	B.1.2	O
Source Data Transfer Encoding	B.1.2	M
Destination Data Transfer Encoding	B.1.2	O
Source Data Type	B.1.2	O
Destination Data Type	B.1.2	O
Multipart Parent Message Identifier	B.1.2	O
Multipart Parent Message Identifier Extension	B.1.2	O
Called Party identity	B.4.2	O
Called Party subaddress	B.4.2	O
Calling Party identity	B.4.2	O
Time/date stamp	B.4.2	O
User Data	B.4.2	O

A.3.2 M_MMS_SEND_REQ- {req, ind}

Table A.18

Parameter	Allowed values (ref.)	Status
Reply Request	B.1.1	M
MMS-Message Identifier	B.1.1	M
MMS-Message Identifier Extension	B.1.1	O
Service type	B.1.1	M
Service Sub-type	B.1.1	O
Command Outcome	B.1.1	X
User Data Length	B.1.2	M
Source Data Category	B.1.2	M
Destination Data Category	B.1.2	O
Source Data Transfer Category	B.1.2	M
Destination Data Transfer Category	B.1.2	O
Source Data Transfer Encoding	B.1.2	M
Destination Data Transfer Encoding	B.1.2	O
Source Data Type	B.1.2	O
Destination Data Type	B.1.2	O
Multipart Parent Message Identifier	B.1.2	O
Multipart Parent Message Identifier Extension	B.1.2	O
Called Party identity	B.4.2	O
Called Party subaddress	B.4.2	O
Calling Party identity	B.4.2	O
Time/date stamp	B.4.2	O

A.3.3 M_MMS_SEND_RPY- {req, ind}

Table A.19

Parameter	Allowed values (ref.)	Status
Reply Request	B.1.1	M
MMS-Message Identifier	B.1.1	M
MMS-Message Identifier Extension	B.1.1	O
Service type	B.1.1	X
Service Sub-type	B.1.1	X
Command Outcome	B.1.1	M
User Data Length	B.1.2	X
Source Data Category	B.1.2	O
Destination Data Category	B.1.2	O
Source Data Transfer Category	B.1.2	O
Destination Data Transfer Category	B.1.2	O
Source Data Transfer Encoding	B.1.2	O
Destination Data Transfer Encoding	B.1.2	O
Source Data Type	B.1.2	O
Destination Data Type	B.1.2	O
Multipart Parent Message Identifier	B.1.2	O
Multipart Parent Message Identifier Extension	B.1.2	O
Called Party identity	B.4.2	X
Called Party subaddress	B.4.2	X
Calling Party identity	B.4.2	X
Time/date stamp	B.4.2	O

A.3.4 M_MMS_RETRIEVE- {req, ind}

Table A.20

Parameter	Allowed values (ref.)	Status
Reply Request	B.1.1	M
MMS-Message Identifier	B.1.1	M
MMS-Message Identifier Extension	B.1.1	O
Service type	B.1.1	M
Service Sub-type	B.1.1	O
Command Outcome	B.1.1	X
User Data Length	B.1.2	O
Source Data Category	B.1.2	O
Destination Data Category	B.1.2	X
Source Data Transfer Category	B.1.2	O
Destination Data Transfer Category	B.1.2	X
Source Data Transfer Encoding	B.1.2	O
Destination Data Transfer Encoding	B.1.2	X
Source Data Type	B.1.2	O
Destination Data Type	B.1.2	X
Multipart Parent Message Identifier	B.1.2	X
Multipart Parent Message Identifier Extension	B.1.2	X
Called Party identity	B.4.2	O
Called Party subaddress	B.4.2	O
Calling Party identity	B.4.2	O
Time/date stamp	B.4.2	O

A.3.5 M_MMS_RETRIEVE_RPY- {req, ind}

Table A.21

Parameter	Allowed values (ref.)	Status
Reply Request	B.1.1	M
MMS-Message Identifier	B.1.1	M
MMS-Message Identifier Extension	B.1.1	O
Service type	B.1.1	X
Service Sub-type	B.1.1	X
Command Outcome	B.1.1	M
User Data Length	B.1.2	M
Source Data Category	B.1.2	M
Destination Data Category	B.1.2	O
Source Data Transfer Category	B.1.2	M
Destination Data Transfer Category	B.1.2	O
Source Data Transfer Encoding	B.1.2	M
Destination Data Transfer Encoding	B.1.2	O
Source Data Type	B.1.2	M
Destination Data Type	B.1.2	O
Multipart Parent Message Identifier	B.1.2	O
Multipart Parent Message Identifier Extension	B.1.2	O
Called Party identity	B.4.2	X
Called Party subaddress	B.4.2	X
Calling Party identity	B.4.2	X
Time/date stamp	B.4.2	O
User Data	B.4.2	O

A.3.6 M_MMS_EXT_CMD- {req, ind}

Table A.22

Parameter	Allowed values (ref.)	Status
Reply Request	B.1.1	M
MMS-Message Identifier	B.1.1	M
MMS-Message Identifier Extension	B.1.1	O
Service type	B.1.1	O
Service Sub-type	B.1.1	O
Command Outcome	B.1.1	X
User Data Length	B.1.2	O
Source Data Category	B.1.2	O
Destination Data Category	B.1.2	X
Source Data Transfer Category	B.1.2	O
Destination Data Transfer Category	B.1.2	X
Source Data Transfer Encoding	B.1.2	O
Destination Data Transfer Encoding	B.1.2	X
Source Data Type	B.1.2	O
Destination Data Type	B.1.2	X
Multipart Parent Message Identifier	B.1.2	O
Multipart Parent Message Identifier Extension	B.1.2	O
Called Party identity	B.4.2	O
Called Party subaddress	B.4.2	O
Calling Party identity	B.4.2	O
Time/date stamp	B.4.2	O
User Data	B.4.2	O

A.3.7 M_MMS_EXT_CMD_RPY- {req, ind}

Table A.23

Parameter	Allowed values (ref.)	Status
Reply Request	B.1.1	M
MMS-Message Identifier	B.1.1	M
MMS-Message Identifier Extension	B.1.1	O
Service type	B.1.1	X
Service Sub-type	B.1.1	X
Command Outcome	B.1.1	M
User Data Length	B.1.2	O
Source Data Category	B.1.2	O
Destination Data Category	B.1.2	X
Source Data Transfer Category	B.1.2	O
Destination Data Transfer Category	B.1.2	X
Source Data Transfer Encoding	B.1.2	O
Destination Data Transfer Encoding	B.1.2	X
Source Data Type	B.1.2	O
Destination Data Type	B.1.2	X
Multipart Parent Message Identifier	B.1.2	O
Multipart Parent Message Identifier Extension	B.1.2	O
Called Party identity	B.4.2	X
Called Party subaddress	B.4.2	X
Calling Party identity	B.4.2	X
Time/date stamp	B.4.2	O
User Data	B.4.2	O

A.3.8 M_MMS_STATUS {req, ind}

Table A.24

Parameter	Allowed values (ref.)	Status
Reply Request	B.1.1	M
MMS-Message Identifier	B.1.1	M
MMS-Message Identifier Extension	B.1.1	O
Service type	B.1.1	O
Service Sub-type	B.1.1	O
Command Outcome	B.1.1	O
User Data Length	B.1.2	O
Source Data Category	B.1.2	O
Destination Data Category	B.1.2	X
Source Data Transfer Category	B.1.2	O
Destination Data Transfer Category	B.1.2	X
Source Data Transfer Encoding	B.1.2	O
Destination Data Transfer Encoding	B.1.2	X
Source Data Type	B.1.2	O
Destination Data Type	B.1.2	X
Multipart Parent Message Identifier	B.1.2	O
Multipart Parent Message Identifier Extension	B.1.2	O
Called Party identity	B.4.2	O
Called Party subaddress	B.4.2	O
Calling Party identity	B.4.2	O
Time/date stamp	B.4.2	O
User Data	B.4.2	O

A.3.9 M_MMS_STATUS_RPY- {req, ind}

Table A.25

Parameter	Allowed values (ref.)	Status
Reply Request	B.1.1	M
MMS-Message Identifier	B.1.1	M
MMS-Message Identifier Extension	B.1.1	O
Service type	B.1.1	X
Service Sub-type	B.1.1	X
Command Outcome	B.1.1	M
User Data Length	B.1.2	O
Source Data Category	B.1.2	O
Destination Data Category	B.1.2	X
Source Data Transfer Category	B.1.2	O
Destination Data Transfer Category	B.1.2	X
Source Data Transfer Encoding	B.1.2	O
Destination Data Transfer Encoding	B.1.2	X
Source Data Type	B.1.2	O
Destination Data Type	B.1.2	X
Multipart Parent Message Identifier	B.1.2	O
Multipart Parent Message Identifier Extension	B.1.2	O
Called Party identity	B.4.2	X
Called Party subaddress	B.4.2	X
Calling Party identity	B.4.2	X
Time/date stamp	B.4.2	O
User Data	B.4.2	O

A.3.10 M_MMS_ESC_CMD- {req, ind}

Table A.26

Parameter	Allowed values (ref.)	Status
Reply Request	B.1.1	M
MMS-Message Identifier	B.1.1	M
MMS-Message Identifier Extension	B.1.1	O
Service type	B.1.1	O
Service Sub-type	B.1.1	O
Command Outcome	B.1.1	X
User Data Length	B.1.2	O
Source Data Category	B.1.2	O
Destination Data Category	B.1.2	O
Source Data Transfer Category	B.1.2	O
Destination Data Transfer Category	B.1.2	O
Source Data Transfer Encoding	B.1.2	O
Destination Data Transfer Encoding	B.1.2	O
Source Data Type	B.1.2	O
Destination Data Type	B.1.2	O
Multipart Parent Message Identifier	B.1.2	O
Multipart Parent Message Identifier Extension	B.1.2	O
Called Party identity	B.4.2	O
Called Party subaddress	B.4.2	O
Calling Party identity	B.4.2	O
Time/date stamp	B.4.2	O
User Data	B.4.2	O

A.3.11 M_MMS_ESC_CMD_RPY- {req, ind}

Table A.27

Parameter	Allowed values (ref.)	Status
Reply Request	B.1.1	M
MMS-Message Identifier	B.1.1	M
MMS-Message Identifier Extension	B.1.1	O
Service type	B.1.1	O
Service Sub-type	B.1.1	O
Command Outcome	B.1.1	M
User Data Length	B.1.2	O
Source Data Category	B.1.2	O
Destination Data Category	B.1.2	O
Source Data Transfer Category	B.1.2	O
Destination Data Transfer Category	B.1.2	O
Source Data Transfer Encoding	B.1.2	O
Destination Data Transfer Encoding	B.1.2	O
Source Data Type	B.1.2	O
Destination Data Type	B.1.2	O
Multipart Parent Message Identifier	B.1.2	O
Multipart Parent Message Identifier Extension	B.1.2	O
Called Party identity	B.4.2	X
Called Party subaddress	B.4.2	X
Calling Party identity	B.4.2	X
Time/date stamp	B.4.2	O
User Data	B.4.2	O

Annex B (normative): Support of MMSP by the DECT lower layers

B.1 Profile-specific information elements

The information elements defined in this annex are identified in ETS 300 175-5 [5] with reference to this profile. The specification of these elements is given below.

B.1.1 MMS Generic Header information element

The <<MMS-GENERIC-HDR>> information element is mandatory for all M-MMS messages. It identifies the type of MMS command or response/reply and enables their association, identifies the MMS service (and sub-service) type(s) and returns the outcome of MMS commands.

Bits

8	7	6	5	4	3	2	1	Octet:
0	<<MMS-GENERIC-HDR>>							1
Length of Contents (L)								2
0/1	MMS Command type					Rpy Req		3
1	Extended MMS Command type							3a
0/1	MMS message identifier							4
1	Extended MMS message identifier							4a
0/1	Service type							5
1	Service Sub-type							5a
0/1	Command Outcome							6
0/1	Command Outcome - IE support							6a
1	Command Outcome - IE support							6b

MMS Command type (octet 3):

Bits	7 6 5 4 3	Meaning
	0 0 0 0 0	MMS-SEND
	0 0 0 1 0	MMS-SEND-REQ
	0 0 0 x 1	MMS-SEND-RPY
	0 0 1 0 0	MMS-RETRIEVE
	0 0 1 1 0	MMS-RETRIEVE-HDR
	0 0 1 x 1	MMS-RECEIVE-RPY
	0 1 0 0 0	MMS-EXT-CMD (Octet 3a shall always be sent with this coding)
	0 1 0 0 1	MMS-EXT-CMD-RPY (Octet 3a shall always be sent with this coding)
	0 1 0 1 0	MMS-STATUS (Octet 3a shall always be sent with this coding)
	0 1 0 1 1	MMS-STATUS-RPY (Octet 3a shall always be sent with this coding)
	0 1 1 0 0	MMS-ESC-CMD (Octet 3a shall always be sent with this coding)
	0 1 1 0 1	MMS-ESC-CMD-RPY (Octet 3a shall always be sent with this coding)

Reply requested (octet 3):

Bits	2 1	Meaning
	x 0	Reply not requested from the MCE
	x 1	Reply requested from the MCE
	0 x	Reply not requested from the EE
	1 x	Reply requested from the EE

Extended MMS Command type (octet 3a):

When used with the MMS Command coding (Octet 3) = MMS-EXT-CMD or MMS-EXT-CMD-RPY this octet shall have the following meaning:

Bits	7 6 5 4 3 2 1	Meaning
Connection Related		
0 0 0 0 0 0 0		Reset MMS connection
0 0 0 1 0 0 0		MCE login
0 0 0 1 0 0 1		MCE logout
0 1 1 1 0 0 0		Retrieve MCE capabilities
0 1 1 1 0 0 1		Retrieve EE capabilities
0 1 1 1 0 1 0		Retrieve current date, time and time-zone
Message Related: transfers and commands		
1 0 0 0 0 0 0		Interrupt MMS message transfer
1 0 0 0 0 0 1		Resume MMS message transfer
1 0 0 0 0 1 0		Cancel MMS command
Message Related: MCE manipulation		
1 0 0 1 0 0 0		Delete message
1 0 0 1 0 0 1		Replace message
1 0 0 1 0 1 0		Retrieve directory contents
1 0 0 1 0 1 1		Change current directory
1 0 0 1 1 0 0		Create new directory
All other values reserved.		

When used with the MMS Command coding (Octet 3) = MMS-STATUS or MMS-STATUS-RPY this octet shall have the following meaning:

Bits	7 6 5 4 3 2 1	Meaning
0 0 0 0 0 0 0		Retrieve message status
0 0 0 0 0 0 1		Retrieve status of all pending messages
0 0 0 0 0 1 0		New message(s) available for retrieval
1 0 0 0 0 0 0		MMS entity has message storage available
1 0 0 0 0 0 1		MMS entity has no message storage available
All other values reserved.		

When used with the MMS Command coding (Octet 3) = MMS-ESC-CMD or MMS-ESC-CMD-RPY this octet shall be used to identify manufacturer specific commands which are not implemented with the standard MMS commands.

MMS message identifier (octet 4) and extended MMS identifier (octet 4a):

8	7	6	5	4	3	2	1
0/1	I/R	Rply seq	Action ID part 1				
1	Action ID part 2 (optional)						

I/R indicates initiate/reply

Rply seq is a reply sequence number. Coded as a natural binary value and the least significant bit is in position 5.

Action ID indicates action identifier.

Service type (octet 5) (Optional):

This octet may be omitted provided octet 5a and 6 are not required. If omitted the receiving entity shall assume a coding of 0 0 0 0 0 0.

Bits	7 6 5 4 3 2 1	Meaning
0 0 0 0 0 0		Unspecified/ not applicable
0 0 0 0 0 1		Any method
0 0 0 0 1 0		Address and Data category and type based IWU selection
0 0 0 0 1 1		A message handling facility
0 0 0 1 0 0		Physical
0 0 0 1 0 0		Voice telephony
0 0 0 1 0 0 1		Telex
0 0 0 1 0 1 0		Teletex
0 0 0 1 0 1 1		Facsimile group 3 (Real-time)
0 0 0 1 1 0 0		Facsimile group 4 (Real-time)
0 0 0 1 0 1 1		Facsimile group 3 (Store and forward)
0 0 0 1 1 0 0		Facsimile group 4 (Store and forward)
0 0 0 1 1 0 1		Videotex (ITU-T Recommendations T.100 [18]/T.101 [19])
0 0 1 0 0 0 0		ERMES
0 0 1 0 0 0 1		National paging
0 0 1 0 0 1 0		UCI (ETS 300 133-3)
0 0 1 0 0 1 1		GSM SMS
0 0 1 0 1 0 0		Native DECT MMS
0 0 1 0 1 1 0		IA5 terminal
0 0 1 0 1 1 1		X.400 message handling
0 1 0 0 0 0 0		FTP
0 1 0 0 0 0 1		World Wide Web (WWW)
0 1 0 0 0 1 0		Gopher
0 1 0 0 0 1 1		News
0 1 0 0 1 0 0		News/NNTP
0 1 0 0 1 0 1		Telnet
0 1 0 0 1 1 0		Wide area info server
0 1 0 0 1 1 1		Host specific file names
1 1 x x x x x		Reserved for proprietary service types
All other values reserved.		

Service Sub-type (octet 5a) (Optional):

This octet is optional. If omitted the receiving entity shall assume a coding of 0 0 0 0 0 0.

Bits	7 6 5 4 3 2 1	Meaning
0 0 0 0 0 0		Default / Undefined

All other codings shall be interpreted uniquely for each service type (octet 5) coding. These codings are given in the interworking specifications for each of the service types. In general this coding is used to select the MCE IWU or a specific functionality within the MMS IWU.

Command outcome (octet 6) (Optional):

This octet shall only be sent if the MMS Command type (octet 3) = MMS-xxxx-RPY.

Bits	7 6 5 4 3 2 1	Meaning
Successful transactions:		
0 0 0 0 0 0 0		Command successfully completed by the MCE
0 0 0 0 0 0 1		Command received by the MCE and pending
0 0 0 0 1 0 0		MMS Send Request (MMS-SEND-REQ) granted
0 0 0 0 1 0 1		MMS Send Request (MMS-SEND-REQ) granted and capability reserved
0 0 0 0 1 1 0		MMS Send Request (MMS-SEND-REQ) granted for default service configuration only.
0 0 0 1 0 0 0		Message received or retrieved by the EE
0 0 0 1 0 0 1		Message sent to the EE
0 0 0 1 0 1 0		Message object header sent to EE
0 0 0 1 0 1 1		Message waiting notified to EE
Temporary Errors:		
0 1 0 0 0 0 0		Congestion
0 1 0 0 0 0 1		EE busy
0 1 0 0 0 1 0		No response from EE
0 1 0 0 0 1 1		Unable to carry out Command due to temporary MCE comms failure
0 1 0 0 1 0 0		Quality of service not available
0 1 0 0 1 0 1		Error in EE
0 1 0 0 1 1 0		No memory available
0 1 0 0 1 1 1		No processing capability available
0 1 0 1 0 0 0		MMS Send Request (MMS-SEND-REQ) not granted, re-send previous MMS Object, if possible
0 1 1 0 0 0 0		No data conversion capability available
Permanent Errors:		
1 0 0 0 0 0 0		Command (and/or Ext. Command) not supported
1 0 0 0 0 0 1		Unable to carry out Command due to lack of IE support
1 0 0 0 0 1 0		Unable to carry out Command due to permanent MCE comms failure
1 0 0 0 1 0 0		Invalid address
1 0 0 0 1 0 1		Invalid network (End User not accessible)
1 0 0 0 1 1 0		Unknown Multipart Parent Message Identifier
1 0 0 1 0 0 0		EE not available
1 0 0 1 0 0 1		EE cannot support MMS Object type
1 0 0 1 1 0 0		Service type not supported
1 0 0 1 1 0 1		Service Sub-type not supported
1 0 1 0 0 0 0		Incompatible file type
1 0 1 0 0 0 1		Data conversion not supported
1 0 1 0 0 1 0		Data conversion failed - source data corrupted
1 0 1 0 0 1 1		Data conversion failed - source data too large

All other values reserved.

Command outcome - IE support (octet 6a) (Optional):

This octet shall only be sent if the MMS Command type (octet 3) = MMS-xxxx-RPY.

These codings are used in a reply to a MMS command and in conjunction with "Command Outcome" (octet 6) to indicate information elements within the MMS command which are not supported by the receiving entity. This octet may be used with any of the "Command Outcome" (octet 6) codings.

Bits	7 6 5 4 3 2 1	Meaning
Primary Part Information Elements (IEs) not supported:		
x x x x x x 1		<<CALLED-PARTY-NUMBER>> IE not supported with this command
x x x x x 1 x		<<CALLED-PARTY-SUBADDR>> IE not supported with this command
x x x x 1 x x		<<CALLING-PARTY-NUMBER>> IE not supported with this command
x x x 1 x x x		<<TIME-DATE>> IE not supported with this command
x x 1 x x x x		<<MMS-OBJ-HDR>> IE not supported with this command
x 1 x x x x x		<<MMS-EXT-HDR>> IE not supported with this command
1 x x x x x x		<<SEGMENTED-INFO>> IE not supported with this command

Command outcome - IE support (octet 6b) (Optional):

This octet shall only be sent if the MMS Command type (octet 3) = MMS-xxxx-RPY.

These codings are used in a reply to a MMS command and in conjunction with "Command Outcome" (octet 6) to indicate information elements within the MMS command which are not supported by the receiving entity. This octet may be used with any of the "Command Outcome" (octet 6) codings.

Bits	7 6 5 4 3 2 1	Meaning
Primary Part Information Elements (IEs) not supported:		
x x x x x 1		<<REPEAT-INDICATOR>> IE not supported with this command
Secondary Part Information Elements (IEs) not supported:		
x x x x 1 x		<<MMS-EXT-HDR>> IE not supported with this command
x x x 1 x x		<<REPEAT-INDICATOR>> IE not supported with this command
x x x 1 x x x		<<USER-DATA>> IE not supported with this command
x x 1 x x x x		Reserved for future IEs not supported with this command
x 1 x x x x x		Reserved for future IEs not supported with this command
1 x x x x x x		Reserved for future IEs not supported with this command

B.1.2 MMS Object Header information element

The <<MMS-OBJ-HDR>> information element is mandatory for all M-MMS messages which contain or describe User Data. The information element describes the source data, its length, optionally destination data and optionally the multipart parent of the message.

Bits								Octet:	
8	7	6	5	4	3	2	1		
0								<<MMS-OBJ-HDR>>	1
Length of Contents (L)								2	
0/1	Resrv.		L desc.		# of L octets			3	
User Data Length Octet 1 (most significant)								3a	
User Data Length Octet 2								3b	
User Data Length Octet 3								3c	
User Data Length Octet 4								3d	
User Data Length Octet 5								3e	
User Data Length Octet 6								3f	
User Data Length Octet 7								3g	
User Data Length Octet 8 (least significant)								3h	
0/1	Src UD Cat.		Source User Data Transfer Encoding					4	
1	Dest UD Cat.		Destination User Data Transfer Encoding					4a	
0/1	Source User Data type							5	
0/1	Extended Source User Data type							5a	
0/1	Destination User Data type							5b	
1	Extended Destination User Data type							5c	
0/1	Multipart parent Message Identifier							6	
1	Multipart parent Extended Message ID							6a	

Reserved (Resrv.) (octet 3):

Bits	7	6	Meaning
x	x		All values reserved.

Length description (L desc.) (octet 3):

Bits	5	4	Meaning
0	0		User data length specified (at least octet 3a shall be included)
0	1		User data length not specified (none of octets 3a-3h shall be included and # of octets coding shall be ignored)
1	0		No user data present (none of octets 3a-3h shall be included and # of octets coding shall be ignored)
1	1		Reserved

Number of length octets (# of octets.) (octet 3):

Bits	3 2 1	Meaning
0 0 0		1 octet (octet 3a only shall be included)
0 0 1		2 octets (octets 3a-3b shall be included)
0 1 0		3 octets (octets 3a-3c shall be included)
0 1 1		4 octets (octets 3a-3d shall be included)
1 0 0		5 octets (octets 3a-3e shall be included)
1 0 1		6 octets (octets 3a-3f shall be included)
1 1 0		7 octets (octets 3a-3g shall be included)
1 1 1		8 octets (octets 3a-3h shall be included)

User data length octets 1 up to 8 (octets 3a up to 3h):

These octets are coded as a natural binary value indicating the number of octets of User Data.

Source user data category (Src UD Cat.) (octet 4):

Bits	7 6	Meaning
0 0		Audio user data
0 1		Image user data
1 0		Video user data
1 1		Other user data

Source user data transfer encoding (octet 4):

Bits	5 4 3 2 1	Meaning
0 0 0 0 0		No transfer encoding
0 0 0 0 1		UUENCODE
0 0 0 1 0		BASE64
0 0 1 0 0		User data compressed using V.42bis
0 0 1 0 1		User data compressed using ZIP
0 1 0 0 0		User data encrypted using PGP
All other values reserved.		

Destination user data category (Dest UD Cat.) (octet 4a):

Bits	7 6	Meaning
0 0		Audio user data
0 1		Image user data
1 0		Video user data
1 1		Other user data

Destination user data transfer encoding (octet 4a):

Bits	5 4 3 2 1	Meaning
0 0 0 0 0		No transfer encoding
0 0 0 0 1		UUENCODE
0 0 0 1 0		BASE64
0 0 1 0 0		User data compressed using V.42bis
0 0 1 0 1		User data compressed using ZIP
0 1 0 0 0		User data encrypted using PGP
All other values reserved.		

Source user data type (octet 5):

Bits	7 6 5 4 3 2 1	Meaning
Single field user data types (octet 5a shall not be included):		
0 0 0 0 0 0 0		User data type unknown
0 0 0 0 0 0 1		Simple formattable document
0 0 0 0 0 1 0		Basic text
0 0 0 0 1 0 0		IA 5 text (ITU-T Recommendation T.50 [17])
0 0 0 0 1 0 1		Telex
0 0 0 0 1 1 0		Teletex
0 0 0 1 0 0 0		Videotex (ITU-T Recommendations T.100 [18]/T.101 [19])
0 0 0 1 0 0 1		TIFF image
0 0 0 1 0 1 0		GIF image
0 0 0 1 0 1 1		JPEG image
0 0 0 1 1 0 0		ITU-T Recommendation T.4 [15] one dimensional coded image
0 0 0 1 1 0 1		ITU-T Recommendation T.4 [15] two dimensional coded image
0 0 0 1 1 1 0		ITU-T Recommendation T.6 [16] coded image
0 0 1 0 0 0 0		32 kbit/s ADPCM coded audio
0 0 1 0 0 0 1		16 kbit/s ADPCM coded audio
0 0 1 0 0 1 0		8 kbit/s ADPCM coded audio
0 0 1 0 0 1 1		AVI audio
0 0 1 0 1 0 0		AU audio
0 1 0 0 0 0 0		Telematic File Transfer (TFT), ITU-T Recommendation T.434 [20]
0 1 0 0 0 0 1		Encapsulated: RFC 822
0 1 0 0 0 1 0		Encapsulated: GSM SMS
0 1 0 0 0 1 1		Encapsulated: X.400
0 1 0 0 1 0 0		Postscript file
0 1 0 0 1 0 1		Extended postscript file
0 1 0 0 1 1 0		MPEG video
0 1 0 0 1 1 1		AVI video
0 1 0 1 0 0 0		MOV video
0 1 1 1 0 0 0		Multipart message parent - multiple messages (no user data shall be included in this MMS message, user data category shall be "Other user data")
0 1 1 1 0 0 1		Multipart message parent -single segmented message (no user data shall be included in this MMS message, user data category shall be "Other user data")
0 1 1 1 1 1 1		Multipart message end (no user data shall be included in this MMS message)

Double field user data types (octet 5a shall be included).

This field is used to define categories:

1 0 0 0 0 0 0	Audio user data
1 0 0 0 0 0 1	Image user data
1 0 0 0 1 0 1	Image, replace previous image, user data
1 0 0 0 0 1 0	Video and audio combined user data
1 0 0 0 1 1 0	Video only user data
1 0 0 1 0 0 0	Operating system file
1 0 0 1 0 0 1	Application file
1 0 0 1 0 1 0	Executable file
1 0 0 1 0 1 1	Unformatted text
1 0 0 1 1 0 0	Formatted text
1 1 1 1 0 0 0	Multipart user data
1 1 1 1 1 1 1	Proprietary user data type

All other values reserved.

Extended source user data type (octet 5a):

Bits 7 6 5 4 3 2 1 Meaning

Codings applicable to all Source user data type codings (octet 5):

0 0 0 0 0 0 0 Not applicable (used with 0 x x x x x codings for octet 5 when octet 5b is included)

Codings applicable only if Source user data type (octet 5) = Audio user data:

0 0 0 0 0 0 1 Unknown audio user data coding
0 0 0 0 0 1 0 PCM 64 kbit/s
0 0 0 0 0 1 1 ADPCM 32 kbit/s
0 0 0 0 1 0 0 ADPCM 16 kbit/s
0 0 0 0 1 0 1 ADPCM 8 kbit/s
0 0 0 0 1 1 0 GSM full rate 13 kbit/s voice coding
0 0 1 0 0 0 0 AU audio coding
0 0 1 0 0 0 1 AVI audio coding
0 0 1 0 0 1 0 CD Music disc audio coding
All other values reserved.

**Codings applicable only if Source user data type (octet 5) =
Image and Image, replace previous image, user data:**

0 0 0 0 0 0 1 Unknown image user data coding
0 0 0 0 0 1 0 GIF
0 0 0 0 0 1 1 TIFF
0 0 0 0 1 0 0 JPEG
0 0 0 0 1 0 1 PCX
0 0 0 0 1 1 0 DCX
All other values reserved.

Codings applicable only if Source user data type (octet 5) =

Video and audio combined user data:

0 0 0 0 0 0 1 Unknown video and audio user data coding
0 0 0 0 0 1 0 MPEG
0 0 0 0 0 1 1 AVI
0 0 0 0 1 0 0 MOV
0 0 0 0 1 0 1 H.320

All other values reserved.

Codings applicable only if Source user data type (octet 5) =

Video only user data:

All other values reserved.

Codings applicable only if Source user data type (octet 5) =

Operating system file user data:

0 0 0 0 0 0 1 MSDOS general file
0 0 0 0 0 1 0 MSDOS system file
0 0 0 0 0 1 1 MSDOS executable file
0 0 0 0 1 0 0 MSDOS directory file
0 0 0 1 0 0 1 Windows 3 general file
0 0 0 1 0 1 0 Windows 3 system file
0 0 0 1 0 1 1 Windows 3 executable file
0 0 0 1 1 0 0 Windows 3 directory file
0 0 1 0 0 0 1 Windows 95 general file
0 0 1 0 0 1 0 Windows 95 system file
0 0 1 0 0 1 1 Windows 95 executable file
0 0 1 0 1 0 0 Windows 95 directory file
0 0 1 1 0 0 1 MAC general file
0 0 1 1 0 1 0 MAC system file
0 0 1 1 0 1 1 MAC executable file
0 0 1 1 1 0 0 MAC directory file
0 1 0 0 0 0 1 UNIX general file
0 1 0 0 0 1 0 UNIX system file
0 1 0 0 0 1 1 UNIX executable file
0 1 0 0 1 0 0 UNIX directory file

All other values reserved.

Codings applicable only if Source user data type (octet 5) =

Application user data:

0 0 0 0 0 0 1 Unknown application user data coding
0 0 0 0 0 1 0 MS Word file
0 0 0 0 0 1 1 MS Excel file
0 0 0 0 1 0 0 MS Access file
0 0 0 0 1 0 1 MS Powerpoint file
0 0 0 0 1 1 0 Lotus Notes file

All other values reserved.

Codings applicable only if Source user data type (octet 5) =

Executable file user data:

0 0 0 0 0 0 1 Unknown executable file user data coding
0 0 0 0 0 1 0 Java applet

All other values reserved.

**Codings applicable only if Source user data type (octet 5) =
Unformatted text user data:**

0 0 0 0 0 0 1 Unknown alphabet unformatted user data
0 0 0 0 0 1 0 IA 5 (ITU-T Recommendation T.50 [17])
0 0 0 0 0 1 1 ASCII
All other values reserved.

**Codings applicable only if Source user data type (octet 5) =
Formatted text user data:**

0 0 0 0 0 0 1 Unknown formatted text user data coding
0 0 0 0 0 1 0 Postscript
0 0 0 0 0 1 1 Extended postscript
All other values reserved.

**Codings applicable only if Source user data type (octet 5) =
Multipart user data:**

All codings, except 0 0 0 0 0 0 0, reserved

**Codings applicable only if Source user data type (octet 5) =
Proprietary user data:**

All codings, except 0 0 0 0 0 0 0, are proprietary.

Destination user data type (octet 5b):

Bits	7 6 5 4 3 2 1	Meaning
	0 0 0 0 0 0 0	Best match to MMS service type and Sub-type (octet 5a shall not be included)

All other values coded as for Source user data type (octet 5).

Extended destination user data type (octet 5c):

Bits	7 6 5 4 3 2 1	Meaning
		All codings as for Extended source user data (octet 5a).

Multipart parent message identifier (octet 6):

This information field is used to associate a message part with its multipart parent.

All codings as for message identifier in subclause A.2.1 (octet).

Multipart parent extended message ID (octet 6a):

This information field is used to associate a message part with its multipart parent.

All codings as for Extended message identifier in subclause B.1.1 (octet a).

B.1.3 MMS Extended Header information element

The <<MMS-EXT-HDR>> information element is optional in all M-MMS messages. It contains information about MMS message attributes which cannot be accommodated in the general MMS IEs. This IE describes attributes which are particular to a specific MMS service or object type which it would not be appropriate or possible to describe in the general MMS headers. For this reason most of the codings are defined in the interworking annexes where the message attributes are used. References to those annexes are provided below.

Bits								
8	7	6	5	4	3	2	1	Octet:
0	<<MMS-EXT-HDR>>							1
Length of Contents (L)								2
0/1	Attribute Cat.			Attribute Identifier				3
1	Extended Attribute Identifier							3a
Message Attribute(s) (octet 1)								4
Message Attribute(s) (octet 2)								5
....								...
Message Attribute(s) (octet L-1 or L-2)								L+2

Attribute Category (octet 3):

Bits	7 6 5	Meaning
0 0 0		Extended MMS Object header
0 0 1		MCE IWU configuration parameters
0 1 0		MMS IWU configuration parameters
0 1 1		Capability parameters
1 0 0		MCE Status parameters
All other values reserved.		

Attribute identifier (octet 3):

All the Attribute identifier codings shall be interpreted uniquely for each Attribute category (octet 3, bits 5-7) coding.

Bits 4 3 2 1 Meaning

Codings applicable only if Attribute category (octet 3, bits 7-5) =

Extended MMS Object header:

0 0 0 0 G.3 Fax object parameters, see subclause C.7.7.1.
0 0 0 1 GSM SMS parameters
0 0 1 0 MIME attributes
0 0 1 1 HTTP attributes
0 1 0 0 G.3 Fax Called Subscriber Identity (CSI), see subclause C.7.7.4.

Codings applicable only if Attribute category (octet 3, bits 7-5) =

MCE IWU configuration parameters:

0 0 0 0 G.3 Fax transmission parameters, see subclause C.7.7.2.

Codings applicable only if Attribute category (octet 3, bits 7-5) =

Capability parameters:

0 0 0 0 G.3 Fax capability parameters, see subclause C.7.7.3.
All other values reserved.

Codings applicable only if Attribute category (octet 3, bits 7-5) =

MCE Status parameters:

0 0 0 0 Number of messages waiting (Octet 4 shall follow).
All other values reserved.

Extended attribute identifier (octet 3a):

This octet is optional. All the Extended object attribute identifier codings shall be interpreted uniquely for each of the Attribute category and Attribute identifier (octet 3) codings. These codings are given in the interworking annexes for the MMS services where these message attributes are used as indicated in the Attribute identifier codings (octet 3, bits 1-4) above.

This field distinguishes among a number of sub-attributes for a given Attribute category and Attribute identifier (octet 3) coding, such as a range of MMS Object, G3 Fax object parameters.

Message attribute(s) (octets 4 to L+2):

These octets are optional. The coding of the message attributes octets shall be interpreted uniquely for each of the Attribute category and Attribute identifier (octet 3) and Extended attribute identifier (octet 3a) codings. These codings are given in the interworking annexes for the MMS services where these message attributes are used as indicated in the Attribute identifier codings (octet 3, bits 1-4) above.

This field describes the MMS message attributes identified by octets 3 and 3a.

B.2 LAPU Frame Format applicable for the F profile

F profile uses the LAPU frame format for transfer of user data and some other information where high bandwidth capacity is needed. This clause specifies the formatting rules for LAPU usage.

B.2.1 The information field in case of SAPI 0

This information field is used to carry user data.

Information element	Reference	Status	Length octets
Message identifier (note 1)		M	1-2
User data (note 2)		O	1-*
NOTE 1: Copy of the MMS message identifier in MMS GENERIC HEADER information field of the M-MMS message.			
NOTE 2: Copy of user data information element in the secondary part of MMS-SEND message and MMS-RETRIEVE-RPY.			

B.2.2 The information field in case of SAPI 3

This information field is used to carry all information fields of the secondary part other than user data.

Information element	Reference	Status	Length octets
Message identifier (note 1)		M	1-2
MMS-EXT-HDR (note 2)		O	1-*
Repeat Indicator (note 2)		O	1
NOTE 1: Copy of the MMS message identifier in MMS GENERIC HEADER information field of the M-MMS message.			
NOTE 2: Copy of corresponding information element in the secondary part of any M-MMS message.			

B.3 C-MMS primitive mapping rules

There is no concept of "C-MMS messages". Therefore C-MMS primitives are directly mapped to MNCC primitives.

The mapping shall be as follows as follows:

MMS primitive	MNCC primitive
C_MMS_SETUP- {req, ind}	MNCC_SETUP- {req, ind}
C_MMS_CONNECT- {req, cfm, ind}	MNCC_CONNECT- {req, cfm, ind}
C_MMS_RELEASE- {req, cfm, ind, res}	MNCC_RELEASE- {req, cfm, ind, res}
C_MMS_MODIFY- {req, cfm, ind}	MNCC_MODIFY- {req, cfm, ind}

The parameters of corresponding primitives are identical.

B.4 M-MMS message mapping rules

B.4.1 General

In both F2 and E2 profiles the primary part of an M-MMS message is placed into an IWU-INFO message.

In the case of the F2 profile the complete secondary part of the M-MMS message is placed into a LAPU frame.

In the case of the E2 profile the User data field of the secondary is carried in the IWU-INFO message. Other fields of the secondary part are not conveyed.

B.4.2 Information Element Mapping Rules

The following M-MMS information elements are mapped one to one on to elements with the same name in the network layer.

M-MMS information element	Reference
MMS-Generic-Header	This profile, B.1.1
Called-Party-Number	ETS 300 175-5 [5], 7.7.7.
Called Party Subaddress	ETS 300 175-5 [5], 7.7.8.
Calling Party Number	ETS 300 175-5 [5], 7.7.9.
Time-Date	ETS 300 175-5 [5], 7.7.50
MMS-Obj-Header	This profile, B.1.2
MMS-Ext-Header	This profile, B.1.3
Segmented Info	ETS 300 175-5 [5], 7.7.37.
Repeat Indicator	ETS 300 175-5 [5], 7.6.3

In case of the E2 profile the M-MMS user data information element is mapped into the NWK IWU-to-IWU information elements as follows:

M-MMS information element	NWK information element	Reference
User data	IWU-TO-IWU with <protocol discriminator> M-MMS, user data is mapped into the IWU-TO-IWU-INFORMATION field	ETS 300 175-5 [5], 7.7.23

In case of the F2 profile the M-MMS user data information element is mapped on the LAPU user data information element as specified in subclause B.2.1.

Annex C (normative): Interworking conventions for real-time facsimile group 3 (MMS to T.30 G3 interworking)

C.1 Introduction and scope of annex

This annex specifies the interworking conventions between the MMS specified in the main body of this ETS and the real-time T.30 Group 3 facsimile (G3 fax) procedures and messages.

In the context of this annex "real-time" refers to the direct time correspondence that exists regarding the call states and message transfer states between the PP and FP and the MMS IWU and the MCE/EE fax terminal equipment. This is in contrast to the Store and Forward Fax service where no such time relationship is specified.

This annex specifies interworking for all aspects of the G3 fax binary coded signalling specified in T.30 excluding G3 fax transmission on the ISDN (ITU-T Recommendation T.30 [14], annex C) but including optional procedures such as Error Correction Mode (ECM) and Binary File Transfer (BFT).

Interworking to Group 1 and 2 facsimile apparatus is outside the scope of this interworking annex. Interworking to with the fax tonal signalling procedures specified in ITU-T Recommendation T.30 [14] is also outside the scope of this ETS.

This interworking annex does not preclude the use in the MMS IWU of a manufacturer's proprietary non-standard facilities T.30 procedures (as explicitly catered for in ITU-T Recommendation T.30 [14]) provided that these can be interworked to the MMS messages in such a way as to provide interoperability with the standard PP operating in accordance with this interworking annex.

C.2 Definition of the services and features

The MMS messages, information elements and procedures specified in this annex provide interworking to the following G3 real-time fax services:

1 Outgoing (FP to PP) fax service:

- 1.1 STD: Basic Telefax G3 Service (ITU-T Recommendation T.4 [15]) [default].
- 1.2 BFT: Telematic File Transfer (TFT) of Telefax G3 service: Binary file transfer [optional].
- 1.3 DTM: Telematic File Transfer (TFT) of Telefax G3 service: Document transparent mode [optional].
- 1.4 EDI: Telematic File Transfer (TFT) of Telefax G3 Service: Edifact [optional].
- 1.5 BTM: Telematic File Transfer (TFT) of Telefax G3 Service: Basic transparent mode [optional].

All DECT equipment claiming conformance with the Outgoing Fax service as specified in this interworking annex shall implement at a minimum the MMS messages, information elements and procedures for the "default" Outgoing Fax service.

2 Incoming (PP to FP) Fax service:

- 2.1 STD: basic Telefax G3 service (ITU-T Recommendation T.4 [15]) [default].
- 2.2 BFT: Telematic File Transfer (TFT) of Telefax G3 service: Binary file transfer [optional].
- 2.3 DTM: Telematic File Transfer (TFT) of Telefax G3 service: Document transparent mode [optional].
- 2.4 EDI: Telematic File Transfer (TFT) of Telefax G3 service: edifact [optional].
- 2.5 BTM: Telematic File Transfer (TFT) of Telefax G3 service: Basic transparent mode [optional].

All DECT equipment claiming conformance with the Incoming Fax service as specified in this interworking annex shall implement at a minimum the MMS messages, information elements and procedures for the "default" incoming facsimile service.

In addition to the above fax services this interworking annex also enables a number of optional features which can be used in conjunction with each of the above services. The message and information element coding and procedures for these features is fully specified in such a way so as to avoid problems with interoperability. The features are listed as follows:

- O.1 Full control of all T.30 parameters on a fax message (note 1) by fax message basis;
- O.2 Outgoing Fax via fax polling (i.e. via a FP initiated incoming call);
- O.3 Incoming Fax via fax polling (i.e. via a PP initiated outgoing call);
- O.4 Support for T.30 Error Correction Mode (ECM) (note 2).

It may be noted that, as defined in ITU-T Recommendation T.30 [14], Option O.4 is required to support any of the above defined services other than the basic Telefax G3 service (STD).

NOTE 1: ITU-T Recommendation T.30 [14] defines a (fax) "message" as a sequence of one or more ITU-T Recommendation T.4 [15] pages (or TFT files) of the same type (i.e. same DCS fax session parameters). Within ITU-T Recommendation T.30 [14] this is also sometimes referred to as a document. In the context of this interworking annex this is called a level 2 MMS fax message, see subclause C.8.1.1.

NOTE 2: Support for this feature does not require any additional functionality in the DECT PP or any additional support for MMS protocol elements or procedures (since the MMS transport mechanism is fully error corrected) but requires only that the MMS IWU in the FP supports this ITU-T Recommendation T.30 [14] optional feature.

C.3 Overview of the MMS requirements

The following subclauses define the MMS messages, information elements and procedures which are required to implement the above services and optional features.

C.3.1 Standardized symbols for the status columns

The standardized symbols for the status column which apply throughout this annex are as follows:

- m or M for mandatory (the capability is required to be implemented);
- o or O for optional (Boolean) (the capability may be implemented);
- x or X for prohibited or excluded use (the capability may not be used in a given context);
- n/a, N/A or - (dash) for not applicable (the capability is not allowed because the underlying MMS messages, information elements, or IE fields cannot handle it);
- c or C for conditional (the capability depends on the selection of other optional or/and conditional items);
- i or I for out of scope (the capability is allowed to be implemented but is not called upon by the profile functionality).

If appropriate, a "C" followed by an integer is placed in the status column, providing a reference to a conditional status expression. The following conditions are applicable throughout this annex:

Condition identifier	Condition definition
<i>Outgoing Fax service</i>	
C1.1	"M" if Option O.1 is supported; "I" if this option is not supported. See clause C.2.
C1.1o	"O" if Option O.1 is supported; "X" if this option is not supported. See clause C.2.
C1.1m	"M" if Option O.1 is supported; "X" if this option is not supported. See clause C.2.
C1.2	"M" if Option O.2 is supported; "I" if this option is not supported. See clause C.2.
C1.2m	"M" if Option O.2 is supported; "X" if this option is not supported. See clause C.2.
<i>Incoming Fax service</i>	
C2.1	"M" if Option O.1 is supported; "I" if this option is not supported. See clause C.2.
C2.1o	"O" if Option O.1 is supported; "X" if this option is not supported. See clause C.2.
C2.1m	"M" if Option O.1 is supported; "X" if this option is not supported. See clause C.2.
C2.2	"M" if Option O.3 is supported; "I" if this option is not supported. See clause C.2.
C2.2m	"M" if Option O.3 is supported; "X" if this option is not supported. See clause C.2.

C.3.2 Outgoing Fax service

C.3.2.1 C-MMS requirements

As defined in subclause 5.4.2.3, the C-MMS part shall use the normal DECT Call Control procedures for call establishment, suspension, resumption and release. Thus the C-MMS is the same as the DECT Call control entity.

The requirements for the C-MMS messages, information elements and procedures are fully defined in clause 9 of this ETS by reference to the C.2 data service profile (ETS 300 651 [13]). These requirements specify the use of either GAP-like call control procedures or Packet Mode procedures depending on whether call progress information and/or digit by digit dialling are required.

Regardless of which procedures are used the <<IWU-ATTRIBUTES>> information element shall be included with the Coding Standard (octet 3, bits 6-7) = "Profile defined coding" and the Profile (octet 3 bits 1-5) = "F data profile". The remainder of the <<IWU-ATTRIBUTES>> octets shall be coded as specified in subclause C.7.1.

C.3.2.2 M-MMS command requirements

Table C.1 defines the overall status of each of the MMS commands for the Outgoing Fax service.

Table C.1: Status of M-MMS messages

Message	Outgoing Command (PP > FP)		Incoming Command (FP > PP)	
	PP Tx	FP Rx	FP Tx	PP Rx
MMS-SEND	M	M	I	I
MMS-SEND-REQ	M	M	I	I
MMS-SEND-RPY	I	I	M	M
MMS-RETRIEVE	I	I	C1.2	C1.2
MMS-RETRIEVE-HDR	I	I	I	I
MMS-RETRIEVE-RPY	C1.2	C1.2	I	I
MMS-EXT-CMD	C1.1	M	C1.2	C1.2
MMS-EXT-CMD-RPY	C1.2	C1.2	M	C1.1
MMS-STATUS	C1.2	C1.2	I	I
MMS-STATUS-RPY	I	I	I	I
MMS-ESC-CMD	I	I	I	I
MMS-ESC-CMD-RPY	I	I	I	I

C.3.2.3 M-MMS information element requirements

Table C.2 defines the status of the overall level of support which is required for each of the information elements (IEs) for this interworking service.

Table C.2: Overall status of support for M-MMS information elements

MMS IEs	Outgoing Command (PP > FP)		Incoming Command (FP > PP)		Ref.
	PP Tx	FP Rx	FP Tx	PP Rx	
PRIMARY PART					
MMS-Generic-Hdr	M	M	M	M	C.7.2
Called-Party-Number	M	M	I	I	C.7.3
Called-Party-Subaddr	O	O	I	I	C.7.4
Calling-Party-Number	O	O	I	I	C.7.5
Time-Date	I	I	I	I	-
MMS-Obj-Hdr	M	M	M	M	C.7.6
MMS-Ext-Hdr	C1.1	C1.1	C1.1	C1.1	C.7.7
Segmented-Info	C1.1	C1.1	C1.1	C1.1	ETS 300 175-5 [5], 7.7.37
Repeat-Indicator	C1.1	C1.1	C1.1	C1.1	ETS 300 175-5 [5], 7.6.3
SECONDARY PART					
MMS-Ext-Hdr	I	I	I	I	-
Repeat-Indicator	I	I	I	I	-
User Data	M	M	I	I	C.7.8

C.3.3 Incoming Fax service

C.3.3.1 C-MMS requirements

The requirements on the C-MMS for the Incoming Fax service are identical to the outgoing fax service and are defined in subclause C.3.2.1.

C.3.3.2 M-MMS command requirements

Table C.3 defines the overall status of each of the MMS commands for the Incoming Fax service.

Table C.3: Status of M-MMS messages

Message	Outgoing Command (PP > FP)		Incoming Command (FP > PP)	
	PP Tx	FP Rx	FP Tx	PP Rx
MMS-SEND	I	I	M	M
MMS-SEND-REQ	I	I	M	M
MMS-SEND-RPY	M	M	I	I
MMS-RETRIEVE	C2.2	C2.2	I	I
MMS-RETRIEVE-HDR	I	I	I	I
MMS-RETRIEVE-RPY	I	I	C2.2	C2.2
MMS-EXT-CMD	C2.2	C2.2	M	C2.1
MMS-EXT-CMD-RPY	C2.1	M	C2.2	C2.2
MMS-STATUS	I	I	C2.2	C2.2
MMS-STATUS-RPY	I	I	I	I
MMS-ESC-CMD	I	I	I	I
MMS-ESC-CMD-RPY	I	I	I	I

C.3.3.3 M-MMS information element requirements

Table C.4 defines the status of the overall level of support which is required for each of the information elements (IEs) for this interworking service.

Table C.4: Overall status of support for M-MMS information elements

MMS IEs	Outgoing Command (PP > FP)		Incoming Command (FP > PP)		Ref.
	PP Tx	FP Rx	FP Tx	PP Rx	
PRIMARY PART					
MMS-Generic-Hdr	M	M	M	M	C.7.2
Called-Party-Number	I	I	O	O	C.7.3
Called-Party-Subaddr	I	I	O	O	C.7.4
Calling-Party-Number	I	I	O	O	C.7.5
Time-Date	I	I	I	I	-
MMS-Obj-Hdr	M	M	M	M	C.7.6
MMS-Ext-Hdr	C2.1	C2.1	C2.1	C2.1	C.7.7
Segmented-Info	C2.1	C2.1	C2.1	C2.1	ETS 300 175-5 [5], 7.7.37
Repeat-Indicator	C2.1	C2.1	C2.1	C2.1	ETS 300 175-5 [5], 7.6.3
SECONDARY PART					
MMS-Ext-Hdr	I	I	I	I	-
Repeat-Indicator	I	I	I	I	-
User Data	I	I	M	M	C.7.8

C.4 M-MMS message IE requirements - Outgoing Fax service

The following subclauses define the status of each of the MMS Information Elements (IEs) for each of the MMS messages which are required to implement the Outgoing Fax services in this annex.

C.4.1 MMS-SEND command

Table C.5: Status of MMS-SEND command information elements

MMS IEs	Outgoing Command (PP > FP)		Incoming Command (FP > PP)		Ref.
	PP Tx	FP Rx	FP Tx	PP Rx	
<i>PRIMARY PART</i>					
MMS-Generic-Hdr	M	M			C.7.2
Called-Party-Number	C1.1o	M			C.7.3
Called-Party-Subaddr	C1.1o	M			C.7.4
Calling-Party-Number	C1.1o	M			C.7.5
Time-Date	X				-
MMS-Obj-Hdr	M	M			C.7.6
MMS-Ext-Hdr	C1.1m	M			C.7.7
Segmented-Info	C1.1m	M			ETS 300 175-5 [5], 7.7.37
Repeat-Indicator	C1.1m	M			ETS 300 175-5 [5], 7.6.3
<i>SECONDARY PART</i>					
MMS-Ext-Hdr	X				-
Repeat-Indicator	X				-
User Data	M	M			C.7.8

C.4.2 MMS-SEND-REQ command

Table C.6: Status of MMS-SEND-REQ command information elements

MMS IEs	Outgoing Command (PP > FP)		Incoming Command (FP > PP)		Ref.
	PP Tx	FP Rx	FP Tx	PP Rx	
<i>PRIMARY PART</i>					
MMS-Generic-Hdr	M	M			C.7.2
Called-Party-Number	C1.1o	M			C.7.3
Called-Party-Subaddr	C1.1o	M			C.7.4
Calling-Party-Number	C1.1o	M			C.7.5
Time-Date	X				-
MMS-Obj-Hdr	M	M			C.7.6
MMS-Ext-Hdr	C1.1m	M			C.7.7
Segmented-Info	C1.1m	M			ETS 300 175-5 [5], 7.7.37
Repeat-Indicator	C1.1m	M			ETS 300 175-5 [5], 7.6.3
<i>SECONDARY PART</i>					
MMS-Ext-Hdr	X				-
Repeat-Indicator	X				-

C.4.3 MMS-SEND-RPY command

Table C.7: Status of MMS-SEND-RPY command information elements

MMS IEs	Outgoing Command (PP > FP)		Incoming Command (FP > PP)		Ref.
	PP Tx	FP Rx	FP Tx	PP Rx	
<i>PRIMARY PART</i>					
MMS-Generic-Hdr			M	M	C.7.2
Time-Date			X		-
MMS-Obj-Hdr			M	C1.1	C.7.6
MMS-Ext-Hdr			M	C1.1	C.7.7
Segmented-Info			X		-
Repeat-Indicator			M	C1.1	ETS 300 175-5 [5], 7.6.3
<i>SECONDARY PART</i>					
MMS-Ext-Hdr			X		-
Repeat-Indicator			X		-

C.4.4 MMS-RETRIEVE command

Table C.8: Status of MMS-RETRIEVE command information elements

MMS IEs	Outgoing Command (PP > FP)		Incoming Command (FP > PP)		Ref.
	PP Tx	FP Rx	FP Tx	PP Rx	
<i>PRIMARY PART</i>					
MMS-Generic-Hdr			C1.2m	C1.2	C.7.2
Called-Party-Number			C1.1o	C1.1	C.7.3
Called-Party-Subaddr			C1.1o	C1.1	C.7.4
Calling-Party-Number			C1.1o	C1.1	C.7.5
Time-Date			X		-
MMS-Obj-Hdr			X		-
MMS-Ext-Hdr			M	C1.1	C.7.7
Segmented-Info			M	C1.1	ETS 300 175-5 [5], 7.7.37
Repeat-Indicator			M	C1.1	ETS 300 175-5 [5], 7.6.3
<i>SECONDARY PART</i>					
MMS-Ext-Hdr			X		-
Repeat-Indicator			X		-

C.4.5 MMS-RETRIEVE-RPY command

Table C.9: Status of MMS-RETRIEVE-RPY command information elements

MMS IEs	Outgoing Command (PP > FP)		Incoming Command (FP > PP)		Ref.
	PP Tx	FP Rx	FP Tx	PP Rx	
<i>PRIMARY PART</i>					
MMS-Generic-Hdr	C1.2m	C1.2			C.7.2
Time-Date	X				-
MMS-Obj-Hdr	C1.2m	C1.2			C.7.6
MMS-Ext-Hdr	C1.1m	C1.2			C.7.7
Segmented-Info	C1.1m	C1.2			ETS 300 175-5 [5], 7.7.37
Repeat-Indicator	C1.1m	C1.2			ETS 300 175-5 [5], 7.6.3
<i>SECONDARY PART</i>					
MMS-Ext-Hdr	X				-
Repeat-Indicator	X				-
User Data	X				-

C.4.6 MMS-EXT-CMD command

For the purposes of this interworking annex all {MMS-EXT-CMD} messages, except Extended MMS Command type (octet 3a, <<MMS-GENERIC-HDR>> = Retrieve EE capabilities, are "Out of Scope" ("I").

The information elements of the {MMS-EXT-CMD} message with:
Ext. MMS Command type (octet 3a, <<MMS-GENERIC-HDR>> = Retrieve EE capabilities shall have the following status:

Table C.10: Status of MMS-EXT-CMD(Rtrv-Cap) command information elements

MMS IEs	Outgoing Command (PP > FP)		Incoming Command (FP > PP)		Ref.
	PP Tx	FP Rx	FP Tx	PP Rx	
<i>PRIMARY PART</i>					
MMS-Generic-Hdr	C1.1m	M	C1.2m	C1.2	C.7.2
Called-Party-Number	X	I	X	I	-
Called-Party-Subaddr	X	I	X	I	-
Calling-Party-Number	X	I	X	I	-
Time-Date	X	I	X	I	-
MMS-Obj-Hdr	X	I	X	I	-
MMS-Ext-Hdr	X	I	X	I	-
Segmented-Info	X	I	X	I	-
Repeat-Indicator	X	I	X	I	-
<i>SECONDARY PART</i>					
MMS-Ext-Hdr	X	I	X	I	-
Repeat-Indicator	X	I	X	I	-
User Data	X	I	X	I	-

C.4.7 MMS-EXT-CMD-RPY command

For the purposes of this interworking annex all {MMS-EXT-CMD-RPY} messages, except Extended MMS Command type (octet 3a, <<MMS-GENERIC-HDR>> = Retrieve EE capabilities, are "Out of Scope" ("I").

The information elements of the {MMS-EXT-CMD-RPY} message with:
Ext. MMS Command type (octet 3a, <<MMS-GENERIC-HDR>> = Retrieve EE capabilities shall have the following status:

Table C.11: Status of MMS-EXT-CMD-RPY(Rtrv-Cap) command information elements

MMS IEs	Outgoing Command (PP > FP)		Incoming Command (FP > PP)		Ref.
	PP Tx	FP Rx	FP Tx	PP Rx	
<i>PRIMARY PART</i>					
MMS-Generic-Hdr	C1.2m	C1.2	M	C1.1	C.7.2
Time-Date	X	I	X	I	-
MMS-Obj-Hdr	X	I	X	I	-
MMS-Ext-Hdr	C1.2m	C1.2	M	C1.1	C.7.7
Segmented-Info	C1.2m	C1.2	M	C1.1	ETS 300 175-5 [5], 7.7.37
Repeat-Indicator	C1.2m	C1.2	M	C1.1	ETS 300 175-5 [5], 7.6.3
<i>SECONDARY PART</i>					
MMS-Ext-Hdr	X	I	X	I	-
Repeat-Indicator	X	I	X	I	-
User Data	X	I	X	I	-

C.4.8 MMS-STATUS command

Table C.12: Status of MMS-STATUS command information elements

MMS IEs	Outgoing Command (PP > FP)		Incoming Command (FP > PP)		Ref.
	PP Tx	FP Rx	FP Tx	PP Rx	
<i>PRIMARY PART</i>					
MMS-Generic-Hdr	C1.2m	C1.2			C.7.2
Called-Party-Number	X				-
Called-Party-Subaddr	X				-
Calling-Party-Number	X				-
Time-Date	X				-
MMS-Obj-Hdr	X				-
MMS-Ext-Hdr	X				-
Segmented-Info	X				-
Repeat-Indicator	X				-
<i>SECONDARY PART</i>					
MMS-Ext-Hdr	X				-
Repeat-Indicator	X				-
User Data	X				-

C.5 M-MMS message IE requirements - Incoming Fax service

The following subclauses define the status of each of the MMS Information Elements (IEs) for each of the MMS messages which are required to implement the Incoming Fax services in this annex.

C.5.1 MMS-SEND command

Table C.13: Status of MMS-SEND command information elements

MMS IEs	Outgoing Command (PP > FP)		Incoming Command (FP > PP)		Ref.
	PP Tx	FP Rx	FP Tx	PP Rx	
<i>PRIMARY PART</i>					
MMS-Generic-Hdr			M	M	C.7.2
Called-Party-Number			O	C2.1	C.7.3
Called-Party-Subaddr			O	C2.1	C.7.4
Calling-Party-Number			O	C2.1	C.7.5
Time-Date			X		-
MMS-Obj-Hdr			M	M	C.7.6
MMS-Ext-Hdr			M	C2.1	C.7.7
Segmented-Info			M	C2.1	ETS 300 175-5 [5], 7.7.37
Repeat-Indicator			M	C2.1	ETS 300 175-5 [5], 7.6.3
<i>SECONDARY PART</i>					
MMS-Ext-Hdr			X		-
Repeat-Indicator			X		-
User Data			M	M	C.7.8

C.5.2 MMS-SEND-REQ command

Table C.14: Status of MMS-SEND-REQ command information elements

MMS IEs	Outgoing Command (PP > FP)		Incoming Command (FP > PP)		Ref.
	PP Tx	FP Rx	FP Tx	PP Rx	
<i>PRIMARY PART</i>					
MMS-Generic-Hdr			M	M	C.7.2
Called-Party-Number			O	C2.1	C.7.3
Called-Party-Subaddr			O	C2.1	C.7.4
Calling-Party-Number			O	C2.1	C.7.5
Time-Date			X		-
MMS-Obj-Hdr			M	M	C.7.6
MMS-Ext-Hdr			M	C2.1	C.7.7
Segmented-Info			M	C2.1	ETS 300 175-5 [5], 7.7.37
Repeat-Indicator			M	C2.1	ETS 300 175-5 [5], 7.6.3
<i>SECONDARY PART</i>					
MMS-Ext-Hdr			X		-
Repeat-Indicator			X		-

C.5.3 MMS-SEND-RPY command

Table C.15: Status of MMS-SEND-RPY command information elements

MMS IEs	Outgoing Command (PP > FP)		Incoming Command (FP > PP)		Ref.
	PP Tx	FP Rx	FP Tx	PP Rx	
<i>PRIMARY PART</i>					
MMS-Generic-Hdr	M	M			C.7.2
Time-Date	X				-
MMS-Obj-Hdr	X				-
MMS-Ext-Hdr	X				-
Segmented-Info	X				-
Repeat-Indicator	X				-
<i>SECONDARY PART</i>					
MMS-Ext-Hdr	X				-
Repeat-Indicator	X				-

C.5.4 MMS-RETRIEVE command

Table C.16: Status of MMS-RETRIEVE command information elements

MMS IEs	Outgoing Command (PP > FP)		Incoming Command (FP > PP)		Ref.
	PP Tx	FP Rx	FP Tx	PP Rx	
<i>PRIMARY PART</i>					
MMS-Generic-Hdr	C2.2m	C2.2			C.7.2
Called-Party-Number	C2.1o	C2.2			C.7.3
Called-Party-Subaddr	C2.1o	C2.2			C.7.4
Calling-Party-Number	C2.1o	C2.2			C.7.5
Time-Date	X				-
MMS-Obj-Hdr	X				-
MMS-Ext-Hdr	C2.1m	C2.2			C.7.7
Segmented-Info	C2.1m	C2.2			ETS 300 175-5 [5], 7.7.37
Repeat-Indicator	C2.1m	C2.2			ETS 300 175-5 [5], 7.6.3
<i>SECONDARY PART</i>					
MMS-Ext-Hdr	X				-
Repeat-Indicator	X				-

C.5.5 MMS-RETRIEVE-RPY command

Table C.17: Status of MMS-RETRIEVE-RPY command information elements

MMS IEs	Outgoing Command (PP > FP)		Incoming Command (FP > PP)		Ref.
	PP Tx	FP Rx	FP Tx	PP Rx	
<i>PRIMARY PART</i>					
MMS-Generic-Hdr			C2.2m	C2.2	C.7.2
Time-Date			X		-
MMS-Obj-Hdr			C2.2m	C2.2	C.7.6
MMS-Ext-Hdr			C2.2m	C2.1	C.7.7
Segmented-Info			C2.2m	C2.1	ETS 300 175-5 [5], 7.7.37
Repeat-Indicator			C2.2m	C2.1	ETS 300 175-5 [5], 7.6.3
<i>SECONDARY PART</i>					
MMS-Ext-Hdr			X		-
Repeat-Indicator			X		-
User Data			X		-

C.5.6 MMS-EXT-CMD command

For the purposes of this interworking annex all {MMS-EXT-CMD} messages, except Extended MMS Command type (octet 3a, <<MMS-GENERIC-HDR>> = Retrieve EE capabilities, are "Out of Scope" ("I").

The information elements of the {MMS-EXT-CMD} message with:

Ext. MMS Command type (octet 3a, <<MMS-GENERIC-HDR>> = Retrieve EE capabilities shall have the status as given in table C.18.

Table C.18: Status of MMS-EXT-CMD(Rtrv-Cap) command information elements

MMS IEs	Outgoing Command (PP > FP)		Incoming Command (FP > PP)		Ref.
	PP Tx	FP Rx	FP Tx	PP Rx	
<i>PRIMARY PART</i>					
MMS-Generic-Hdr	C2.2m	C2.2	M	C2.1	C.7.2
Called-Party-Number	X	I	X	I	-
Called-Party-Subaddr	X	I	X	I	-
Calling-Party-Number	X	I	X	I	-
Time-Date	X	I	X	I	-
MMS-Obj-Hdr	X	I	X	I	-
MMS-Ext-Hdr	X	I	X	I	-
Segmented-Info	X	I	X	I	-
Repeat-Indicator	X	I	X	I	-
<i>SECONDARY PART</i>					
MMS-Ext-Hdr	X	I	X	I	-
Repeat-Indicator	X	I	X	I	-
User Data	X	I	X	I	-

C.5.7 MMS-EXT-CMD-RPY command

For the purposes of this interworking annex all {MMS-EXT-CMD-RPY} messages, except Extended MMS Command type (octet 3a, <<MMS-GENERIC-HDR>> = Retrieve EE capabilities, are "Out of Scope" ("I").

The information elements of the {MMS-EXT-CMD-RPY} message with:

Ext. MMS Command type (octet 3a, <<MMS-GENERIC-HDR>> = Retrieve EE capabilities shall have the following status:

Table C.19: Status of MMS-EXT-CMD-RPY(Rtrv-Cap) command information elements

MMS IEs	Outgoing Command (PP > FP)		Incoming Command (FP > PP)		Ref.
	PP Tx	FP Rx	FP Tx	PP Rx	
<i>PRIMARY PART</i>					
MMS-Generic-Hdr	C1.1m	M	C2.2m	C2.2	C.7.2
Time-Date	X	I	X	I	-
MMS-Obj-Hdr	X	I	X	I	-
MMS-Ext-Hdr	C2.1m	M	C2.2m	C2.2	C.7.7
Segmented-Info	C2.1m	M	C2.2m	C2.2	ETS 300 175-5 [5], 7.7.37
Repeat-Indicator	C2.1m	M	C2.2m	C2.2	ETS 300 175-5 [5], 7.6.3
<i>SECONDARY PART</i>					
MMS-Ext-Hdr	X	I	X	I	-
Repeat-Indicator	X	I	X	I	-
User Data	X	I	X	I	-

C.5.8 MMS-STATUS command

Table C.20: Status of MMS-STATUS command information elements

MMS IEs	Outgoing Command (PP > FP)		Incoming Command (FP > PP)		Ref.
	PP Tx	FP Rx	FP Tx	PP Rx	
<i>PRIMARY PART</i>					
MMS-Generic-Hdr			C2.2m	C2.2	C.7.2
Called-Party-Number			X		-
Called-Party-Subaddr			X		-
Calling-Party-Number			X		-
Time-Date			X		-
MMS-Obj-Hdr			X		-
MMS-Ext-Hdr			X		-
Segmented-Info			X		-
Repeat-Indicator			X		-
<i>SECONDARY PART</i>					
MMS-Ext-Hdr			X		-
Repeat-Indicator			X		-
User Data			X		-

C.6 T.30 parameters to MMS IE mappings

C.6.1 DIS/DTC Capabilities mapping

The capabilities of a fax machine are defined and transferred in the T.30 DIS or DTC message. These are mapped to the MMS command information elements as shown in table C.21. These mappings are only implemented if Option O.1 is supported and required, otherwise default values apply.

Table C.21: DIS/DTC capabilities to M-MMS information element mapping

Bit No.	Description	MMS Messages	MMS IE	IE Field	Value
1-8	Not relevant to G3 fax	-	-	-	-
9	ITU-T Recommendation T.4 [15] Transmitter (polling)	{MMS-STATUS}	<<MMS-GNRC-HDR>>	Ext. Command Type	New message(s) available
10	ITU-T Recommendation T.4 [15] Receiver	{MMS-SEND-RPY}	<<MMS-GNRC-HDR>>	Command Outcome	Send request granted
11-14	Data Signalling Rate	{MMS-EXT-CMD-RPY} (Retrieve capabilities)	<<MMS-EXT-HDR>>	Modems Supported	see subclause C.7.7.3
15	Resolution capability	{MMS-EXT-CMD-RPY} (Retrieve capabilities)	<<MMS-EXT-HDR>>	Resolution	see subclause C.7.7.3
16	2 dimensional coding capability	{MMS-EXT-CMD-RPY} (Retrieve capabilities)	<<MMS-EXT-HDR>>	Image coding capabilities	see subclause C.7.7.3
17-18	Recording width capabilities	{MMS-EXT-CMD-RPY} (Retrieve capabilities)	<<MMS-EXT-HDR>>	Recording width capabilities	see subclause C.7.7.3
19-20	Maximum recording length capabilities	{MMS-EXT-CMD-RPY} (Retrieve capabilities)	<<MMS-EXT-HDR>>	Max. recording length capability	see subclause C.7.7.3
21-23	Min. scan line time capability at receiver	-	-	MMS IWU controls value	0 ms
24	Extend field	-	-	-	-
25	2400 bit/s handshaking	-	-	MMS IWU controls value	FP dependent (optional feature)
26	Uncompressed mode	{MMS-EXT-CMD-RPY} (Retrieve capabilities)	<<MMS-EXT-HDR>>	Image coding capabilities	see subclause C.7.7.3

(continued)

Table C.21 (continued): DIS/DTC capabilities to M-MMS information element mapping

Bit No.	Description	MMS Messages	MMS IE	IE Field	Value
27	Error correction mode	{MMS-EXT-CMD-RPY} (Retrieve capabilities)	<<MMS-EXT-HDR>>	ECM support	see subclause C.7.7.3
28	Set to "0"	-	-	MMS IWU controls value	"0"
29	Error limiting mode	-	-	MMS IWU controls value	FP dependent (optional feature)
30	Reserved for G4 capability on PSTN	-	-	MMS IWU controls value	FP dependent (optional feature)
31	ITU-T Recommendation T.6 [16] coding capability	{MMS-EXT-CMD-RPY} (Retrieve capabilities)	<<MMS-EXT-HDR>>	Image coding capabilities	see subclause C.7.7.3
32	Extend field	-	-	-	-
33	Validity of bits 17 & 18	{MMS-EXT-CMD-RPY} (Retrieve capabilities)	<<MMS-EXT-HDR>>	Recording width capabilities	see subclause C.7.7.3
34-39	Recording width capabilities	{MMS-EXT-CMD-RPY} (Retrieve capabilities)	<<MMS-EXT-HDR>>	Recording width capabilities	see subclause C.7.7.3
40	Extend field	-	-	-	-
41-45	Resolution capability	{MMS-EXT-CMD-RPY} (Retrieve capabilities)	<<MMS-EXT-HDR>>	Resolution	see subclause C.7.7.3
46	Min. scan line time capability at receiver	-	-	MMS IWU controls value	don't care
47	Selective polling capability	{MMS-EXT-CMD-RPY} (Retrieve capabilities)	<<MMS-EXT-HDR>>	Optional capabilities	see subclause C.7.7.3
48	Extend field	-	-	-	-
49	Subaddressing capability	{MMS-EXT-CMD-RPY} (Retrieve capabilities)	<<MMS-EXT-HDR>>	Optional capabilities	see subclause C.7.7.3
50	Password capability	{MMS-EXT-CMD-RPY} (Retrieve capabilities)	<<MMS-EXT-HDR>>	Optional capabilities	see subclause C.7.7.3
51	Capable to emit data file	{MMS-EXT-CMD-RPY} (Retrieve capabilities)	<<MMS-EXT-HDR>>	Optional capabilities	see subclause C.7.7.3
52	Reserved for fax service info (FSI)	{MMS-EXT-CMD-RPY} (Retrieve capabilities)	<<MMS-EXT-HDR>>	Optional capabilities	see subclause C.7.7.3
53	Binary file transfer	{MMS-EXT-CMD-RPY} (Retrieve capabilities)	<<MMS-EXT-HDR>>	Optional capabilities	see subclause C.7.7.3
54	Document transfer mode (DTM)	{MMS-EXT-CMD-RPY} (Retrieve capabilities)	<<MMS-EXT-HDR>>	Optional capabilities	see subclause C.7.7.3
55	Edifact transfer (EDI)	{MMS-EXT-CMD-RPY} (Retrieve capabilities)	<<MMS-EXT-HDR>>	Optional capabilities	see subclause C.7.7.3
56	Extend field	-	-	-	-
57	Basic transfer mode (BTM)	{MMS-EXT-CMD-RPY} (Retrieve capabilities)	<<MMS-EXT-HDR>>	Optional capabilities	see subclause C.7.7.3
58	Reserved for future negotiation for data	-	-	-	-
59	Capable to emit character file	{MMS-EXT-CMD-RPY} (Retrieve capabilities)	<<MMS-EXT-HDR>>	Optional capabilities	see subclause C.7.7.3
60	Character mode	{MMS-EXT-CMD-RPY} (Retrieve capabilities)	<<MMS-EXT-HDR>>	Optional capabilities	see subclause C.7.7.3
61	Reserved for control document	-	-	-	-
62	Mixed mode (ITU-T Recommendation T.4 [15], annex E)	-	-	-	-
63	Reserved for future neg. for char file trans.	-	-	-	-

(continued)

Table C.21 (concluded): DIS/DTC capabilities to M-MMS information element mapping

Bit No.	Description	MMS Messages	MMS IE	IE Field	Value
64	Extend field	-	-	-	-
65	Processable mode 26 (ITU-T Recommendation T.505 [21])	-	-	-	-
66	Digital network capability	-	-	-	-
67	Full & half duplex capability	-	-	-	-
68-71	Reserved for future	-	-	-	-
72	Extend field	-	-	-	-

C.6.2 DCS Capabilities mapping

The session parameters for a fax call are defined and transferred in the T.30 DCS message. These are mapped to the MMS command information elements as shown in table C.22. These mappings are only implemented if Option O.1 is supported and required, otherwise default values apply.

Table C.22: DCS fax session parameters to M-MMS information element mapping

Bit No.	Description	MMS Messages	MMS IE	IE Field	Value
1-8	Not relevant to G3 fax	-	-	-	-
9	ITU-T Recommendation T.4 [15] Transmitter (polling)	-	-	-	-
10	ITU-T Recommendation T.4 [15] Receiver	{MMS-SEND-RPY}	<<MMS-GNRC-HDR>>	Command Outcome	Send request granted
11-14	Data Signalling Rate	{MMS-SEND-REQ}/ {MMS-SEND-RPY}	<<MMS-EXT-HDR>>	Data Rate	see subclause C.7.7
15	Resolution	{MMS-SEND-REQ}/ {MMS-SEND-RPY}	<<MMS-EXT-HDR>>	Resolution	see subclause C.7.7
16	2 dimensional coding	{MMS-SEND-REQ}/ {MMS-SEND-RPY}	<<MMS-OBJ-HDR>>	Src. Data Type	ITU-T Recommendation T.4 [15], 1D or 2D
17-18	Recording width	{MMS-SEND-REQ}/ {MMS-SEND-RPY}	<<MMS-EXT-HDR>>	Recording width	see subclause C.7.7
19-20	Maximum recording length	{MMS-SEND-REQ}/ {MMS-SEND-RPY}	<<MMS-EXT-HDR>>	Max. recording length	see subclause C.7.7
21-23	Min. scan line time at receiver	-	-	MMS IWU controls value	0 ms
24	Extend field	-	-	-	-
25	2400 bit/s handshaking	-	-	MMS IWU controls value	FP dependent (optional feature)
26	Uncompressed mode	-	-	-	-
27	Error correction mode	{MMS-SEND-REQ}/ {MMS-SEND-RPY}	<<MMS-EXT-HDR>>	ECM support	see subclause C.7.7
28	Set to "0"	-	-	MMS IWU controls value	"0"
29	Error limiting mode	-	-	MMS IWU controls value	FP dependent (optional feature)
30	Reserved for G4 capability on PSTN	-	-	MMS IWU controls value	FP dependent (optional feature)

(continued)

Table C.22 (concluded): DCS fax session parameters to M-MMS information element mapping

Bit No.	Description	MMS Messages	MMS IE	IE Field	Value
31	ITU-T Recommendation T.6 [16] coding	{MMS-SEND-REQ}/ {MMS-SEND-RPY}	<<MMS-OBJ-HDR>>	Src. Data Type	see subclause C.7.7
32	Extend field	-	-	-	-
33	Validity of bits 17 & 18	{MMS-SEND-REQ}/ {MMS-SEND-RPY}	<<MMS-EXT-HDR>>	Recording width	see subclause C.7.7
34-39	Recording width	{MMS-SEND-REQ}/ {MMS-SEND-RPY}	<<MMS-EXT-HDR>>	Recording width	see subclause C.7.7
40	Extend field	-	-	-	-
41-45	Resolution	{MMS-SEND-REQ}/ {MMS-SEND-RPY}	<<MMS-EXT-HDR>>	Resolution	see subclause C.7.7
46	Don't care	-	-	-	-
47	Set to "0"	-	-	-	-
48	Extend field	-	-	-	-
49	Set to "0"	-	-	-	-
50	Set to "0"	-	-	-	-
51	Not used	-	-	-	-
52	Reserved for fax service info (FSI)	{MMS-SEND-REQ}/ {MMS-SEND-RPY}	<<MMS-GNRC-HDR>> <<MMS-OBJ-HDR>>	Service Subtype Src. Data Type	FSI FSI
53	Binary file transfer	{MMS-SEND-REQ}/ {MMS-SEND-RPY}	<<MMS-GNRC-HDR>> <<MMS-OBJ-HDR>>	Service Subtype Src. Data Type	BFT ITU-T Recommendation T.434 [20]
54	Document transfer mode (DTM)	{MMS-SEND-REQ}/ {MMS-SEND-RPY}	<<MMS-GNRC-HDR>> <<MMS-OBJ-HDR>>	Service Subtype Src. Data Type	DTM ITU-T Recommendation T.434 [20]
55	Edifact transfer (EDI)	{MMS-SEND-REQ}/ {MMS-SEND-RPY}	<<MMS-GNRC-HDR>> <<MMS-OBJ-HDR>>	Service Subtype Src. Data Type	EDI ITU-T Recommendation T.434 [20]
56	Extend field	-	-	-	-
57	Basic transfer mode (BTM)	{MMS-SEND-REQ}/ {MMS-SEND-RPY}	<<MMS-GNRC-HDR>> <<MMS-OBJ-HDR>>	Service Subtype Src. Data Type	BTM ITU-T Recommendation T.434 [20]
58	Reserved for future negotiation for data	-	-	-	-
59	Not used	-	-	-	-
60	Character mode	{MMS-SEND-REQ}/ {MMS-SEND-RPY}	<<MMS-GNRC-HDR>> <<MMS-OBJ-HDR>>	Service Subtype Src. Data Type	Char. mode Char/Text type
61	Reserved for control document	-	-	-	-
62	Mixed mode (ITU-T Recommendation T.4 [15], annex E)	-	-	-	-
63	Reserved for future neg. for char file trans.	-	-	-	-
64	Extend field	-	-	-	-
65	Processable mode 26 (ITU-T Recommendation T.505 [21])	-	-	-	-
66	Digital network capability	-	-	-	-
67	Full & half duplex capability	-	-	-	-
68-71	Reserved for future	-	-	-	-
72	Extend field	-	-	-	-

C.7 Service specific Information Element codings

C.7.1 <<IWU-ATTRIBUTES>>

Within the context of this interworking annex this information elements is used within the {CC-SETUP} message to select and configure the RT G3 fax MMS IWU.

Only codings which are relevant to this annex are shown here.

Bits

8	7	6	5	4	3	2	1	Octet:
0	<<IWU-ATTRIBUTES>>							1
Length of Contents (L)								2
1	Coding		Profile					3
1	Neg. Indicator			Spare				4
1	ECM	Rsrv	Data Rates					5

With the context of this interworking annex the following codings shall always be used for this information element:

Coding standard (octet 3):

Bits	7	6	Meaning
0	1		Profile defined coding
All other values reserved.			

Profile (octet 3):

Bits	5	4	3	2	1	Meaning
0	0	1	0	0		F data profile

Negotiation indicator (octet 4):

Bits	7	6	5	Meaning
0	0	0		Negotiation not possible
1	0	0		Exchanged parameter negotiation

Data Rates (octet 4, bits 1-5):

These codings define which of the modems and associated data signalling rates defined by T.30 DIS/DTC bits 11-14 the IWU may use, provided they are supported by the IWU itself.

Bits	5	4	3	2	1	Meaning
x	x	x	x	1		Highest available speed
x	x	x	1	0		DIS/DTC bit 11
x	x	1	x	0		DIS/DTC bit 12
x	1	x	x	0		DIS/DTC bit 13
1	x	x	x	0		DIS/DTC bit 14

ECM support (octet 4, bit 7):

In the FP to PP direction this coding defines whether the optional Error Correction Mode (ECM) defined by T.30 DIS/DTC bit 27 is supported by both EE and IWU. In the PP to FP direction this coding defines whether the IWU should use the optional Error Correction Mode (ECM) defined by T.30 DIS/DTC bit 27 if it is supported by both IWU and EE.

Bits	7	FP-PP Meaning	PP-FP Meaning
	0	Not supported	Do not indicate ECM support
	1	Supported	Indicate ECM support if available [default]

C.7.2 <<MMS-GENERIC-HDR>>

When the Service type field (octet 5) of this information element = Facsimile group 3 (real-time) the Service Subtype field (octet 5a) may also be included, and if included shall be interpreted as follows:

Service Sub-type (octet 5a) (Optional):

This octet is optional. If omitted the receiving entity shall assume a coding of 0 0 0 0 0 0 0.

Bits	7 6 5 4 3 2 1	Meaning
	0 0 0 0 0 0 0	STD: Basic Telefax G3 Service (ITU-T Recommendation T.4 [15]) [default] Codings applicable only if Service type (octet 5) = Facsimile group 3 (real-time): (support for the following Service Sub-types is optional)
	0 0 0 0 0 0 1	BFT: Telematic File Transfer (TFT) of Telefax G3: Binary File Transfer
	0 0 0 0 0 1 0	DTM: Telematic File Transfer (TFT) of Telefax G3: Document Transparent Mode
	0 0 0 0 0 1 1	EDI: Telematic File Transfer (TFT) of Telefax G3 Service: Edifact [optional]
	0 0 0 0 1 0 0	BTM: Telematic File Transfer (TFT) of Telefax G3: Basic Transparent Mode
	0 0 0 0 1 0 1	Character Mode
	1 0 0 0 0 0 0	Reserved for facsimile service info (FSI)

C.7.3 <<CALLED-PARTY-NUMBER>>

The <<CALLED-PARTY-NUMBER>> IE is coded as specified in subclause 7.7.7 of ETS 300 175-5 [5] and in subclause F.3.4 of this ETS.

The called party PSTN/ISDN number may be optionally transferred in the <<CALLED-PARTY-NUMBER>> IE of a multipart level 1 MMS-SEND-REQ message.

The T.30 Called Subscriber Identification (CSI) is returned from the called fax machine (EE/PP) in the <<MMS-EXT-HDR>> IE response to a MMS-EXT-CMD(Retrieve EE capabilities) message, see subclause C.7.7.4, and optionally in the <<CALLED-PARTY-NUMBER>> IE of a Multipart Level 2 MMS-SEND-RPY message.

C.7.4 <<CALLED-PARTY-SUBADDR>>

The <<CALLED-PARTY-SUBADDR>> IE is coded as specified in subclause 7.7.8 of ETS 300 175-5 [5] and in subclause F.3.5 of this ETS.

The T.30 Subaddress (SUB) may be optionally transferred in the <<CALLED-PARTY-SUBADDR>> IE of a Multipart Level 1 MMS-SEND-REQ message.

The T.30 Selective Polling (SEP) may be optionally transferred in the <<CALLED-PARTY-SUBADDR>> IE of a Multipart Level 2 MMS-SEND-REQ message.

C.7.5 <<CALLING-PARTY-NUMBER>>

The <<CALLING-PARTY-NUMBER>> IE is coded as specified in subclause 7.7.9 of ETS 300 175-5 [5] and in subclause F.3.4 of this ETS. If necessary this IE may be repeated in the same message using the <<REPEAT-INDICATOR>> IE.

The calling party PSTN/ISDN Number may be optionally transferred in the <<CALLING-PARTY-NUMBER>> IE of a multipart level 1 MMS-SEND-REQ message.

The T.30 Calling Subscriber Identification (CIG) may be optionally transferred in the <<CALLING-PARTY-NUMBER>> IE of a multipart level 1 MMS-SEND-REQ message.

The T.30 Password (PWD) may be optionally transferred in the <<CALLING-PARTY-NUMBER>> IE of a Multipart Level 1 MMS-SEND-REQ message only if the T.30 Calling Subscriber Identification (CIG) is transferred prior to it in the same message

The T.30 Transmitting Subscriber Identification (TSI) may be optionally transferred in the <<CALLING-PARTY-NUMBER>> IE of a Multipart Level 2 MMS-SEND-REQ message.

C.7.6 <<MMS-OBJ-HDR>>

The codings for the <<MMS-OBJ-HDR>> information element are specified in subclause B.1.2. All the codings listed in this subclause shall be valid codings for the purposes of this interworking annex unless they are explicitly listed below. Of the codings listed below only the codings listed are valid codings for the purposes of this interworking annex.

Source user data category (Src UD Cat.) (octet 4):

Only the following codings shall be used for this interworking annex:

- Image user data
- Other user data

Source user data transfer encoding (octet 4):

Only the following codings shall be used for this interworking annex:

- No transfer encoding

Destination user data category (Dest UD Cat.) (octet 4a):

This octet shall not be included.

Destination user data transfer encoding (octet 4a):

This octet shall not be included.

Source user data type (octet 5):

Only the following codings shall be used for this interworking annex:

Single field user data types (octet 5a shall not be included):

- Basic text
- ITU-T Recommendation T.4 [15] one dimensional coded image
- ITU-T Recommendation T.4 [15] two dimensional coded image
- ITU-T Recommendation T.6 [16] coded image
- Telematic File Transfer (TFT), ITU-T Recommendation T.434 [20]

Destination user data type (octet 5b):

This octet shall not be included.

Extended destination user data type (octet 5c):

This octet shall not be included.

C.7.7 <<MMS-EXT-HDR>>

Within the context of this interworking annex the <<MMS-EXT-HDR>> information element may be optionally included in some M-MMS messages as specified in clauses C.4 and C.5.

It is used to convey information about fax capabilities (DIS/DTC) and fax session parameters (DCS) which can not be conveyed in the <<MMS-GENERIC-HDR>> or <<MMS-OBJ-HDR>> information elements. This information shall only be conveyed if Option O.1 is supported. Default values are shown in the codings below which shall be used if the Information Element (IE) or octet/coding is omitted.

Only codings which are permitted within the context of this interworking annex are shown here.

Bits								
8	7	6	5	4	3	2	1	Octet:
0 <<MMS-EXT-HDR>>								1
Length of Contents (L)								2
0/1		Attribute Cat.		Attribute Identifier				3
1 Extended Attribute Identifier								3a
Message Attribute(s) (octet 1)								4
Message Attribute(s) (octet 2)								5
....								...
Message Attribute(s) (octet L-1 or L-2)								L+2

With the context of this interworking annex the following codings shall always be used for this information element:

Attribute Category (octet 3):

Bits	7 6 5	Meaning
	0 0 0	Extended MMS Object header
	0 1 0	MMS IWU configuration parameters
	0 1 1	Capability parameters

Attribute identifier (octet 3):

All the Attribute identifier codings shall be interpreted uniquely for each Attribute category (octet 3, bits 5-7) coding.

Bits	4 3 2 1	Meaning
------	---------	---------

Codings applicable only if Attribute category (octet 3, bits 7-5) = Extended MMS Object header:

0 0 0 0	G.3 Fax object parameters.
0 1 0 0	G.3 Fax Called Subscriber Identity (CSI)

Codings applicable only if Attribute category (octet 3, bits 7-5) = MMS IWU parameters:

0 0 0 0	G.3 Fax transmission parameters.
---------	----------------------------------

Codings applicable only if Attribute category (octet 3, bits 7-5) = Capability parameters:

0 0 0 0	G.3 Fax capability parameters.
---------	--------------------------------

Extended attribute identifier (octet 3a):

For the purposes of this interworking annex this octet shall not be included.

C.7.7.1 G3 Fax object parameters

The following codings of the <<MMS-EXT-HDR>> IE shall be used to convey and interwork the T.30 DCS fax session parameters shown below. These parameters are normally transferred in a Level 2 or 3 MMS-SEND-REQ/RPY message as specified in clauses C.8 and C.9. If none of the parameters contained in this coding of the IE have changed since their most recent transmission during this call then this <<MMS-EXT-HDR>> IE with these codings may be optionally omitted from the specified messages.

Additional T.30 DCS fax session parameters may be transferred in another <<MMS-EXT-HDR>> IE in the same message and coded as per subclause C.7.7.2, using the <<REPEAT-INDICATOR>> IE if necessary.

Message attribute(s) (octets 4 to L+2):

The following message attributes codings are to be used when the Attribute Category = Extended MMS object header and the Attribute Identifier = G.3 Fax object parameters

Bits								Octet:
8	7	6	5	4	3	2	1	
0	<<MMS-EXT-HDR>>							1
Length of Contents (L)								2
1	Attribute Cat.			Attribute Identifier				3
1	Resolution							4
1	Recording width							5
1	Max. Rec. L			Resrv.		Rec. W.		6

Resolution (octet 4):

This coding defines the proposed fax session parameter for the resolution as defined by T.30 DCS bits 15 and 41-45 are supported by the PP/EE.

NOTE: Not all the resolutions listed below are valid with all of the possible image codings (ITU-T Recommendation T.4 [15] 1D, 2D and ITU-T Recommendation T.6 [16]). It is up to the initiating entity to ensure that the coding is valid for the image coding defined in the <<MMS-OBJ-HDR>> IE.

Bits	7 6 5 4 3 2 1	Meaning
	x x x x x 1	DCS bit 15
	x x x x x 1 x	DCS bit 41
	x x x x 1 x x	DCS bit 42
	x x x 1 x x x	DCS bit 43
	x x 1 x x x x	DCS bit 44
	x 1 x x x x x	DCS bit 45
	1 x x x x x x	Reserved

Recording width (octet 5):

This coding defines the proposed fax session parameter for the recording width as defined by T.30 DCS bits 17-18, 33, 34-37 are supported by the PP/EE.

Bits	7 6 5 4 3 2 1	Meaning
	x x x x x 1	DCS bit 17
	x x x x x 1 x	DCS bit 18
	x x x x 1 x x	DCS bit 33
	x x x 1 x x x	DCS bit 34
	x x 1 x x x x	DCS bit 35
	x 1 x x x x x	DCS bit 36
	1 x x x x x x	DCS bit 37

Recording width (octet 6, bits 1-2):

This coding defines the proposed fax session parameter for the recording width as defined by T.30 DCS bits 38-39 are supported by the PP/EE.

Bits	2 1	Meaning
	x 1	DCS bit 38
	1 x	DCS bit 39

Max. Recording length (octet 6, bits 5-7):

This coding defines the proposed fax session parameter for the maximum recording length as defined by T.30 DCS bits 19-20 are supported by the PP/EE.

Bits	7 6 5	Meaning
	x x 1	A4 (297 mm)
	x 1 x	B4 (364 mm)
	1 x x	Unlimited

C.7.7.2 G3 Fax transmission parameters

The following codings of the <<MMS-EXT-HDR>> IE shall be used to convey and interwork the T.30 DCS fax session parameters shown below. These parameters are normally transferred in a Level 2 or 3 MMS-SEND-REQ/RPY message as specified in clauses C.8 and C.9. If none of the parameters contained in this coding of the IE have changed since their most recent transmission during this call then this <<MMS-EXT-HDR>> IE with these codings may be optionally omitted from the specified messages.

Additional T.30 DCS fax session parameters may be transferred in another <<MMS-EXT-HDR>> IE in the same message and coded as per subclause C.7.7.1, using the <<REPEAT-INDICATOR>> IE if necessary.

The following message attributes codings are to be used when the Attribute Category = MCE IWU configuration parameters and the Attribute Identifier = G.3 Fax transmission parameters

Bits								
8	7	6	5	4	3	2	1	Octet:
0	<<MMS-EXT-HDR>>							1
Length of Contents (L)								2
1	Attribute Cat.			Attribute Identifier				3
1	ECM	Rsrv	Data Rate					4

Data Rate (octet 4, bits 1-5):

This coding defines the proposed fax session parameter for the data signalling rate and associated modem as defined by T.30 DCS bits 11-14 are supported by the PP/EE.

Bits	5 4 3 2 1	Meaning
	x x x x 1	Highest available speed
	x x x 1 0	DTC bit 11
	x x 1 x 0	DTC bit 12
	x 1 x x 0	DTC bit 13
	1 x x x 0	DTC bit 14

ECM support (octet 4, bit 7):

This coding defines the proposed fax session parameter for the Error Correction Mode (ECM) as defined by T.30 DCS bit 27 are supported by the PP/EE.

Bits	7	FP-PP Meaning	PP-FP Meaning
	0	No ECM	Do not use ECM
	1	ECM	Use ECM, if possible [default]

C.7.7.3 G3 Fax capabilities parameters

The following codings of the <<MMS-EXT-HDR>> IE shall be used to convey and interwork the T.30 DIS/DTC fax capabilities parameters shown below. These parameters are normally transferred in the response to a MMS-EXT-CMD(Retrieve EE capabilities) message as specified in clauses C.8 and C.9. If none of the parameters contained in this coding of the IE have changed since their most recent transmission during this call then this <<MMS-EXT-HDR>> IE with these codings may be optionally omitted from the specified messages.

The T.30 Called Subscriber Identity (CSI) parameter may additionally be transferred in another <<MMS-EXT-HDR>> IE in the same message and coded as per subclause C.7.7.4, using the <<REPEAT-INDICATOR>> IE if necessary.

The following message attributes codings are to be used when the Attribute Category = Capability parameters and the Attribute Identifier = G.3 Fax Capability parameters

Bits								Octet:
8	7	6	5	4	3	2	1	
0 <<MMS-EXT-HDR>>								1
Length of Contents (L)								2
1		Attribute Cat.			Attribute Identifier			3
1		ECM	Rsrv	Modems				4
0/1		Reserved			Image Coding			5
1		Resolution						6
1		Recording width						7
1		Max. Rec. L		Resrv.	Rec. W.		8	
0/1		Optional capabilities						9
0/1		Optional capabilities						9a
0/1		Optional capabilities (Resrv.)						9b
1		Optional capabilities (Resrv.)						9c

Modems supported (octet 4, bits 1-5):

In the FP to PP direction these codings define which of the modems and associated data signalling rates defined by T.30 DIS/DTC bits 11-14 are supported by both EE and IWU. In the PP to FP direction these codings define which of these modems and associated data signalling rates the IWU may indicate as being supported, provided they are supported by the IWU itself.

Bits	5 4 3 2 1	Meaning
	x x x x 1	Highest available speed
	x x x 1 0	DIS/DTC bit 11
	x x 1 x 0	DIS/DTC bit 12
	x 1 x x 0	DIS/DTC bit 13
	1 x x x 0	DIS/DTC bit 14

ECM support (octet 4, bit 7):

In the FP to PP direction this coding defines whether the optional Error Correction Mode (ECM) defined by T.30 DIS/DTC bit 27 is supported by both EE and IWU. In the PP to FP direction this coding defines whether the IWU should use the optional Error Correction Mode (ECM) defined by T.30 DIS/DTC bit 27 if it is supported by both IWU and EE.

Bits	7	FP-PP Meaning	PP-FP Meaning
	0	Not supported	Do not indicate ECM support
	1	Supported	Indicate ECM support if available [default]

Image coding capability (octet 5):

These codings define which of the image codings defined by T.30 DIS/DTC bits 16, 26 and 31 are supported by the PP/EE.

Bits	3 2 1	Meaning
	x x 1	ITU-T Recommendation T.4 [15], 1 dimensional
	x 1 x	ITU-T Recommendation T.4 [15], 2 dimensional
	1 x x	ITU-T Recommendation T.6 [16]

Resolution capability (octet 6):

These codings define which of the resolutions defined by T.30 DIS/DTC bits 15 and 41-45 are supported by the PP/EE.

NOTE: Not all the resolutions listed below are valid with all of the possible image codings (ITU-T Recommendation T.4 [15] 1D, 2D and ITU-T Recommendation T.6 [16]). It is up to the initiating entity to ensure that the coding is valid for the image coding defined in the <<MMS-OBJ-HDR>> IE.

Bits	7 6 5 4 3 2 1	Meaning
	x x x x x 1	DIS/DTC bit 15
	x x x x x 1 x	DIS/DTC bit 41
	x x x x 1 x x	DIS/DTC bit 42
	x x x 1 x x x	DIS/DTC bit 43
	x x 1 x x x x	DIS/DTC bit 44
	x 1 x x x x x	DIS/DTC bit 45
	1 x x x x x x	Reserved

Recording width capability (octet 7):

These codings define which of the recording widths defined by T.30 DIS/DTC bits 17-18, 33 and 34-39 are supported by the PP/EE.

Bits	7 6 5 4 3 2 1	Meaning
	x x x x x 1	DIS/DTC bit 17
	x x x x x 1 x	DIS/DTC bit 18
	x x x x 1 x x	DIS/DTC bit 33
	x x x 1 x x x	DIS/DTC bit 34
	x x 1 x x x x	DIS/DTC bit 35
	x 1 x x x x x	DIS/DTC bit 36
	1 x x x x x x	DIS/DTC bit 37

Recording width capability (octet 8, bits 1-2):

These codings define which of the recording widths defined by T.30 DIS/DTC bits 17-18, 33 and 34-39 are supported by the PP/EE.

Bits	2 1	Meaning
	x 1	DCS bit 38
	1 x	DCS bit 39

Max. recording length capability (octet 8, bits 5-7):

These codings define which of the maximum recording lengths defined by T.30 DIS/DTC bits 19-20 are supported by the PP/EE.

Bits	7 6 5	Meaning
	x x 1	A4 (297 mm)
	x 1 x	B4 (364 mm)
	1 x x	Unlimited

Optional capabilities (octet 9):

Inclusion of this octet is optional. This octet defines which of the optional capabilities defined by T.30 DIS/DTC bits 47 and 49-54 are supported by the PP or EE/IWU.

Bits	7 6 5 4 3 2 1	Meaning
	x x x x x 1	DIS/DTC bit 47
	x x x x x 1 x	DIS/DTC bit 49
	x x x x 1 x x	DIS/DTC bit 50
	x x x 1 x x x	DIS/DTC bit 51
	x x 1 x x x x	DIS/DTC bit 52
	x 1 x x x x x	DIS/DTC bit 53
	1 x x x x x x	DIS/DTC bit 54

Optional capabilities (octet 9a):

Inclusion of this octet is optional. This octet defines which of the optional capabilities defined by T.30 DIS/DTC bits 55 and 57-60 are supported by the PP or EE/IWU.

Bits	7 6 5 4 3 2 1	Meaning
	x x x x x 1	DIS/DTC bit 55
	x x x x x 1 x	DIS/DTC bit 57
	x x x x 1 x x	DIS/DTC bit 58
	x x x 1 x x x	DIS/DTC bit 59
	x x 1 x x x x	DIS/DTC bit 60
	x 1 x x x x x	Reserved
	1 x x x x x x	Reserved

Optional capabilities (octet 9b):

Inclusion of this octet is optional. This octet is reserved to define which of the as yet unspecified optional T.30 capabilities are supported by the PP or EE/IWU.

Optional capabilities (octet 9c):

Inclusion of this octet is optional. This octet is reserved to define which of the as yet unspecified optional T.30 capabilities are supported by the PP or EE/IWU.

C.7.7.4 G3 Fax Called Subscriber Identity (CSI)

The following codings of the <<MMS-EXT-HDR>> IE shall be used to convey and interwork the T.30 Called Subscriber Identity (CSI) parameter shown below. These parameters are normally transferred in the response to a MMS-EXT-CMD(Retrieve EE capabilities) message as specified in clauses C.8 and C.9. If this parameter has not changed since its most recent transmission during this call then this <<MMS-EXT-HDR>> IE with this coding may be optionally omitted from the specified messages.

The T.30 DIS/DTC fax capabilities parameters may additionally be transferred in another <<MMS-EXT-HDR>> IE in the same message and coded as per subclause C.7.7.3, using the <<REPEAT-INDICATOR>> IE if necessary.

The following message attributes codings are to be used when the Attribute Category = Extended MMS object header and the Attribute Identifier = G.3 Fax Called Subscriber Identity (CSI)

Bits								
8	7	6	5	4	3	2	1	Octet:
0 <<MMS-EXT-HDR>>								1
Length of Contents (L)								2
1		Attribute Cat.			Attribute Identifier			3
0/1		CSI character 1						4
0/1		CSI character 2						4a
0/1		CSI character 3						4b
....								...
1		CSI character n						L+2

As specified in ITU-T Recommendation T.30 [14], subclause 5.3.6.1.1, 2, the Called Subscriber Identification (CSI) may consist of up to 20 numeric digits coded as defined in table 3 of ITU-T Recommendation T.30 [14]. The above CSI characters shall be coded in accordance with this table, except that the Fill bit (MSB, bit 8) shall be replaced with the DECT "Ext" bit as show above.

Using this "Ext" bit it is permitted to transmit less than 20 CSI characters, where the last (20-n) characters shall be interpreted as "Space".

C.7.8 <<USER-DATA>>

The <<USER-DATA>> is transmitted in segments of 256 octets (with the possible exception of the last segment). This maximum segment size corresponds directly with one of the two "block sizes" which may be used during T.30 ECM transmissions and re-transmissions.

These segments are transmitted in the U-plane using LAPU as specified in subclause B.2.1. The segmentation mechanism is fully catered for and built into LAPU, allowing easy segmentation and re-assembly of the required segments.

The <<USER-DATA>> information content shall be coded into the 256 octet segments as specified for the 256 octet ITU-T Recommendation T.4 [15] Error Correction Mode facsimile data field as specified in subclause A.3.6.2 of ITU-T Recommendation T.4 [15].

NOTE: The <<USER-DATA>> segments shall not include any HDLC bit stuffing to preclude non-valid HDLC flag sequences.

C.8 Interworking procedures - outgoing fax service

The interworking procedures in this annex are based on the reference configuration shown in figure C.1. It may be noted that this figure gives the example of a windows based ITU-T Recommendation T.611 [22] fax application in the PP. However the fax application could just as easily be a standard scanning and printing based fax machine or even an IWF which connects the MMSP to a standard Class 1/2 fax modem for use in RLL type applications. It may also be noted such an IWU (fax modem + IWF), like the FP IWU, may be very easily implemented using a standard Class 1/2 fax modem because of the similarity between Class fax commands and the MMS commands.

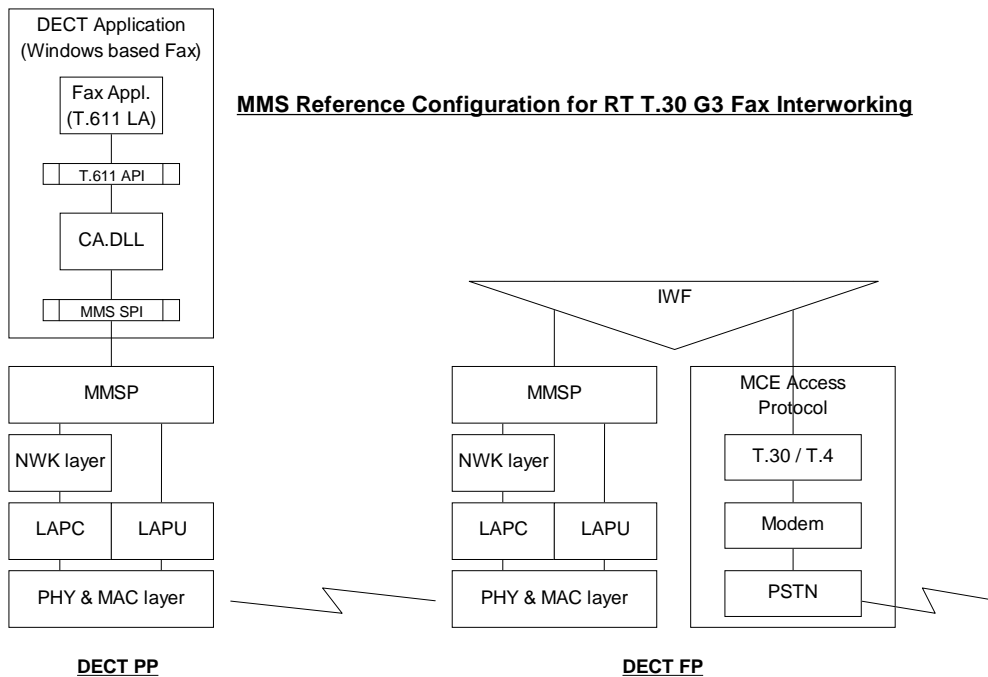

Figure C.1: DECT MMS to real-time T.30 G3 fax interworking

The typical message sequence diagrams showing progressions through and within all the phases of a fax call (phase A through to phase E) are shown in figures C.3 to C.11. These diagrams are informative only for the purposes of illustrating how the procedures specified in this subclause can operate.

C.8.1 General procedures

C.8.1.1 Structure of a MMS fax message - multipart message procedures

These interworking procedures shall make use of the multipart message procedures defined in subclause A.1.3.10. and use them to structure a MMS fax message as a multipart message of 3 levels. This type of structure is directly compatible with the structure of T.30 fax messages since ITU-T Recommendation T.30 [14] allows multiple, different type, fax messages (Level 2) to be sent during a single fax call (Level 1) and each fax message may consist of one or more pages (or TFT files) (Level 3) with the same parameters (i.e. the same DCS session parameters).

Multipart message Level 1: This level shall be initiated at the start of the M-MMS phase of a fax call (during T.30 phase A) by sending a {MMS-SEND-REQ} or {MMS-RETRIEVE} message which shall be identified in the <<MMS-OBJ-HDR>> by the "Src. Data type" = "Multipart message parent - multiple messages" and which shall not include a "Multipart parent message identifier". The "MMS message identifier" in the <<MMS-GENERIC-HDR>> of this message shall be used as the "Multipart parent message identifier" for the subsequent Level 2 message parts.

The top level multipart message shall be used to initiate and terminate the transfer of a set of multiple fax messages in one direction. It shall always be initiated by the sending entity. In ITU-T Recommendation T.30 [14] the sending entity is always initially defined to be the entity which initiated the fax call. If the sending entity (which also controls the T.30 link) wishes to RETRIEVE a fax (fax polling, Options O.2 and O.3) then it shall terminate the current MMS-SEND Level 1 message and initiate a new MMS-RETRIEVE Level 1 message.

Termination of a multipart message shall be implemented by sending a {MMS-SEND-REQ} message which is identified in the <<MMS-OBJ-HDR>> by the "Src. Data type" = "Multipart message end" and which includes a "Multipart parent message identifier" = the "MMS message identifier" of the multipart parent which initiated the multipart message.

Multipart message Level 2: This level shall be initiated during T.30 phase B by sending a {MMS-SEND-REQ} message which is identified in the <<MMS-OBJ-HDR>> by the "Src. Data type" = "Multipart message parent - multiple messages" and which shall include a "Multipart parent message identifier" which references the "MMS message identifier" of the Level 1 multipart parent. The "MMS message identifier" in the <<MMS-GENERIC-HDR>> of this message shall be used as the "Multipart parent message identifier" for the subsequent Level 3 message parts.

The 2nd level message shall be used to define the fax session parameters for the transfer of the subsequent fax message, i.e. until the next T.30 EOM is transmitted. The {MMS-SEND-REQ} message which initiates this level may optionally contain the <<MMS-EXT-HDR>> IE(s) in which it may explicitly communicate the DCS fax session parameters.

Explicit termination of a Level 2 multipart message shall be implemented by sending a {MMS-SEND-REQ} message which is identified in the <<MMS-OBJ-HDR>> by the "Src. Data type" = "Multipart message end" and which includes a "Multipart parent message identifier" = the "MMS message identifier" of the multipart parent which initiated the multipart message. It may also be implemented implicitly by the termination of its multipart parent.

Multipart message Level 3: Unlike the other 2 levels, Level 3 messages are not in them selves multipart messages. They are the actual message parts which make up the Level 2 (and ultimately the Level 1) multipart messages. Level 3 messages shall be initiated during T.30 phase C or D by sending a {MMS-SEND-REQ} or a {MMS-SEND} message which is identified in the <<MMS-OBJ-HDR>> by the "Src. Data type" = fax message data type (e.g. "T.4 one dimensional coded image") and which shall include a "Multipart parent message identifier" which references the "MMS message identifier" of the Level 2 multipart parent. This is the lowest level (deepest nesting) of multipart message. Therefore the "MMS message identifier" in the <<MMS-GENERIC-HDR>> of this message shall not be referenced by any other MMS messages.

The 3rd level message shall be used either to request the transfer or to enable the actual transfer of a fax page, which is either a single ITU-T Recommendation T.4 [15] coded fax page or a Telematic File Transfer (TFT) file. A Level 3 {MMS-SEND-REQ} is used for each subsequent fax page of the same type and with the same session parameters (DCS) as the previous fax page. If the EE or IWU requests a retraining sequence (see figure C.5 and C.15) then this may cause the session parameters to be re-negotiated, these may then be communicated to the PP in the {MMS-SEND-RPY}/ {MMS-SEND-REQ} message. However this message part (fax page) shall be part of the same Level 2 multipart message as the previous fax page.

For the purposes of this interworking annex the level 3 {MMS-SEND} message shall not request a reply from either the MCE or the EE.

C.8.1.2 Assignment of MMS message identifiers

The procedures for the assignment of the MMS message identifiers in the <<MMS-GENERIC-HDR>> IE shall follow the procedures set out in subclause A.1.3.9 of this ETS. There are no specific requirements on the assignment of the "Action ID", except that as stated in subclause A.1.3.9 that it shall be locally unique at the originating entity (i.e. that entity which assigned the value) for the duration during which the MMS command and responses are active. This has particular implications for MMS commands which define MMS objects of Src./Dest. Data type (in <<MMS-OBJ-HDR>>) = "Multipart message parent...", see subclause C.8.1.3.

All the MMS commands in this interworking annex use at most a single reply in response to a single MMS command. Therefore any "Action ID" which has not been used to define a multipart message (Src./Dest. Data type (in <<MMS-OBJ-HDR>>) <> "Multipart message parent...") may be freely re-used as soon as the corresponding {MMS-xxxx-RPY} message is received.

C.8.1.3 Assignment of Multipart parent message identifiers

"Action ID" values which are used to define a multipart message (Src./Dest. Data type (in <<MMS-OBJ-HDR>>) = "Multipart message parent...") may be freely assigned in the same manner as other MMS messages. However such "Action ID"s shall not be re-used until the multipart message has been either explicitly or implicitly terminated.

Explicit termination of a multipart message shall be implemented by sending a {MMS-SEND-REQ} message which is identified in the <<MMS-OBJ-HDR>> by the "Src. Data type" = "Multipart message end" and which includes a "Multipart parent message identifier" = the "MMS message identifier" of the multipart parent which initiated the multipart message. If the multipart parent of a message is itself a multipart message then it may also be implicitly terminated by the termination of its multipart parent.

C.8.1.4 Management of MMS message and IE options

MMS message and IE options shall be managed in accordance with the procedures set out in subclauses A.1.3.11.1 (mandatory) and A.1.3.11.2 (optional). No further procedures are necessary for the management of the options specified within this interworking annex.

C.8.1.5 Procedure for support of Option O.4 - T.30 Error Correction Mode (ECM)

Support of the ITU-T Recommendation T.30 [14] Error Correction Mode (ECM), Option O.4, does not require any additional functionality in the DECT PP or any additional support for MMS protocol elements or procedures (since the MMS transport mechanism is fully error corrected) but requires only that the MMS IWU in the FP supports this ITU-T Recommendation T.30 [14] optional feature.

As specified in subclause C.7.8 of this interworking annex the <<USER-DATA>> is transmitted in segments of 256 octets (with the possible exception of the last segment). This maximum segment size corresponds directly with one of the two "block sizes" which may be used during T.30 ECM transmissions and re-transmissions. The other "block size" is 64 octets. When operating in the ECM mode the FP shall forward each correctly received segment from the PP to the EE as either a single block of 256 octets or 4 separate blocks of 64 octets as specified in annex A of ITU-T Recommendation T.30 [14]. It shall also store each segment/block until that block has been acknowledged by the EE as having been received correctly.

The interworking procedures specified in subclauses C.8.2 to C.8.7 relate specifically to the interworking of the non-ECM T.30 mode of operation. For interworking to the T.30 ECM procedures the same MMS message sequences shall be used and the non-ECM T.30 procedures shall be replaced with their equivalent ECM T.30 procedures as specified in annex A of ITU-T Recommendation T.30 [14].

If the FP IWU and the EE both support ECM then by default it shall be used for all outgoing faxes. If Option O.1 is supported, the PP may instruct the FP not to use ECM for outgoing faxes in the <<MMS-EXT-HDR>> IE of the Level 2 multipart MMS-SEND-REQ message, see subclause C.7.7. For incoming faxes the FP IWU shall by default indicate its support for ECM, if indeed it does support it. As per the ITU-T Recommendation T.30 [14] procedures the EE shall then decide whether it should be used or not. If Option O.1 is supported, the PP may instruct the FP during the Retrieval of PP capabilities procedure to not indicate its support for ECM to the EE, see subclause C.7.7.

Error Correction Mode (ECM) support (in the FP) is required to support any of the services defined in clause C.2 other than the Basic Telefax G3 Service (STD). This is a basic requirement of the ITU-T Recommendation T.30 [14] protocol.

C.8.2 Call setup procedures (T.30 phase A)

The procedures in this phase are accomplished through a combination of C-MMS and M-MMS primitives and messages.

C.8.2.1 PP side procedures

These procedures are the equivalent of the procedures for automatic operation at the calling fax station as specified in subclauses 3.1.3 and 3.1.4 of ITU-T Recommendation T.30 [14] (Operating methods 3 & 4). Facilities for manual operation at the calling fax station (i.e. at the PP or IWU) as specified in subclauses 3.1.1 and 3.1.2 of ITU-T Recommendation T.30 [14] (Operating methods 1 & 2) are for further study.

The PP shall initiate an outgoing MMS call to the FP using the procedures specified in clause 9 of this ETS by reference to the C.2 Data Service Profile (ETS 300 651 [13]). These procedures specify the use of either GAP-like call control procedures or Packet Mode procedures depending on whether call progress information and/or digit by digit dialling are required.

Regardless of which procedures are used the <<IWU-ATTRIBUTES>> information element shall be included with the Coding Standard (octet 3, bits 6-7) = "Profile defined coding" and the Profile (octet 3 bits 1-5) = "F data profile". The remainder of the <<IWU-ATTRIBUTES>> octets shall be coded as specified in subclause C.7.1.

Upon receipt of the C_MMS_CONNECT-ind primitive the PP application shall issue a M_MMS_SEND_REQ-req primitive which shall in the <<MMS-OBJ-HDR>> IE have the "Src. Data type" = "Multipart message parent - multiple messages" and which shall not include a "Multipart parent message identifier", thus initiating the Level 1 multipart message. It shall also in the <<MMS-GENERIC-HDR>> request a reply from the MCE. The <<MMS-EXT-HDR>> IE(s) shall not be included.

Upon receipt of the M_MMS_SEND_REQ-ind primitive with a positive command outcome the PP shall begin operation according to subclause C.8.3.1 (T.30 phase B.1).

C.8.2.2 FP side/IWU procedures

Upon receipt of the C_MMS_SETUP-ind primitive the FP shall initiate the G3 fax call setup (T.30 phase A) to the EE identified in the <<CALLED-PARTY-NUMBER>> information element (IE) of {CC-SETUP}. The IWU shall operate in accordance with the requirements for automatic operation at the calling fax station as specified in subclauses 3.1.3 and 3.1.4 of ITU-T Recommendation T.30 [14] (Operating methods 3 & 4). Facilities for manual operation at the calling fax station (i.e. at the PP or IWU) as specified in subclauses 3.1.1 and 3.1.2 of ITU-T Recommendation T.30 [14] (Operating methods 1 & 2) are for further study.

The IWU's actions towards the network shall comply with the requirements and procedures for binary coded signalling set out in ITU-T Recommendation T.30 [14] and taking its starting point in the procedures as T.30 node T on the flow diagrams. Upon detection of the EE answering the IWU shall issue a C_MMS_CONNECT-req primitive. It shall then wait for receipt of the M_MMS_SEND_REQ-ind primitive upon which it shall send the CNG tone to the EE as specified in ITU-T Recommendation T.30 [14], including any necessary repetitions.

Upon detection of the CED signal or a HDLC frame the IWU shall issue a M_MMS_SEND_RPY-req primitive which shall in the <<MMS-GENERIC-HDR>> IE have the "Command Outcome" = one of the 3 "MMS Send Request (MMS-SEND-REQ) granted... " codings. The FP shall then begin operation according to subclause C.8.3.2 (T.30 phase B.1).

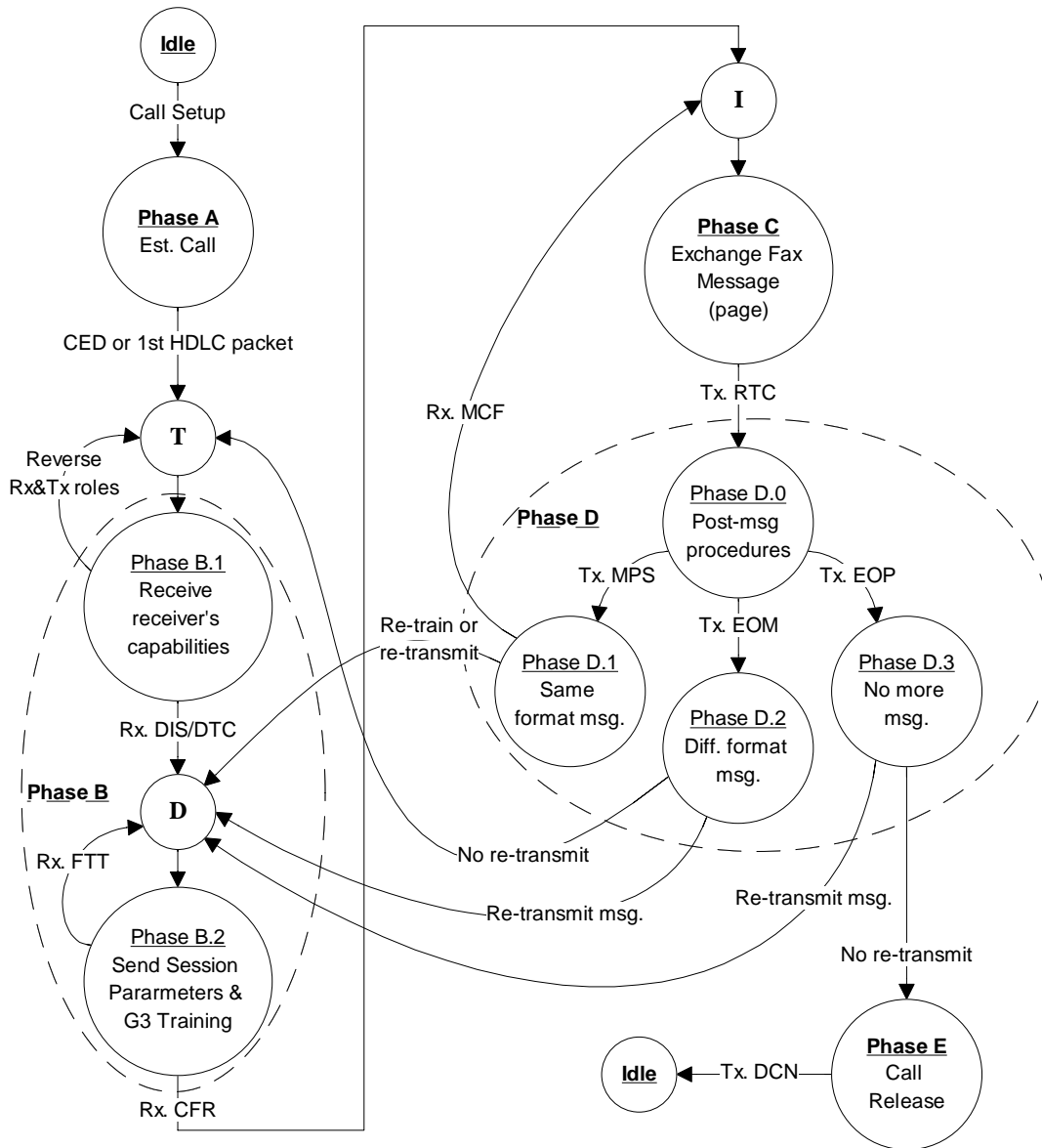

Figure C.2: Summary flow diagram showing the T.30 fax call phases on the transmit side

C.8.3 Service capability identification procedures (T.30 phase B.1)

All procedures in this phase are accomplished through the M-MMS primitives and messages.

C.8.3.1 PP side procedures

The PP shall not send the <<MMS-EXT-HDR>> IE(s) in any MMS commands or replies unless the optional procedure in subclause C.8.3.1.1 has been successfully invoked.

The procedures in this subclause shall be implemented (if appropriate) in the order in which they are specified.

C.8.3.1.1 Retrieval of FP and EE capabilities (Optional)

This optional procedure shall only be used if Option O.1 or Option O.3 is supported and the features associated with these options are required.

The PP application shall issue a M_MMS_EXT_CMD-req primitive which shall in the <<MMS-GENERIC-HDR>> IE have the "Ext. Command type" = "Retrieve End Entity capabilities". The PP shall then await receipt of the corresponding M_MMS_EXT_CMD_RPY-ind primitive. The FP and MCE mutually compatible capabilities shall be defined in the <<MMS-EXT-HDR>> IE(s) of this message as specified in subclauses C.6.1 and C.7.7. Prior to receipt of this primitive the PP shall also expect receipt, but not necessarily so, of a M_MMS_STATUS-ind primitive which has in the <<MMS-GENERIC-HDR>> IE the "Ext. Command type" = "New message(s) available for retrieval". Upon receipt of such a M_MMS_STATUS-ind primitive the PP shall set a "EE Message Waiting" flag to TRUE, if such a message is not received before the M_MMS_EXT_CMD_RPY-ind primitive then it shall set the "EE Message Waiting" flag to FALSE.

C.8.3.1.2 Fax message to transmit

This procedure shall only be implemented if the PP has a fax message to transmit. A typical message sequence for this phase is shown in figure C.3.

The PP application shall issue a M_MMS_SEND_REQ-req primitive which shall in the <<MMS-OBJ-HDR>> IE have the "Src. Data type" = "Multipart message parent - multiple messages" and which shall include a "Multipart parent message identifier" which references the "MMS message identifier" of the Level 1 multipart parent (initiated in subclause C.8.2.1). It shall also in the <<MMS-GENERIC-HDR>> request a reply from the MCE. This thus initiates the Level 2 multipart message and request the associated fax session parameters to be used for the transmission of the following fax pages or TFT files.

The "Service Sub-type" in the <<MMS-GENERIC-HDR>> IE shall indicate which fax service is being requested, STD, BFT, DTM, EDI or BTM (Services 1.1 to 1.5, clause C.2) or may be omitted to indicate the default STD service, see subclause C.7.2. The "Src User Data type" in the <<MMS-OBJ-HDR>> shall indicate a data type which is compatible with the requested service, see subclause C.7.6. The remaining requested fax session parameters may be specified by the <<MMS-EXT-HDR>> IE(s) if the optional procedure in subclause C.8.3.1.1 has been successfully invoked. If this IE is omitted the default parameters shall be used, see subclause C.7.7.

Following the issue of this M_MMS_SEND_REQ-req primitive the PP shall begin operation according to subclause C.8.4.1 (T.30 phase B.2).

C.8.3.1.3 Fax message to retrieve and none to transmit (Optional)

This procedure may be optionally implemented only if the PP does not have a fax message to transmit and it supports Option O.3 and it has a "EE Message Waiting" flag with the value TRUE. Note that retrieval of a fax message by a PP will result in an Incoming Fax message and therefore a typical message sequence for this phase is shown in figure C.20.

The PP application shall issue a M_MMS_SEND_REQ-req primitive which shall in the <<MMS-OBJ-HDR>> IE have the "Src. Data type" = "Multipart message end" and which shall include a "Multipart parent message identifier" which references the "MMS message identifier" of the Level 1 multipart parent (initiated in subclause C.8.2.1). It shall also in the <<MMS-GENERIC-HDR>> request a reply from the MCE. This thus explicitly terminates the Level 1 multipart message (and any active Level 2 multipart messages which are part of that Level 1 multipart message). The PP shall then await receipt of the corresponding M_MMS_SEND_RPY-ind primitive.

Following receipt of this M_MMS_SEND_RPY-ind primitive the PP application shall issue a M_MMS_RETRIEVE_REQ-req primitive which shall in the <<MMS-GENERIC-HDR>> request a reply from the MCE. The <<MMS-EXT-HDR>> IE(s) shall not be included. The PP shall then await receipt of the corresponding M_MMS_RETRIEVE_RPY-ind primitive which will initiate a new Level 1 multipart message.

The PP shall then await receipt of a M_MMS_EXT_CMD-ind primitive which has in the <<MMS-GENERIC-HDR>> IE the "Ext. Command type" = "Retrieve End Entity capabilities".

If the PP supports Option O.1 then the PP application shall, if it has a fax message(s) to send, issue a M_MMS_STATUS-req primitive which has in the <<MMS-GENERIC-HDR>> IE the "Ext. Command type" = "New message(s) available for retrieval". Whether this primitive is issued or not the PP application shall then issue the corresponding M_MMS_EXT_CMD_RPY-req primitive to the received M_MMS_EXT_CMD-ind primitive. This primitive shall give the parameters for the <<MMS-EXT-HDR>> IE(s) which shall define the set of fax capabilities of the PP as specified in subclauses C.6.1 and C.7.7. The PP shall then begin operation according to subclause C.9.4.2 (T.30 phase B.2 - Incoming Fax).

If the PP does not support Option O.1 then the PP application shall non-the-less issue the corresponding M_MMS_EXT_CMD_RPY-req primitive to the received M_MMS_EXT_CMD-ind primitive, as per the Unsupported MMS commands procedures specified in subclause A.1.3.11.1. The <<MMS-EXT-HDR>> IE(s) shall not be included. The PP shall then begin operation according to subclause C.9.4.2 (T.30 phase B.2 - Incoming Fax).

C.8.3.1.4 No Fax message to transmit or to retrieve

If the PP does not have a fax message to transmit or retrieve (procedure C.8.3.1.1 or C.8.3.1.2 not carried out) then the PP application shall issue a M_MMS_SEND_REQ-req primitive which shall in the <<MMS-OBJ-HDR>> IE have the "Src. Data type" = "Multipart message end" and which shall include a "Multipart parent message identifier" which references the "MMS message identifier" of the Level 1 multipart parent (initiated in subclause C.8.2.1). It shall also in the <<MMS-GENERIC-HDR>> request a reply from the MCE. This thus explicitly terminates the Level 1 multipart message (and any active Level 2 multipart messages which are part of that Level 1 multipart message).

Upon receipt of the M_MMS_SEND_RPY-ind primitive the PP shall begin operation according to subclause C.8.7.1 (T.30 phase E).

C.8.3.2 FP side/IWU procedures

The IWU's actions towards the network shall comply with the requirements and procedures for binary coded signalling set out in ITU-T Recommendation T.30 [14].

The IWU shall receive all the T.30 information frames (DIS and optionally NSF and CSI) and store the information received in these until instructed by the PP what to do with it and how to proceed. It shall also simultaneously await the receipt of commands from the PP and execute the following procedures as appropriate.

C.8.3.2.1 Retrieval of FP and EE capabilities

The following procedure shall be executed if a M_MMS_EXT_CMD-ind primitive is received which has in the <<MMS-GENERIC-HDR>> IE the "Ext. Command type" = "Retrieve End Entity capabilities".

The IWU shall, if necessary, wait before responding until it has received the T.30 DIS information field from the EE. The IWU shall then examine the "Transmitter - T.4 operation" (polling) bit of the DIS field and if this is set (=1) it shall issue a M_MMS_STATUS-req primitive which shall in the <<MMS-GENERIC-HDR>> IE have the "Ext. Command type" = "New message(s) available for retrieval". If the "Transmitter - T.4 operation" (polling) bit is not set the IWU shall not perform any associated action. The IWU shall then issue the appropriate M_MMS_EXT_CMD_RPY-req primitive to the received M_MMS_EXT_CMD-ind primitive. This primitive shall indicate the FP and MCE mutually compatible capabilities in the <<MMS-EXT-HDR>> IE(s) as specified in subclause C.7.7.

C.8.3.2.2 PP has a Fax message to transmit

The following procedure shall be executed if a M_MMS_SEND_REQ-ind primitive is received which has in the <<MMS-OBJ-HDR>> IE the "Src. Data type" = "Multipart message parent - multiple messages" and which has a "Multipart parent message identifier" which references the "MMS message identifier" of the Level 1 multipart parent (initiated by the PP in subclause C.8.2.1).

Following the receipt of this primitive the IWU shall begin operation according to subclause C.8.4.2 (T.30 phase B.2).

C.8.3.2.3 PP has no more fax messages to transmit

The following procedure shall be executed if a M_MMS_SEND_REQ-ind primitive is received which has in the <<MMS-OBJ-HDR>> IE the "Src. Data type" = "Multipart message end" and which has a "Multipart parent message identifier" which references the "MMS message identifier" of the Level 1 multipart parent (initiated by the PP in subclause C.8.2.1).

The IWU shall then respond with the appropriate M_MMS_SEND_RPY-req primitive to confirm the termination of the Level 1 multipart message (and any active Level 2 multipart messages which are part of that Level 1 multipart message).

Following the termination of this Level 1 multipart message the PP may decide to either retrieve a fax message or it may terminate the fax call. Therefore the IWU shall await the receipt of the next primitive. If this is a M_MMS_RETRIEVEREQ-ind the FP shall begin operation according to subclause C.8.3.2.4 below. If this is a C_MMS_RELEASE-ind the FP shall begin operation according to subclause C.8.7.2.1 (T.30 phase E).

C.8.3.2.4 PP wishes to retrieve a fax message

The following procedure shall be executed if a M_MMS_RETRIEVE_REQ-ind primitive is received which has in the <<MMS-OBJ-HDR>> IE the "Src. Data type" = "Multipart message parent - multiple messages" and which does not include a "Multipart parent message identifier". This thus initiates a new Level 1 multipart message.

The IWU shall examine the <<MMS-GENERIC-HDR>> IE and if it requests a reply from the MCE it shall issue a corresponding M_MMS_RETRIEVE_RPY-req primitive which shall in the <<MMS-GENERIC-HDR>> IE have the "Command Outcome" = one of the 3 "MMS Send Request (MMS-SEND-REQ) granted..." codings. This thus confirms the initiation of the new Level 1 multipart message.

The IWU shall then issue a M_MMS_EXT_CMD-ind primitive which shall in the <<MMS-GENERIC-HDR>> IE have the "Ext. Command type" = "Retrieve End Entity capabilities". The IWU shall then await receipt of the corresponding M_MMS_EXT_CMD_RPY-ind primitive. If the PP supports Option O.1 then this reply will be positive and the PP capabilities shall be defined in the <<MMS-EXT-HDR>> IE(s) of this message as specified in subclause C.7.7. Prior to receipt of this primitive the IWU shall also expect receipt, but not necessarily so, of a M_MMS_STATUS-ind primitive which has in the <<MMS-GENERIC-HDR>> IE the "Ext. Command type" = "New message(s) available for retrieval". Upon receipt of such a M_MMS_STATUS-ind primitive the IWU shall set a "PP Message Waiting" flag to TRUE, if such a message is not received before the M_MMS_EXT_CMD_RPY-ind primitive then it shall set the "PP Message Waiting" flag to FALSE.

If the PP does not support Option O.1 then the M_MMS_EXT_CMD_RPY-ind primitive will in the <<MMS-GENERIC-HDR>> IE have the "Command Outcome" = "Command (and/or Ext. Command) not supported" as per the Unsupported MMS commands procedures specified in subclause A.1.3.11.1. The IWU shall maintain, until otherwise notified by the PP, that the PP does not support Option O.1. While this Option is not supported the IWU shall not include the <<MMS-EXT-HDR>> IE(s) in any messages towards the PP.

Following the receipt of the M_MMS_EXT_CMD_RPY-ind primitive, regardless of the "Command Outcome", the IWU shall inform the EE of the combined, mutually compatible, capabilities of the PP and FP. The IWU's actions towards the network shall comply with the requirements and procedures for binary coded signalling set out in ITU-T Recommendation T.30 [14] and it shall take its starting point in the procedures as T.30 node R on the flow diagrams. The IWU shall therefore send binary coded signals such as NSC, CIG and DTC. In particular the content of the DTC field shall be defined by the retrieved PP capabilities (if any), "PP Message Waiting" flag and the capabilities of the IWU itself.

The IWU shall then wait for a response from the EE as per the ITU-T Recommendation T.30 [14] procedures and repeat its signals to the EE as may be required. Upon detecting a response the FP shall begin operation according to subclause C.9.4.1 (T.30 phase B.2 - Incoming Fax).

C.8.4 Service negotiation procedures (T.30 phase B.2)

All procedures in this phase are accomplished through the M-MMS primitives and messages.

During the T.30 phase B.2 negotiation phase (between the FP and the EE fax machine) the actual session parameters to be used will be agreed. If Option O.1 is supported then the PP desired parameters may have been transferred as part of the {MMS-SEND-REQ} message in the <<MMS-EXT-HDR>> IE(s). If this IE is omitted the default session parameters shall be used. Also see subclause C.7.7.

These parameters are however subject to negotiation with the EE. This negotiation process is entirely handled during Phase B.2 by the FP IWU without involvement from the PP. Once the IWU and EE have successfully negotiated the session parameters they shall be communicated to the PP as part of the {MMS-SEND-REQ} message in the <<MMS-EXT-HDR>> IE(s) only if Option O.1 is supported. Knowledge of these parameters by the PP is irrelevant to successful fax communications.

C.8.4.1 PP side procedures

The PP application shall await receipt of the M_MMS_SEND_RPY-ind primitive which corresponds to its last issued M_MMS_SEND_REQ-req primitive (in Phase B.1 or Phase D). This M_MMS_SEND_RPY-ind primitive shall indicate a multipart message of either Level 2 or 3 depending on whether it was initiated in Phase B.1 or Phase D respectively. Also see figure C.3 and C.5.

The PP application shall examine the <<MMS-GENERIC-HDR>> IE of the M_MMS_SEND_RPY-ind primitive and if it has "Command Outcome" = one of the 3 "MMS Send Request (MMS-SEND-REQ) granted..." codings the PP shall begin operation according to subclause C.8.5.1 (T.30 phase C). If any other "Command Outcome" coding is received the PP shall begin operation according to subclause C.8.7.1 (T.30 phase E).

C.8.4.2 FP side/IWU procedures

The IWU's actions towards the network shall comply with the requirements and procedures for binary coded signalling set out in T.30 and it shall take its starting point in these procedures as T.30 node D on the flow diagrams.

In accordance with these procedures the IWU shall send the binary coded signals for the "SET MODE" procedures such as TSI, DCS and TCF. The information content for these signals shall be derived from the parameters requested by the PP in last received Level 2 M_MMS_SEND_REQ-req primitive (see subclauses C.6.2 and C.8.3.1.2) and any subsequent knowledge that the IWU has gained regarding the EE and the communications channel between it and the EE, e.g. during the G3 Training sequence (TCF).

The IWU shall then await a response from the EE, repeating the "SET MODE" procedures if necessary, in accordance with the T.30 procedures. If the IWU receives the FTT signal it shall use the T.30 procedures to re-send "SET MODE" signals and attempt re-training until it receives the CFR signal.

NOTE: It is outside the scope of this ETS to specify the algorithms to be used for re-training, especially with regard to reducing the speed of the fax high speed modulation which is permitted within this procedure.

Upon receipt of the CFR signal from the EE the IWU shall issue a M_MMS_SEND_RPY-req primitive which corresponds to its last received M_MMS_SEND_REQ-ind primitive (in Phase B.1 or Phase D). This M_MMS_SEND_RPY-req primitive shall indicate a multipart message of either Level 2 or 3 depending on whether it was initiated in Phase B.1 or Phase D respectively. Also see figure C.3 and C.5. The IWU shall in the <<MMS-GENERIC-HDR>> IE of the M_MMS_SEND_RPY-req primitive indicate a "Command Outcome" = one of the 3 "MMS Send Request (MMS-SEND-REQ) granted..." codings. The FP shall then begin operation according to subclause C.8.5.2 (T.30 phase C).

If the IWU receives a FTT signal (Failure To Train) and decides (for reasons which are outside the scope of this ETS) not to attempt a re-training sequence the IWU shall issue the above M_MMS_SEND_RPY-req primitive indicating a "Command Outcome" = "Quality of service not available" coding. The IWU shall begin operation according to subclause C.8.7.2.1 (T.30 phase E).

If at any stage during these procedures the IWU has cause to implement the procedures starting at T.30 node C (except as a result of receiving FTT) or node B then the FP shall begin operation according to subclauses C.8.7.2.2 and C.8.7.2.3 respectively (T.30 phase E).

C.8.5 Message transmission procedures (T.30 phase C)

All procedures in this phase are accomplished through the M-MMS primitives and messages.

A typical message sequence for this phase is shown in figure C.3.

C.8.5.1 PP side procedures

Upon receipt of its M_MMS_SEND_RPY-ind to its last M_MMS_SEND_REQ-req primitive the PP shall within 4,5 seconds begin to send a single fax message (e.g. a single ITU-T Recommendation T.4 [15] coded page). This shall be accomplished by the PP issuing a M_MMS_SEND-req primitive which shall include a "Multipart parent message identifier" which references the "MMS message identifier" of the Level 2 multipart parent (initiated in subclause C.8.3.1.2). It shall also in the <<MMS-GENERIC-HDR>> not request any reply from either the MCE or the EE. This thus initiates a Level 3 message for the transmission of the fax message data.

The "Service Sub-type" in the <<MMS-GENERIC-HDR>> IE shall be coded identically to the message's Level 2 multipart parent. The "Src User Data type" in the <<MMS-OBJ-HDR>> shall indicate a data type which is compatible with the requested service, see subclause C.7.6. The <<MMS-EXT-HDR>> IE(s) shall not be included, regardless of whether Option O.1 is supported.

The <<USER-DATA>> IE of the {MMS-SEND} message shall be segmented during its transmission in accordance with the specifications given in subclause C.7.8.

Upon completion of sending the {MMS-SEND} message the PP shall begin operation according to subclause C.8.6.1 (T.30 phase D).

C.8.5.2 FP side/IWU procedures

Upon receipt of the Level 3 M_MMS_SEND-ind primitive and the segmented <<USER-DATA>> IE the IWU shall buffer the first 3 segments of the <<USER-DATA>> IE. It shall then begin streaming (i.e. transmitting while the data segments are still arriving) these segments to the EE. The IWU shall start this transmission with the G3 T.30 phase C training sequence and follow this with the first received <<USER-DATA>> segment. It will then transmit each subsequent segment to the EE as it finished transmission of the previous segment.

The throughput in the DECT PP to FP channel is ≤ 24 kbit/s, therefore there will not be any problem with underflow in the IWU buffer. The IWU shall use the LAPU flow-control mechanism to ensure that its buffer does not overflow. In the event that the IWU is not receiving enough data to meet the throughput requirements of the network, e.g. due to very severe error conditions on the radio channel, it may use padding/flags at the end of each fax scan line reduce the network throughput to a level which is compatible with the data throughput coming from the PP.

Having received and forwarded all the segments of the <<USER-DATA>> IE of the {MMS-SEND} message the FP shall begin operation according to subclause C.8.6.2 (T.30 phase D).

C.8.6 Post-message procedures (T.30 phase D)

All procedures in this phase are accomplished through the M-MMS primitives and messages.

Typical message sequences for this phase are shown in figures C.4 to C.10.

C.8.6.1 PP side procedures

C.8.6.1.1 More parts of the multi-part message to send (T.30 MPS)

This procedure shall only be implemented if the PP has more fax messages to transmit of the same type as the previous fax message (i.e. with the same fax session parameters). Typical message sequences for this phase are shown in figures C.4, C.5 and C.6.

The PP shall indicate to the FP that it has another single fax message (e.g. a single ITU-T Recommendation T.4 [15] coded page) to send of the same type as the previous by doing a SEND-REQ for this next message. This shall be accomplished by the PP issuing a M_MMS_SEND_REQ-req primitive which shall include a "Multipart parent message identifier" which references the "MMS message identifier" of the Level 2 multipart parent (initiated in subclause C.8.3.1.2). It shall also in the <<MMS-GENERIC-HDR>> request a reply from the MCE. This thus initiates a request to send a Level 3 message for the transmission of the fax message data.

The "Service Sub-type" in the <<MMS-GENERIC-HDR>> IE shall be coded identically to the message's Level 2 multipart parent. The "Src User Data type" in the <<MMS-OBJ-HDR>> shall indicate a data type which is compatible with the requested service, see subclause C.7.6. The <<MMS-EXT-HDR>> IE(s) shall not be included, regardless of whether Option O.1 is supported.

The PP shall await the receipt of the corresponding M_MMS_SEND_RPY-ind primitive. If the <<MMS-GENERIC-HDR>> IE of this primitive has a "Command Outcome" \neq "MMS Send Request (MMS-SEND-REQ) not granted, re-send previous MMS Object, if possible" coding the PP shall begin operation according to subclause C.8.4.1 (T.30 phase B.2).

If this "Command Outcome" coding is received (see figure C.6), the PP may choose, at its own discretion and without informing the FP, to re-send the previous fax message or to continue with the next page. In either case it shall make another SEND-REQ by beginning operation according to the beginning of this subclause (subclause C.8.6.1.1) (T.30 phase D, MPS).

C.8.6.1.2 Multi-part message finished but more fax messages to send (T.30 EOM)

This procedure shall only be implemented if the PP has more fax messages to transmit or retrieve which are different to the previous fax message (i.e. with different fax session parameters). Typical message sequences for this phase are shown in figures C.7 and C.8.

The PP shall indicate to the FP that it has another fax message (e.g. a TFT file or a fax message retrieval) to send or retrieve by requesting the termination of current Level 2 multipart message. This shall be accomplished by the PP issuing a M_MMS_SEND_REQ-req primitive which shall in the <<MMS-OBJ-HDR>> IE have the "Src. Data type" = "Multipart message end" and which shall include a "Multipart parent message identifier" which references the "MMS message identifier" of the Level 2 multipart parent (initiated in subclause C.8.3.1.2). It shall also in the <<MMS-GENERIC-HDR>> request a reply from the MCE. This thus explicitly terminates the Level 2 multipart message.

The PP shall await the receipt of the corresponding M_MMS_SEND_RPY-ind primitive. If the <<MMS-GENERIC-HDR>> IE of this primitive has a "Command Outcome" = "MMS Send Request (MMS-SEND-REQ) not granted, re-send previous MMS Object, if possible" coding then the PP may choose, at its own discretion, to re-send the previous fax message or to continue with the new fax message. If it chooses to re-send it shall make another SEND-REQ by beginning operation according to subclause C.8.6.1.1 (T.30 phase D, MPS). If it chooses to continue with the new fax message it shall repeat the request to terminate the Level 2 multipart message by beginning operation according to the beginning of this subclause (subclause C.8.6.1.2) (T.30 phase D, EOM).

NOTE: A multipart message is not considered to be terminated if the reply to the MMS-SEND-REQ which indicates the multipart message end does not have a successful Command Outcome.

If the <<MMS-GENERIC-HDR>> IE of the M_MMS_SEND_RPY-ind primitive has a "Command Outcome" ≠ "MMS Send Request (MMS-SEND-REQ) not granted, re-send previous MMS Object, if possible" coding the PP shall begin operation according to subclause C.8.3.1 (T.30 phase B.1).

C.8.6.1.3 Finished sending all messages and message parts (T.30 EOP)

This procedure shall only be implemented if the PP has no more fax messages to transmit or retrieve of any kind (i.e. if it wishes to release the fax call). Typical message sequences for this phase are shown in figures C.9 and C.10.

The PP shall indicate to the FP that it has no more fax messages to send or retrieve by requesting the termination of current Level 1 multipart message.

This shall be accomplished by the PP issuing a M_MMS_SEND_REQ-req primitive which shall in the <<MMS-OBJ-HDR>> IE have the "Src. Data type" = "Multipart message end" and which shall include a "Multipart parent message identifier" which references the "MMS message identifier" of the Level 1 multipart parent (initiated in subclause C.8.2.1). It shall also in the <<MMS-GENERIC-HDR>> request a reply from the MCE. This thus explicitly terminates the Level 1 multipart message (and any active Level 2 multipart messages which are part of that Level 1 multipart message).

The PP shall await the receipt of the corresponding M_MMS_SEND_RPY-ind primitive. If the <<MMS-GENERIC-HDR>> IE of this primitive has a "Command Outcome" = "MMS Send Request (MMS-SEND-REQ) not granted, re-send previous MMS Object, if possible" coding then the PP may choose, at its own discretion, to re-send the previous fax message or to release the fax call. If it chooses to re-send it shall make another SEND-REQ by beginning operation according to subclause C.8.6.1.1 (T.30 phase D, MPS). If it chooses to release the fax call it shall repeat the request to terminate the Level 1 multipart message by beginning operation according to the beginning of this subclause (subclause C.8.6.1.3) (T.30 phase D, EOP).

NOTE: A multipart message is not considered to be terminated if the reply to the MMS-SEND-REQ which indicates the multipart message end does not have a successful Command Outcome.

If the <<MMS-GENERIC-HDR>> IE of the M_MMS_SEND_RPY-ind primitive has a "Command Outcome" ≠ "MMS Send Request (MMS-SEND-REQ) not granted, re-send previous MMS Object, if possible" coding the PP shall begin operation according to subclause C.8.7.1 (T.30 phase E).

C.8.6.2 FP side/IWU procedures

As regards the IWU's actions towards the network it shall comply with the requirements and procedures for binary coded signalling set out in T.30.

The IWU shall await the receipt of commands from the PP and execute the following procedures as appropriate. Typical message sequences for this phase are shown in figures C.4 to C.10.

C.8.6.2.1 More parts of the multi-part message to send (T.30 MPS)

The following procedure shall be executed if a M_MMS_SEND_REQ-ind primitive is received which includes a "Multipart parent message identifier" which references the "MMS message identifier" of the Level 2 multipart parent (initiated by the PP in subclause C.8.3.2.2). This thus indicates a request to send a Level 3 message for the transmission of the fax message data of the same type as the previous fax message (i.e. with the same fax session parameters). Typical message sequences for this phase are shown in figures C.4, C.5 and C.6.

Upon receipt of this primitive the IWU shall send a MPS binary coded signal to the EE and await a response from the EE in accordance with the T.30 procedures.

If the EE responds with a MCF signal the IWU shall issue a M_MMS_SEND_RPY-req primitive which corresponds to the received M_MMS_SEND_REQ-ind primitive. The <<MMS-GENERIC-HDR>> IE of this primitive shall have a "Command Outcome" = one of the 3 "MMS Send Request (MMS-SEND-REQ) granted..." codings. The FP shall then begin operation according to subclause C.8.5.2 (T.30 phase C).

If the EE responds with a RTP signal the FP shall begin operation according to subclause C.8.4.2 (T.30 phase B.2).

If the EE responds with a RTN signal the IWU shall issue a M_MMS_SEND_RPY-req primitive which corresponds to the received M_MMS_SEND_REQ-ind primitive. The <<MMS-GENERIC-HDR>> IE of this primitive shall have a "Command Outcome" = "MMS Send Request (MMS-SEND-REQ) not granted, re-send previous MMS Object, if possible" coding. The IWU shall then await the receipt of another Level 3 M_MMS_SEND_REQ-ind primitive following which the FP shall begin operation according to subclause C.8.4.2 (T.30 phase B.2).

C.8.6.2.2 Multi-part message finished but more fax messages to send (T.30 EOM)

The following procedure shall be executed if a M_MMS_SEND_REQ-req primitive is received which in the <<MMS-OBJ-HDR>> IE has the "Src. Data type" = "Multipart message end" and which shall include a "Multipart parent message identifier" which references the "MMS message identifier" of the Level 2 multipart parent (initiated in subclause C.8.3.1.2). This thus explicitly requests the termination the Level 2 multipart message so that the PP may transmit or retrieve more fax messages which are different to the previous fax message (i.e. with different fax session parameters). Typical message sequences for this phase are shown in figures C.7 and C.8.

Upon receipt of this primitive the IWU shall send a EOM binary coded signal to the EE and await a response from the EE in accordance with the ITU-T Recommendation T.30 [14] procedures.

If the EE responds with a MCF or RTP signal the IWU shall issue a M_MMS_SEND_RPY-req primitive which corresponds to the received M_MMS_SEND_REQ-ind primitive. The <<MMS-GENERIC-HDR>> IE of this primitive shall have a "Command Outcome" = one of the 3 "MMS Send Request (MMS-SEND-REQ) granted..." codings. The FP shall then begin operation according to subclause C.8.3.2 (T.30 phase B.1).

If the EE responds with a RTN signal the IWU shall issue a M_MMS_SEND_RPY-req primitive which corresponds to the received M_MMS_SEND_REQ-ind primitive. The <<MMS-GENERIC-HDR>> IE of this primitive shall have a "Command Outcome" = "MMS Send Request (MMS-SEND-REQ) not granted, re-send previous MMS Object, if possible" coding. The IWU shall then await the receipt of the next command primitive from the PP.

If the next command from the PP is a Level 3 M_MMS_SEND_REQ-ind primitive the FP shall begin operation according to subclause C.8.4.2 (T.30 phase B.2).

If the next command from the PP is a repeat of the M_MMS_SEND_REQ-ind primitive request to terminate the Level 2 multipart message then the IWU shall issue a M_MMS_SEND_RPY-req primitive which corresponds to the received M_MMS_SEND_REQ-ind primitive. The <<MMS-GENERIC-HDR>> IE of this primitive shall have a "Command Outcome" = one of the 3 "MMS Send Request (MMS-SEND-REQ) granted..." codings. The FP shall then begin operation according to subclause C.8.3.2 (T.30 phase B.1).

C.8.6.2.3 Finished sending all messages and message parts (T.30 EOP)

The following procedure shall be executed if a M_MMS_SEND_REQ-req primitive is received which in the <<MMS-OBJ-HDR>> IE has the "Src. Data type" = "Multipart message end" and which shall include a "Multipart parent message identifier" which references the "MMS message identifier" of the Level 1 multipart parent (initiated in subclause C.8.2.1). This thus explicitly requests the termination the Level 1 multipart message to indicate that the PP has no more fax messages to transmit or retrieve of any kind (i.e. if it wishes to release the fax call). Typical message sequences for this phase are shown in figures C.9 and C.10.

Upon receipt of this primitive the IWU shall send a EOP binary coded signal to the EE and await a response from the EE in accordance with the ITU-T Recommendation T.30 [14] procedures.

If the EE responds with a MCF or RTP signal the IWU shall issue a M_MMS_SEND_RPY-req primitive which corresponds to the received M_MMS_SEND_REQ-ind primitive. The <<MMS-GENERIC-HDR>> IE of this primitive shall have a "Command Outcome" = one of the 3 "MMS Send Request (MMS-SEND-REQ) granted... " codings. The FP shall then begin operation according to subclause C.8.7.2.1 (T.30 phase E).

If the EE responds with a RTN signal the IWU shall issue a M_MMS_SEND_RPY-req primitive which corresponds to the received M_MMS_SEND_REQ-ind primitive. The <<MMS-GENERIC-HDR>> IE of this primitive shall have a "Command Outcome" = "MMS Send Request (MMS-SEND-REQ) not granted, re-send previous MMS Object, if possible" coding. The IWU shall then await the receipt of the next command primitive from the PP.

If the next command from the PP is a Level 3 M_MMS_SEND_REQ-ind primitive the FP shall begin operation according to subclause C.8.4.2 (T.30 phase B.2).

If the next command from the PP is a repeat of the M_MMS_SEND_REQ-ind primitive request to terminate the Level 1 multipart message then the IWU shall issue a M_MMS_SEND_RPY-req primitive which corresponds to the received M_MMS_SEND_REQ-ind primitive. The <<MMS-GENERIC-HDR>> IE of this primitive shall have a "Command Outcome" = one of the 3 "MMS Send Request (MMS-SEND-REQ) granted... " codings. The FP shall then begin operation according to subclause C.8.7.2.1 (T.30 phase E).

C.8.7 Call release procedures (T.30 phase E)

All procedures in this phase are accomplished through the C-MMS primitives and messages.

Typical message sequences for this phase are shown in figures C.9 and C.8.10.

C.8.7.1 PP side procedures

The PP application shall issue a C_MMS_RELEASE-req primitive and await the response of the appropriate C_MMS_RELEASE-cfm primitive in accordance with the procedures set out in ETS 300 175-5 [5], subclause 9.5.1.

C.8.7.2 FP side/IWU procedures

C.8.7.2.1 PP initiated normal release

Upon receipt of the C_MMS_RELEASE-ind primitive the IWU shall send a DCN binary coded signal to the EE and subsequently release the call to the EE in accordance with the ITU-T Recommendation T.30 [14] procedures. The IWU shall then issue the corresponding C_MMS_RELEASE-res primitive in accordance with the procedures set out in ETS 300 175-5 [5], subclause 9.5.1 to indicate to the PP the completion of the release procedure.

C.8.7.2.2 FP initiated orderly release

The IWU shall send a DCN binary coded signal to the EE and subsequently release the call the EE in accordance with the ITU-T Recommendation T.30 [14] procedures. The IWU shall then issue a C_MMS_REJECT-req primitive in accordance with the procedures set out in ETS 300 175-5 [5], subclause 9.5.2 to indicate to the PP that the fax call has been released.

C.8.7.2.3 FP initiated abnormal release

The IWU shall release the call to the EE without sending a DCN binary coded signal. The IWU shall then issue a C_MMS_REJECT-req primitive in accordance with the procedures set out in ETS 300 175-5 [5], subclause 9.5.2 to indicate to the PP that the fax call has been released.

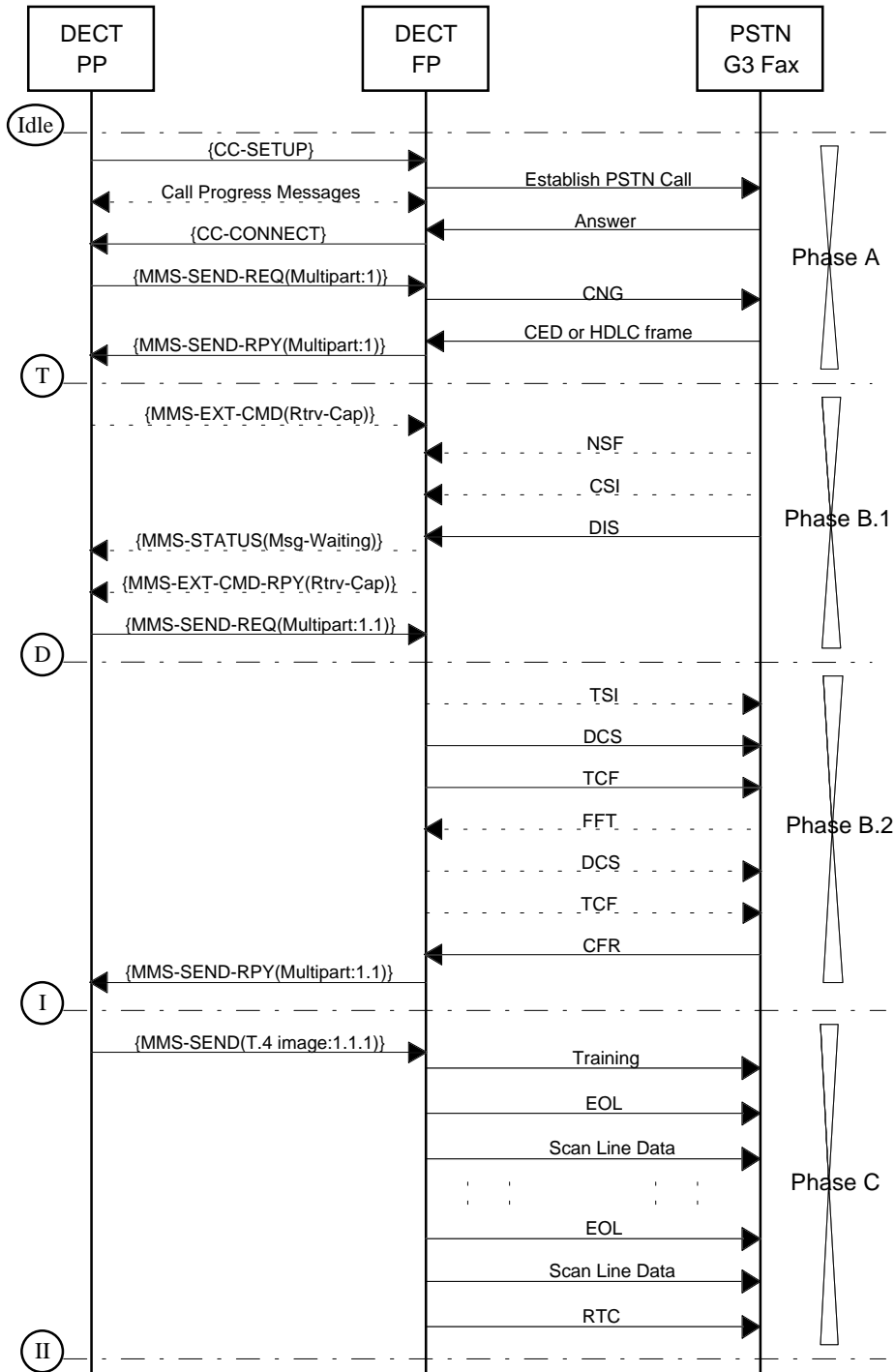

Figure C.3: Example message flows from phase A through to phase C

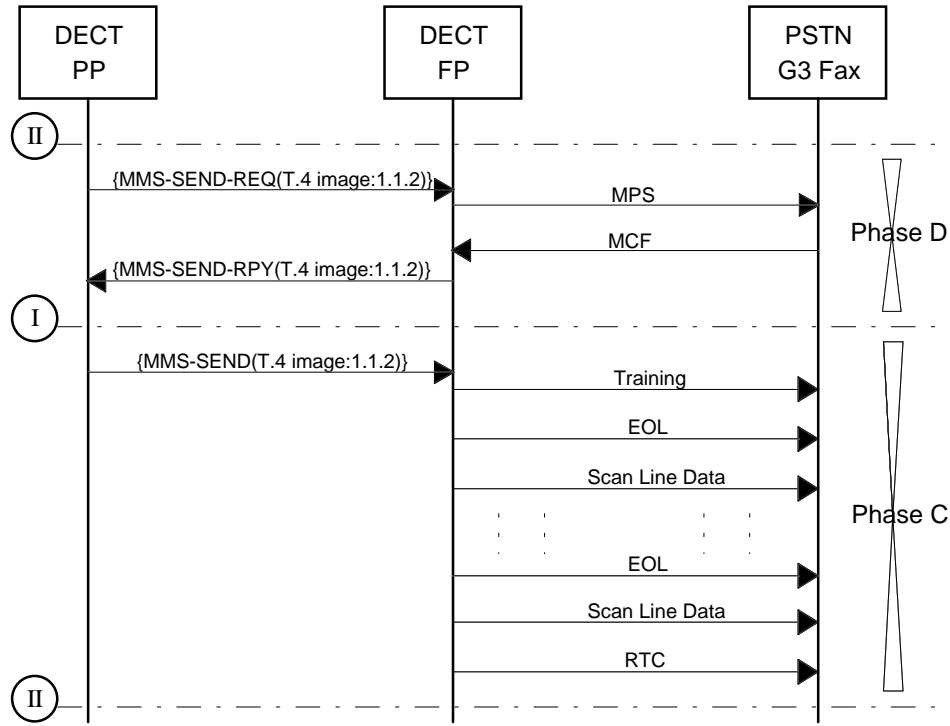

Figure C.4: Example message flows from phase D back to phase C

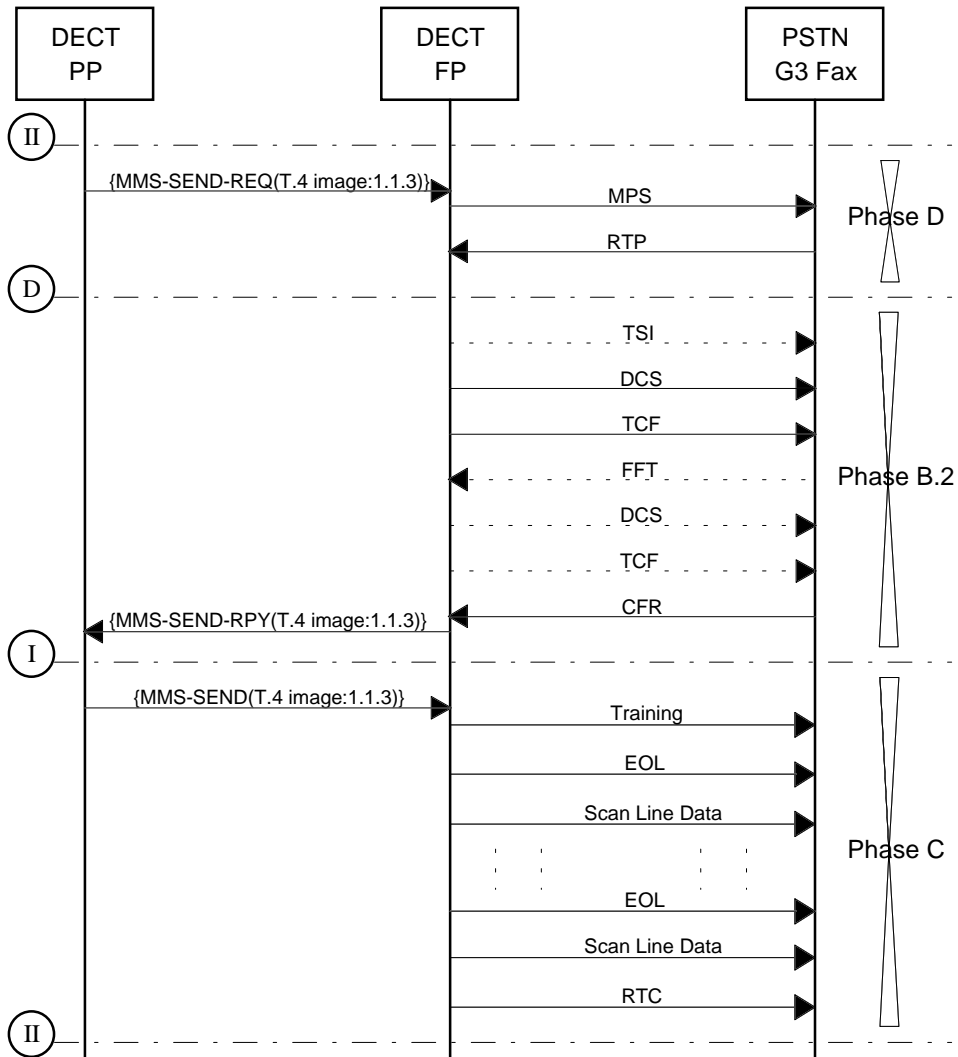

Figure C.5: Example message flows from phase D to phase B (re-training) and back to phase C

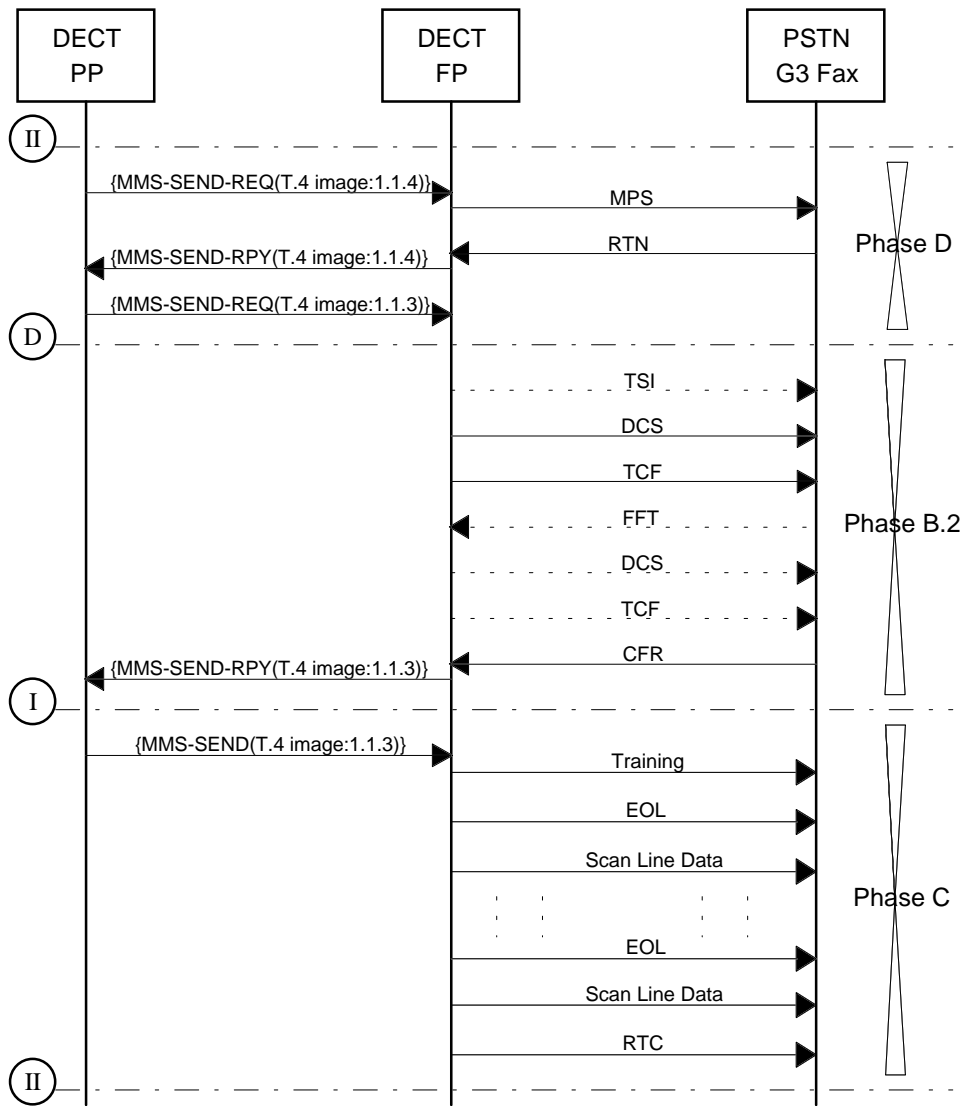

Figure C.6: Example message flows from phase D to phase B (re-transmission) and back to phase C

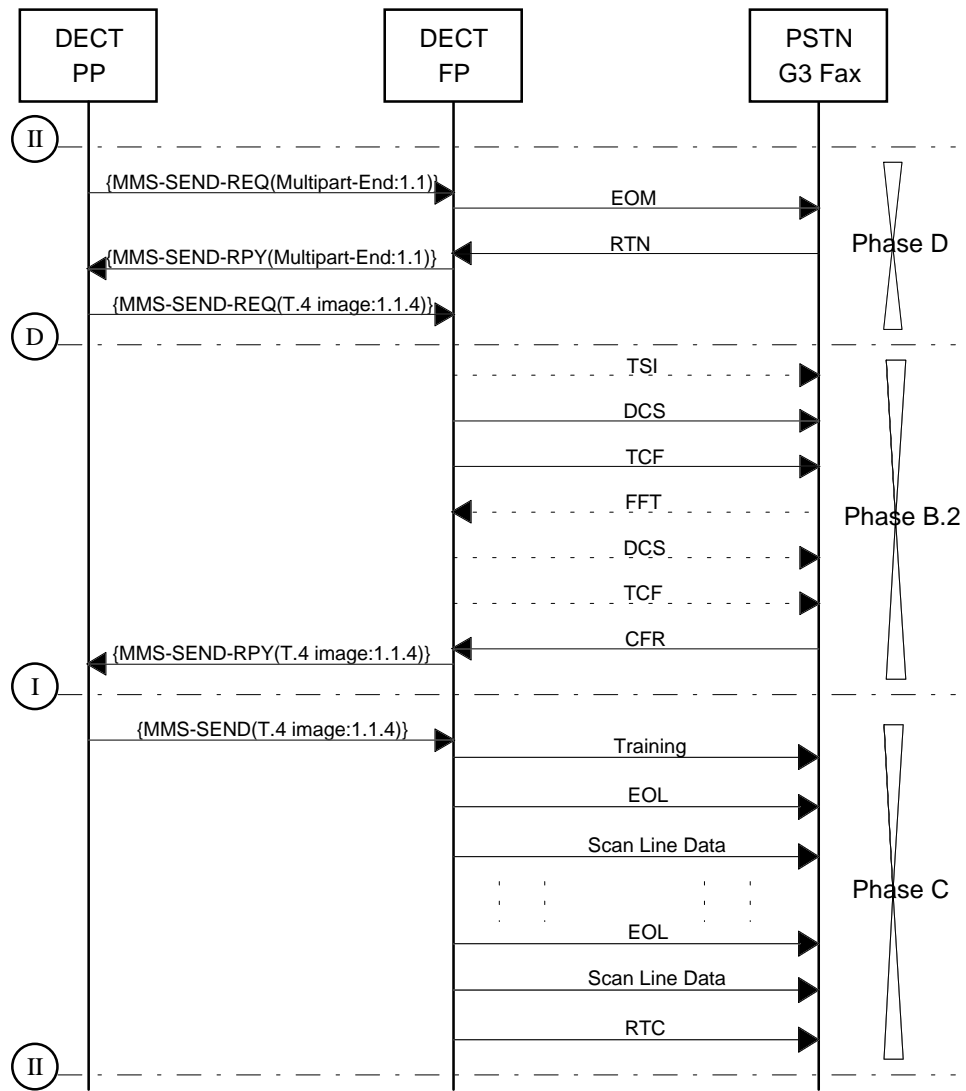

Figure C.7: Example message flows from phase D to phase B (different fax message) and back to phase C for re-transmission of previous page

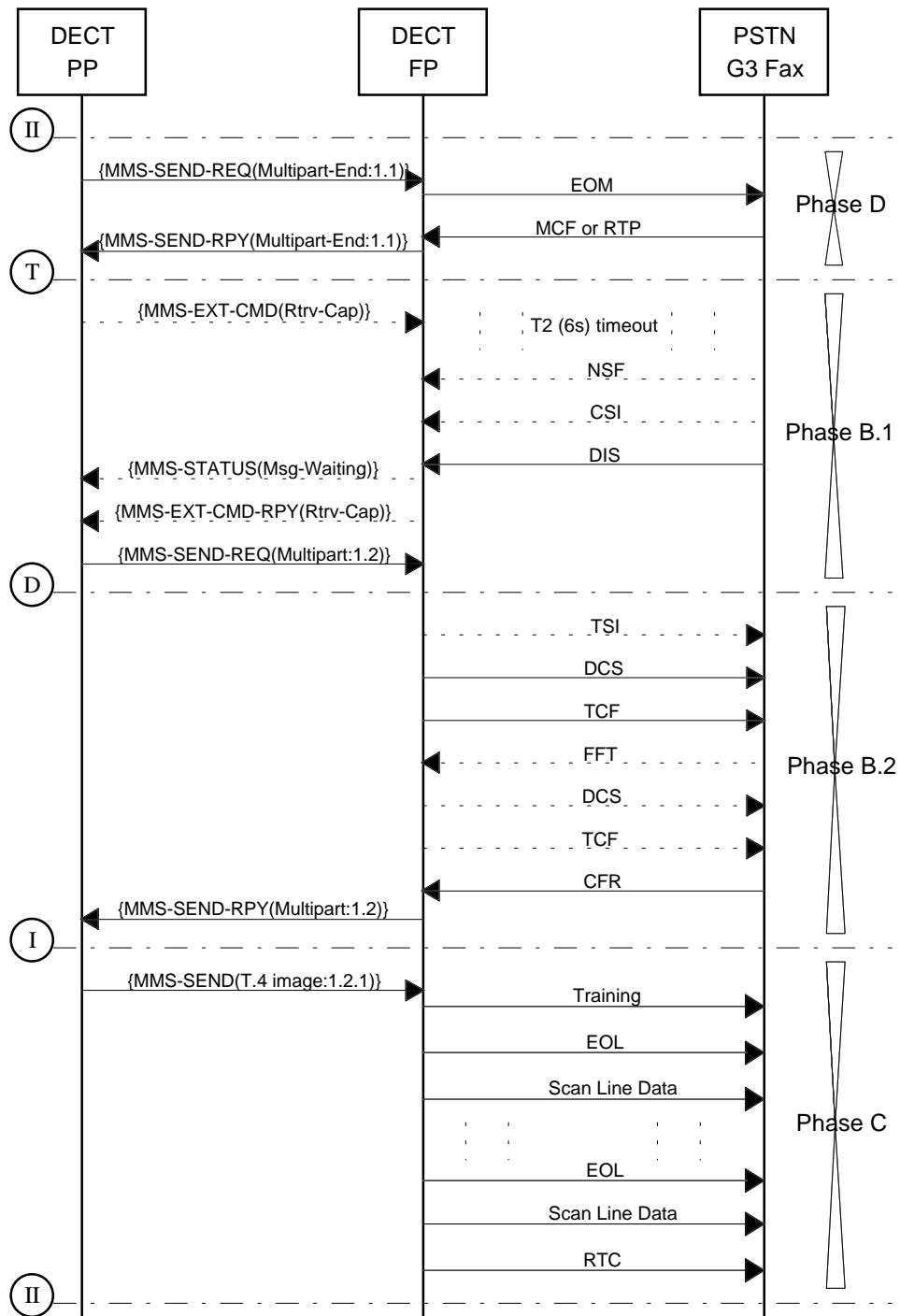

Figure C.8: Example message flows from phase D to phase B (different fax message) and back to phase C

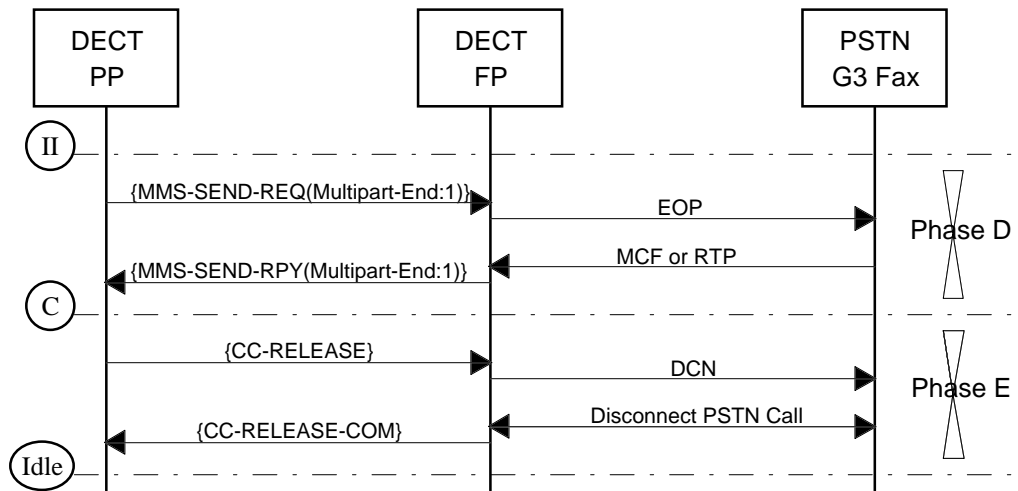

Figure C.9: Example message flows from phase D to phase E (no re-transmission requested)

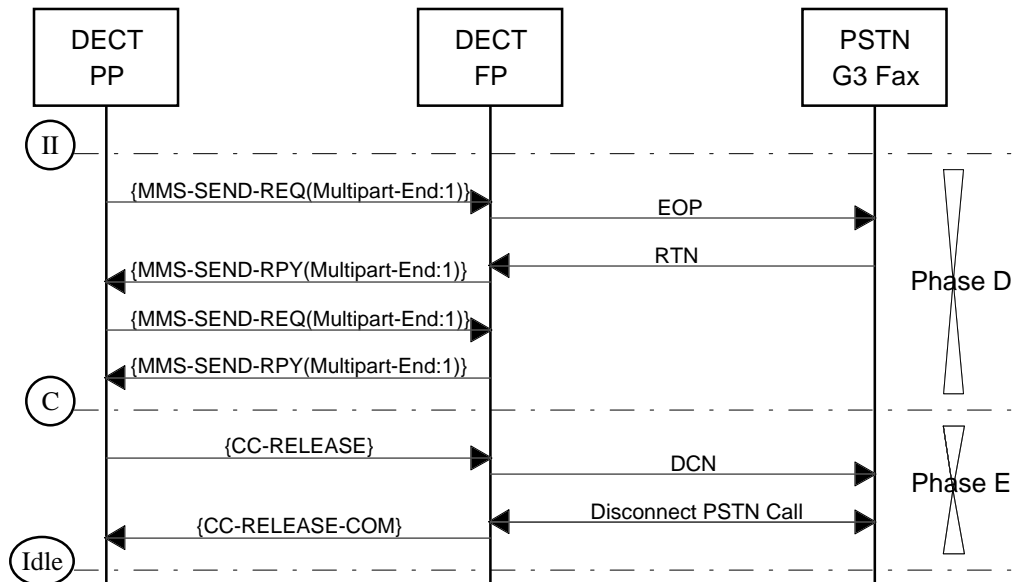

Figure C.10: Example message flows from phase D to phase E (re-transmission requested but not carried out)

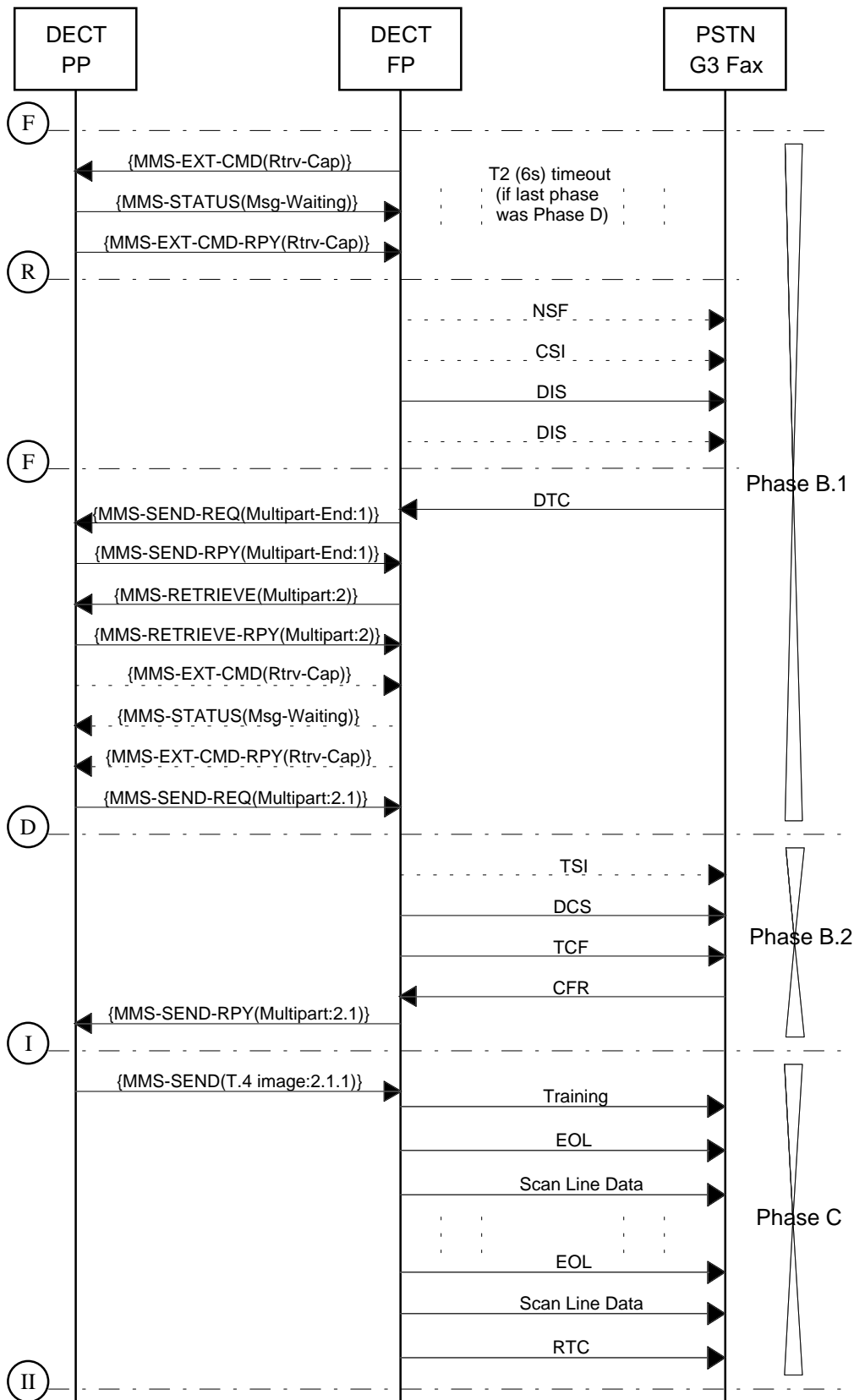

Figure C.11: Example message flows from phase B (incoming fax message/call) to phase B and C (outgoing fax message) (option O.2 - outgoing fax via fax polling)

C.9 Interworking procedures - incoming fax service

The interworking procedures in this annex are based on the reference configuration shown in figure C.12. It may be noted that this figure gives the example of a windows based ITU-T Recommendation T.611 [22] fax application in the PP. However the fax application could just as easily be a standard scanning and printing based fax machine or even an IWU which connects the MMSP to a standard Class 1/2 fax modem for use in RLL type applications. It may also be noted such an IWU (fax modem + IWU), like the FP IWU, may be very easily implemented using a standard Class 1/2 fax modem because of the similarity between Class fax commands and the MMS commands.

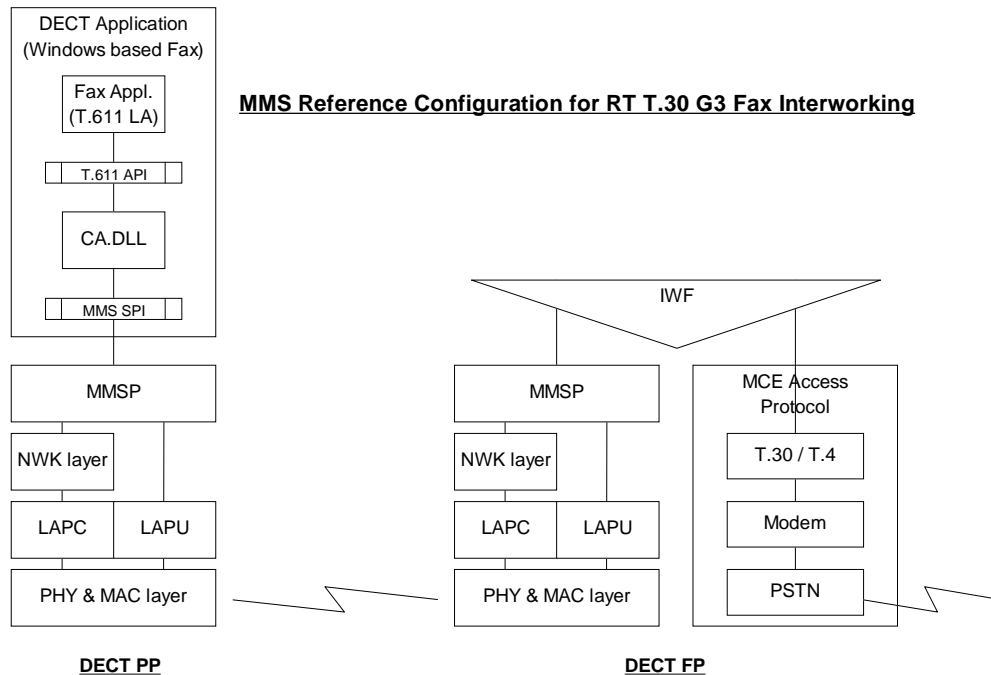

Figure C.12: DECT MMS to real-time T.30 G3 fax interworking

The typical message sequence diagrams showing progressions through and within all the phases of a fax call (phase A through to phase E) are shown in figures C.13 to C.20. These diagrams are informative only for the purposes of illustrating how the procedures specified in this clause can operate.

C.9.1 General procedures

The general procedures for the Incoming Fax service shall be identical to those described for the Outgoing Fax service in subclause C.8.1.

C.9.2 Call setup procedures (T.30 phase A)

The procedures in this phase are accomplished through a combination of C-MMS and M-MMS primitives and messages.

C.9.2.1 FP side/IWU procedures

The IWU shall operate in accordance with the requirements for automatic operation at the calling fax station as specified in subclauses 3.1.2 and 3.1.4 of ITU-T Recommendation T.30 [14] (Operating methods 2 & 4). Facilities for manual operation at the calling fax station (i.e. at the PP or IWU) as specified in subclauses 3.1.1 and 3.1.3 of ITU-T Recommendation T.30 [14] (Operating methods 1 & 3) are for further study.

The IWU's actions towards the network shall comply with the requirements and procedures for binary coded signalling set out in ITU-T Recommendation T.30 [14].

Upon detection of an incoming fax call the FP shall initiate an incoming MMS call to the PP using the procedures specified in clause 9 of this ETS by reference to the C.2 Data Service Profile (ETS 300 651 [13]). These procedures specify the use of either GAP-like call control procedures or Packet Mode procedures depending on whether call progress information and/or digit by digit dialling are required.

Regardless of which procedures are used the <<IWU-ATTRIBUTES>> information element shall be included with the Coding Standard (octet 3, bits 6-7) = "Profile defined coding" and the Profile (octet 3 bits 1-5) = "F data profile". The remainder of the <<IWU-ATTRIBUTES>> octets shall be coded as specified in subclause C.7.1.

Upon receipt of the C_MMS_CONNECT-ind primitive the IWU shall answer the incoming fax call and issue a C_MMS_CONNECT-res primitive. It shall then await receipt of the CNG signal and when this is detected it shall issue a M_MMS_SEND_REQ-req primitive which shall in the <<MMS-OBJ-HDR>> IE have the "Src. Data type" = "Multipart message parent - multiple messages" and which shall not include a "Multipart parent message identifier", thus initiating the Level 1 multipart message. It shall also in the <<MMS-GENERIC-HDR>> request a reply from the MCE. The <<MMS-EXT-HDR>> IE(s) shall not be included.

Upon receipt of the M_MMS_SEND_REQ-ind primitive with a positive command outcome the IWU shall generate the CED signal. It shall then begin operation according to subclause C.9.3.1 (T.30 phase B.1).

C.9.2.2 PP side procedures

These procedures are the equivalent of the procedures for automatic operation at the called fax station as specified in subclauses 3.1.2 and 3.1.4 of ITU-T Recommendation T.30 [14] (Operating methods 2 & 4). Facilities for manual operation at the calling fax station (i.e. at the PP or IWU) as specified in subclauses 3.1.1 and 3.1.3 of ITU-T Recommendation T.30 [14] (Operating methods 1 & 3) are for further study.

Upon receipt of the C_MMS_SETUP-ind primitive the PP shall follow the required call setup procedures as specified in clause 9 of this ETS. After issuing the C_MMS_CONNECT-req primitive the PP application shall await receipt of the C_MMS_CONNECT-cfm primitive.

The PP application shall then await receipt of the M_MMS_SEND_REQ-ind primitive and reply by issuing a M_MMS_SEND_RPY-req primitive which shall in the <<MMS-GENERIC-HDR>> IE have the "Command Outcome" = one of the 3 "MMS Send Request (MMS-SEND-REQ) granted..." codings. The PP shall then begin operation according to subclause C.9.3.2 (T.30 phase B.1).

C.9.3 Service capability identification procedures (T.30 phase B.1)

All procedures in this phase are accomplished through the M-MMS primitives and messages.

C.9.3.1 FP side/IWU procedures

The FP shall not send the <<MMS-EXT-HDR>> IE(s) in any MMS commands or replies unless the IWU has verified that the PP supports Option O.1 via the procedure in subclause C.9.3.1.1.

The procedures in this subclause shall be implemented (if appropriate) in the order in which they are specified.

C.9.3.1.1 Retrieval of PP capabilities and transfer of PP/IWU capabilities to the EE

The retrieve of the PP capabilities procedure may be optionally supported by the PP depending on whether Option O.1 or Option O.2 is supported and whether the features associated with these options are required.

The IWU shall then issue a M_MMS_EXT_CMD-ind primitive which shall in the <<MMS-GENERIC-HDR>> IE have the "Ext. Command type" = "Retrieve End Entity capabilities". The IWU shall then await receipt of the corresponding M_MMS_EXT_CMD_RPY-ind primitive. If the PP supports Option O.1 then this reply will be positive and the PP capabilities shall be defined in the <<MMS-EXT-HDR>> IE(s) of this message as specified in subclauses C.6.1 and C.7.7. The IWU shall store these PP capabilities. Prior to receipt of this primitive the IWU shall also expect receipt, but not necessarily so, of a M_MMS_STATUS-ind primitive which has in the <<MMS-GENERIC-HDR>> IE the "Ext. Command type" = "New message(s) available for retrieval". Upon receipt of such a M_MMS_STATUS-ind primitive the IWU shall set a "PP Message Waiting" flag to TRUE, if such a message is not received before the M_MMS_EXT_CMD_RPY-ind primitive then it shall set the "PP Message Waiting" flag to FALSE.

If the PP does not support Option O.1 then the M_MMS_EXT_CMD_RPY-ind primitive will in the <<MMS-GENERIC-HDR>> IE have the "Command Outcome" = "Command (and/or Ext. Command) not supported" as per the Unsupported MMS commands procedures specified in subclause A.1.3.11.1. The IWU shall maintain, until otherwise notified by the PP, that the PP does not support Option O.1. While this Option is not supported the IWU shall not include the <<MMS-EXT-HDR>> IE(s) in any messages towards the PP.

Following the receipt of the M_MMS_EXT_CMD_RPY-ind primitive, regardless of the "Command Outcome", the IWU shall inform the EE of the combined, mutually compatible, capabilities of the PP and FP. The IWU's actions towards the network shall comply with the requirements and procedures for binary coded signalling set out in ITU-T Recommendation T.30 [14] and it shall take its starting point in the procedures as ITU-T Recommendation T.30 [14] node R on the flow diagrams. The IWU shall therefore send binary coded signals such as NSF, CSI and DIS. In particular the content of the DIS field shall be defined by the retrieved PP capabilities (if any), "PP Message Waiting" flag and the capabilities of the IWU itself.

The IWU shall then wait for a response from the EE as per the ITU-T Recommendation T.30 [14] procedures and repeat its signals to the EE as may be required. If the response from EE is a DTC command then the FP shall begin operation according to subclause C.9.3.1.2 below. If it is a DCS command the FP shall begin operation according to subclause C.9.4.1 (T.30 phase B.2).

C.9.3.1.2 Retrieval of a fax message by the EE

This procedure may be optionally invoked by the EE provided the PP supports Option O.2 and it has a message for retrieval (i.e. to send). This condition is indicated at the FP by the "PP Message Waiting" flag and transferred to the EE in the DIS signal. Note that retrieval of a fax message by the EE will result in an Outgoing Fax message and therefore a typical message sequence for this phase is shown in figure C.11.

Upon receipt of the DTC command from the EE the IWU shall issue a M_MMS_SEND_REQ-req primitive which shall in the <<MMS-OBJ-HDR>> IE have the "Src. Data type" = "Multipart message end" and which shall include a "Multipart parent message identifier" which references the "MMS message identifier" of the Level 1 multipart parent (initiated in subclause C.9.2.1). It shall also in the <<MMS-GENERIC-HDR>> request a reply from the MCE. This thus explicitly terminates the Level 1 multipart message (and any active Level 2 multipart messages which are part of that Level 1 multipart message). The IWU shall then await receipt of the corresponding M_MMS_SEND_RPY-ind primitive.

Following receipt of this M_MMS_SEND_RPY-ind primitive the IWU shall issue a M_MMS_RETRIEVE_REQ-req primitive which shall in the <<MMS-GENERIC-HDR>> request a reply from the MCE. The <<MMS-EXT-HDR>> IE(s) shall not be included. The IWU shall then await receipt of the corresponding M_MMS_RETRIEVE_RPY-ind primitive which will initiate a new Level 1 multipart message.

The FP shall then begin operation according to subclause C.8.3.2.1 (T.30 phase B.1 - Outgoing Fax).

C.9.3.2 PP side procedures

C.9.3.2.1 Retrieval of PP capabilities (Optional)

The optional procedure to retrieve the PP capabilities shall only be used if Option O.1 or Option O.2 is supported and the features associated with these options are required. As per the Unsupported MMS commands procedures the PP is required to respond to the received M_MMS_EXT_CMD-ind primitive as specified below even if Option O.1 is not supported.

The PP shall await receipt of a M_MMS_EXT_CMD-ind primitive which has in the <<MMS-GENERIC-HDR>> IE the "Ext. Command type" = "Retrieve End Entity capabilities".

If the PP supports Option O.1 then the PP application shall, if it has a fax message(s) to send and it supports Option O.2, issue a M_MMS_STATUS-req primitive which has in the <<MMS-GENERIC-HDR>> IE the "Ext. Command type" = "New message(s) available for retrieval". Whether this primitive is issued or not the PP application shall then issue the corresponding M_MMS_EXT_CMD_RPY-req primitive to the received M_MMS_EXT_CMD-ind primitive. This primitive shall give the parameters for the <<MMS-EXT-HDR>> IE(s) which shall define the set of fax capabilities of the PP as specified in subclauses C.6.1 and C.7.7.

If the PP does not support Option O.1 then the PP application shall non-the-less issue the corresponding M_MMS_EXT_CMD_RPY-req primitive to the received M_MMS_EXT_CMD-ind primitive, as per the Unsupported MMS commands procedures specified in subclause A.1.3.11.1. The <<MMS-EXT-HDR>> IE(s) shall not be included.

The PP application shall then await the receipt of the next MMS primitive. If this is a M_MMS_SEND_REQ-ind primitive which in the <<MMS-OBJ-HDR>> IE has the "Src. Data type" = "Multipart message end" then the PP shall then begin operation according to subclause C.9.3.2.2 below. Otherwise the PP shall then begin operation according to subclause C.9.4.2 (T.30 phase B.2).

C.9.3.2.2 EE has no more fax messages to transmit

The PP shall await receipt of a M_MMS_SEND_REQ-ind primitive which has in the <<MMS-OBJ-HDR>> IE the "Src. Data type" = "Multipart message end" and which has a "Multipart parent message identifier" which references the "MMS message identifier" of the Level 1 multipart parent (initiated by the IWU in subclause C.9.2.1).

The PP shall then respond with the appropriate M_MMS_SEND_RPY-req primitive to confirm the termination of the Level 1 multipart message (and any active Level 2 multipart messages which are part of that Level 1 multipart message).

Following the termination of this Level 1 multipart message the EE/IWU may decide to either retrieve a fax message or it may terminate the fax call. Therefore the PP shall await the receipt of the next primitive. If this is a M_MMS_RETRIEVE_REQ-ind the PP shall begin operation according to subclause C.9.3.2.3 below. If this is a C_MMS_RELEASE-ind the PP shall begin operation according to subclause C.9.7.2.2 (T.30 phase E).

C.9.3.2.3 Retrieval of a fax message by the EE

The PP shall await receipt of a M_MMS_RETRIEVE_REQ-ind primitive which has in the <<MMS-OBJ-HDR>> IE the "Src. Data type" = "Multipart message parent - multiple messages" and which does not include a "Multipart parent message identifier". This thus initiates a new Level 1 multipart message.

The PP shall examine the <<MMS-GENERIC-HDR>> IE and if it requests a reply from the MCE it shall issue a corresponding M_MMS_RETRIEVE_RPY-req primitive which shall in the <<MMS-GENERIC-HDR>> IE have the "Command Outcome" = one of the 3 "MMS Send Request (MMS-SEND-REQ) granted..." codings. This thus confirms the initiation of the new Level 1 multipart message.

The PP shall then begin operation according to subclause C.8.3.1.1 (T.30 phase B.1 - Outgoing Fax).

C.9.4 Service negotiation procedures (T.30 phase B.2)

All procedures in this phase are accomplished through the M-MMS primitives and messages.

During the T.30 phase B.2 negotiation phase (between the FP and the EE fax machine) the actual session parameters to be used will be agreed. The combined PP and IWU capabilities will have been transferred (in the DIS frame) to the EE in Phase B.1. The EE will now propose the actual session parameters to be used in a DCS frame.

These parameters are however subject to negotiation with the IWU who may refuse them if, for example, they would lead to poor transmission quality with the given EE to IWU communications channel. This negotiation process is entirely handled during Phase B.2 by the FP IWU without involvement from the PP. Once the IWU and EE have successfully negotiated the session parameters they shall be communicated to the PP as part of the {MMS-SEND-REQ} message in the <<MMS-EXT-HDR>> IE(s) only if Option O.1 is supported. Knowledge of these parameters by the PP is irrelevant to successful fax communications.

C.9.4.1 FP side/IWU procedures

The IWU's actions towards the network shall comply with the requirements and procedures for binary coded signalling set out in ITU-T Recommendation T.30 [14].

In accordance with these procedures the IWU shall await the receipt of the binary coded signals for the "SET MODE" procedures such as TSI, DCS and TCF. The information content of these signals shall be stored for subsequent relay to the PP in the Level 2 M_MMS_SEND_REQ-req primitive if Option O.1 is supported. The IWU shall evaluate the TCF signal in accordance with the ITU-T Recommendation T.30 [14] procedures and shall respond within 2,25 seconds with a FTT if it does not find the signal acceptable.

Each time the IWU sends a FTT signal it shall wait for the new "SET MODE" procedure signals and evaluate the TCF signal until it finds it acceptable or until it times out, as specified in the ITU-T Recommendation T.30 [14] procedures.

NOTE: It is outside the scope of this ETS to specify the algorithms to be used for evaluating the TCF signal and determining its acceptability.

Upon receiving an acceptable TCF signal the IWU shall, based on the last received DCS signal, issue a M_MMS_SEND_REQ-req primitive which shall in the <<MMS-OBJ-HDR>> IE have the "Src. Data type" = "Multipart message parent - multiple messages" and which shall include a "Multipart parent message identifier". If the previous phase of the IWU was Phase B.1 then this identifier shall reference the "MMS message identifier" of the Level 1 multipart parent (initiated in subclause C.9.2.1). Thus initiating a new Level 2 multipart message and requesting the associated fax session parameters to be used for the transmission of the following fax pages or TFT files. If the previous phase of the IWU was Phase D then the multipart parent identifier shall reference the "MMS message identifier" of the Level 2 multipart parent (initiated in a previous Phase B.2, subclause C.9.4.1). This thus initiates a Level 3 message and requesting the associated fax session parameters to be used for the transmission of the following fax pages or TFT files.

The IWU shall in either case request a reply from the MCE in the <<MMS-GENERIC-HDR>>. The "Service Sub-type" in the <<MMS-GENERIC-HDR>> IE shall indicate which fax service is being requested, STD, BFT, DTM, EDI or BTM (Services 2.1 to 2.5, clause C.2) or may be omitted to indicate the default STD service, see subclause C.7.2. The "Src User Data type" in the <<MMS-OBJ-HDR>> shall indicate a data type which is compatible with the requested service, see subclause C.7.6. The remaining requested fax session parameters may be specified by the <<MMS-EXT-HDR>> IE(s) if the PP is known to support Option O.1. If this IE is omitted the default parameters shall be used, see subclause C.7.7.

The IWU shall then await receipt of the corresponding M_MMS_SEND_RPY-ind primitive. The IWU application shall examine the <<MMS-GENERIC-HDR>> IE of the M_MMS_SEND_RPY-ind primitive and if it has "Command Outcome" = one of the 3 "MMS Send Request (MMS-SEND-REQ) granted... " codings the IWU shall immediately return a CFR signal to the EE and begin operation according to subclause C.9.5.1 (T.30 phase C). If any other "Command Outcome" coding is received the IWU shall immediately respond with a FTT and begin operation according to the specification starting at the 3rd paragraph of this subclause (subclause 9.4.1).

If at any stage during these procedures the IWU has cause to implement the procedures starting at T.30 node C then the IWU shall send a DCN binary coded signal to the EE and the FP shall then begin operation according to subclause C.9.7.1.2 (T.30 phase E). If at any stage during these procedures the IWU has cause to implement the procedures starting at T.30 node B then the FP shall begin operation according to subclause C.9.7.1.3 (T.30 phase E).

C.9.4.2 PP side procedures

The PP shall await receipt of a M_MMS_SEND_REQ-ind primitive which has in the <<MMS-OBJ-HDR>> IE the "Src. Data type" = "Multipart message parent - multiple messages" and which has a "Multipart parent message identifier" which references the "MMS message identifier" of either the Level 1 multipart parent (initiated by the IWU in Phase A, subclause C.9.2.1) or Level 2 multipart parent (initiated by the IWU in Phase B.2, subclause C.9.4.1). This thus defines the proposed new fax session parameters. If the PP supports Option O.1 then detailed and explicit fax session parameters may be indicated by the M_MMS_SEND_REQ-ind primitive in the <<MMS-EXT-HDR>> IE(s). If this IE is omitted then the default parameters shall be assumed.

The PP application shall evaluate the fax session parameters and if it finds these acceptable it shall within 0,5 sec respond by issuing a corresponding M_MMS_SEND_RPY-req primitive. This M_MMS_SEND_RPY-req primitive shall indicate a multipart message of either Level 2 or 3 depending on which was received. Also see figure C.13 and C.15. The IWU shall in the <<MMS-GENERIC-HDR>> IE of the M_MMS_SEND_RPY-req primitive indicate a "Command Outcome" = one of the 3 "MMS Send Request (MMS-SEND-REQ) granted... " codings. The PP shall then begin operation according to subclause C.9.5.2 (T.30 phase C).

If the PP application does not find the fax session parameters acceptable it shall issue the above M_MMS_SEND_RPY-req primitive indicating the reason for the rejection in the "Command Outcome" coding. The IWU shall then again begin operation according to the start of this subclause (subclause C.9.4.2).

C.9.5 Message transmission procedures (T.30 phase C)

All procedures in this phase are accomplished through the M-MMS primitives and messages.

A typical message sequence for this phase is shown in figure C.13.

C.9.5.1 FP side/IWU procedures

The IWU's actions towards the network shall comply with the requirements and procedures for binary coded signalling set out in ITU-T Recommendation T.30 [14] and it shall take its starting point in these procedures as T.30 node F on the flow diagrams.

In accordance with these procedures the IWU shall await the receipt of the G3 T.30 phase C training sequence and the subsequent Scan Line Data or TFT file data. The IWU shall buffer all received fax data until sufficient data has been received to make up a segment of the <<USER-DATA>> IE as specified in subclause C.7.8. Each of these segments shall be buffered until it has been successfully delivered to the PP via LAPU.

When the first <<USER-DATA>> segment is available the IWU shall issue a M_MMS_SEND-req primitive which shall include a "Multipart parent message identifier" which references the "MMS message identifier" of the Level 2 multipart parent (initiated in subclause C.9.4.1). It shall also in the <<MMS-GENERIC-HDR>> not request any reply from either the MCE or the EE. This thus initiates a Level 3 message for the transmission of the fax message data.

The "Service Sub-type" in the <<MMS-GENERIC-HDR>> IE shall be coded identically to the messages Level 2 multipart parent. The "Src User Data type" in the <<MMS-OBJ-HDR>> shall indicate a data type which is compatible with the requested service, see subclause C.7.6. The <<MMS-EXT-HDR>> IE(s) shall not be included, regardless of whether Option O.1 is supported.

The IWU shall stream (i.e. transmit while the data segments are still arriving) the <<USER-DATA>> IE segments of the {MMS-SEND} message to the PP as soon as the segments become available.

The throughput in the DECT FP to PP channel is ≤ 24 kbit/s, the IWU shall therefore use the LAPU flow-control mechanism to temporarily halt the throughput in the DECT channel when <<USER-DATA>> segments are not yet available from the EE.

Having received and forwarded all the fax data as segments of <<USER-DATA>> in the {MMS-SEND} message the FP shall begin operation according to subclause C.9.6.1 (T.30 phase D).

C.9.5.2 PP side procedures

The PP shall await the receipt of the Level 3 M_MMS_SEND-ind primitive and the segmented <<USER-DATA>> IE.

Having received all the segments of <<USER-DATA>> in the {MMS-SEND} message the PP shall begin operation according to subclause C.9.6.2 (T.30 phase D).

C.9.6 Post-message procedures (T.30 phase D)

All procedures in this phase are accomplished through the M-MMS primitives and messages.

Typical message sequences for this phase are shown in figures C.14 to C.19.

C.9.6.1 FP side/IWU procedures

The IWU's actions towards the network shall comply with the requirements and procedures for binary coded signalling set out in ITU-T Recommendation T.30 [14], taking its starting point in these procedures as T.30 node F on the flow diagrams

C.9.6.1.1 More parts of the multi-part message to send (T.30 MPS)

This procedure shall only be implemented if the IWU receives a MPS binary coded signal from the EE indicating it has more fax messages to transmit of the same type as the previous fax message (i.e. with the same fax session parameters). Typical message sequences for this phase are shown in figures C.14, C.15 and C.16.

Upon receipt of the MPS signal the IWU shall issue a M_MMS_SEND_REQ-req primitive which shall include a "Multipart parent message identifier" which references the "MMS message identifier" of the Level 2 multipart parent (initiated in subclause C.9.4.1). It shall also in the <<MMS-GENERIC-HDR>> request a reply from the MCE. This thus initiates a request to send a Level 3 message for the transmission of the fax message data.

The "Service Sub-type" in the <<MMS-GENERIC-HDR>> IE shall be coded identically to the messages Level 2 multipart parent. The "Src User Data type" in the <<MMS-OBJ-HDR>> shall indicate a data type which is compatible with the requested service, see subclause C.7.6. The <<MMS-EXT-HDR>> IE(s) shall not be included, regardless of whether Option O.1 is supported.

The IWU shall await the receipt of the corresponding M_MMS_SEND_RPY-ind primitive. If the <<MMS-GENERIC-HDR>> IE of this primitive has a "Command Outcome" = "MMS Send Request (MMS-SEND-REQ) not granted, re-send previous MMS Object, if possible" coding the IWU shall return a T.30 RTN signal to the EE (see figure C.16) and begin operation according to subclause C.9.4.1 (T.30 phase B.2).

If a positive "Command Outcome" coding is received (see figure C.16), the IWU may choose, at its own discretion by algorithms which are outside the scope of this ETS and without informing the PP, to request either re-transmission of the fax message part (RTN), to request re-training (RTP) or the or to accept the fax message part and proceed to the next (MCF). The IWU may for example send a RTN or RTP if fax data was lost due to IWU buffering or due to detection of poor modem signal quality.

The IWU shall thus respond to the EE with either a T.30 RTN, RTP or MCF signal as it deems appropriate. If the IWU sent a RTN or RTP signal it shall begin operation according to subclause C.9.4.1 (T.30 phase B.2) (see figures C.15 and C.16). If the IWU sent a MCF signal it shall begin operation according to subclause C.9.5.1 (T.30 phase C) (see figure C.14).

C.9.6.1.2 Multi-part message finished but more fax messages to send (T.30 EOM)

This procedure shall only be implemented if the IWU receives an EOM binary coded signal from the EE indicating it has more fax messages to transmit or retrieve which are different to the previous fax message (i.e. with different fax session parameters). Typical message sequences for this phase are shown in figures C.17 and C.18.

Upon receipt of the EOM signal the IWU shall issue a M_MMS_SEND_REQ-req primitive which shall in the <<MMS-OBJ-HDR>> IE have the "Src. Data type" = "Multipart message end" and which shall include a "Multipart parent message identifier" which references the "MMS message identifier" of the Level 2 multipart parent (initiated in subclause C.9.4.1). It shall also in the <<MMS-GENERIC-HDR>> request a reply from the MCE. This thus explicitly terminates the Level 2 multipart message.

The IWU shall await the receipt of the corresponding M_MMS_SEND_RPY-ind primitive. If the <<MMS-GENERIC-HDR>> IE of this primitive has a "Command Outcome" = "MMS Send Request (MMS-SEND-REQ) not granted, re-send previous MMS Object, if possible" coding the IWU shall return a T.30 RTN signal to the EE (see figure C.17).

If a positive "Command Outcome" coding is received (see figure C.18), the IWU may choose, at its own discretion by algorithms which are outside the scope of this ETS and without informing the PP, to request either re-transmission of the fax message part (RTN), to request re-training (RTP) or the or to accept the fax message part and proceed to the next (MCF). The IWU may for example send a RTN or RTP if fax data was lost due to IWU buffering or due to detection of poor modem signal quality. The IWU shall thus respond to the EE with either a T.30 RTN, RTP or MCF signal as it deems appropriate.

The IWU shall then await a response from the EE as per the ITU-T Recommendation T.30 [14] procedures taking its starting point in these procedures as T.30 node F on the flow diagrams. If it receives a response before the 6 second time-out the IWU shall begin operation according to subclause C.9.4.1 (T.30 phase B.2) (see figure C.17).

If the IWU does not receive a response before the time-out and it sent a RTP or MCF signal to the EE then it shall begin operation according to subclause C.9.3.1.1 (T.30 phase B.1) (see figure C.18).

If the IWU does not receive a response before the time-out and it sent a RTN signal to the EE then it shall issue the above M_MMS_SEND_REQ-req primitive (again) to request the termination of the Level 2 multipart message. Upon receipt of the corresponding M_MMS_SEND_RPY-ind primitive it shall begin operation according to subclause C.9.3.1.1 (T.30 phase B.1) (see figure C.18).

C.9.6.1.3 Finished sending all messages and message parts (T.30 EOP)

This procedure shall only be implemented if the IWU receives an EOP binary coded signal from the EE indicating that it has no more fax messages to transmit or retrieve of any kind (i.e. if it wishes to release the fax call). A typical message sequence for this phase is shown in figure C.19.

Upon receipt of the EOP signal the IWU shall issue a M_MMS_SEND_REQ-req primitive which shall in the <<MMS-OBJ-HDR>> IE have the "Src. Data type" = "Multipart message end" and which shall include a "Multipart parent message identifier" which references the "MMS message identifier" of the Level 1 multipart parent (initiated in subclause C.9.2.1). It shall also in the <<MMS-GENERIC-HDR>> request a reply from the MCE. This thus explicitly terminates the Level 1 multipart message (and any active Level 2 multipart messages which are part of that Level 1 multipart message).

The IWU shall await the receipt of the corresponding M_MMS_SEND_RPY-ind primitive. If the <<MMS-GENERIC-HDR>> IE of this primitive has a "Command Outcome" = "MMS Send Request (MMS-SEND-REQ) not granted, re-send previous MMS Object, if possible" coding the IWU shall return a T.30 RTN signal to the EE.

If a positive "Command Outcome" coding is received the IWU may choose, at its own discretion by algorithms which are outside the scope of this ETS and without informing the PP, to request either re-transmission of the fax message part (RTN), to request re-training (RTP) or the or to accept the fax message part and proceed to the next (MCF). The IWU may for example send a RTN or RTP if fax data was lost due to IWU buffering or due to detection of poor modem signal quality. The IWU shall thus respond to the EE with either a T.30 RTN, RTP or MCF signal as it deems appropriate.

The IWU shall then await a response from the EE as per the ITU-T Recommendation T.30 [14] procedures taking its starting point in these procedures as T.30 node F on the flow diagrams.

If the IWU receives a DCN response and it sent a RTP or MCF signal to the EE then it shall begin operation according to subclause C.9.7.1.2 (T.30 phase E).

If the IWU receives a DCN response and it sent a RTN signal to the EE then it shall issue the above M_MMS_SEND_REQ-req primitive (again) to request the termination of the Level 2 multipart message. Upon receipt of the corresponding M_MMS_SEND_RPY-ind primitive it shall begin operation according to subclause C.9.7.1.2 (T.30 phase E).

If the IWU receives any other response it shall begin operation according to subclause C.9.4.1 (T.30 phase B.2).

C.9.6.2 PP side procedures

The PP shall await the receipt of commands from the FP and execute the following procedures as appropriate. Typical message sequences for this phase are shown in figures C.14 to C.19.

C.9.6.2.1 More parts of the multi-part message to send (T.30 MPS)

The following procedure shall be executed if a M_MMS_SEND_REQ-ind primitive is received which includes a "Multipart parent message identifier" which references the "MMS message identifier" of the Level 2 multipart parent (initiated by the PP in subclause C.9.4.2). This thus indicates a request to send a Level 3 message for the transmission of the fax message data of the same type as the previous fax message (i.e. with the same fax session parameters). Typical message sequences for this phase are shown in figures C.14, C.15 and C.16.

If the PP found the quality of the previous fax message part acceptable it shall issue a corresponding M_MMS_SEND_RPY-req primitive which shall in the <<MMS-GENERIC-HDR>> IE have a "Command Outcome" = one of the 3 "MMS Send Request (MMS-SEND-REQ) granted..." codings. The PP shall then begin operation according to subclause C.9.5.2 (T.30 phase C).

If the PP did not find the quality of the previous fax message part acceptable it shall issue a corresponding M_MMS_SEND_RPY-req primitive which shall in the <<MMS-GENERIC-HDR>> IE have a "Command Outcome" = "MMS Send Request (MMS-SEND-REQ) not granted, re-send previous MMS Object, if possible" coding. The PP shall then await the receipt of another Level 3 M_MMS_SEND_REQ-ind primitive following which the PP shall begin operation according to subclause C.9.4.2 (T.30 phase B.2).

C.9.6.2.2 Multi-part message finished but more fax messages to send (T.30 EOM)

The following procedure shall be executed if a M_MMS_SEND_REQ-req primitive is received which in the <<MMS-OBJ-HDR>> IE has the "Src. Data type" = "Multipart message end" and which shall include a "Multipart parent message identifier" which references the "MMS message identifier" of the Level 2 multipart parent (initiated in subclause C.9.4.2). This thus explicitly requests the termination the Level 2 multipart message so that the PP may transmit or retrieve more fax messages which are different to the previous fax message (i.e. with different fax session parameters). Typical message sequences for this phase are shown in figures C.17 and C.18.

If the PP found the quality of the previous fax message part acceptable it shall issue a corresponding M_MMS_SEND_RPY-req primitive which shall in the <<MMS-GENERIC-HDR>> IE have a "Command Outcome" = one of the 3 "MMS Send Request (MMS-SEND-REQ) granted..." codings. The PP shall then begin operation according to subclause C.9.3.2.1 (T.30 phase B.1).

If the PP did not find the quality of the previous fax message part acceptable it shall issue a corresponding M_MMS_SEND_RPY-req primitive which shall in the <<MMS-GENERIC-HDR>> IE have a "Command Outcome" = "MMS Send Request (MMS-SEND-REQ) not granted, re-send previous MMS Object, if possible" coding.

If the next command from the IWU is a Level 3 M_MMS_SEND_REQ-ind primitive the PP shall begin operation according to subclause C.9.4.2 (T.30 phase B.2).

If the next command from the IWU is a repeat of the M_MMS_SEND_REQ-ind primitive request to terminate the Level 2 multipart message then the PP shall issue a M_MMS_SEND_RPY-req primitive which corresponds to the received M_MMS_SEND_REQ-ind primitive. The <<MMS-GENERIC-HDR>> IE of this primitive shall have a "Command Outcome" = one of the 3 "MMS Send Request (MMS-SEND-REQ) granted..." codings. The PP shall then begin operation according to subclause C.9.3.2.1 (T.30 phase B.1).

C.9.6.2.3 Finished sending all messages and message parts (T.30 EOP)

The following procedure shall be executed if a M_MMS_SEND_REQ-req primitive is received which in the <<MMS-OBJ-HDR>> IE has the "Src. Data type" = "Multipart message end" and which shall include a "Multipart parent message identifier" which references the "MMS message identifier" of the Level 1 multipart parent (initiated in subclause C.9.2.1). This thus explicitly requests the termination the Level 1 multipart message to indicate that the PP has no more fax messages to transmit or retrieve of any kind (i.e. if it wishes to release the fax call). A typical message sequence for this phase is shown in figure C.19.

If the PP found the quality of the previous fax message part acceptable it shall issue a corresponding M_MMS_SEND_RPY-req primitive which shall in the <<MMS-GENERIC-HDR>> IE have a "Command Outcome" = one of the 3 "MMS Send Request (MMS-SEND-REQ) granted..." codings. The PP shall then begin operation according to subclause C.9.7.2.2 (T.30 phase E).

If the PP did not find the quality of the previous fax message part acceptable it shall issue a corresponding M_MMS_SEND_RPY-req primitive which shall in the <<MMS-GENERIC-HDR>> IE have a "Command Outcome" = "MMS Send Request (MMS-SEND-REQ) not granted, re-send previous MMS Object, if possible" coding.

If the next command from the IWU is a Level 3 M_MMS_SEND-REQ-ind primitive the PP shall begin operation according to subclause C.9.4.2 (T.30 phase B.2).

If the next command from the IWU is a repeat of the M_MMS_SEND_REQ-ind primitive request to terminate the Level 2 multipart message then the PP shall issue a M_MMS_SEND_RPY-req primitive which corresponds to the received M_MMS_SEND_REQ-ind primitive. The <<MMS-GENERIC-HDR>> IE of this primitive shall have a "Command Outcome" = one of the 3 "MMS Send Request (MMS-SEND-REQ) granted..." codings. The PP shall then begin operation according to subclause C.9.7.2.2 (T.30 phase E).

C.9.7 Call release procedures (T.30 phase E)

All procedures in this phase are accomplished through the C-MMS primitives and messages.

A typical message sequence for this phase is shown in figure C.19.

C.9.7.1 FP side/IWU procedures

C.9.7.1.1 PP initiated normal release

Upon receipt of the C_MMS_RELEASE-ind primitive the IWU shall send a DCN binary coded signal to the EE and subsequently release the call to the EE in accordance with the ITU-T Recommendation T.30 [14] procedures. The IWU shall then issue the corresponding C_MMS_RELEASE-res primitive in accordance with the procedures set out in ETS 300 175-5 [5], subclause 9.5.1 to indicate to the PP the completion of the release procedure.

C.9.7.1.2 EE/FP initiated orderly release

The IWU shall issue a C_MMS_RELEASE-req primitive in accordance with the procedures set out in ETS 300 175-5 [5], subclause 9.5.1 to indicate to the PP that the EE/FP wishes to release the fax call. The IWU shall then await receipt of the C_MMS_RELEASE-cfm primitive and upon its receipt it shall release the call to the EE, if this has not already been released by the EE.

NOTE: If the release was initiated by the EE then the IWU will already have received a DCN binary coded signal from the EE prior to implementing these procedures.

C.9.7.1.3 EE/FP initiated abnormal release

The IWU shall release the call to the EE, if this has not already been released by the EE. It shall not send a DCN binary coded signal. The IWU shall then issue a C_MMS_REJECT-req primitive in accordance with the procedures set out in ETS 300 175-5 [5], subclause 9.5.2 to indicate to the PP that the fax call has been released.

C.9.7.2 PP side procedures

C.9.7.2.1 PP initiated normal release

The PP application shall issue a C_MMS_RELEASE-req primitive and await the response of the appropriate C_MMS_RELEASE-cfm primitive in accordance with the procedures set out in ETS 300 175-5 [5], subclause 9.5.1.

C.9.7.2.2 EE/FP initiated orderly release

Upon receipt of a C_MMS_RELEASE-ind primitive the PP shall issue a C_MMS_RELEASE-res primitive and release all the resources associated with this call instance in accordance with the procedures set out in ETS 300 175-5 [5], subclause 9.5.1.

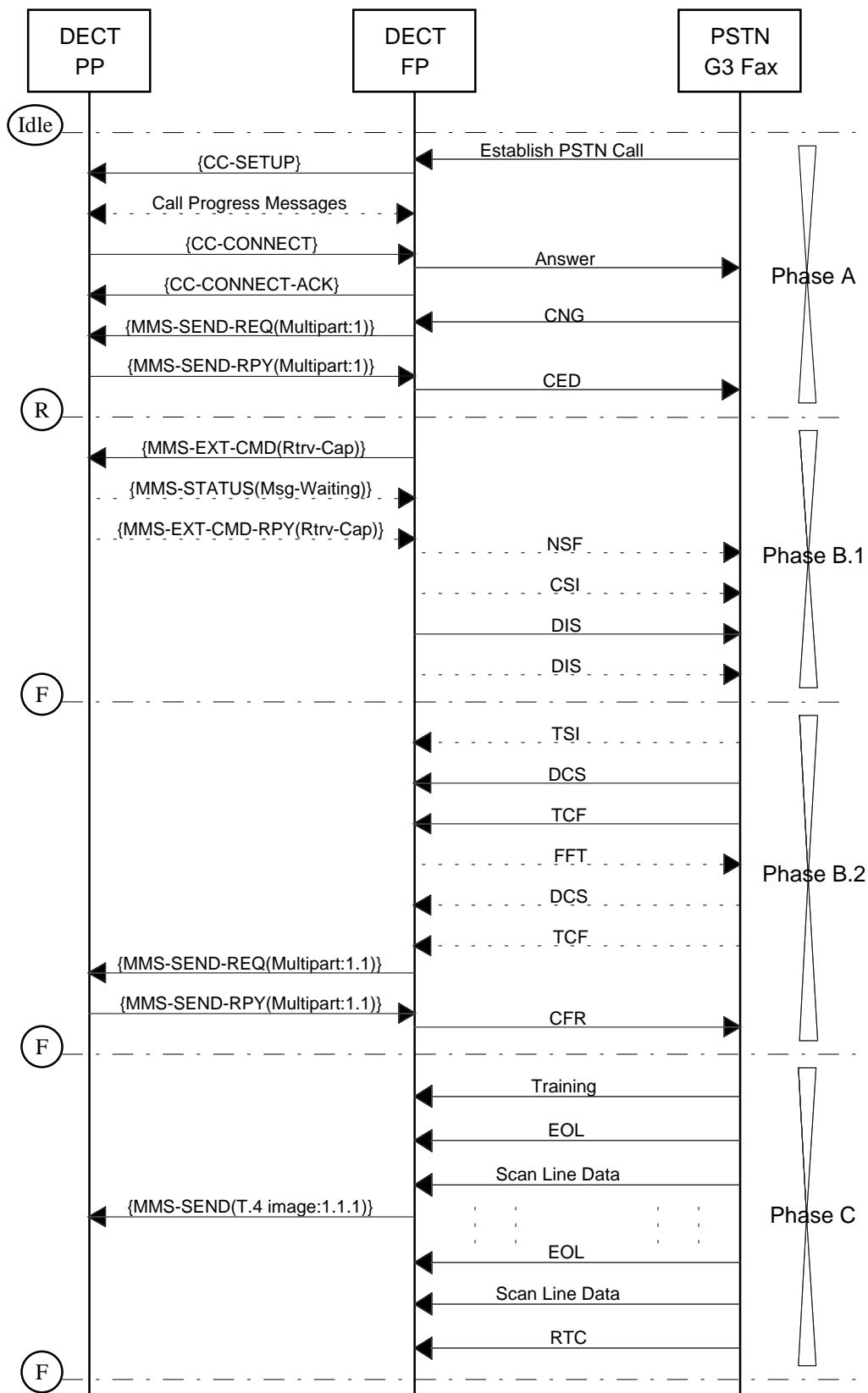

Figure C.13: Example message flows from phase A through to phase C

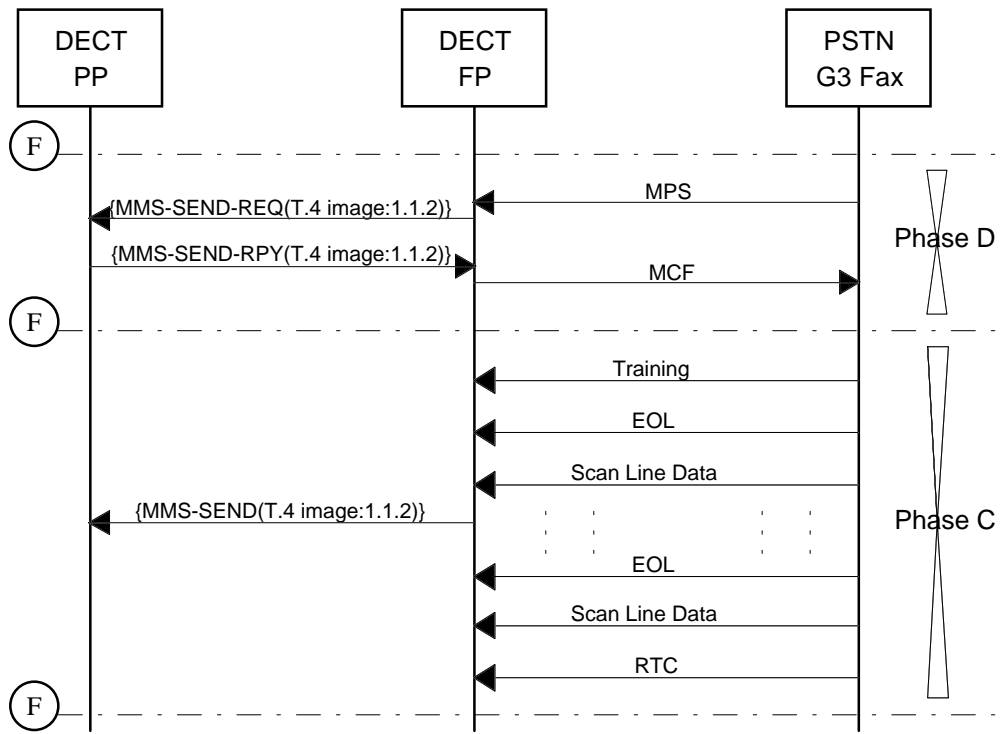

Figure C.14: Example message flows from phase D back to phase C

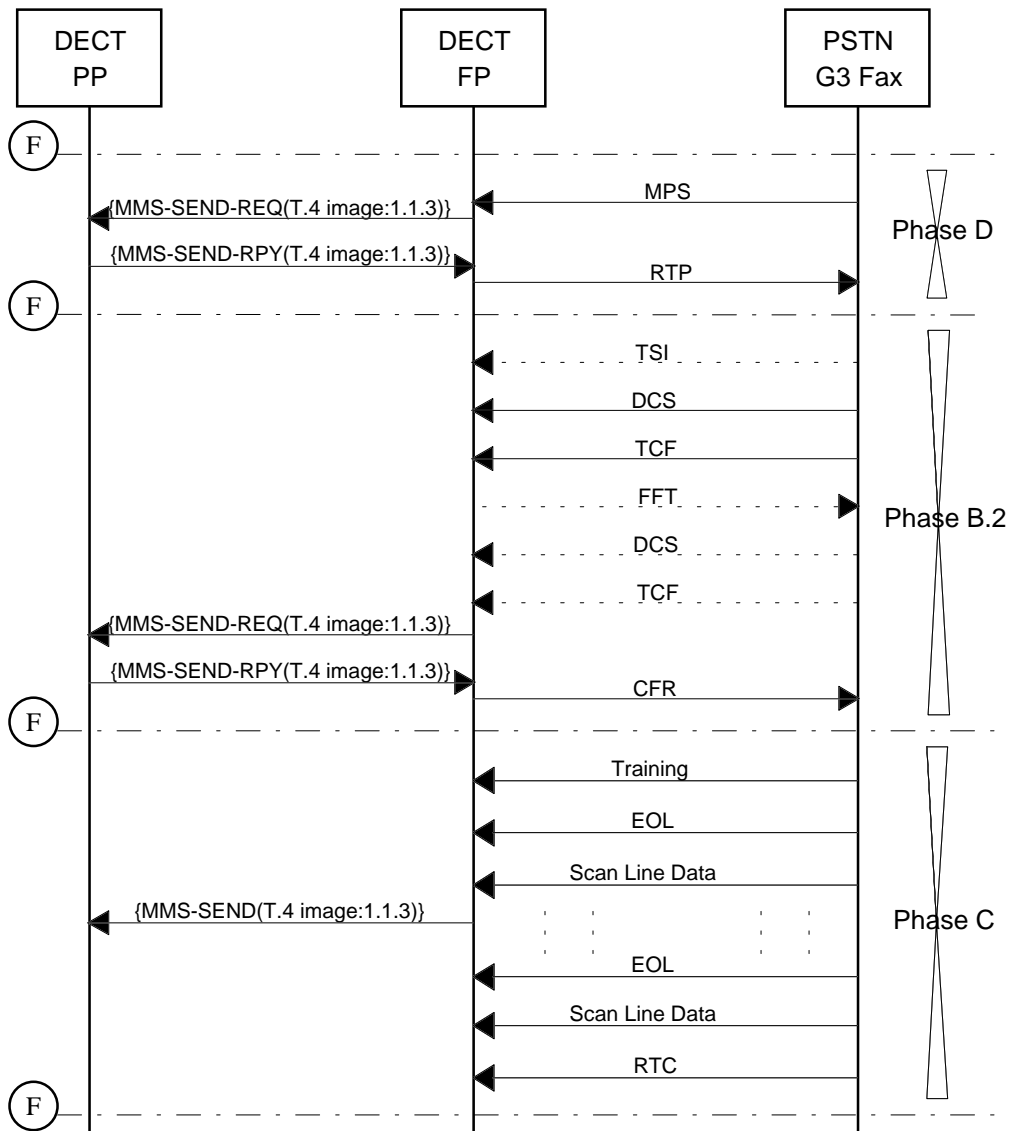

Figure C.15: Example message flows from phase D to phase B (re-training) and back to phase C

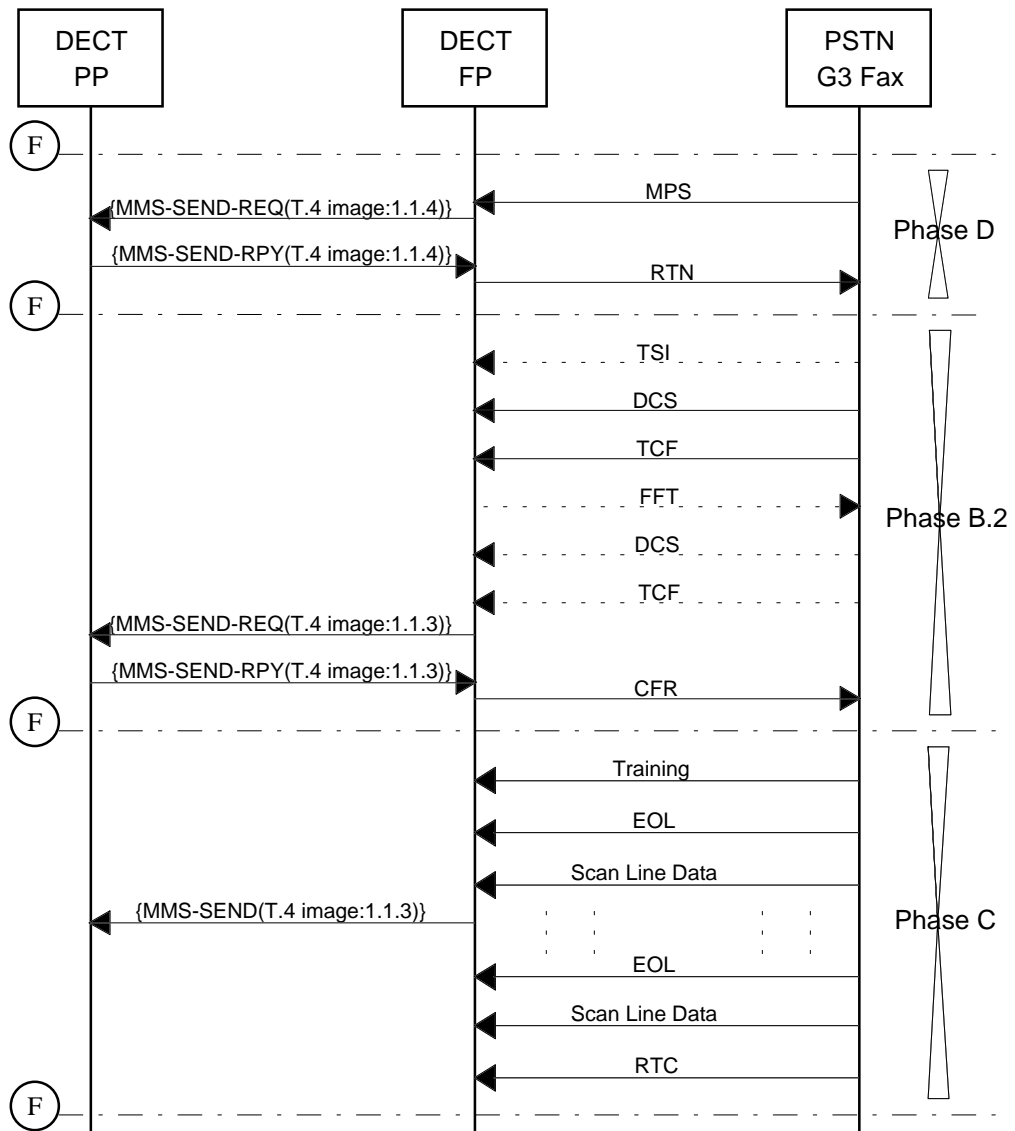

Figure C.16: Example message flows from phase D to phase B (re-transmission) and back to phase C

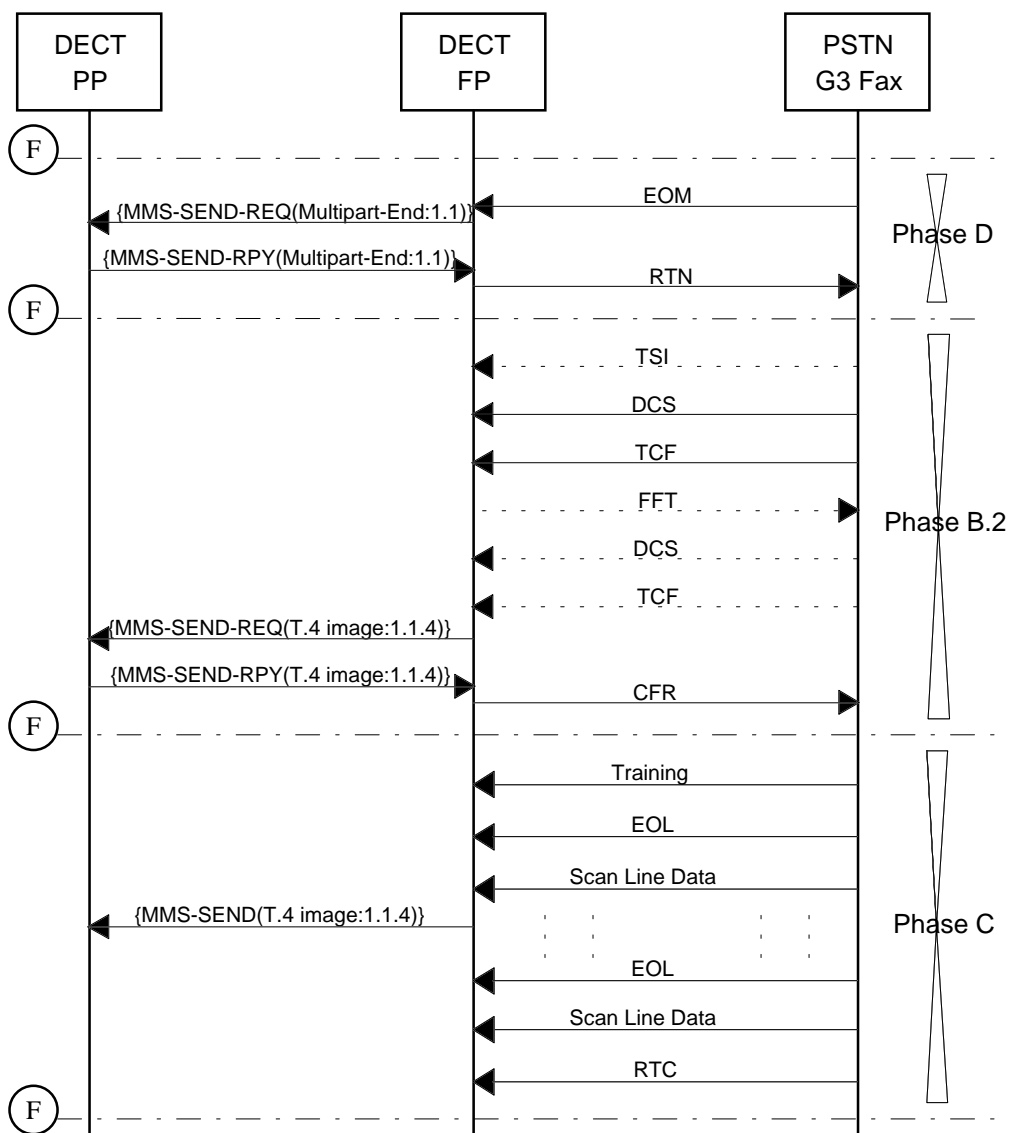

Figure C.17: Example message flows from phase D to phase B (different fax message) and back to phase C for re-transmission of previous page

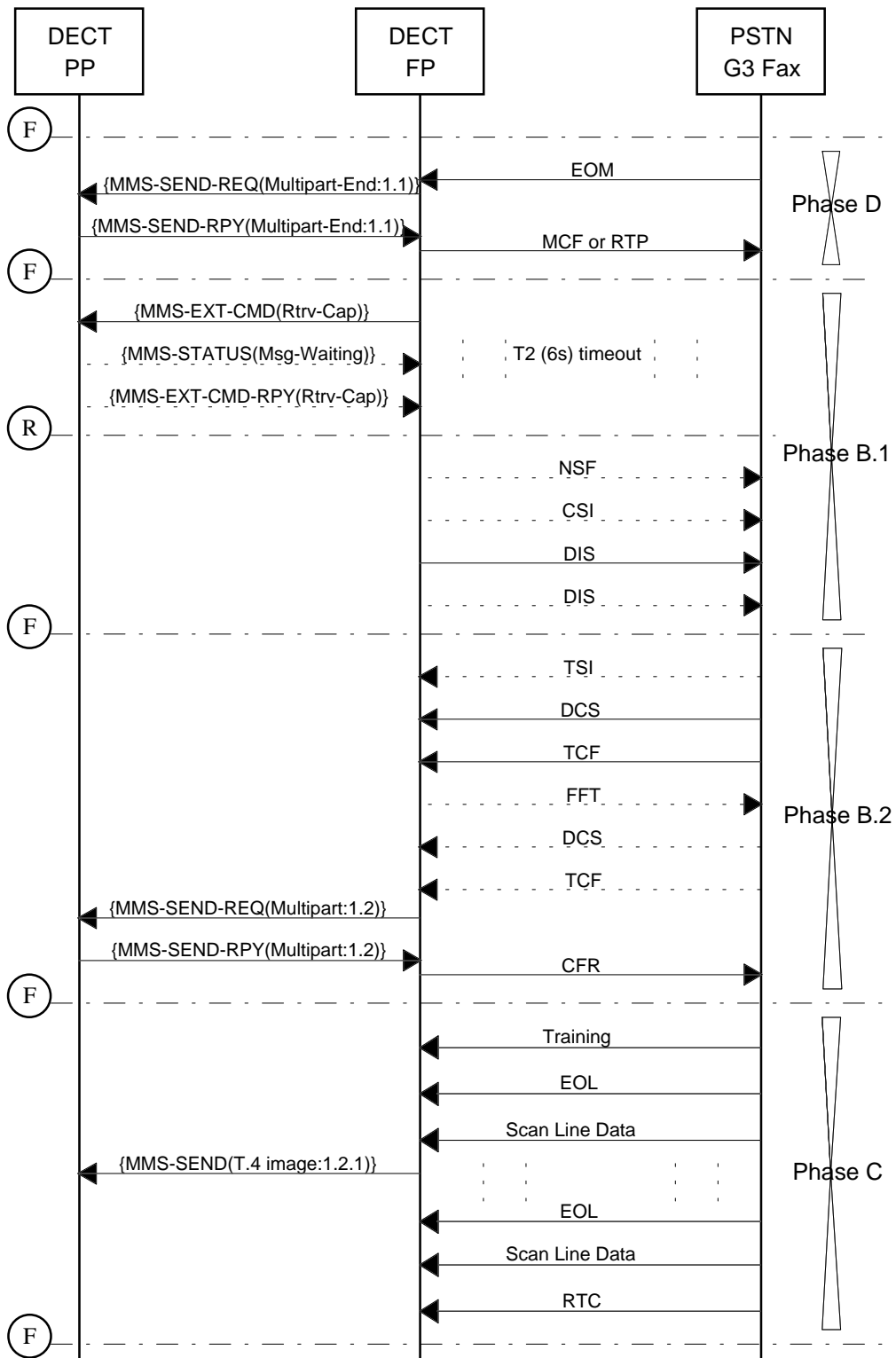

Figure C.18: Example message flows from phase D to phase B (different fax message) and back to phase C

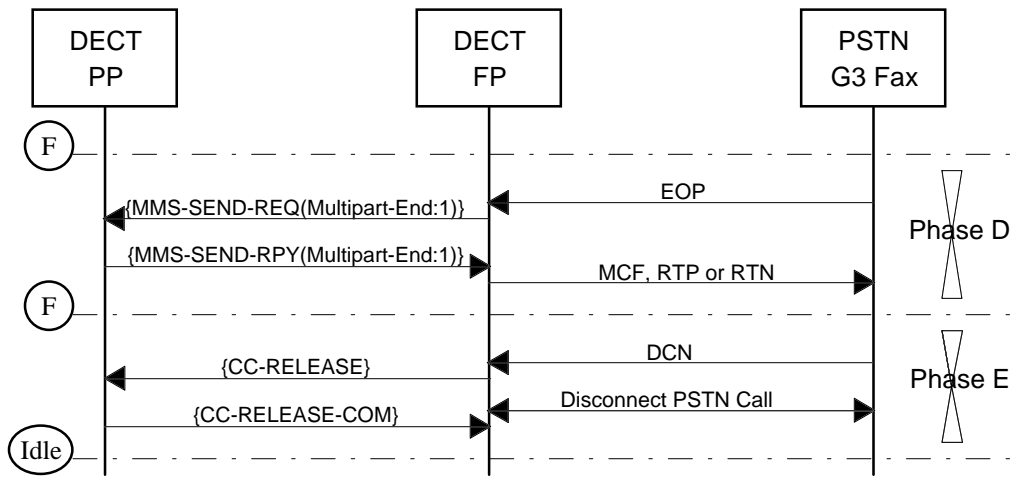

Figure C.19: Example message flows from phase D to phase E (no re-transmission carried out)

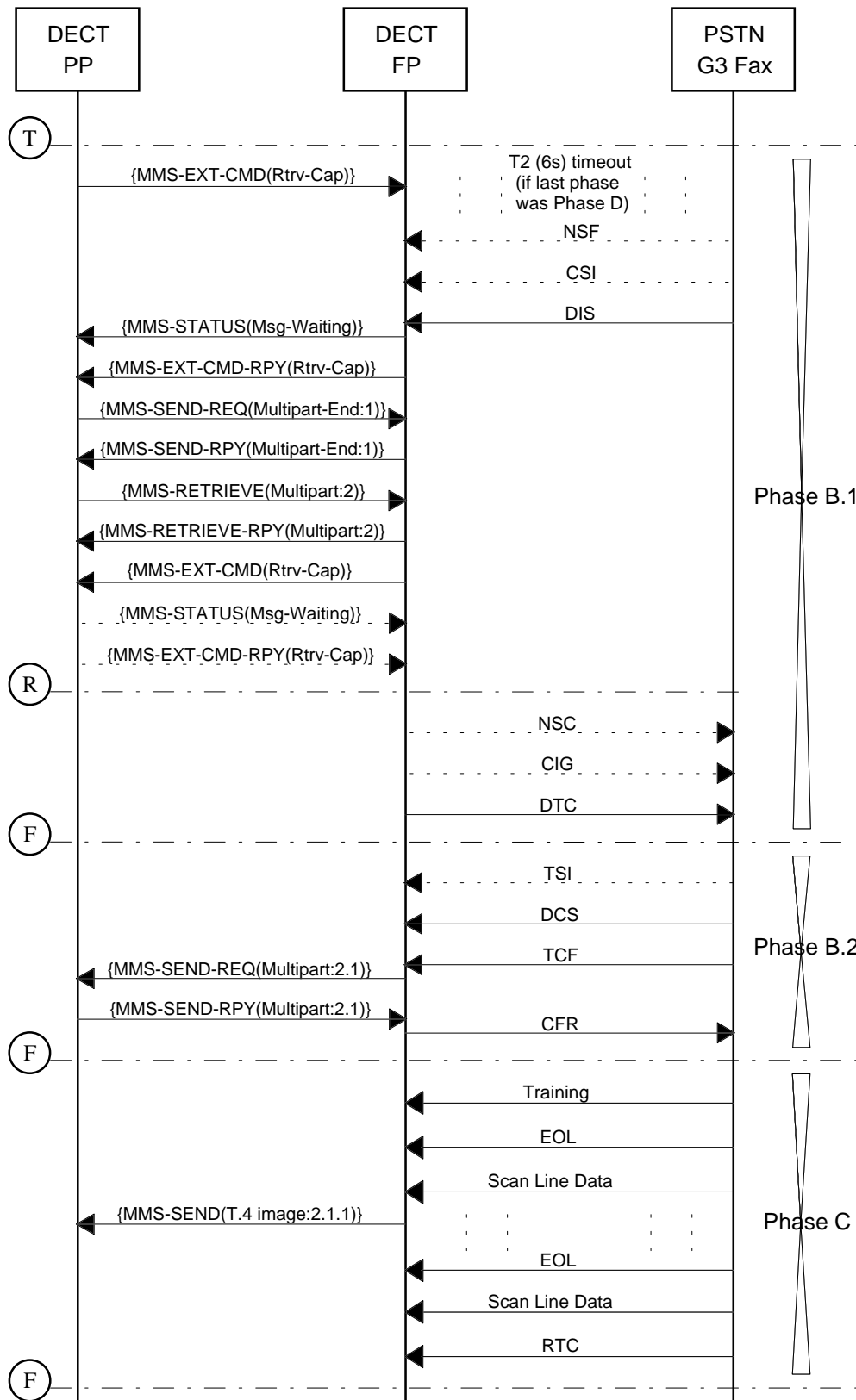

Figure C.20: Example message flows from phase B (outgoing fax message/call) to phase B and C (incoming fax message) (Option O.3 - Incoming Fax via fax polling)

Annex D (informative): Interworking conventions for store and forward facsimile group 3

It is expected and a major design goal of this interworking annex that PP designed to operate with the MMS real-time G3 Fax service (annex C) will also be able to interwork with FP designed for the store and forward G3 fax service (expected to be defined in a future edition of this ETS).

Annex E (informative): Interworking conventions for the GSM facsimile group 3 service

The interworking specification for the MMS (this profile) to the GSM facsimile service group 3 is defined in ETS 300 792 [24].

Annex F (normative): Service type C, class 2: Fixed termination NWK PICS proforma for E and F profile

For the purpose of this ETS only, the following PICS tables shall be used instead of the same tables of the service type C, class 2 data profile NWK PICS (ETS 300 651 [13]).

Notwithstanding the provisions of the copyright clause related to the text of the present ETS (see front page), ETSI grants users of this ETS to freely reproduce the PICS Proforma in this annex so that it can be used for its intended purposes and may further publish the completed PICS.

F.1 Standardized symbols for the status column

The standardized symbols for the status column are as follows:

- m or M for mandatory (the capability is required to be implemented);
- o or O for optional (Boolean) (the capability may be implemented);
- x or X for prohibited or excluded use (the capability may not be used in a given context);
- n/a, N/A or - (dash) for not applicable (the capability is not allowed because the underlying DECT layers (service provider) cannot handle it or the requirement belongs to an application i.e. does not belong to the network layer);
- c or C for conditional (the capability depends on the selection of other optional or/and conditional items);
- i or I for out of scope (the capability is allowed to be implemented but is not called upon by the profile functionality).

If appropriate, a "C" followed by an integer is placed in the status column, providing a reference to a conditional status expression defined elsewhere in the PICS proforma. The following conditions are applicable throughout the entire document:

C1m: IF LRMS (E profile) PTP supported then C1m=M ELSE I;
C1o: IF LRMS (E profile) PTP supported then C1o=O ELSE I;
C2m: IF LRMS (E profile) PTM supported then C2m=M ELSE I;
C2o: IF LRMS (E profile) PTM supported then C2o=O ELSE I;
C3m: IF MMS (F profile) supported then C3m=M ELSE I;
C3o: IF MMS (F profile) supported then C3o=O ELSE I.

In addition, tables, derived from the C.2 data profile NWK PICS may also contain references to conditional status expressions defined in the C.2 data profile NWK PICS. Where these may cause confusion with the conditions listed above, an asterisk has been appended to indicate that the definition in the C.2 profile NWK PICS shall be used.

F.2 Capabilities

F.2.1 Major capabilities

F.2.1.1 Services

The supplier of the implementation shall state the support of the implementation for each of the following services, in the table below.

Table F.1: Replacement of table Q.9.1 of ETS 300 651 [13] PICS: Services supported

Services supported				
Item no.	Name of service	Ref.	Protocol Status	Profile Support
1	Call control (CC)	5.2	O	M
2	Call independent supplementary services (CISS)	5.3	O	I
3	Connection oriented message services (COMS)	5.4	O	I
4	Connectionless message services (CLMS)	5.5	O	C2m
5	Mobility management (MM)	5.6	O	M
6	Link control entity (LCE)	5.7	O	M
7	Management	15	O	M
8	Error handling	17	O	M

Table F.2: Replacement of table Q.9.5 of ETS 300 651 [13] PICS: CLMS procedure support

Procedures supported				
Item no.	Name of procedure	Ref.	Protocol Status	Profile Support
1	clms_fixed	12.3.1	O	I
2	clms_variable	12.3.2	O	C2m

F.2.2.1 Timer support

The supplier of the implementation shall provide information about the timers specified in the ETS 300 175-5 [5].

Table F.3: Replacement of table Q.10.1 of ETS 300 651 [13] PICS: Timer support

Item no.	Name	Ref.	Timer supported		Values	
			Protocol Status	Profile Support	Allowed	Supported
1	CC.01	A.1	O	C1m	20 seconds	
2	CC.02	A.1	O	M	30 seconds	
3	CC.03	A.1	O	M	20 seconds	
4	CC.04	A.1	O	I	100 seconds	
5	CC.05	A.1				
6	COMS.00	A.3	Ccoms	I	5 seconds	
7	COMS.01	A.3	Ccoms	I	2 seconds	
8	COMS.02	A.3	Ccoms	I	10 seconds	
9	COMS.03	A.3	Ccoms	I	10 seconds	
10	CLMS.00	A.4	Cclms	C2m	5 seconds	
11	MM_access.1	A.5	X		60 seconds	
12	MM_access.2	A.5	O	M	20 seconds	
13	MM_auth.1	A.5	O	M	10 seconds	
14	MM_auth.2	A.5	O	M	100 seconds	
15	MM_cipher.1	A.5	O	C10*		
16	MM_cipher.2	A.5	O	M	10 seconds	
17	MM_ident.1	A.5	X			
18	MM_ident.2	A.5	O	O		
19	MM_key.1	A.5	O	O		
20	MM_locate.1	A.5	X		20 seconds	
21	MM_wait	A.5	O	I	5 minutes	
22	LCE.01	A.6	O	M	5 seconds	
23	LCE.02	A.6	Clce8	M	10 seconds	
24	LCE.03	A.6	O	M	3 seconds	
25	LCE.04	A.6	Clce5ORl ce6	I	5 seconds	
26	T601	part 6: B	O		5 minutes	
27	T602	part 6: B	O	M	5 minutes	

Table F.4: Replacement of table Q.11 of ETS 300 651 [13] PICS: CC message support

Supported messages						
Item no.	Name	Ref.	Sending (F to P)		Receipt (P to F)	
			Status	Support	Status	Support
14	IWU-INFORmation	6.3.2.14	O	C1m C3m	O	C1m C3m

Table F.5: Replacement of table Q.11.1 of ETS 300 651 [13] PICS: CC-SETUP

Item no.	Name of information element	Ref.	Sending (F to P)				Receipt (P to F)			
			Status	Supp.	Value		Status	Supp.	Value	
					Allowed	Supported			Allowed	Supported
1	Protocol Discriminator (PD)	7.2	M		3		M		3	
2	Transaction Identifier (TI)	7.3	M		0-6,ext		M		0-6,ext	
3	Message Type (MI)	7.4.1	M		5		M		5	
4	Portable identity	7.7.30	M		<Q.58>		M		<Q.58>	
5	Fixed identity	7.7.18	M		<Q.46>		M		<Q.46>	
6	Basic service	7.6.4	M		<Q.22>		M		<Q.22>	
6a	Repeat indicator	7.6.3	O	C5o*	<Q.21.2>		O	C5o*	<Q.21.2>	
7	IWU attributes	7.7.21	O	C1o C3m	<Q.49>		O	C1o C3m	<Q.49>	
8	Repeat indicator	7.6.3	O	C5o*	<Q.21.2>		O	C5o*	<Q.21.2>	
9	Call attributes	7.7.5	O		<Q.33>		O		<Q.33>	
10	Repeat indicator	7.6.3	O	I	<Q21.1>		O	I	<Q21.1>	
11	Connection attributes	7.7.11	O	C1o C3m	<Q.39>		O	C1o C3m	<Q.39>	
12	Cipher info	7.7.10	O	I	<Q.38>		O	I	<Q.38>	
13	Connection identity	7.7.12	O	I	<Q.40>		O	I	<Q.40>	
14	Facility	7.7.15	O	I	<Q.43>		O	I	<Q.43>	
15	Progress Indicator	7.7.31	O		<Q.59>		X			
16	Display	7.5.5	O	I	<Q.23 or <Q.54>		X			
17	Keypad	7.5.5	X				O		<Q24> or <Q55>	
18	Signal	7.6.8	O		<Q.26>		X			
19	Feature Activate	7.7.16	X		<Q.44>		O	C8*	<Q.44>	
20	Feature Indicate	7.7.17	O	C8*	<Q.45>		X			
21	Network parameter	7.7.29	X				O		<Q.57>	
22	Terminal capability	7.7.41	X				O	I	<Q.69>	
23	End-to-end compatibility	7.7.14	O	I	<Q.42>		O	I	<Q.42>	
24	Rate parameters	7.7.33	O	I	<Q.61>		O	I	<Q.61>	

(continued)

Table F.5 (concluded): Replacement of table Q.11.1 of ETS 300 651 [13] PICS: CC-SETUP

Item no.	Name of information element	Ref.	Sending (F to P)				Receipt (P to F)			
			Status	Supp.	Value		Status	Supp.	Value	
					Allowed	Supported			Allowed	Supported
25	Transit delay	7.7.42	O	I	<Q.70>		O	I	<Q.70>	
26	Window size	7.7.43	O	C1o C3m	<Q.71>		O	C1o C3m	<Q.71>	
27	Calling party number	7.7.9	O	I	<Q.37>		O	I	<Q.37>	
28	Called party number	7.7.7	O	I	<Q.35>		O	O	<Q.35>	
29	Called party subaddress	7.7.8	O	I	<Q.36>		O	I	<Q.36>	
30	Sending complete	7.6.2	O	I	<Q.20.1>		O	I	<Q.20.1>	
31	IWU-to-IWU	7.7.23	O	I	<Q.51>		O	I	<Q.51>	
32	IWU-PACKET	7.7.22	O	I	<Q.50>		O	I	<Q.50>	

Table F.6: Replacement of table Q.11.14 of ETS 300 651 [13] PICS: IWU-INFORMATION

Item no.	Name of information element	Ref.	Sending (F to P)				Receipt (P to F)			
			Protocol Status	Profile Supp.	Value		Protocol Status	Profile Supp.	Value	
					Allowed	Supported			Allowed	Supported
1	Protocol Discriminator (PD)	7.2	M		3		M		3	
2	Transaction Identifier (TI)	7.3	M		0-6,8-14,ext		M		0-6,8-14,ext	
3	Message Type (MI)	7.4.1	M		96		M		96	
4	MMS Generic Header		O	C1m C3m			O	C1m C3m		
5	MMS Object Header		O	C1m C3m			O	C1m C3m		
6	MMS Extended Header		O	C1o C3o			O	C1o C3o		
7	Time/Date		O	C1m C3m			O	C1m C3m		
8	Calling Party Number		O	C1m C3m			O	C1m C3m		
9	Called Party Number		O	C1m C3m			O	C1m C3m		
10	Called Party Subaddress		O	C1m C3m			O	C1m C3m		
11	Repeat Indicator		O	C1o C3o			O	C1o C3o		
12	Segmented Info	7.7.37	O	C1m C3m	<Q.65>		O	C1m C3m	<Q.65>	
13	Alphanumeric	7.7.3	O	I	<Q.31>		O	I	<Q.31>	
14	IWU-to-IWU	7.7.23	O	C1o	<Q.51>		O	C1o	<Q.51>	
15	IWU-packet	7.7.22	O	I	<Q.50>		O	I	<Q.50>	

Table F.7: Replacement of table Q.14 of ETS 300 651 [13] PICS: CLMS message support

Supported messages						
Item no.	Name	Ref.	Sending (F to P)		Receipt (P to F)	
			Status	Support	Status	Support
1	CLMS-VARIABLE	6.3.5.1	Cclms	C2m	Cclms	I
2	CLMS-FIXED-long-B-format	8.3.1-2	Cclms	I	-	
3	CLMS-FIXED-extended-B-format	8.3.1-2	Cclms	I	-	

Table F.8: Replacement of table Q.14.1 of ETS 300 651 [13] PICS: CLMS-VARIABLE

Item no.	Name of information element	Ref.	Sending (F to P)				Receipt (P to F)			
			Protocol Status	Profile Supp.	Value		Protocol Status	Profile Supp.	Value	
					Allowed	Supported			Allowed	Supported
1	Protocol Discriminator (PD)	7.2	M		6		M		6	
2	Transaction Identifier (TI)	7.3	M		0		M		0	
3	Message Type (MI)	7.4.1	M		1		M		1	
4	Portable Identity	7.7.30	M		<Q.58.9-12>		M		<Q.58.1-8>	
5	MMS Generic Header	7.7.47	O	C2m			O	I		
6	MMS Object Header	7.7.48	O	C2m			O	I		
7	MMS Extended Header	7.7.49	O	C2o			O	I		
8	Time/Date	7.7.50	O	C2m			O	I		
9	Calling Party Number	7.7.9	O	C2m			O	I		
10	Called Party Number	7.7.7	O	C2m			O	I		
11	Called Party Subaddress	7.7.8	O	C2m			O	I		
12	Repeat Indicator	7.6.3	O	C2o			O	I		
13	Segmented Info	7.7.37	O	C2m	<Q.65>		O	I	<Q.65>	
14	Alphanumeric	7.7.3	O		<Q.31>		O	I	<Q.31>	
15	IWU-to-IWU	7.7.23	O	C2m	<Q.51>		O	I	<Q.51>	
16	IWU-packet	7.7.22	O	I	<Q.50>		O	I	<Q.50>	

Table F.9: Replacement of table Q.17 of ETS 300 651 [13] PICS: Information element support

Supported information elements						
Item no.	Name	Ref.	Sending (F to P)		Receipt (P to F)	
			Status	Support	Status	Support
3	Repeat indicator (non prioritized)	7.6.3	O	C1o C2o C3o	O	C1o C3o
17	Called party number	7.7.7	O	C1m C2m C3m	O	C1m C3m
18	Called party subaddress	7.7.8	O	C1m C2m C3m	O	C1m C3m
19	Calling party number	7.7.9	O	C1m C2m C3m	O	C1m C3m
21	Connection attributes	7.7.11	O	C1o C3m	O	C1o C3m
31	IWU attributes	7.7.21	O	C1o C3m	O	C1o C3m
33	IWU to IWU	7.7.23	O	C1m C2m	O	C1m
55	MMS-Generic-Header	7.7.47	O	C1m C2m C3m	O	C1m C3m
56	MMS-Object-Header	7.7.48	O	C1m C2m C3m	O	C1m C3m
57	MMS-Extended-Header	7.7.49	O	C1o C2o C3o	O	C1o C3o
58	Time-Date	7.7.50	O	C1m C2m C3m	O	C1m C3m

Table F.10: Replacement of table Q.22 of ETS 300 651 [13] PICS: Basic service implemented

Supported parameters						
Field no.	Name of fields	Ref.	Protocol Status	Supp	Values	
					Allowed	Supported
1	Identifier for double octet	7.6.1	M		6	
2	2nd-ID of basic service of fixed length	7.6.1	M		0	
3	Call class	7.6.4	M		4,8,9,10,11,12,13	4,8
4	Basic service	7.6.4	M		0, 4, 5,6,15	C1o = 5 15

Table F.11: Replacement of table Q.35 of ETS 300 651 [13] PICS: Called party number implemented

Supported parameters						
Field no.	Name of fields	Ref.	Protocol Status	Supp	Values	
					Allowed	Supported
1	ID of called party number	7.7.1	M		112	
2	Length of Contents (L)	7.7.7	M		2-255	
3	Number type	7.7.7	M		0-4,6	
4	Numbering plan identification	7.7.7	M		0,1,3,7-9, 11-14	
5	Called party address(the first DECT character)	7.7.7	M		00,02,03,05-0F,11-14,16,19-1B,20-7F (HEX)	
6	Called party address(list of the rest DECT character)	7.7.7	M		00,02,03,05-0F,11-14,16,19-1B,20-7F (HEX)	

Table F.12: Replacement of table Q.37 of ETS 300 651 [13] PICS: Calling party number implemented

Supported parameters						
Field no.	Name of fields	Ref.	Protocol Status	Supp	Values	
					Allowed	Supported
1	ID of called party number	7.7.1	M		108	
2	Length of Contents (L)	7.7.9	M		2-255	
3	Number type	7.7.9	M		0-4,6	
4	Numbering plan identification	7.7.9	M		0,1,3,7-9, 11-14	
5	Called party address(the first DECT character)	7.7.9	M		00,02,03,05-0F,11-14,16,19-1B,20-7F (HEX)	
6	Called party address(list of the rest DECT character)	7.7.9	M		00,02,03,05-0F,11-14,16,19-1B,20-7F (HEX)	

Table F.13: Replacement of table Q.39 of ETS 300 651 [13] PICS: Connection attributes implemented

Supported parameters						
Field no.	Name of fields	Ref.	Protocol Status	Supp	Values	
					Allowed	Supported
1	ID of connection attributes	7.7.1	M		23	
2	Length of Contents (L)	7.7.11	M		4-9	
3	Symmetry	7.7.11	M		1,4-7	
4	Connection identity	7.7.11	M		0,8-15	8-15
5	Target bearers (P => F direction)	7.7.11	M		0,1-31	C1m = 0 1-23
6	Minimum bearers (P => F direction)	7.7.11	O	O	0,1-31	C1m = 0 1-23
7	Target bearers (F => P direction)	7.7.11	O	C2	0,1-31	C1m = 0 1-23
8	Minimum bearers (F => P direction)	7.7.11	O	C2	0,1-31	C1m = 0 1-23
9	MAC slot size	7.7.11	M		0,4,5	4
10	MAC service (P => F direction)	7.7.11	M		0-3	3
11	MAC service (F => P direction)	7.7.11	O	C2	0-3	3
12	CF channel attributes (P => F direction)	7.7.11	M		0,2-5	2
13	MAC packet life time (P =>F direction)	7.7.11	M		0,8-15	8-15
14	CF channel attributes (F => P direction)	7.7.11	O	C2	0,2-5	2
15	MAC packet life time (F =>P direction)	7.7.11	O	C2	0,8-15	8-15

Table F.14: Replacement of table Q.49 of ETS 300 651 [13] PICS: IWU attributes implemented

Supported parameters						
Field no.	Name of fields	Ref.	Protocol Status	Supp	Values	
					Allowed	Supported
1	ID of IWU attributes of variable length	7.7.1	M		18	
2	Length of Contents (L)	7.7.21	M		4-	
3	Coding standard	7.7.21	M		0,1	
4	Profile	7.7.21	M		0,1,2,3,4,8,9, 10,11,12	C1m = 3 C3m = 4
5	Negotiation indicator	7.7.21	M		0,2,4,6	
6	Profile subtype	7.7.21	M		Note 1	
7	IWU attributes information	7.7.21	O		Note 1	

NOTE 1: The codings of the interworking service dependent fields shall be given in the interworking annexes.

Table F.15: Replacement of table Q.51 of ETS 300 651 [13] PICS: IWU-TO-IWU

Supported parameters						
Field no.	Name of fields	Ref.	Protocol Status	Supp	Values	
					Allowed	Supported
1	ID of IWU attributes of variable length	7.7.1	M		18	
2	Length of Contents (L)	7.7.23	M		4-	
3	Send/Reject	7.7.23	M		0,1	
4	Protocol Discriminator	7.7.23	M		0-2, 4,8-10, 16,17, 20, 63	20
5	Iwu-to-iwu information	7.7.23	M		0 -	

Table F.16: Replacement of table Q.80 of ETS 300 651 [13] PICS: Error & exception handling procedure support

Item no.	Name of procedure	Ref.	Protocol Status	Profile Support
1	eeh_protocol_discriminator_error	17.1	M	
2	eeh_message_too_short	17.2	M	
3	eeh_unsupported_transaction_identity_error	17.3.1	M	
4	eeh_unknown_active_cc_call	17.3.2.1	M	
5	eeh_unknown_active_ciss_call	17.3.2.2	Cciss	I
6	eeh_unknown_active_coms_call	17.3.2.3	Ccoms	I
7	eeh_unknown_active_clms_call	17.3.2.4	Cclms	C2m
8	eeh_unknown_active_mm_transaction	17.3.2.5	M	
9	eeh_cc_message_error	17.4.1	M	
10	eeh_ciss_message_error	17.4.2	Cciss	I
11	eeh_coms_&_clms_message_error	17.4.3	CcomsORclms	C2m
12	eeh_mm_message_error	17.4.4	M	
13	eeh_info_element_out_of_sequence	17.5.1	M	
14	eeh_duplicated_info_elements	17.5.2	M	
15	eeh_mandatory_info_element_missing_in_cc_message	17.6.1	M	
16	eeh_mandatory_info_element_content_error_in_cc_message	17.6.2	M	
17	eeh_mandatory_info_element_missing_in_coms_&_clms_message	17.6.3	CcomsORclms	I
18	eeh_mandatory_info_element_missing_in_mm_message	17.6.4	M	
19	eeh_unrecognised_info_element	17.7.1	M	
20	eeh_non-mandatory_info_element_content_error	17.7.2	M	
21	eeh_data_link_reset	17.8	M	
22	eeh_data_link_failure	17.9	M	

Table F.17: Replacement of table Q.100 of ETS 300 651 [13] PICS: MMS-Generic-Header

Supported parameters						
Field no.	Name of fields	Ref.	Protocol Status	Supp	Values	
					Allowed	Supported
1	ID of MMS-Generic-Header of variable length	7.7.1	M		32	
2	Length of Contents (L)	7.7.47	M		4-	
3	MMS Command type	7.7.47	M		0-13	
4	Reply Requested	7.7.47	M		0-3	
5	Extended MMS command type	7.7.47	O		0, 8, 9, 56-58, 64-66, 72-76	
5	MMS message Identifier	7.7.47	M		0-127	
6	MMS extended message identifier	7.7.47	O		0-127	
7	Service Type	7.7.47	O		0-4,8-13,16-20,22, 23,32-39, 96-127	
8	Service subtype	7.7.47	O		0 -	
9	Command outcome	7.7.47	O		0, 1, 4-6, 8-11, 32-40, 48, 64-66, 68-70, 72, 73, 76, 77, 80 - 83	
10	Command outcome - IE support	7.7.47	O		0-127	
11	Command outcome - IE support	7.7.47	O		0-127	

Table F.18: Replacement of table Q.101 of ETS 300 651 [13] PICS: MMS-Object-Header

Supported parameters						
Field no.	Name of fields	Ref.	Protocol Status	Supp	Values	
					Allowed	Supported
1	ID of MMS-Object-Header of variable length	7.7.1	M		33	
2	Length of Contents (L)	7.7.48	M		4-	
3	Length Description	7.7.48	M		0-2	
4	Number of length octets	7.7.48	M		0-7	
5	User data length octets	7.7.48	O			
6	Source user data category	7.7.48	M		0-3	
7	Source user data transfer encoding	7.7.48	M		0,1,2,4,5,8	
8	Destination user data category	7.7.48	O		0-3	
9	Destination user data transfer encoding	7.7.48	O		0,1,2,4,5,8	
10	Source user data type	7.7.48	M		0, 1, 2, 4, 5, 6, 8- 14, 16 - 20, 32 - 40, 56, 57, 63 - 66,69,70, 72 - 76, 120, 127	
11	Extended Source user data type	7.7.48	O		0 - 6, 9 - 12, 16 - 20, 25 - 28, 33 - 36	
12	Destination user data type	7.7.48	O		0, 1, 2, 4, 5, 6, 8- 14, 16 - 20, 32 - 40, 56, 57, 63 - 66,69,70, 72 - 76, 120, 127	
13	Extended destination user data type	7.7.48	O		0-6, 9-12, 16-20, 25-28, 33-36	
14	Multipart parent message identifier	7.7.48	O		0-127	
15	Multipart parent message extended identifier	7.7.48	O		0-127	

Table F.19: Replacement of table Q.102 of ETS 300 651 [13] PICS: MMS-Ext-Header

Supported parameters						
Field no.	Name of fields	Ref.	Protocol Status	Supp	Values	
					Allowed	Supported
1	ID of MMS-Ext-Header of variable length	7.7.1	M		34	
2	Length of Contents (L)	7.7.49	M		4-	
3	Attribute Category	7.7.49	M		0-4	
4	Attribute Identifier	7.7.49	M		0-4	
5	Extended attribute identifier	7.7.49	O		0 -127	
6	Message Attributes	7.7.49	M		0 -	

Table F.20: Replacement of table Q.103 of ETS 300 651 [13] PICS: Time-Date

Supported parameters						
Field no.	Name of fields	Ref.	Protocol Status	Supp	Values	
					Allowed	Supported
1	ID of Time-Date of variable length	7.7.1	M		35	
2	Length of Contents (L)	7.7.50	M		4-	
3	Coding	7.7.50	M		1,2,3	
4	Interpretation	7.7.50	M		0,1,32 - 36, 40	
5	Time and date information	7.7.50	M		0 -	

Annex G (normative): Service type C, class 2: Portable termination NWK PICS proforma for E and F profiles

For the purpose of this ETS only, the following PICS tables shall be used instead of the same tables of the C.2 data profile NWK PICS. For those features, messages, information elements and field codings not listed here the codings of the C.2 profile PICS shall apply.

Notwithstanding the provisions of the copyright clause related to the text of the present ETS (see front page), ETSI grants users of this ETS to freely reproduce the PICS Proforma in this annex so that it can be used for its intended purposes and may further publish the completed PICS.

G.1 Standardized symbols for the status column

The standardized symbols for the status column are as follows:

- m or M for mandatory (the capability is required to be implemented);
- o or O for optional (Boolean) (the capability may be implemented);
- x or X for prohibited or excluded use (the capability may not be used in a given context);
- n/a, N/A or - (dash) for not applicable (the capability is not allowed because the underlying DECT layers (service provider) cannot handle it or the requirement belongs to an application i.e. does not belong to the network layer);
- c or C for conditional (the capability depends on the selection of other optional or/and conditional items);
- i or I for out of scope (the capability is allowed to be implemented but is not called upon by the profile functionality).

If appropriate, a "C" followed by an integer is placed in the status column, providing a reference to a conditional status expression defined elsewhere in the PICS proforma. The following conditions are applicable throughout this annex:

C1m: IF LRMS (E profile) PTP supported then C1m=M ELSE I;
C1o: IF LRMS (E profile) PTP supported then C1o=O ELSE I;
C2m: IF LRMS (E profile) PTM supported then C2m=M ELSE I;
C2o: IF LRMS (E profile) PTM supported then C2o=O ELSE I;
C3m: IF MMS (F profile) supported then C3m=M ELSE I;
C3o: IF MMS (F profile) supported then C3o=O ELSE I.

In addition, tables, derived from the C.2 data profile NWK PICS may also contain references to conditional status expressions defined in the C.2 data profile NWK PICS. Where these may cause confusion with the conditions listed above, an asterisk has been appended to indicate that the definition in the C.2 profile NWK PICS shall be used.

G.2 Capabilities

G.2.1 Major capabilities

G.2.1.1 Services

The supplier of the implementation shall state the support of the implementation for each of the following services, in the table below.

Table G.1: Replacement of table Q.9.1 of ETS 300 651 [13] PICS: Services supported

Services supported				
Item no.	Name of service	Ref.	Protocol Status	Profile Support
1	Call control (CC)	5.2	O	M
2	Call independent supplementary services (CISS)	5.3	O	I
3	Connection oriented message services (COMS)	5.4	O	I
4	Connectionless message services (CLMS)	5.5	O	C2m
5	Mobility management (MM)	5.6	O	M
6	Link control entity (LCE)	5.7	O	M
7	Management	15	O	M
8	Error handling	17	O	M

Table G.2: Replacement of table Q.9.5 of ETS 300 651 [13] PICS: CLMS procedure support

Procedures supported				
Item no.	Name of procedure	Ref.	Protocol Status	Profile Support
1	clms_fixed	12.3.1	O	I
2	clms_variable	12.3.2	O	C2m

Table G.3: Replacement of table Q.10.1 of ETS 300 651 [13] PICS: Timer support

Timer supported						
Item no.	Name	Ref.	Protocol Status	Profile Support	Values	
					Allowed	Supported
1	CC.01	A.1	O	C1m	20 seconds	
2	CC.02	A.1	O	M	30 seconds	
3	CC.03	A.1	O	M	20 seconds	
4	CC.04	A.1	O	I	100 second	
5	CC.05	A.1	X			
6	COMS.00	A.3	O	I	5 seconds	
7	COMS.01	A.3	O	I	2 seconds	
8	COMS.02	A.3	O	I	10 seconds	
9	COMS.03	A.3	O	I	10 seconds	
10	CLMS.00	A.4	O	C2m	5 seconds	
11	MM_access.1	A.5	O	M	60 seconds	
12	MM_access.2	A.5	O	X	20 seconds	
13	MM_auth.1	A.5	O	X	10 seconds	
14	MM_auth.2	A.5	O	X	100 seconds	
15	MM_cipher.1	A.5	X			
16	MM_cipher.2	A.5	O	C4*	10 seconds	
17	MM_ident.1	A.5	X			
18	MM_ident.2	A.5	X			
19	MM_key.1	A.5	X			
20	MM_locate.1	A.5	O	M	20 seconds	
21	MM_wait	A.5	O	I	5 minutes	
22	LCE.01	A.6	O	M	5 seconds	
23	LCE.02	A.6	O	M	10 seconds	
24	LCE.03	A.6	O	M	3 seconds	
25	LCE.04	A.6	O	I	5 seconds	
26	T601	part 6: B	O		5 minutes	
27	T602	part 6: B	O	M	5 minutes	

Table G.4: Replacement of table Q.11.1 of ETS 300 651 [13] PICS: CC-SETUP

Item no.	Name of information element	Ref.	Sending (F to P)				Receipt (P to F)			
			PROToc ol Status	Profile Supp.	Value		PROToc ol Status	Profile Supp.	Value	
					Allowed	Supported			Allowed	Supported
1	Protocol Discriminator (PD)	7.2	M		3		M		3	
2	Transaction Identifier (TI)	7.3	M		0-6,ext		M		0-6,ext	
3	Message Type (MI)	7.4.1	M		5		M		5	
4	Portable identity	7.7.30	M		<Q.58>		M		<Q.58>	
5	Fixed identity	7.7.18	M		<Q.46>		M		<Q.46>	
6	Basic service	7.6.4	M		<Q.22>		M		<Q.22>	
6a	Repeat indicator	7.6.3	O	C5o*	<Q.21.2>		O	C5o*	<Q.21.2>	
7	IWU attributes	7.7.21	O	C1o C3m	<Q.49>		O	C1o C3m	<Q.49>	
8	Repeat indicator	7.6.3	O	C5o*	<Q.21.2>		O	C5o*	<Q.21.2>	
9	Call attributes	7.7.5	O		<Q.33>		O		<Q.33>	
10	Repeat indicator	7.6.3	O	I	<Q21.1>		O	I	<Q21.1>	
11	Connection attributes	7.7.11	O	C1o C3m	<Q.39>		O	C1o C3m	<Q.39>	
12	Cipher info	7.7.10	O	I	<Q.38>		O	I	<Q.38>	
13	Connection identity	7.7.12	O	I	<Q.40>		O	I	<Q.40>	
14	Facility	7.7.15	O	I	<Q.43>		O	I	<Q.43>	
15	Progress Indicator	7.7.31	X				O		<Q.59>	
16	Display	7.5.5	X				O	I	<Q.23 or <Q.54>	
17	Keypad	7.5.5	O		<Q24> or <Q55>		X			
18	Signal	7.6.8	X				O	C1m*	<Q.26>	
19	Feature Activate	7.7.16	O	C8	<Q.44>		X		<Q.44>	
20	Feature Indicate	7.7.17	X				O	C8	<Q.45>	

(continued)

Table G.4 (concluded): Replacement of table Q.11.1 of ETS 300 651 [13] PICS: CC-SETUP

Item no.	Name of information element	Ref.	Sending (F to P)				Receipt (P to F)			
			PROToC ol Status	Profile Supp.	Value		PROToC ol Status	Profile Supp.	Value	
					Allowed	Supported			Allowed	Supported
21	Network parameter	7.7.29	O		<Q.57>		X			
22	Terminal capability	7.7.41	O	I	<Q.69>		X			
23	End-to-end compatibility	7.7.14	O	I	<Q.42>		O	I	<Q.42>	
24	Rate parameters	7.7.33	O	I	<Q.61>		O	I	<Q.61>	
25	Transit delay	7.7.42	O	I	<Q.70>		O	I	<Q.70>	
26	Window size	7.7.43	O	C1o C3m	<Q.71>		O	C1o C3m	<Q.71>	
27	Calling party number	7.7.9	O	I	<Q.37>		O	I	<Q.37>	
28	Called party number	7.7.7	O	O	<Q.35>		O	I	<Q.35>	
29	Called party subaddress	7.7.8	O	I	<Q.36>		O	I	<Q.36>	
30	Sending complete	7.6.2	O	I	<Q.20.1>		O	I	<Q.20.1>	
31	IWU-to-IWU	7.7.23	O	I	<Q.51>		O	I	<Q.51>	
32	IWU-PACKET	7.7.22	O	I	<Q.50>		O	I	<Q.50>	

Table G.5: Replacement of table Q.11.14 of ETS 300 651 [13] PICS: IWU-INFORMATION

Item no.	Name of information element	Ref.	Sending (F to P)				Receipt (P to F)			
			PROToC ol Status	Profile Supp.	Value		PROToC ol Status	Profile Supp.	Value	
					Allowed	Supported			Allowed	Supported
1	Protocol Discriminator (PD)	7.2	M		3		M		3	
2	Transaction Identifier (TI)	7.3	M		0-6,8-14,ext		M		0-6,8-14,ext	
3	Message Type (MI)	7.4.1	M		96		M		96	
4	MMS Generic Header	7.7.47	O	C1m C3m			O	C1m C3m		
5	MMS Object Header	7.7.48	O	C1m C3m			O	C1m C3m		
6	MMS Extended Header	7.7.49	O	C1o C3o			O	C1o C3o		
7	Time/Date	7.7.50	O	C1m C3m			O	C1m C3m		
8	Calling Party Number	7.7.9	O	C1m C3m			O	C1m C3m		
9	Called Party Number	7.7.8	O	C1m C3m			O	C1m C3m		
10	Called Party Subaddress	7.7.7	O	C1m C3m			O	C1m C3m		
11	Repeat Indicator	7.6.3	O	C1o C3o			O	C1o C3o		
12	Segmented Info	7.7.37	O	C1m C3m	<Q.65>		O	C1m C3m	<Q.65>	
13	Alphanumeric	7.7.3	O	I	<Q.31>		O		<Q.31>	
14	IWU-to-IWU	7.7.23	O	C1m	<Q.51>		O	C1m	<Q.51>	
15	IWU-packet	7.7.22	O	I	<Q.50>		O		<Q.50>	

Table G.6: Replacement of table Q.14 of ETS 300 651 [13] PICS: CLMS message support

Supported messages						
Item no.	Name	Ref.	Sending (P to F)		Receipt (F to P)	
			Status	Support	Status	Support
1	CLMS-VARIABLE	6.3.5.1	Cclms	I	Cclms	C2m
2	CLMS-FIXED-long-B-format	8.3.1-2	-		Cclms	I
3	CLMS-FIXED-extended-B-format	8.3.1-2	-		Cclms	I

Table G.7: Replacement of table Q.14.1 of ETS 300 651 [13] PICS: CLMS-VARIABLE

Item no.	Name of information element	Ref.	Sending (F to P)				Receipt (P to F)			
			PROToc ol Status	Profile Supp.	Value		Status	Profile Supp.	Value	
					Allowed	Supported			Allowed	Supported
1	Protocol Discriminator (PD)	7.2	M		6		M		6	
2	Transaction Identifier (TI)	7.3	M		0		M		0	
3	Message Type (MI)	7.4.1	M		1		M		1	
4	Portable Identity	7.7.30	M		<Q.58.9-12>		M		<Q.58.1-8>	
5	MMS Generic Header	7.7.47	O	I			O	C2m		
6	MMS Object Header	7.7.48	O	I			O	C2m		
7	MMS Extended Header	7.7.49	O	I			O	C2o		
8	Time/Date	7.7.50	O	I			O	C2m		
9	Calling Party Number	7.7.9	O	I			O	C2m		
10	Called Party Number	7.7.7	O	I			O	C2m		
11	Called Party Subaddress	7.7.8	O	I			O	C2m		
12	Repeat Indicator	7.6.3	O	I			O	C2o		
13	Segmented Info	7.7.37	O	I	<Q.65>		O	C2m	<Q.65>	
14	Alphanumeric	7.7.3	O	I	<Q.31>		O		<Q.31>	
15	IWU-to-IWU	7.7.23	O	I	<Q.51>		O	C2m	<Q.51>	
16	IWU-packet	7.7.22	O	I	<Q.50>		O		<Q.50>	

Table G.8: Replacement of table Q.17 of ETS 300 651 [13] PICS: Information element support

Supported information elements						
Item no.	Name	Ref.	Receipt (P to F)		Sending (F to P)	
			Status	Support	Status	Support
3	Repeat indicator (non prioritized)	7.6.3	O	C1o C3o	O	C1o C2o C3o
17	Called party number	7.7.7	O	C1m C3m	O	C1m C2m C3m
18	Called party subaddress	7.7.8	O	C1m C3m	O	C1m C2m C3m
19	Calling party number	7.7.9	O	C1m C3m	O	C1m C2m C3m
21	Connection attributes	7.7.11	O	C1o C3m	O	C1o C3m
31	IWU attributes	7.7.21	O	C1o C3m	O	C1o C3m
33	IWU to IWU	7.7.23	O	C1m	O	C1m C2m
55	MMS-Generic-Header	7.7.47	O	C1m C3m	O	C1m C2m C3m
56	MMS-Object-Header	7.7.48	O	C1m C3m	O	C1m C2m C3m
57	MMS-Extended-Header	7.7.49	O	C1o C3o	O	C1o C2o C3o
58	Time-Date	7.7.50	O	C1m C3m	O	C1m C2m C3m

Table G.9: Replacement of table Q.22 of ETS 300 651 [13] PICS: Basic service implemented

Supported parameters						
Field no.	Name of fields	Ref.	Protocol Status	Supp	Values	
					Allowed	Supported
1	Identifier for double octet	7.6.1	M		6	
2	2nd-ID of basic service of fixed length	7.6.1	M		0	
3	Call class	7.6.4	M		4,8,9,10,11,12,13	4,8
4	Basic service	7.6.4	M		0, 4, 5,6,15	C1o = 5 15

Table G.10: Replacement of table Q.35 of ETS 300 651 [13] PICS: Called party number implemented

Supported parameters						
Field no.	Name of fields	Ref.	Protocol Status	Supp	Values	
					Allowed	Supported
1	ID of called party number	7.7.1	M		112	
2	Length of Contents (L)	7.7.7	M		2-255	
3	Number type	7.7.7	M		0-4,6	
4	Numbering plan identification	7.7.7	M		0,1,3,7-9, 11-14	
5	Called party address(the first DECT character)	7.7.7	M		00,02,03,05-0F,11-14,16,19-1B,20-7F (HEX)	
6	Called party address(list of the rest DECT character)	7.7.7	M		00,02,03,05-0F,11-14,16,19-1B,20-7F (HEX)	

Table G.11: Replacement of table Q.37 of ETS 300 651 [13] PICS: Calling party number implemented

Supported parameters						
Field no.	Name of fields	Ref.	Protocol Status	Supp	Values	
					Allowed	Supported
1	ID of called party number	7.7.1	M		108	
2	Length of Contents (L)	7.7.9	M		2-255	
3	Number type	7.7.9	M		0-4,6	
4	Numbering plan identification	7.7.9	M		0,1,3,7-9, 11-14	
5	Called party address(the first DECT character)	7.7.9	M		00,02,03,05-0F,11-14,16,19-1B,20-7F (HEX)	
6	Called party address(list of the rest DECT character)	7.7.9	M		00,02,03,05-0F,11-14,16,19-1B,20-7F (HEX)	

Table G.12: Replacement of table Q.39 of ETS 300 651 [13] PICS: Connection attributes implemented

Supported parameters						
Field no.	Name of fields	Ref.	Protocol Status	Supp	Values	
					Allowed	Supported
1	ID of connection attributes	7.7.1	M		23	
2	Length of Contents (L)	7.7.11	M		4-9	
3	Symmetry	7.7.11	M		1,4-7	
4	Connection identity	7.7.11	M		0,8-15	8-15
5	Target bearers (P => F direction)	7.7.11	M		0,1-31	C1m = 0 1-23
6	Minimum bearers (P => F direction)	7.7.11	O	O	0,1-31	C1m = 0 1-23
7	Target bearers (F => P direction)	7.7.11	O	C2	0,1-31	C1m = 0 1-23
8	Minimum bearers (F => P direction)	7.7.11	O	C2	0,1-31	C1m = 0 1-23
9	MAC slot size	7.7.11	M		0,4,5	4
10	MAC service (P => F direction)	7.7.11	M		0-3	3
11	MAC service (F => P direction)	7.7.11	O	C2	0-3	3
12	CF channel attributes (P => F direction)	7.7.11	M		0,2-5	2
13	MAC packet life time (P =>F direction)	7.7.11	M		0,8-15	8-15
14	CF channel attributes (F => P direction)	7.7.11	O	C2	0,2-5	2
15	MAC packet life time (F =>P direction)	7.7.11	O	C2	0,8-15	8-15

Table G.13: Replacement of table Q.49 of ETS 300 651 [13] PICS: IWU attributes implemented

Supported parameters						
Field no.	Name of fields	Ref.	Protocol Status	Supp	Values	
					Allowed	Supported
1	ID of IWU attributes of variable length	7.7.1	M		18	
2	Length of Contents (L)	7.7.21	M		4-	
3	Coding standard	7.7.21	M		0,1	
4	Profile	7.7.21	M		0,1,2,3,4,8,9,10,11,12	C1m = 3 C3m = 4
5	Negotiation indicator	7.7.21	M		0,2,4,6	
6	Profile subtype	7.7.21	M		Note	
7	IWU attributes information	7.7.21	O		Note	
NOTE: The codings of the interworking service dependent fields shall be given in the interworking annexes.						

Table G.14: Replacement of table Q.51 of ETS 300 651 [13] PICS: IWU-TO-IWU

Supported parameters						
Field no.	Name of fields	Ref.	Protocol Status	Supp	Values	
					Allowed	Supported
1	ID of IWU attributes of variable length	7.7.1	M		18	
2	Length of Contents (L)	7.7.23	M		4-	
3	Send/Reject	7.7.23	M		0,1	
4	Protocol Discriminator	7.7.23	M		0-2, 4,8-10, 16,17, 20, 63	20
5	Iwu-to-iwu information	7.7.23	M		0 -	

Table G.15: Replacement of table Q.80 of ETS 300 651 [13] PICS: Error & exception handling procedure support

Item no.	Name of procedure	Ref.	Protocol Status	Profile Support
1	eeh_protocol_discriminator_error	17.1	M	
2	eeh_message_too_short	17.2	M	
3	eeh_unsupported_transaction_identity_error	17.3.1	M	
4	eeh_unknown_active_cc_call	17.3.2.1	M	
5	eeh_unknown_active_ciss_call	17.3.2.2	Cciss	I
6	eeh_unknown_active_coms_call	17.3.2.3	Ccoms	I
7	eeh_unknown_active_clms_call	17.3.2.4	Cclms	C2m
8	eeh_unknown_active_mm_transaction	17.3.2.5	M	
9	eeh_cc_message_error	17.4.1	M	
10	eeh_ciss_message_error	17.4.2	Cciss	I
11	eeh_coms_&_clms_message_error	17.4.3	CcomsORclms	C2m
12	eeh_mm_message_error	17.4.4	M	
13	eeh_info_element_out_of_sequence	17.5.1	M	
14	eeh_duplicated_info_elements	17.5.2	M	
15	eeh_mandatory_info_element_missing_in_cc_message	17.6.1	M	
16	eeh_mandatory_info_element_content_error_in_cc_message	17.6.2	M	
17	eeh_mandatory_info_element_missing_in_coms_&_clms_message	17.6.3	CcomsORclms	I
18	eeh_mandatory_info_element_missing_in_mm_message	17.6.4	M	
19	eeh_unrecognised_info_element	17.7.1	M	
20	eeh_non-mandatory_info_element_content_error	17.7.2	M	
21	eeh_data_link_reset	17.8	M	
22	eeh_data_link_failure	17.9	M	

Table G.16: Replacement of table Q.100 of ETS 300 651 [13] PICS: MMS-Generic-Header

Supported parameters						
Field no.	Name of fields	Ref.	Protocol Status	Supp	Values	
					Allowed	Supported
1	ID of MMS-Generic-Header of variable length	7.7.1	M		32	
2	Length of Contents (L)	7.7.47	M		4-	
3	MMS Command type	7.7.47	M		0-13	
4	Reply Requested	7.7.47	M		0-3	
5	Extended MMS command type	7.7.47	O		0, 8, 9, 56-58, 64-66, 72-76	
5	MMS message Identifier	7.7.47	M		0-127	
6	MMS extended message identifier	7.7.47	O		0-127	
7	Service type	7.7.47	O		0-4,8-13,16-20,22, 23,32-39, 96-127	
8	Service subtype	7.7.47	O		0 -	
9	Command outcome	7.7.47	O		0, 1, 4-6, 8-11, 32-40, 48, 64-66, 68-70, 72, 73, 76, 77, 80 - 83	
10	Command outcome - IE support	7.7.47	O		0-127	
11	Command outcome - IE support	7.7.47	O		0-127	

Table G.17: Replacement of table Q.101 of ETS 300 651 [13] PICS: MMS-Object-Header

Supported parameters						
Field no.	Name of fields	Ref.	Protocol Status	Supp	Values	
					Allowed	Supported
1	ID of MMS-Object-Header of variable length	7.7.1	M		33	
2	Length of Contents (L)	7.7.48	M		4-	
3	Length Description	7.7.48	M		0-2	
4	Number of length octets	7.7.48	M		0-7	
5	User data length octets	7.7.48	O		0 -	
6	Source user data category	7.7.48	M		0-3	
7	Source user data transfer encoding	7.7.48	M		0,1,2,4,5,8	
8	Destination user data category	7.7.48	O		0-3	
9	Destination user data transfer encoding	7.7.48	O		0,1,2,4,5,8	
10	Source user data type	7.7.48	M		0, 1, 2, 4, 5, 6, 8-14, 16-20, 32-40, 56, 57, 63-66,69,70, 72-76, 120, 127	
11	Extended Source user data type	7.7.48	O		0-6, 9-12, 16-20, 25-28, 33-36	
12	Destination user data type	7.7.48	O		0, 1, 2, 4, 5, 6, 8-14, 16-20, 32-40, 56, 57, 63-66,69,70, 72-76, 120, 127	
13	Extended destination user data type	7.7.48	O		0-6, 9-12, 16-20, 25-28, 33-36	
14	Multipart parent message identifier	7.7.48	O		0-127	
15	Multipart parent message extended identifier	7.7.48	O		0-127	

Table G.18: Replacement of table Q.102 of ETS 300 651 [13] PICS: MMS-Ext-Header

Supported parameters						
Field no.	Name of fields	Ref.	Protocol Status	Supp	Values	
					Allowed	Supported
1	ID of MMS-Ext-Header of variable length	7.7.1	M		34	
2	Length of Contents (L)	7.7.49	M		4-	
3	Attribute Category	7.7.49	M		0-4	
4	Attribute Identifier	7.7.49	M		0-4	
5	Extended attribute identifier	7.7.49	O		0 -127	
6	Message Attributes	7.7.49	M		0 -	

Table G.19: Replacement of table Q.103 of ETS 300 651 [13] PICS: Time-Date

Supported parameters						
Field no.	Name of fields	Ref.	Protocol Status	Supp	Values	
					Allowed	Supported
1	ID of Time-Date of variable length	7.7.1	M		35	
2	Length of Contents (L)	7.7.50	M		4-	
3	Coding	7.7.50	M		1,2,3	
4	Interpretation	7.7.50	M		0,1,32 - 36, 40	
5	Time and date information	7.7.50	M		0 -	

Annex H (informative): Applicability of ETS 300 757 interworking annexes

The interworking annexes in ETS 300 757 [23] specifying the E.2 profile messaging service are also applicable to this ETS and vice versa. Although consideration has to be taken to the lower data throughput in the E.2 profile, i.e. it is for example not suitable to run a facsimile application on the E.2 profile, but short messages can without problems be send on the F.2 profile.

Annex J (Informative): Interworking to other message-based teleservices and application-level services

J.1 General

The messaging service specified in this ETS also allows efficient interworking to other message-based teleservices and application-level services such as;

- WWW/HTTP;
- e-mail;
- file transfer (FTP, FTAM and ISDN file transfer);
- message waiting.

There may be subsequent amendments to this ETS or separate ETSs to fully specify the interworking for the above services.

J.2 WWW/HTTP

Using the Multimedia Messaging Service for interworking to WWW/HTTP gives the advantage that the PP does not need to have a TCP/IP stack, which would require significant memory and complexity in the PP. This is especially useful to enhance a GAP handset with possibilities to not only receive (short) messages but also to be able to request WWW pages.

Another application might be a PDA with limited memory or a PP designated only for WWW/HTTP applications.

History

Document history			
May 1996	Public Enquiry	PE 106:	1996-05-20 to 1996-09-13
February 1997	Vote	V 9715:	1997-02-11 to 1997-04-11