



EUROPEAN
TELECOMMUNICATION
STANDARD

ETS 300 745-1

July 1997

Source: ETSI TC-SPS

Reference: DE/SPS-05069-1

ICS: 33.020

Key words: ISDN, DSS1, supplementary service, MWI

**Integrated Services Digital Network (ISDN);
Message Waiting Indication (MWI) supplementary service;
Digital Subscriber Signalling System No. one (DSS1) protocol;
Part 1: Protocol specification**

ETSI

European Telecommunications Standards Institute

ETSI Secretariat

Postal address: F-06921 Sophia Antipolis CEDEX - FRANCE

Office address: 650 Route des Lucioles - Sophia Antipolis - Valbonne - FRANCE

X.400: c=fr, a=atlas, p=etsi, s=secretariat - **Internet:** secretariat@etsi.fr

Tel.: +33 4 92 94 42 00 - Fax: +33 4 93 65 47 16

Copyright Notification: No part may be reproduced except as authorized by written permission. The copyright and the foregoing restriction extend to reproduction in all media.

© European Telecommunications Standards Institute 1997. All rights reserved.

Contents

Foreword	5
1 Scope	7
2 Normative references	7
3 Definitions	8
4 Abbreviations	9
5 Description	9
6 Operational requirements	9
6.1 Provision and withdrawal	9
6.2 Requirements on the receiving user's network side	10
6.3 Requirements on the controlling user's network side	10
7 Coding requirements	10
7.1 Coding of the facility information element components	10
8 State definitions	12
9 Signalling procedures at the coincident S and T reference point	13
9.1 Activation at the controlling user's interface	13
9.1.1 Normal operation	13
9.1.2 Exceptional procedures	13
9.2 Deactivation at the controlling user's interface	14
9.2.1 Normal operation	14
9.2.2 Exceptional procedures	15
9.3 Activation at the receiving user's interface	15
9.3.1 Normal operation	15
9.3.2 Exceptional procedures	16
9.4 Deactivation at the receiving user's interface	16
9.4.1 Normal operation	16
9.4.2 Exceptional procedures	16
9.5 Invocation of the MWI to the receiving user	16
9.5.1 Normal operation	16
9.5.1.1 Invocation in the immediate mode	17
9.5.1.2 Invocation in the deferred mode	17
9.5.1.3 Invocation in the combined mode	18
9.5.2 Exceptional procedures	18
10 Procedures for interworking with private ISDNs	18
10.1 Activation of the message waiting indication where the controlling user resides in a private network	18
10.1.1 Normal procedures	18
10.1.2 Exceptional procedures	19
10.2 Deactivation of the message waiting indication where the controlling user resides in a private network	19
10.2.1 Normal procedures	19
10.2.2 Exceptional procedures	20
10.3 Activation of the message waiting indication where the receiving user resides in a private ISDN	21
10.3.1 Normal operation	21
10.3.2 Exceptional procedures	21

10.4	Deactivation of the message waiting indication where the receiving user resides in a private ISDN	22
10.4.1	Normal procedures	22
10.4.2	Exceptional procedures	23
11	Interaction with other networks	23
12	Interaction with other supplementary services.....	23
13	Parameter values (timers)	23
14	Dynamic description (SDL diagrams)	24
14.1	Controlling user	24
14.1.1	Controlling user - user side.....	24
14.1.1.1	Controlling user - user side (coincident S and T reference point)	24
14.1.1.2	Controlling user - user side (T reference point)	26
14.1.2	Controlling user - network side	28
14.1.2.1	Controlling user - network side (coincident S and T reference point).....	28
14.1.2.2	Controlling user - network side (T reference point).....	30
14.2	Receiving user.....	32
14.2.1	Receiving user - user side	32
14.2.1.1	Receiving user - user side (coincident S and T reference point)	32
14.2.1.2	Receiving user - user side (T reference point).....	33
14.2.2	Receiving user - network side.....	35
14.2.2.1	Receiving user - network side (coincident S and T reference point).....	35
14.2.2.2	Receiving user - network side (T reference point)	37
Annex A (informative):	Signalling flows	39
Annex B (informative):	Assignment of object identifier values	41
History		42

Foreword

This European Telecommunication Standard (ETS) has been produced by the Signalling Protocols and Switching (SPS) Technical Committee of the European Telecommunications Standards Institute (ETSI).

This ETS is part 1 of a multi-part standard covering the Digital Subscriber Signalling System No. one (DSS1) protocol specification for the Integrated Services Digital Network (ISDN) Message Waiting Indication (MWI) supplementary service, as described below:

Part 1: "Protocol specification";

Part 2: "Protocol Implementation Conformance Statement (PICS) proforma specification";

Part 3: "Test Suite Structure and Test Purposes (TSS&TP) specification for the user";

Part 4: "Abstract Test Suite (ATS) and partial Protocol Implementation eXtra Information for Testing (PIXIT) proforma specification for the user";

Part 5: "TSS&TP specification for the network";

Part 6: "ATS and partial PIXIT proforma specification for the network".

In accordance with CCITT Recommendation I.130, the following three level structure is used to describe the supplementary telecommunication services as provided by European public telecommunications operators under the pan-European ISDN:

- Stage 1: is an overall service description, from the user's standpoint;
- Stage 2: identifies the functional capabilities and information flows needed to support the service described in stage 1; and
- Stage 3: defines the signalling system protocols and switching functions needed to implement the service described in stage 1.

This ETS details the stage 3 aspects (signalling system protocols and switching functions) needed to support the MWI supplementary service. The stage 1 aspects are detailed in ETS 300 650. The stage 2 aspects of the MWI supplementary service have not been specified.

Transposition dates	
Date of adoption:	20 June 1997
Date of latest announcement of this ETS (doa):	31 October 1997
Date of latest publication of new National Standard or endorsement of this ETS (dop/e):	30 April 1998
Date of withdrawal of any conflicting National Standard (dow):	30 April 1998

Blank page

1 Scope

This first part of ETS 300 745 specifies the stage three of the Message Waiting Indication (MWI) supplementary service for the pan-European Integrated Services Digital Network (ISDN) as provided by European public telecommunications operators at the T reference point or coincident S and T reference point (as defined in ITU-T Recommendation I.411 [7]) by means of the Digital Subscriber Signalling System No. one (DSS1) protocol. Stage three identifies the protocol procedures and switching functions needed to support a telecommunication service (see CCITT Recommendation I.130 [5]).

In addition, this ETS specifies the protocol requirements at the T reference point where the service is provided to the user via an intermediate private ISDN.

This ETS does not specify the additional protocol requirements where the service is provided to the user via a telecommunication network that is not an ISDN but it does include interworking requirements of other networks with the public ISDN.

The MWI supplementary service is provided independently of a call and is therefore applicable to a number of telecommunication services.

Charging principles are outside the scope of this ETS.

The MWI supplementary service enables the network, upon request of a controlling user to indicate to the receiving user, that there is at least one message waiting.

NOTE: The MWI supplementary service is typically used between a mailbox service provider (controlling user) and a user (receiving user) of the mailbox service provided .

Further parts of this ETS specify the method of testing required to identify conformance to this ETS.

This ETS is applicable to equipment supporting the MWI supplementary service, to be attached at either side of a T reference point or coincident S and T reference point when used as an access to the public ISDN.

2 Normative references

This ETS incorporates by dated or undated reference, provisions from other publications. These normative references are cited at the appropriate places in the text and the publications are listed hereafter. For dated references, subsequent amendments to or revisions of any of these publications apply to this ETS only when incorporated in it by amendment or revision. For undated references the latest edition of the publication referred to applies.

- [1] EN 300 195-1 (V1.2): "Integrated Services Digital Network (ISDN); Supplementary service interactions; Digital Subscriber Signalling System No. one (DSS1) protocol; Part 1: Protocol specification".
- [2] ETS 300 196-1: "Integrated Services Digital Network (ISDN); Generic functional protocol for the support of supplementary services; Digital Subscriber Signalling System No. one (DSS1) protocol; Part 1: Protocol specification".
- [3] ITU-T Recommendation E.164 (1993): "Numbering plan for the ISDN era".
- [4] ITU-T Recommendation I.112 (1993): "Vocabulary of terms for ISDNs".
- [5] CCITT Recommendation I.130 (1988): "Method for the characterization of telecommunication services supported by an ISDN and network capabilities of an ISDN".
- [6] ITU-T Recommendation I.210 (1993): "Principles of telecommunication services supported by an ISDN and the means to describe them".
- [7] ITU-T Recommendation I.411 (1993): "ISDN user-network interfaces - Reference configurations".

- [8] CCITT Recommendation Q.9 (1988): "Vocabulary of switching and signalling terms".
- [9] CCITT Recommendation X.208 (1988): "Specification of Abstract Syntax Notation One (ASN.1)".
- [10] CCITT Recommendation X.219 (1988): "Remote Operations: Model, notation and service definition".
- [11] ITU-T Recommendation Z.100 (1993): "Specification and Description Language (SDL)".

3 Definitions

For the purposes of this ETS, the following definitions apply:

basic access: See CCITT Recommendation Q.9 [8], definition 1551.

basic call procedures: The procedures by which a call (as an instance of a telecommunications service) is established and terminated.

controlling user: The user that activates and deactivates the message waiting indication.

NOTE 1: The controlling user is likely to be a voice mail box.

Integrated Services Digital Network (ISDN): See ITU-T Recommendation I.112 [4], definition 308.

ISDN number: A number conforming to the numbering plan and structure specified in CCITT Recommendation E.164 [3].

invoke component: See ETS 300 196-1 [2], subclause 8.2.2.1. Where reference is made to a "xxxx" invoke component, an invoke component is meant with its operation value set to the value of the operation "xxxx".

mail box: A system, inside or outside the public network infrastructure, capable to handle mail.

NOTE 2: The definition of the mail box service is outside the scope of this ETS.

network: The DSS1 protocol entity at the network side of the user-network interface.

public network: The DSS1 protocol entity at the network side of the user-network interface at the T reference point.

primary rate access: See CCITT Recommendation Q.9 [8], definition 1552.

private network: The DSS1 protocol entity at the user side of the user-network interface at the T reference point.

receiving user: The user that receives the message waiting indication.

reject component: See ETS 300 196-1 [2], subclause 8.2.2.4.

return error component: See ETS 300 196-1 [2], subclause 8.2.2.3. Where reference is made to a "xxxx" return error component, a return error component is meant which is related to a "xxxx" invoke component.

return result component: See ETS 300 196-1 [2], subclause 8.2.2.2. Where reference is made to a "xxxx" return result component, a return result component is meant which is related to a "xxxx" invoke component.

service; telecommunication service: See ITU-T Recommendation I.112 [4], definition 201.

supplementary service: See ITU-T Recommendation I.210 [6], subclause 2.4.

user: The DSS1 protocol entity at the user side of the user-network interface.

4 Abbreviations

For the purposes of this ETS, the following abbreviations apply:

ASN.1	Abstract Syntax Notation One
DSS1	Digital Subscriber Signalling System No. one
ISDN	Integrated Services Digital Network
MWI	Message Waiting Indication
SDL	Specification and Description Language

5 Description

The MWI supplementary service shall be available to users who are connected to the network via a basic access or primary rate access.

The MWI supplementary service enables the network, upon the request of a controlling user to indicate to the receiving user, that there is at least one message waiting. The indication is delivered to the receiving user:

- when the MWI supplementary service is activated for a certain basic service and the receiving user makes an outgoing call attempt; and/or
- as soon as the MWI supplementary service has been activated or deactivated.

NOTE: Having received this indication, the receiving user can subsequently access the mail box, to have the mail delivered. The means by which the receiving user accesses and manages the mail box are outside the scope of this ETS.

The controlling user can activate and deactivate the message waiting indication when appropriate.

6 Operational requirements

6.1 Provision and withdrawal

The MWI supplementary service shall be provided to the controlling user after prior arrangements with the service provider. The MWI supplementary service shall be withdrawn at the controlling user's request, or for administrative reasons.

The MWI supplementary service shall be provided to the receiving user after prior arrangements with the service provider. The MWI supplementary service shall be withdrawn at the receiving user's request, or for administrative reasons. As a network option, the receiving user can have a subscription option to register the controlling user numbers that can activate and deactivate the MWI supplementary service.

Table 1: Network options

Network options	Values
Support of subscription option for registration of the ISDN number(s) of the controlling user(s)	- yes - no
Provide additional information during deferred invocation	- yes - no
Maximum number of controlling users' ISDN numbers registered by the network	any integer value
Maximum number of active instances per receiving user	any integer value

The maximum number of ISDN numbers that can be registered for a receiving user is a network option.

Provision of the MWI supplementary service shall be possible on an access or ISDN number basis.

In addition, the subscription options shown in table 2 shall be made available to the receiving user.

Table 2: Subscription options

Subscription options	Values
Invocation mode	a) deferred mode: invocation when the supplementary service is activated and the receiving user makes an outgoing call; b) immediate mode: invocation as soon as the supplementary service has been activated or deactivated; c) combined mode: in this case both the deferred and immediate mode apply.
Override of invocation mode by controlling user allowed	- yes - no
Registration of the ISDN number(s) of the controlling user(s)	- yes - no

6.2 Requirements on the receiving user's network side

The network shall register whether the procedures of clause 9 or clause 10 of this ETS shall apply.

6.3 Requirements on the controlling user's network side

The network shall register whether the procedures of clause 9 or clause 10 of this ETS shall apply.

7 Coding requirements

7.1 Coding of the facility information element components

Table 3 shows the definitions of the operations and errors required for the MWI supplementary service using ASN.1 as specified in CCITT Recommendation X.208 [9] and using the OPERATION and ERROR macros as defined in figure 4 of CCITT Recommendation X.219 [10].

The formal definition of the component types to encode these operations and errors is provided in clause D.1 of ETS 300 196-1 [2].

The inclusion of components in Facility information elements is defined in ETS 300 196-1 [2], subclause 11.2.2.1.

All components (invoke, return result, return error and reject) shall be included within a Facility information element. This Facility information element may be included in any appropriate message as specified in ETS 300 196-1 [2], subclause 8.3.1.1, unless a more restrictive specification is given in clause 9 of this ETS.

Table 3: Definition of operations and errors for the MWI supplementary service

```

MWI-Operations-and-Errors {ccitt identified-organization etsi(0) 745 operations-and-errors(1)}
DEFINITIONS EXPLICIT TAGS ::=
BEGIN
EXPORTS
    MWIActivate,
    MWIDeactivate,
    MWIIndicate,
    InvalidReceivingUserNr,
    ReceivingUserNotSubscribed,
    ControllingUserNotRegistered,
    MaxNumOfControllingUsersReached,
    MaxNumOfActiveInstancesReached
;
IMPORTS
    OPERATION,
    ERROR
    FROM Remote-Operation-Notation
        {joint-iso-ccitt remote-operations(4) notation(0)}

    notSubscribed,
    supplementaryServiceInteractionNotAllowed,
    resourceUnavailable,
    invalidServedUserNr
    FROM General-Errors
        {ccitt identified-organization etsi(0) 196 general-errors(2)}

    BasicService
    From Basic-Service-Elements
        {ccitt identified-organization etsi(0) 196 basic-service-elements(8)}

    PartyNumber
    FROM Addressing-Data-Element
        {ccitt identified-organization etsi(0) 196 addressing-data-elements(6)}
;

MWIActivate ::= OPERATION
    ARGUMENT SEQUENCE {
        receivingUserNr          PartyNumber,
        basicService              BasicService,
        controllingUserNr         [1] PartyNumber    OPTIONAL,
        numberOfMessages          [2] MessageCounter OPTIONAL,
        controllingUserProvidedNr [3] PartyNumber    OPTIONAL,
        time                      [4] GeneralizedTime OPTIONAL,
        messageId                 [5] MessageID     OPTIONAL,
        mode                      [6] InvocationMode OPTIONAL}
    RESULT
    ERRORS {
        notSubscribed,
        supplementaryServiceInteractionNotAllowed,
        resourceUnavailable,
        invalidReceivingUserNr,
        invalidServedUserNr,
        receivingUserNotSubscribed,
        controllingUserNotRegistered,
        indicationNotDelivered,
        maxNumOfControllingUsersReached,
        maxNumOfActiveInstancesReached }
-- End of MWIActivate operation definition

MWIDeactivate ::= OPERATION
    ARGUMENT SEQUENCE {
        receivingUserNr          PartyNumber,
        basicService              BasicService,
        controllingUserNr         PartyNumber    OPTIONAL,
        mode                      InvocationMode OPTIONAL }
    RESULT
    ERRORS {
        notSubscribed,
        supplementaryServiceInteractionNotAllowed,
        resourceUnavailable,
        invalidReceivingUserNr,
        invalidServedUserNr,
        receivingUserNotSubscribed,
        controllingUserNotRegistered,
        indicationNotDelivered }
-- End of MWIDeactivate operation definition

```

Table 3 (concluded): Definition of operations and errors for the MWI supplementary service

```

MWIIndicate ::= OPERATION
              ARGUMENT SEQUENCE {
                controllingUserNr      [1] PartyNumber      OPTIONAL,
                basicService            [2] BasicService      OPTIONAL,
                numberOfMessages        [3] MessageCounter    OPTIONAL,
                controllingUserProvidedNr [4] PartyNumber      OPTIONAL,
                time                    [5] GeneralizedTime    OPTIONAL,
                messageId               [6] MessageID          OPTIONAL}
-- End of MWIIndicate operation definition

InvalidReceivingUserNr      ::= ERROR
ReceivingUserNotSubscribed  ::= ERROR
ControllingUserNotRegistered ::= ERROR
IndicationNotDelivered      ::= ERROR
MaxNumOfControllingUsersReached ::= ERROR
MaxNumOfActiveInstancesReached ::= ERROR

MessageCounter ::= INTEGER (0..65535)

GeneralizedTime ::= [UNIVERSAL 24] IMPLICIT VisibleString

MessageID ::= SEQUENCE {
              messageRef MessageRef,
              status      MessageStatus}

MessageRef ::= INTEGER (0..65535)

MessageStatus ::= ENUMERATED (
              addedMessage (0),
              removedMessage (1))

InvocationMode ::= ENUMERATED (
              deferred (0),
              immediate (1),
              combined (2))

mWIOID OBJECT IDENTIFIER ::= {ccitt identified-organization etsi(0) 745
              operations-and-errors(1)}

mWIActivate MWIActivate ::= globalValue {mWIOID 1}
mWIDeactivate MWIDeactivate ::= globalValue {mWIOID 2}
mWIIIndicate MWIIIndicate ::= globalValue {mWIOID 3}

invalidReceivingUserNr InvalidReceivingUserNr ::= globalValue {mWIOID 10}
receivingUserNotSubscribed ReceivingUserNotSubscribed ::= globalValue {mWIOID 11}
controllingUserNotRegistered ControllingUserNotRegistered ::= globalValue {mWIOID 12}
indicationNotDelivered IndicationNotDelivered ::= globalValue {mWIOID 13}
maxNumOfControllingUsersReached MaxNumOfControllingUsersReached ::= globalValue {mWIOID 14}
maxNumOfActiveInstancesReached MaxNumOfActiveInstancesReached ::= globalValue {mWIOID 15}

END -- MWI-Operations-and-Errors

```

8 State definitions

Table 4 defines the states for the MWI supplementary service.

Table 4: States for MWI supplementary service

Controlling user states	
Idle	The MWI supplementary service is idle
Activation Requested	The user has requested activation and is waiting for a response
Deactivation Requested	The user has requested deactivation and is waiting for a response
Network states	
Idle	The MWI supplementary service is idle
MWI Active (note 1)	The MWI supplementary service has been activated
Activation Requested (note 2)	The network has received activation request
Deactivation Requested (note 2)	The network has received deactivation request
NOTE 1:	Only applicable for the receiving user's network when the procedures of clause 9 apply.
NOTE 2:	Applicable for the controlling user's network and for the receiving user's network when the procedures of clause 10 apply.

9 Signalling procedures at the coincident S and T reference point

9.1 Activation at the controlling user's interface

9.1.1 Normal operation

To activate the MWI supplementary service, the controlling user shall send a MWIActivate invoke component to the network using the procedure described in subclause 10.2.2.1 of ETS 300 196-1 [2].

The controlling user shall indicate:

- in the "basicService" parameter, the basic service to which the activation of the MWI supplementary service activation applies;
- in the "receivingUserNr" parameter, the ISDN number of the receiving user for which the activation applies; and
- optionally, in the "numberOfMessages" parameter the number of messages present;
- optionally, in the "controllingUserProvidedNr" parameter the ISDN number provided by the controlling user e.g. the ISDN number of the originating user of the indicated message;
- optionally, in the "time" parameter the date and time provided by the controlling user of the indicated message;
- optionally in the "controllingUserNr" parameter, the ISDN number of the controlling user from which the MWI service activation is requested;
- optionally, in the "messageld" parameter, a reference of the related message and an indication whether the message is added or removed; and
- optionally, in the "mode" parameter the applicable invocation mode.

On receipt of an MWIActivate invoke component the controlling user's network shall inform the receiving user's network of the request and wait for a response.

When the controlling user's network is informed of the acceptance of the activation, the controlling user's network shall send a MWIActivate return result component to the controlling user using the procedures of subclause 10.2.2.1 of ETS 300 196-1 [2].

When the controlling user receives a correctly encoded MWIActivate return result component, then the controlling user shall accept the provided information and the MWI supplementary service is successfully activated.

9.1.2 Exceptional procedures

If the network is not able to activate the MWI supplementary service, the controlling user's network shall send a MWIActivate return error component to the controlling user within a Facility information element, using the procedure in subclause 10.2.2.2 of ETS 300 196-1 [2], indicating one of the following error values:

- "notSubscribed", if (for a given ISDN number or for the whole access) the MWI supplementary service has not been subscribed to by the controlling user;
- "invalidReceivingUserNr", if the ISDN number provided to identify the receiving user is not a valid number;
- "supplementaryServiceInteractionNotAllowed", if the provision of the MWI supplementary service is precluded by a procedure within EN 300 195-1 [1], clause 5;
- "resourceUnavailable", if the resources required to perform adequately the MWI supplementary service are not available. This error shall be used to indicate a congestion situation;

- "invalidServedUserNr", if the ISDN number provided to identify the controlling user is not a valid number;
- "receivingUserNotSubscribed", if the MWI supplementary service has not been subscribed to by the receiving user;
- "controllingUserNotRegistered", if the controlling user is not allowed to activate the MWI supplementary service for the receiving user;
- "indicationNotDelivered", if the controlling user's network has not received a response from the receiving user's network;
- "maxNumOfControllingUsersReached", if the receiving user's network cannot handle any further controlling users.
- "maxNumOfActiveInstancesReached", this error value shall be used when the maximum number of activations for the receiving user has been reached and a further activation has been requested.

On receipt of a MWIActivate return error component, the controlling user shall stop T-ACTIVATE and shall consider that this attempt to activate the MWI supplementary service has failed.

On expiration of timer T-ACTIVATE and the controlling user not having received any response to the MWIActivate invoke component, the result of the activation request is undetermined.

If a reject component is received by either the controlling user or the controlling user's network and the invoke identifier is included, the reject component shall be ignored.

9.2 Deactivation at the controlling user's interface

9.2.1 Normal operation

To deactivate the MWI supplementary service, the controlling user shall send a MWIDeactivate invoke component to the network using the procedures described in subclause 10.2.3.1 of ETS 300 196-1 [2].

The controlling user shall indicate:

- in the "basicService" parameter, the basic service to which the deactivation of the MWI supplementary service activation applies;
- in the "receivingUserNr" parameter, the ISDN number of the receiving user for which the deactivation applies;
- optionally, in the "controllingUserNr" parameter, the ISDN number of the controlling user from which the MWI supplementary service deactivation is requested; and
- optionally, in the "mode" parameter the applicable invocation mode.

On receipt of an MWIDeactivate invoke component the controlling user's network shall inform the receiving user's network of the request and wait for a response.

When the controlling user's network is informed of the acceptance of the deactivation request, the controlling user's network shall send a MWIDeactivate return result component to the controlling user using the procedures of subclause 10.2.3.1 of ETS 300 196-1 [2].

When the controlling user receives a correctly encoded MWIDeactivate return result component, then the controlling user shall accept the provided information and the MWI supplementary service is successfully deactivated.

9.2.2 Exceptional procedures

If the network is unable to deactivate the MWI supplementary service, the controlling user's network shall send a MWIDeactivate return error component to the controlling user within a Facility information element, using the procedure described in subclause 10.2.3.2 of ETS 300 196-1 [2], indicating one of the following error values:

- "notSubscribed", if (for a given ISDN number or for the whole access) the MWI supplementary service has not been subscribed to by the controlling user;
- "invalidReceivingUserNr", if the ISDN number provided to identify the receiving user is not a valid number;
- "supplementaryServiceInteractionNotAllowed", if the provision of the MWI supplementary service is precluded by a procedure within EN 300 195-1 [1], clause 5;
- "resourceUnavailable", if the resources required to perform adequately the MWI supplementary service are not available. This error shall be used to indicate a congestion situation;
- "invalidServedUserNr", if the ISDN number provided to identify the controlling user is not a valid number;
- "receivingUserNotSubscribed", if the MWI supplementary service has not been subscribed to by the receiving user;
- "controllingUserNotRegistered", if the controlling user is not allowed to deactivate the MWI supplementary service for the receiving user;
- "indicationNotDelivered", if the controlling user's network has not received a response from the receiving user's network.

On receipt of a MWIDeactivate return error component, the controlling user shall stop T-DEACTIVATE and shall consider that this attempt to deactivate the MWI supplementary service has failed.

On expiration of timer T-DEACTIVATE and the controlling user not having received any response to the MWIDeactivate invoke component, the result of the deactivation request is undetermined.

If a reject component is received by either the controlling user or the controlling user's network and the invoke identifier is included, the reject component shall be ignored.

9.3 Activation at the receiving user's interface

9.3.1 Normal operation

On receipt of an activation request from the controlling user's network, the receiving user's network shall use the basicService, controllingUserNr and receivingUserNr parameters to decide which instance of the MWI supplementary service shall be activated.

Furthermore the receiving user's network shall determine the appropriate invocation mode: if the receiving user has not subscribed to the override mode or the controlling user did not indicate an invocation mode, the resulting invocation mode is the invocation mode subscribed to by the receiving user. If the receiving user has subscribed to the override mode and the controlling user did indicate an invocation mode, the resulting invocation mode is the indicated one.

In case the resulting invocation mode is "deferred mode" and the receiving user's network accepts the activation request, the receiving user's network shall inform the controlling user's network accordingly and activate the indicated instance.

In case the resulting invocation mode is "immediate mode" and the receiving user's network accepts the activation request, the receiving user's network shall inform the controlling user's network accordingly and invoke the MWI supplementary service as specified in subclause 9.5.1.

In case the resulting invocation mode is "combined mode" and the receiving user's network accepts the activation request, the receiving user's network shall inform the controlling user's network accordingly, invoke the MWI supplementary service as specified in subclause 9.5.1, and activate the indicated instance.

When this instance of the MWI supplementary service is already active, the new activation shall replace the existing activation.

9.3.2 Exceptional procedures

If the receiving user's network cannot accept the request to activate the MWI supplementary service, the receiving user's network shall inform the controlling user's network accordingly and provide the reason.

9.4 Deactivation at the receiving user's interface

9.4.1 Normal operation

On receipt of a deactivation request from the controlling user's network, the receiving user's network shall use the basicService, controllingUserNr and receivingUserNr parameters to decide which instance of the MWI supplementary service shall be deactivated.

Furthermore the receiving user's network shall determine the appropriate invocation mode: if the receiving user has not subscribed to the override mode or the controlling user did not indicate an invocation mode, the resulting invocation mode is the invocation mode subscribed to by the receiving user. If the receiving user has subscribed to the override mode and the controlling user did indicate an invocation mode, the resulting invocation mode is the indicated one.

In case the resulting invocation mode is "deferred mode" and the receiving user's network accepts the deactivation request, the receiving user's network shall inform the controlling user's network accordingly and deactivate the indicated instance.

In case the resulting invocation mode is "immediate mode" and the receiving user's network accepts the deactivation request, the receiving user's network shall inform the controlling user's network accordingly and invoke the MWI supplementary service as specified in subclause 9.5.1.

In case the resulting invocation mode is "combined mode" and the receiving user's network accepts the deactivation request, the receiving user's network shall inform the controlling user's network accordingly, invoke the MWI supplementary service as specified in subclause 9.5.1, and deactivate the indicated instance.

9.4.2 Exceptional procedures

If the receiving user's network cannot accept the request to deactivate the MWI supplementary service, the receiving user's network shall inform the controlling user's network accordingly and provide the reason.

9.5 Invocation of the MWI to the receiving user

9.5.1 Normal operation

As a receiving user's subscription option, three modes of invocation are available:

- a) invocation when the MWI supplementary service is activated and the receiving user makes an outgoing call (deferred invocation mode);
- b) invocation immediately after activation or deactivation (immediate invocation mode);
- c) a combination of deferred and immediate invocation (combined invocation mode).

9.5.1.1 Invocation in the immediate mode

When the receiving user's network successfully activates an instance of the MWI supplementary service for which the immediate mode applies, the receiving user's network shall send a MWIIndicate invoke component to the receiving user in a Facility information element according to the procedures of subclause 8.3.2.4 of ETS 300 196-1 [2].

The receiving user's network shall indicate:

- in the "controllingUserNr" parameter the ISDN number of the controlling user;
- in the "basicService" parameter, the basic service as indicated by the controlling user;
- if provided by the controlling user, the number of messages waiting for the receiving user and basic service in the "numberOfMessages" parameter;
- if provided by the controlling user, in the "controllingUserProvidedNr" parameter the ISDN number provided by the controlling user;
- if provided by the controlling user, in the "time" parameter the date and time provided by the controlling user; and
- if provided by the controlling user, in the "messageld" parameter, the reference and status of the indicated message.

When the receiving user's network successfully deactivates an instance of the MWI supplementary service for which the immediate mode applies, the receiving user's network shall send a MWIIndicate invoke component to the receiving user in a Facility information element according to the procedures of subclause 8.3.2.4 of ETS 300 196-1 [2].

The network shall indicate:

- in the "controllingUserNr" parameter the ISDN number of the controlling user;
- in the "basicService" parameter, the basic service as indicated by the controlling user; and
- in the "numberOfMessages" parameter the value 0.

9.5.1.2 Invocation in the deferred mode

The MWI supplementary service shall be invoked after receipt of each SETUP message from the receiving user until the network receives a deactivation request for all instances of the MWI supplementary service.

If the network does not support the option to "Provide additional information during deferred invocation" the receiving user's network shall send a MWIIndicate invoke component to the receiving user in a Facility information element according to the procedures of subclause 8.3.2.4 of ETS 300 196-1 [2]. The receiving user's network shall not include any parameters. The information provided shall be independent of the basic service indicated in the SETUP message.

If the network supports the option to "Provide additional information during deferred invocation" the receiving user's network shall send per instance a MWIIndicate invoke component to the receiving user in a Facility information element according to the procedures of subclause 8.3.2.4 of ETS 300 196-1 [2]. The information provided shall be independent of the basic service indicated in the SETUP message. The receiving user's network shall include in every MWIIndicate invoke component:

- in the "controllingUserNr" parameter the ISDN number of the controlling user;
- in the "basicService" parameter, the basic service as indicated by the controlling user; and
- if provided by the controlling user, the number of messages waiting for the receiving user and basic service in the "numberOfMessages" parameter;

- if provided by the controlling user, in the "controllingUserProvidedNr" parameter the ISDN number provided by the controlling user in the last activation; and
- if provided by the controlling user, in the "time" parameter the date and time provided by the controlling user in the last activation.

NOTE: After having finalized or released the call, user A can make a new outgoing call to his mailbox to play the registered messages.

On receipt of a correctly encoded MWIIndicate invoke component, the receiving user shall accept the provided information.

9.5.1.3 Invocation in the combined mode

The procedures of subclause 9.5.1.1 and 9.5.1.2 shall apply.

9.5.2 Exceptional procedures

If a reject component is received and the invoke identifier is included, the network shall ignore this component.

10 Procedures for interworking with private ISDNs

10.1 Activation of the message waiting indication where the controlling user resides in a private network

10.1.1 Normal procedures

When the private network is informed that the controlling user requests activation of the MWI supplementary service, the private network shall send a MWIActivate invoke component to the public network and start timer T-ACTIVATE using the procedure described in subclause 8.3.2.1.1 of ETS 300 196-1 [2].

The private network shall indicate:

- in the "basicService" parameter, the basic service to which the activation of the MWI supplementary service activation applies;
- in the "receivingUserNr" parameter, the ISDN number of the receiving user for which the activation applies; and
- optionally, in the "controllingUserNr" parameter, the ISDN number of the controlling user from which the MWI supplementary service activation is requested;
- optionally, in the "controllingUserProvidedNr" parameter the ISDN number provided by the controlling user e.g. the ISDN number of the originating user of the indicated message;
- optionally, in the "time" parameter the date and time provided by the controlling user of the indicated message;
- optionally, in the "messageld" parameter, a reference of the related message and an indication whether the message is added or removed; and
- optionally, in the "mode" parameter the applicable invocation mode.

When accepting the activation, the public network shall send a MWIActivate return result component to the private network using the procedures of subclause 8.3.2.1.3 of ETS 300 196-1 [2].

When the private network receives a correctly encoded MWIActivate return result component, then the private network shall stop timer T-ACTIVATE, accept the provided information and the MWI supplementary service is successfully activated. Furthermore the private network shall continue clearing of the signalling connection according to subclause 8.3.2.1.3 of ETS 300 196-1 [2].

10.1.2 Exceptional procedures

If the public network is not able to activate the MWI supplementary service, the public network shall send a MWIActivate return error component to the private network within a Facility information element, using the procedure in subclause 8.3.2.1.3 of ETS 300 196-1 [2], indicating one of the following error values:

- "invalidReceivingUserNr", if the ISDN number provided to identify the receiving user is not a valid number;
- "supplementaryServiceInteractionNotAllowed", if the provision of the MWI supplementary service is precluded by a procedure within EN 300 195-1 [1], clause 5;
- "resourceUnavailable", if the resources required to perform adequately the MWI supplementary service are not available. This error shall be used to indicate a congestion situation;
- "invalidServedUserNr", if the ISDN number provided to identify the controlling user is not a valid number;
- "receivingUserNotSubscribed", if the MWI supplementary service has not been subscribed to by the receiving user;
- "controllingUserNotRegistered", if the controlling user is not allowed to activate the MWI supplementary service for the receiving user;
- "notSubscribed", if the MWI supplementary service has not been subscribed to by the private network;
- "indicationNotDelivered", if the controlling user's network has not received a response from the receiving user's network;
- "maxNumOfControllingUsersReached", if the receiving user's network cannot handle any further controlling users; or
- "maxNumOfActiveInstancesReached", this error value shall be used when the maximum number of activations for the receiving user has been reached and a further activation has been requested.

On receipt of a MWIActivate return error component, the private network shall stop T-ACTIVATE, forward the information to the controlling user and shall continue clearing of the signalling connection according to subclause 8.3.2.1.3 of ETS 300 196-1 [2].

On expiration of timer T-ACTIVATE and the private network not having received any response to the MWIActivate invoke component, the result of the activation request is undetermined and the private network shall initiate clearing of the signalling connection according to the procedures of subclause 8.3.2.1.3 of ETS 300 196-1 [2].

If a reject component is received by the private or public network and the invoke identifier is included, the reject component shall be ignored.

10.2 Deactivation of the message waiting indication where the controlling user resides in a private network

10.2.1 Normal procedures

When the private network is informed that the controlling user requests deactivation of the MWI supplementary service, the private network shall send a MWIDeactivate invoke component to the public network and start timer T-DEACTIVATE using the procedures described in subclause 8.3.2.1.1 of ETS 300 196-1 [2].

The private network shall indicate:

- in the "basicService" parameter, the basic service to which the deactivation of the MWI supplementary service activation applies;
- in the "receivingUserNr" parameter, the ISDN number of the receiving user for which the deactivation applies;
- optionally, in the "controllingUserNr" parameter, the ISDN number of the controlling user from which the MWI supplementary service deactivation is requested; and
- if provided by the controlling user, in the "mode" parameter the applicable invocation mode.

When accepting the deactivation, the public network shall send a MWIDeactivate return result component to the private network using the procedures of subclause 8.3.2.1.3 of ETS 300 196-1 [2].

When the private network receives a correctly encoded MWIDeactivate return result component, then the private network shall stop timer T-DEACTIVATE, accept the provided information and the MWI supplementary service is successfully deactivated. Furthermore, the private network shall continue call clearing of the signalling connection according to subclause 8.3.2.1.3 of ETS 300 196-1 [2].

10.2.2 Exceptional procedures

If the public network is unable to deactivate the MWI supplementary service, the public network shall send a MWIDeactivate return error component to the private network within a Facility information element, using the procedure described in subclause 8.3.2.1.3 of ETS 300 196-1 [2], indicating one of the following error values:

- "invalidReceivingUserNr", if the ISDN number provided to identify the receiving user is not a valid number;
- "supplementaryServiceInteractionNotAllowed", if the provision of the MWI supplementary service is precluded by a procedure within EN 300 195-1 [1], clause 5;
- "resourceUnavailable", if the resources required to perform adequately the MWI supplementary service are not available. This error shall be used to indicate a congestion situation;
- "invalidServedUserNr", if the ISDN number provided to identify the controlling user is not a valid number;
- "receivingUserNotSubscribed", if the MWI supplementary service has not been subscribed to by the receiving user;
- "controllingUserNotRegistered", if the controlling user is not allowed to activate the MWI supplementary service for the receiving user;
- "notSubscribed", if the MWI supplementary service has not been subscribed to by the private network; or
- "indicationNotDelivered", if the controlling user's network has not received a response from the receiving user's network.

On receipt of a MWIDeactivate return error component, the private network shall stop T-DEACTIVATE, forward the information to the controlling user and shall continue clearing of the signalling connection according to subclause 8.3.2.1.3 of ETS 300 196-1 [2].

On expiration of timer T-DEACTIVATE and the private network not having received any response to the MWIDeactivate invoke component, the result of the deactivation request is undetermined and the private network shall initiate clearing of the signalling connection according to the procedures of subclause 8.3.2.1.3 of ETS 300 196-1 [2].

If a reject component is received by the private or public network and the invoke identifier is included, the reject component shall be ignored.

10.3 Activation of the message waiting indication where the receiving user resides in a private ISDN

10.3.1 Normal operation

When the public network is informed that the controlling user requests activation of the MWI supplementary service, the public network shall send a MWIActivate invoke component to the private network and start timer T-ACTIVATE using the procedure described in subclause 8.3.2.1.1 of ETS 300 196-1 [2].

The public network shall indicate:

- in the "controllingUserNr" parameter, the ISDN number of the controlling user from which the MWI supplementary service activation is requested;
- in the "basicService" parameter, the basic service to which the activation of the MWI supplementary service activation applies;
- in the "receivingUserNr" parameter, the ISDN number of the receiving user for which the activation applies; and
- optionally, in the "controllingUserProvidedNr" parameter the ISDN number provided by the controlling user e.g. the ISDN number of the originating user of the indicated message; and
- optionally, in the "time" parameter the date and time provided by the controlling user of the indicated message;
- optionally, in the "messageld" parameter, a reference of the related message and an indication whether the message is added or removed; and
- optionally, in the "mode" parameter the applicable invocation mode.

When accepting the activation, the private network shall send a MWIActivate return result component to the public network using the procedures of subclause 8.3.2.1.3 of ETS 300 196-1 [2]. Further actions to be taken by the private network are outside the scope of the ETS.

When the public network receives a correctly encoded MWIActivate return result component, then the public network shall stop timer T-ACTIVATE, accept the provided information and the MWI supplementary service is successfully activated. Furthermore the public network shall continue clearing of the signalling connection according to subclause 8.3.2.1.3 of ETS 300 196-1 [2].

10.3.2 Exceptional procedures

If the private network is not able to activate the MWI supplementary service, the private network shall send a MWIActivate return error component to the public network within a Facility information element, using the procedure in subclause 8.3.2.1.3 of ETS 300 196-1 [2], indicating one of the following error values:

- "notAvailable", if the MWI supplementary service is not available for the indicated basic service;
- "invalidReceivingUserNr", if the ISDN number provided to identify the receiving user is not a valid number;
- "supplementaryServiceInteractionNotAllowed", if the provision of the MWI supplementary service is precluded by a procedure within EN 300 195-1 [1], clause 5;
- "resourceUnavailable", if the resources required to perform adequately the MWI supplementary service are not available;
- "invalidServedUserNr", if the ISDN number provided to identify the controlling user is not a valid number;

- "receivingUserNotSubscribed", if the MWI supplementary service has not been subscribed to by the receiving user;
- "controllingUserNotRegistered", if the controlling user is not allowed to activate the MWI supplementary service for the receiving user; or
- "indicationNotDelivered", if the controlling user's network has not received a response from the receiving user's network.

On receipt of a MWIActivate return error component, the public network shall stop T-ACTIVATE, forward the information to the controlling user and shall continue clearing of the signalling connection according to subclause 8.3.2.1.3 of ETS 300 196-1 [2].

On expiration of timer T-ACTIVATE and the public network not having received any response to the MWIActivate invoke component, the result of the activation request is undetermined and the public network shall initiate clearing of the signalling connection according to the procedures of subclause 8.3.2.1.3 of ETS 300 196-1 [2].

If a reject component is received by the private or public network and the invoke identifier is included, the reject component shall be ignored.

10.4 Deactivation of the message waiting indication where the receiving user resides in a private ISDN

10.4.1 Normal procedures

When the public network is informed that the controlling user requests deactivation of the MWI supplementary service, the public network shall send a MWIDeactivate invoke component to the private network and start timer T-DEACTIVATE using the procedures described in subclause 8.3.2.1.1 of ETS 300 196-1 [2].

The public network shall indicate:

- in the "controllingUserNr" parameter, the ISDN number of the controlling user from which the MWI service deactivation is requested;
- in the "basicService" parameter, the basic service to which the deactivation of the MWI supplementary service activation applies;
- in the "receivingUserNr" parameter, the ISDN number of the receiving user for which the deactivation applies; and
- if provided by the controlling user, in the "mode" parameter the applicable invocation mode.

When accepting the deactivation, the private network shall send a MWIDeactivate return result component to the public network using the procedures of subclause 8.3.2.1.3 of ETS 300 196-1 [2].

When the public network receives a correctly encoded MWIDeactivate return result component, then the public network shall stop timer T-DEACTIVATE, accept the provided information and the MWI supplementary service is successfully deactivated. Furthermore, the public network shall continue call clearing of the signalling connection according to subclause 8.3.2.1.3 of ETS 300 196-1 [2].

10.4.2 Exceptional procedures

If the private network is unable to deactivate the MWI supplementary service, the private network shall send a MWIDeactivate return error component to the public network within a Facility information element, using the procedure described in subclause 8.3.2.1.3 of ETS 300 196-1 [2], indicating one of the following error values:

- "invalidReceivingUserNr", if the ISDN number provided to identify the receiving user is not a valid number;
- "supplementaryServiceInteractionNotAllowed", if the provision of the MWI supplementary service is precluded by a procedure within EN 300 195-1 [1], clause 5;
- "resourceUnavailable", if the resources required to perform adequately the MWI supplementary service are not available. This error shall be used to indicate a congestion situation;
- "invalidServedUserNr", if the ISDN number provided to identify the controlling user is not a valid number;
- "receivingUserNotSubscribed", if the MWI supplementary service has not been subscribed to by the receiving user;
- "controllingUserNotRegistered", if the controlling user is not allowed to deactivate the MWI supplementary service for the receiving user;
- "indicationNotDelivered", if the controlling user's network has not received a response from the receiving user's network.

On receipt of a MWIDeactivate return error component, the public network shall stop T-DEACTIVATE, forward the information to the controlling user and shall continue clearing of the signalling connection according to subclause 8.3.2.1.3 of ETS 300 196-1 [2].

On expiration of timer T-DEACTIVATE and the public network not having received any response to the MWIDeactivate invoke component, the result of the deactivation request is undetermined and the public network shall initiate clearing of the signalling connection according to the procedures of subclause 8.3.2.1.3 of ETS 300 196-1 [2].

If a reject component is received by the private or public network and the invoke identifier is included, the reject component shall be ignored.

11 Interaction with other networks

No impact.

12 Interaction with other supplementary services

The interaction of the MWI supplementary service with other supplementary services shall be as specified in EN 300 195-1 [1].

13 Parameter values (timers)

The following values of the timers shall be used by this application when using the procedures of clause 10 in this ETS and subclause 10.2 of ETS 300 196-1 [2]:

- | | |
|--------------|--|
| T-ACTIVATE | The duration of the timer shall be 10 seconds. |
| T-DEACTIVATE | The duration of the timer shall be 10 seconds. |

14 Dynamic description (SDL diagrams)

The dynamic description shown in figures 1 to 8 is according to CCITT Recommendation Z.100 [11].

14.1 Controlling user

14.1.1 Controlling user - user side

14.1.1.1 Controlling user - user side (coincident S and T reference point)

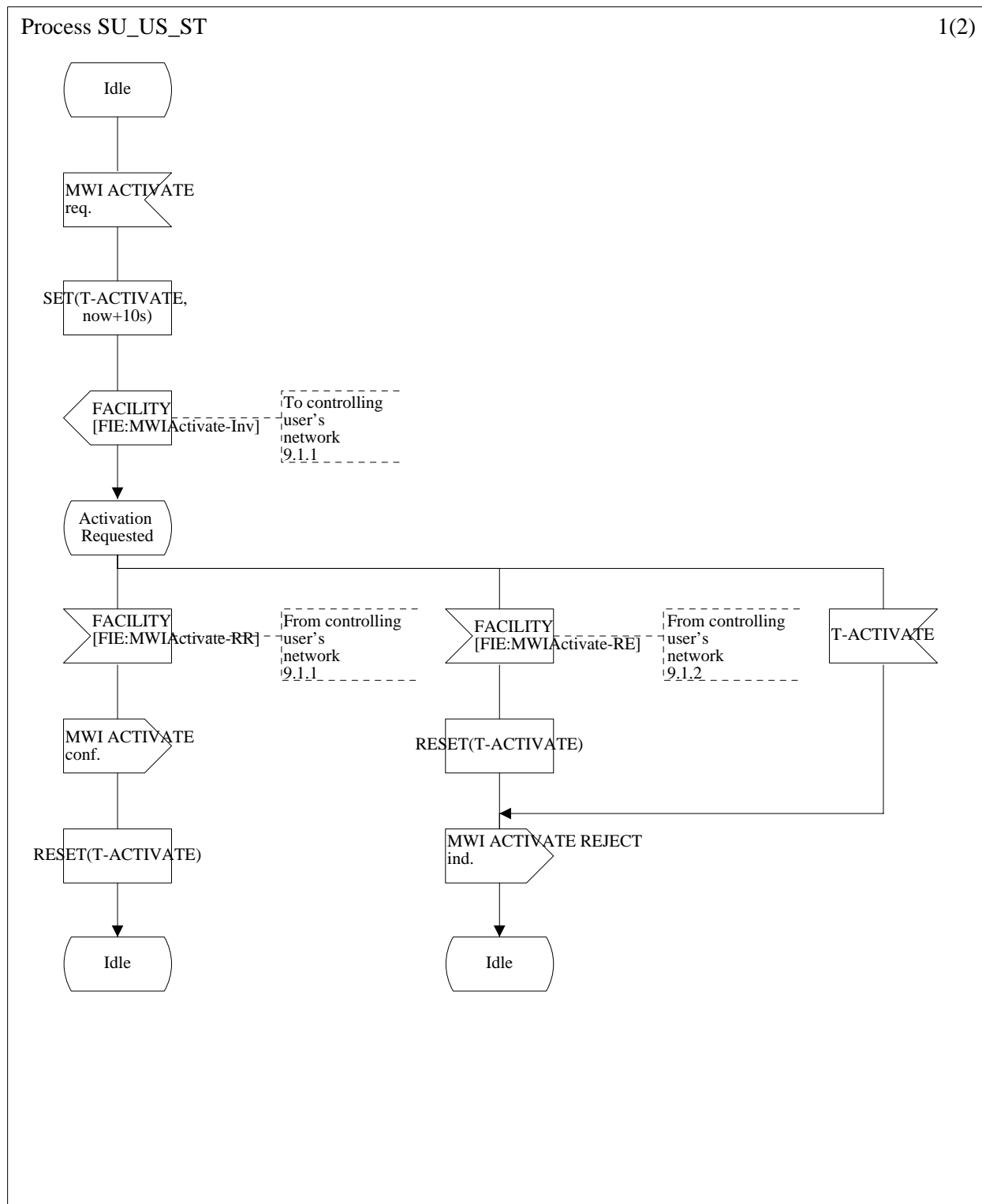

Figure 1 (sheet 1 of 2): Process SU-US-ST

Process SU_US_ST

2(2)

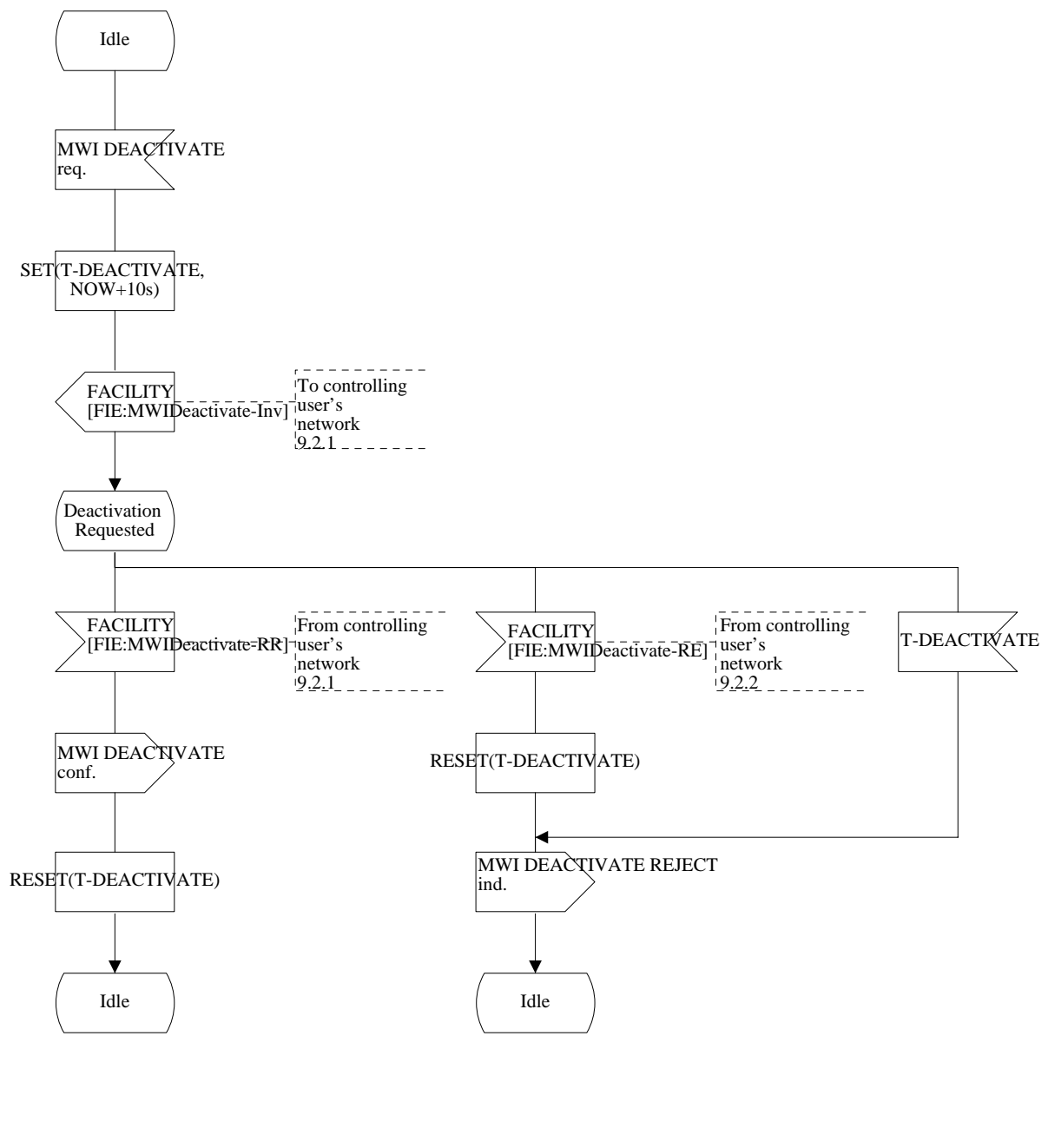

Figure 1 (sheet 2 of 2): Process SU-US-ST

14.1.1.2 Controlling user - user side (T reference point)

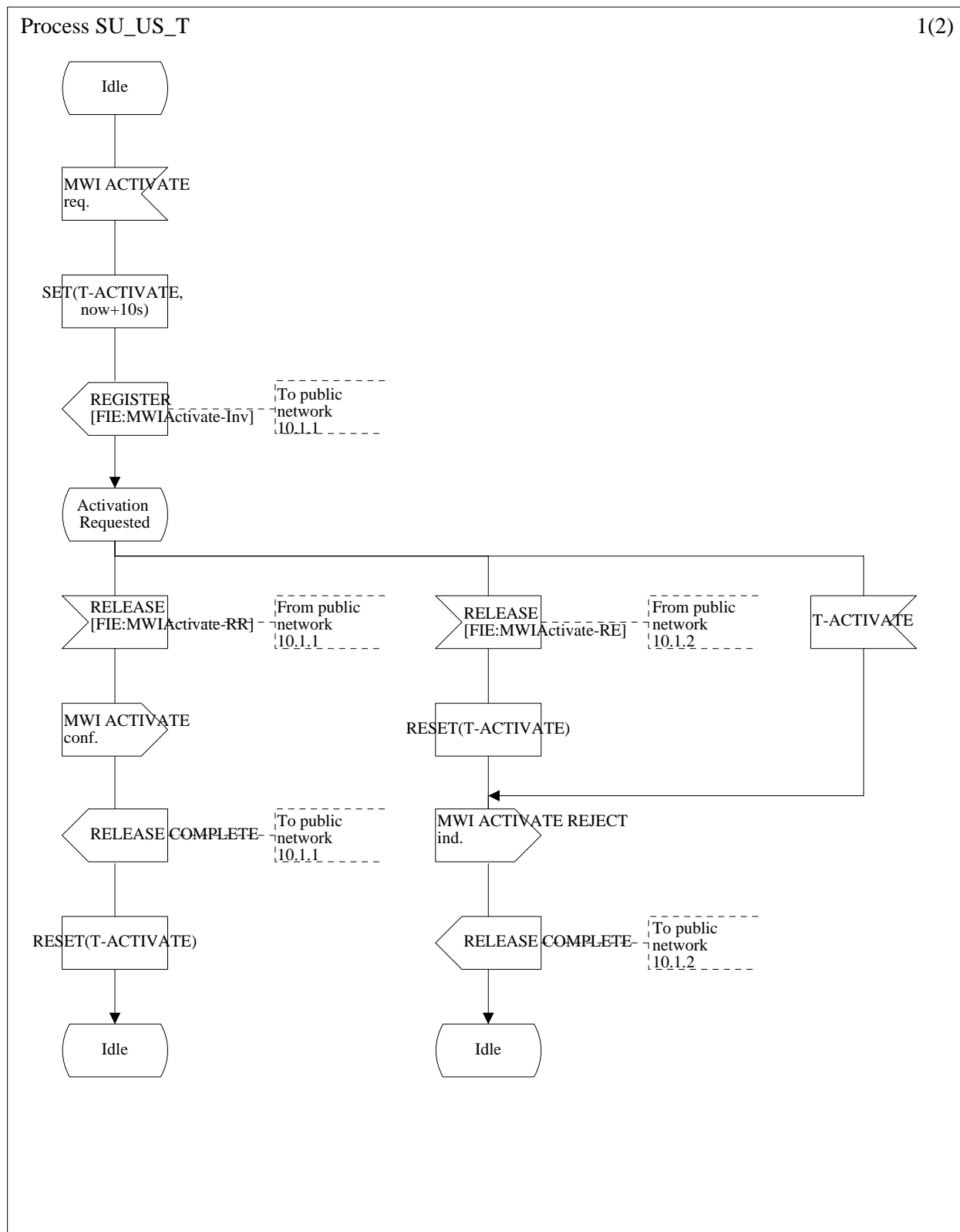

Figure 2 (sheet 1 of 2): Process SU-US-T

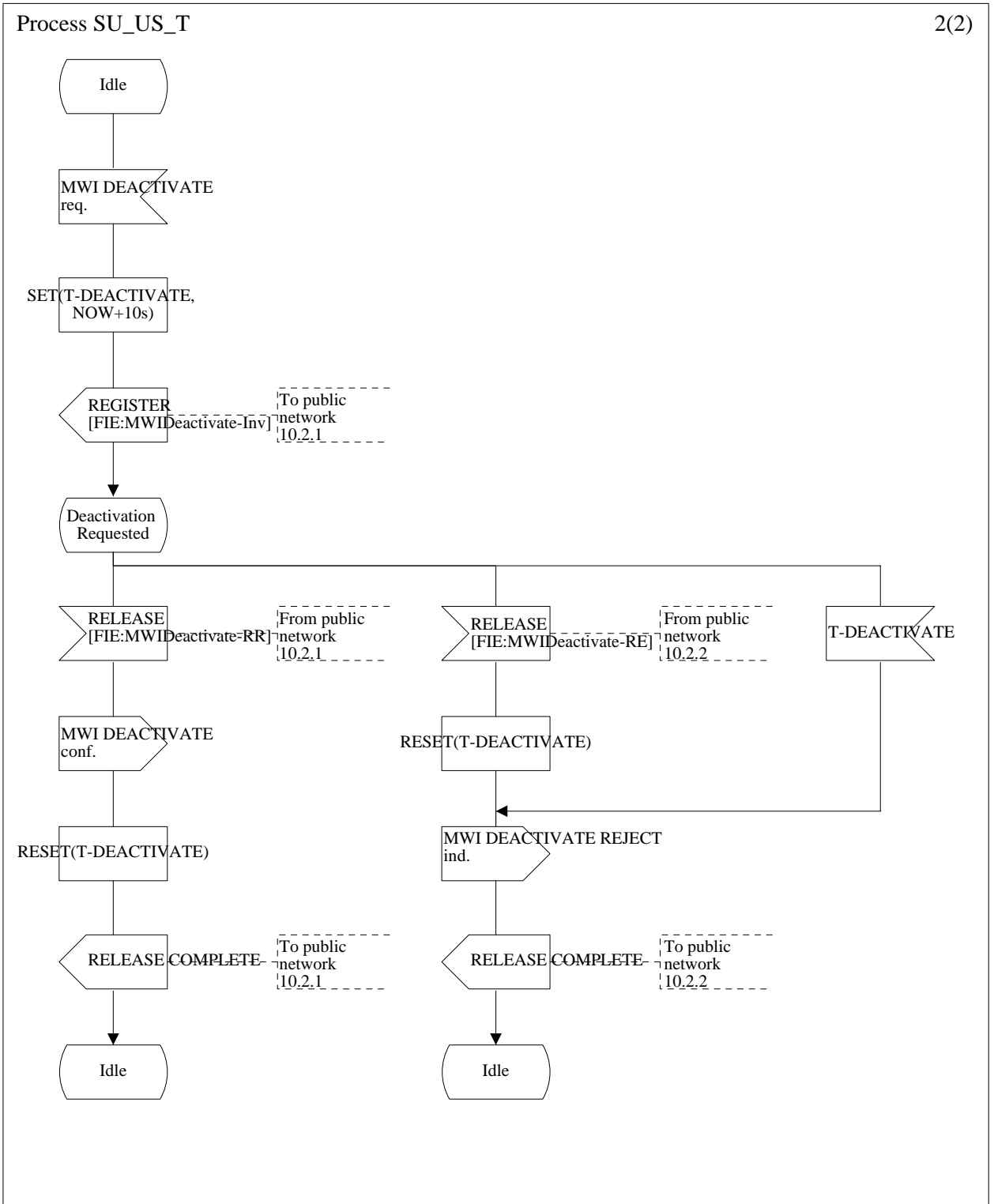

Figure 2 (sheet 2 of 2): Process SU-US-T

14.1.2 Controlling user - network side

14.1.2.1 Controlling user - network side (coincident S and T reference point)

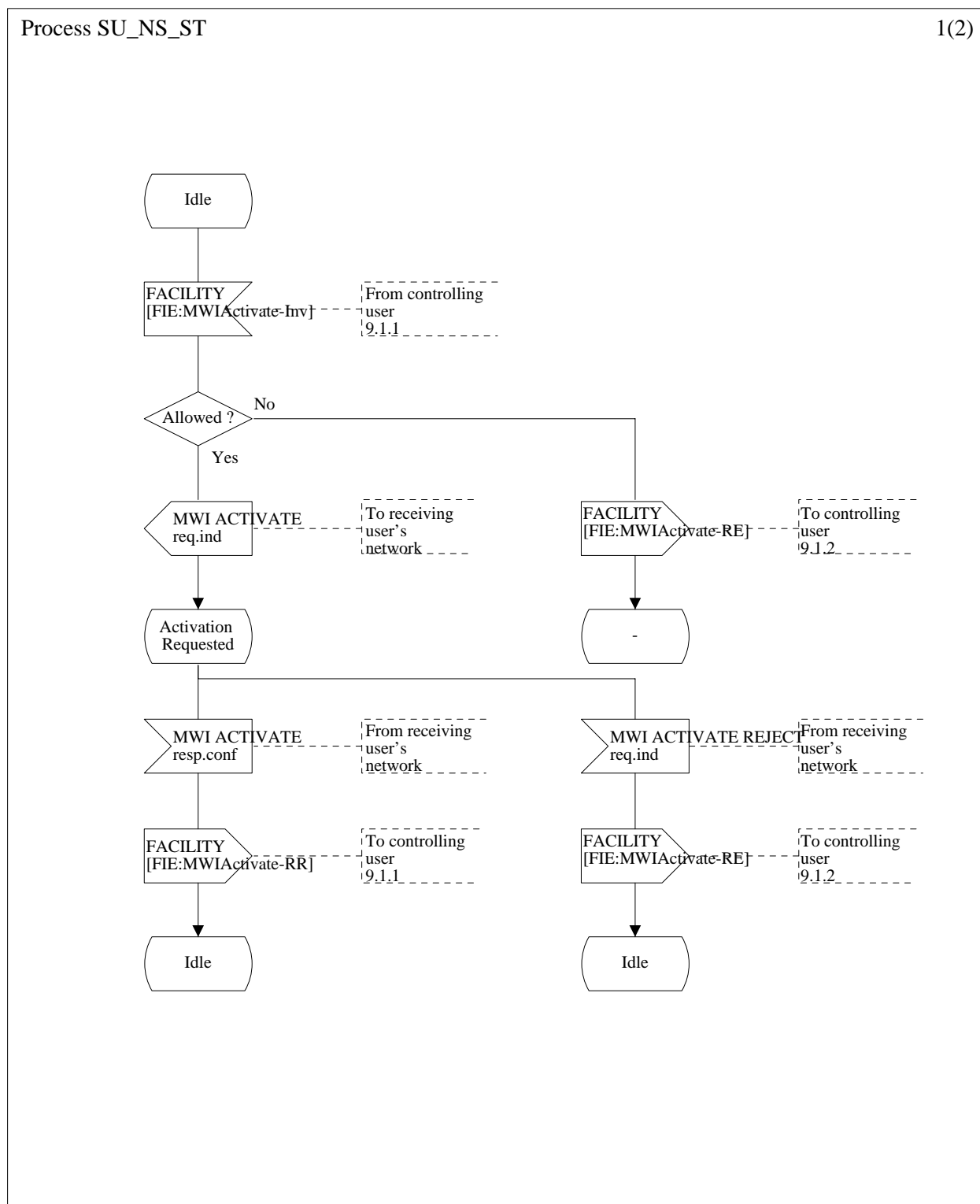

Figure 3 (sheet 1 of 2): Process SU-NS-ST

Process SU_NS_ST

2(2)

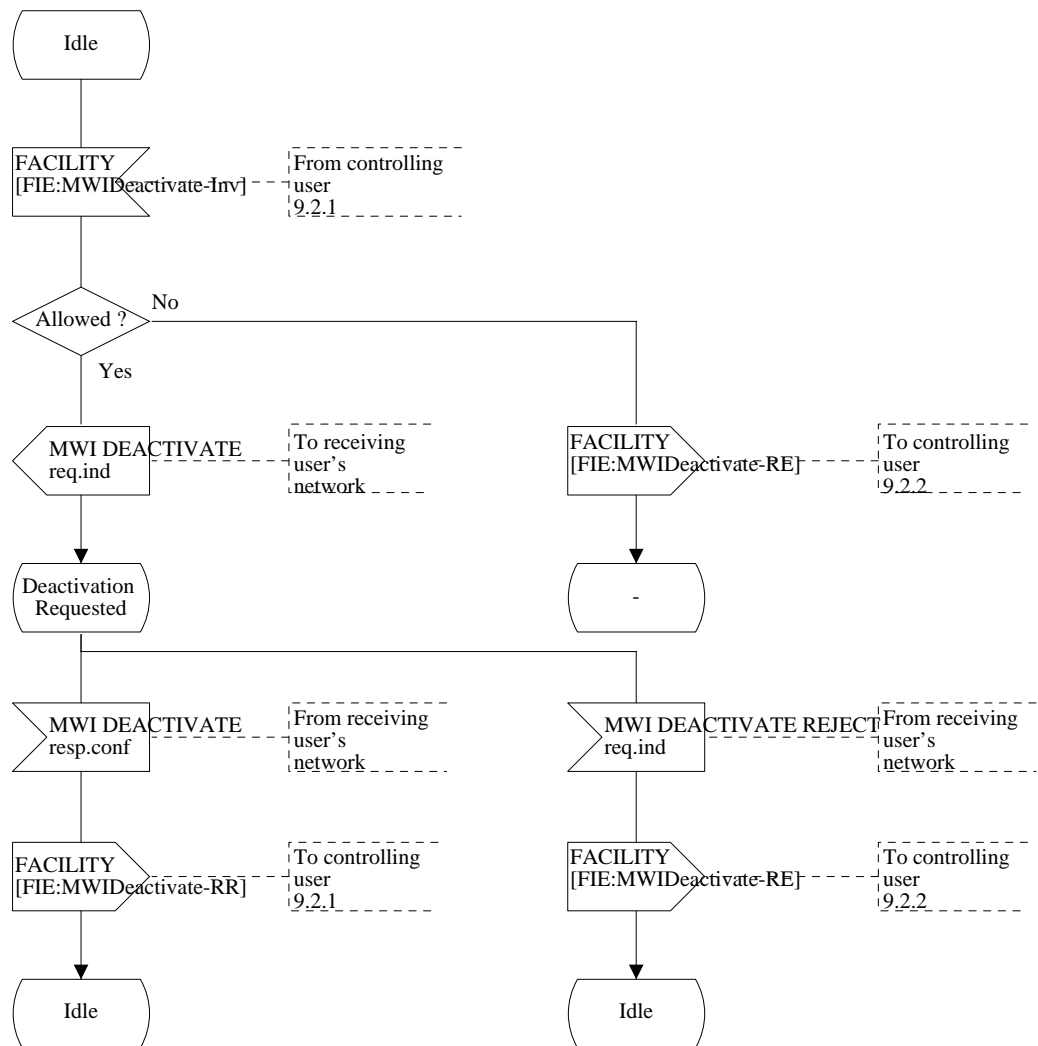

Figure 3 (sheet 2 of 2): Process SU-NS-ST

14.1.2.2 Controlling user - network side (T reference point)

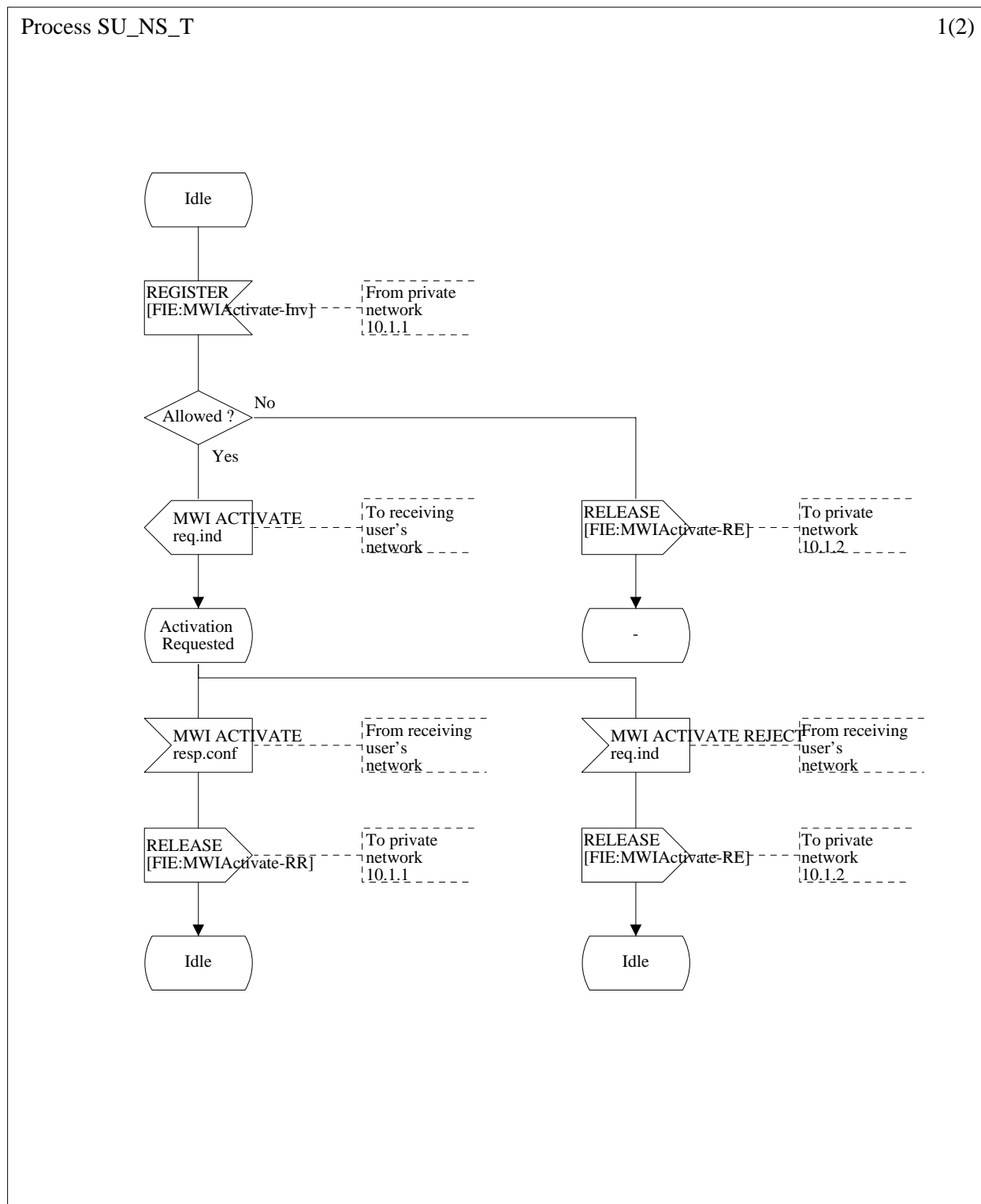

Figure 4 (sheet 1 of 2): Process SU-NS-T

Process SU_NS_T

2(2)

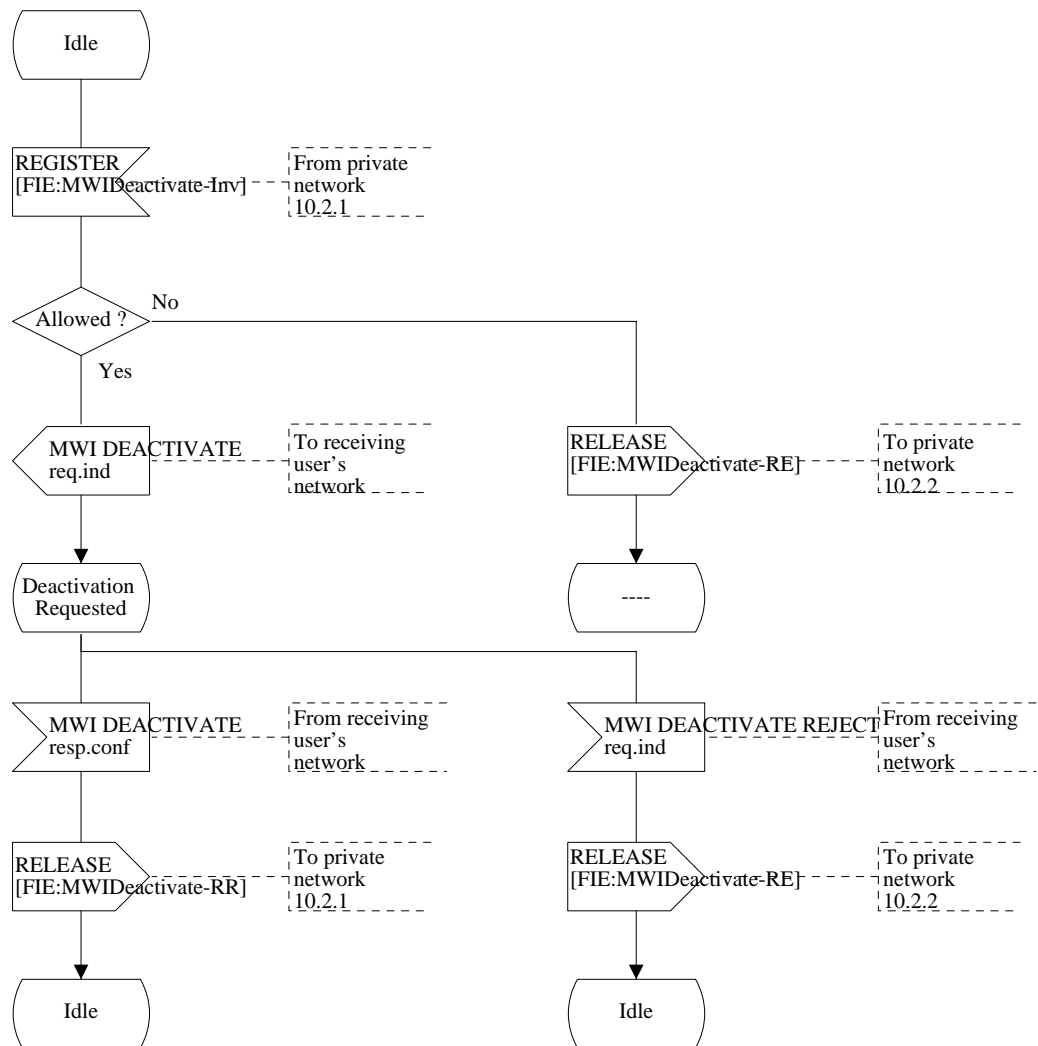

Figure 4 (sheet 2 of 2): Process SU-NS-T

14.2 Receiving user

14.2.1 Receiving user - user side

14.2.1.1 Receiving user - user side (coincident S and T reference point)

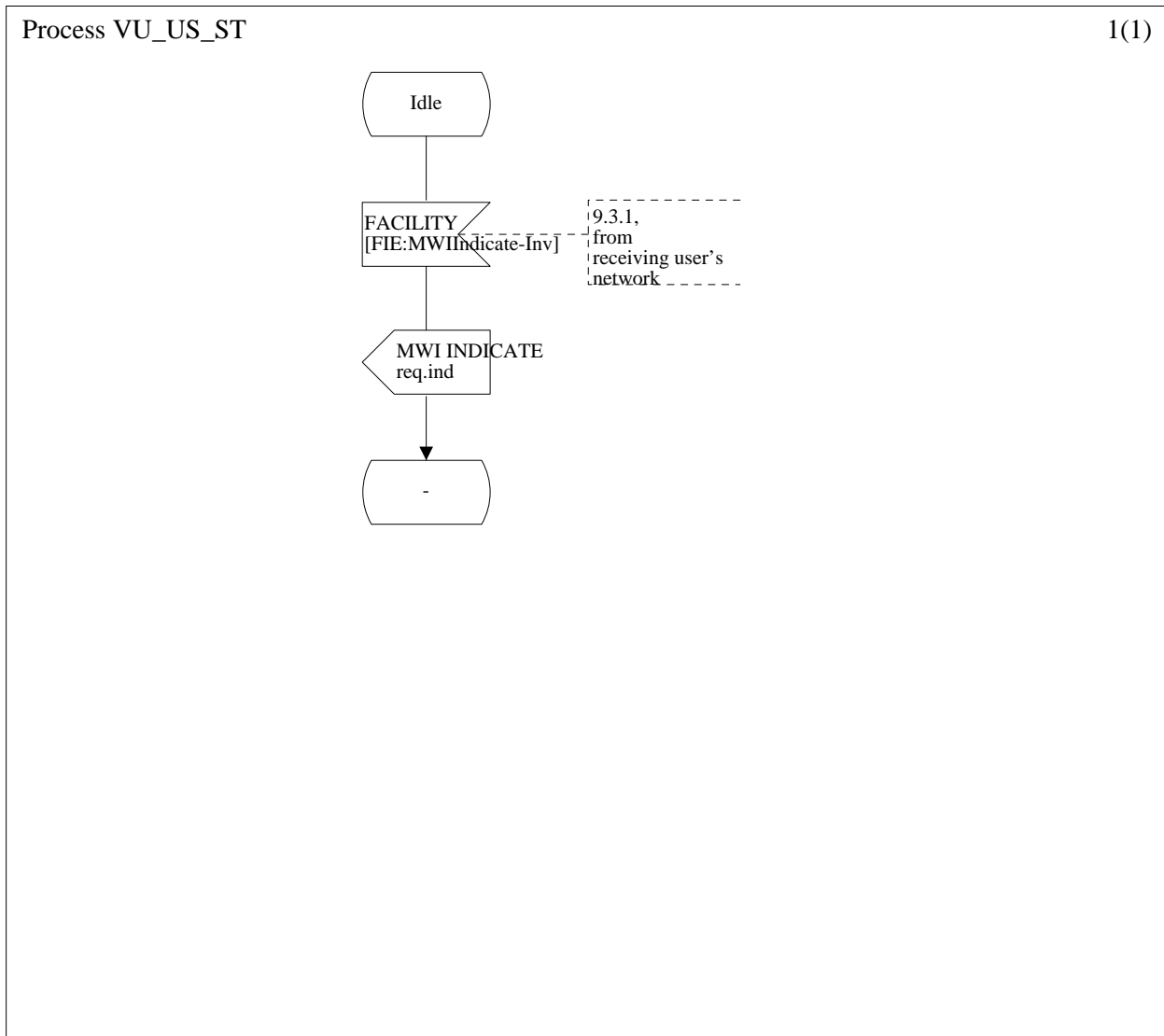

Figure 5: Process VU-US-ST

14.2.1.2 Receiving user - user side (T reference point)

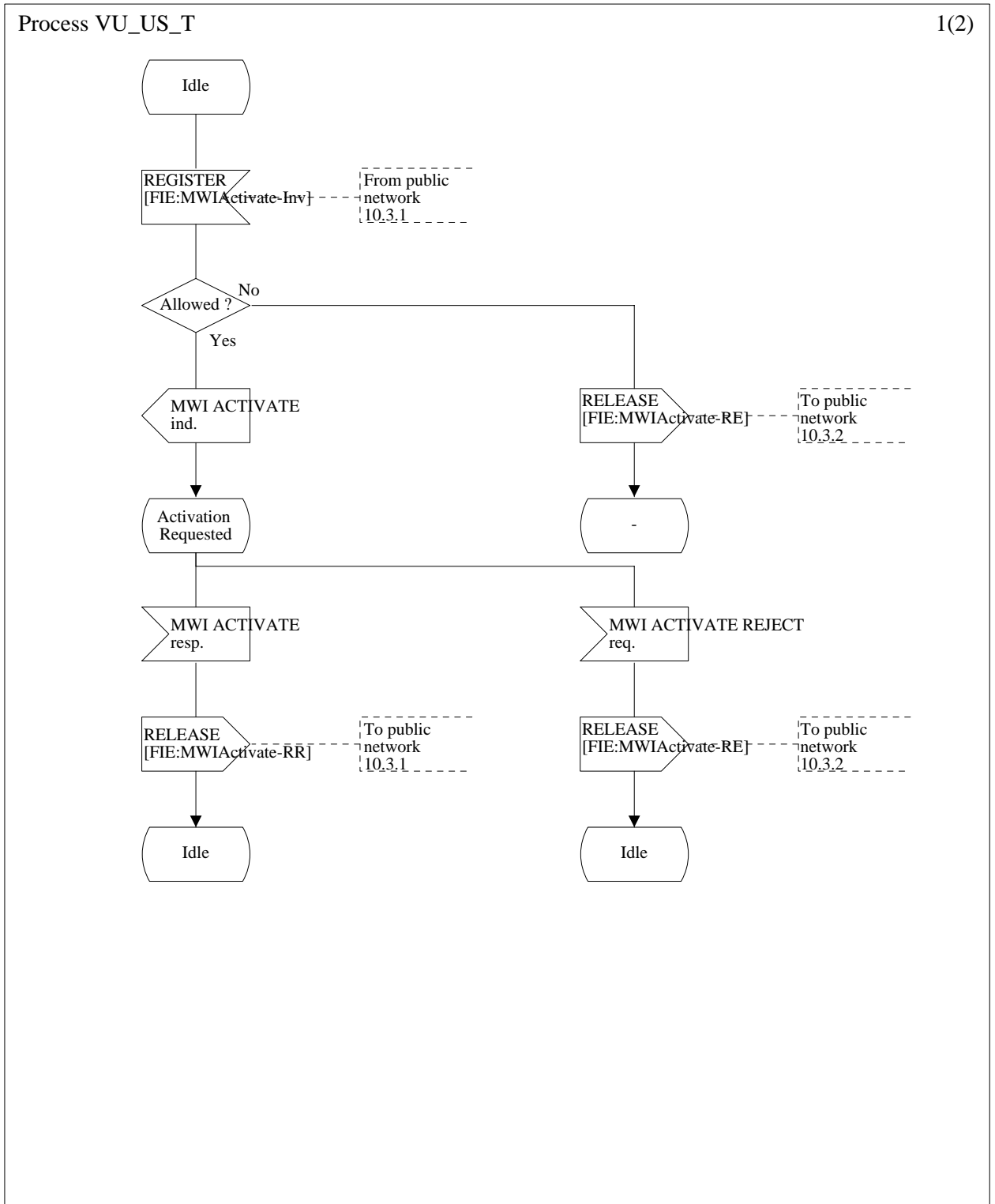

Figure 6 (sheet 1 of 2): Process VU-US-T

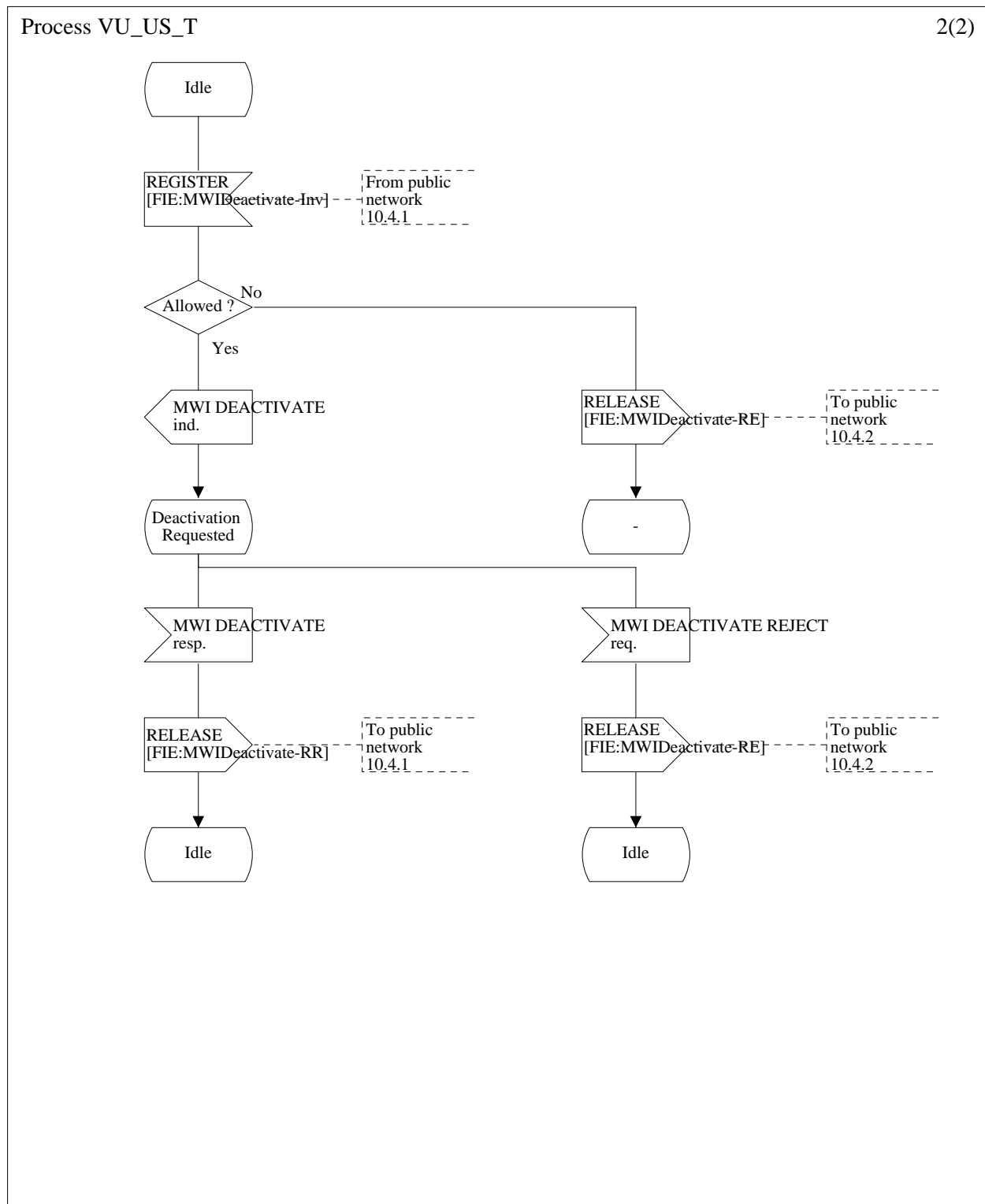

Figure 6 (sheet 2 of 2): Process VU-US-T

14.2.2 Receiving user - network side

14.2.2.1 Receiving user - network side (coincident S and T reference point)

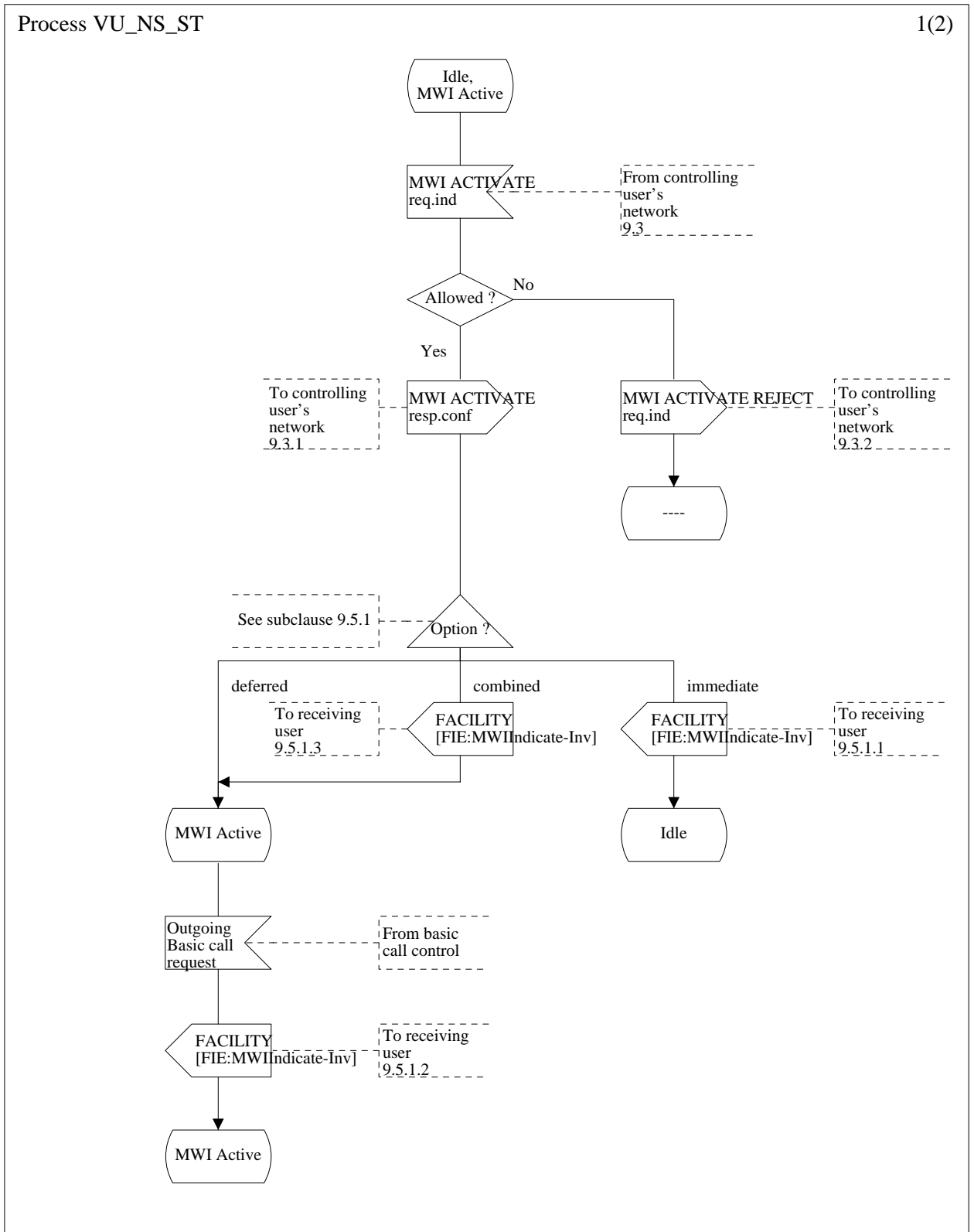

Figure 7 (sheet 1 of 2): Process VU-NS-ST

Process VU_NS_ST

2(2)

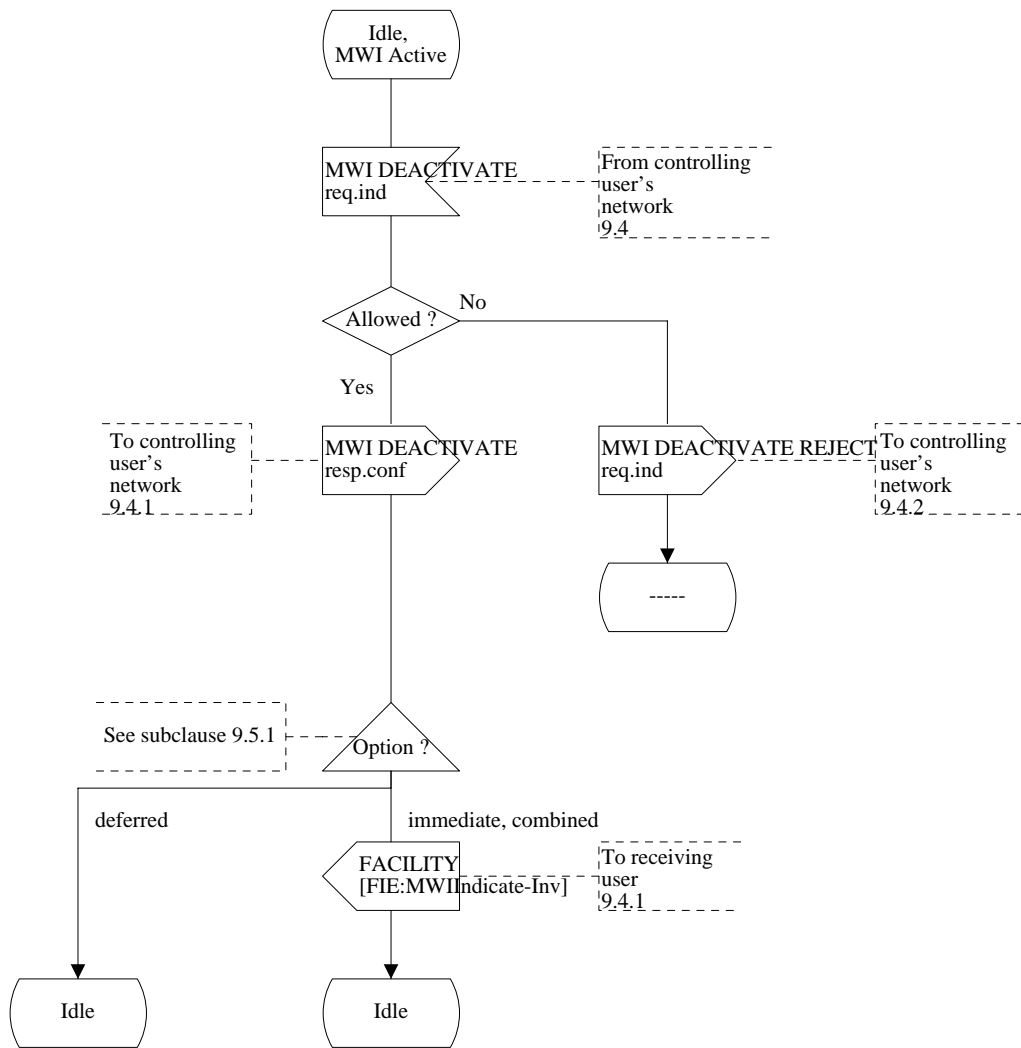

Figure 7 (sheet 2 of 2): Process VU-NS-ST

14.2.2.2 Receiving user - network side (T reference point)

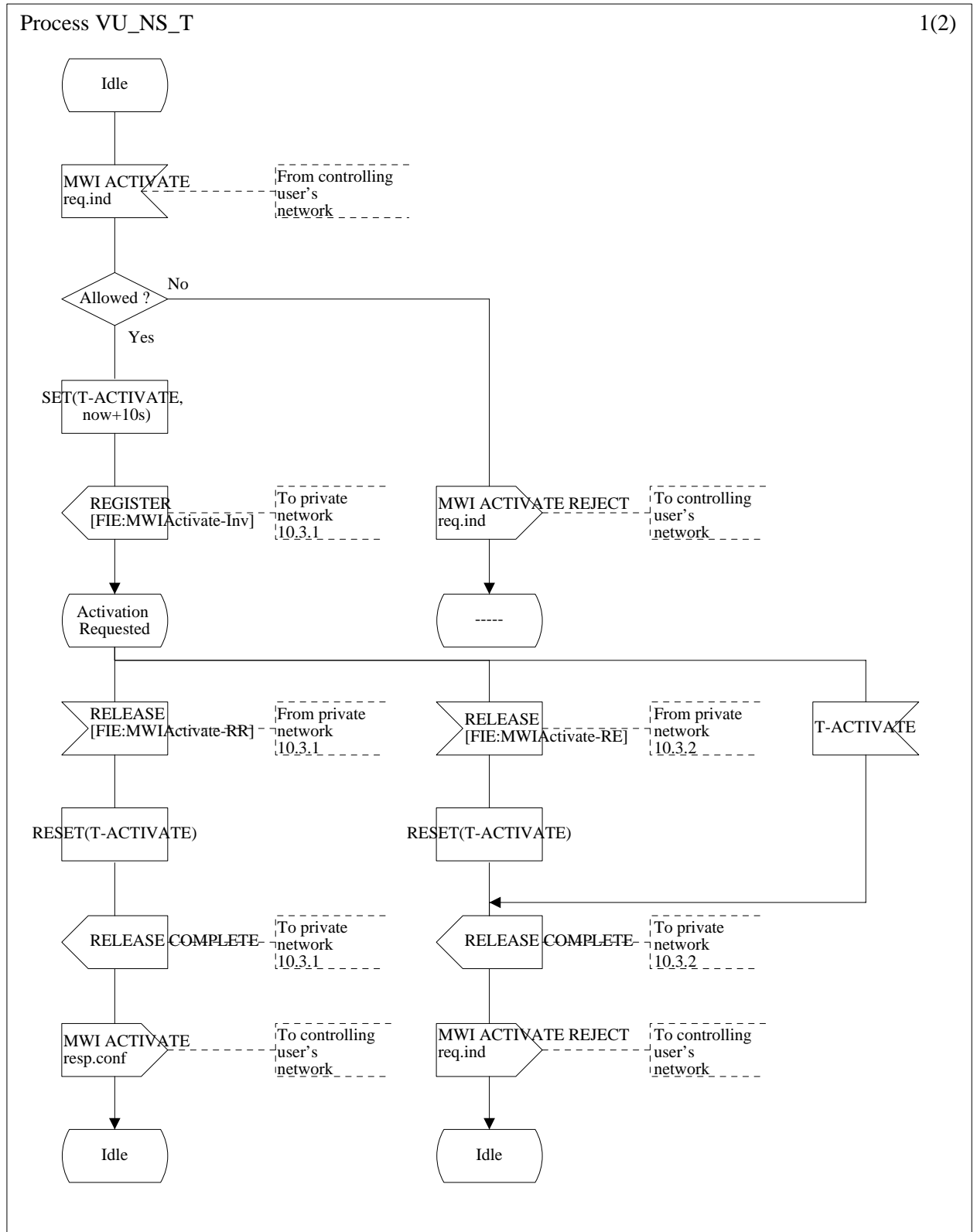

Figure 8 (sheet 1 of 2): Process VU-NS-T

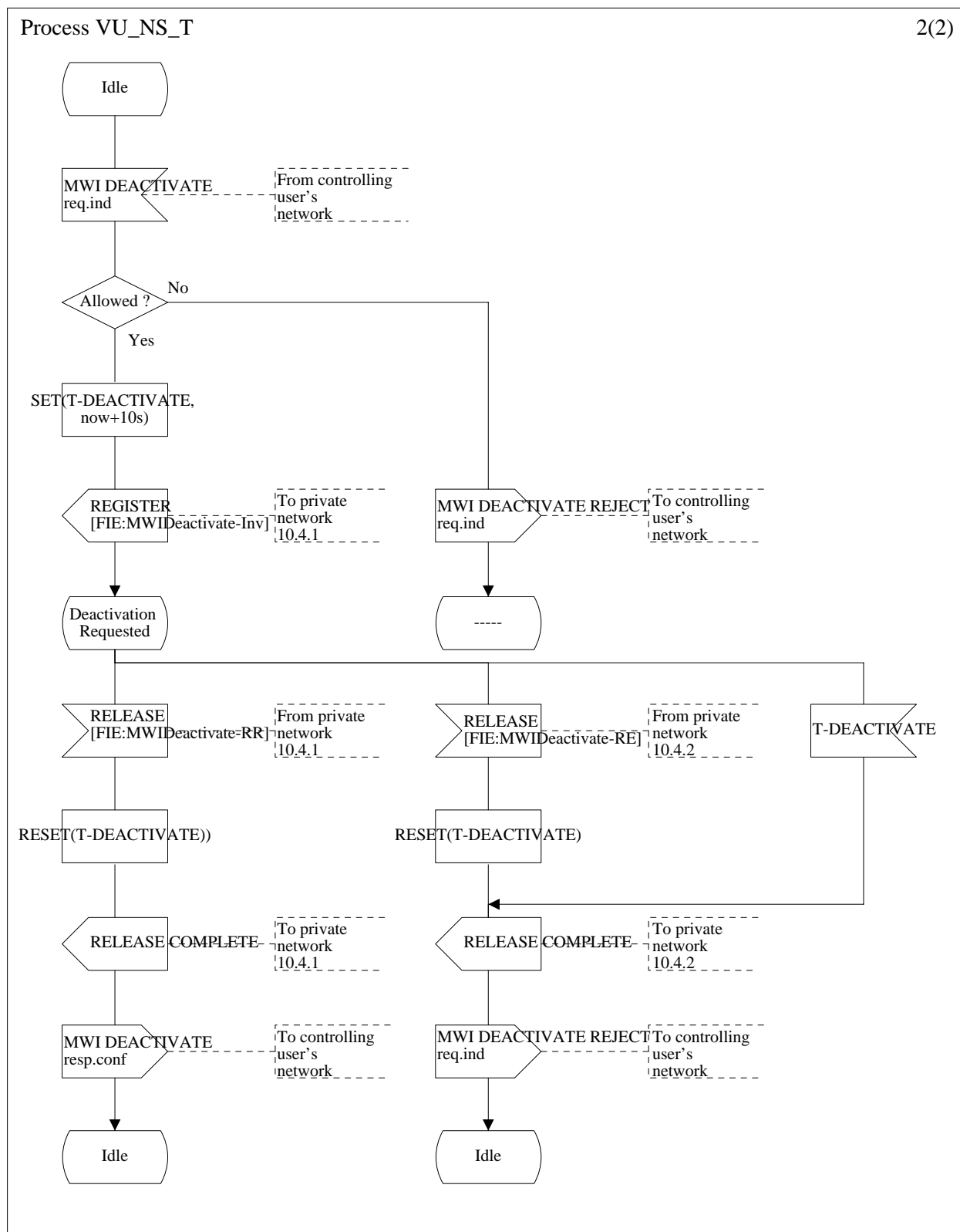

Figure 8 (sheet 2 of 2): Process VU-NS-T

Annex A (informative): Signalling flows

Figures A.1 to A.4 show the signalling flows for the MWI supplementary service.

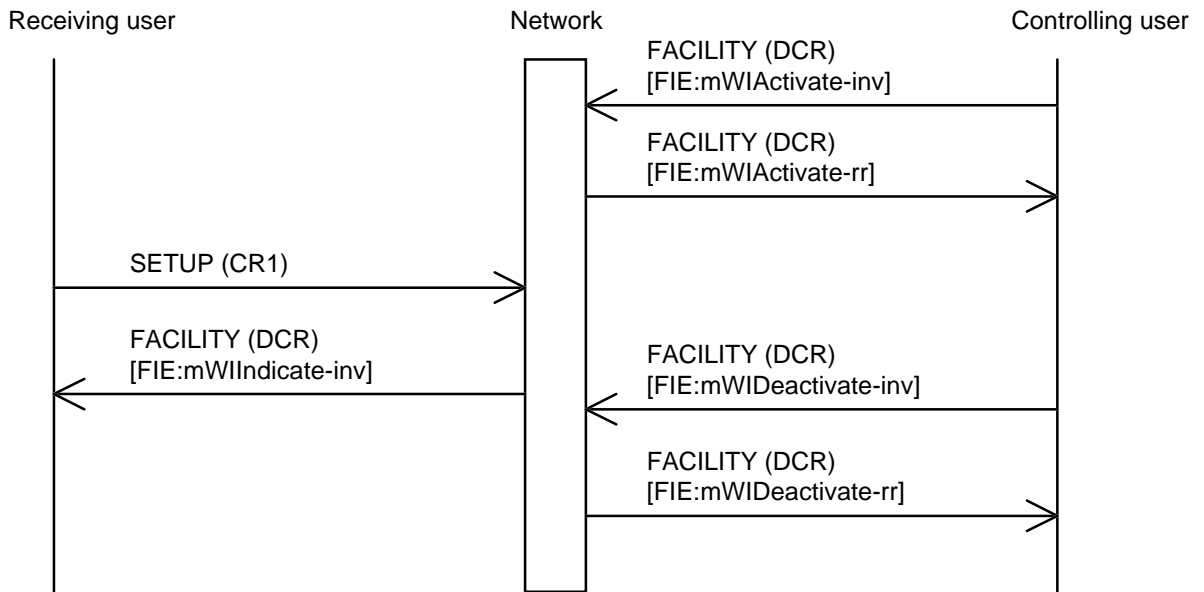

Figure A.1: Activation and deactivation of the MWI supplementary service in case of the receiving user in the same public network as the controlling user (deferred mode)

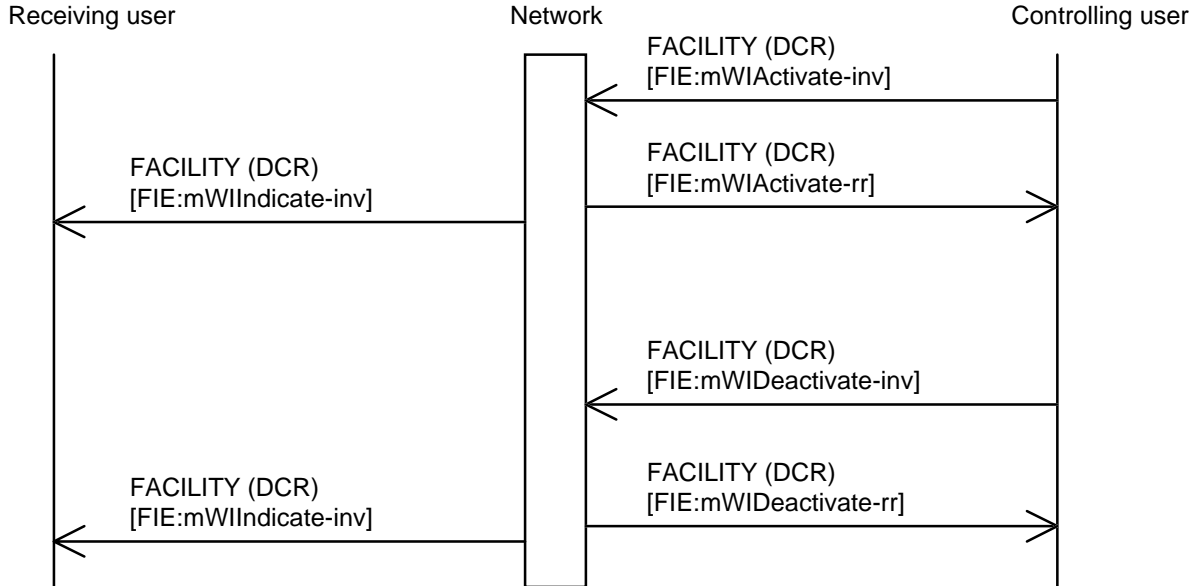

Figure A.2: Activation and deactivation of the MWI supplementary service in case of the receiving user in the same public network as the controlling user (immediate mode)

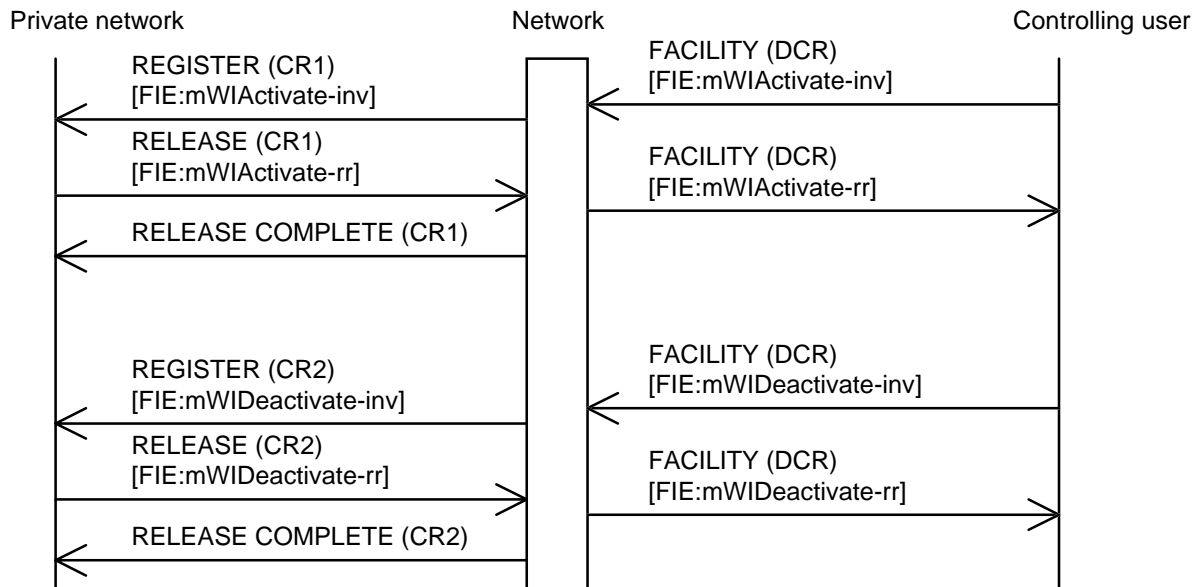

Figure A.3: Activation and deactivation of the MWI supplementary service in case of the receiving user in a private network

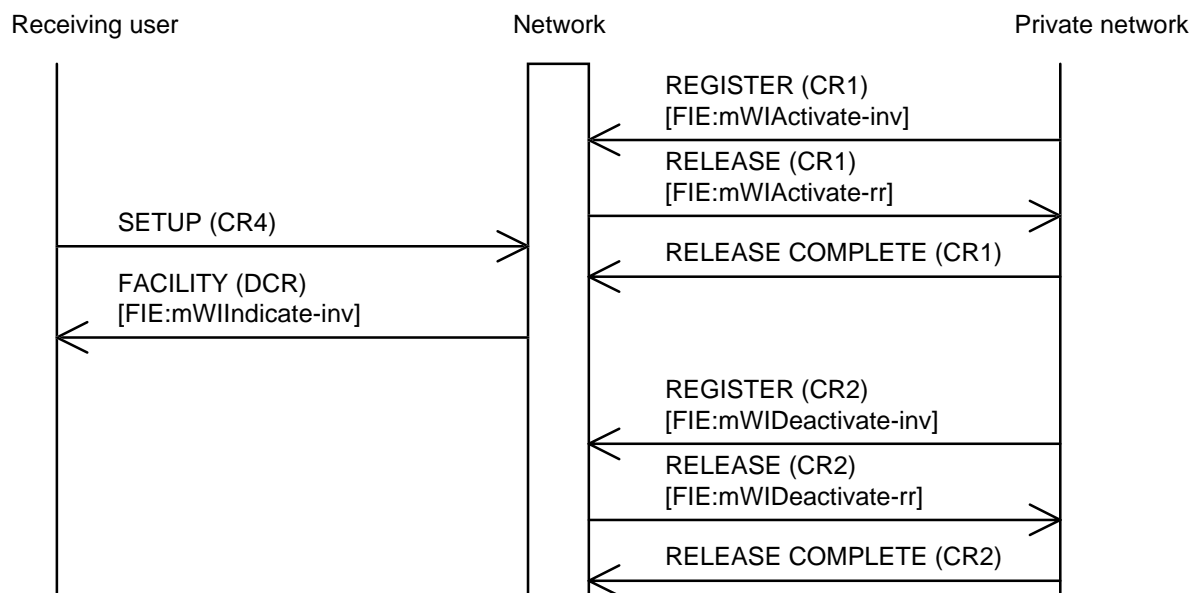

Figure A.4: Activation and deactivation of the MWI supplementary service in case of the controlling user in a private network and the deferred mode applies

Annex B (informative): Assignment of object identifier values

The following object identifier values are assigned in this ETS:

{ccitt identified-organization etsi(0) 745 operations-and-errors(1)}

{ccitt identified-organization etsi(0) 745 operations-and-errors(1) 1}

{ccitt identified-organization etsi(0) 745 operations-and-errors(1) 2}

{ccitt identified-organization etsi(0) 745 operations-and-errors(1) 3}

{ccitt identified-organization etsi(0) 745 operations-and-errors(1) 10}

{ccitt identified-organization etsi(0) 745 operations-and-errors(1) 11}

{ccitt identified-organization etsi(0) 745 operations-and-errors(1) 12}

{ccitt identified-organization etsi(0) 745 operations-and-errors(1) 13}

{ccitt identified-organization etsi(0) 745 operations-and-errors(1) 14}

{ccitt identified-organization etsi(0) 745 operations-and-errors(1) 15}

History

Document history			
May 1996	Public Enquiry	PE 106:	1996-05-20 to 1996-09-13
April 1997	Vote	V 9724:	1997-04-15 to 1997-06-13
July 1997	First Edition		