



**E**UROPEAN  
**T**ELECOMMUNICATION  
**S**TANDARD

**ETS 300 742**

April 1997

---

Source: ETSI TC-TM

Reference: DE/TM-03064

ICS: 33.020

**Key words:** Broadband, ISDN, access, interface, UNI, ATM

**Transmission and Multiplexing (TM);  
Physical layer User Network Interface (UNI)  
for 2 048 kbit/s Asynchronous Transfer Mode (ATM) signals**

**ETSI**

European Telecommunications Standards Institute

**ETSI Secretariat**

**Postal address:** F-06921 Sophia Antipolis CEDEX - FRANCE

**Office address:** 650 Route des Lucioles - Sophia Antipolis - Valbonne - FRANCE

**X.400:** c=fr, a=atlas, p=etsi, s=secretariat - **Internet:** secretariat@etsi.fr

Tel.: +33 4 92 94 42 00 - Fax: +33 4 93 65 47 16

---

**Copyright Notification:** No part may be reproduced except as authorized by written permission. The copyright and the foregoing restriction extend to reproduction in all media.

© European Telecommunications Standards Institute 1997. All rights reserved.



## Contents

Foreword .....	5
1 Scope .....	7
2 Normative references .....	7
3 Definitions and abbreviations .....	8
3.1 Definitions .....	8
3.2 Abbreviations .....	8
4 Reference configuration at the user-network interface .....	9
4.1 Functional groups and reference points .....	9
4.2 Examples of physical realizations .....	10
4.3 Basic characteristics of the interfaces at $T_B$ and $S_B$ reference points for 2 048 kbit/s .....	14
4.3.1 Interface at $T_B$ reference point .....	14
4.3.2 Interface at the $S_B$ reference point .....	14
4.3.3 Relationship between interfaces at $S_B$ and $T_B$ .....	14
4.4 Relationship between ISDN interfaces .....	14
4.5 Functional groups characteristics .....	14
4.5.1 Network termination 1 for B-ISDN (B-NT1) .....	14
4.5.2 Network termination 2 for B-ISDN (B-NT2) .....	14
4.5.3 Terminal equipment for B-ISDN (B-TE) .....	15
4.5.3.1 Terminal equipment type 1 for B-ISDN (B-TE1) .....	15
4.5.3.2 Terminal equipment type 2 for B-ISDN (B-TE2) .....	15
4.5.4 Terminal adapter for B-ISDN (B-TA) .....	15
5 UNI specifications .....	15
5.1 Interface location with respect to reference configuration .....	15
5.2 Interface location with respect to the wiring configuration .....	15
6 Service and layering aspects of the physical layer .....	16
6.1 Services provided to the ATM-layer .....	16
6.2 Service primitives exchanged with the ATM layer .....	16
6.3 Sublayering of the physical layer .....	16
7 Physical medium characteristics at the $T_B$ and $S_B$ reference point of the UNI for 2 048 kbit/s .....	16
7.1 Bit rate and interface symmetry .....	16
7.2 Physical characteristics .....	17
7.2.1 Electrical interface .....	17
7.2.1.1 Interface range .....	17
7.2.1.2 Transmission medium .....	17
7.2.1.3 Electrical parameters at interface points $I_a$ and $I_b$ .....	17
7.2.1.4 Electrical connectors .....	17
7.2.1.5 Line coding .....	18
7.2.1.6 Electromagnetic compatibility and electromagnetic interference requirements .....	18
7.2.1.7 Jitter and Wander .....	18
8 Power feeding .....	18
8.1 Provision of power .....	18
8.2 Power available at B-NT1 .....	18
8.3 Feeding voltage .....	18
8.4 Safety requirements .....	19
9 Functions provided by the transmission convergence sublayer .....	19
9.1 Transfer capability for 2 048 kbit/s .....	19

9.2	Physical Layer aspects.....	19
9.2.1	Timing .....	19
9.2.2	Interface structure for 2 048 kbit/s .....	19
9.3	Header error control .....	21
9.3.1	Header error control functions .....	21
9.3.2	Header error control sequence generation .....	23
9.4	Idle cells .....	23
9.5	Cell delineation and scrambling .....	23
9.5.1	Cell delineation and scrambling objectives .....	23
9.5.2	Cell delineation algorithm .....	24
9.5.3	Cell delineation performance .....	25
9.5.4	Scrambler operation .....	25
10	UNI related OAM and operational functions .....	25
10.1	Operational functions .....	25
10.1.1	Definition of signals.....	25
10.1.2	Definitions of state tables at network and user sides .....	27
10.1.2.1	Layer 1 states on the user side of the interface .....	27
10.1.2.2	Layer 1 states at the network side of the interface .....	28
10.1.2.3	Definition of primitives.....	29
10.1.2.4	State tables .....	30
Annex A (informative):	Bibliography .....	35
History .....		36

## Foreword

This European Telecommunication Standard (ETS) defines the user network access physical layer interface to be applied to the  $T_B$ ,  $S_B$  reference points of the reference configurations of the B-ISDN User Network Interface (UNI) for Broadband Integrated Services Digital Network (B-ISDN) applications. It addresses the structure of the transmission system that is used at these interfaces as well as the implementation of the UNI related Operation Administration and Maintenance (OAM) functions at the physical layer.

This ETS has been produced by the Transmission and Multiplexing Technical Committee of the European Telecommunications Standards Institute (ETSI) taking into account the recommendations given in ITU-T Recommendations I.413 [7] and I.432 [8].

<b>Transposition dates</b>	
Date of adoption:	4 April 1997
Date of latest announcement of this ETS (doa):	31 July 1997
Date of latest publication of new National Standard or endorsement of this ETS (dop/e):	31 January 1998
Date of withdrawal of any conflicting National Standard (dow):	31 January 1998

Blank page

## 1 Scope

This European Telecommunication Standard (ETS) defines the physical layer interface to be applied to the  $S_B$  and  $T_B$  reference points of the reference configurations of the Broadband Integrated Services Digital Network (B-ISDN) User Network Interface (UNI) at 2 048 kbit/s. It addresses separately the physical media and the transmission system used at these interfaces and addresses also the implementation of UNI related Operation Administration and Maintenance (OAM) functions.

The physical medium for the interfaces at the  $S_B$  and  $T_B$  reference points should take into account that only electrical wires are to be used to cable customer equipment.

This ETS mainly is based on ETS 300 300 [13], being responsible for the bit rates 155 520 kbit/s and 622 080 kbit/s and the ITU-T Recommendation I.432 [8] being responsible for the bit rates 622 080 kbit/s, 155 520 kbit/s, 2 048 kbit/s and 1 544 kbit/s.

## 2 Normative references

This ETS incorporates by dated or undated reference, provisions from other publications. These normative references are cited at the appropriate places in the text and the publications are listed hereafter. For dated references, subsequent amendments to or revisions of any of these publications apply to this ETS only when incorporated in it by amendment or revision. For undated references the latest edition of the publication referred to applies.

- [1] ITU-T Recommendation G.804: "ATM cell mapping into Plesiochronous Digital Hierarchy (PDH)".
- [2] ETS 300 166 (1993): "Transmission and Multiplexing (TM); Physical and electrical characteristics of hierarchical digital interfaces for equipment using the 2048 kbit/s - based plesiochronous or synchronous digital hierarchies".
- [3] ITU-T Recommendation I.431: "Primary rate user-network interface - Layer 1 specification".
- [4] ITU-T Recommendation G.823 (1993): "The control of jitter and wander within digital networks which are based on the 2 048 kbit/s hierarchy".
- [5] ITU-T Recommendation I.113 (1993): "Vocabulary of terms for broadband aspects of ISDN".
- [6] ITU-T Recommendation I.361 (1993): "B-ISDN ATM Layer specification".
- [7] ITU-T Recommendation I.413 (1993): "B-ISDN user-network interface".
- [8] ITU-T Recommendation I.432.1 (1995): "B-ISDN user-network interface - Physical Layer specification, General Characteristics".  
ITU-T Recommendation I.432.3 (1995): "B-ISDN user-network interface - Physical Layer specification for 2 048 kbit/s".
- [9] ITU-T Recommendation I.610 (1993): "B-ISDN operation and maintenance principles and functions".
- [10] ITU-T Recommendation X.200: "Information technology - Open Systems Interconnection - Basic reference model: The basic model".
- [11] IEC 950: "Safety of information technology equipment, including electrical business equipment".
- [12] ITU-T Recommendation I.321 (1991): "B-ISDN protocol reference model and its application".

- [13] ETS 300 300 (1997): "Broadband Integrated Services Digital Network (B-ISDN); Synchronous Digital Hierarchy (SDH) based user network access; Physical layer User Network Interfaces (UNI) for 155 520 kbit/s and 622 080 kbit/s Asynchronous Transfer Mode (ATM) B-ISDN applications".
- [14] ITU-T Recommendation I.604: "Application of maintenance principles to ISDN primary rate access".
- [15] ITU-T Recommendation G.706: "Frame alignment and cyclic redundancy check (CRC) procedures relating to basic frame structures defined in Recommendation G.704".
- [16] ITU-T Recommendation G.704: "Synchronous frame structures at primary and secondary hierarchical levels".
- [17] ITU-T Recommendation G.732: "Characteristics of primary PCM multiplex equipment operating at 2 048 kbit/s".
- [18] ITU-T Recommendation G.775: "Loss of signal (LOS) and alarm indication signal (AIS) defect detection and clearance criteria".

### 3 Definitions and abbreviations

#### 3.1 Definitions

For the purposes of this ETS, the definitions given in ITU-T Recommendation I.113 [5] apply, specially for idle cell, valid cell and invalid cell.

**to be defined:** These items or values are not yet specified.

**for further study:** These items are required for further study.

#### 3.2 Abbreviations

For the purposes of this ETS, the following abbreviations apply:

AIS	Alarm Indication Signal
ATM	Asynchronous Transfer Mode
B-ISDN	Broadband Integrated Services Digital Network
B-NT	Broadband Network Termination
B-TA	Broadband Terminal Adapter
B-TE	Broadband Terminal Equipment
B-UNI	Broadband-User Network Interface
BER	Bit Error Rate
CATV	CABle TeleVision
CLP	Cell Loss Priority
CMI	Coded Mark Inversion
CRC	Cyclic Redundancy Check
EMC	Electro-Magnetic Compatibility
EMI	Electro-Magnetic Interference
FAW	Frame Alignment Word
HEC	Header Error Control
ISDN	Integrated Services Digital Network
LAN	Local Area Network
LCD	Loss of Cell Delineation
LOF	Loss Of Frame
LOS	Loss Of Signal
LSB	Least Significant Bit
MA	Medium Adapter
MPH	Management Physical Header
MSB	Most Significant Bit



NRZ	Non Return to Zero
OAM	Operation Administration and Maintenance
OCD	Out of Cell Delineation
OSI	Open Systems Interconnection
PDH	Plesiochronous Digital Hierarchy
ppm	parts per million
PH	Physical Header
PM	Physical Medium
RAI	Remote Alarm Indication
RDI	Remote Defect Indication
REI	Remote Error Indication
SDH	Synchronous Digital Hierarchy
SMF	Sub Multi Frame
STI	Surface Transfer Impedance
TC	Transmission Convergence
TFV	Terminal Failure Voltage
TS	Time Slot
UNI	User Network Interface
VC	Virtual Container
VP	Virtual Path

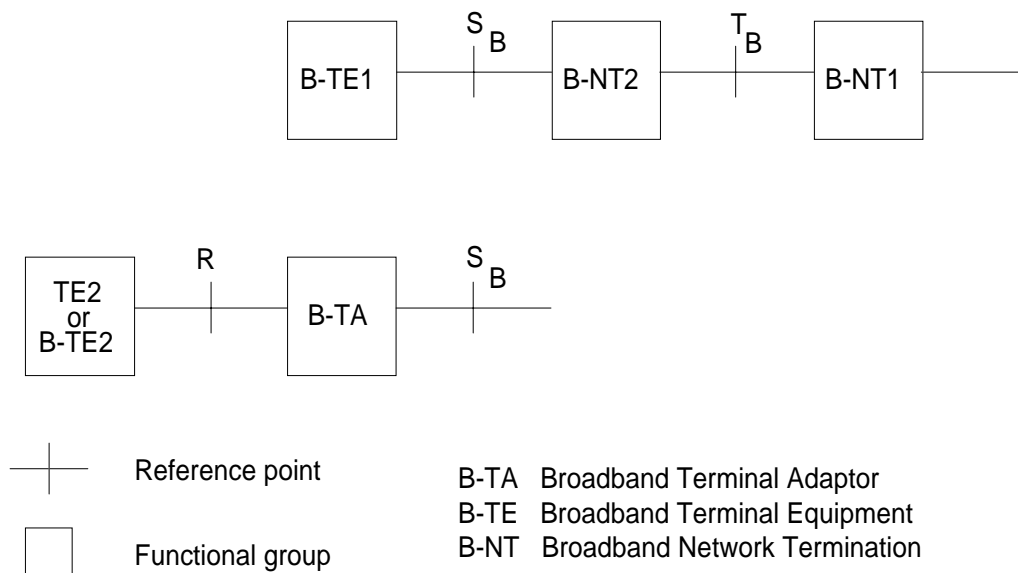
## 4 Reference configuration at the user-network interface

### 4.1 Functional groups and reference points

The reference configurations defined for ISDN basic access and primary access are considered general enough to be applicable to all aspects of the B-ISDN accesses.

Figure 1 shows the B-ISDN reference configurations which contain the following:

- functional groups: B-TE1; B-NT2; B-TE1; TE2; B-TE2; and B-TA;
- reference points:  $T_B$ ;  $S_B$  and R.



**Figure 1: B-ISDN reference configurations**

In order to clearly illustrate the broadband aspects, the notation for reference points and for functional groups with broadband capabilities are appended with the letter B (e.g. B-NT1,  $T_B$ ). The broadband functional groups are equivalent to the functional groups defined in ISDN. Interfaces at the R reference point may or may not have broadband capabilities.

Interfaces at reference points  $S_B$  and  $T_B$  will be standardized. These interfaces will support all ISDN services.

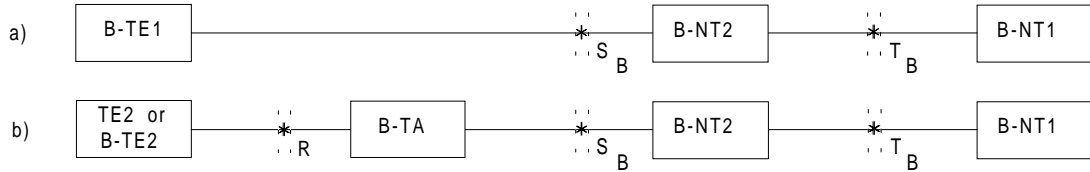
## 4.2 Examples of physical realizations

Figure 2 gives examples of physical configurations illustrating combinations of physical interfaces at various reference points. The examples cover configurations that could be supported by standardized interfaces at reference points  $S_B$  and  $T_B$ . Other configurations may also exist. For example, physical configurations of B-NT2 may be distributed or use shared medium to support Local Area Network (LAN) emulation and other applications.

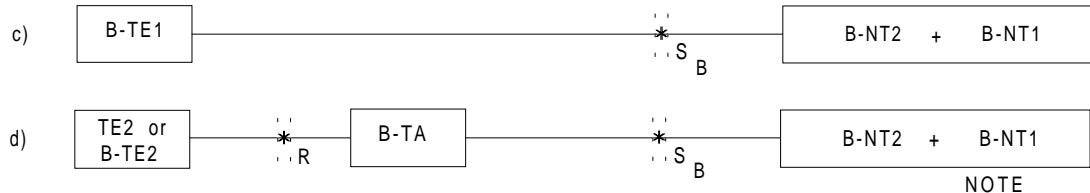
Figure 3 illustrates possible physical configurations, but does not preclude alternative configurations. Whether a single interface at the  $S_B$  reference point can cover different configurations, as illustrated in figure 3, is for further study.

Figures 2a and 2b show separate interfaces at the  $S_B$  and  $T_B$  reference points; figures 2c) and 2d) show an interface at  $S_B$  but not at  $T_B$ ; figures 2e and 2f show an interface at  $T_B$  but not at  $S_B$ ; figures 2g and 2h show separate interfaces at  $S$ ,  $S_B$  and  $T_B$ ; figures 2i and 2j show interfaces at  $S_B$  and  $T_B$  which are coincident.

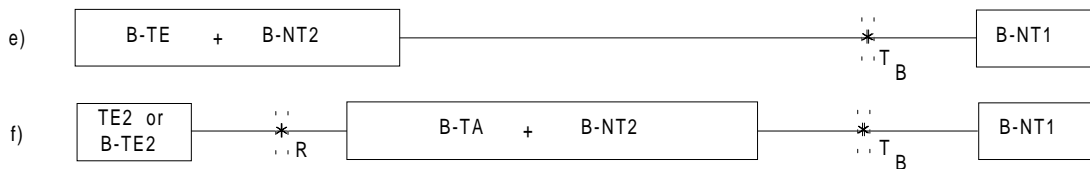
Additionally, figures 2b), 2d), 2f), 2h) and 2j) show an interface at reference point R.



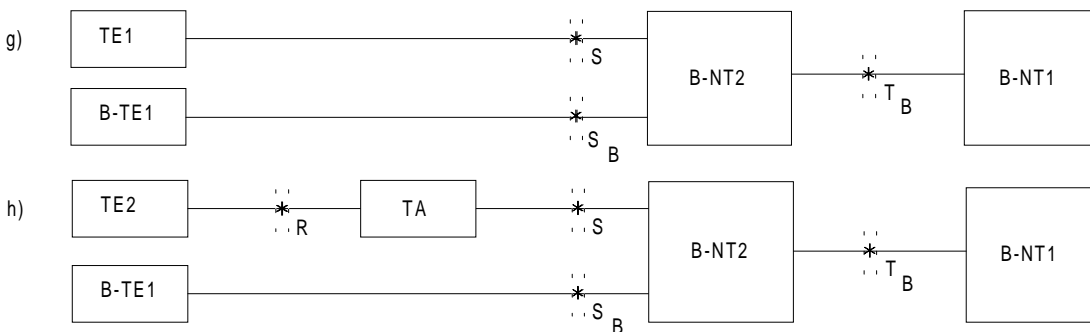
**Configurations where B-ISDN physical interfaces occur at reference points  $S_B$  and  $T_B$**



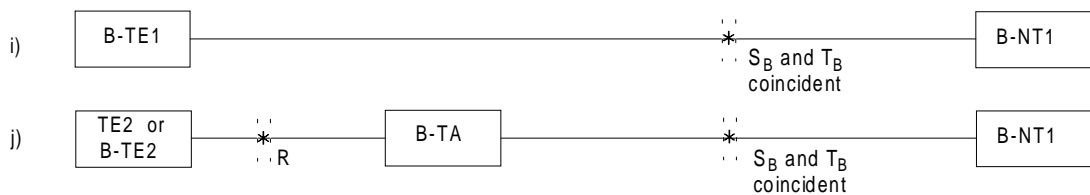
**Configurations where B-ISDN physical interfaces occur at reference point  $S_B$  only**



**Configurations where B-ISDN physical interfaces occur at reference point  $T_B$  only**



**Configurations where B-ISDN and ISDN physical interfaces occur at reference points S,  $S_B$  and  $T_B$**



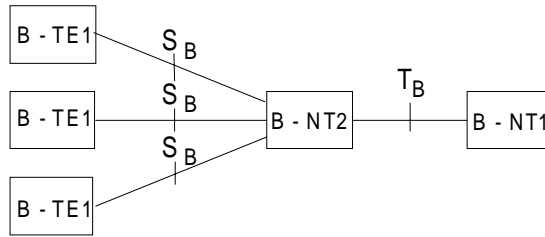
**Configurations where a single B-ISDN physical interface occurs at a location where both reference points  $S_B$  and  $T_B$  coincide**



NOTE: The need for an access to a TB-Reference point (between B-NT1 and B-NT2) is for further study.

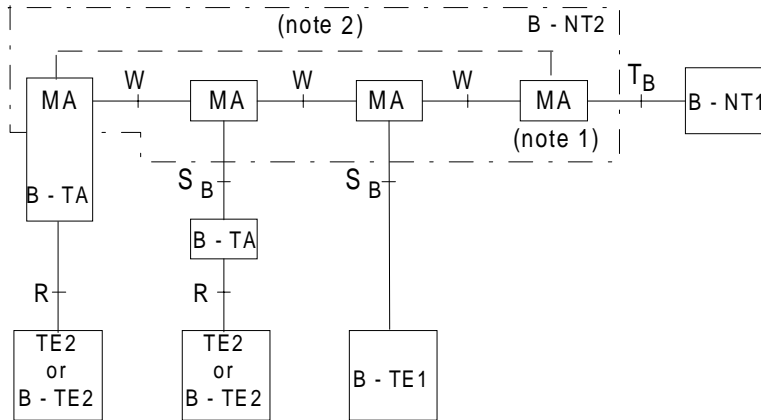
**Figure 2: Examples of physical configurations for broadband user applications**

a) centralized B-NT2 configuration

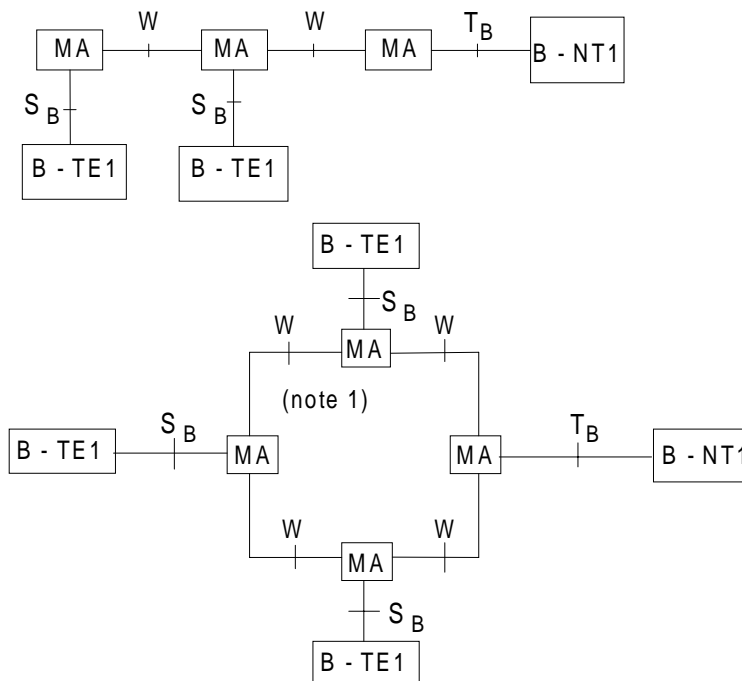


b) distributed B-NT2 configurations

b1) generic configuration

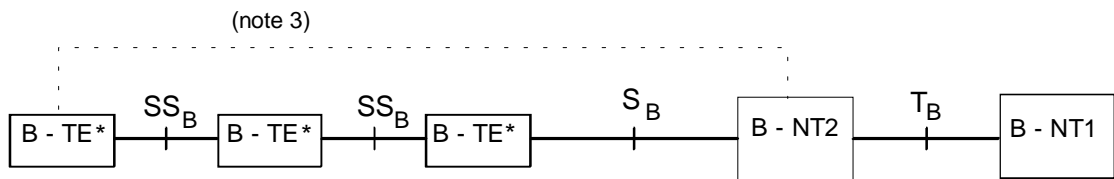


b2) physical configurations

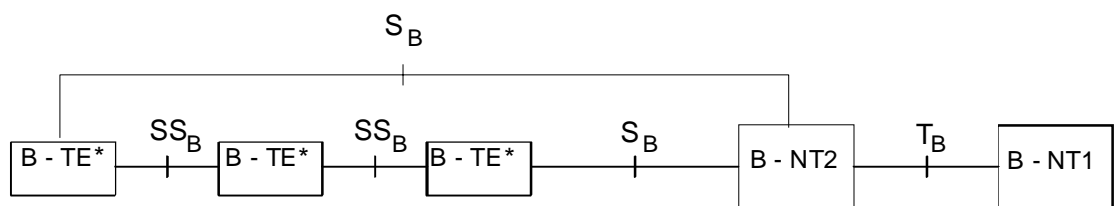
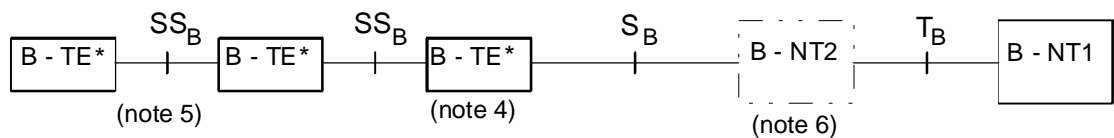
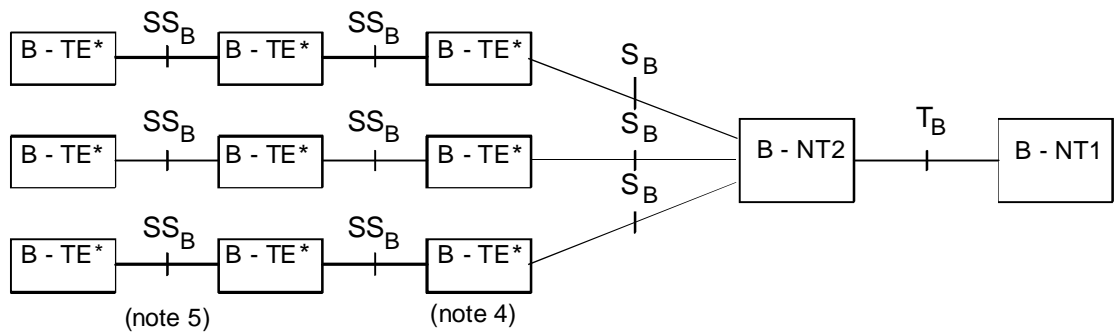


**c) multi-access B-TE configurations**

c1) generic configurations (note 7)



c2) physical configurations



- NOTE 1: MA: Medium Adapter; accommodates the specific topology of the distributed B-NT2. The interface at W may include topology dependant elements; it may be a non-standardized interface.
- NOTE 2: There will be a physical link between these two Medium Adapters in the case of ring configurations.
- NOTE 3: There will be a physical link between B-TE\* and B-NT2 in the case of ring configurations.
- NOTE 4: B-TE\* includes shared medium access functions.
- NOTE 5: The measurable physical characteristics of the  $SS_B$  interface are identical to those of the  $S_B$  interface. The functional characteristics of the interface, however, may be a superset of those at the  $S_B$  interface.
- NOTE 6: The B-NT2 may be null in the case of commonality between  $S_B$  and  $T_B$ .
- NOTE 7: Additional termination functions (e.g. for loopback in bus configuration) and OAM functions may be necessary for multi-access B-TE\* configurations. Requirements and implementations of these functions are for further study.

**Figure 3: Examples of physical configurations for multipoint applications**

### 4.3 Basic characteristics of the interfaces at $T_B$ and $S_B$ reference points for 2 048 kbit/s

#### 4.3.1 Interface at $T_B$ reference point

There is only one interface per B-NT1 at the  $T_B$  reference point. The operation of the physical medium is point-to-point in the sense that there is only one sink (receiver) in front of one source (transmitter).

Point-to-multipoint configurations at  $T_B$  at the ATM and higher layers are for further study.

#### 4.3.2 Interface at the $S_B$ reference point

One or more  $S_B$  interfaces per B-NT2 are present. The interface at the  $S_B$  reference point is point-to-point at the physical layer in the sense that there is only one sink (receiver) in front of one source (transmitter) and may be point to multipoint at the other layers.

#### 4.3.3 Relationship between interfaces at $S_B$ and $T_B$

Configurations described in figures 2i and 2j require that the interface specifications at  $T_B$  and  $S_B$  should have a high degree of commonalty, in order to ensure that a simple broadband terminal may be connected directly to the  $T_B$  interface.

### 4.4 Relationship between ISDN interfaces

Figures 2g and 2h show configurations where B-ISDN and ISDN interfaces may occur at  $S_B$  and S respectively. In this case B-NT2 functionalities have to ensure the interface capabilities for both S and  $S_B$ . Other configurations for supporting terminals at the interface at the S reference point may exist.

### 4.5 Functional groups characteristics

Lists of functions for each functional group are given below. Each particular function is not necessarily restricted to a single functional group. For example, "interface termination" functions are included in the function lists of B-NT1, B-NT2 and B-TE. The function lists for B-NT1, B-NT2, B-TE and B-TA are not exhaustive. Not all specific functions in a functional group need to be present in all implementations.

#### 4.5.1 Network termination 1 for B-ISDN (B-NT1)

This functional group includes functions broadly equivalent to layer 1 of the OSI reference model.

Examples of B-NT1 functions are:

- line transmission termination;
- transmission interface handling;
- OAM functions.

#### 4.5.2 Network termination 2 for B-ISDN (B-NT2)

This functional group includes functions broadly equivalent to layer 1 and higher layers of the ITU-T Recommendation X.200 [10] reference model. B-NT2 can be null in the case of commonalty between  $T_B$  and  $S_B$ .

Examples of B-NT2 functions are:

- adaptation functions for different media and topologies (MA functions);
- functions of a distributed B-NT2;
- cell delineation;
- concentration;
- buffering;
- multiplexing/demultiplexing;
- resource allocation;
- usage parameter control;
- adaptation layer functions for signalling (for internal traffic);
- interface handling (for the  $T_B$  and  $S_B$  interfaces);

- OAM functions;
- signalling protocol handling;
- switching of internal connections.

B-NT2 implementations may be concentrated or distributed. In a specific access arrangement, the B-NT2 may consist only of physical connections. When present, implementations of the B-NT2 are locally powered.

#### 4.5.3 Terminal equipment for B-ISDN (B-TE)

This functional group includes functions broadly belonging to layer 1 and higher layers of the ITU-T Recommendation X.200 [10] reference model.

Examples of B-TE functions are:

- user/user and user/machine dialogue and protocol;
- interface termination and other layer 1 functions;
- protocol handling for signalling;
- connection handling to other equipment;
- OAM functions.

The possibility of powering the B-TE via the  $S_B$  interface is for further study.

##### 4.5.3.1 Terminal equipment type 1 for B-ISDN (B-TE1)

This functional group includes functions belonging to the B-TE functional group with an interface that complies with the B-ISDN  $S_B$  and/or  $T_B$  interface recommendations.

##### 4.5.3.2 Terminal equipment type 2 for B-ISDN (B-TE2)

This functional group includes functions belonging to the functional group B-TE but with a broadband interface that complies with interface ITU-T Recommendations other than the B-ISDN interface ITU-T Recommendations or interfaces not included in ITU-T Recommendations.

#### 4.5.4 Terminal adapter for B-ISDN (B-TA)

This functional group includes functions broadly belonging to layer 1 and higher layers of the ITU-T Recommendation X.200 [10] reference model that allow a TE2 or a B-TE2 terminal to be served by a B-ISDN UNI.

## 5 UNI specifications

### 5.1 Interface location with respect to reference configuration

An interface point  $I_a$  is adjacent to the B-TE or the B-NT2 on their network side; interface point  $I_b$  is adjacent to the B-NT2 and to the B-NT1 on their user sides (see figure 4).

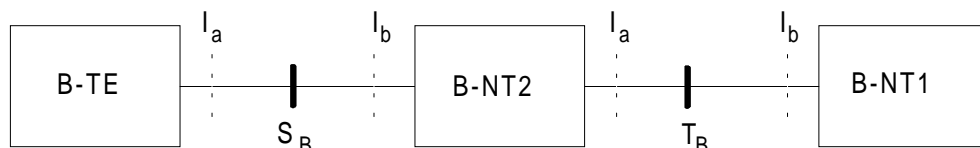
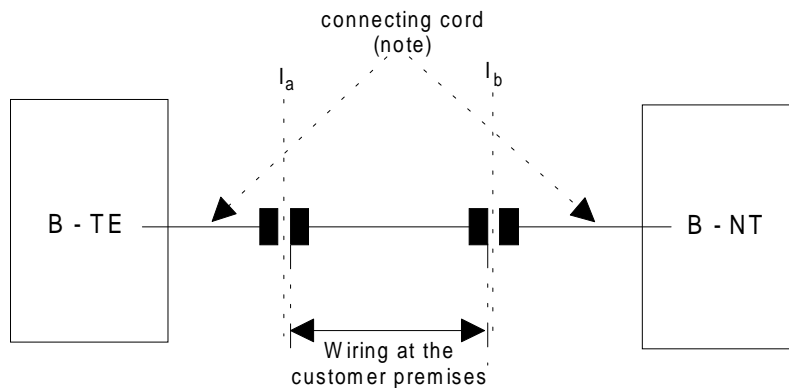


Figure 4: Reference configuration at reference points  $S_B$  and  $T_B$

### 5.2 Interface location with respect to the wiring configuration

The interface points are located between the socket and the plug of the connector attached to the B-TE, B-NT2 or B-NT1. The location of the interface point is shown in figure 5.

In this ETS, the term "B-NT" is used to indicate network terminating layer 1 aspects of B-NT1 and B-NT2 functional groups, and the term "TE" is used to indicate terminal terminating layer 1 aspects of B-TE1, B-TA and B-NT2 functional groups, unless otherwise indicated.



NOTE: The length of the connecting cord can be zero.

Figure 5: Wiring configuration

## 6 Service and layering aspects of the physical layer

### 6.1 Services provided to the ATM-layer

The physical layer provides for the transparent transmission of ATM-PDUs between physical layer Service Access Points (Ph-SAP). The ATM-PDU is called ATM cell. The ATM cell is defined in ITU-T Recommendation I.361 [6]. As no addressing is implemented in the physical layer only a single Ph-SAP can exist at the boundary between physical layer and ATM layer. The inter-arrival time between cells passed to the ATM layer is not defined (asynchronous transmission). The physical layer provides the ATM layer with timing information.

### 6.2 Service primitives exchanged with the ATM layer

The service primitives between physical layer and ATM-layer are defined in ITU-T Recommendation I.361, section 3.2 [6].

### 6.3 Sublayering of the physical layer

The physical layer is subdivided into two sublayers:

- the physical medium (PM) sublayer;
- the transmission convergence (TC) sublayer.

No service access point and service primitives are defined between the PM and the TC sublayers. The functions of the individual sublayer are defined in ITU-T Recommendation I.321 [12].

## 7 Physical medium characteristics at the $T_B$ and $S_B$ reference point of the UNI for 2 048 kbit/s

### 7.1 Bit rate and interface symmetry

The bit rate of the interface is 2 048 kbit/s. The interface is symmetric, i.e. it has the same bit rate in both transmission directions.

The nominal bit rate in free running clock mode shall be 2 048 kbit/s with a tolerance of 50 parts per million (ppm).



## 7.2 Physical characteristics

Only electrical interfaces are recommended. The implementation selected depends on the distance to be covered and user requirements arising from the details of the installation.

### 7.2.1 Electrical interface

#### 7.2.1.1 Interface range

The maximum range of the interface depends on the specific attenuation of the transmission medium used (e.g. twisted pair, coaxial cable) and is for further study.

#### 7.2.1.2 Transmission medium

Two coaxial cables or two twisted pairs, one for each direction, shall be used. The wiring configuration shall be point-to-point.

The impedance shall be respectively  $75 \Omega$  and  $120 \Omega$ . Further details (e.g. attenuation of the electrical path between the interface points  $I_a$  and  $I_b$ ) shall match the definitions according to ETS 300 166 [2].

#### 7.2.1.3 Electrical parameters at interface points $I_a$ and $I_b$

The digital signal presented at the output port and the port impedance should conform to ETS 300 166 [2] for the interface at 2 048 Mbit/s.

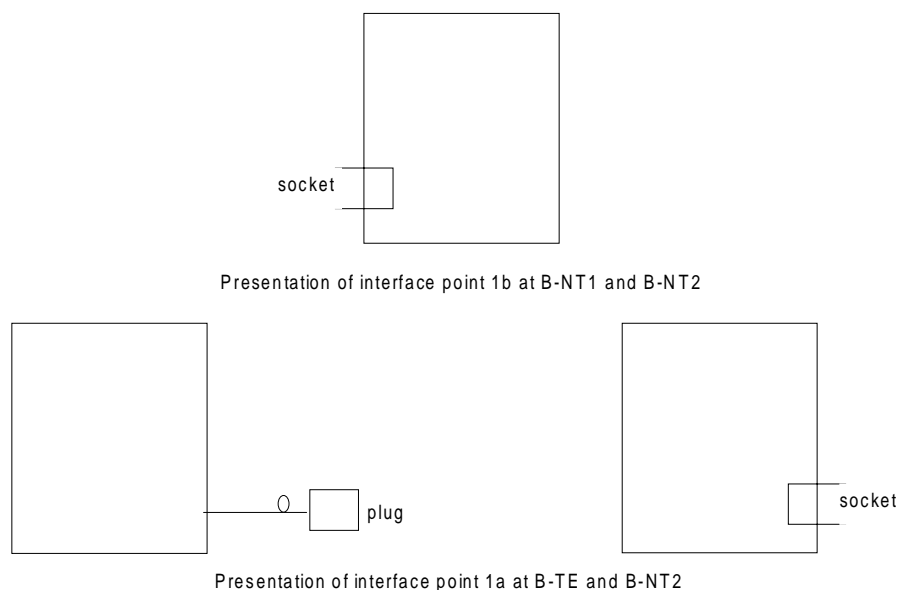
The digital signal presented at the input port and the port impedance should conform to ETS 300 166 [2] for the interface at 2 048 Mbit/s modified by the characteristics of the interconnecting coaxial pair or twisted pair.

#### 7.2.1.4 Electrical connectors

The presentation of interface point  $I_b$  at B-NT1 or B-NT2 shall be via a socket.

The presentation of interface point  $I_a$  at B-TE or B-NT2 shall be using either:

- a) a socket, i.e. the connection shall be made to the equipment toward the network with a cable with plugs on both ends; or
- b) an integral connecting cord with plug on the free end (see figure 6: Connector types).



**Figure 6: Connector types**

### 7.2.1.5 Line coding

The line coding shall be HDB-3; see ETS 300 166 [2].

### 7.2.1.6 Electromagnetic compatibility and electromagnetic interference requirements

The specification of respective values for EMC are for further study.

### 7.2.1.7 Jitter and Wander

For the electrical B-UNI, the interface output Jitter shall be in accordance with the appropriate limits given in ITU-T Recommendation G.823 [4].

Equipment having an electrical B-UNI (e.g. B-NT1, B-NT2, B-TE) and which meets the input Jitter tolerance and the Jitter transfer specifications given in ITU-T Recommendation G.823 [4], is assured of proper operation when the interface output Jitter conforms to the limits in ITU-T Recommendation G.823 [4].

Values and measurements for Terminal Failure Voltage (TFV) are for further study.

## 8 Power feeding

### 8.1 Provision of power

The provision of power to the B-NT1 via the UNI is optional. If the power is provided via the UNI, the following conditions shall apply:

- a separate pair of wires shall be used for the provision of power to the B-NT1 via the  $T_B$  reference point;
- the power sink shall be fed by either:
  - a source under the responsibility of the user when requested by the network provider;
  - a power supply unit under the responsibility of the network provider connected to the mains electric supply in the customer premises;
- the capability of the provision of power by the user side shall be available either:
  - as an integral part of the B-NT2/B-TE; and/or
  - physically separated from the B-NT2/B-TE as an individual power supply unit;
- a power source capable to feed more than one B-NT1 shall meet the requirements at each individual B-NT1 power feeding interface at the same point in time;
- a short circuit or overload condition in any B-NT1 shall not affect the power feeding interface of the other B-NT1s.

### 8.2 Power available at B-NT1

The requirements of power values at the B-NT1 are for further study.

### 8.3 Feeding voltage

The feeding voltage at the B-NT1 shall be in the range of -20 V to -57 V relative to ground.

## 8.4 Safety requirements

In order to harmonize power source and sink requirements the following is required:

- 1) the power source shall be protected against short circuits and overload;
- 2) the power sink of B-NT1 shall not be damaged by an interchange of wires.

With respect to the feeding interface of the power source, which is regarded as a touchable part in the sense of IEC 950 [11], the protection methods against electric shock specified in IEC 950 [11] may be applied.

## 9 Functions provided by the transmission convergence sublayer

### 9.1 Transfer capability for 2 048 kbit/s

At the physical level of the interface, at the  $T_B$  reference point, the bit rate shall be 2 048 kbit/s. The maximum bit rate available for user information cells, signalling cells and ATM and higher layers OAM information cells, excluding physical layer frame structure octets is 1 920 kbit/s.

### 9.2 Physical Layer aspects

The ATM cell structure shall be as defined in ITU-T Recommendation I.361 [6] and ATM cells are carried in a PDH based frame structure.

#### 9.2.1 Timing

In normal operation, timing for the transmitter is locked to the timing received from the network clock and derived from the line rate of the physical layer. To meet this requirement it is essential that the quality of the timing transported in the 2 048 kbit/s section is known. The latest version of G.704 [16] defines for this purpose the concept of Timing Marker, which uses one of the Si-bits of Timeslot 0 on a selectable basis.

The tolerance under fault conditions shall be 2 048 kbit/s  $\pm$  50 ppm (see ETS 300 166 [2]).

#### 9.2.2 Interface structure for 2 048 kbit/s

The bit stream of the interface has an external frame based on the PDH, as described in ITU-T Recommendation I.431 section 5.2 [3].

The ATM cell stream is directly mapped into the frame structure according to ITU-T Recommendation G.804 [1]. The ATM cells shall be octet aligned in the frame structure. Timeslot 0 (TS 0) shall be used for OAM functions. TS 16 shall not be used in this interface. TS 1 to TS 15 and TS 17 to TS 31 shall be used to transport the ATM cells (30 octets/125  $\mu$ s).

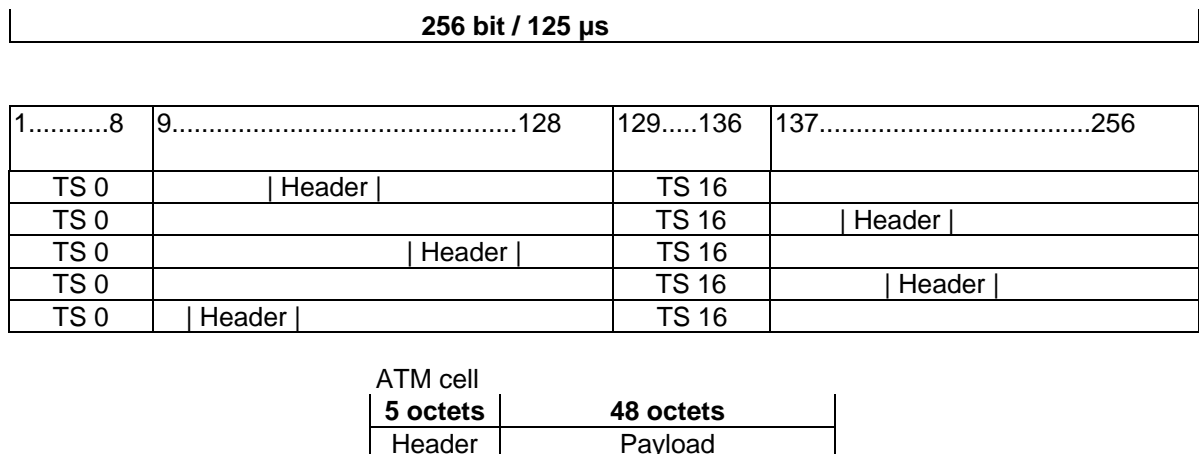


Figure 7: Frame structure for transport of ATM cells

**Table 1: Transmission Frame Types**

Frame type	Content of Slot 0 - bit number							
	1	2	3	4	5	6	7	8
Alignment Frame	Si	0	0	1	1	0	1	1
Non-alignment Frame	Si	1	A	Sa 4	Sa 5	Sa 6	Sa 7	Sa 8

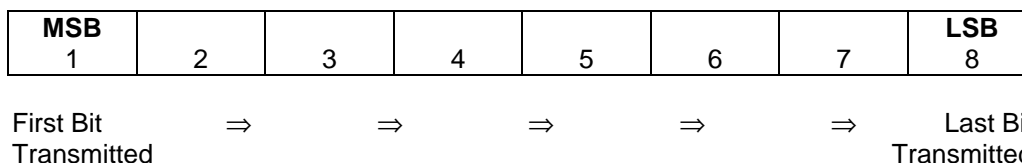
NOTE: The use of the Si bits is for the CRC-4 procedure and is according to table 2.

**Table 2: CRC-4 multiframe structure**

	SMF	Frame number	Bits 1 to 8 of the frame							
			1	2	3	4	5	6	7	8
<b>M u l t i f r a m e</b>	<b>I</b>	0	C1	0	0	1	1	0	1	1
		1	0	1	A	Sa4	Sa5	Sa6	Sa7	Sa8
		2	C2	0	0	1	1	0	1	1
		3	0	1	A	Sa4	Sa5	Sa6	Sa7	Sa8
		4	C3	0	0	1	1	0	1	1
		5	1	1	A	Sa4	Sa5	Sa6	Sa7	Sa8
		6	C4	0	0	1	1	0	1	1
	7	0	1	A	Sa4	Sa5	Sa6	Sa7	Sa8	
	<b>II</b>	8	C1	0	0	1	1	0	1	1
		9	1	1	A	Sa4	Sa5	Sa6	Sa7	Sa8
		10	C2	0	0	1	1	0	1	1
		11	1	1	A	Sa4	Sa5	Sa6	Sa7	Sa8
		12	C3	0	0	1	1	0	1	1
		13	E	1	A	Sa4	Sa5	Sa6	Sa7	Sa8
		14	C4	0	0	1	1	0	1	1
15		E	1	A	Sa4	Sa5	Sa6	Sa7	Sa8	

Key:  
 SMF: Sub-multiframe A: Alarm bit E: CRC-4 error bit C1 to C4: CRC-4 bits  
 FAW: x001 1011 (frame alignment)

For all representations shown in this ETS in binary format, bits are numbered within the octet as shown in figure 8, with the order of transmission being from left to right.



NOTE: The bit numbering used in this figure is different from the convention used in ITU-T Recommendation I.361 [6].

**Figure 8: Order of transmission of bits within a byte**

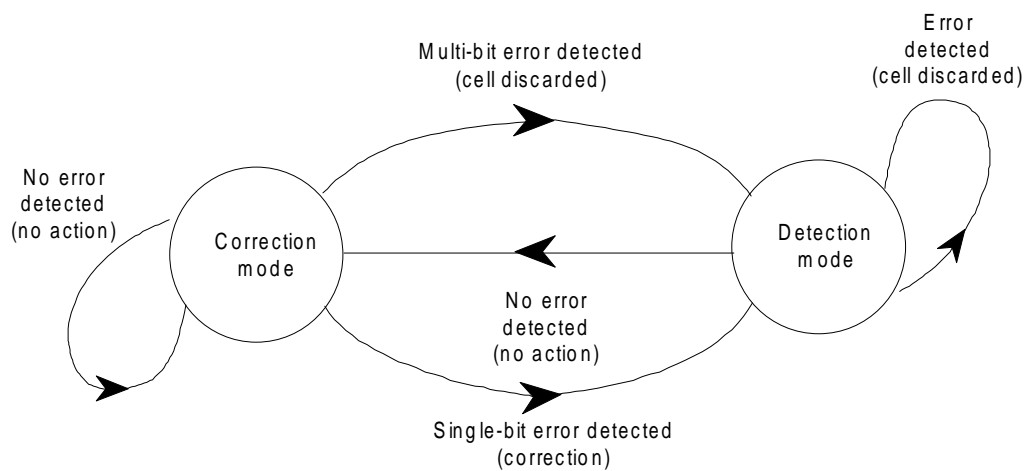
### 9.3 Header error control

#### 9.3.1 Header error control functions

The Header Error Control (HEC) covers the entire cell header. The code used for this function is capable of either:

- single bit error correction; or
- multiple bit error detection.

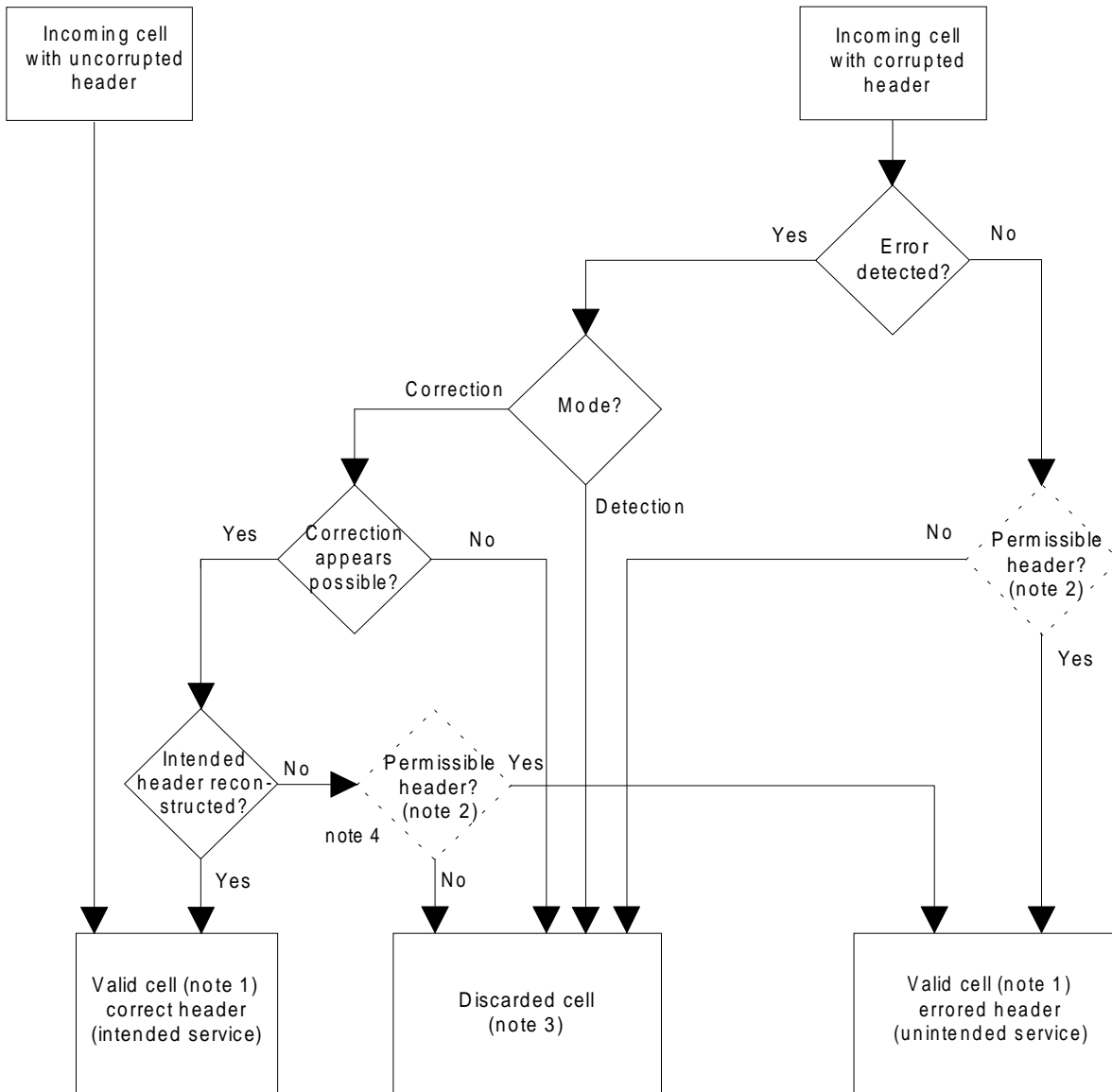
The detailed description of the HEC procedure is given in subclause 9.3.2. Briefly, the transmitting side computes the HEC field value. The receiver has two modes of operation as shown in figure 9. The default mode provides for single-bit error correction. Each cell header is examined and, if an error is detected, one of two actions take place. The action taken depends on the state of the receiver. In "correction mode" only single bit errors can be corrected and the receiver switches to "detection mode". In "detection mode", all cells with detected header errors are discarded. When a header is examined and found not to be in error, the receiver switches to "correction mode". The term "no action" in figure 9 means no correction is performed and no cell is discarded.

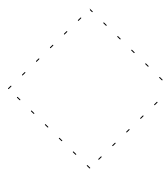


**Figure 9: Header Error Control (HEC)-receiver modes of operation**

The flow chart in figure 10 shows the consequences of errors in the ATM cell header. The error protection function provided by HEC provides both recovery from single bit header errors, and a low probability of the delivery of cells with errored headers under bursty error conditions. The error characteristics of fibre based transmission systems appear to be a mix of single-bit errors and relatively large burst errors. For some transmission systems the error correction capability may not be invoked.

Annex A of ETS 300 300 [13] gives information on how random bit errors impact the probability of occurrence of discarded cells and valid cells with errored headers.



 – Functions usually performed by the ATM layer

- NOTE 1: Intended service means the service requested by the originator, while unintended service means a possible service, but not that required by the originator.
- NOTE 2: An example of an impermissible header is a header whose VPI/VCI is neither allocated to a connection nor pre-assigned to a particular function (idle cell, OAM cell, etc.). In many instances, the ATM-layer will decide if the cell header is permissible.
- NOTE 3: A cell is discarded if its header is declared to be invalid, or if the header is declared to be valid and the resulting header is impermissible.
- NOTE 4: Some of the tests shown are just for explanation and not implementable as such. Specially, those for error detection and intended header reconstructed.

**Figure 10: Consequences of errors in ATM cell header**

### 9.3.2 Header error control sequence generation

The transmitter calculates the HEC value across the entire ATM cell header and inserts the result in the appropriate header field.

The notation used to describe the header error control is based on the property of cyclic codes (e.g. code vectors such as "1000 0001 00001" can be represented by a polynomial  $P(x) = x^{12} + x^5 + 1$ ). The elements of an n-element code word are thus the coefficients of a polynomial of order n-1. In this application, these coefficients can have the value 0 or 1 and the polynomial operations are performed using modulo 2 operations. The polynomial representing the content of a header excluding the HEC field is generated using the first bit of a header as the coefficient of the highest order term.

The HEC field shall be an 8-bit sequence. It shall be the remainder of the division (modulo 2) by the generator polynomial  $x^8 + x^2 + x + 1$  of the product  $x^8$  multiplied by the content of the header excluding the HEC field.

At the transmitter, the initial content of the register of the device computing the remainder of the division is pre-set to all 0s and is then modified by division of the header excluding the HEC field by the generator polynomial (as described above); the resulting remainder is transmitted as the 8-bit HEC.

To significantly improve the cell delineation performance in the case of bit-slips the following is recommended:

- the check bits calculated by the use of the check polynomial are added (modulo 2) to an 8-bit pattern before being inserted in the last octet of the header;
- the recommended pattern is "0101 0101" (the left bit is the most significant bit);
- the receiver shall subtract (which is equal to add modulo 2) the same pattern from the 8 HEC bits before calculating the syndrome of the header.

This operation in no way affects the error detection/correction capabilities of the HEC.

As an example, if the first 4 octets of the header were all zeros, the generated header before scrambling would be "00000000 00000000 00000000 00000000 01010101". The starting value for the polynomial check is all "0"s.

### 9.4 Idle cells

Idle cells cause no action at a receiving node except for cell delineation, including HEC verification. They are inserted and discarded for cell rate decoupling.

Idle cells are identified by the standardized pattern for the cell header shown in table 3.

**Table 3: Header pattern for idle cell identification**

	Octet 1	Octet 2	Octet 3	Octet 4	Octet 5
Header pattern	00000000	00000000	00000000	00000001	HEC = Valid code = 01010010

There is no significance to any of these fields from the point of view of the ATM layer, as idle cells are not passed to the ATM layer.

The content of the information field is "0110 1010" repeated 48 times.

### 9.5 Cell delineation and scrambling

#### 9.5.1 Cell delineation and scrambling objectives

Cell delineation is the process which allows identification of the cell boundaries. The ATM cell header contains a header error control (HEC) field which is used to achieve cell delineation.

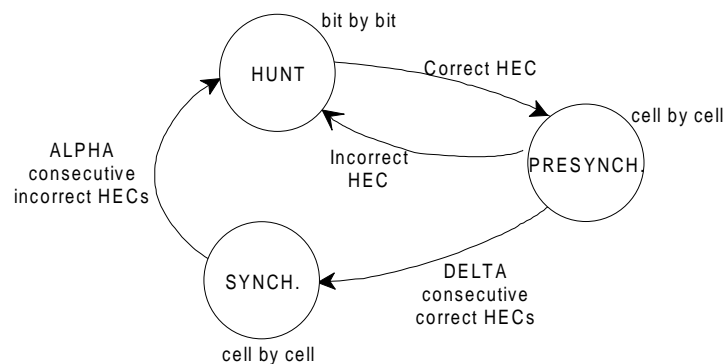
The ATM signal is required to be self-supporting in the sense that it has to be transparently transported on every network interface without any constraints from the transmission systems used.

Scrambling shall be used to improve the security and robustness of the HEC cell delineation mechanism as described in subclause 9.5.4. In addition, it randomizes the data in the information field, for possible improvement of the transmission performance.

### 9.5.2 Cell delineation algorithm

Cell delineation shall be performed by using the correlation between the header bits to be protected (32 bits) and the relevant control bits (8 bits), introduced in the header by the HEC using a shortened cyclic code with generating polynomial  $G(x) = x^8 + x^2 + x + 1$ .

Figure 11 shows the state diagram of the HEC cell delineation method.



NOTE: The "correct HEC" means the header has no bit error (syndrome is zero) and has not been corrected.

Figure 11: Cell delineation state diagram

The details of the state diagram, given in figure 11, are described below:

- 1) in the HUNT state, the delineation process shall be performed by checking bit by bit for the correct HEC (i.e. syndrome equals zero) for the assumed header field. Once such an agreement is found, it is assumed that one header has been found, and the method enters the PRESYNCH state;
- 2) in the PRESYNCH state, the delineation process shall be performed by checking cell by cell for the correct HEC. The process repeats until the correct HEC has been confirmed DELTA times consecutively and then the method enters the SYNC state. If an incorrect HEC is found, the process returns to the HUNT state. The total number of consecutive correct HEC require to move from the HUNT state to the SYNC state is therefore DELTA + 1;
- 3) in the SYNC state the cell delineation will be assumed to be lost if an incorrect HEC is obtained ALPHA times consecutively;
- 4) cells with correct HECs (or cell headers with single bit errors which are corrected) that are processed while the SYNC state shall be passed to the ATM layer. Cells with correct HECs that are checked while in the PRESYNCH state may optionally be passed to the ATM layer, but only when they are part of the DELTA consecutive correct HECs necessary for transition to the SYNC state. The cell associated with the first correct HEC (in the HUNT state) may also optionally be passed to the ATM layer in conjunction with the DELTA cells just mentioned. In any case, idle cells and Physical Layer OAM cells are not passed to the ATM layer.

The parameters ALPHA and DELTA shall be chosen to make the cell delineation process as robust and secure as possible while satisfying the performance specified in subclause 9.5.3.

Robustness against false misalignments due to bit errors depends on ALPHA.

Robustness against false delineation in the re-synchronization process depends on the value of DELTA. Values of ALPHA = 7 and DELTA = 6 are recommended.



Out Of Cell (OCD) anomaly persistence time is 50 ms, as the time before the state change from OCD to Loss Of Cell (LCD) will be forced. A LCD defect terminates when the cell delineation process enters and remains in the Sync state for a persistence time of 50 ms (see figure 11).

### 9.5.3 Cell delineation performance

For further study.

### 9.5.4 Scrambler operation

The following polynomial has been identified for the physical layer:

self synchronizing scrambler  $x^{43} + 1$ .

This self synchronizing scrambler polynomial has been selected to minimize the error multiplication (two) introduced by the self synchronized scrambler.

The operation of this scrambler in relation to the HEC cell delineation state diagram is as follows:

- the scrambler randomizes the bits of the information field only (avoiding error multiplication in the header);
- during the five octets header the scrambler operation is suspended and the scrambler state retained;
- in the HUNT state the descrambler is disabled;
- in the PRESYNC and SYNC states the descrambler is enabled for a number of bits equal to the length of the information field, and again disabled for the following assumed header.

## 10 UNI related OAM and operational functions

The OAM functions associated with the UNI are described in ITU-T Recommendation I.610 [9].

### 10.1 Operational functions

#### 10.1.1 Definition of signals

##### Physical Layer OAM

The error performance monitoring is performed by the CRC-4 procedure defined in ITU-T Recommendation G.706 [15]. The reporting of the RAI (RDI) and LCD are performed by dedicated bits in TS0 of the frame structure (ITU-T Recommendation G.704 [16]).

##### Detection/Reception and Generation of defects

At the **Physical Layer** (E1) the defects LOS, LOF, LCD, AIS, RAI (RDI), REI and performance monitoring (CRC-4) are detected and generated in the following way:

**Table 4: Detection of transmission alarms (E1 receive direction)**

<b>E1-defect</b>	<b>E1 defect detection condition</b>	<b>defect clearing condition</b>
LOS	according to ITU-T Recommendation G.775 [18]	according to ITU-T Recommendation G.775 [18]
LOF	3 consecutive invalid frame alignment signals (FAS) have been received  (ITU-T Recommendation G.706 [15]/section 4.1)	ITU-T Recommendation G.706 [15]/section 4.1:  1) presence of a correct FAS  2) absence of FAS in the following frame (bit 2 is a "1")  3) for the second time presence of a correct FAS
LCD (note 1)	ATM cell synchronization is in state HUNT- or PRESYNC (ITU-T Recommendation I.432 [8])	ATM cell synchronization is in state SYNC (ITU-T Recommendation I.432 [8])
AIS	continuous stream of ones, including FAS  (ITU-T Recommendation G.732 [17])	ITU-T Recommendation G.706 [15]/section 4.1:  1) presence of a correct FAS  2) absence of FAS in the following frame (bit 2 is a "1")  3) for the second time presence of a correct FAS
RAI (RDI)	ITU-T Recommendation G.704 [16]: Alarm bit "A" (bit 3 of the frame alignment signal) is set to "1"	ITU-T Recommendation G.704 [16]: Alarm bit "A" (bit 3 of the frame alignment signal) is set to "0"

**Table 5: Detection of transmission maintenance signals (E1 receive direction)**

<b>E1-signal</b>	<b>maintenance signal detection</b>	<b>maintenance signal clearing condition</b>
CRC-4	CRC-4 error of the received signal detected	no CRC-4 error detected

**Table 6: Generation of transmission alarms**

<b>E1-alarm</b>	<b>E1 alarm coding</b>	<b>condition for alarm generation</b>
AIS	continuous stream of ones, including FAS	LOS, LOF
RAI (RDI)	Alarm bit "A" (bit 3 of the frame alignment signal) is set to "1"	LOS, LOF, AIS received  LCD

**Table 7: Generation of transmission maintenance signals**

<b>E1-signal</b>	<b>E1 maintenance signal coding</b>	<b>condition for maintenance signal generation</b>
CRC-4	Bits C1..C4 of FAS	CRC-4 is calculated over all bits of a 8 frame sub-multiframe (block size i.e. 2 048 bits) (ITU-T Recommendations G.704 [16]/and G.706 [15])

At the **ATM-Layer** the defects e.g. VP-AIS, VP-RDI and VC-AIS, VC-RDI shall be detected and generated as defined in ITU-T Recommendation I.610 [9].

## 10.1.2 Definitions of state tables at network and user sides

The user side and network side of the interface have to inform each other of the layer 1 states in relation to the different defects that could be detected.

For the purpose, two state tables are defined, one at the user side and one at the network side. States at the user side (F states) are defined in subclause 10.1.2.1 and states at the network side (G states) are defined in subclause 10.1.2.2. The state tables are defined in subclause 10.1.2.4.

Fault conditions FC1 to FC4 that could occur at the network side or between the network side and user side are defined in figure 12. These fault conditions directly affect the F and G states. Information on these fault conditions is exchanged between the user and network sides in the form of signals defined in subclause 10.1.1.

NOTE 1: Only stable states needed for OAM of the user and the network side of the interface (system reactions, user and network relevant information) are defined.

NOTE 2: The user does not need to know where a failure is located in the network. The user should be informed on the availability and the continuity of the layer 1 service.

NOTE 3: The user has all information relative to the performance associated with each direction of its adjacent section. The supervision of the quality of this section is the user's responsibility.

### 10.1.2.1 Layer 1 states on the user side of the interface

#### **F0 state: loss of power on the user side:**

- in general, the TE can neither transmit nor receive signals.

#### **F1 state: operational state:**

- network timing and layer 1 service is available;
- the user side transmits and receives operational frames with associated CRC bits and with temporary CRC error information (note 1);
- the user side checks the received frames and the associated CRC bits, and transmits to the network side operational frames containing the CRC error information, if a CRC error is detected.

#### **F2 state: fault condition No. 1:**

- this fault state corresponds to the fault condition FC1;
- network timing is available at the user side;
- the user side receives operational frames with associated CRC bits and with temporary CRC error information (note 1);
- the received frames contain RAI;
- the user side transmits operational frames with associated CRC bits;
- the user side checks the received frames and the associated CRC bits and transmits to the network side operational frames containing the CRC error information, if a CRC error is detected.

#### **F3 state: fault condition No. 2:**

- this fault state corresponds to the fault condition FC2;
- network timing is not available at the user side;
- the user side detects incoming LOS, (this will involve LOF);
- the user side transmits operational frames with associated CRC bits and RAI, using timing from an internal oscillator.

**F4 state: fault condition No. 3:**

- this fault state corresponds to fault condition FC3;
- network timing is not available at the user side;
- the user side detects AIS;
- the user side transmits to the network side operational frames associated CRC bits and RAI.

**F5 state: fault condition No. 4:**

- this fault state corresponds to the fault condition FC4;
- network timing is available at the user side;
- the user side receives operational frames with continuous CRC error information (optional) (note 2);
- the received frames contain RAI;
- the user side transmits operational frames with associated CRC bits;
- the user side checks the received frames and the associated CRC bits. It may transmit to the network side operational frames containing the CRC error information, if a CRC error is detected.

**F6 state: Power on state:**

- this is a transient state and the user side may change the state after detection of the signal received.

NOTE 1: The interpretation of the CRC error information depends on the option used in the network (see ITU-T Recommendation I.604 [14]).

NOTE 2: Only in options 2 and 3 of annex A of ITU-T Recommendation I.604 [14]. The condition of "continuous CRC error information" corresponds to loss of incoming signal or loss of frame alignment on the network side.

**10.1.2.2 Layer 1 states at the network side of the interface**

**G0 state: loss of power on the network side:**

- in general, the B-NT1 can neither transmit nor receive any signal.

**G1 state: operational state:**

- the network timing and layer 1 service is available;
- the network side transmits and receives operational frames with associated CRC bits and temporary CRC error information;
- the network side checks the received frames and the associated CRC bits and transmits to the user side the CRC error information, if a CRC error is detected.

**G2 state: fault condition No. 1:**

- this fault state corresponds to the fault condition FC1;
- network timing is provided to the user side;
- the network side receives operational frames with associated CRC bits;
- the network side transmits to the user side operational frames with associated CRC bits and RAI. The operational frames may contain CRC error information (note 1).

**G3 state: fault condition No. 2:**

- this fault state corresponds to the fault condition FC2;
- network timing is not provided to the user side;
- the network side transmits to the user side operational frames with associated CRC bits;
- the network side receives operational frames with associated CRC bits and RAI.

**G4 state: fault condition No. 3:**

- this fault state corresponds to the fault condition FC3;
- network timing is not provided to the user side;
- the network side transmits AIS;
- the network side receives operational frames with associated CRC bits and RAI.

**G5 state: fault condition No. 4:**

- this fault state corresponds to the fault condition FC4;
- network timing is provided to the user side;
- the network side detects incoming LOS or LOF;
- the network side transmits to the user side operational frames with associated CRC bits and RAI and continuous CRC error information (note 2).

**G6 state: power on state:**

- this is a transient state and the network side may change the state after detection of the signal received.

NOTE 1: The interpretation of the CRC error information depends on the option used in the network (see ITU-T Recommendation I.604 [14]).

NOTE 2: Only in options 2 and 3 of annex A of ITU-T Recommendation I.604 [14].

**10.1.2.3 Definition of primitives**

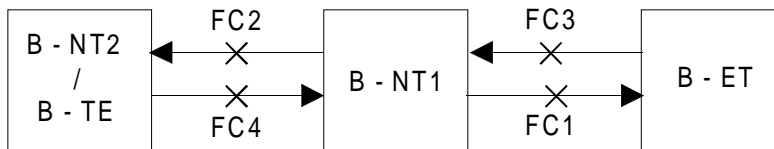
The following primitives should be used between the physical media dependent layer and the management entity (Management Physical Header (MPH) primitives) and the upper layer (Physical Header (PH) primitives), respectively.

PH-AI	PH ACTIVE INDICATION
PH-DI	PH DEACTIVE INDICATION
MPH-AI	MPH ACTIVATE INDICATION (is used as error recovery and initialization information)
MPH-EIn	MPH ERROR INDICATION with parameter n (n defines the failure condition relevant to the reported error)
MPH-CIn	MPH CORRECTION INDICATION with parameter n (n defines the failure condition relevant to the reported error)

10.1.2.4 State tables

Operational functions are defined in table 8 for the layer 1 states at the user side of the interface and in table 9 for the network side. The exact reaction in case of double faults may depend on the type of double fault condition and the sequence in which they occur.

Location of fault conditions:



Fault condition	Definition
FC1	Fault in the upstream direction in access digital section
FC2	Fault in the downstream direction of the interface
FC3	Fault in the downstream direction in access digital section
FC4	Fault in the upstream direction of the interface

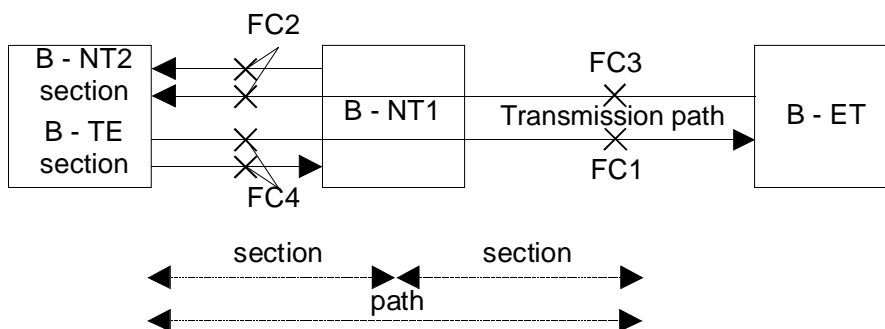


Figure 12: Fault conditions and operational span of section path maintenance signals

Table 8: Primary rate layer 1 state matrix at user side of the interface

	Initial state	F0	F1	F2 <sup>b)</sup>	F3	F4	F5	F6
<b>Definition of the states</b>	<b>Operational condition or failure condition</b>	Power off at user side	Operational	FC 1	FC 2	FC 3	FC 4	Power on at user side
	<b>Signal transmitted towards interface</b>	No signal	Normal operational frames	Normal operational frames	Frames with RAI	Frames with RAI	Normal operational frames	No signal
<b>New event detected at the receiving side</b>	<b>Loss of TE power</b>	/	PH-DI MPH-EI 0 F 0	MPH-EI 0 F 0	MPH-EI 0 F 0	MPH-EI 0 F 0	MPH-EI 0 F 0	MPH-EI 0 F 0
	<b>Return of TE power</b>	F6	/	/	/	/	/	/
	<b>Normal operational frames from network side</b>	/	-	PH-AI MPH-AI F 1	PH-AI MPH-AI F 1	PH-AI MPH-AI F 1	PH-AI MPH-AI F 1	/
	<b>Reception of RAI<sup>a)</sup></b>	/	PH-DI MPH-EI 1 F 2	-	MPH-EI 1 F 2	MPH-EI 1 F 2	MPH-EI 1 F 2	MPH-EI 1 F 2
	<b>Loss of -signal or -frame alignment or -cell delineation</b>	/	PH-DI MPH-EI 2 F 3	MPH-EI 2 F 3	-	MPH-EI 2 F 3	MPH-EI 2 F 3	MPH-EI 2 F 3
	<b>Reception of AIS</b>	/	PH-DI MPH-EI 3 F 4	MPH-EI 3 F 4	MPH-EI 3 F 4	-	MPH-EI 3 F 4	MPH-EI 3 F 4
	<b>Reception of RAI and continuous CRC error report<sup>a)</sup></b>	/	PH-DI MPH-EI 4 F 5	MPH-EI 4 F 5	MPH-EI 4 F 5	MPH-EI 4 F 5	-	MPH-EI 4 F 5

Single fault conditions

-	No state change
/	Impossible situation
PH - x	Issue primitive x
MPH - y	Issue management primitive y
F z	Go to state F z

PH - AI                      PH ACTIVATE INDICATION

PH - DI                      PH DEACTIVATE INDICATION

MPH - EI n                  MPH ERROR INDICATION with parameter n (n = 0 to 4)

a) This event covers different network options. The network option 2 and 3 (see ITU-T Recommendation I.604 [14]) of the 2 048 kbit/s system (which include CRC processing in the digital transmission link) provide CRC error information which allows the user-side equipment to localize a fault, indicated by means of RAI, to either:

- i) the network side (FC 1), if frames without continuous CRC error reports are received; or
- ii) the user side (FC 4), if frames with continuous CRC reports are received.

If network options other than 2 and 3 of the 2 048 kbit/s system apply, the faults FC 1 and FC 4 are indicated identically at the interface, and therefore, the signal "RAI with continuous error report" does not occur.

b) This state covers two user options:

- i) if a TE adopting the option to distinguish between F 2 and F 5 (given by options 2 and 3 ) is used, but the network does not provide the distinction (see note), then signal "RAI with continuous CRC error report" will not occur and the TE always enters state F 2 on receipt of RAI;
- ii) the user option of not processing CRC error information when accompanied with RAI, even if provided, merge states F 2 and F 5.

NOTE: The interpretation of the CRC error information depends on the option used in the network (see ITU-T Recommendation I.604 [14]).



Table 9: Primary rate layer 1 state matrix at network side of the interface

	Initial state	G0	G1	G2	G3	G4	G5 a)	G6	
Definition of the states	Operational condition or failure condition	Power off at NT	Operational	FC 1	FC 2	FC 3	FC 4	Power on at NT	
	Signal transmitted towards interface	No signal	Normal operational frames	RAI b)	Normal operational frames	AIS	RAI b)	No signal	
New event detected at the receiving side	Loss of NT power	/	PH-DI MPH-EI 0 G 0	MPH-EI 0 G 0	MPH-EI 0 G 0	MPH-EI 0 G 0	MPH-EI 0 G 0	MPH-EI 0 G 0	
	Return of NT power	G 6	/	/	/	/	/	/	
	Normal operational frames. No internal network failure	/	-	PH-AI MPH-AI G 1	PH-AI MPH-AI G 1	PH-AI MPH-AI G 1	PH-AI MPH-AI G 1	/	
	Internal network failure FC 1	/	PH-DI MPH-EI 1 G 2	-	MPH-EI 1 <sup>c)</sup> G 2	MPH-EI 1 <sup>c)</sup> -	MPH-EI 1 <sup>c)</sup> -	MPH-EI 1 <sup>c)</sup> -	MPH-EI 1 <sup>c)</sup> G 2
					X	G 2	G 2		
	Reception of RAI a) FC 2	/	PH-DI MPH-EI 2 G 3	-	MPH-EI 2 <sup>c)</sup> -	-	MPH-EI 2 <sup>c)</sup> -	MPH-EI 2 <sup>c)</sup> -	MPH-EI 2 G 3
					G 3		G 3	G 3	
Internal network failure FC 3	/	PH-DI MPH-EI 3 G 4	MPH-EI 3 <sup>c)</sup> G 4	MPH-EI 3 <sup>c)</sup> G 4	MPH-EI 3 <sup>c)</sup> G 4	-	MPH-EI 3 <sup>c)</sup> G 4	MPH-EI 3 G 4	
				X	X		X		
Loss of operational frames FC 4 a)	/	PH-DI MPH-EI 4 G 5	MPH-EI 4 <sup>c)</sup> G 5	MPH-EI 4 <sup>c)</sup> G 5	MPH-EI 4 <sup>c)</sup> G 5	MPH-EI 4 <sup>c)</sup> -	-	MPH-EI 4 <sup>c)</sup> G 5	
				X	X	G 5			

Single fault conditions

-	No state change
/	Impossible situation
PH - x  MPH - y  G z	Issue primitive x  Issue management primitive y  Go to state G z

Double fault conditions

MPH - y G z	Second fault is dominant. Actions to be taken when second fault occurs.
X	The disappearance of the first fault is not visible at the interface since the second fault is dominant and the state has changed already to G z.
MPH - y	First fault is dominant, therefore the state will not change when the second fault occurs, but the error indication may be given to the management if possible.
G z	Action to be taken when first (dominant) fault disappears.

PH - AI                      PH ACTIVATE INDICATION

PH - DI                      PH DEACTIVATE INDICATION

MPH - EI n                      MPH ERROR INDICATION with parameter n (n = 0 to 4)

- a) In case of no CRC processing in the digital link, the state G 5 is identical to state G 2.
- b) In options 2 and 3 of the 2 048 kbit/s systems, the RAI signal shall contain CRC error information of the section between TE and NT which can be used by the user to localize faults FC 1 and FC 4. In option 1, the faults FC 1 and FC 4 are identically at the interface.
- c) The issue of this primitive depends on the capability of the digital transmission system and the option used in the network.

**Annex A (informative): Bibliography**

- ITU-T Recommendation G.707: "Network Node Interfaces for the Synchronous Digital Hierarchy (SDH)".

## History

Document history			
August 1996	Public Enquiry	PE 105:	1996-04-08 to 1996-08-30
January 1997	Vote	V 9713:	1997-01-28 to 1997-03-28
April 1997	First Edition		