



EUROPEAN
TELECOMMUNICATION
STANDARD

FINAL DRAFT
pr **ETS 300 731**

November 1996

Source: EBU/CENELEC/ETSI JTC

Reference: DE/JTC-PALplus

ICS: 33.020

Key words: Broadcasting, analogue, TV, wide screen

European Broadcasting Union



Union Européenne de Radio-Télévision

Television Systems;
Enhanced 625-line Phased Alternate Line (PAL)
television;
PALplus

ETSI

European Telecommunications Standards Institute

ETSI Secretariat

Postal address: F-06921 Sophia Antipolis CEDEX - FRANCE

Office address: 650 Route des Lucioles - Sophia Antipolis - Valbonne - FRANCE

X.400: c=fr, a=atlas, p=etsi, s=secretariat - **Internet:** secretariat@etsi.fr

Tel.: +33 4 92 94 42 00 - Fax: +33 4 93 65 47 16

Copyright Notification: No part may be reproduced except as authorized by written permission. The copyright and the foregoing restriction extend to reproduction in all media.

© European Telecommunications Standards Institute 1996.

© European Broadcasting Union 1996.

All rights reserved.

Contents

Foreword	7
1 Scope	9
2 Normative references	9
3 Abbreviations.....	9
4 Basic PALplus system description	10
4.1 Introduction	10
4.2 Normative features of a PALplus transmission.....	11
5 The PALplus signal	12
5.1 Input picture signal to the PALplus encoder	12
5.2 The encoded composite PALplus signal.....	12
6 The PALplus encoding processes.....	15
6.1 Vertical conversion.....	16
6.1.1 Encoder vertical conversion of luminance.....	16
6.1.2 Encoder vertical conversion of chrominance	16
6.1.3 430-line letterbox.....	17
6.2 Vertical helper encoding	20
6.2.1 Helper amplitude	20
6.2.2 Modulation.....	20
6.2.3 Description of helper processing.....	21
6.2.4 Baseband helper	25
6.3 Motion Adaptive Colour Plus.....	25
6.3.1 Pre-processing in the encoder	26
6.3.2 Motion detector operation.....	29
6.3.3 Non-PALplus use of Motion Adaptive Colour Plus	32
6.4 PAL encoding.....	32
6.4.1 Luminance.....	33
6.4.2 Chrominance	33
6.5 Reference signals	33
6.5.1 Helper reference signals with baseband helper	35
6.6 Signalling	35
Annex A (normative): Filter and look-up table coefficients.....	37
A.1 General rules for filter descriptions	37
A.1.1 General rules for horizontal filters.....	37
A.1.2 General rules for vertical filters	37
A.2 Vertical conversion	37
A.2.1 ENC_Y_QMF (camera mode)	37
A.2.2 ENC_Y_QMF (film mode).....	42
A.2.3 ENC_UV_C_VSRC.....	45
A.2.4 ENC_UV_F_VSRC	47
A.3 Helper encoding	49
A.3.1 ENC_BB_US.....	49
A.3.2 ENC_BB_PRE_MOD_LPF_SS	49
A.3.3 ENC_BB_POST_MOD_NYQ.....	50
A.3.4 LUT_BB_ENC (film mode).....	50
A.3.5 LUT_BB_ENC (camera mode).....	51

A.4	Motion Adaptive Colour Plus	52
A.4.1	Y_BSPLIT.....	52
A.4.2	ENC_Y_IFA.....	52
A.4.3	ENC_UV_LPF	53
A.4.4	VERT_IFA	53
A.4.5	ENC_MD_UV_LPF.....	54
A.4.6	ENC_M_US.....	54
A.4.7	LUT_IFD_U_CLIP	55
A.4.8	LUT_IFD_V_CLIP	56
A.4.9	LUT_MD_M.....	57
A.4.10	LUT_ENC_MD_YL.....	58
A.4.11	LUT_ENC_MD_CS	58
A.5	PAL encoding	58
A.5.1	ENC_UV_US.....	58
Annex B (informative):	Encoder filter plots	59
Annex C (informative):	The PALplus decoder	64
C.1	General.....	64
C.1.1	Composite PALplus input signal.....	64
C.1.2	Decoder output signal	64
C.2	Overview of the PALplus decoding process	65
C.2.1	PAL decoding.....	65
C.2.2	MACP post-processing	66
C.2.2.1	Motion detector operation	69
C.2.3	Helper processing	72
C.2.4	Vertical conversion of luminance	73
C.2.5	Vertical conversion of chrominance	73
C.2.6	Use of the Line 23/623 reference signals to assist vertical conversion.....	76
Annex D (informative):	Reference PALplus decoder: filter and look-up-table coefficients	77
D.1	General rules for filter descriptions.....	77
D.1.1	General rules for horizontal filters	77
D.1.2	General rules for vertical filters	77
D.2	Vertical conversion	77
D.2.1	DEC_Y_QMF (camera mode).....	77
D.2.2	DEC_Y_QMF (film mode)	80
D.2.3	DEC_UV_VSRC.....	82
D.2.4	DEC_UV_VSRC_NDL.....	84
D.3	Helper decoding.....	87
D.3.1	DEC_BB_PRE_MOD	87
D.3.2	DEC_BB_POST_MOD_LPF_ISS	87
D.3.3	LUT_BB_DEC (film mode).....	88
D.3.4	LUT_BB_DEC (camera mode)	89
D.4	Motion Adaptive Colour Plus, decoder	90
D.4.1	Y_BSPLIT.....	90
D.4.2	DEC_Y_VAA	90
D.4.3	DEC_UV_LPF	91
D.4.4	VERT_IFA	92
D.4.5	DEC_MD_UV_LPF.....	93
D.4.6	DEC_M_US.....	93
D.4.7	LUT_IFD_U_CLIP	94
D.4.8	LUT_IFD_V_CLIP	95
D.4.9	LUT_MD_M.....	96
D.4.10	LUT_DEC_MD_YL.....	97
D.4.11	LUT_DEC_MD_CS	97

D.5	PAL decoding	97
D.5.1	DEC_UV_DS_LPF	97
D.5.2	DEC_CHROM_BPF	97
Annex E (informative):	Decoder filter plots	98
Annex F (informative):	Receivers for the PALplus system	102
F.1	General	102
F.2	Receiver IF characteristics	102
F.3	Features included in a PALplus receiver	102
F.4	Receiver switching time in response to changes signalled by the WSS	103
F.5	Use of Wide Screen Signalling (WSS)	103
F.5.1	PALplus	103
F.5.2	Non-PALplus Motion Adaptive Colour Plus	104
F.5.3	Conventional PAL	104
F.5.4	Conventional PAL with helper	104
F.5.5	Transmissions transcoded into SECAM	104
Annex G (informative):	Application of ghost cancellation	105
Annex H (informative):	Studio production requirements	106
H.1	General	106
H.2	Limitations of the composite PALplus signal	106
H.3	Camera mode and film mode	107
H.4	Programme junctions between transmissions in PALplus and PAL	107
H.5	Open subtitles and logos	108
H.6	Non-PALplus use of Motion Adaptive Colour Plus	108
History	109

Blank page

Foreword

This final draft European Telecommunication Standard (ETS) has been produced by the Joint Technical Committee (JTC) of the European Broadcasting Union (EBU), Comité Européen de Normalisation ELEctrotechnique (CENELEC) and the European Telecommunications Standards Institute (ETSI), and is now submitted for the Voting phase of the ETSI standards approval procedure.

NOTE: The EBU/ETSI JTC was established in 1990 to co-ordinate the drafting of ETSs in the specific field of broadcasting and related fields. Since 1995 the JTC became a tripartite body by including in the Memorandum of Understanding also CENELEC, which is responsible for the standardization of radio and television receivers. The EBU is a professional association of broadcasting organisations whose work includes the co-ordination of its Members' activities in the technical, legal, programme-making and programme-exchange domains. The EBU has Active Members in about 60 countries in the European Broadcasting Area; its headquarters is in Geneva *.

* European Broadcasting Union
Case Postale 67
CH-1218 GRAND SACONNEX (Geneva)
Switzerland

Tel: +41 22 717 21 11
Fax: +41 22 717 24 81

Proposed transposition dates	
Date of latest announcement of this ETS (doa):	3 months after ETSI publication
Date of latest publication of new National Standard or endorsement of this ETS (dop/e):	6 months after doa
Date of withdrawal of any conflicting National Standard (dow):	6 months after doa

Blank page

1 Scope

This European Telecommunication Standard (ETS) is applicable to 625-line PAL systems B,G,H,I, D and K.

It specifies an enhanced transmission system which allows PAL broadcasters to offer wide-screen pictures in the 16:9 aspect ratio format, maintaining compatibility with existing PAL receivers.

This ETS specifies the transmitted signal. It specifies the method of coding for accommodating wide aspect ratio signals, and the method of coding for reducing conventional PAL cross-effects and for making optimal use of the video signal spectrum. The method for reduction of PAL artefacts may also be used for studio contribution or distribution purposes. Annex C provides details of a reference PALplus decoder that makes full use of the picture enhancements offered by PALplus. Annex F gives rules of operation for the minimum requirements for a PALplus receiver.

2 Normative references

This ETS incorporates by dated and undated reference, provisions from other publications. These normative references are cited at the appropriate places in the text and the publications are listed hereafter. For dated references, subsequent amendments to or revisions of any of these publications apply to this ETS only when incorporated in it by amendment or revision. For undated references the latest edition of the publication referred to applies.

- [1] ITU-R Recommendation BT.601-5: "Studio Encoding Parameters of Digital Television for Standard 4:3 and Wide-screen 16:9 Aspect Ratio".
- [2] ITU-R Recommendation BT.470-4: "Television Systems".
- [3] EBU Technical Recommendation R62: "Recommended dominant field for 625-line 50-Hz video processing".
- [4] ETS 300 294: "Television Systems; 625-Line television Wide Screen Signalling (WSS)".

3 Abbreviations

For the purpose of this ETS, the following abbreviations apply in the construction of system coefficient names:

BB	Black Bands
BPF	Band-Pass Filter
BSPLIT	Band-SPLITing filter
C	Camera mode
CHROM	Modulated PAL CHROMinance
CLIP	CLIPping
CS	motion detector Chrominance Switching control
CVBS	Composite Video, Blanking and Sync
DEC	DECoder
DS	Down-Sampling
ENC	ENCoder
F	Film mode
HDTV	High-Definition TeleVision
IFA	Intra-Frame Averaging
IFD	Inter-Frame Difference
ISS	Inverse Spectrum Shaping
L	motion detector Luminance level control signal
LPF	Low-Pass Filter
LUT	Look-Up Table
M	Motion detector chain chrominance motion signal
MAC	Multiplexed Analogue Components
MACP	Motion Adaptive Colour Plus
MD	Motion Detector chain

NDL	Not incorporating PAL Delay Line function
NYQ	NYQuist
PAL	Phased Alternate Line
POST_MOD	POST-(de)MODulation
PRE_MOD	PRE-(de)MODulation
QMF	Quadrature Mirror Filter
S	motion detector chrominance Switching control signal
SS	Spectrum Shaping
U	present in C_B path
US	Up-Sampling
UV	present in both colour-difference signal (C_B and C_R) paths
V	present in C_R path
VAA	Vertical Anti-Aliasing
VERT	VERTical
VSRC	Vertical Sample-Rate Conversion
Y	luminance signal
YL	motion detector luminance Level control

4 Basic PALplus system description

4.1 Introduction

PALplus is an enhanced transmission system which has been designed to allow PAL broadcasters to offer wide-screen pictures with greatly reduced levels of conventional PAL artefacts, whilst retaining a high level of compatibility with the PAL transmission infrastructure and with existing PAL receivers. The system is intended to co-exist with both MAC and digital television services in a complementary fashion, enabling viewers to receive enhanced quality wide-screen pictures originated in component form. The objective of the PALplus project has not been to design an HDTV system. The expected cost of PALplus receivers is therefore lower than that of HDTV receivers.

The format of the primary input and output signals for PALplus shall be 625/50/2:1, with 16:9 aspect ratio. HDTV 1250/50/2:1 sources can be used after down-conversion to 625/50/2:1.

The wide-screen picture shall be transmitted in letterbox format to achieve compatibility with existing 4:3 receivers. Loss of vertical resolution (as compared to the 576 active line source picture) is minimised in the PALplus receiver by making use of a vertical helper signal transmitted in the black bands above and below the letterbox picture.

The PALplus system has two modes of operation. These are called "film mode", which should be used only with film sources, and "camera mode" which should be used with normal 50 Hz video sources. Both the vertical conversion (to the letterbox picture) and the Motion Adaptive Colour Plus (MACP) method of improved chrominance/luminance separation make use of a camera mode and a film mode to give optimum system performance.

Starting from a 625/50/2:1 4:2:2 digital component input signal (in accordance with ITU-R Recommendation BT.601-5 [1], based on 13,5 MHz sampling) with 576 active lines per frame and an aspect ratio of 16:9, a conversion to 430 active picture lines shall be first carried out.

NOTE: All references to ITU-R Recommendation BT.601-5 [1] refer to the 13,5 MHz sampling rate variant specified in part A thereof.

In "camera mode" (when the source provides 50 Hz motion), this conversion shall be performed intra-field in order to avoid motion artefacts but, in "film mode" (when the source is known to have only 25 Hz motion), then an intra-frame conversion shall be used. The letterbox picture signal used for transmission has only three quarters of the number of active picture lines as the source; in order to minimise loss of vertical resolution in the PALplus display, the black bands shall be used to transmit a vertical helper signal.

An enhanced PAL encoding and decoding technique known as "Motion Adaptive Colour Plus" shall be used to reduce PAL luminance/chrominance cross-talk artefacts and to maximise horizontal resolution. In film mode, the system takes advantage of the known temporal redundancy of the signal and uses an intra-frame PAL encoding technique ("fixed" Colour Plus). In camera mode, the same technique shall be applied to appropriate areas of each picture frame. However, in areas containing moving saturated colour (usually representing only small parts of typical pictures), there is likely to be a significant amount of

movement between the adjacent fields of a source picture frame, which could lead to occasionally visible colour judder if fixed Colour Plus processing were applied. To minimise this problem, in such areas of the picture the system shall revert adaptively to a simpler form of PAL encoding, making use of motion detectors in both the encoder and decoder to identify areas of fast colour motion between adjacent frames.

Ghost cancellation is an optional enhancement. The parameters of the ghost cancellation reference signal are given in ITU-R Recommendation BT.1 124, annex 1, section 1.3.

4.2 Normative features of a PALplus transmission

A PALplus signal shall be derived according to the processes illustrated in figure 1. These are summarised below and detailed descriptions of each process are given in clause 6. The signal at the output of the encoder shall be described as "PALplus" only when all of the following processes are implemented:

- a) Vertical conversion (QMF process) to 430-line letterbox;
 - this is the conversion of the 16:9 aspect ratio source picture with 576 active lines to a 16:9 aspect ratio letterbox picture with 430 active lines. The QMF (Quadrature Mirror Filter) format conversion process also yields vertical luminance resolution information that shall be encoded and transmitted in the black bands.
- b) Vertical helper encoding;
 - this is the method of processing and modulating the vertical luminance information derived from the QMF format conversion process, resulting in the "vertical helper" signal that shall be transmitted in the black bands above and below the active letterbox picture.
- c) Motion Adaptive Colour Plus (MACP);
 - this is the encoding technique that makes possible improved separation of chrominance and luminance in the PALplus receiver.
- d) Wide Screen Signalling (WSS);
 - this shall be used to convey essential information about the content of the transmitted signal to the decoder. The system used is defined in ETS 300 294 [4].
- e) Reference signals;
 - the transmission shall contain reference signals in lines 23 and 623 that may be used by the PALplus receiver for the accurate setting of the levels of the incoming luminance and vertical helper signals. Details are given in subclause 6.5.

The PALplus signal at the output of the encoder shall consist of the combination of the PAL-encoded MACP pre-processed letterbox picture, the modulated helper signal resulting from the QMF conversion process, the reference signals, and the signalling bits, as shown in figure 1.

The features of a PALplus transmission are summarised in table 1. Compensating delays should be included in associated audio paths prior to transmission, so as to match the vision processing time in the PALplus encoder.

Table 1: The enhancement features incorporated in a PALplus transmission

Enhancement	Normative for PALplus?
Format conversion (QMF) from ITU-R Recommendation BT.601-5 [1] source with 16:9 aspect ratio to central 430-line letterbox	YES
Vertical helper encoding	YES
Motion Adaptive Colour Plus	YES
Reference signals (lines 23/623)	YES
Wide Screen Signalling (ETS 300 294 [4])	YES
Ghost cancellation reference signal	OPTIONAL

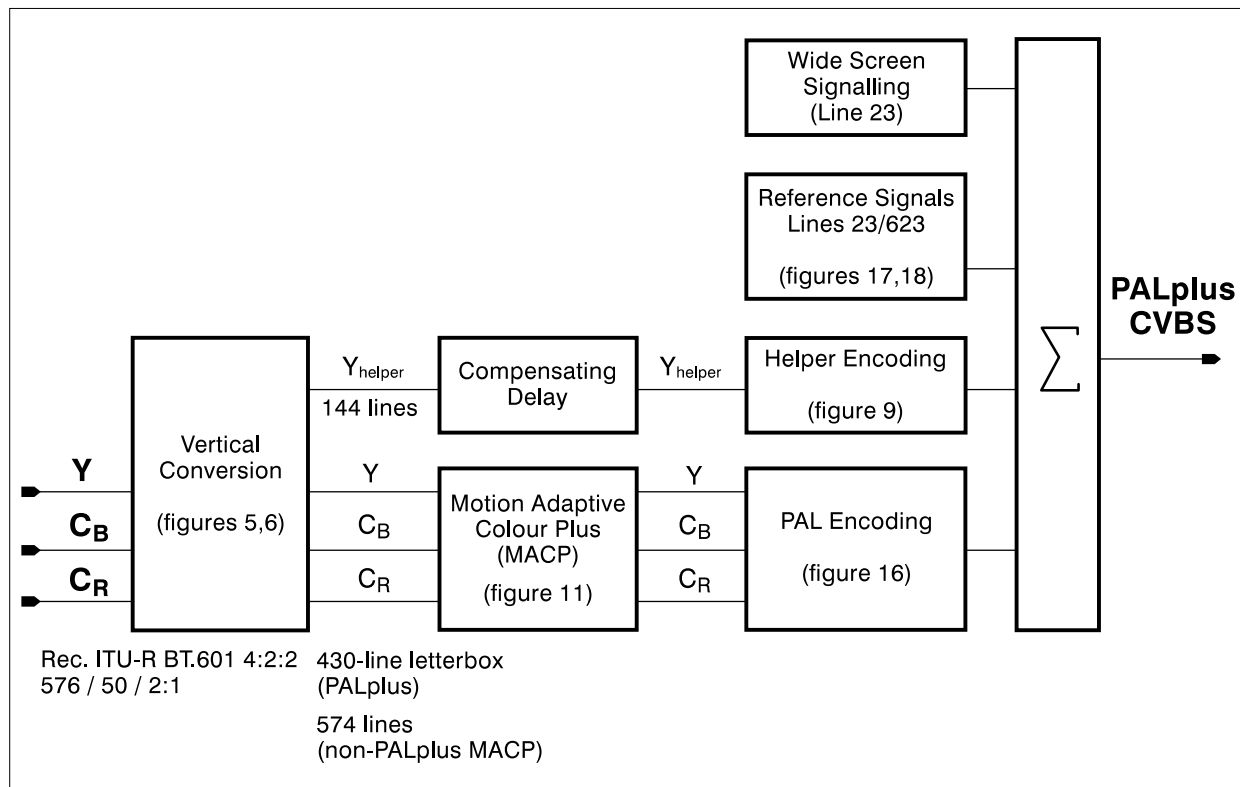

NOTE: Helper not used with non-PALplus MACP.

Figure 1: Outline of PALplus encoding process

5 The PALplus signal

Figure 1 gives a top-level block diagram of the encoding process. All operations are carried out in the digital domain, using line-locked sampling rates of 13,5 MHz, 27 MHz, and 6,75 MHz.

5.1 Input picture signal to the PALplus encoder

The input to the PALplus encoder shall be a component digital 625-line, 50 field/s interlaced 4:2:2 YC_BC_R signal (according to ITU-R Recommendation BT.601-5 [1], minimum 8-bit resolution), with 576 (nominal) active picture lines and an aspect ratio of 16:9. Field 1 shall be the dominant field (see EBU Technical Recommendation R62 [3]) at all times in the case of material to be PALplus encoded in film mode.

5.2 The encoded composite PALplus signal

The output of the PALplus encoder shall be a standard analogue PAL composite signal containing 430 active picture lines in letterbox format, together with helper information contained in the black bands above and below the visible letterbox picture area (see figures 2 and 3). In addition, signalling bits are contained in the first half of Line 23 (see subclause 6.6), and reference signals for use by the PALplus decoder are inserted

into the second half of Line 23 and the first half of Line 623 (see subclause 6.5 and figures 17 and 18). The structure of the PALplus frame is illustrated in figure 3.

All general characteristics of the encoded PALplus signal shall conform to the parameters listed in ITU-R Recommendation BT.470-4 [2]. These include all aspects of the standard PAL colour burst, which shall be retained on the same lines as for a standard PAL signal.

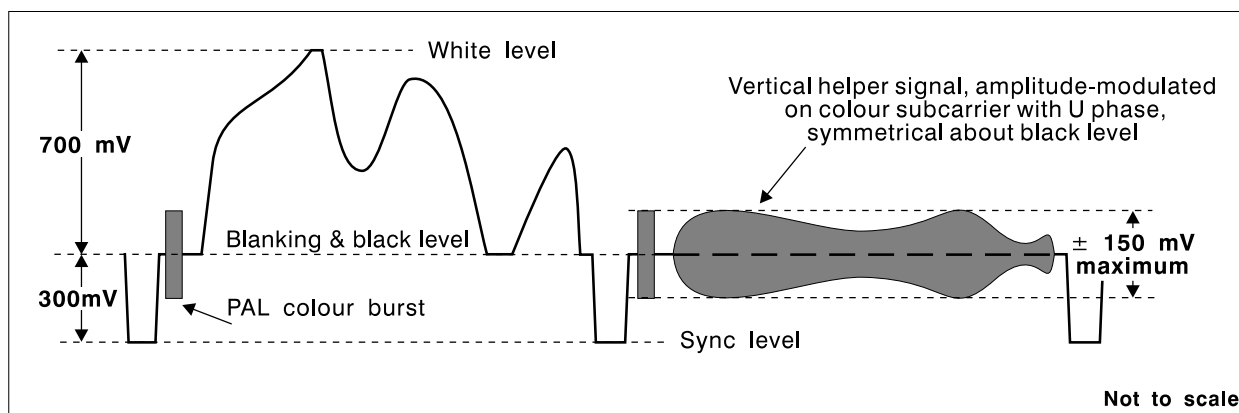

NOTE 1: Standard PAL horizontal blanking shall be applied in lines carrying the vertical helper signal.

NOTE 2: Burst blanking shall be identical to that of a standard PAL signal.

Figure 2: Waveforms showing typical lines of PALplus letterbox and vertical helper signals

All operations in the encoder are performed in digital form. Prior to digital-to-analogue conversion at the output of the encoder, the encoded PALplus signal shall have the following characteristics:

- sampling rate: 13,5 MHz (or multiple thereof), quantizing range: $0,00_{10}$ to $25255,755_{10}$ (unsigned), 10-bit resolution. Black level = $64,00_{10}$, peak-white level = $192,00_{10}$;
- the quantizing range is illustrated in figure 4. The use of 10-bit resolution within this range reduces the effects of quantizing errors in critical areas of processing;
- permitted signal data levels for this 10-bit signal shall be in the range $1,00_{10}$ to $254,75_{10}$ for compatibility with the signal data levels of ITU-R Recommendation BT.601-5 [1]. (All vision signals lie within this range);
- using the above quantizing scale, the maximum peak-to-peak amplitudes of the modulated chrominance signals shall be: $U = 112,00_{10}$, $V = 157,50_{10}$.

NOTE 1: Within this ETS, the contents of digital words are expressed in decimal form. To avoid confusion between 8-bit and 10-bit unsigned representations, the eight most significant bits are considered to be an integer part while the two additional bits, if present, are considered to be fractional parts. (For example, the bit pattern 10 010 001 would be expressed as 145_{10} , and 1 001 000 101 as $145,25_{10}$). Where no fractional part is shown, it is to be assumed to have binary value 00.

Each active line of letterbox picture and of helper shall be formed from 702 digital active samples, and the structure of the PALplus frame shall be as shown in figure 3.

NOTE 2: For convenience, the sampling clock period numbers are indicated in this ETS as being in the range 1 to 864, where clock period 1 represents the leading edge of line syncs, half amplitude reference (see figure 3). Sampling clock period 1 therefore corresponds to ITU-R Recommendation BT.601-5 [1] luminance sample number 732. The first active sample of each line shall be in clock period 143, which corresponds to the 11th sample of the digital active luminance line of ITU-R Recommendation BT.601-5 [1] (luminance sample number 10).

The frequency spectrum occupied by the chrominance signal shall be $4,43 \text{ MHz} \pm 1,3 \text{ MHz}$ at -3 dB.

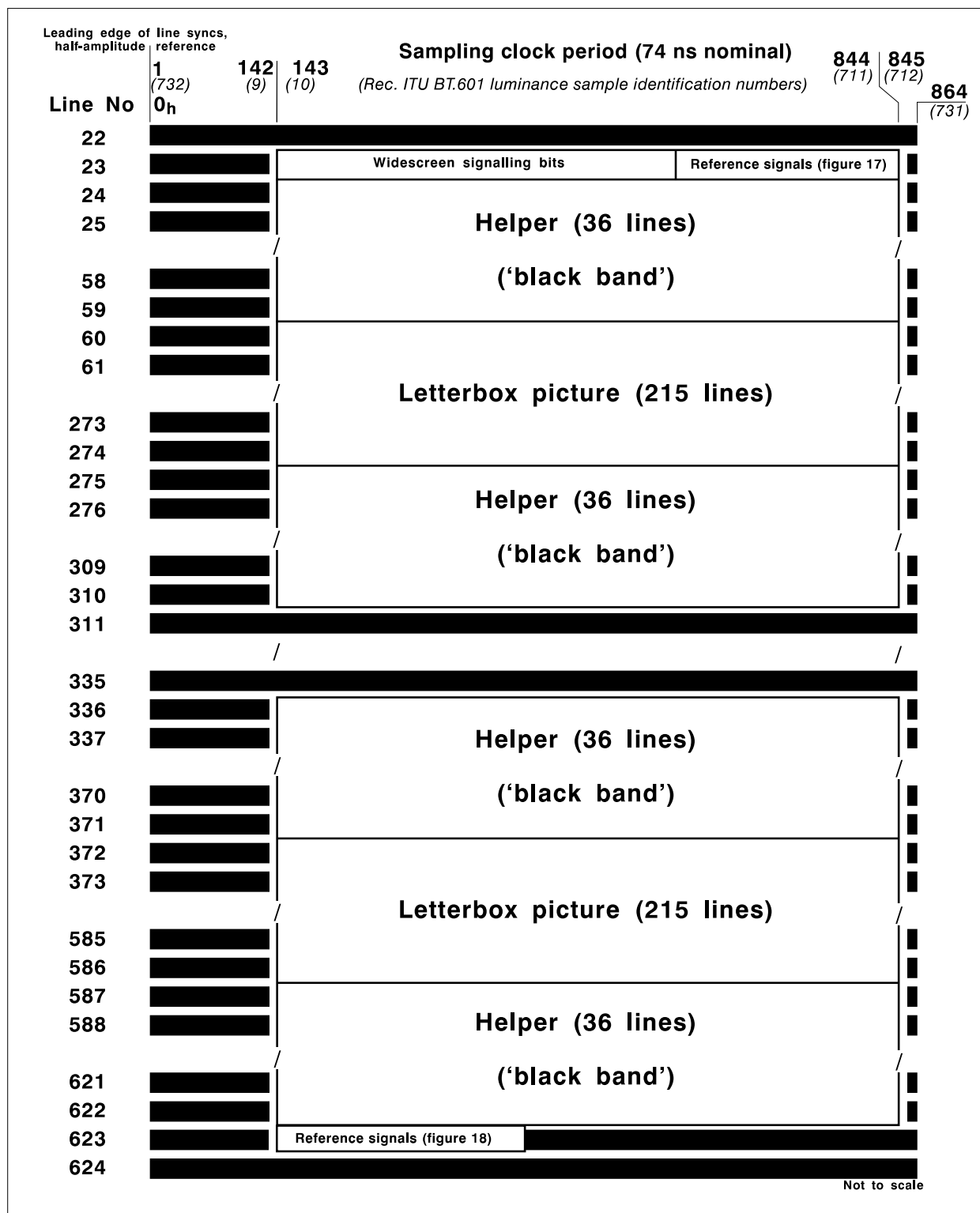

NOTE 1: Sampling clock periods correspond to those of ITU-R Recommendation BT.601-5 [1] (sampling frequency: 13,5 MHz) as indicated above.

NOTE 2: Active lines contain 702 samples for letterbox picture or helper.

Figure 3: Structure of the PALplus frame

The amplitude/frequency characteristic of the luminance signal shall be substantially uniform from 0 to 5,5 MHz. The horizontal bandwidth of the luminance signal shall be limited principally by the use of digital processing with 13,5 MHz sampling according to ITU-R Recommendation BT.601-5 [1] and, unlike standard PAL encoding, may not be modified by the use of a notch filter in the region embracing the subcarrier frequency.

The transmitted luminance and chrominance bandwidths may be restricted by the characteristics of the transmission system; for example, the luminance bandwidth will be limited to 5 MHz in the case of System B/G, and to 5,5 MHz in System I (see ITU-R Recommendation BT.470-4 [2]).

The total delay in the encoding process shall preferably be the same in both camera mode and in film mode. The exact delay will depend on the encoder implementation, but might in practice be expected to be of the order of 30 ms. An equivalent compensating delay should be applied to associated audio paths prior to transmission.

NOTE: Time delay in encoder: the modular description of the encoding processes will result in a longer time delay than this. Although it is possible to combine some elements so as to reduce the time delay, a fully modular approach to the description of the formation of a PALplus signal has been adopted for reasons of clarity.

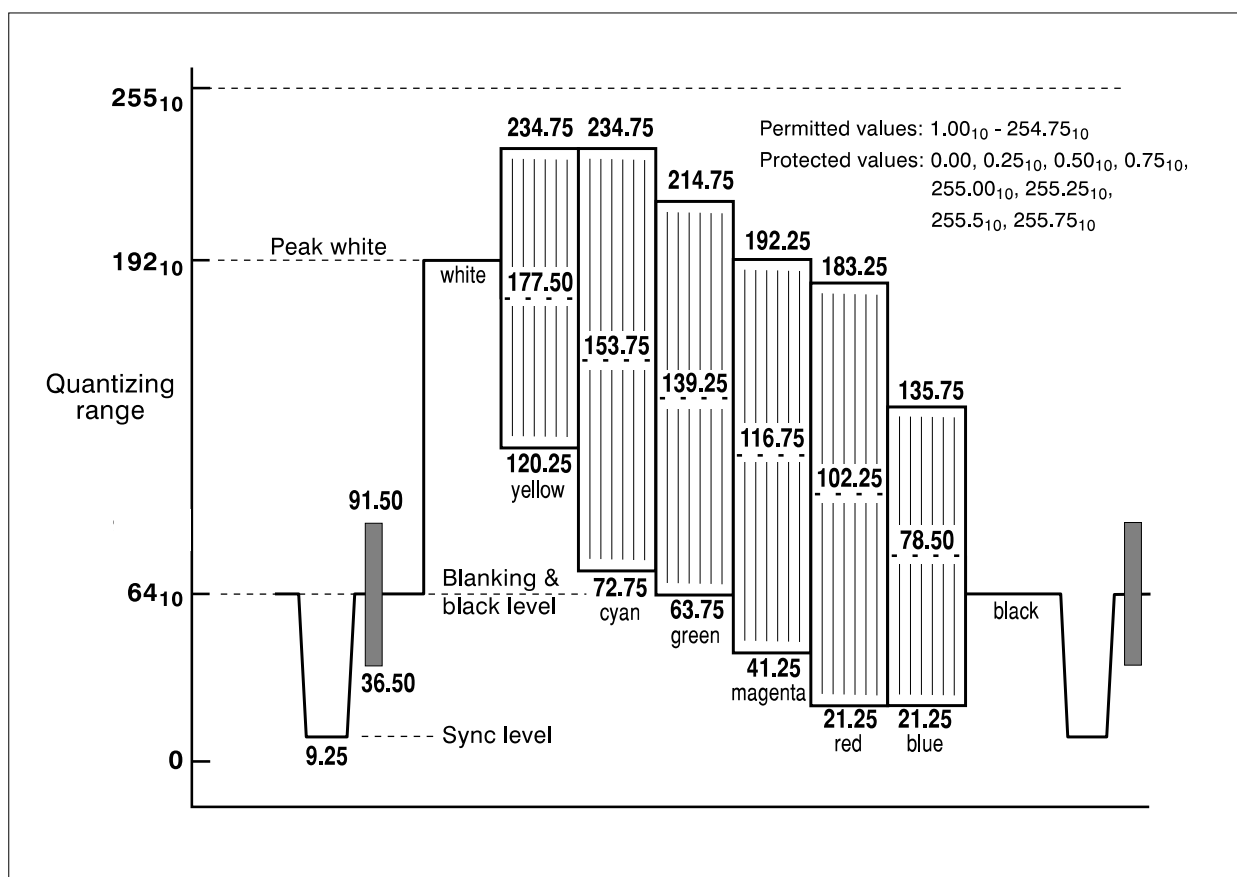

NOTE: Nominal values are shown for the line waveform for 100 % amplitude, 100 % saturation colour bars. The signal shall be coded with 10-bit resolution.

Figure 4: Digital representation of the PALplus signal, showing the quantization ranges

6 The PALplus encoding processes

This clause describes in greater detail the operation of each of the processing blocks in the encoder (see figure 1). Filter and look-up table coefficients shall be as specified in annex A.

Starting at the input of the PALplus encoder, the Vertical Conversion processing block (see figure 5 for the case of camera mode, and figure 6 for film mode) produces a $Y_C B_C R_C$ signal with 430 active picture lines, together with a helper signal representing additional vertical resolution contained in the 576-active line source picture.

The Helper Encoding block (see figure 9) processes the vertical helper signal, modulating it onto a carrier of PAL colour subcarrier frequency, for insertion into the black bands above and below the letterbox picture. A delay precedes this block (or may be incorporated within it) to compensate for the delay within the Motion Adaptive Colour Plus process.

The Motion Adaptive Colour Plus block (see figure 11) carries out pre-processing to enable subsequent separation of luminance and chrominance with greatly reduced levels of conventional PAL artefacts (cross-colour and cross-luminance) with appropriate post-processing in the decoder. The pre-processing in the encoder shall be performed on the 430-active line $Y_{C_B C_R}$ signal supplied by the Vertical Conversion process.

The Motion Adaptive Colour Plus pre-processed 430-active line $Y_{C_B C_R}$ signal shall be then PAL encoded (see figure 16).

The PALplus signal at the output of the encoder consists of the combination of the PAL-encoded MACP pre-processed letterbox picture, the modulated helper signal resulting from the QMF conversion process, reference signals in lines 23 and 623, and the Line 23 Wide Screen Signalling information, as shown in figure 1.

6.1 Vertical conversion

The incoming 576-active line $Y_{C_B C_R}$ signals shall be converted to a central 430-line letterbox picture, together with 144 lines of a vertical helper signal representing luminance vertical information. The conversion shall be carried out intra-frame in film mode, and shall be carried out intra-field in camera mode, as specified in annex A, clause A.2.

The entire contents of lines 23 and 623 of the input signals to the encoder shall be set to black, overwriting any active video in the half-lines, before entering the encoder luminance QMF and chrominance vertical sample rate conversion blocks. (Y shall be set to 16_{10} , and C_B/C_R to 128_{10}).

In film mode, field memories M4A (luminance) and M5A (C_B, C_R) together with the associated line memories (M4B for luminance, M5B for C_B, C_R) and switches perform field insertion during the second input field (see figure 6). This results in a sequential frame for processing at the rate of 27 MHz for luminance, and 13,5 MHz for each of C_B and C_R .

6.1.1 Encoder vertical conversion of luminance

For luminance, a special Quadrature Mirror Filter (QMF) technique shall be used to generate two sub-bands: the 430-line letterbox luminance, and 144 lines representing the vertical detail information that would otherwise be lost by the vertical filtering to 430 lines (see figure 7). The QMF technique used shall be essentially loss-free, and has the advantage that in the decoder there will be cancellation of alias components in the main and helper signals.

The luminance QMF (ENC_Y_QMF) operates at 13,5 MHz in camera mode, and at 27 MHz in film mode (during the period of one field only), while for chrominance the sample rate conversion takes place at 6,75 MHz in camera mode and 13,5 MHz in film mode. In film mode, memories M1, M2, M3, M4 and M5 are used to change sample rates from the input/output rates to the double speed used in the luminance QMF and chrominance vertical sample rate conversion processes.

Following the QMF, some further memories and field-rate switches are required. This is because although the filters and the QMF have produced the correct number of lines for the letterbox signal, these lines are in the form of a multiplex of letterbox picture and helper lines (three lines of letterbox picture followed by one line of helper) spread out across the period of the input field (camera mode) or frame (film mode). Referring to figures 5 and 6, M2A and M2B store the two fields of each letterbox luminance frame. M3A and M3B hold the first and second fields of the colour-difference signals. M1A and M1B perform a similar function for the helper lines, storing them as they are output from the QMF. The frame memory sizes shown in figure 5 for M1A, M2A and M3A ensure that the camera mode processing time delay is identical to that of film mode.

6.1.2 Encoder vertical conversion of chrominance

The colour-difference signals undergo vertical sample rate conversion to produce a 430-line picture signal, carried out intra-field in camera mode, and intra-frame in film mode, by a bank of filters operating in parallel.

In film mode, vertical filter ENC_UV_F_VSRC generates 215 lines of intra-frame averaged colour difference signal by a single intra-frame down-conversion operation. The output from the vertical filter ENC_UV_F_VSRC shall be a single field of film mode colour-difference signal. In field memories M3A and M3B, the colour difference signal shall be stored with $64\mu\text{s}$ output lines in the two successive fields of the output frame. This ensures that the colour-difference signal in the two fields is identical.

Camera mode colour-difference signals are converted by vertical filter ENC_UV_C_VSRC. The coefficients are arranged to provide separate conversion of each field.

There is no attempt to convey additional vertical chrominance resolution to the receiver as there is in the case of luminance (representing the lost vertical resolution arising from the format conversion to 430 lines). Even without such a helper signal, the colour vertical resolution is already much higher than the colour horizontal resolution.

6.1.3 430-line letterbox

A complication arises because in PAL the transmitted 625-line signal does not contain 576 complete active lines. There are only 574 full active lines, with lines 23 and 623 containing only half lines. Application of the Motion Adaptive Colour Plus encoding technique requires averaging of picture information between pairs of adjacent lines within the frame. There are no corresponding "partner" picture lines for half-lines at the start and end of a frame, and it would be pointless to generate half-lines of letterbox picture in the vertical conversion process.

The entire contents of lines 23 and 623 of the input signals to the encoder are therefore set to black, overwriting any active video in the half-lines, before entering the encoder luminance QMF and chrominance vertical sample rate conversion blocks. (Y shall be set to 16_{10} , and C_B/C_R to 128_{10}).

The encoder luminance QMF and chrominance vertical sample rate conversion processes can give outputs with 216 picture lines per field. However, the first resulting picture line of the odd field and the last line of the even field would not contain useful picture information, so if produced these should not be stored in the subsequent letterbox picture memories (M2 and M3), each of which holds only 215 lines per field.

The result of the vertical conversion process shall be a letterbox picture with 430 full picture lines per frame, suitable for subsequent Motion Adaptive Colour Plus encoding and decoding.

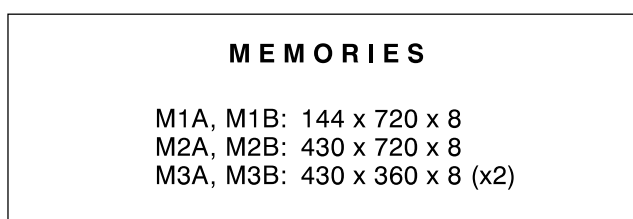
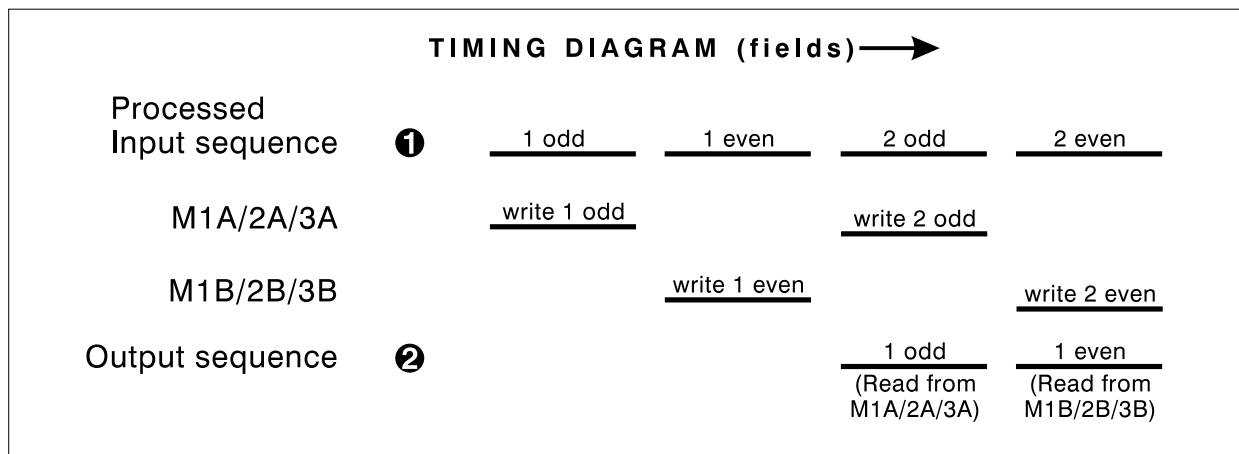
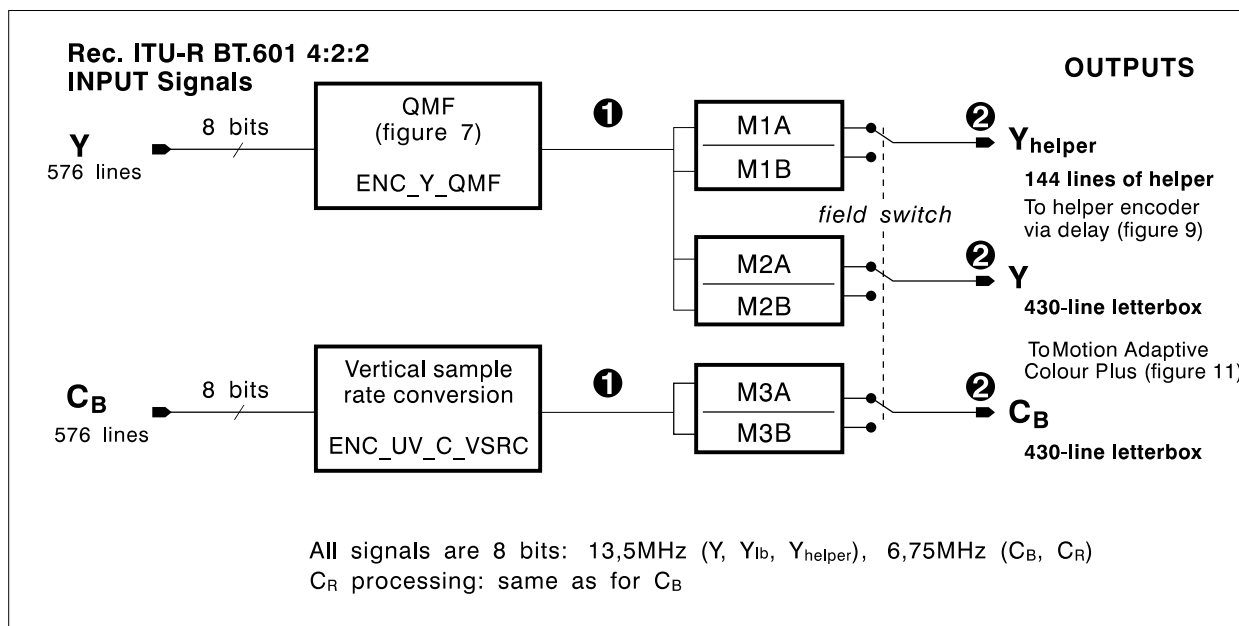
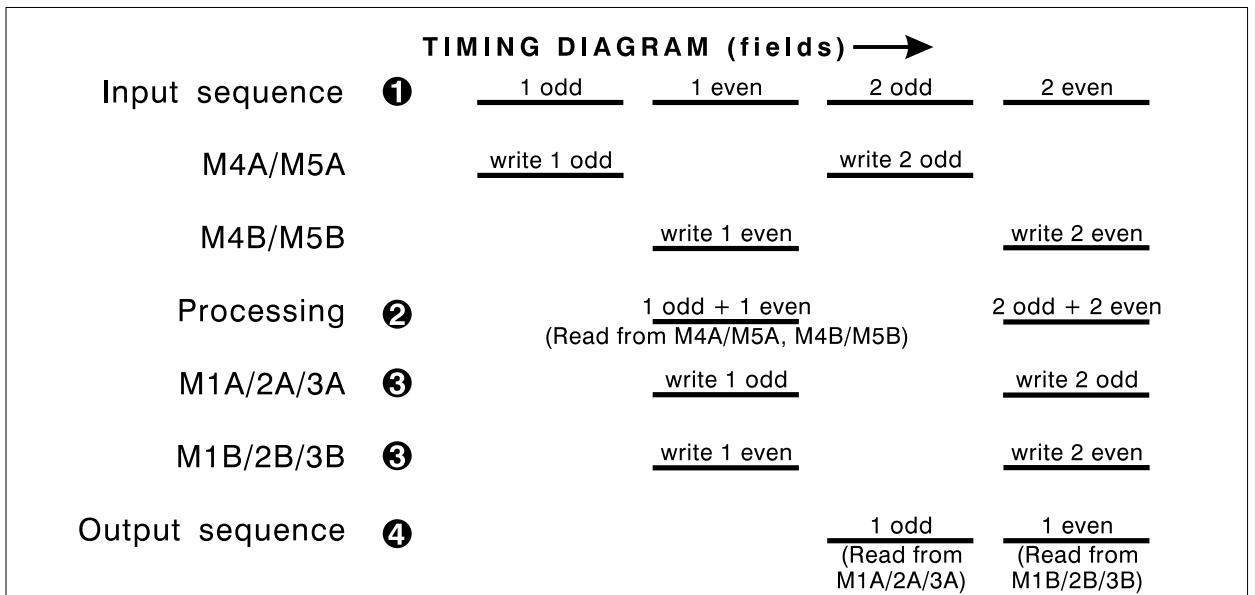
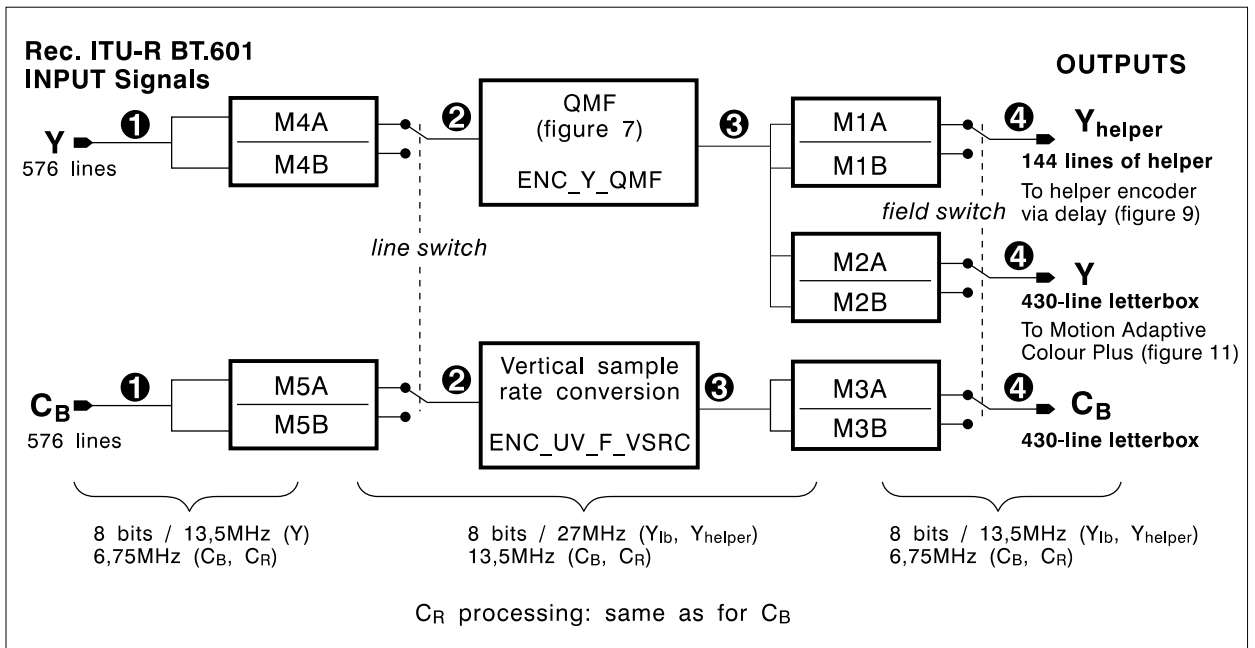

Figure 5: Encoder vertical conversion (camera mode)



MEMORIES

M4A: 288 x 720 x 8	M4B: 1 x 720 x 8
M5A: 288 x 360 x 8 (x2)	M5B: 1 x 360 x 8 (x2)
M1A: 72 x 720 x 8	M1B: 144 x 720 x 8
M2A: 215 x 720 x 8	M2B: 430 x 720 x 8
M3A: 215 x 360 x 8 (x2)	M3B: 430 x 360 x 8 (x2)

6-021

Figure 6: Encoder vertical conversion (film mode)

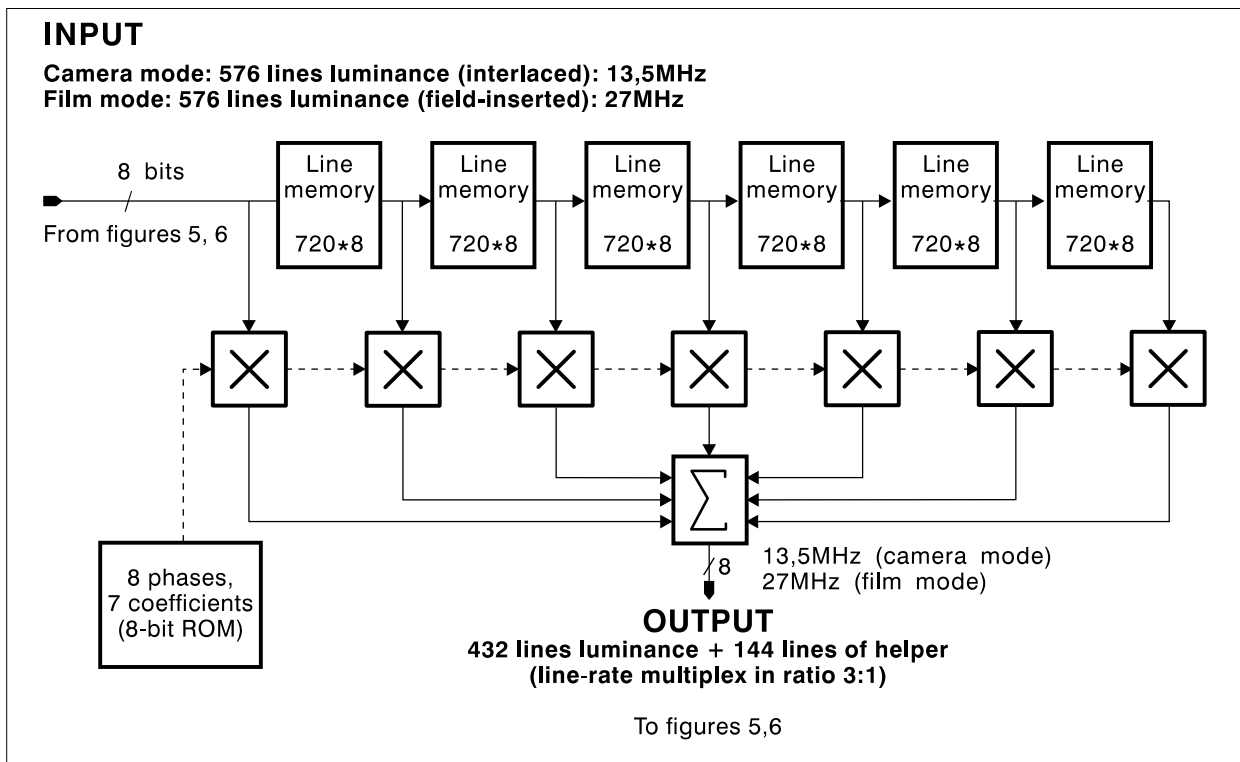

NOTE: Output lines have mid-grey set-up of 128₁₀.

Figure 7: Encoder QMF (ENC_Y_QMF)

6.2 Vertical helper encoding

The vertical helper signal in the black bands shall be transmitted symmetrically around black level, with a maximum amplitude of 300 mV peak-to-peak, the same as that of the colour subcarrier burst. The vertical helper shall be modulated onto the colour subcarrier frequency in order to ensure the absence of low frequency content in the transmitted signal. This modulation has the additional advantage of reducing the visibility on the compatible receiver. Distortion is also avoided which, in certain types of transmitter, might otherwise occur with low-frequency higher amplitude signals in the ultra black region.

6.2.1 Helper amplitude

The reduction in amplitude of the information transmitted during the black bands causes a noise penalty for the PALplus receiver. This noise penalty would be unacceptable if no special measures were taken to reduce it. A combination of clipping, coring and non-linear amplitude companding shall be applied, thereby greatly reducing the noise penalty.

6.2.2 Modulation

The information to be transmitted during the black bands shall be free of low frequency information. This is achieved by using vestigial side-band suppressed carrier amplitude modulation. Since there is no need to transmit chrominance picture information in the black bands, the colour subcarrier can conveniently be used as the carrier. Modulation shall take place on the U phase of the colour subcarrier, to minimise visibility on conventional PAL receivers.

Following modulation, the helper shall undergo full Nyquist filtering (-6 dB at f_{sc}). This has a benefit in terms of ease of implementation in the decoder, compared to half-Nyquist decoder filtering. Instead, the "brick-wall" slope of the receiver IF SAW filter may be employed to provide the correct receiver filtering.

The modulation scheme has been optimised for conventional terrestrial transmission, which uses vestigial side-band amplitude modulation of the vision signal. A "shaped" full Nyquist filtering system shall be used in order to help minimise the visibility of the helper signal on the compatible picture. This is achieved by a shaping filter prior to modulation which attenuates the higher helper baseband frequencies by 3 dB. An inverse shaping filter shall be incorporated in the decoder. The approximate spectral occupancy of the transmitted helper signal is shown in figure 8, which shows the maximum possible amplitude versus frequency.

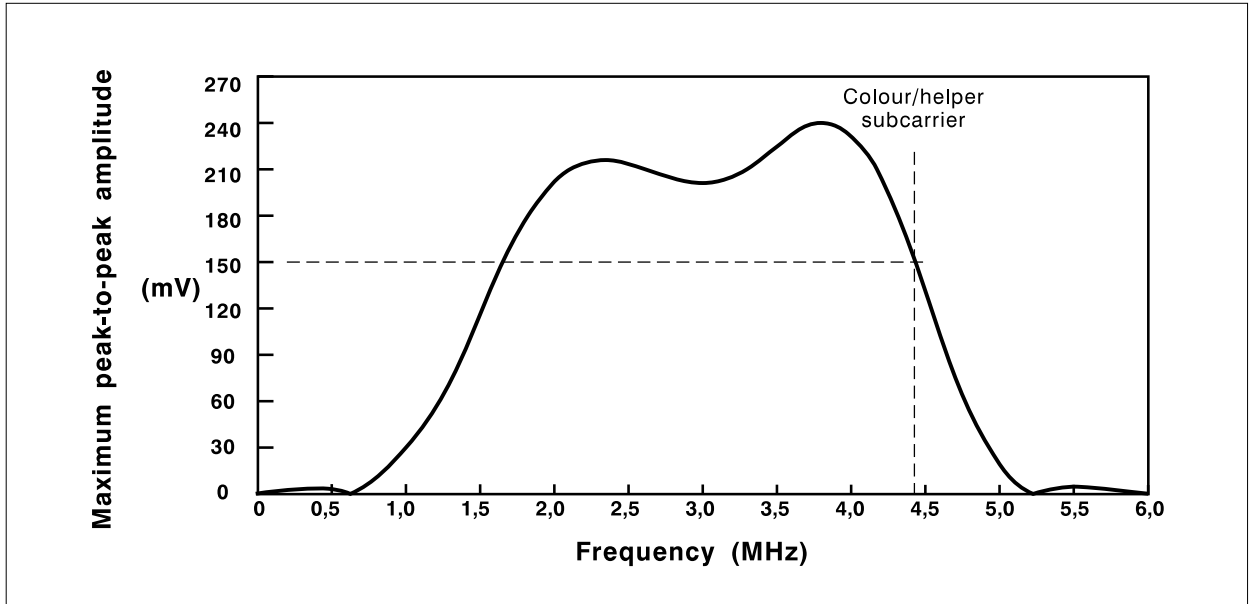

NOTE: Maximum permissible time-domain helper amplitude shall be 300 mV peak-to-peak.

Figure 8: The frequency spectrum occupied by the modulated helper signal

6.2.3 Description of helper processing

All helper processing in the encoder shall be performed at 27 MHz (see figure 9), since this is advantageous in minimizing alias products, and shall use the filter and look-up table coefficients specified in annex A, clause A.3.

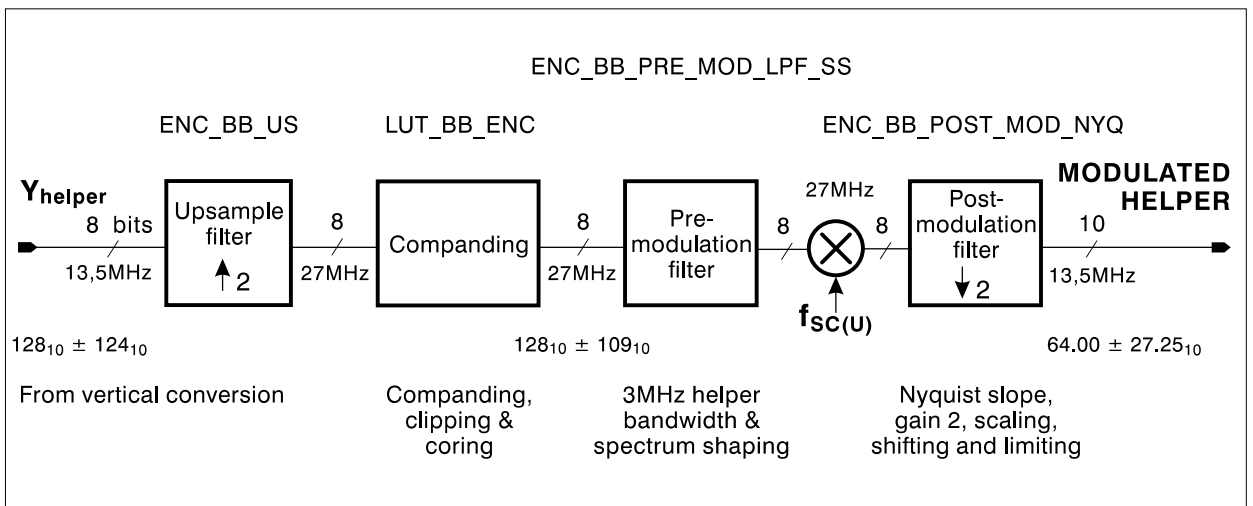

Figure 9: Helper encoding

The helper signal shall be first up-sampled to 27 MHz by filter ENC_BB_US.

LUT_BB_ENC performs the companding process. The effects of noise on the helper in film mode are reduced by the incorporation of a gain factor of two compared to the companding in camera mode. Figure 10 illustrates the process. The companding curves are shown in figure 10(a). The result is that in film mode the point of clipping is reached for input signals of lower amplitude, but in practice it is found that the vast majority of picture sources result in a helper with sufficiently low amplitude such that clipping does not occur.

The following scaleable formula shall be used to derive values for the compander look-up table LUT_BB_ENC given in annex A:

$$\begin{aligned}
 & \text{IF } x \leq 0,04 * X_{range} \text{ THEN } y' = 0 \\
 & \text{IF } x > 0,04 * X_{range} \text{ THEN } y' = Y_{range} * \frac{\left[\frac{x}{X_{range}} + p^3 \right]^{p^1}}{p^4 + p^3} - p^2 \\
 & y = \text{MIN} [y' * \text{AmplFactor}, Y_{range}]
 \end{aligned}$$

where:

- x is the absolute non-companded value and y is the absolute companded value;
- $p^1 = 0,0010$; $p^2 = 0,9977126$; $p^3 = 0,07477$; $p^4 = 0,79981$;
- $\text{AmplFactor} = 1$ (camera mode), $\text{AmplFactor} = 2$ (film mode);
- the ranges are indicated with X_{range} and Y_{range} (both are 109).

NOTE 1: The DC-shift (128_{10}) is not included in the formula.

NOTE 2: The companding curve is symmetrical about zero, such that negative values for x and y are derived directly from the absolute values provided by the formula.

The pre-modulation filter ENC_BB_PRE_MOD_LPF_SS removes higher harmonics caused by companding, determines the helper bandwidth, and also provides the spectrum shaping referred to in subclause 6.2.2. Modulation shall take place using the U-phase of the colour subcarrier (sampled at 27 MHz), and shall be followed by the post-modulation filter ENC_BB_POST_MOD_NYQ which includes full Nyquist filtering and down-sampling to 13,5 MHz.

Pre-modulation filter ENC_BB_PRE_MOD_LPF_SS shall be the dominant filter in determining helper bandwidth. This bandwidth has been chosen to match the low-pass characteristic of the Colour Plus luminance band-splitting filter (Y_BSPLIT); such a match has been found to give the best results.

The 8-bit luminance signal at the input to the QMF circuit is within the range 0 to 255_{10} . The QMF coefficients that are used to create the helper signal can be regarded as a filter with a maximum gain of $\pm 124/128$. Therefore, the signal range of the 8-bit helper at the output of the QMF circuit (and at the input to the helper signal encoding block) is $128_{10} \pm 124_{10}$ (symmetric because it is a DC-free signal). The effect of companding shall be to limit the range to $128_{10} \pm 109_{10}$.

Before modulation, the set-up (128_{10}) shall be subtracted and the range becomes -109_{10} to $+109_{10}$, which levels are used during modulation and filter ENC_BB_POST_MOD_NYQ. Most of the helper signal processes of figure 9 have a gain of 1 at low baseband helper frequencies, so that the 8-bit output range shall be thus also $128 \pm 109_{10}$; the only exception is the post-modulation filter ENC_BB_POST_MOD_NYQ which performs full Nyquist filtering: following this filter, a gain of 2 shall be included to restore the maximum peak-to-peak amplitude to the same range of $\pm 109_{10}$.

Finally, a scaling block shall be added to bring this range (-109_{10} to $+109_{10}$) to the desired output range representing -150 mV to $+150$ mV for subsequent addition to the composite video signal. The output range should be less than $150/700 * (192_{10}-64_{10}) = 27,43_{10}$, so that, in 10-bit form, limiting to $64,00_{10} \pm 27,25_{10}$ will ensure that the limit of ± 150 mV shall not be exceeded.

NOTE: The encoder helper processing is defined as using 8-bit signal paths. The scaleable formula for the companding process may be used to provide values appropriate for signal paths with higher precision, if required.

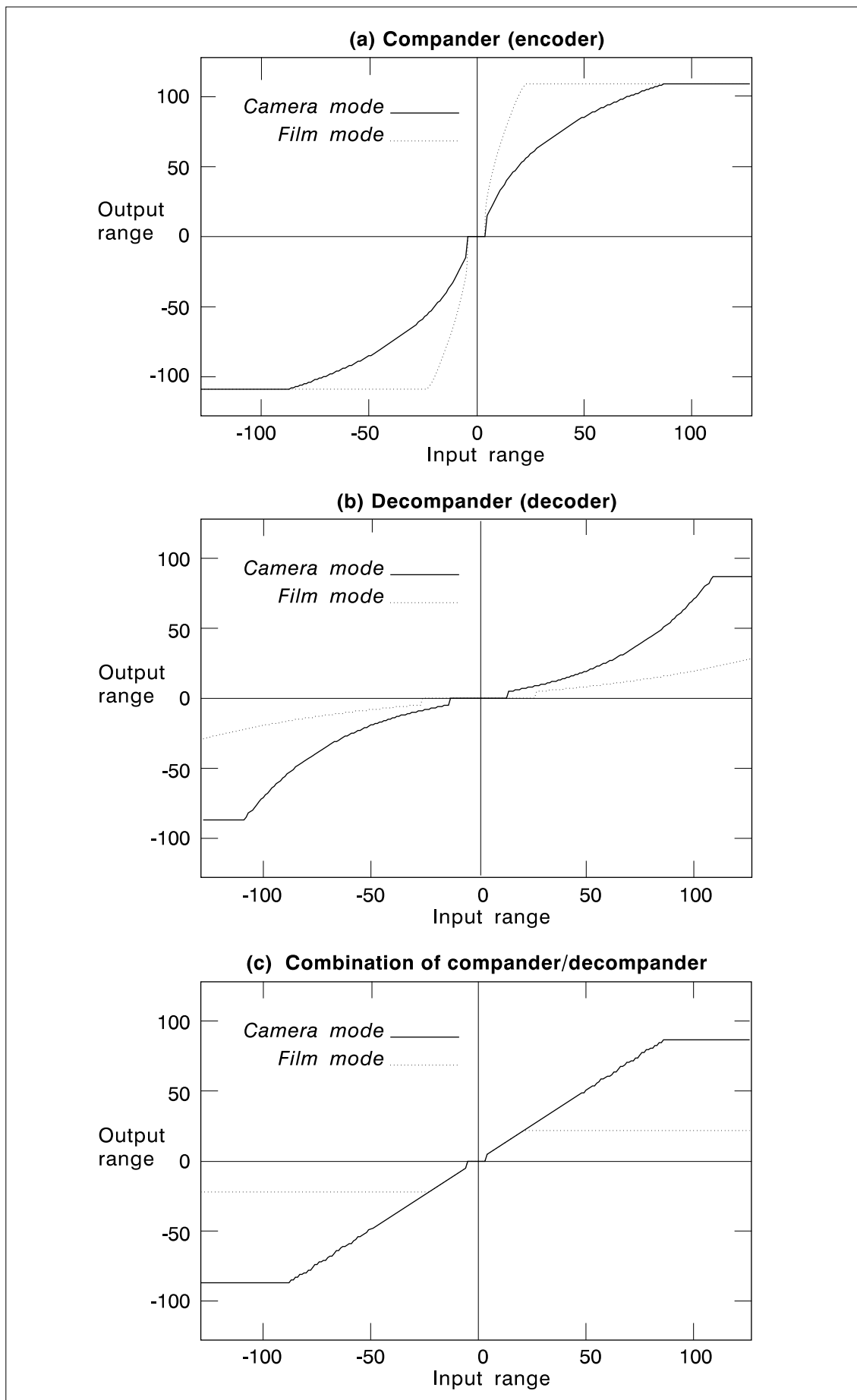

Figure 10: Illustration of the helper companding process

6.2.4 Baseband helper

Special forms of PALplus for studio, distribution or other non-broadcast applications can exist in which the helper signal remains unmodulated, in baseband, centred on mid-grey. The helper may be taken direct from the vertical conversion process described in subclause 6.1, or could be in companded form. In both cases, the helper would be visible and would not be transmitted in this way. Accurate settings of helper DC-level and gain would be essential for correct decoder reconstruction. In analogue form, it would be necessary to use modified reference signals (see subclause 6.5.1).

6.3 Motion Adaptive Colour Plus

The enhanced PAL encoding and decoding processes used in PALplus have been designed to cause minimal cross effects between luminance and chrominance at the output of the PALplus decoder. The technique is known as "Motion Adaptive Colour Plus". It encompasses the "fixed" Colour Plus processing that shall be used in film mode only, and enables the benefits of Colour Plus processing to be obtained over most areas of pictures in camera mode.

"Fixed" Colour Plus uses the fact that points in a PAL signal separated by exactly 312 lines have almost exactly opposite subcarrier phase. Considering a line, say "n", in the first field, then the line $n+312$ shall be the line in the second field which is immediately above line n in the frame. If these two lines carry the same luminance and chrominance information, the luminance and chrominance can be separated by adding and subtracting the composite signals from each other. Adding yields luminance because the anti-phase colour subcarrier cancels. Subtracting yields modulated chrominance because the anti-phase colour subcarrier adds and the luminance cancels. C_B and C_R colour-difference signals free from cross-effects may alternatively be recovered by intra-frame averaging following chrominance demodulation. It is this latter approach that is the preferred method of implementation for the PALplus decoder.

In practice, only high horizontal frequency luminance (above approximately 3 MHz) shall be intra-frame averaged, because only this part of the luminance signal shares spectrum with the modulated chrominance.

"Fixed" Colour Plus works well in film mode. However, simply averaging samples 312 lines apart would occasionally cause unacceptable artefacts in camera mode, where there may be some movement between adjacent fields of a frame. A particular problem can occur in fast moving coloured areas: since all of the chrominance signal is averaged, motion artefacts are sometimes visible in the form of colour judder. In camera mode, therefore, Motion Adaptive Colour Plus shall be used, in which a motion detector in both the encoder and decoder detects movement in the chrominance signal.

The output of the motion detector shall be a control signal which selects between "fixed" Colour Plus encoding and decoding, and conventional colour encoding and decoding using only low-frequency luminance (up to 3 MHz). In areas of saturated moving colour, the spectrum of the encoded PALplus signal above 3 MHz shall be occupied solely by chrominance, with no vertical or temporal constraints.

The motion detector in the decoder shall track the motion detector in the encoder, and should therefore use the same form of input signal. This is chosen to be an intra-frame-averaged chrominance signal, as such a signal can be generated in the decoder to match this signal generated in the encoder, independent of the amount of motion detected in the encoder; this guarantees that encoder and decoder motion signals will be identical. The frame difference of this intra-frame averaged chrominance signal shall be used to detect motion.

In film mode, there is no need for the motion adaptive processing, and the colour encoding and decoding processes remain in "fixed" Colour Plus.

6.3.1 Pre-processing in the encoder

The encoder luminance processing is shown in figure 11(a).

The luminance shall be divided into high and low frequency components Y_{HF} and Y_{LF} respectively by the horizontal filter Y_BSPLIT and the associated subtractor. (An identical filter to this is used in the reference decoder, see annex C, figure C.6).

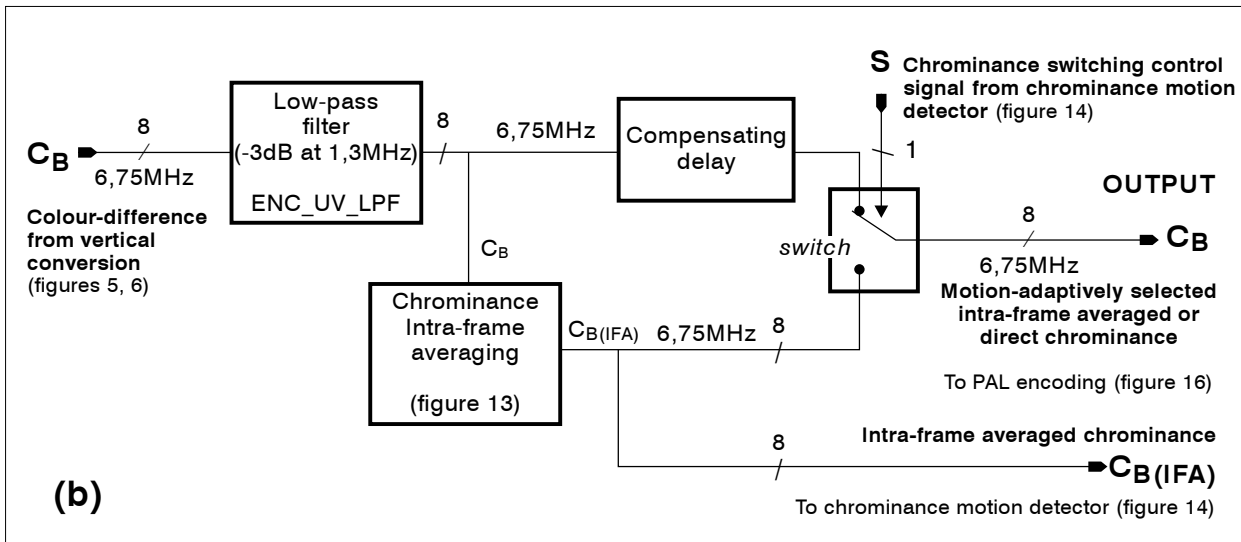
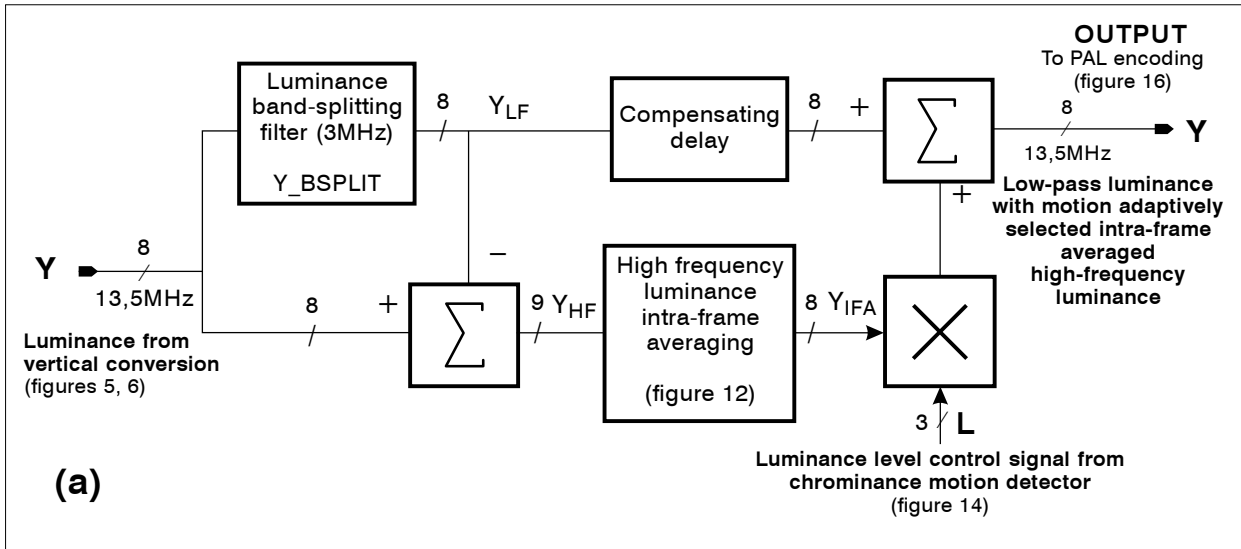

11-032

NOTE: Processing of C_R shall be identical to that of C_B .

Figure 11: Motion Adaptive Colour Plus encoding of (a) luminance and (b) chrominance

The high pass signal Y_{HF} shall undergo vertical pre-filtering and intra-frame averaged as defined by the vertical filter ENC_Y_IFA (see figure 12). The amplitude of the resulting signal Y_{IFA} shall be adjusted by the luminance control signal L (see subclause 6.3.2) and then added back to the low frequency component Y_{LF} . The intra-frame averaged high frequency component shall be at full amplitude in film mode or stationary areas of camera mode, but shall be reduced in areas of colour motion in camera mode.

The chrominance processing is shown in figure 11(b).

Chrominance pre-filtering is necessary for Motion Adaptive Colour Plus in order to provide sufficient attenuation of colour-difference frequencies higher than about 1,4 MHz.

The C_B/C_R low pass filter ENC_UV_LPF shall be designed to have as wide a bandwidth as possible, without introducing unacceptable levels of cross-luminance. This means that very little chrominance energy should be allowed below 3 MHz in the PAL encoded signal. This in turn implies that the filter should have good suppression of chrominance frequencies above 1,4 MHz. This is because of interaction with the effects of the luminance band-splitting filter Y_BSPLIT which separates high-frequency luminance above approximately 3 MHz for intra-frame averaging.

Greater attenuation of high colour-difference frequencies is required than the minimum needed to comply with the normal PAL specification (ITU-R Recommendation BT.470-4 [2]) so as to avoid the introduction of unacceptable cross-luminance artefacts in the PALplus receiver.

The horizontal bandwidths of the colour-difference signals prior to intra-frame averaging shall therefore be constrained by the following conditions:

attenuation relative to low frequencies:

- ≤ 3 dB at 1,3 MHz;
- ≥ 6 dB at 1,6 MHz;
- ≥ 30 dB at 2,4 MHz;

the step response of the pre-filtering shall result in:

- first overshoot < 6 %;
- first undershoot < 2 %.

The frequency spectrum occupied by the chrominance signal at the output of the PALplus encoder shall be $4,43 \text{ MHz} \pm 1,3 \text{ MHz}$ at -3 dB, to comply with ITU-T Recommendation BT.470 -4 [2].

The coefficients of the recommended encoder chrominance pre-filter ENC_UV_LPF are given in annex A, and were selected during the course of tests with reference hardware. This has been shown to give a good balance between chrominance bandwidth and suppression of PAL artefacts, while introducing minimal ringing.

The C_B/C_R signals are divided into two paths: a direct path (with compensating delay) and an intra-frame averaged (IFA) signal (see figure 13)). The IFA signal is also sent to the motion detector (see figure 14). A control signal S derived from the motion detector (see subclause 6.3.2) selects the output of either direct or intra-frame averaged C_B/C_R signals. In film mode or in stationary areas of camera mode, intra-frame-averaged C_B/C_R signals are selected; in camera mode, the direct C_B/C_R signals are selected in areas of the picture containing saturated colour motion, in order to avoid colour judder.

In PALplus, the Motion Adaptive Colour Plus process shall be carried out on the 430-line letterbox picture (see figure 3). Motion Adaptive Colour Plus may be applied to other ITU-R Recommendation BT.601-5 [1] input sources, see subclause 6.3.4.

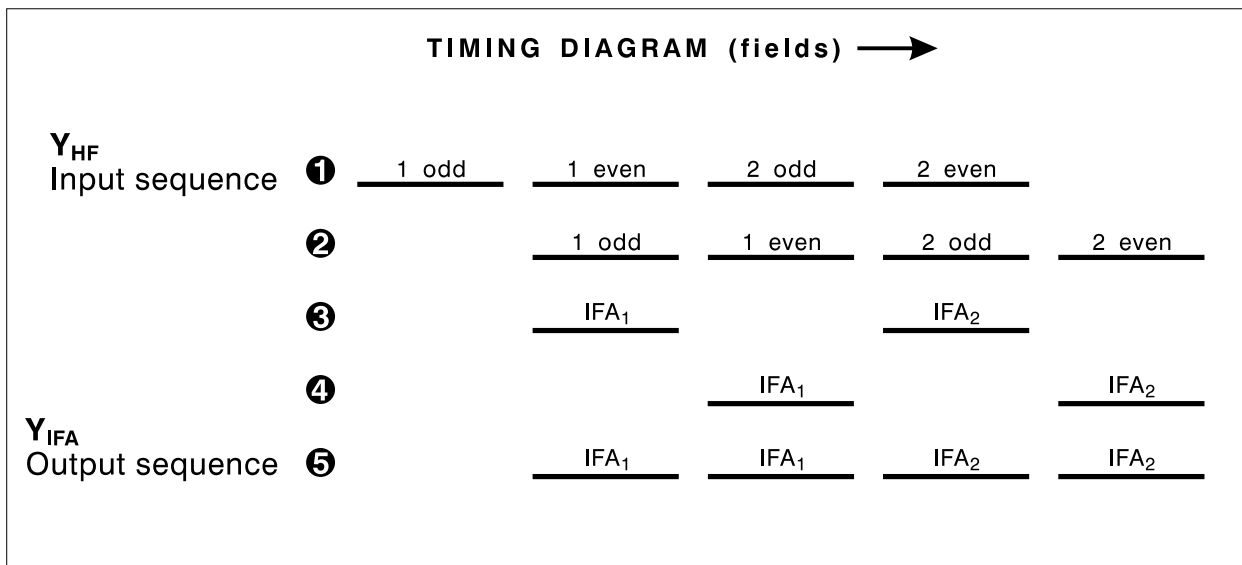
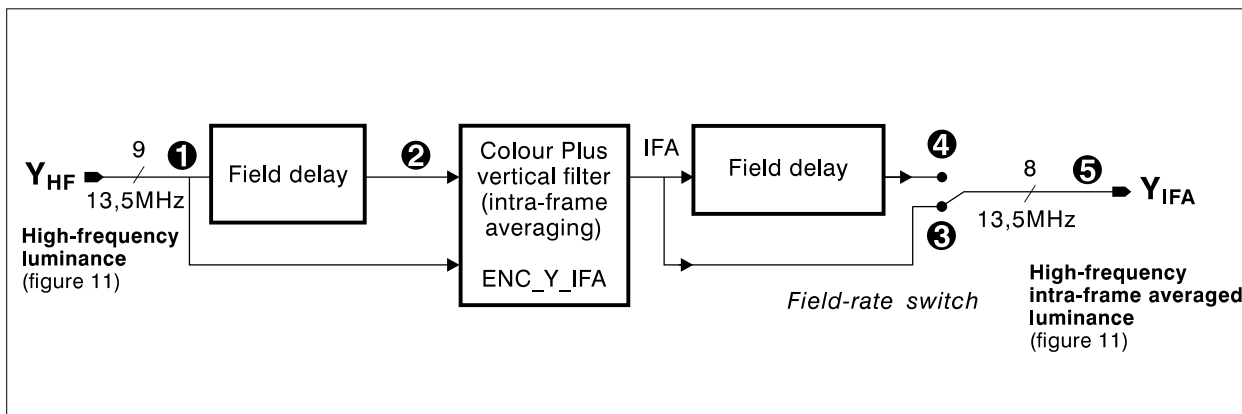

NOTE: IFA_n = field of intra-frame averaged signal averaged from odd and even fields of frame n.

Figure 12: Motion Adaptive Colour Plus intra-frame averaging of high-frequency luminance

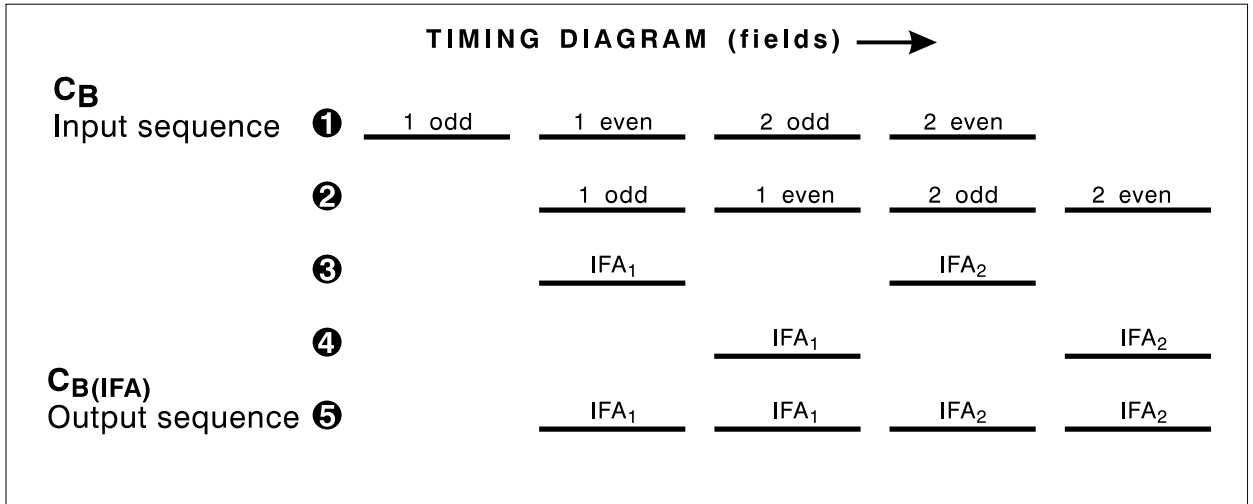
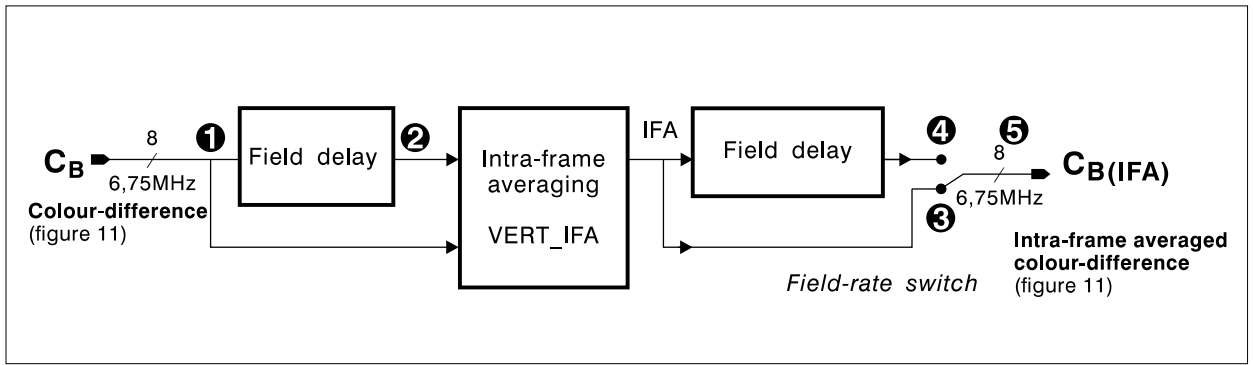

NOTE 1: Processing of C_R shall be identical of that of C_B.

NOTE 2: IFA_n = field of intra-frame averaged signal averaged from odd and even fields of frame n.

Figure 13: Motion Adaptive Colour Plus intra-frame averaging of chrominance

6.3.2 Motion detector operation

The motion detector provides control signals L and S to determine whether the spectrum above approximately 3 MHz carries both intra-frame averaged high-frequency luminance and intra-frame averaged chrominance, or non-intra-frame averaged chrominance. (The latter can be considered as sharing of this band between intra-frame averaged and intra-frame difference chrominance).

For the system to work correctly, it is important that the same motion signal is generated in both the encoder and the decoder. This means that the encoder shall not use information that is not available to the decoder. The motion detector therefore operates on intra-frame averaged chrominance. The Motion Adaptive Colour Plus encoding/decoding system has been designed such that intra-frame averaged chrominance is always recoverable in the decoder without cross effects, so that essentially identical signals are available in both the encoder and decoder.

The encoder motion detector is illustrated in figure 14. The incoming intra-frame averaged chrominance signals C_{B(IFA)} and C_{R(IFA)} shall be first low-pass filtered by filters ENC_MD_UV_LPF, to ensure that the motion detector operates on signals with comparable bandwidths in both the decoder and the encoder.

The signals then enter a PAL delay line. In the decoder (see annex C, subclause C.2.2.1), this prevents differential phase errors from affecting the motion detector, while in the encoder a delay line is required for symmetry with the decoder. The signals at the output of the delay line are C_{B(IFA)} and C_{R(IFA)}. A frame delay shall be then used to calculate C_{B(IFAD)} and C_{R(IFAD)}, the inter-frame difference of each of the intra-frame averaged chrominance signals.

ROM LUT_IFD_U_CLIP makes an absolute value from the inter-frame difference of intra-frame averaged signal in the C_B path and clips all numbers greater than 31. The output of this look-up table shall be therefore represented in 5 bits (0-31). Similarly, ROM LUT_IFD_V_CLIP makes an absolute value from the inter-frame difference of intra-frame averaged chrominance signal in the C_R path and clips all numbers greater than 15. The output shall be represented in 4 bits (0-15).

If the outputs of LUT_IFD_U_CLIP and LUT_IFD_V_CLIP are " $C_{R(IFAd)}$ " and " $C_{B(IFAd)}$ " respectively, then for LUT_IFD_U_CLIP:

$$C_{B(IFAd)} = |CB(IFAD)| \quad \text{for} \quad |CB(IFAD)| < 31$$

$$C_{B(IFAd)} = 31 \quad \text{for} \quad |CB(IFAD)| \geq 31$$

and for LUT_IFD_V_CLIP:

$$C_{R(IFAd)} = |CR(IFAD)| \quad \text{for} \quad |CR(IFAD)| < 15$$

$$C_{R(IFAd)} = 15 \quad \text{for} \quad |CR(IFAD)| \geq 15$$

The following ROM, LUT_MD_M, shall then generate motion signal M by the following method:

Firstly, calculate $C_{B'(IFAd)} = (11/16) * C_{B(IFAd)}$

then calculate M:

$$M = (5/16) * C_{B'(IFAd)} + C_{R(IFAd)} \quad \text{for} \quad C_{R(IFAd)} > C_{B'(IFAd)}$$

$$M = C_{B'(IFAd)} + (5/16) * C_{R(IFAd)} \quad \text{for} \quad C_{R(IFAd)} \leq C_{B'(IFAd)}$$

M shall be limited to a maximum value of 15, rounded and quantized to 4 bits.

M provides a representation of chrominance motion, based on differences in levels of chrominance between the previous and current frames. This motion signal shall be converted to a sample rate of 13,5 MHz by filter ENC_M_US prior to derivation of the luminance control signal.

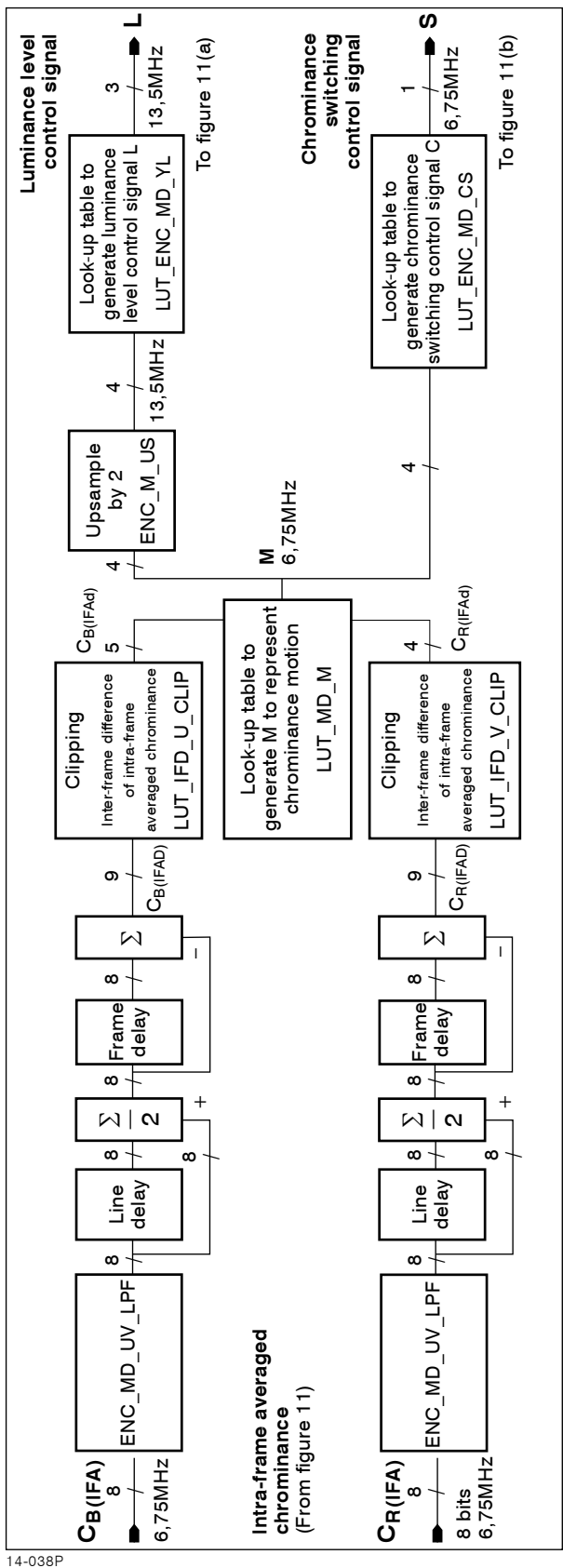

14-038P

Figure 14: Motion detector chain

Further ROMs LUT_ENC_MD_YL and LUT_ENC_MD_CS are used to scale and clip the motion signal M to produce the desired luminance control signal L and chrominance control signal S using the following functions:

$$L = 4*(11-M) \text{ where } L \text{ shall be clipped and scaled such that } 0 \leq L \leq 1$$

NOTE: The five possible values of the 3-bit level control signal represent the multiplication factors of 0, 1/4, 1/2, 3/4, and 1 respectively.

$$S = (M-13) \text{ where } S \text{ shall be clipped such that } 0 \leq S \leq 1$$

This results in a hard switch for S, and five possible levels for L, as illustrated in figure 15.

A control signal of value 0 means that the control signal will subsequently switch off the signal that is being controlled, while the maximum values of 1 for L and S imply the full amplitudes of the controlled signals.

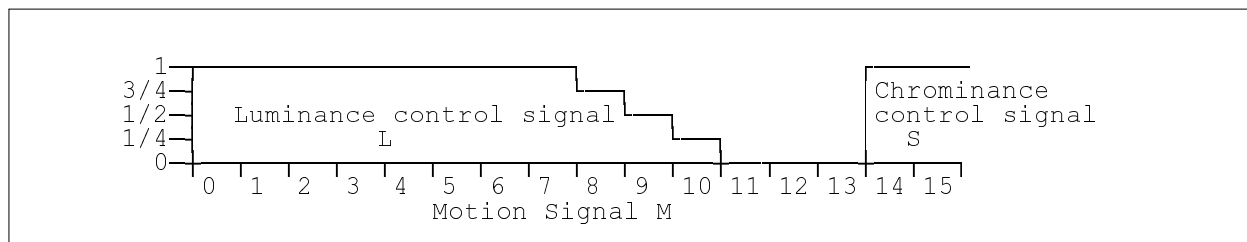

Figure 15: Derivation of luminance level control and chrominance switching signals in the encoder from the chrominance motion signal M

6.3.3 Non-PALplus use of Motion Adaptive Colour Plus

Motion Adaptive Colour Plus may be applied to any ITU-R Recommendation BT.601-5 [1] input source, regardless of the aspect ratio, without transmission of helper signals. This is referred to as "non-PALplus MACP".

In such cases, Motion Adaptive Colour Plus processing in both the encoder and the decoder shall take place on all 574 full active picture lines (lines 24-310 and 336-622), whatever the exact picture aspect ratio or setting of the Wide Screen Signalling aspect ratio bits (see subclause 6.6).

For such signals, the PALplus encoder shall either set both the second half of Line 23 and the first half of Line 623 to black level or, alternatively, shall include both the reference signals specified in subclause 6.5.

6.4 PAL encoding

The luminance and colour-difference signals shall be processed as described in subclauses 6.4.1 and 6.4.2, and as illustrated in figure 16.

Following summation of the signals in the luminance and chrominance paths, the output composite video signal comprises a 10-bit resolution (unsigned) signal at a rate of 13,5 MHz (quantizing scale = $0,00_{10}$ to $255,75_{10}$; black level = $64,00_{10}$, peak white = $192,00_{10}$, see figure 4 and subclause 5.2). The maximum peak-to-peak amplitudes of the modulated chrominance signals U and V are $112,00_{10}$ (U) and $157,50_{10}$ (V) respectively.

6.4.1 Luminance

Referring to figure 16, the incoming letterbox picture Y signal (in ITU-R Recommendation BT.601-5 [1] form) undergoes an appropriate delay to compensate for chrominance processing, following which scaling and shifting take place to convert from the 8-bit unsigned input in the range 16_{10} (black) to 235_{10} (peak white) to a 10-bit resolution unsigned output in the range $64,00_{10}$ (black) to $192,00_{10}$ (peak white).

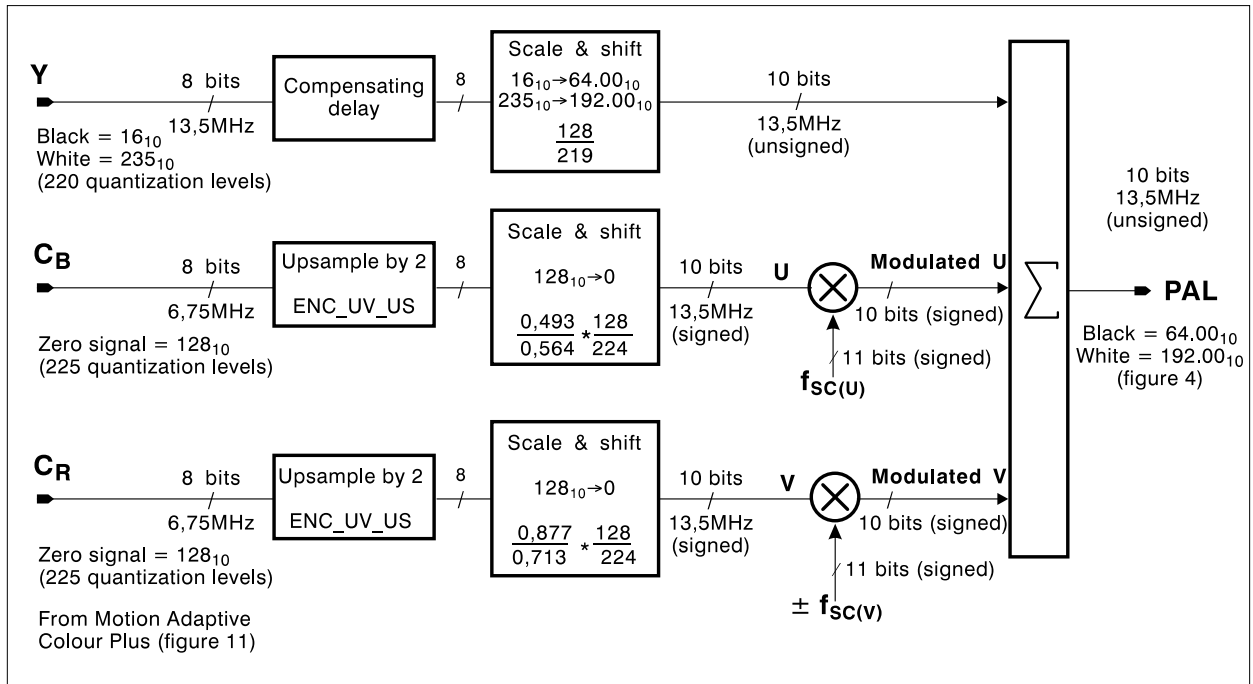

Figure 16: PAL encoding

6.4.2 Chrominance

Referring to figure 16, the letterbox picture C_B and C_R signals at the input (in ITU-R Recommendation BT.601-5 format: 8 bits unsigned at the rate of 6,75 MHz, and in the range 16_{10} to 240_{10}) are up-sampled by ENC_UV_US to 13,5 MHz, following which they undergo scaling and shifting to 10 bits, signed. They are then multiplied by signed signals representing the appropriate phases of PAL colour subcarrier.

6.5 Reference signals

When the transmission contains a modulated helper signal (i.e., when WSS bit $b_6=1$, see subclause 6.6) reference signals shall be inserted into the second half of Line 23 as defined in figure 17, and into the first half of Line 623 as defined in figure 18. (These active half-lines do not carry picture information after PALplus encoding). These reference signals may optionally be included in transmissions of non-PALplus MACP (see subclause 6.3.3).

The rise-and-fall times (and tolerances) of the helper reference burst in the second half of Line 23 shall be the same as those of the PAL colour burst.

The helper reference burst in Line 23 shall be colour subcarrier with phase of minus U, corresponding to the peak amplitude of the modulated helper signal.

It is recommended that the required reference signals in Line 23 (see figure 17) be generated by applying a square wave baseband signal at the input to the helper encoder (see figure 9). This maximises commonality of processing between the helper references and helper signals, and allows for the compensation of any non-ideal characteristics in the helper encoder. (At baseband, black-level is represented by 128_{10} and the helper reference burst by $128_{10} - 109_{10}$). The rise-and-fall times shall be the same as those of line blanking given in ITU-R Recommendation BT.470-4 [2].

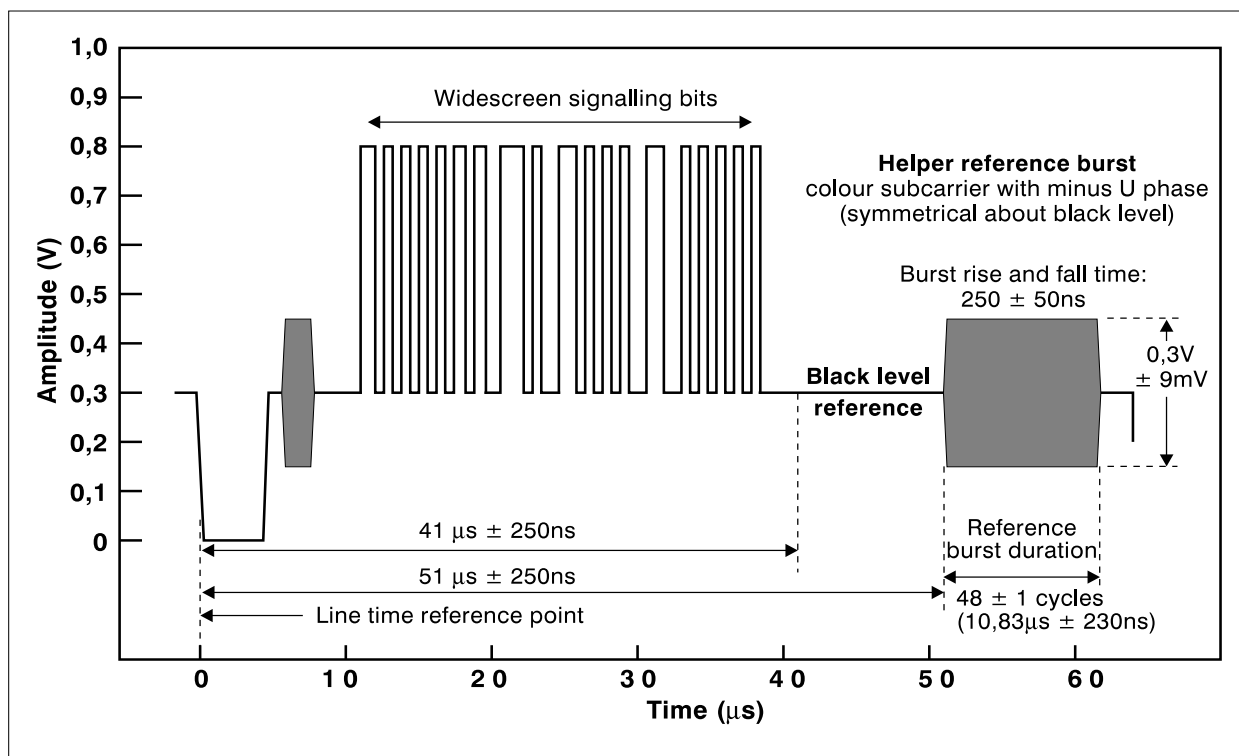

NOTE 1: It is recommended that the reference signals be generated by applying appropriate baseband signals to the helper encoder.

NOTE 2: The phase of the helper reference burst will differ from minus U during its rise and fall periods.

Figure 17: Reference signals in Line 23

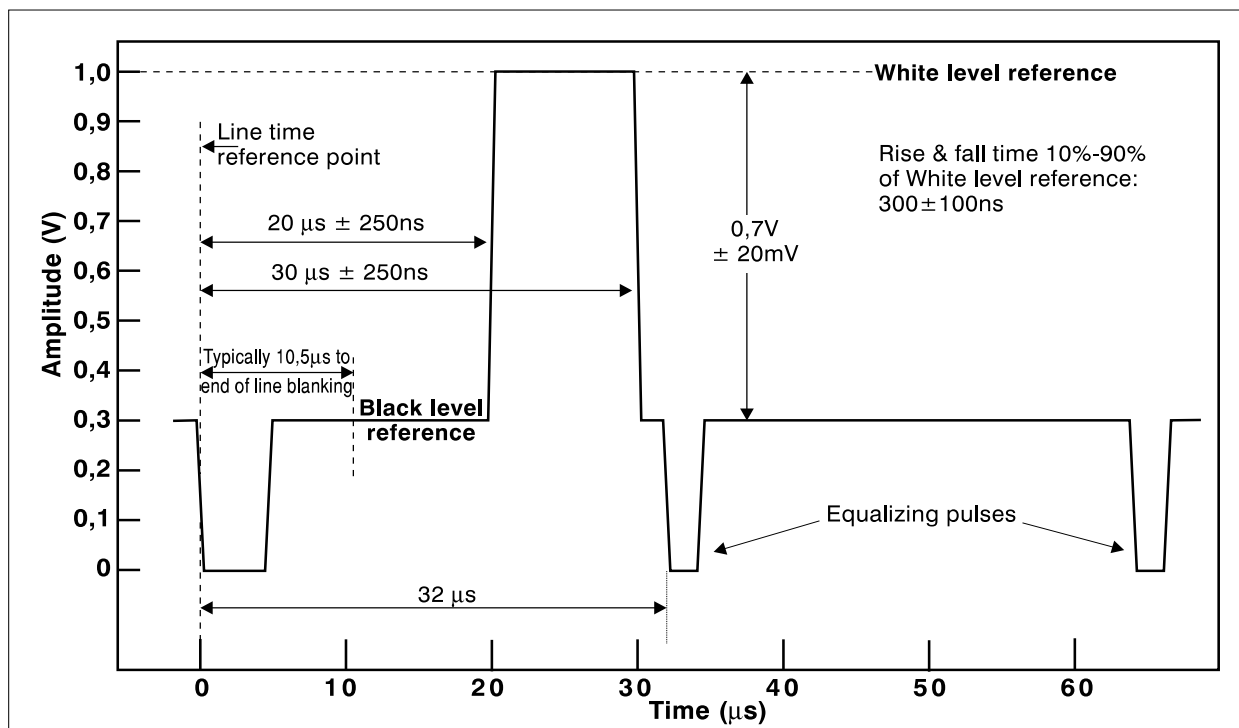

NOTE: There is no colour burst in Line 623.

Figure 18: Reference signals in Line 623

Table 2 summarises the contents of the second half of Line 23 and first half of Line 623:

Table 2: Summary of contents of second half of Line 23 and first half of Line 623

b_6b_5	Contents second half Line 23, first half Line 623
1x	reference signals (see figures 17 and 18)
01	black or reference signals (see figures 17 and 18)
00	active picture

6.5.1 Helper reference signals with baseband helper

Consumer PALplus decoders have no requirement to process variants of PALplus in which the helper is unmodulated and remains in baseband form, and there is no provision in the signalling system see ETS 300 294 [4] to indicate the transmission of such a signal. However, such variants could be contemplated for studio/distribution or other internal non-broadcast applications.

If taken from the output of the encoder vertical conversion process, a baseband helper would be centred on a DC pedestal of 350 mV ($128,00_{10}$). If use is to be made of this signal format, it is particularly important to maintain an accurate DC-level reference during processing in order to ensure correct reconstruction. Attention is drawn to the potential difficulties in achieving this with signals in analogue form, although such problems need not exist if signal processing is confined solely to the digital domain prior to subsequent decoding or transcoding to a normal PALplus signal.

In the case of a baseband helper in analogue form, referring to figure 17, the black-level of the helper DC-level reference and the DC-level of the helper reference burst might both be replaced by a mid-grey set-up of 350 mV ($128,00_{10}$). The modulated minus U reference burst could be replaced by a negative-going DC offset, relative to the set-up, to indicate the amplitude range of the baseband helper.

6.6 Signalling

The correct operation of PALplus requires certain status bits to be conveyed to the decoder. The Wide Screen Signalling (WSS) system shall be used, as specified in ETS 300 294 [4]. This makes use of data inserted into the first half of Line 23 by the PALplus encoder.

The information required specifically for PALplus is to indicate the use of Motion Adaptive Colour Plus encoding, and to indicate the presence of the modulated vertical helper signal.

This information shall be conveyed by two bits within Group 2 ("Enhanced Services") of the WSS:

Table 3: Use of bit b_5 to indicate Motion Adaptive Colour Plus encoding

b_5	Colour coding process
0	Standard PAL
1	Motion Adaptive Colour Plus
NOTE:	In film mode ($b_4=1$) Motion Adaptive Colour Plus shall be set to "fixed" Colour Plus operation, i.e., is not motion adaptive.

Table 4: Use of bit b_6 to signal the presence of the modulated helper signal

b_6	Helper signal
0	no helper
1	modulated helper
NOTE 1:	A helper signal shall be present only when the aspect ratio is "16:9 letterbox centre" or ">16:9 letterbox centre", and only with ≤ 430 active picture lines.
NOTE 2:	A helper signal shall not be present for transmissions signalled as having "subtitles out of active image area" ($b_9=0$, $b_{10}=1$).

In addition, a PALplus transmission shall carry appropriate information in film bit b_4 to signal the presence of camera mode or film mode:

Table 5: Use of Film bit b_4

b_4	Film bit
0	camera mode
1	film mode

A PALplus transmission shall make use of the aspect ratio label bits (b_0, b_1, b_2, b_3) carried in WSS Group 1, in order to signal a central 16:9 letterbox.

For PALplus, the following WSS signalling bits shall be set as follows:

$b_2=1, b_1=1, b_2=0, b_3=1, b_4=\text{camera/film bit}, b_5=1, b_6=1$

For non-PALplus MACP, the following WSS signalling bits shall be set as follows:

$b_2=x, b_1=x, b_2=x, b_3=\text{odd parity bit}, b_4=\text{camera/film}, b_5=1, b_6=0$

Some further examples of the use of Wide Screen Signalling and receiver-related issues are given in annex F, clause F.5.

Annex A (normative): Filter and look-up table coefficients

A.1 General rules for filter descriptions

Most filters are odd-symmetrical, in which case the centre tap coefficient is given as <n>, together with one tail of coefficients.

In addition, where appropriate, the filtering operation is defined by reference to additional mathematical descriptions and diagrams.

A.1.1 General rules for horizontal filters

- each coefficient shall be in the range -256 to +255;
- the divider should be a power of 2.

A.1.2 General rules for vertical filters

- each coefficient shall be in the range -128 to +127;
- the divider should be a power of 2 and a maximum of 128.

Where mathematical descriptions are given, for each filter, the input signal is referred to as Y_{in} and the output signal as Y_{out} , irrespective of the nature of the signal (i.e., whether representing luminance, luminance vertical helper, or chrominance).

If an input signal is not contained within the active picture area, or the picture area defined to be valid for a particular filter, the value of the input signal shall be set to black (value 16_{10} in the case of luminance, 128_{10} for colour-difference signals and helper signals).

A.2 Vertical conversion

A.2.1 ENC_Y_QMF (camera mode)

(Luminance 576 -> 430 line conversion - camera mode, see figure 5)

$$0 \leq n \leq 71$$

$$\text{if } n \leq 35 \text{ then } ad(n)=0 \text{ else } ad(n)=215$$

NOTE 1: Do not calculate lines 59 and 587 !

NOTE 2: In practice, output helper lines have a mid-grey set-up of 128_{10} .

NOTE 3: The QMF filtering process shall be applied as shown in figures A.1, A.2 and A.3.

Phase 1:

$$Y_{out}(59+n*3) = 1/128 * (\begin{array}{l} 3 * Y_{in}(23+n*4-3) \\ -8 * Y_{in}(23+n*4-2) \\ + 15 * Y_{in}(23+n*4-1) \\ + 108 * Y_{in}(23+n*4) \\ + 15 * Y_{in}(23+n*4+1) \\ - 8 * Y_{in}(23+n*4+2) \\ + 3 * Y_{in}(23+n*4+3) \end{array})$$

Phase 2:

$$\begin{aligned} Y_{out}(59+n*3+1) = 1/128 * (& 1 * Y_{in}(23+n*4-2) \\ & + 0 * Y_{in}(23+n*4-1) \\ & - 10 * Y_{in}(23+n*4) \\ & + 93 * Y_{in}(23+n*4+1) \\ & + 56 * Y_{in}(23+n*4+2) \\ & - 15 * Y_{in}(23+n*4+3) \\ & + 3 * Y_{in}(23+n*4+4)) \end{aligned}$$

Phase 3:

$$\begin{aligned} Y_{out}(59+n*3+2) = 1/128 * (& 3 * Y_{in}(23+n*4) \\ & - 15 * Y_{in}(23+n*4+1) \\ & + 56 * Y_{in}(23+n*4+2) \\ & + 93 * Y_{in}(23+n*4+3) \\ & - 10 * Y_{in}(23+n*4+4) \\ & + 0 * Y_{in}(23+n*4+5) \\ & + 1 * Y_{in}(23+n*4+6)) \end{aligned}$$

Phase 4 (Helper):

$$\begin{aligned} Y_{out}(24+n+ad(n)) = 1/128 * (& 9 * Y_{in}(23+n*4) \\ & - 31 * Y_{in}(23+n*4+1) \\ & + 44 * Y_{in}(23+n*4+2) \\ & - 31 * Y_{in}(23+n*4+3) \\ & + 9 * Y_{in}(23+n*4+4)) \end{aligned}$$

Phase 5:

$$\begin{aligned} Y_{out}(372+n*3) = 1/128 * (& 2 * Y_{in}(336+n*4-3) \\ & - 4 * Y_{in}(336+n*4-2) \\ & + 1 * Y_{in}(336+n*4-1) \\ & + 104 * Y_{in}(336+n*4) \\ & + 35 * Y_{in}(336+n*4+1) \\ & - 13 * Y_{in}(336+n*4+2) \\ & + 3 * Y_{in}(336+n*4+3)) \end{aligned}$$

Phase 6:

$$\begin{aligned}
 Y_{out}(372+n*3+1) = 1/128 * (& 2 * Y_{in}(336+n*4-1) \\
 & - 14 * Y_{in}(336+n*4) \\
 & + 76 * Y_{in}(336+n*4+1) \\
 & + 76 * Y_{in}(336+n*4+2) \\
 & - 14 * Y_{in}(336+n*4+3) \\
 & + 2 * Y_{in}(336+n*4+4))
 \end{aligned}$$

Phase 7:

$$\begin{aligned}
 Y_{out}(372+n*3+2) = 1/128 * (& 3 * Y_{in}(336+n*4) \\
 & - 13 * Y_{in}(336+n*4+1) \\
 & + 35 * Y_{in}(336+n*4+2) \\
 & + 104 * Y_{in}(336+n*4+3) \\
 & + 1 * Y_{in}(336+n*4+4) \\
 & - 4 * Y_{in}(336+n*4+5) \\
 & + 2 * Y_{in}(336+n*4+6))
 \end{aligned}$$

Phase 8 (Helper):

$$\begin{aligned}
 Y_{out}(336+n+ad(n)) = 1/128 * (& 2 * Y_{in}(336+n*4-1) \\
 & - 19 * Y_{in}(336+n*4) \\
 & + 41 * Y_{in}(336+n*4+1) \\
 & - 41 * Y_{in}(336+n*4+2) \\
 & + 19 * Y_{in}(336+n*4+3) \\
 & - 2 * Y_{in}(336+n*4+4))
 \end{aligned}$$

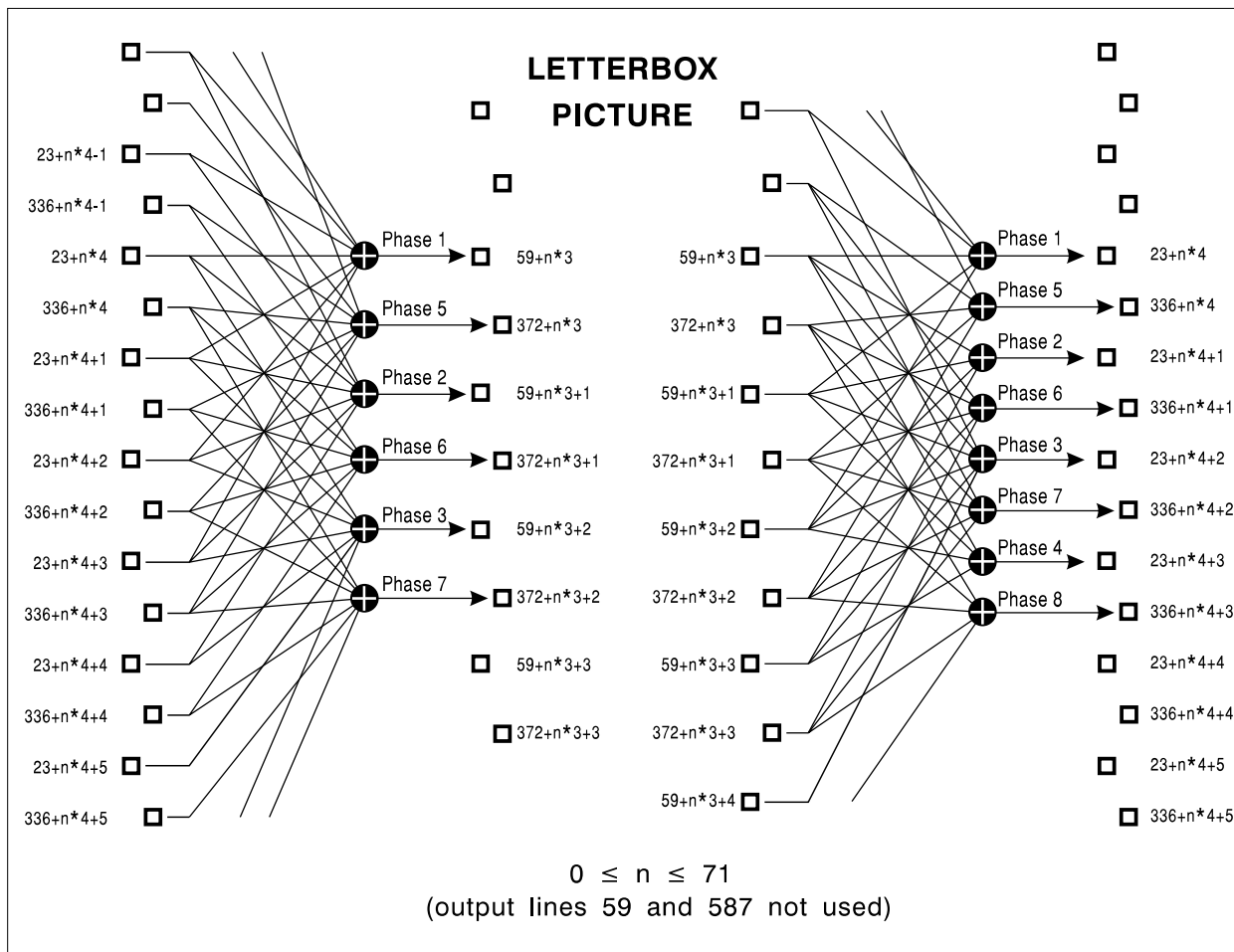

NOTE: Figures A.1, A.2 and A.3 illustrate the operation of the entire format conversion process for luminance in both the encoder and decoder (576 → 430 → 576 lines, field based).

Figure A.1: Application of the QMF filtering process (camera mode, letterbox part)

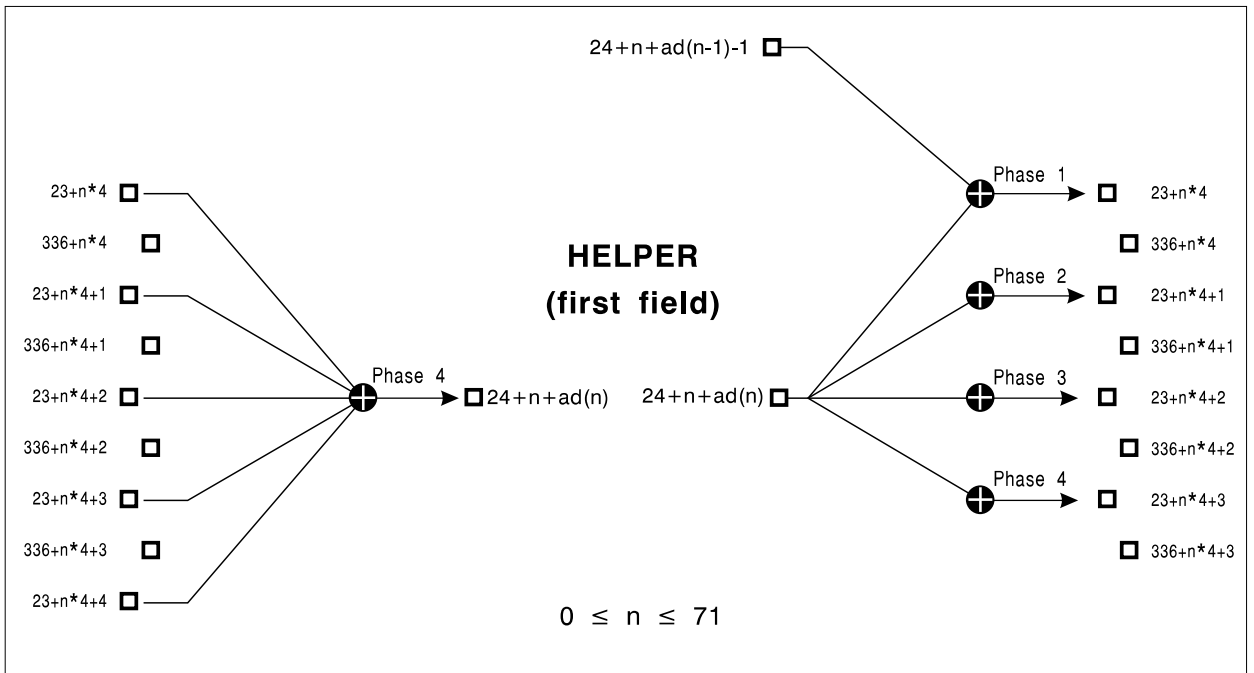

Figure A.2: Application of the QMF filtering process (camera mode, first field, helper part)

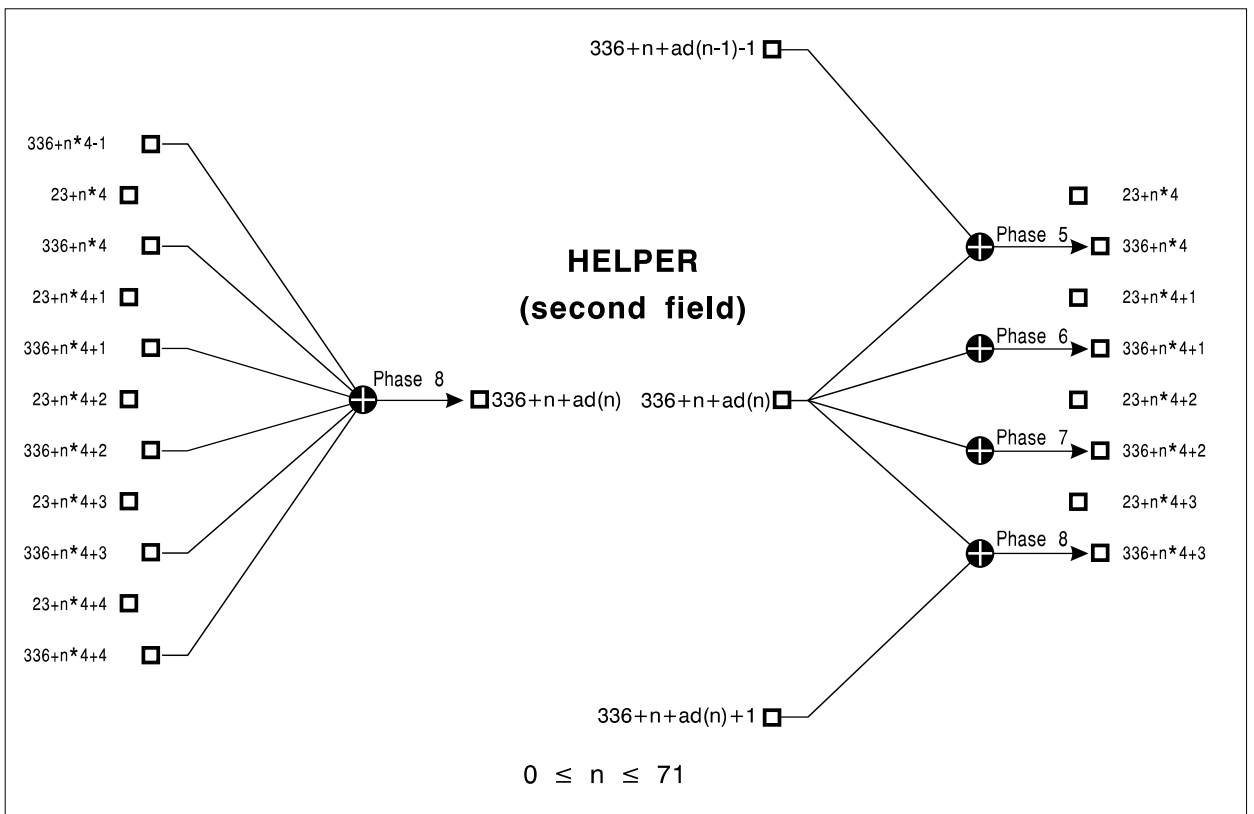

Figure A.3: Application of the QMF filtering process (camera mode, second field, helper part)

A.2.2 ENC_Y_QMF (film mode)

(Luminance 576 -> 430 line conversion - film mode, see figure 6)

$$0 \leq n \leq 71$$

if $n \leq 35$ then $ad(n)=0$

else $ad(n)=215$

NOTE 1: Do not calculate lines 59 and 587!

NOTE 2: In practice, output helper lines have a mid-grey set-up of 128_{10} .

NOTE 3: The QMF filtering process is applied as shown in figures A.4 and A.5.

Phase 1:

$$Y_{out}(59+n*3) = 1/128 * (\begin{aligned} & 3 * Y_{in}(336+n*4-2) \\ & - 8 * Y_{in}(23+n*4-1) \\ & + 15 * Y_{in}(336+n*4-1) \\ & + 108 * Y_{in}(23+n*4) \\ & + 15 * Y_{in}(336+n*4) \\ & - 8 * Y_{in}(23+n*4+1) \\ & + 3 * Y_{in}(336+n*4+1) \end{aligned})$$

Phase 2:

$$Y_{out}(372+n*3) = 1/128 * (\begin{aligned} & 1 * Y_{in}(23+n*4-1) \\ & + 0 * Y_{in}(336+n*4-1) \\ & - 10 * Y_{in}(23+n*4) \\ & + 93 * Y_{in}(336+n*4) \\ & + 56 * Y_{in}(23+n*4+1) \\ & - 15 * Y_{in}(336+n*4+1) \\ & + 3 * Y_{in}(23+n*4+2) \end{aligned})$$

Phase 3:

$$Y_{out}(59+n*3+1) = 1/128 * (\begin{aligned} & 3 * Y_{in}(23+n*4) \\ & - 15 * Y_{in}(336+n*4) \\ & + 56 * Y_{in}(23+n*4+1) \\ & + 93 * Y_{in}(336+n*4+1) \\ & - 10 * Y_{in}(23+n*4+2) \\ & + 0 * Y_{in}(336+n*4+2) \\ & + 1 * Y_{in}(23+n*4+3) \end{aligned})$$

Phase 4 (Helper):

$$\begin{aligned}
 Y_{\text{out}}(24+n+\text{ad}(n)) = & 1/128 * (\\
 & 9 * Y_{\text{in}}(23+n*4) \\
 & - 31 * Y_{\text{in}}(336+n*4) \\
 & + 44 * Y_{\text{in}}(23+n*4+1) \\
 & - 31 * Y_{\text{in}}(336+n*4+1) \\
 & + 9 * Y_{\text{in}}(23+n*4+2) \quad)
 \end{aligned}$$

Phase 5:

$$\begin{aligned}
 Y_{\text{out}}(372+n*3+1) = & 1/128 * (\\
 & 3 * Y_{\text{in}}(336+n*4) \\
 & - 8 * Y_{\text{in}}(23+n*4+1) \\
 & + 15 * Y_{\text{in}}(336+n*4+1) \\
 & + 108 * Y_{\text{in}}(23+n*4+2) \\
 & + 15 * Y_{\text{in}}(336+n*4+2) \\
 & - 8 * Y_{\text{in}}(23+n*4+3) \\
 & + 3 * Y_{\text{in}}(336+n*4+3) \quad)
 \end{aligned}$$

Phase 6:

$$\begin{aligned}
 Y_{\text{out}}(59+n*3+2) = & 1/128 * (\\
 & 1 * Y_{\text{in}}(23+n*4+1) \\
 & + 0 * Y_{\text{in}}(336+n*4+1) \\
 & - 10 * Y_{\text{in}}(23+n*4+2) \\
 & + 93 * Y_{\text{in}}(336+n*4+2) \\
 & + 56 * Y_{\text{in}}(23+n*4+3) \\
 & - 15 * Y_{\text{in}}(336+n*4+3) \\
 & + 3 * Y_{\text{in}}(23+n*4+4) \quad)
 \end{aligned}$$

Phase 7:

$$\begin{aligned}
 Y_{\text{out}}(372+n*3+2) = & 1/128 * (\\
 & 3 * Y_{\text{in}}(23+n*4+2) \\
 & - 15 * Y_{\text{in}}(336+n*4+2) \\
 & + 56 * Y_{\text{in}}(23+n*4+3) \\
 & + 93 * Y_{\text{in}}(336+n*4+3) \\
 & - 10 * Y_{\text{in}}(23+n*4+4) \\
 & + 0 * Y_{\text{in}}(336+n*4+4) \\
 & + 1 * Y_{\text{in}}(23+n*4+5) \quad)
 \end{aligned}$$

Phase 8 (Helper):

$$Y_{out}(336+n+ad(n)) = 1/128 * (9 * Y_{in}(23+n*4+2) - 31 * Y_{in}(336+n*4+2) + 44 * Y_{in}(23+n*4+3) - 31 * Y_{in}(336+n*4+3) + 9 * Y_{in}(23+n*4+4))$$

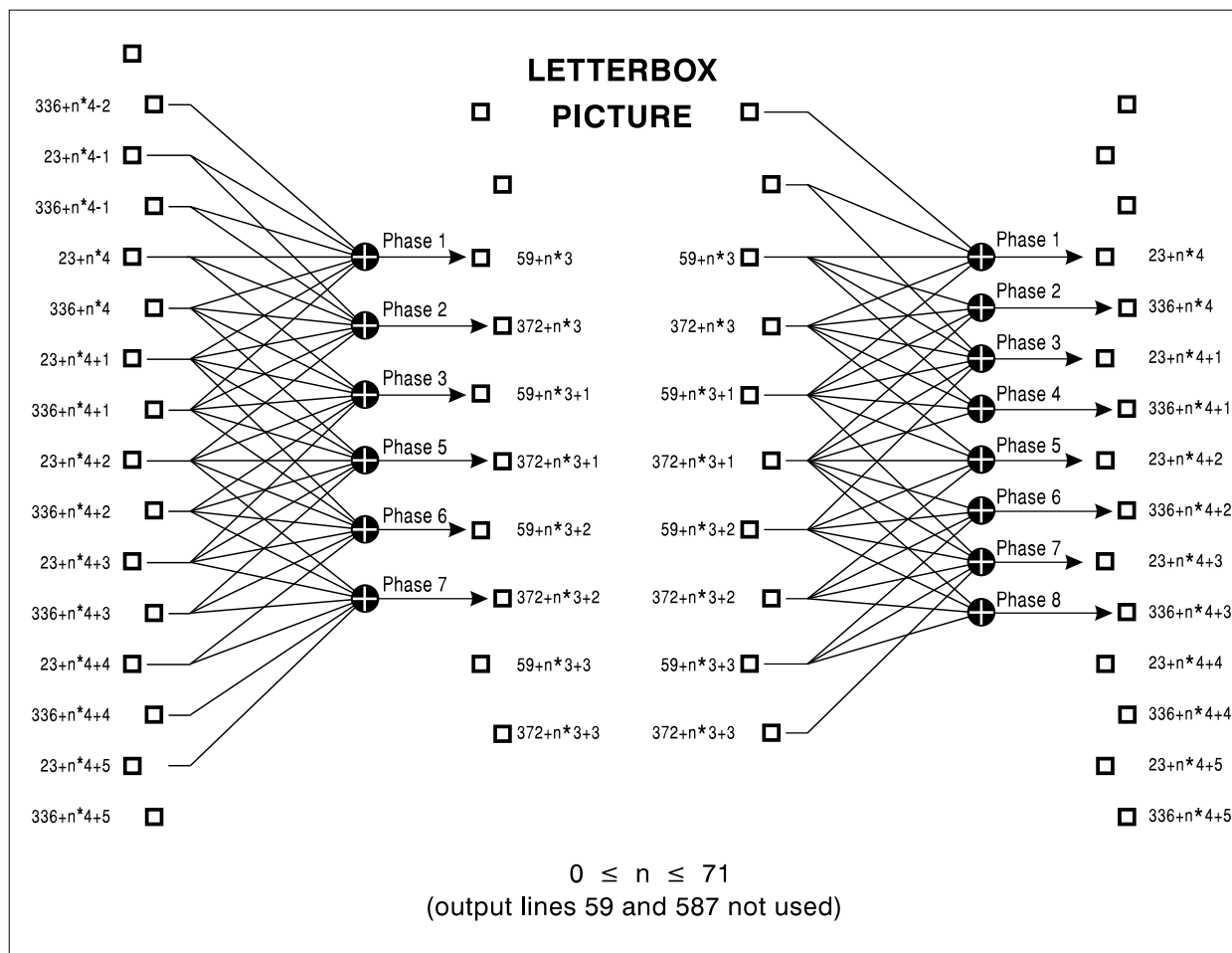

NOTE: Figures A.4 and A.5 illustrate the operation of the entire conversion process for luminance in both the encoder and decoder 576 → 430 → 576 lines, frame based).

Figure A.4: Application of the QMF filtering process (film mode, letterbox part)

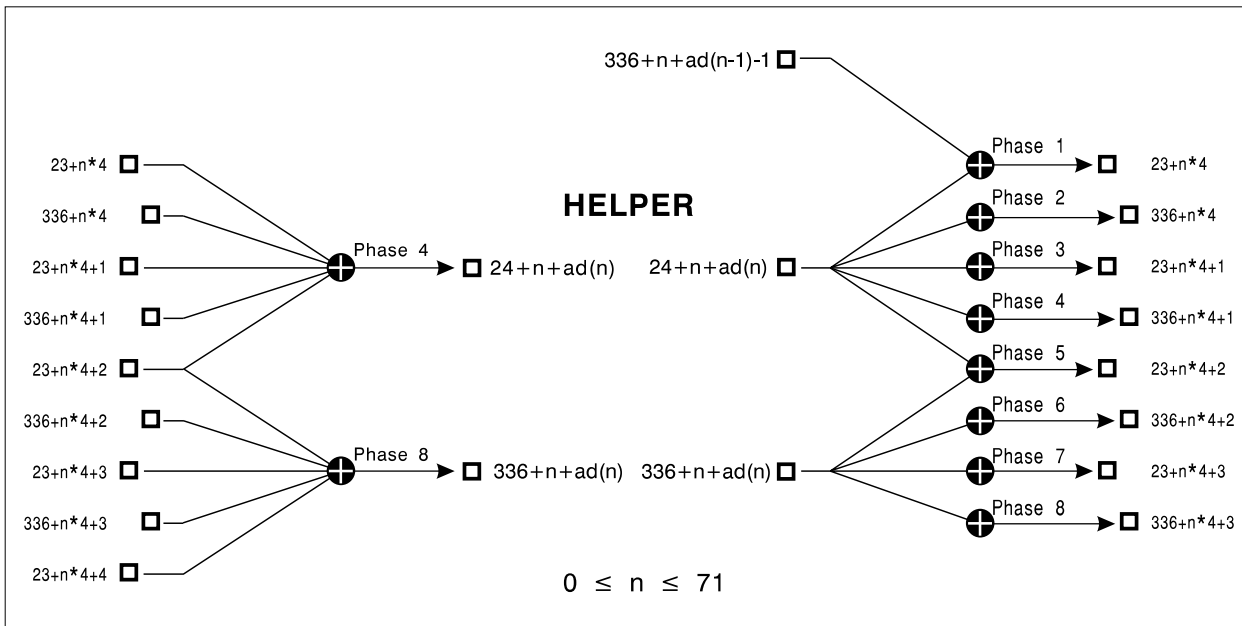

Figure A.5: Application of the QMF filtering process (film mode, helper part)

A.2.3 ENC_UV_C_VSRC

(Encoder colour-difference signal vertical sample rate conversion, (camera mode), see figure 5)

Sampling grid in: field based, 288 lines

Sampling grid out: field based, 216 lines

23 taps, total sum = 768 (sum per phase = 128)

<80> 79 74 63 51 40 24 15 6 1 -3 -6

The filter shall be applied as shown in figure A.6 and as follows:

$$0 \leq n \leq 71$$

NOTE: Do not calculate lines 59 and 587.

Phase 1:

$$Y_{out}(59+n*3) = 1/128 * (24 * Y_{in}(23+n*4-1) + 80 * Y_{in}(23+n*4) + 24 * Y_{in}(23+n*4+1))$$

Phase 2:

$$Y_{out}(59+n*3+1) = 1/128 * (6 * Y_{in}(23+n*4) + 74 * Y_{in}(23+n*4+1) + 51 * Y_{in}(23+n*4+2) - 3 * Y_{in}(23+n*4+3))$$

Phase 3:

$$\begin{aligned} Y_{out}(59+n*3+2) = 1/128 * (& -3 * Y_{in}(23+n*4+1) \\ & + 51 * Y_{in}(23+n*4+2) \\ & + 74 * Y_{in}(23+n*4+3) \\ & + 6 * Y_{in}(23+n*4+4)) \end{aligned}$$

Phase 4:

$$\begin{aligned} Y_{out}(372+n*3) = 1/128 * (& 15 * Y_{in}(336+n*4-1) \\ & + 79 * Y_{in}(336+n*4) \\ & + 40 * Y_{in}(336+n*4+1) \\ & - 6 * Y_{in}(336+n*4+2)) \end{aligned}$$

Phase 5:

$$\begin{aligned} Y_{out}(372+n*3+1) = 1/128 * (& 1 * Y_{in}(336+n*4) \\ & + 63 * Y_{in}(336+n*4+1) \\ & + 63 * Y_{in}(336+n*4+2) \\ & + 1 * Y_{in}(336+n*4+3)) \end{aligned}$$

Phase 6:

$$\begin{aligned} Y_{out}(372+n*3+2) = 1/128 * (& -6 * Y_{in}(336+n*4+1) \\ & + 40 * Y_{in}(336+n*4+2) \\ & + 79 * Y_{in}(336+n*4+3) \\ & + 15 * Y_{in}(336+n*4+4)) \end{aligned}$$

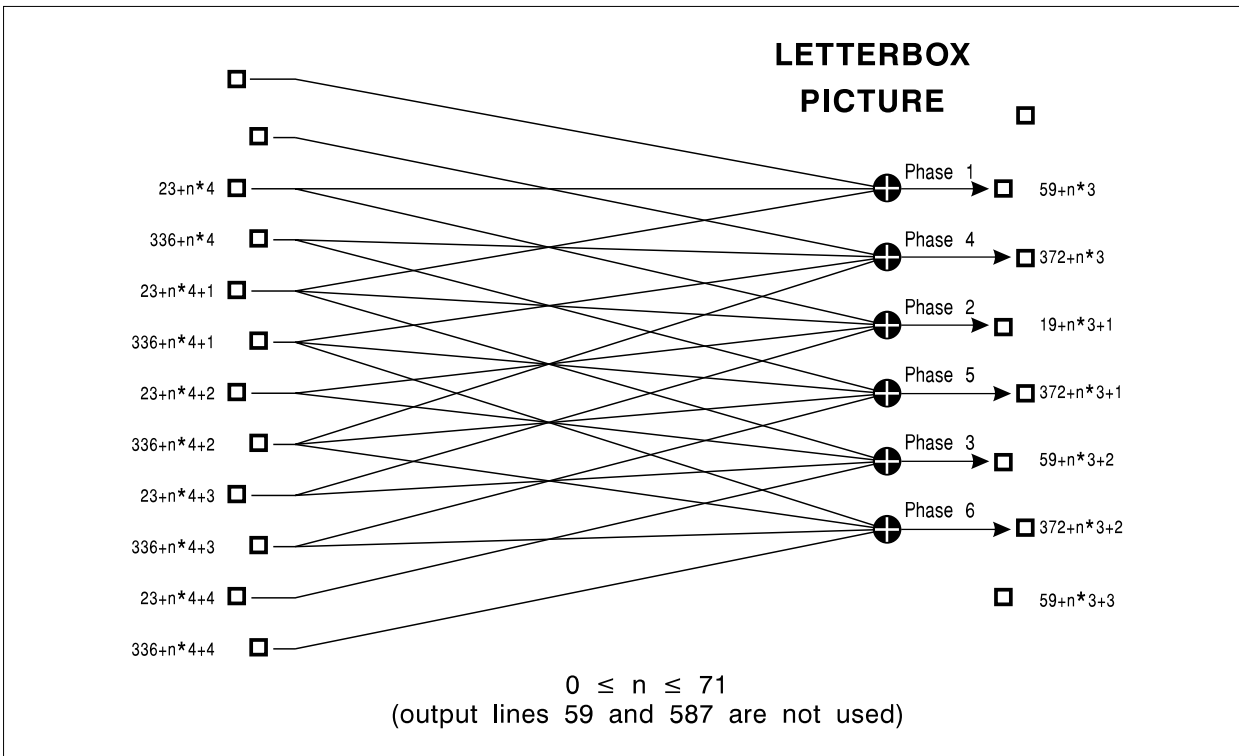

NOTE: This drawing illustrates the operation of the entire camera mode vertical conversion process for chrominance signals shown in figure 5 (288 → 216 lines).

Figure A.6: ENC_UV_C_VSRC

A.2.4 ENC_UV_F_VSRC

(Encoder colour-difference signal vertical sample rate conversion (film mode), see figure 6)

Sampling grid in: frame based, 576 lines

Sampling grid out: field based, 216 lines

15 taps, total sum = 768 (sum per phase = 256)

<96> 94 83 64 47 28 16 4

The filter shall be applied as shown in figure A.7 and as follows:

$0 \leq n \leq 71$

NOTE 1: Do not calculate lines 275 and 587.

NOTE 2: The initial phase of ENC_UV_F_VSRC differs to that of the other vertical filters.

Phase 1:

$$\begin{aligned} Y_{out}(59+n*3+1) = 1/256 * (& 16 * Y_{in}(23+n*4) \\ & + 64 * Y_{in}(336+n*4) \\ & + 96 * Y_{in}(23+n*4+1) \\ & + 64 * Y_{in}(336+n*4+1) \\ & + 16 * Y_{in}(23+n*4+2)) \end{aligned}$$

$$Y_{out}(372+n*3) = Y_{out}(59+n*3+1)$$

Phase 2:

$$\begin{aligned} Y_{out}(59+n*3+2) = 1/256 * (& 28 * Y_{in}(336+n*4+1) \\ & + 83 * Y_{in}(23+n*4+2) \\ & + 94 * Y_{in}(336+n*4+2) \\ & + 47 * Y_{in}(23+n*4+3) \\ & + 4 * Y_{in}(336+n*4+3)) \end{aligned}$$

$$Y_{out}(372+n*3+1) = Y_{out}(59+n*3+2)$$

Phase 3:

$$\begin{aligned} Y_{out}(59+n*3+3) = 1/256 * (& 4 * Y_{in}(336+n*4+2) \\ & + 47 * Y_{in}(23+n*4+3) \\ & + 94 * Y_{in}(336+n*4+3) \\ & + 83 * Y_{in}(23+n*4+4) \\ & + 28 * Y_{in}(336+n*4+4)) \end{aligned}$$

$$Y_{out}(372+n*3+2) = Y_{out}(59+n*3+3)$$

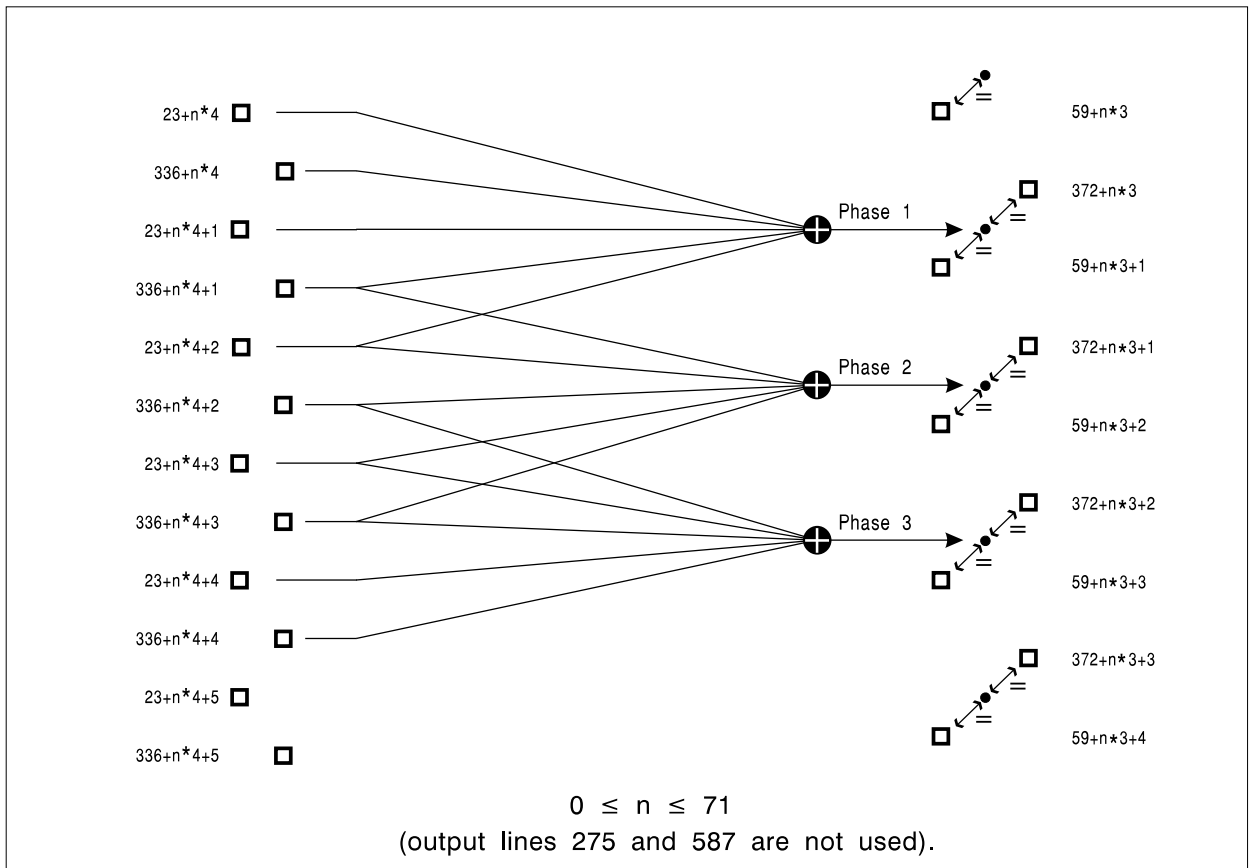

NOTE: This drawing illustrates the operation of the entire film mode vertical conversion process for chrominance signals shown in figure 6 (576 → 216 lines).

Figure A.7: ENC_UV_F_VSRC

A.3 Helper encoding

A.3.1 ENC_BB_US

(Encoder black-band up-sample low-pass filter, see figure 9)

(up-sample by 2: in = 13,5 MHz; out = 27 MHz)

31 taps, total sum = 512 (sum per phase = 256)

<152> 129 77 18 -20 -28 -15 4 13 10 1 -5 -5 -2 1 2

A.3.2 ENC_BB_PRE_MOD_LPF_SS

(Encoder black-band pre-modulation low-pass and spectrum shaping filter, see figure 9)

(in = out = 27 MHz)

29 taps, sum = 512

<86> 79 61 38 15 -2 -9 -8 -2 5 10 11 9 5 1

A.3.3 ENC_BB_POST_MOD_NYQ

(Encoder black-band post-modulation low-pass filter including full-Nyquist slope)

(Downsample by 2: in = 27 MHz, out = 13,5 MHz)

29 taps, sum = 512

<170> 140 71 2 -31 -27 -3 15 14 1 -9 -9 -2 4 5

A.3.4 LUT_BB_ENC (film mode)

(Helper encoder ROM look-up table, companding, see figure 9)

input value x	+0	+1	+2	+3	+4	+5	+6	+7
0	19	19	19	19	19	19	19	19
8	19	19	19	19	19	19	19	19
6	19	19	19	19	19	19	19	19
24	19	19	19	19	19	19	19	19
32	19	19	19	19	19	19	19	19
40	19	19	19	19	19	19	19	19
48	19	19	19	19	19	19	19	19
56	19	19	19	19	19	19	19	19
64	19	19	19	19	19	19	19	19
72	19	19	19	19	19	19	19	19
80	19	19	19	19	19	19	19	19
88	19	19	19	19	19	19	19	19
96	19	19	19	19	19	19	19	19
104	19	19	20	23	26	30	33	37
112	41	45	49	53	58	63	68	73
120	79	85	92	99	128	128	128	128
128	128	128	128	128	128	157	164	171
136	177	183	188	193	198	203	207	211
144	215	219	223	226	230	233	236	237
152	237	237	237	237	237	237	237	237
160	237	237	237	237	237	237	237	237
168	237	237	237	237	237	237	237	237
176	237	237	237	237	237	237	237	237
184	237	237	237	237	237	237	237	237
192	237	237	237	237	237	237	237	237
200	237	237	237	237	237	237	237	237
208	237	237	237	237	237	237	237	237
216	237	237	237	237	237	237	237	237
224	237	237	237	237	237	237	237	237
232	237	237	237	237	237	237	237	237
240	237	237	237	237	237	237	237	237
248	237	237	237	237	237	237	237	237

See annex A, subclause A.3.5 for derivation of the above values.

A.3.5 LUT_BB_ENC (camera mode)

(Helper encoder ROM look-up table, companding, see figure 9)

input value x	+0	+1	+2	+3	+4	+5	+6	+7
0	19	19	19	19	19	19	19	19
8	19	19	19	19	19	19	19	19
6	19	19	19	19	19	19	19	19
24	19	19	19	19	19	19	19	19
32	19	19	19	19	19	19	19	19
40	19	19	20	20	21	21	22	22
48	23	23	24	24	25	26	26	27
56	27	28	28	29	30	30	31	32
64	32	33	34	34	35	36	36	37
72	38	39	39	40	41	42	43	43
80	44	45	46	47	48	49	50	51
88	52	53	54	55	56	57	58	59
96	60	61	63	64	65	67	68	69
104	71	72	74	75	77	79	81	82
112	84	86	88	91	93	95	98	101
120	104	107	110	113	128	128	128	128
128	128	128	128	128	128	143	146	149
136	152	155	158	161	163	165	168	170
144	172	174	175	177	179	181	182	184
152	185	187	188	189	191	192	193	195
160	196	197	198	199	200	201	202	203
168	204	205	206	207	208	209	210	211
176	212	213	213	214	215	216	217	217
184	218	219	220	220	221	222	222	223
192	224	224	225	226	226	227	228	228
200	229	229	230	230	231	232	232	233
208	233	234	234	235	235	236	236	237
216	237	237	237	237	237	237	237	237
224	237	237	237	237	237	237	237	237
232	237	237	237	237	237	237	237	237
240	237	237	237	237	237	237	237	237
248	237	237	237	237	237	237	237	237

The above values are derived from the following scaleable formula:

IF $x \leq 0,04 * X_{range}$ *THEN* $y' = 0$

$$\text{IF } x > 0,04 * X_{range} \text{ THEN } y' = Y_{range} * \frac{\left[\frac{x}{X_{range}} + p3 \right]^{p1}}{p4 + p3} - p2$$

$$y = \text{MIN} [y' * \text{AmplFactor}, Y_{range}]$$

where:

- x is the absolute non-companded value and y is the absolute companded value;
- $p1 = 0,0010$; $p2 = 0,9977126$; $p3 = 0,07477$; $p4 = 0,79981$;
- AmplFactor = 1 (camera mode), AmplFactor = 2 (film mode);

- the ranges are indicated with X_{range} and Y_{range} (both are 109).

NOTE 1: The DC-shift (128_{10}) is not included in the formula.

NOTE 2: The companding curve is symmetrical about zero, such that negative values for x and y are derived directly from the absolute values provided by the formula.

A.4 Motion Adaptive Colour Plus

A.4.1 Y_BSPLIT

(Luminance band-splitting filter, see figure 11)

(in = out = 13,5 MHz)

17 taps, sum = 256

<114> 79 13 -21 -10 7 7 -2 -2

A.4.2 ENC_Y_IFA

(Luminance intra-frame averaging vertical filter, see figure 12)

Sampling grid in: frame based

430 lines (PALplus) or 574 lines (non-PALplus MACP)

Sampling grid out: field based

215 lines (PALplus) or 287 lines (non-PALplus MACP)

10 taps, sum = 128

3 -6 -10 18 59 59 18 -10 -6 3

NOTE: This filter is even-symmetrical.

The filter shall be applied as shown in figure A.8 and as follows:

$0 \leq n \leq 214$ (PALplus 430-line letterbox picture)

$-36 \leq n \leq 250$ (non-PALplus MACP)

$$\begin{aligned}
 Y_{\text{out}}(60+n) = & 1/128 * (\\
 & 3 * Y_{\text{in}}(373+n-3) \\
 & - 6 * Y_{\text{in}}(60+n-2) \\
 & - 10 * Y_{\text{in}}(373+n-2) \\
 & + 18 * Y_{\text{in}}(60+n-1) \\
 & + 59 * Y_{\text{in}}(373+n-1) \\
 & + 59 * Y_{\text{in}}(60+n) \\
 & + 18 * Y_{\text{in}}(373+n) \\
 & - 10 * Y_{\text{in}}(60+n+1) \\
 & - 6 * Y_{\text{in}}(373+n+1) \\
 & + 3 * Y_{\text{in}}(60+n+2))
 \end{aligned}$$

$$Y_{\text{out}}(372+n) = Y_{\text{out}}(60+n)$$

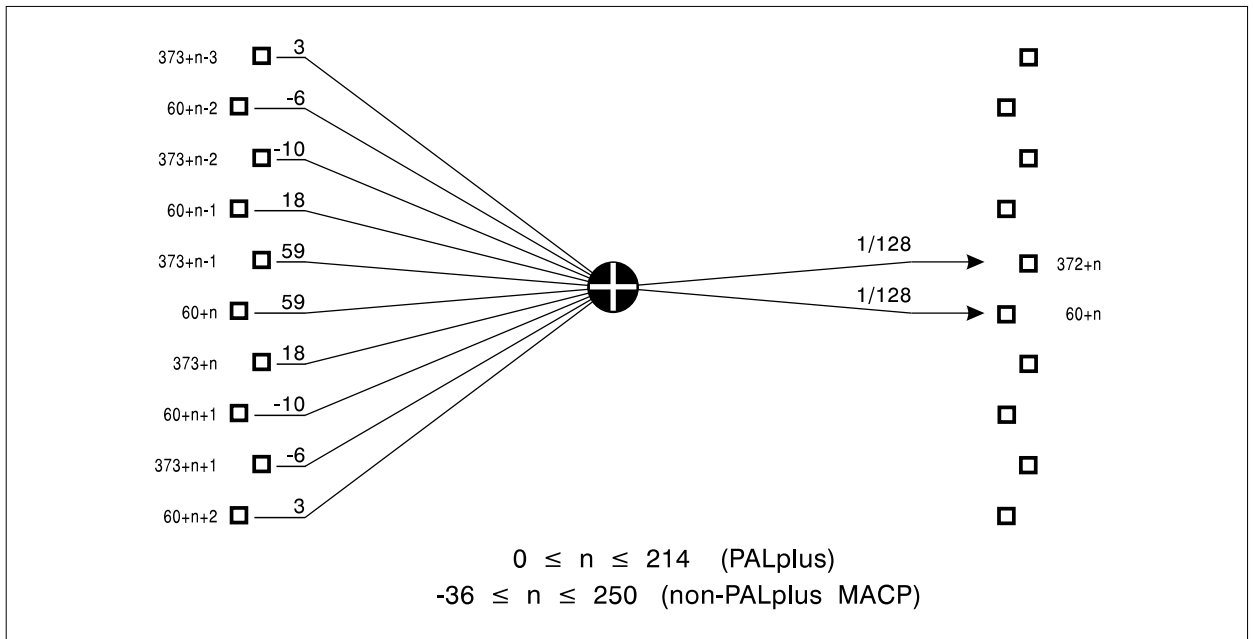

NOTE 1: This drawing illustrates the operation of the entire high-frequency luminance intra-frame averaging process shown in figure 12.

NOTE 2: For PALplus: input frame of 430 lines → two identical fields of 215 lines.

NOTE 3: For non-PALplus MACP: input frame of 574 lines → two identical fields of 287 lines.

Figure A.8: ENC_Y_IFA

A.4.3 ENC_UV_LPF

(Encoder colour-difference low-pass filters, pre-filtering prior to Motion Adaptive Colour Plus processing, see figure 11)

The **recommended** filter coefficients (see subclause 6.3.1) are as follows:

(in = out = 6,75 MHz)

15 taps, sum = 256

<122> 77 5 -16 -3 4 1 -1

A.4.4 VERT_IFA

(Intra-frame averaging filter, see figure 13)

Sampling grid in: frame based

430 lines (PALplus) or 574 lines (non-PALplus MACP)

Sampling grid out: field based

215 lines (PALplus) or 287 lines (non-PALplus MACP)

2 taps, sum = 2

1 1

NOTE: This filter is even-symmetrical.

The filter shall be applied as shown in figure A.9 and as follows:

$$0 \leq n \leq 214 \text{ (PALplus 430-line letterbox picture)}$$

$$-36 \leq n \leq 250 \text{ (non-PALplus MACP)}$$

$$Y_{out}(60+n) = 1/2 * (Y_{in}(372+n) + Y_{in}(60+n))$$

$$Y_{out}(372+n) = Y_{out}(60+n)$$

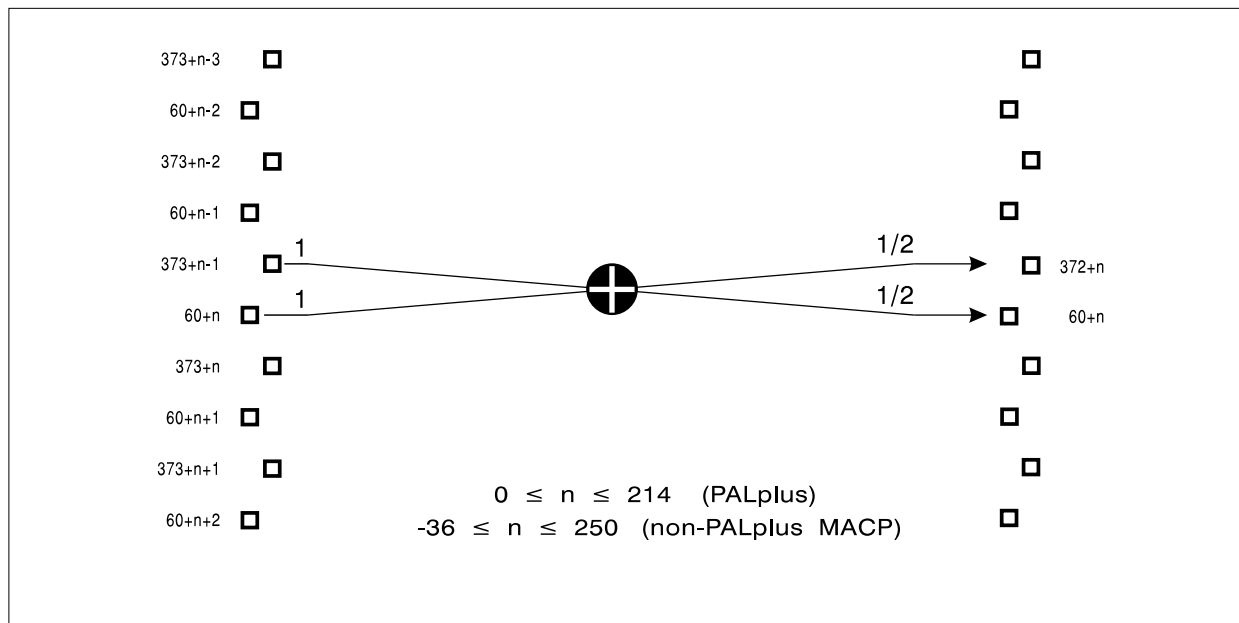

NOTE: This drawing illustrates the operation of the intra-frame averaging process, including the associated field delays shown in figures 12 and 13.

Figure A.9: VERT_IFA

A.4.5 ENC_MD_UV_LPF

(Encoder motion detector chain colour-difference signal filters, see figure 14)

(in = out = 6,75 MHz)

13 taps, sum = 256

<56> 49 35 18 5 -3 -4

A.4.6 ENC_M_US

(Encoder motion detector motion signal up-sampling filter, see figure 14)

(up-sample by 2: in = 6,75 MHz, out = 13,5 MHz)

3 taps, sum = 4, sum per phase = 2

<2> 1

A.4.10 LUT_ENC_MD_YL

(Look-up table in motion detector chain: generation of IFA high-frequency luminance level control signal L, see figure 14)

Input value M	0	1	2	3	4	5	6	7	8	9	10	11	12	13	14	15
Output value (4 * L)	4	4	4	4	4	4	4	4	3	2	1	0	0	0	0	0

A.4.11 LUT_ENC_MD_CS

(Look-up table in motion detector chain: generation of IFA chrominance switching control signal S, see figure 14)

Input value M	0	1	2	3	4	5	6	7	8	9	10	11	12	13	14	15
Output value (4 * S)	0	0	0	0	0	0	0	0	0	0	0	0	0	0	4	4

A.5 PAL encoding

A.5.1 ENC_UV_US

(Colour-difference signal up-sampling filters, see figure 16)

(up-sample by 2: in = 6,75 MHz, out = 13,5 MHz)

15 taps, sum = 512, sum per phase = 256

<256> 158 0 -41 0 13 0 -2

Annex B (informative): Encoder filter plots

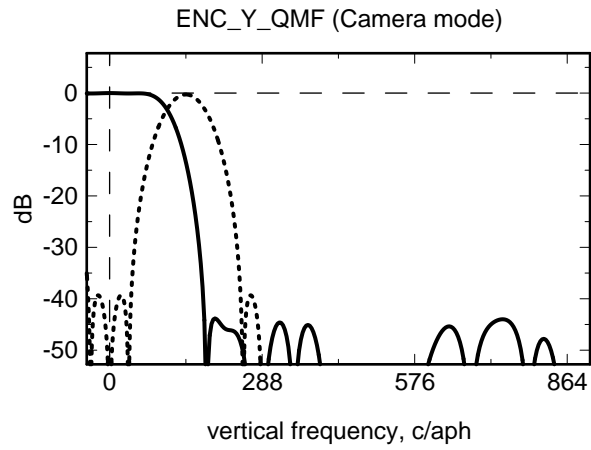

Figure B.1

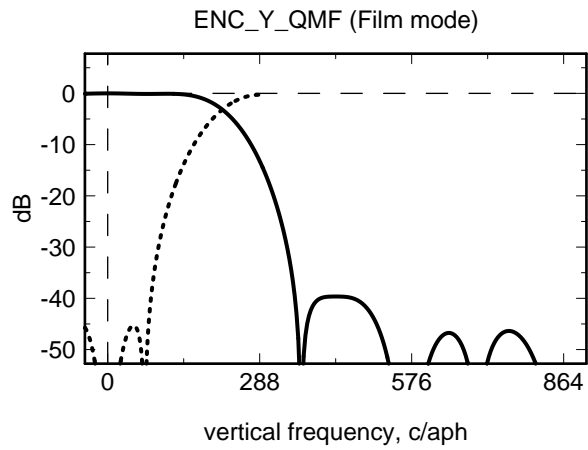

Figure B.2

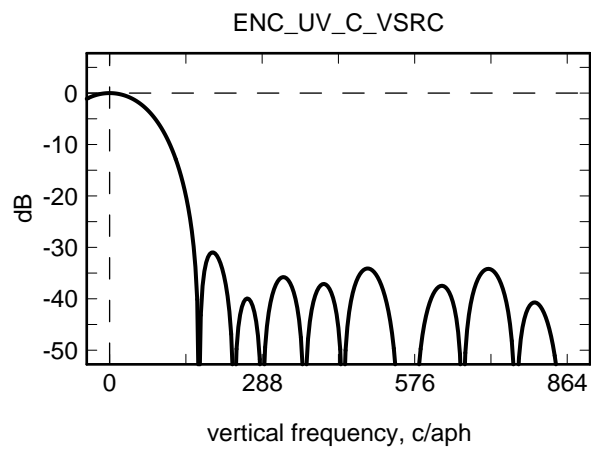

Figure B.3

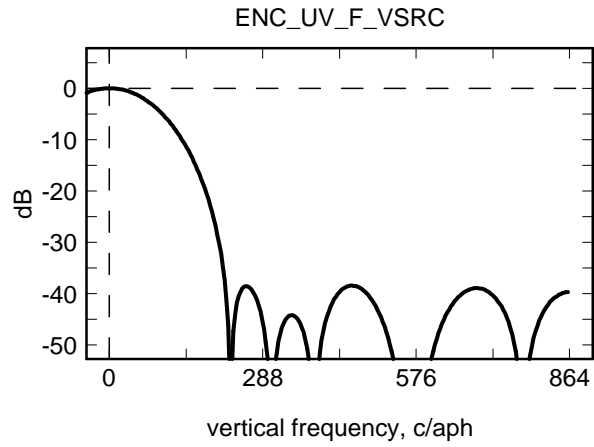

Figure B.4

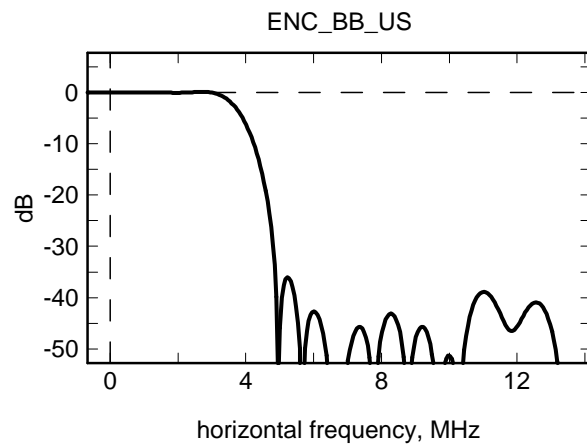

Figure B.5

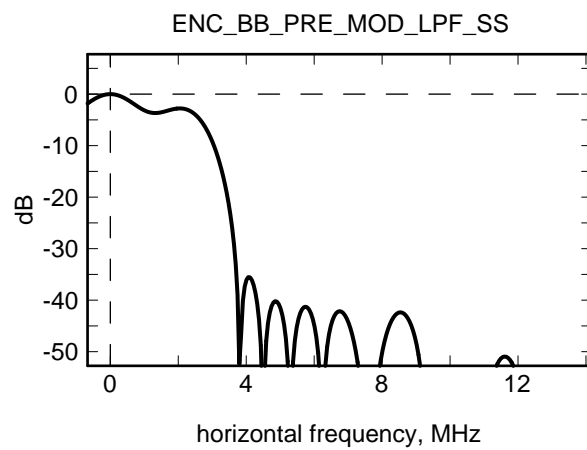

Figure B.6

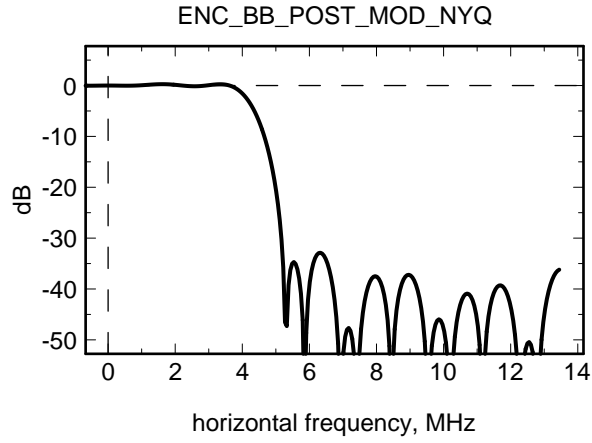

Figure B.7

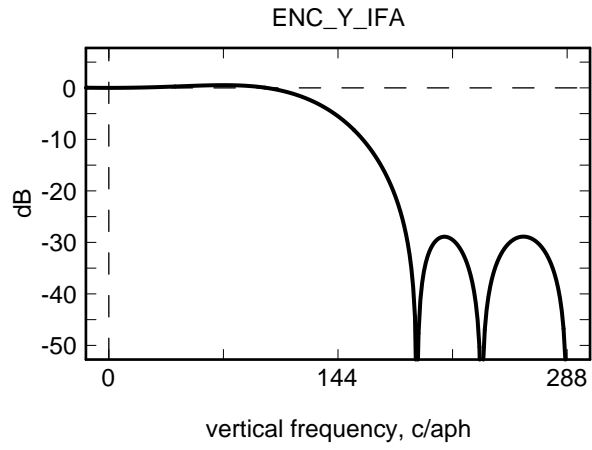

Figure B.8

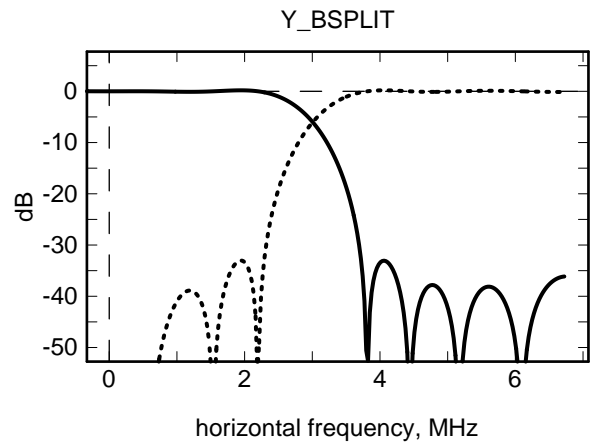

Figure B.9

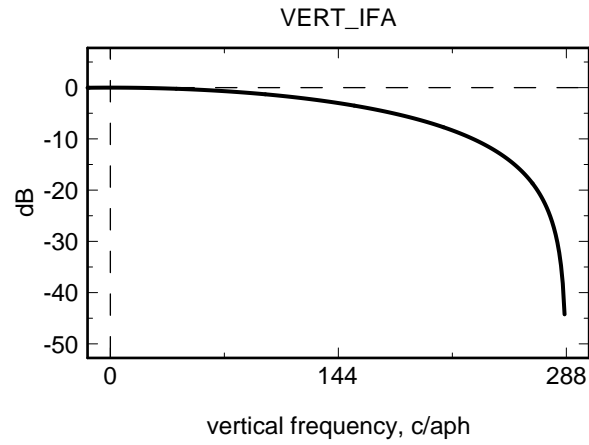

Figure B.10

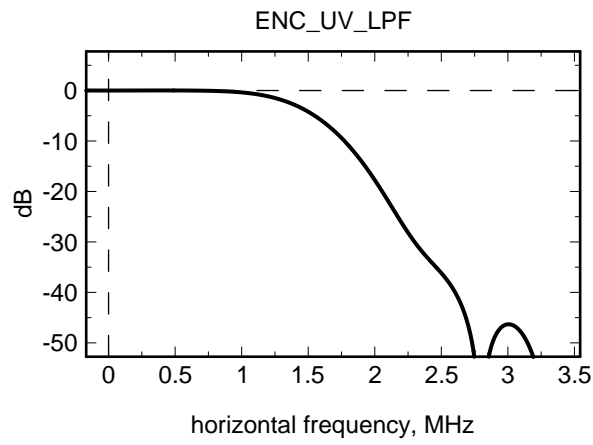

Figure B.11

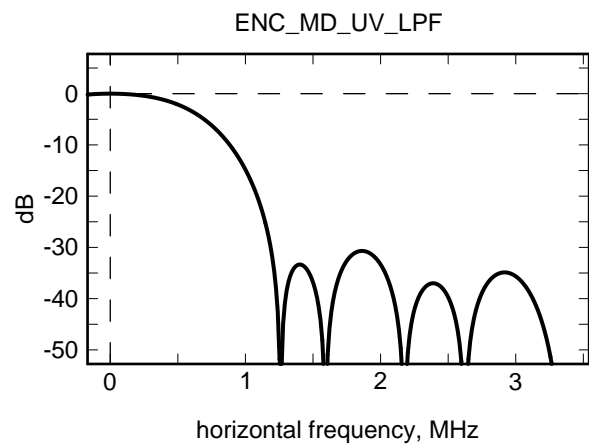

Figure B.12

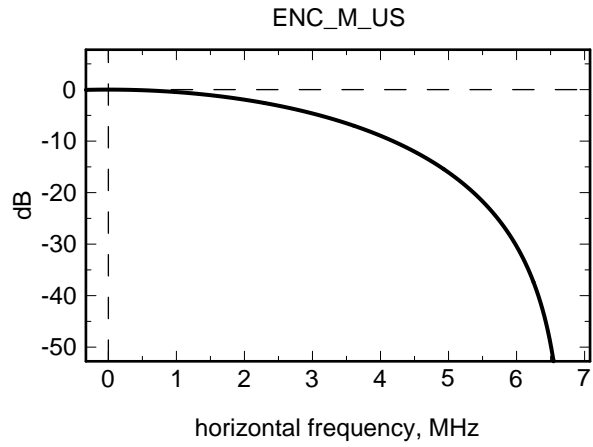

Figure B.13

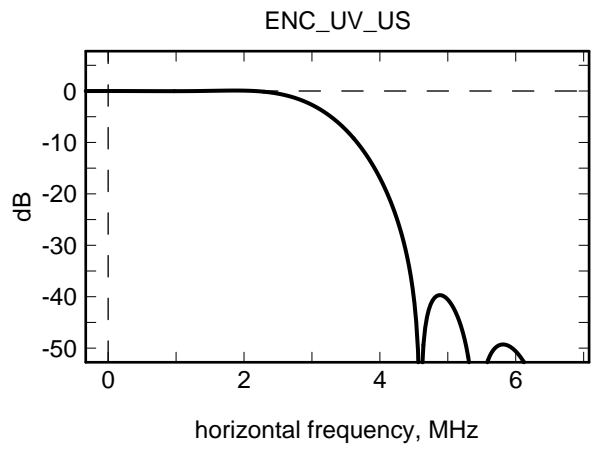
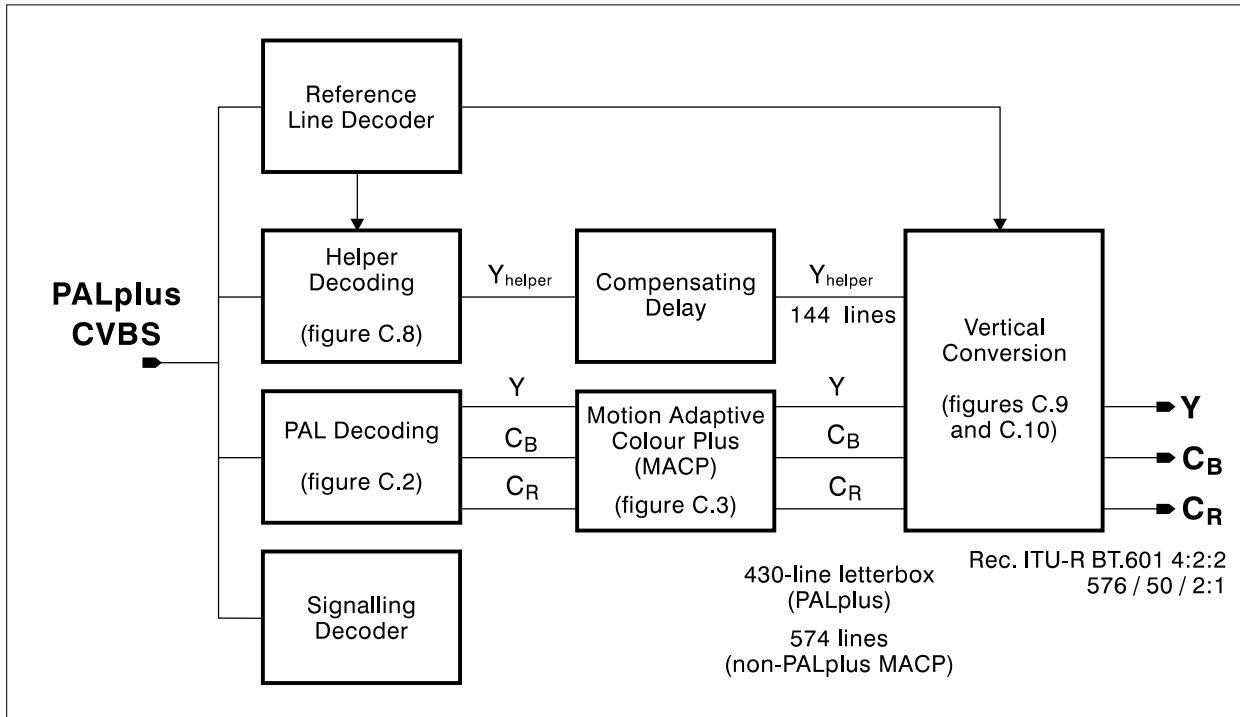

Figure B.14

Annex C (informative): The PALplus decoder

C.1 General

Figure C.1 is a top level block diagram of a reference PALplus decoder. In this example, all processing takes place in digital form using line-locked sampling rates of 13,5 MHz, 27 MHz and 6,75 MHz.



NOTE: Helper not used with non-PALplus MACP.

Figure C.1: Outline of PALplus decoding processes

C.1.1 Composite PALplus input signal

In this example, the input to the decoder is first converted to a digital composite PALplus signal with the following characteristics:

Sampling rate: 13,5 MHz, quantizing range: $0,00_{10}$ to $255,75_{10}$ (unsigned),

10-bit resolution. Black level = $64,00_{10}$, peak white level = $192,00_{10}$.

The quantizing range is as illustrated in figure 4. The format of the signal is identical to the digital output of the PALplus encoder, see subclause 5.2.

(Using the above quantizing scale, the maximum peak-to-peak amplitudes of the modulated chrominance signals are: $U = 112,00_{10}$, $V = 157,50_{10}$).

C.1.2 Decoder output signal

The decoder produces 625-line interlaced digital $YC_B C_R$ signals with sampling rates corresponding to those of ITU-R Recommendation BT.601-5 [1], with an aspect ratio of 16:9.

The total delay in the decoding process is the same in both camera mode and in film mode. Decoders in receivers may incorporate appropriate compensating delays for the audio signals.

C.2 Overview of the PALplus decoding process

The 10-bit digital composite input signal is taken both to the PAL Decoding block (figure C.2) and to the Helper Decoding block (figure C.8).

The PAL Decoding process (see annex C, figure C.2) performs demodulation of the chrominance signals, and produces 8-bit $C_B C_R$ signals sampled at 6,75 MHz, together with luminance (10-bit resolution, sampled at 13,5 MHz) delayed by an appropriate amount to compensate for the chrominance paths. At this stage, the $Y C_B C_R$ signals still contain PAL artefacts.

The 430-line letterbox $Y C_B C_R$ signals from the PAL decoder are then Motion Adaptive Colour Plus post-processed (see annex C, figure C.3), resulting in 430-line letterbox $Y C_B C_R$ signals with greatly reduced PAL artefacts.

The Helper Decoder (see annex C, figure C.8) demodulates the vertical helper signal carried in the black bands, and provides 144 lines of vertical helper in baseband (all processing takes place at a rate of 13,5 MHz).

Finally, the Vertical Conversion process (see annex C, figures C.9 and C.10) combines the 430-line letterbox $Y C_B C_R$ signals with the vertical helper to produce a 576-active line 16:9 aspect ratio output signal with sampling rates according to ITU-R Recommendation BT.601-5 [1]. The Vertical Conversion process restores the vertical resolution of the 576-line source picture for horizontal frequencies up to approximately 3 MHz.

C.2.1 PAL decoding

The analogue composite video input signal first undergoes A-D conversion, to a 10-bit resolution (unsigned) signal at a rate of 13,5 MHz (quantizing scale = $0,00_{10}$ to $255,75_{10}$; black level = $64,00_{10}$, peak white = $192,00_{10}$, see figure 4 and subclause 5.2). This is the same form of digital composite signal as provided by the encoder.

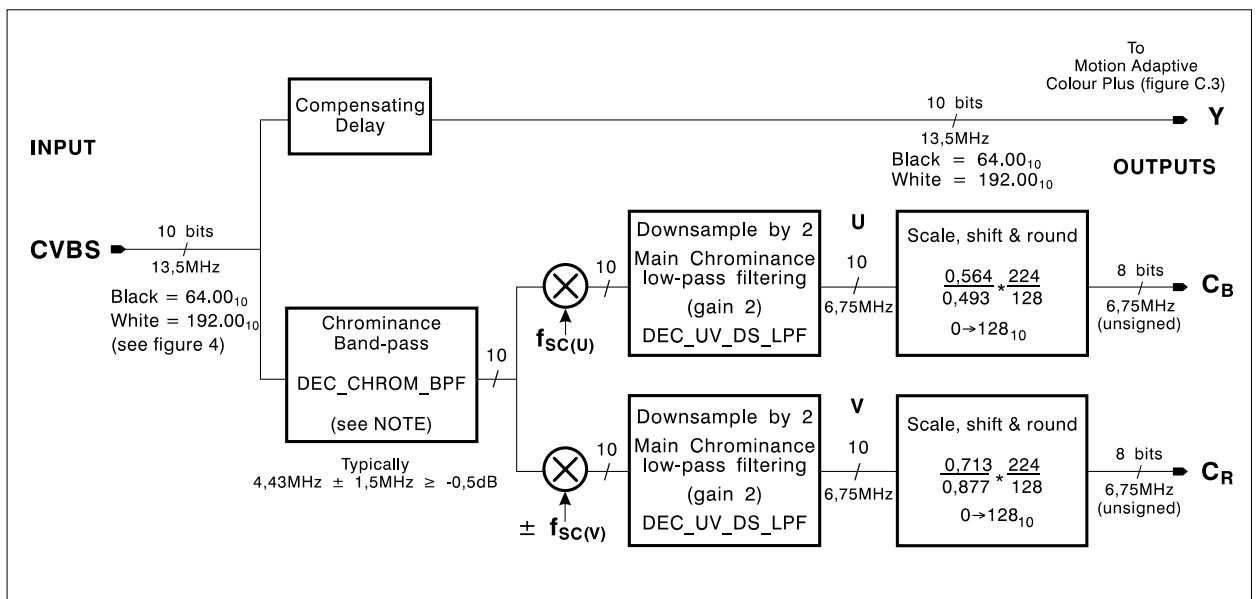

NOTE: Filter DEC_CHROM_BPF is not required if DEC_UV_DS_LPF is implemented as described in annex D, clause D.5; if present, it should not influence the filtering within the desired pass-band.

Figure C.2: PAL decoding

The received composite signal is split into two paths (see annex C, figure C.2):

- 1) A bandpass filter DEC_CHROM_BPF may precede demodulation of the U and V chrominance signals. This filter, together with the down-sampling by two filters following chrominance demodulation (DEC_UV_DS_LPF) may be used to perform the equivalent function to the low-pass filtering of C_B and C_R (shown as DEC_UV_LPF in figure C.3), in which case DEC_UV_LPF will not be required. In the example given, the necessary filtering is performed entirely by the down-sample filters, so that DEC_CHROM_BPF should be made sufficiently broadband so as not to influence the filtering within the desired pass-band.

It is not necessary to include a PAL delay line here, since a PAL delay line is incorporated in the subsequent chrominance vertical sample rate conversion process (performed by vertical filter DEC_UV_VSRC in figures C.9 and C.10). If a PAL delay line is included here, then vertical filter DEC_UV_VSRC_NDL should be used in place of DEC_UV_VSRC.

Scaling, shifting, and down-sampling results in 8-bit unsigned C_B and C_R output letterbox picture signals in the range 16_{10} - 240_{10} (ITU-R Recommendation BT.601-5 [1] format).

- 2) The Y signal is delayed to compensate for the chrominance processing.

Unlike processing in a standard PAL decoder, no subcarrier notch or comb filtering should be applied to the luminance signal. This is because the MACP process is designed to operate with a luminance signal having an essentially uniform and wide bandwidth, limited principally by the characteristics of the transmission system.

C.2.2 MACP post-processing

The incoming luminance signal from the PAL decoder is split by Y_BSPLIT into its high and low pass components (see annex C, figure C.3(a)). The high-pass luminance is subsequently intra-frame averaged (see annex C, figure C.4) and vertically filtered by DEC_Y_VAA to reduce staircase effects on diagonal lines (see annex C, figure C.3(a)). The amplitude of the intra-frame averaged luminance signal is controlled by the luminance control signal L generated by the motion detector chain (see annex C, subclause C.2.2.1). This turns off the IFA signal in areas of colour motion, to minimise cross-luminance. The controlled IFA luminance signal is added to the low-pass luminance signal to form the output luminance signal.

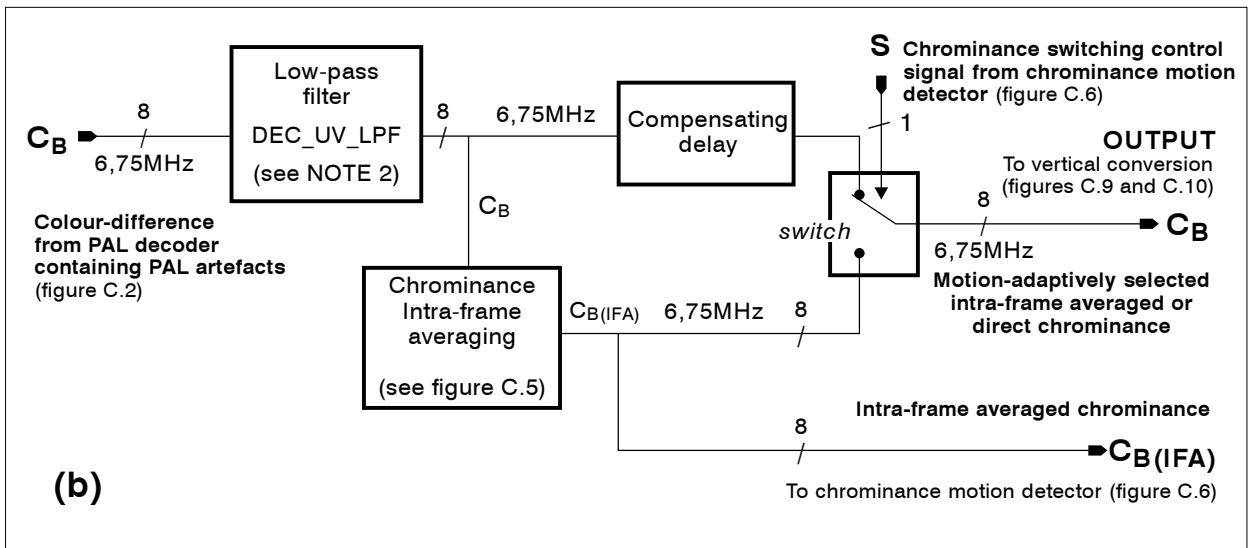
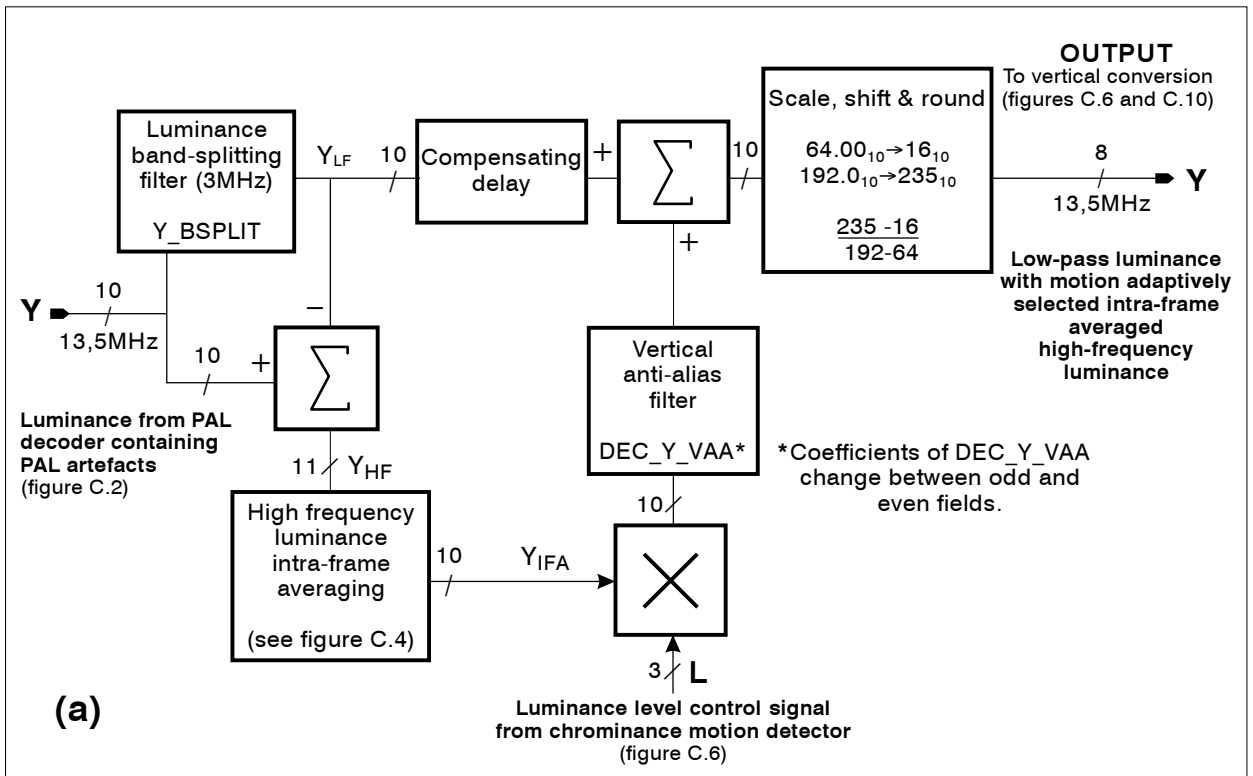

C3-033

- NOTE 1: The coefficients of filter DEC_Y_VAA change between odd and even fields.
- NOTE 2: Filter DEC_UV_LPF is not required if appropriate low-pass filtering has been carried out in the PAL decoder (figure C.2), see annex C, subclause C.2.1.
- NOTE 3: Processing of C_R is identical to that of C_B.

Figure C.3: Motion Adaptive Colour Plus decoding (a) luminance (b) chrominance

Figure C.3(b) shows the C_B path (C_R is treated identically). The C_B/C_R signals incoming from the PAL decoder should first be low-pass filtered to remove luminance components that would otherwise generate cross-colour, and this is performed conceptually by DEC_UV_LPF. (In addition to causing visible picture artefacts, any cross-colour might also be sent to the colour motion detector where it would cause spurious triggering). It should be noted that DEC_UV_LPF is not required if the PAL decoder incorporates appropriate filtering following chrominance demodulation (see annex C, subclause C.2.1). It should also be noted that in

the case of professional decoders, where it is known that additional filtering will take place prior to display by the consumer receiver, this filtering may be made flatter and sharper than that proposed in annex C, subclause C.2.1 and annex D, subclause D.4.3.

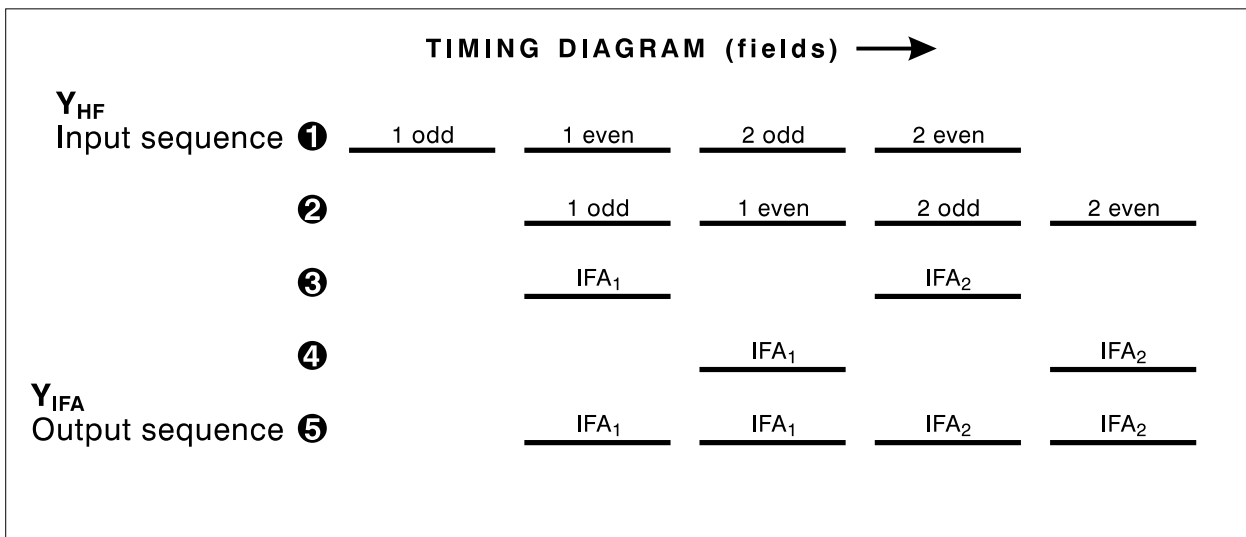
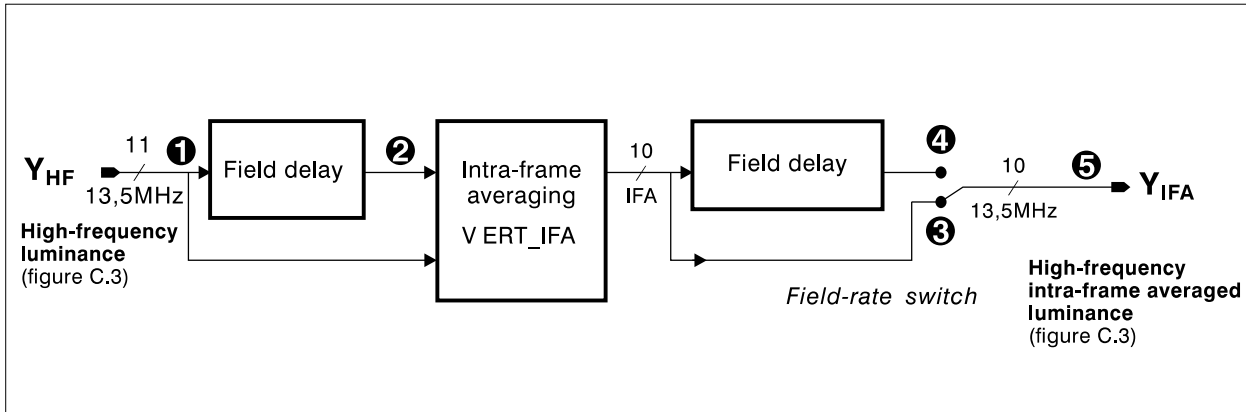

NOTE: IFA_n = field of intra-frame averaged signal averaged from odd and even fields of frame n.

Figure C.4: Motion Adaptive Colour Plus intra-frame averaging of high-frequency luminance

The C_B/C_R signals are then divided into two paths: one path undergoes intra-frame averaging, and the other merely a compensating delay. The intra-frame averaged C_B/C_R signal always contains colour information with a temporal content of 25 Hz. The direct signal may contain 50 Hz colour information (in moving areas of saturated colour) or it may contain cross colour only (in static areas of high frequency luminance in camera mode or in film mode).

The IFA colour difference signals are sent to the motion detector (see annex C, subclause C.2.2.1). The chrominance control signal S provided by the motion detector selects between the direct colour-difference signal path (with 50 Hz temporal content) and the intra-frame-averaged C_B/C_R outputs, such that 50 Hz colour information is made available in camera mode when necessary in order to avoid visible judder on highly saturated moving areas of colour.

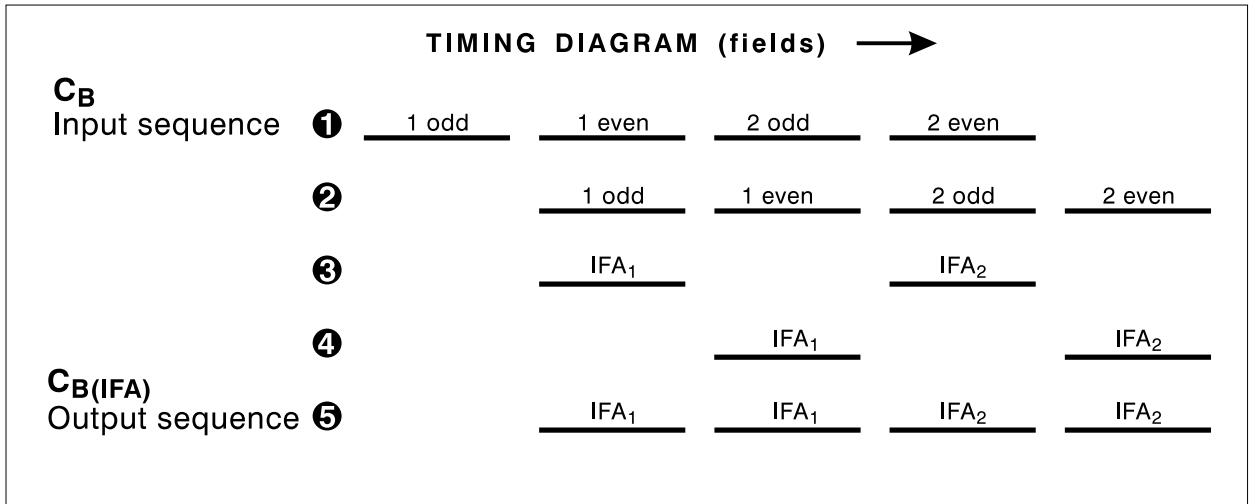
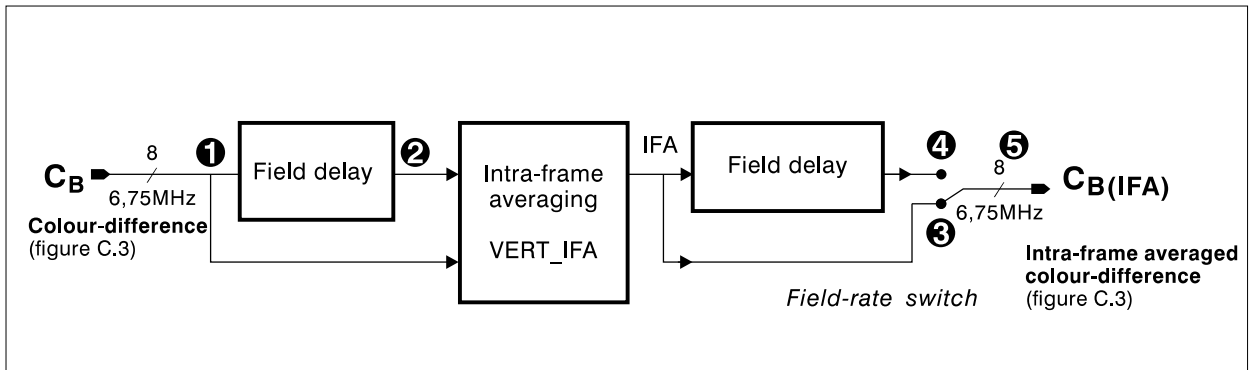

NOTE 1: Processing of C_R is identical to that of C_B.

NOTE 2: IFA_n = field of intra-frame averaged signal averaged from odd and even fields of frame n.

Figure C.5: Motion Adaptive Colour Plus intra-frame averaging of chrominance

C.2.2.1 Motion detector operation

The structure of the motion detector in the reference decoder is identical to that of the encoder, and is illustrated in figure C.6. Other implementations of the decoder, perhaps using different sampling rates for some processes, might be possible.

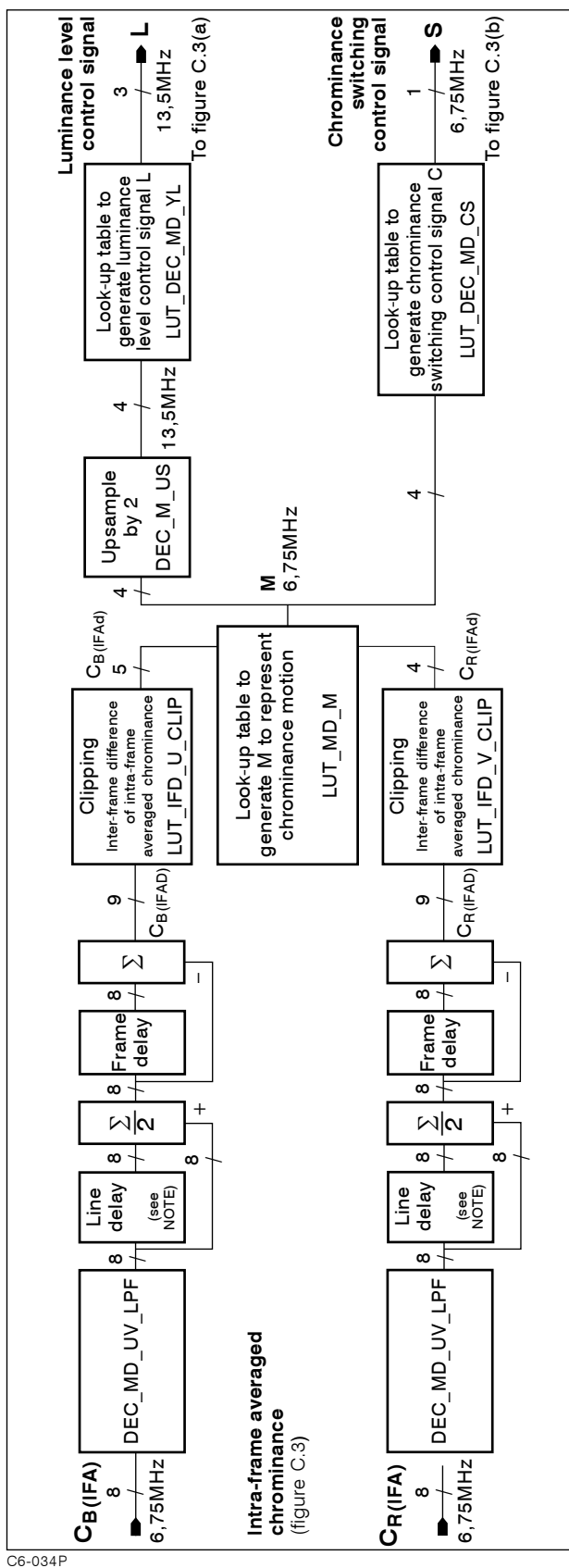

NOTE: A PAL delay line may not be required here if PAL delay line processing has been incorporated at an earlier stage.

Figure C.6: Motion detector operation

The incoming intra-frame averaged chrominance signals $C_{B(IFA)}$ and $C_{R(IFA)}$ are first low-pass filtered by filter DEC_MD_UV_LPF, to ensure that the motion detector operates on signals with comparable bandwidths in both the decoder and the encoder.

NOTE 1: Filter DEC_MD_UV_LPF in the position shown in figure C.6 may be omitted if appropriate filtering has taken place in an earlier stage of processing.

The signals then enter a PAL delay line. This prevents differential phase errors from affecting the motion detector.

NOTE 2: A delay line is not required in the position shown in figure C.6 if PAL delay line processing has been incorporated at an earlier stage.

The signals at the output of the delay line are $C_{B(IFA)}$ and $C_{R(IFA)}$. A frame delay is then used to calculate $C_{B(IFAD)}$ and $C_{R(IFAD)}$, the inter-frame difference of each of the intra-frame averaged chrominance signals.

The motion signal M is derived in an identical manner to that in the encoder, see subclause 6.3.2. This motion signal is converted to a sample rate of 13,5 MHz by filter DEC_M_US prior to derivation of the luminance control signal.

Further ROMs LUT_DEC_MD_YL and LUT_DEC_MD_CS are used to scale and clip the motion signal M to produce the desired luminance control signal L and chrominance control signal S using the following functions:

$$L = 4*(13-M) \text{ where } L \text{ is clipped and scaled such that } 0 \leq L \leq 1$$

NOTE 3: The five possible values of the 3-bit level control signal represent the multiplication factors of 0, 1/4, 1/2, 3/4, and 1 respectively.

$$S = (M-13) \text{ where } S \text{ is clipped such that } 0 \leq S \leq 1$$

This results in a hard switch for S , and five possible levels for L , in both the encoder and decoder. This is illustrated in figure 15 for the encoder, and in figure C.7 for the reference decoder.

A control signal of value 0 means that the control signal will subsequently switch off the signal that is being controlled, while the maximum values of 1 for L and S imply the full amplitudes of the controlled signals.

It should be noted that it is a receiver manufacturer's option to choose whether to implement hard or soft switching for the luminance control signal L in the decoder. If hard-switching is used, the threshold value for M should be chosen as 11, such that the control signal $L=1$ for $M < 11$ and $L=0$ for $M \geq 11$.

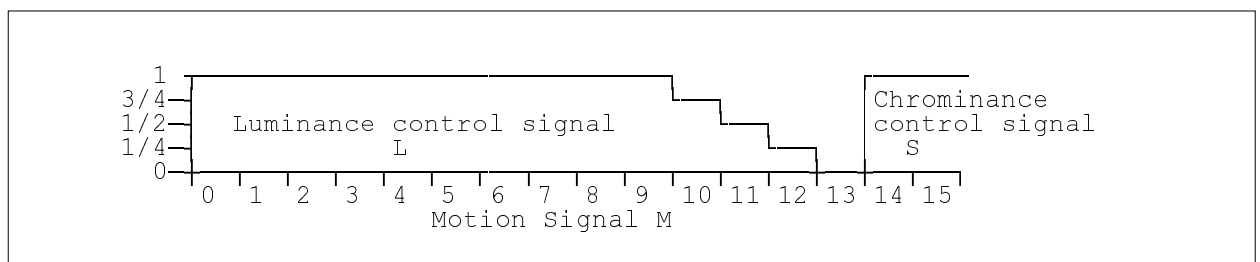

Figure C.7: Derivation of luminance level control (in the case of soft-switching) and chrominance switching signals in the decoder from the chrominance motion signal M

The effect of the control signals is that as the encoder motion signal M increases (see figure 15), L is first used in the encoder to turn high-frequency luminance off, then the decoder high-frequency luminance is turned off, and then the direct chrominance signal is turned on in both the encoder and the decoder.

This order of operations ensures that the system contains minimal cross effects; setting the luminance control threshold higher in the decoder than in the encoder means that any noise in the receiver which might cause the decoder to switch in and out of the Colour Plus mode will cause this to happen when no high-frequency luminance has been encoded, and will therefore be less visible.

C.2.3 Helper processing

All helper processing in the encoder is performed at 27 MHz, since this is advantageous in minimising alias products. In the decoder, processing at 27 MHz gives no advantage, and all decoder processing may be carried out at 13,5 MHz .

Referring to figure C.8, the helper signal is first filtered by pre-demodulation filter DEC_BB_PRE_MOD (in practice, this would not be required in System B/G, where the necessary 5 MHz filtering has already been performed at IF). In the case of System I, in which a wider receiver IF filter may be used, DEC_BB_PRE_MOD should provide additional filtering in order to avoid the introduction of additional noise (see annex D, subclause D.3.1).

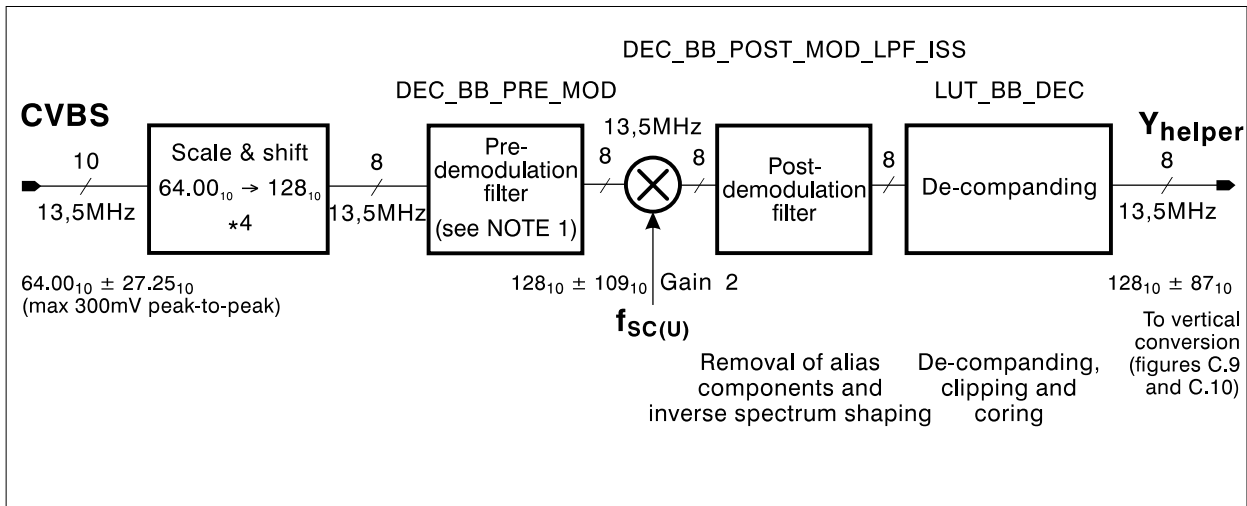

- NOTE 1: Filter DEC_BB_PRE_MOD may be omitted in some circumstances (see annex C, subclause C.2.3, annex D, and filter plot in annex E).
- NOTE 2: If used, helper gain control derived from the reference signal in Line 23 should be applied prior to de-companding.

Figure C.8: Helper decoding

The signal is then demodulated by multiplying it with the U-phase of the colour subcarrier (sampled at 13,5 MHz). Post-demodulation filter DEC_BB_POST_MOD_LPF_ISS removes alias components, and provides the inverse shaping to that carried out by encoder filter ENC_BB_PRE_MOD_LPF_SS. The de-companding process is performed by LUT_BB_DEC. (Both LUT_BB_ENC in the encoder and LUT_BB_DEC in the decoder include clipping and coring).

The following scaleable formula is used to derive values for the decompander look-up table LUT_BB_DEC given in annex A:

$$y' = y / AmplFactor$$

$$IF y' \leq 0,12 * Yrange THEN x' = 0$$

$$IF y' > 0,12 * Yrange THEN x' = Xrange \left((p4 + p3) * \left[\frac{y'}{Yrange} * (1 - p2) + p2 \right]^{\frac{1}{p1}} - p3 \right)$$

$$x = MIN [x', 0.80 * Yrange]$$

where:

- x is the absolute non-companded value and y is the absolute companded value;
- p1 = 0,0010; p2 = 0,9977126; p3 = 0,07477; p4 = 0,79981;

- AmplFactor = 1 (camera mode), AmplFactor = 2 (film mode);
- the ranges are indicated with X_{range} and Y_{range} (both are 109).

NOTE 1: The DC-shift (128_{10}) is not included in the above formula.

NOTE 2: The companding curve is symmetrical about zero, such that negative values for x and y are derived directly from the absolute values provided by the formula.

In film mode, the de-companding curve has an attenuation factor of 6 dB compared to camera mode, thereby greatly reducing the visibility of noise contributed via the helper chain. This is illustrated in figure 10(b), while the combined effects of the compander and de-compander are shown in figure 10(c).

In the decoder, scaling is first performed to restore the helper range to $128_{10} \pm 109$. After demodulation by multiplication with the U phase of the colour subcarrier, a multiplication by 2 should be performed (otherwise modulation and subsequent demodulation would halve the amplitude of the wanted signal). Before demodulation, the set-up (128_{10}) is subtracted (the range becomes -109_{10} to $+109_{10}$) and after demodulation the set-up (128_{10}) should be added to the signal again (range is $128_{10} \pm 109_{10}$).

C.2.4 Vertical conversion of luminance

The luminance vertical conversion process in the decoder is similar to that of the encoder, and is shown in figures C.9 and C.10 for film and camera mode respectively. The QMF filtering process is shown in figure C.11.

The vertical conversion processes assume 432 letterbox picture lines per frame (a ratio of 4 to 3 to produce 576 active picture lines per frame). However, incoming lines 59 and 587 do not carry letterbox picture information, and these lines are not stored in memories M6, M7 and M8 (see annex C, figures C.9 and C.10). When samples from these lines are required, rather than using the outputs from memories M6, M7 and M8, black level ($Y=16_{10}$, $C_B=C_R=128_{10}$) is instead applied to the inputs to the decoder luminance QMF and chrominance vertical sample rate conversion processes.

The luminance QMF process to create 288-line fields (see annex C, figure C.11) theoretically requires input signals with a few more than the available 215 lines of picture and 72 lines of helper per field (stored in memories M6A/B and M7A/B) for reconstruction of the first and last few lines of each field; black level ($Y=16_{10}$) should therefore be applied to the luminance QMF input for any "missing" lines of letterbox picture and zero-level (set-up of 128_{10}) for "missing" helper lines.

C.2.5 Vertical conversion of chrominance

In camera mode, intra-field vertical sample rate conversion is carried out (see annex C, figure C.9). In film mode, the same chrominance information is present on both fields of each frame and the same filter coefficients (DEC_UV_VSRC) are used (see annex C, figure C.10). Note that if a PAL delay line has previously been incorporated in the PAL decoding process, then a wider filter should be applied (an example is given as DEC_UV_VSRC_NDL in annex D; this is the letterbox part of the decoder luminance QMF filter).

The vertical conversion process theoretically requires input picture signals with a few more than the available 215 lines of picture per field (stored in memories M8A and M8B at the input to the vertical sample rate conversion process) for reconstruction of the first and last few lines of each field; black level ($C_B=C_R=128_{10}$) should therefore be applied to the chrominance signal vertical sample rate conversion inputs for any "missing" lines.

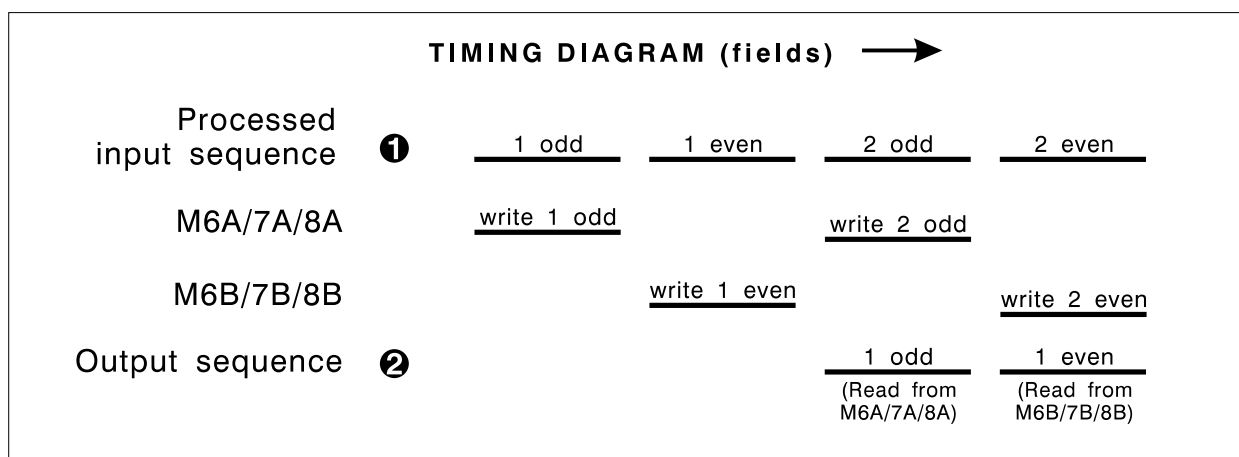
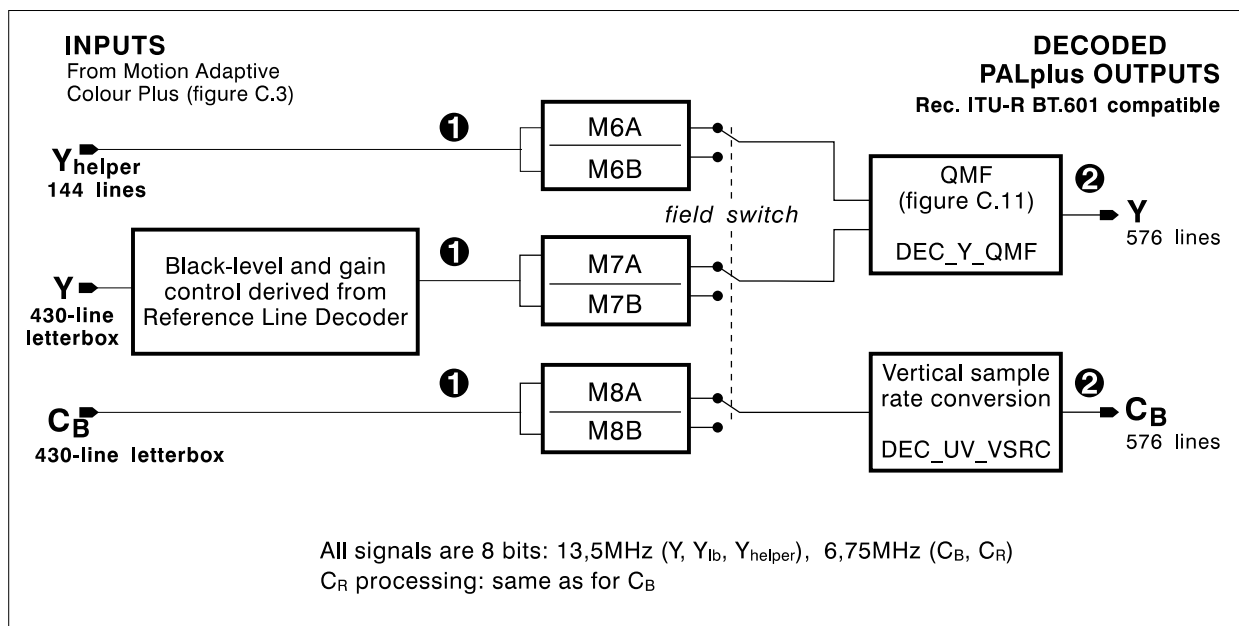

MEMORIES

M6A, M6B: 144 x 720 x 8
 M7A, M7B: 430 x 720 x 8
 M8A, M8B: 430 x 360 x 8 x (2)

C9-023

Figure C.9: Vertical conversion (camera mode)

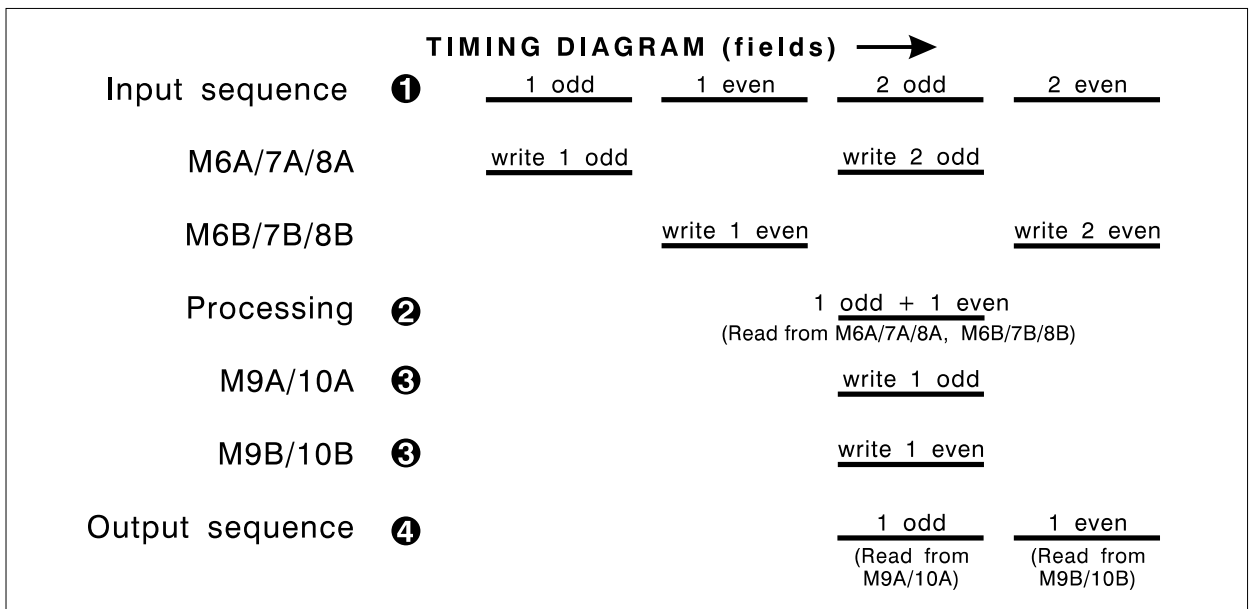
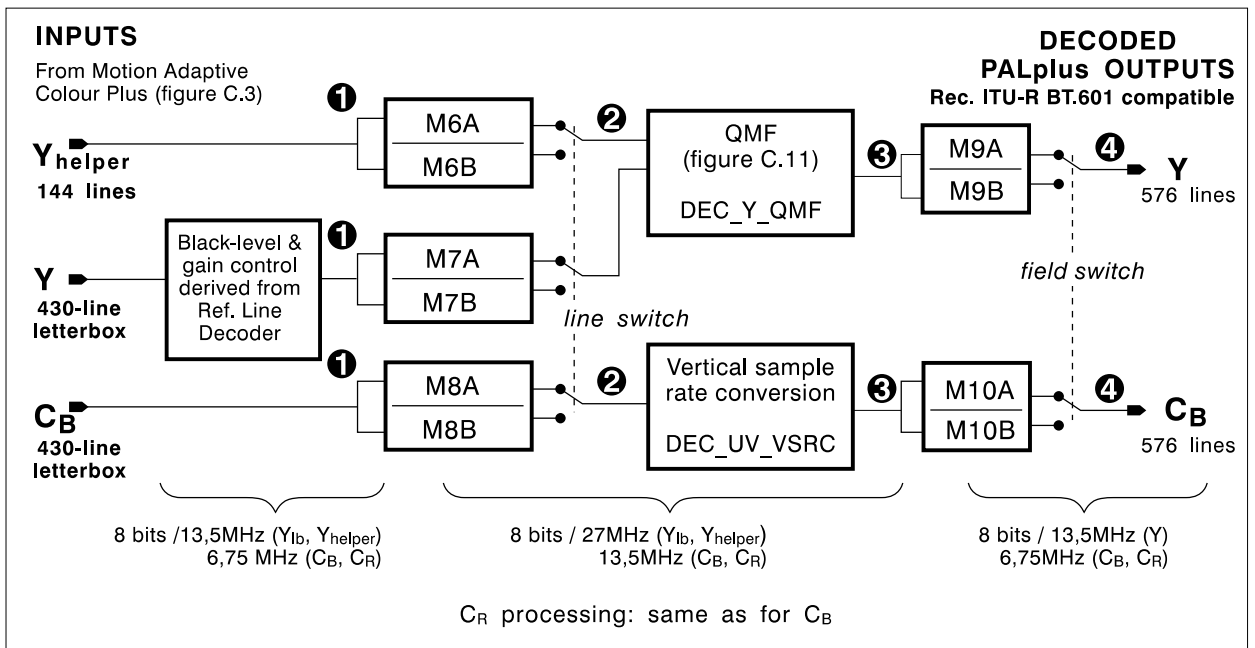

MEMORIES

M6A: 144 x 720 x 8	M6B: 72 x 720 x 8
M7A: 430 x 720 x 8	M7B: 215 x 720 x 8
M8A: 430 x 360 x 8 (x2)	M8B: 215 x 360 x 8 (x2)
M9A: 1 x 720 x 8	M9B: 288 x 720 x 8
M10A: 1 x 360 x 8 (x2)	M10B: 288 x 360 x 8 (x2)

C10-024

Figure C.10: Vertical conversion (film mode)

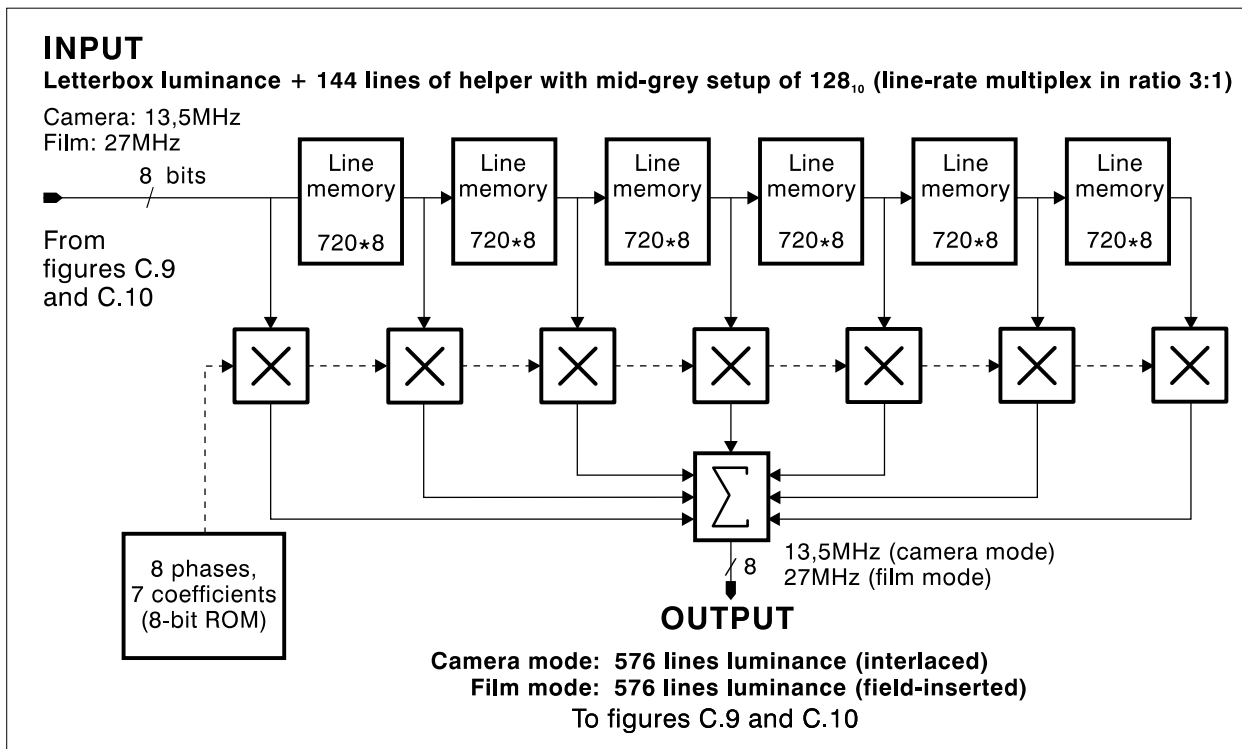

Figure C.11: Decoder QMF

C.2.6 Use of the Line 23/623 reference signals to assist vertical conversion

The reference signals may be used in the decoder to ensure accurate reconstruction of the 576-line luminance signal during the vertical conversion process. This is to reduce the effects of any errors that might be caused due to variations in the conventional PAL references in the signal during the transmission chain with respect to the levels of the luminance letterbox and helper signals; for example, colour burst and sync which originate in the PALplus encoder may subsequently be re-inserted during distribution and transmission.

The helper DC-level reference (black level for a normal PALplus signal) and amplitude of the helper reference burst in Line 23 (see figure 17) provide information for the setting of the DC-level and gain of the helper signal. These references can be processed by the helper decoder to give two reference DC-levels representing the "mid" level (no information carried by the helper) and the negative-going peak value of the helper. If used, they should be applied in the helper decoder prior to de-compressing.

Similarly, the black-level and white-level references in Line 623 (see figure 18) provide information for the accurate setting of the gain of the luminance signal prior to the vertical conversion process.

NOTE 1: The reference signals may optionally be present for non-PALplus MACP (see subclause 6.3.3), in which case they may be used to help achieve the correct setting of the amplitude of the incoming composite video signal.

NOTE 2: For standard PAL operation with no helper (WSS $b_5=0$ and $b_6=0$, see subclause 6.6), no assumptions should be made concerning the contents of the second half of Line 23 and the first half of Line 623.

Annex D (informative): Reference PALplus decoder: filter and look-up-table coefficients

D.1 General rules for filter descriptions

Most filters are odd-symmetrical, in which case the centre tap coefficient is given as <n>, together with one tail of coefficients.

In addition, where appropriate, the filtering operation is defined by reference to additional mathematical descriptions and diagrams.

D.1.1 General rules for horizontal filters

- each coefficient shall be in the range -256 to +255;
- the divider should be a power of 2.

D.1.2 General rules for vertical filters

- each coefficient shall be in the range -128 to +127;
- the divider should be a power of 2 and a maximum of 128.

Where mathematical descriptions are given, for each filter, the input signal is referred to as Y_{in} and the output signal as Y_{out} , irrespective of the nature of the signal (i.e., whether representing luminance, luminance vertical helper, or chrominance).

If an input signal is not contained within the active picture area, or the picture area defined to be valid for a particular filter, the value of the input signal shall be set to black (value 16_{10} in the case of luminance, 128_{10} for colour-difference signals and helper signals).

D.2 Vertical conversion

(See annex C, figures C.9 and C.10)

D.2.1 DEC_Y_QMF (camera mode)

(Decoder luminance 430 -> 576 line conversion - camera mode)

$$0 \leq n \leq 71 \text{ (valid input picture lines: 60 to 274 and 372 to 586)}$$

$$\text{if } n \leq 35 \text{ then } ad(n)=0$$

$$\text{else } ad(n)=215$$

NOTE: In practice, input helper lines have a mid-grey set-up of 128_{10} .

Phase 1:

$$Y_{out}(23+n*4) = 1/64 * (\begin{array}{l} 2 * Y_{in}(59+n*3-2) \\ - 6 * Y_{in}(59+n*3-1) \\ + 72 * Y_{in}(59+n*3) \\ - 6 * Y_{in}(59+n*3+1) \\ + 2 * Y_{in}(59+n*3+2) \\ + 17 * Y_{in}(24+n+ad(n-1)-1) \\ + 17 * Y_{in}(24+n+ad(n)) \end{array})$$

Phase 2:

$$Y_{out}(23+n*4+1) = 1/64 * (10 * Y_{in}(59+n*3) \\ + 62 * Y_{in}(59+n*3+1) \\ - 10 * Y_{in}(59+n*3+2) \\ + 2 * Y_{in}(59+n*3+3) \\ - 62 * Y_{in}(24+n+ad(n)))$$

Phase 3:

$$Y_{out}(23+n*4+2) = 1/64 * (1 * Y_{in}(59+n*3-1) \\ - 6 * Y_{in}(59+n*3) \\ + 37 * Y_{in}(59+n*3+1) \\ + 37 * Y_{in}(59+n*3+2) \\ - 6 * Y_{in}(59+n*3+3) \\ + 1 * Y_{in}(59+n*3+4) \\ + 90 * Y_{in}(24+n+ad(n)))$$

Phase 4:

$$Y_{out}(23+n*4+3) = 1/64 * (2 * Y_{in}(59+n*3) \\ - 10 * Y_{in}(59+n*3+1) \\ + 62 * Y_{in}(59+n*3+2) \\ + 10 * Y_{in}(59+n*3+3) \\ - 62 * Y_{in}(24+n+ad(n)))$$

Phase 5:

$$Y_{out}(336+n*4) = 1/64 * (1 * Y_{in}(372+n*3-2) \\ + 1 * Y_{in}(372+n*3-1) \\ + 69 * Y_{in}(372+n*3) \\ - 9 * Y_{in}(372+n*3+1) \\ + 2 * Y_{in}(372+n*3+2) \\ - 5 * Y_{in}(336+n+ad(n-1)-1) \\ - 38 * Y_{in}(336+n+ad(n)))$$

Phase 6:

$$\begin{aligned}
 Y_{out}(336+n*4+1) = 1/64 * (& -3 * Y_{in}(372+n*3-1) \\
 & + 24 * Y_{in}(372+n*3) \\
 & + 51 * Y_{in}(372+n*3+1) \\
 & - 9 * Y_{in}(372+n*3+2) \\
 & + 1 * Y_{in}(372+n*3+3) \\
 & + 82 * Y_{in}(336+n+ad(n)) \quad)
 \end{aligned}$$

Phase 7:

$$\begin{aligned}
 Y_{out}(336+n*4+2) = 1/64 * (& 1 * Y_{in}(372+n*3-1) \\
 & - 9 * Y_{in}(372+n*3) \\
 & + 51 * Y_{in}(372+n*3+1) \\
 & + 24 * Y_{in}(372+n*3+2) \\
 & - 3 * Y_{in}(372+n*3+3) \\
 & - 82 * Y_{in}(336+n+ad(n)) \quad)
 \end{aligned}$$

Phase 8:

$$\begin{aligned}
 Y_{out}(336+n*4+3) = 1/64 * (& 2 * Y_{in}(372+n*3) \\
 & - 9 * Y_{in}(372+n*3+1) \\
 & + 69 * Y_{in}(372+n*3+2) \\
 & + 1 * Y_{in}(372+n*3+3) \\
 & + 1 * Y_{in}(372+n*3+4) \\
 & + 38 * Y_{in}(336+n+ad(n)) \\
 & + 5 * Y_{in}(336+n+ad(n)+1) \quad)
 \end{aligned}$$

See also annex A, figures A.1, A.2 and A.3.

D.2.2 DEC_Y_QMF (film mode)

(Decoder luminance 430 -> 576 line conversion - film mode)

$0 \leq n \leq 71$ (valid input lines: 60 to 274 and 372 to 586)

if $n \leq 35$ then $ad(n)=0$

else $ad(n)=215$

NOTE: In practice, input helper lines have a mid-grey set-up of 128_{10} .

Phase 1:

$$Y_{out}(23+n*4) = 1/64 * (\begin{aligned} & 2 * Y_{in}(59+n*3-1) \\ & - 6 * Y_{in}(372+n*3-1) \\ & + 72 * Y_{in}(59+n*3) \\ & - 6 * Y_{in}(372+n*3) \\ & + 2 * Y_{in}(59+n*3+1) \\ & + 17 * Y_{in}(336+n+ad(n-1)-1) \\ & + 17 * Y_{in}(24+n+ad(n)) \end{aligned})$$

Phase 2:

$$Y_{out}(336+n*4) = 1/64 * (\begin{aligned} & 10 * Y_{in}(59+n*3) \\ & + 62 * Y_{in}(372+n*3) \\ & - 10 * Y_{in}(59+n*3+1) \\ & + 2 * Y_{in}(372+n*3+1) \\ & - 62 * Y_{in}(24+n+ad(n)) \end{aligned})$$

Phase 3:

$$Y_{out}(23+n*4+1) = 1/64 * (\begin{aligned} & 1 * Y_{in}(372+n*3-1) \\ & - 6 * Y_{in}(59+n*3) \\ & + 37 * Y_{in}(372+n*3) \\ & + 37 * Y_{in}(59+n*3+1) \\ & - 6 * Y_{in}(372+n*3+1) \\ & + 1 * Y_{in}(59+n*3+2) \\ & + 90 * Y_{in}(24+n+ad(n)) \end{aligned})$$

Phase 4:

$$\begin{aligned}
 Y_{out}(336+n*4+1) = 1/64 * (& 2 * Y_{in}(59+n*3) \\
 & - 10 * Y_{in}(372+n*3) \\
 & + 62 * Y_{in}(59+n*3+1) \\
 & + 10 * Y_{in}(372+n*3+1) \\
 & - 62 * Y_{in}(24+n+ad(n)))
 \end{aligned}$$

Phase 5:

$$\begin{aligned}
 Y_{out}(23+n*4+2) = 1/64 * (& 2 * Y_{in}(372+n*3) \\
 & - 6 * Y_{in}(59+n*3+1) \\
 & + 72 * Y_{in}(372+n*3+1) \\
 & - 6 * Y_{in}(59+n*3+2) \\
 & + 2 * Y_{in}(372+n*3+2) \\
 & + 17 * Y_{in}(24+n+ad(n)) \\
 & + 17 * Y_{in}(336+n+ad(n)))
 \end{aligned}$$

Phase 6:

$$\begin{aligned}
 Y_{out}(336+n*4+2) = 1/64 * (& 10 * Y_{in}(372+n*3+1) \\
 & + 62 * Y_{in}(59+n*3+2) \\
 & - 10 * Y_{in}(372+n*3+2) \\
 & + 2 * Y_{in}(59+n*3+3) \\
 & - 62 * Y_{in}(336+n+ad(n)))
 \end{aligned}$$

Phase 7:

$$\begin{aligned}
 Y_{out}(23+n*4+3) = 1/64 * (& 1 * Y_{in}(59+n*3+1) \\
 & - 6 * Y_{in}(372+n*3+1) \\
 & + 37 * Y_{in}(59+n*3+2) \\
 & + 37 * Y_{in}(372+n*3+2) \\
 & - 6 * Y_{in}(59+n*3+3) \\
 & + 1 * Y_{in}(372+n*3+3) \\
 & + 90 * Y_{in}(336+n+ad(n)))
 \end{aligned}$$

Phase 8:

$$\begin{aligned}
 Y_{out}(336+n*4+3) = 1/64 * (& 2 * Y_{in}(372+n*3+1) \\
 & - 10 * Y_{in}(59+n*3+2) \\
 & + 62 * Y_{in}(372+n*3+2) \\
 & + 10 * Y_{in}(59+n*3+3) \\
 & - 62 * Y_{in}(336+n+ad(n)))
 \end{aligned}$$

See also annex A, figures A.4 and A.5.

D.2.3 DEC_UV_VSRC

(Decoder colour-difference signal Vertical Sample Rate Conversion, if no PAL delay line has previously been included in the PAL decoding process)

Sampling grid in: field based, 215 lines

Sampling grid out: field based, 288 lines

31 taps, sum = 1024, sum per phase = 128

<68> 72 74 76 76 72 62 49 30 15 2 -8 -12 -12 -10 -8

The filter is applied as shown below:

$0 \leq n \leq 71$ (valid input lines: 60 to 274 and 372 to 586)

Phase 1:

$$Y_{out}(23+n*4) = 1/128 * (30 * Y_{in}(59+n*3-1) + 68 * Y_{in}(59+n*3) + 30 * Y_{in}(59+n*3+1))$$

Phase 2:

$$Y_{out}(23+n*4+1) = 1/128 * (-10 * Y_{in}(59+n*3-1) + 62 * Y_{in}(59+n*3) + 74 * Y_{in}(59+n*3+1) + 2 * Y_{in}(59+n*3+2))$$

Phase 3:

$$Y_{out}(23+n*4+2) = 1/128 * (-12 * Y_{in}(59+n*3) + 76 * Y_{in}(59+n*3+1) + 76 * Y_{in}(59+n*3+2) - 12 * Y_{in}(59+n*3+3))$$

Phase 4:

$$Y_{out}(23+n*4+3) = 1/128 * (2 * Y_{in}(59+n*3+1) + 74 * Y_{in}(59+n*3+2) + 62 * Y_{in}(59+n*3+3) - 10 * Y_{in}(59+n*3+4))$$

Phase 5:

$$\begin{aligned}
 Y_{out}(336+n*4) = 1/128 * (& -8 * Y_{in}(372+n*3-2) \\
 & + 49 * Y_{in}(372+n*3-1) \\
 & + 72 * Y_{in}(372+n*3) \\
 & + 15 * Y_{in}(372+n*3+1))
 \end{aligned}$$

Phase 6:

$$\begin{aligned}
 Y_{out}(336+n*4+1) = 1/128 * (& -12 * Y_{in}(372+n*3-1) \\
 & + 72 * Y_{in}(372+n*3) \\
 & + 76 * Y_{in}(372+n*3+1) \\
 & - 8 * Y_{in}(372+n*3+2))
 \end{aligned}$$

Phase 7:

$$\begin{aligned}
 Y_{out}(336+n*4+2) = 1/128 * (& -8 * Y_{in}(372+n*3) \\
 & + 76 * Y_{in}(372+n*3+1) \\
 & + 72 * Y_{in}(372+n*3+2) \\
 & - 12 * Y_{in}(372+n*3+3))
 \end{aligned}$$

Phase 8:

$$\begin{aligned}
 Y_{out}(336+n*4+3) = 1/128 * (& 15 * Y_{in}(372+n*3+1) \\
 & + 72 * Y_{in}(372+n*3+2) \\
 & + 49 * Y_{in}(372+n*3+3) \\
 & - 8 * Y_{in}(372+n*3+4))
 \end{aligned}$$

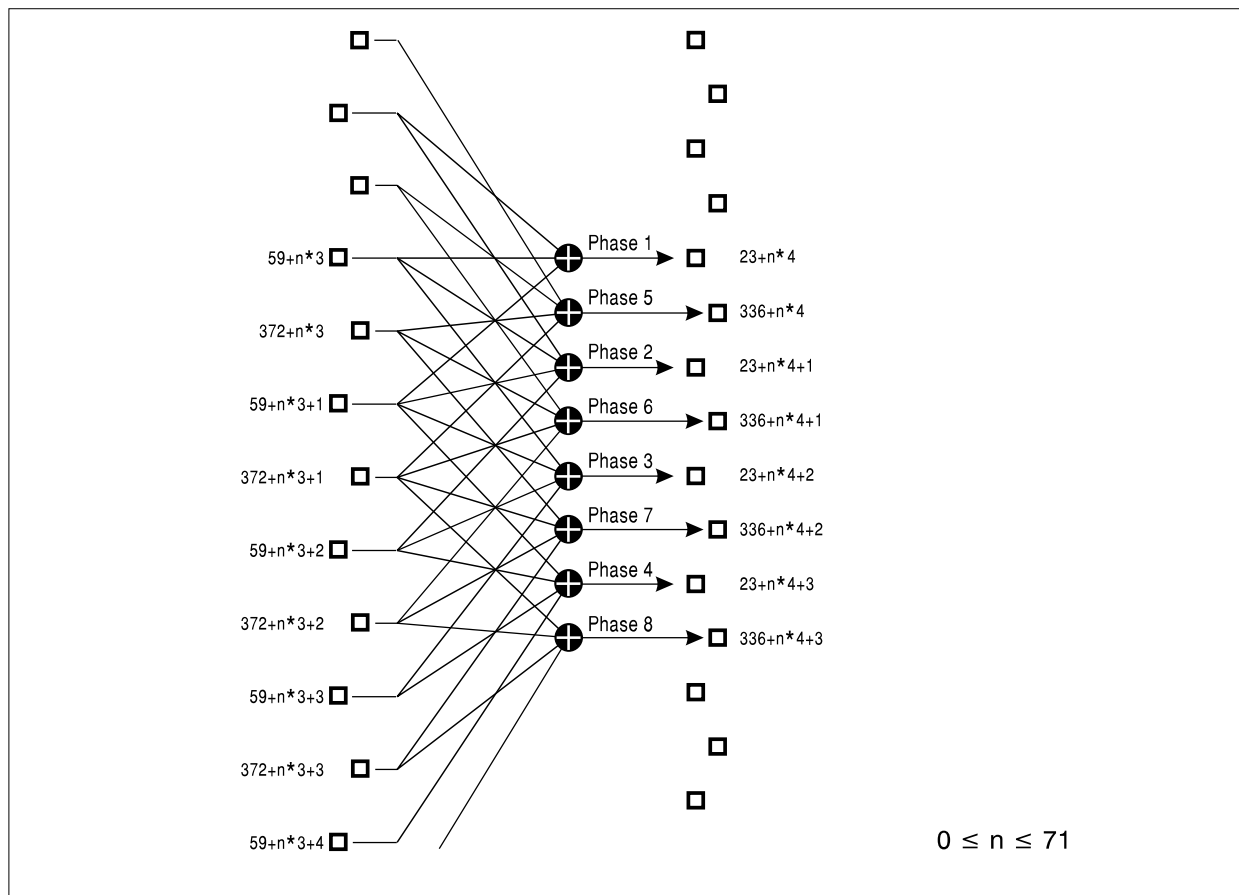

Figure D.1: DEC_UV_VSRC

D.2.4 DEC_UV_VSRC_NDL

(C_B/C_R 430 -> 576 line vertical sample rate conversion, if a PAL delay line has previously been included in the PAL decoding process)

Sampling grid in: field based, 215 lines

Sampling grid out: field based, 288 lines

41 taps, sum = 512, sum per phase = 64

<72> 69 62 51 37 24 10 1 -6 -9 -10 -9 -6 -3 0 1 2 2 2 1 1

The filter is applied as shown below:

$0 \leq n \leq 71$ (valid input lines: 60 to 274 and 372 to 586)

Phase 1:

$$Y_{out}(23+n*4) = 1/64 * (2 * Y_{in}(59+n*3-2) - 6 * Y_{in}(59+n*3-1) + 72 * Y_{in}(59+n*3) - 6 * Y_{in}(59+n*3+1) + 2 * Y_{in}(59+n*3+2))$$

Phase 2:

$$Y_{out}(23+n*4+1) = 1/64 * (10 * Y_{in}(59+n*3) \\ + 62 * Y_{in}(59+n*3+1) \\ - 10 * Y_{in}(59+n*3+2) \\ + 2 * Y_{in}(59+n*3+3))$$

Phase 3:

$$Y_{out}(23+n*4+2) = 1/64 * (1 * Y_{in}(59+n*3-1) \\ - 6 * Y_{in}(59+n*3) \\ + 37 * Y_{in}(59+n*3+1) \\ + 37 * Y_{in}(59+n*3+2) \\ - 6 * Y_{in}(59+n*3+3) \\ + 1 * Y_{in}(59+n*3+4))$$

Phase 4:

$$Y_{out}(23+n*4+3) = 1/64 * (2 * Y_{in}(59+n*3) \\ - 10 * Y_{in}(59+n*3+1) \\ + 62 * Y_{in}(59+n*3+2) \\ + 10 * Y_{in}(59+n*3+3))$$

Phase 5:

$$Y_{out}(336+n*4) = 1/64 * (1 * Y_{in}(372+n*3-2) \\ + 1 * Y_{in}(372+n*3-1) \\ + 69 * Y_{in}(372+n*3) \\ - 9 * Y_{in}(372+n*3+1) \\ + 2 * Y_{in}(372+n*3+2))$$

Phase 6:

$$Y_{out}(336+n*4+1) = 1/64 * (-3 * Y_{in}(372+n*3-1) \\ + 24 * Y_{in}(372+n*3) \\ + 51 * Y_{in}(372+n*3+1) \\ - 9 * Y_{in}(372+n*3+2) \\ + 1 * Y_{in}(372+n*3+3))$$

Phase 7:

$$Y_{out}(336+n*4+2) = 1/64 * (1 * Y_{in}(372+n*3-1) - 9 * Y_{in}(372+n*3) + 51 * Y_{in}(372+n*3+1) + 24 * Y_{in}(372+n*3+2) - 3 * Y_{in}(372+n*3+3))$$

Phase 8:

$$Y_{out}(336+n*4+3) = 1/64 * (2 * Y_{in}(372+n*3) - 9 * Y_{in}(372+n*3+1) + 69 * Y_{in}(372+n*3+2) + 1 * Y_{in}(372+n*3+3) + 1 * Y_{in}(372+n*3+4))$$

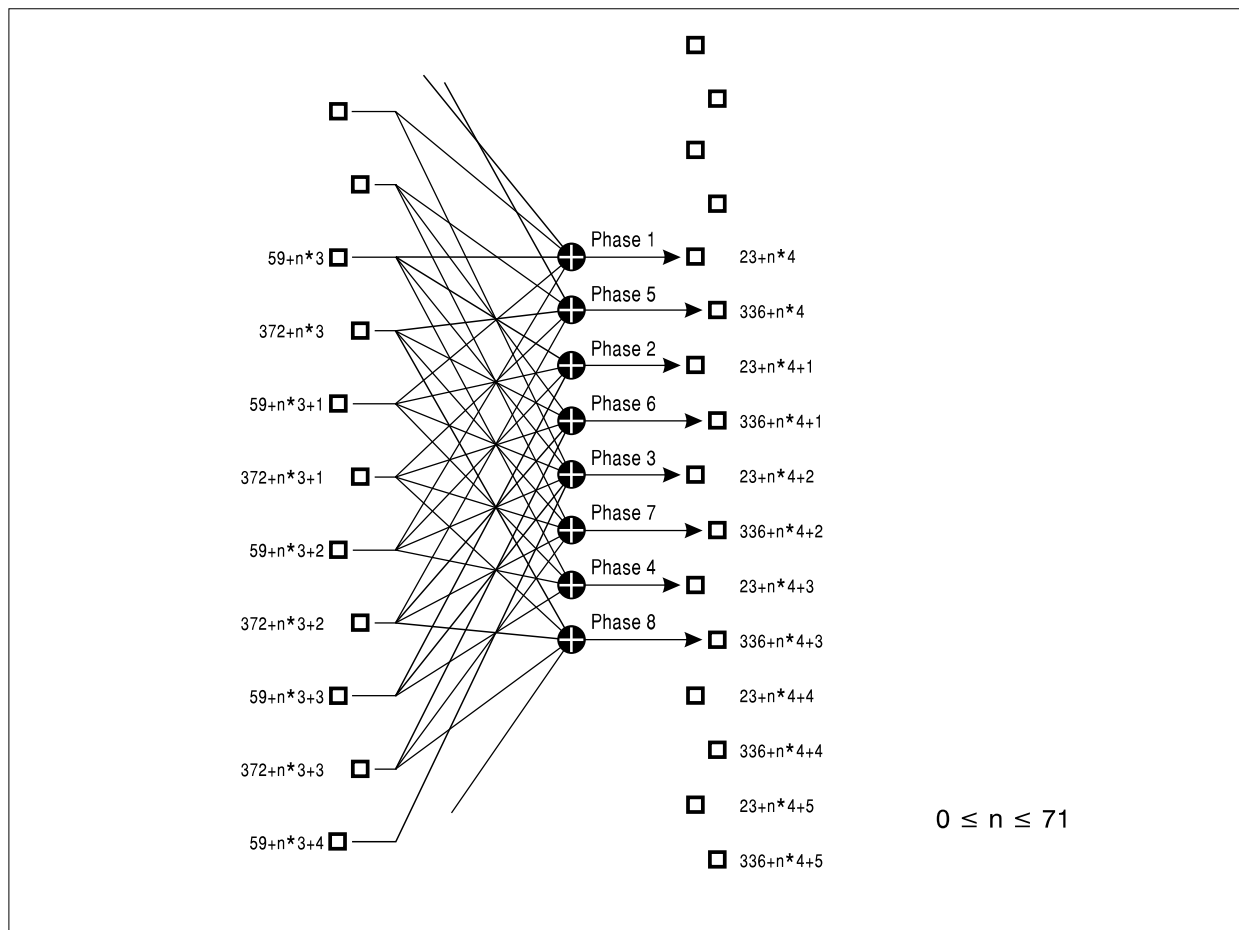

Figure D.2: DEC_UV_VSRC_NDL

D.3 Helper decoding

(See annex C, figure C.8)

D.3.1 DEC_BB_PRE_MOD

(Decoder black-band pre-demodulation low-pass filter)

System B/G: In practice, the required band-limiting should already have taken place at the IF stage, in which case filter DEC_BB_PRE_MOD need not be implemented.

If such filtering has not already taken place in the helper signal path, then the following filter would be required:

(in = out = 13,5 MHz)

25 taps, sum = 256

<218> 36 -31 24 -17 9 -3 -1 3 -3 3 -2 1

System I: Where a wider IF filter is used, or other circumstances where band-limiting of the vision signal to 5 MHz has not already taken place, the following filter is recommended to avoid impairment of the helper noise performance in comparison with that of System B/G:

(in = out = 13,5 MHz)

29 taps, sum = 256

<187> 58 -39 16 2 -11 11 -5 -2 5 -4 2 1 -2 1

D.3.2 DEC_BB_POST_MOD_LPF_ISS

(Decoder black-band post-demodulation low-pass and inverse spectrum shaping filter)

(in = out = 13,5 MHz)

15 taps, sum = 256

<190> 104 -24 -38 4 5 -11 -7

D.3.3 LUT_BB_DEC (film mode)

(Helper Decoder ROM look-up table, de-companding)

input value y	+0	+1	+2	+3	+4	+5	+6	+7
0	99	99	100	100	101	101	101	102
8	102	102	103	103	103	104	104	104
6	105	105	105	106	106	106	107	107
24	107	108	108	108	109	109	109	109
32	110	110	110	110	111	111	111	112
40	112	112	112	113	113	113	113	114
48	114	114	114	114	115	115	115	115
56	116	116	116	116	116	117	117	117
64	117	117	118	118	118	118	118	119
72	119	119	119	119	119	120	120	120
80	120	120	120	121	121	121	121	121
88	121	122	122	122	122	122	122	122
96	123	123	123	123	123	123	128	128
104	128	128	128	128	128	128	128	128
112	128	128	128	128	128	128	128	128
120	128	128	128	128	128	128	128	128
128	128	128	128	128	128	128	128	128
136	128	128	128	128	128	128	128	128
144	128	128	128	128	128	128	128	128
152	128	128	128	133	133	133	133	133
160	133	134	134	134	134	134	134	134
168	135	135	135	135	135	135	136	136
176	136	136	136	136	137	137	137	137
184	137	137	138	138	138	138	138	139
192	139	139	139	139	140	140	140	140
200	140	141	141	141	141	142	142	142
208	142	142	143	143	143	143	144	144
216	144	144	145	145	145	146	146	146
224	146	147	147	147	147	148	148	148
232	149	149	149	150	150	150	151	151
240	151	152	152	152	153	153	153	154
248	154	154	155	155	155	156	156	157

See annex D, subclause D.3.4, for derivation of the above values.

D.3.4 LUT_BB_DEC (camera mode)

(Helper Decoder ROM look-up table, de-companding)

input value y	+0	+1	+2	+3	+4	+5	+6	+7
0	41	41	41	41	41	41	41	41
8	41	41	41	41	41	41	41	41
6	41	41	41	41	43	45	47	48
24	50	52	54	56	57	59	60	62
32	64	65	67	68	69	71	72	74
40	75	76	77	79	80	81	82	83
48	84	85	86	87	88	89	90	91
56	92	93	94	95	96	97	97	98
64	99	100	101	101	102	103	103	104
72	105	105	106	107	107	108	109	109
80	110	110	111	111	112	112	113	113
88	114	114	115	115	116	116	116	117
96	117	118	118	118	119	119	119	120
104	120	120	121	121	121	122	122	122
112	123	123	123	128	128	128	128	128
120	128	128	128	128	128	128	128	128
128	128	128	128	128	128	128	128	128
136	128	128	128	128	128	128	133	133
144	133	134	134	134	135	135	135	136
152	136	136	137	137	137	138	138	138
160	139	139	140	140	140	141	141	142
168	142	143	143	144	144	145	145	146
176	146	147	147	148	149	149	150	151
184	151	152	153	153	154	155	155	156
192	157	158	159	159	160	161	162	163
200	164	165	166	167	168	169	170	171
208	172	173	174	175	176	177	179	180
216	181	182	184	185	187	188	189	191
224	192	194	196	197	199	200	202	204
232	206	208	209	211	213	215	215	215
240	215	215	215	215	215	215	215	215
248	215	215	215	215	215	215	215	215

The above values are derived from the following scaleable formula:

$$y' = y / \text{AmplFactor}$$

$$\text{IF } y' \leq 0,12 * Y_{\text{range}} \text{ THEN } x' = 0$$

$$\text{IF } y' > 0,12 * Y_{\text{range}} \text{ THEN } x' = X_{\text{range}} \left((p4 + p3) * \left[\frac{y'}{Y_{\text{range}}} * (1 - p2) + p2 \right]^{p1} - p3 \right)$$

$$x = \text{MIN} [x', 0,80 * Y_{\text{range}}]$$

where:

- x is the absolute non-companded value and y is the absolute companded value;
- $p1 = 0,0010$; $p2 = 0,9977126$; $p3 = 0,07477$; $p4 = 0,79981$;
- $\text{AmplFactor} = 1$ (camera mode), $\text{AmplFactor} = 2$ (film mode);
- the ranges are indicated with X_{range} and Y_{range} (both are 109).

NOTE 1: The DC-shift (128_{10}) is not included in the above formula.

NOTE 2: The companding curve is symmetrical about zero, such that negative values for x and y are derived directly from the absolute values provided by the formula.

D.4 Motion Adaptive Colour Plus, decoder

(See annex C, figure C.3)

D.4.1 Y_BSPLIT

(Luminance band-splitting filter)

(in = out = 13,5 MHz)

17 taps, sum = 256

<114> 79 13 -21 -10 7 7 -2 -2

D.4.2 DEC_Y_VAA

(Decoder intra-frame averaged high-frequency luminance vertical anti-alias filter, see annex C, figure C.4)

Sampling grid in: field based

215 lines (PALplus) or 287 lines (non-PALplus MACP)

Sampling grid out: field based

215 lines (PALplus) or 287 lines (non-PALplus MACP)

6 taps, total sum = 16 (sum per phase = 8)

-1 2 7 7 2 -1

NOTE 1: This filter is even-symmetrical.

The filter is applied as shown below:

$0 \leq n \leq 214$ (PALplus 430-line letterbox picture)

$-36 \leq n \leq 250$ (non-PALplus MACP)

NOTE 2: $Y_{in}(60+n) = Y_{in}(372+n)$.

Phase 1:

$$Y_{out}(60+n) = 1/8 * (-1 * Y_{in}(60+n-1) + 7 * Y_{in}(60+n) + 2 * Y_{in}(60+n+1))$$

Phase 2:

$$Y_{out}(372+n) = 1/8 * (2 * Y_{in}(372+n-1) + 7 * Y_{in}(372+n) - 1 * Y_{in}(372+n+1))$$

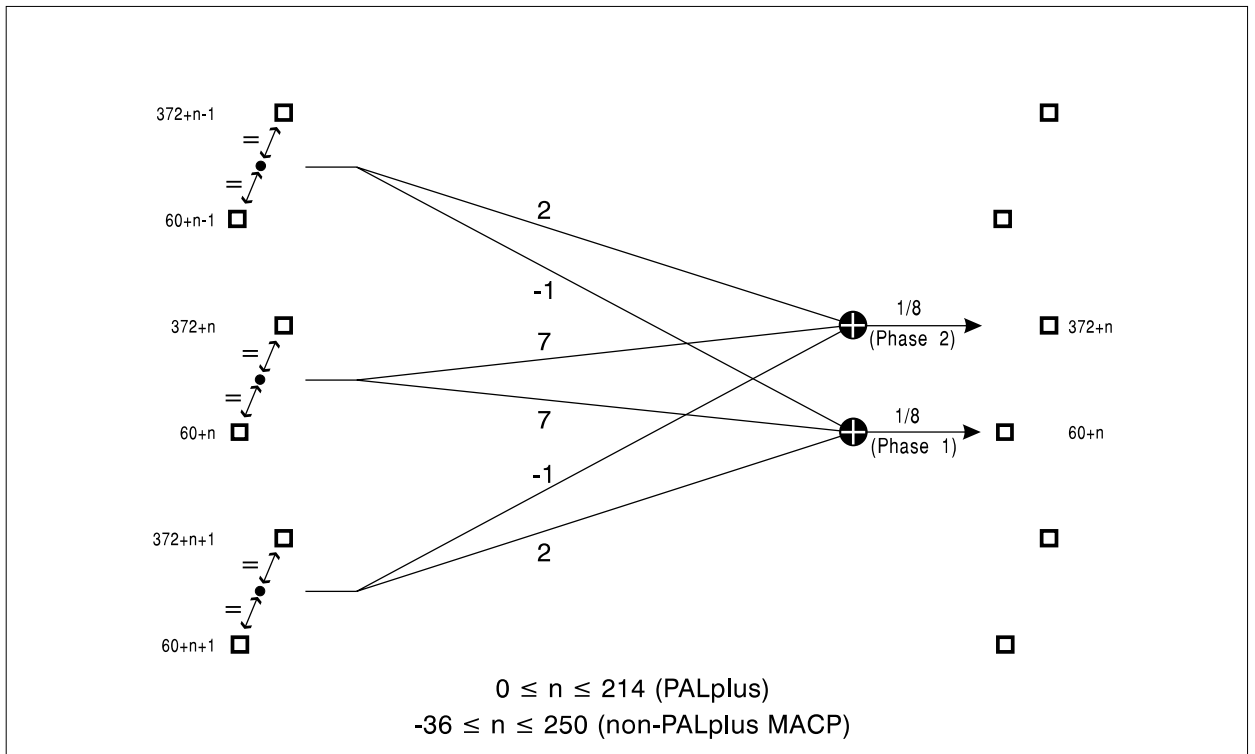

NOTE 1: This drawing illustrates the operation of the entire high-frequency luminance intra-frame averaging and vertical anti-aliasing processes shown in figure C.3.

NOTE 2: In the case of PALplus, 215 lines per field are processed; 287 lines per field are processed for non-PALplus MACP.

Figure D.3: DEC_Y_VAA

D.4.3 DEC_UV_LPF

(Colour-difference signal low-pass post-filters, see annex C, figure C.3)

The required filtering can be provided by the post-demodulation colour-difference signal down-sampling filters DEC_UV_DS_LPF (see annex C, figure C.2). DEC_UV_LPF is therefore not implemented. If the necessary low-pass filtering is not performed at an earlier stage, the following coefficients are suggested for DEC_UV_LPF:

(in = out = 6,75 MHz)

11 taps, sum = 256

<96> 74 26 -7 -11 -2

D.4.4 VERT_IFA

(Intra-frame averaging filter, see annex C, figures C.4 and C.5)

Sampling grid in: frame based
 430 lines (PALplus) or 574 lines (non-PALplus MACP)

Sampling grid out: field based
 215 lines (PALplus) or 287 lines (non-PALplus MACP)

2 taps, sum = 2

1 1

NOTE: This filter is even-symmetrical.

The filter is applied as shown below:

$0 \leq n \leq 214$ (PALplus 430-line letterbox picture)

$-36 \leq n \leq 250$ (non-PALplus MACP)

$$Y_{out}(60+n) = 1/2 * (Y_{in}(372+n) + Y_{in}(60+n))$$

$$Y_{out}(372+n) = Y_{out}(60+n)$$

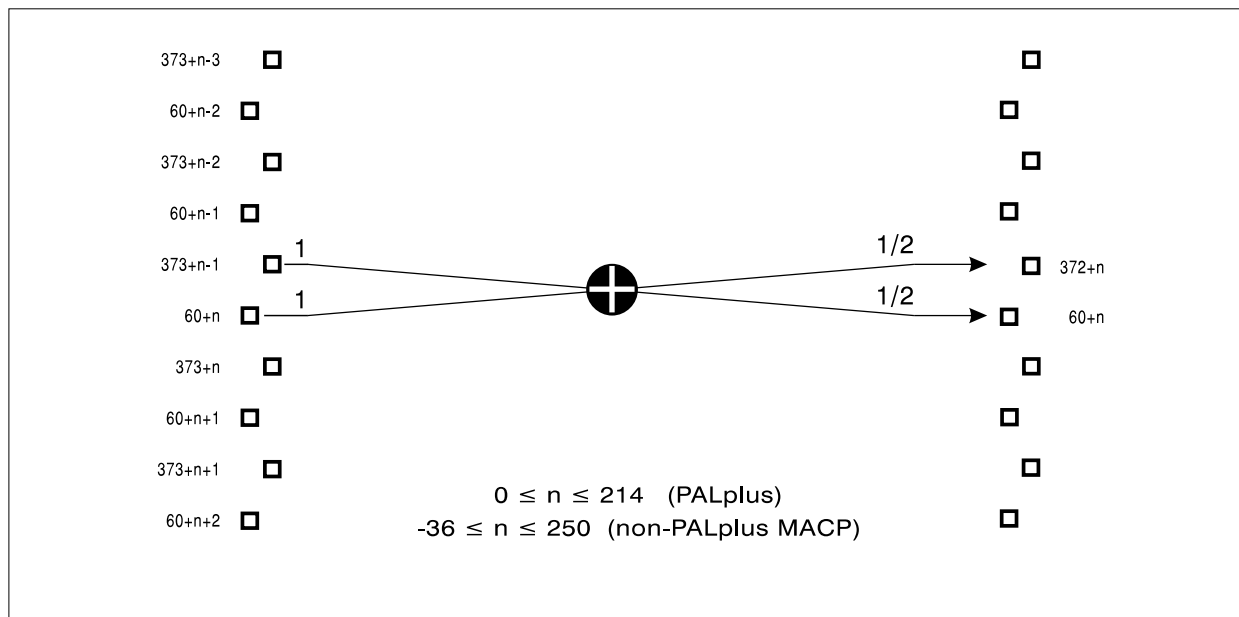

NOTE: This drawing illustrates the operation of the intra-frame averaging process, including the associated field delays shown in figures C.4 and C.5.

Figure D.4: VERT_IFA

D.4.5 DEC_MD_UV_LPF

(Decoder motion detector chain colour-difference signal filters, see annex C, figure C.6)

(in = out = 6,75 MHz)

5 taps, sum = 8

<2> 2 1

D.4.6 DEC_M_US

(Decoder motion detector chain motion signal up-sampling filter, see annex C, figure C.6)

(up-sample by 2: in = 6,75 MHz, out = 13,5 MHz)

3 taps, sum = 4, sum per phase = 2

<2> 1

D.4.7 LUT_IFD_U_CLIP

(Look-up table in motion detector chain: clipping of inter-frame difference of intra-frame averaged C_B signal $C_{B(IFAD)}$ to produce $C_{B(IFAd)}$)

input value $C_{B(IFAD)}$	+0	1	2	3	4	5	6	7	8	9	10	11	12	13	14	15
	output value $C_{B(IFAd)}$															
-256	31	31	31	31	31	31	31	31	31	31	31	31	31	31	31	31
-240	31	31	31	31	31	31	31	31	31	31	31	31	31	31	31	31
-224	31	31	31	31	31	31	31	31	31	31	31	31	31	31	31	31
-208	31	31	31	31	31	31	31	31	31	31	31	31	31	31	31	31
-192	31	31	31	31	31	31	31	31	31	31	31	31	31	31	31	31
-176	31	31	31	31	31	31	31	31	31	31	31	31	31	31	31	31
-160	31	31	31	31	31	31	31	31	31	31	31	31	31	31	31	31
-144	31	31	31	31	31	31	31	31	31	31	31	31	31	31	31	31
-128	31	31	31	31	31	31	31	31	31	31	31	31	31	31	31	31
-112	31	31	31	31	31	31	31	31	31	31	31	31	31	31	31	31
-96	31	31	31	31	31	31	31	31	31	31	31	31	31	31	31	31
-80	31	31	31	31	31	31	31	31	31	31	31	31	31	31	31	31
-64	31	31	31	31	31	31	31	31	31	31	31	31	31	31	31	31
-48	31	31	31	31	31	31	31	31	31	31	31	31	31	31	31	31
-32	31	31	30	29	28	27	26	25	24	23	22	21	20	19	18	17
-16	16	15	14	13	12	11	10	9	8	7	6	5	4	3	2	1
0	0	1	2	3	4	5	6	7	8	9	10	11	12	13	14	15
16	16	17	18	19	20	21	22	23	24	25	26	27	28	29	30	31
32	31	31	31	31	31	31	31	31	31	31	31	31	31	31	31	31
48	31	31	31	31	31	31	31	31	31	31	31	31	31	31	31	31
64	31	31	31	31	31	31	31	31	31	31	31	31	31	31	31	31
80	31	31	31	31	31	31	31	31	31	31	31	31	31	31	31	31
96	31	31	31	31	31	31	31	31	31	31	31	31	31	31	31	31
112	31	31	31	31	31	31	31	31	31	31	31	31	31	31	31	31
128	31	31	31	31	31	31	31	31	31	31	31	31	31	31	31	31
144	31	31	31	31	31	31	31	31	31	31	31	31	31	31	31	31
160	31	31	31	31	31	31	31	31	31	31	31	31	31	31	31	31
176	31	31	31	31	31	31	31	31	31	31	31	31	31	31	31	31
192	31	31	31	31	31	31	31	31	31	31	31	31	31	31	31	31
208	31	31	31	31	31	31	31	31	31	31	31	31	31	31	31	31
224	31	31	31	31	31	31	31	31	31	31	31	31	31	31	31	31
240	31	31	31	31	31	31	31	31	31	31	31	31	31	31	31	31

NOTE: This is identical to the encoder look-up table.

D.4.8 LUT_IFD_V_CLIP

(Look-up table in motion detector chain: clipping of inter-frame difference of intra-frame averaged C_R signal $C_{B(IFAD)}$ to produce $C_{B(IFAd)}$)

input value $C_{R(IFAD)}$	+0	1	2	3	4	5	6	7	8	9	10	11	12	13	14	15
	output value $C_{R(IFAd)}$															
-256	15	15	15	15	15	15	15	15	15	15	15	15	15	15	15	15
-240	15	15	15	15	15	15	15	15	15	15	15	15	15	15	15	15
-224	15	15	15	15	15	15	15	15	15	15	15	15	15	15	15	15
-208	15	15	15	15	15	15	15	15	15	15	15	15	15	15	15	15
-192	15	15	15	15	15	15	15	15	15	15	15	15	15	15	15	15
-176	15	15	15	15	15	15	15	15	15	15	15	15	15	15	15	15
-160	15	15	15	15	15	15	15	15	15	15	15	15	15	15	15	15
-144	15	15	15	15	15	15	15	15	15	15	15	15	15	15	15	15
-128	15	15	15	15	15	15	15	15	15	15	15	15	15	15	15	15
-112	15	15	15	15	15	15	15	15	15	15	15	15	15	15	15	15
-96	15	15	15	15	15	15	15	15	15	15	15	15	15	15	15	15
-80	15	15	15	15	15	15	15	15	15	15	15	15	15	15	15	15
-64	15	15	15	15	15	15	15	15	15	15	15	15	15	15	15	15
-48	15	15	15	15	15	15	15	15	15	15	15	15	15	15	15	15
-32	15	15	15	15	15	15	15	15	15	15	15	15	15	15	15	15
-16	15	15	14	13	12	11	10	9	8	7	6	5	4	3	2	1
0	0	1	2	3	4	5	6	7	8	9	10	11	12	13	14	15
16	15	15	15	15	15	15	15	15	15	15	15	15	15	15	15	15
32	15	15	15	15	15	15	15	15	15	15	15	15	15	15	15	15
48	15	15	15	15	15	15	15	15	15	15	15	15	15	15	15	15
64	15	15	15	15	15	15	15	15	15	15	15	15	15	15	15	15
80	15	15	15	15	15	15	15	15	15	15	15	15	15	15	15	15
96	15	15	15	15	15	15	15	15	15	15	15	15	15	15	15	15
112	15	15	15	15	15	15	15	15	15	15	15	15	15	15	15	15
128	15	15	15	15	15	15	15	15	15	15	15	15	15	15	15	15
144	15	15	15	15	15	15	15	15	15	15	15	15	15	15	15	15
160	15	15	15	15	15	15	15	15	15	15	15	15	15	15	15	15
176	15	15	15	15	15	15	15	15	15	15	15	15	15	15	15	15
192	15	15	15	15	15	15	15	15	15	15	15	15	15	15	15	15
208	15	15	15	15	15	15	15	15	15	15	15	15	15	15	15	15
224	15	15	15	15	15	15	15	15	15	15	15	15	15	15	15	15
240	15	15	15	15	15	15	15	15	15	15	15	15	15	15	15	15

NOTE: This is identical to the encoder look-up table.

D.4.9 LUT_MD_M

(Look-up table in motion detector chain: generation of chroma motion signal M)

input values	$C_{B(IFAd)}$															
	0	1	2	3	4	5	6	7	8	9	10	11	12	13	14	15
$C_{B(IFAd)}$	output value M															
0	0	1	2	3	4	5	6	7	8	9	10	11	12	13	14	15
1	1	1	2	3	4	5	6	7	8	9	10	11	12	13	14	15
2	1	2	2	3	4	5	6	7	8	9	10	11	12	13	14	15
3	2	2	3	4	5	6	7	8	9	10	11	12	13	14	15	15
4	3	3	3	4	5	6	7	8	9	10	11	12	13	14	15	15
5	3	4	4	4	5	6	7	8	9	10	11	12	13	14	15	15
6	4	4	5	5	5	6	7	8	9	10	11	12	13	14	15	15
7	5	5	5	6	6	7	8	9	10	11	12	13	14	15	15	15
8	6	6	6	6	7	7	8	9	10	11	12	13	14	15	15	15
9	6	7	7	7	7	8	8	9	10	11	12	13	14	15	15	15
10	7	7	8	8	8	8	9	9	10	11	12	13	14	15	15	15
11	8	8	8	9	9	9	9	10	10	11	12	13	14	15	15	15
12	8	9	9	9	10	10	10	10	11	12	13	14	15	15	15	15
13	9	9	10	10	10	11	11	11	11	12	13	14	15	15	15	15
14	10	10	10	11	11	11	12	12	12	12	13	14	15	15	15	15
15	10	11	11	11	12	12	12	13	13	13	13	14	15	15	15	15
16	11	11	12	12	12	13	13	13	14	14	14	14	15	15	15	15
17	12	12	12	13	13	13	14	14	14	14	15	15	15	15	15	15
18	12	13	13	13	14	14	14	15	15	15	15	15	15	15	15	15
19	13	13	14	14	14	15	15	15	15	15	15	15	15	15	15	15
20	14	14	14	15	15	15	15	15	15	15	15	15	15	15	15	15
21	14	15	15	15	15	15	15	15	15	15	15	15	15	15	15	15
22	15	15	15	15	15	15	15	15	15	15	15	15	15	15	15	15
23	15	15	15	15	15	15	15	15	15	15	15	15	15	15	15	15
24	15	15	15	15	15	15	15	15	15	15	15	15	15	15	15	15
25	15	15	15	15	15	15	15	15	15	15	15	15	15	15	15	15
26	15	15	15	15	15	15	15	15	15	15	15	15	15	15	15	15
27	15	15	15	15	15	15	15	15	15	15	15	15	15	15	15	15
28	15	15	15	15	15	15	15	15	15	15	15	15	15	15	15	15
29	15	15	15	15	15	15	15	15	15	15	15	15	15	15	15	15
30	15	15	15	15	15	15	15	15	15	15	15	15	15	15	15	15
31	15	15	15	15	15	15	15	15	15	15	15	15	15	15	15	15

NOTE: This is identical to the encoder look-up table.

D.4.10 LUT_DEC_MD_YL

(Look-up table in motion detector chain: generation of IFA high-frequency luminance level control signal L)

Input value M	0	1	2	3	4	5	6	7	8	9	10	11	12	13	14	15
Output value (4 * L)	4	4	4	4	4	4	4	4	4	4	3	2	1	0	0	0

D.4.11 LUT_DEC_MD_CS

(Look-up table in motion detector chain: generation of IFA chrominance switching control signal S)

Input value M	0	1	2	3	4	5	6	7	8	9	10	11	12	13	14	15
Output value (4 * S)	0	0	0	0	0	0	0	0	0	0	0	0	0	0	4	4

D.5 PAL decoding

(See annex C, figure C.2)

D.5.1 DEC_UV_DS_LPF

(Colour-difference signal post-demodulation down-sampling and low-pass filters)

(Down-sample by 2: in = 13,5 MHz; out = 6,75 MHz)

23 taps, sum = 512, divider = 256

<96> 90 74 50 26 6 -7 -12 -11 -7 -2 1

NOTE: A gain of two (at DC) is incorporated so as to ensure correct levels of the baseband U and V signals following chrominance demodulation and low-pass filtering.

D.5.2 DEC_CHROM_BPF

(Chrominance band-pass filter)

This filter should be sufficiently wide so as to have negligible effect on the low-pass filtering characteristic within the passband defined by filters DEC_UV_DS_LPF.

Typically 4,43 MHz ± 1,5 MHz ≥ -0,5 dB

Annex E (informative): Decoder filter plots

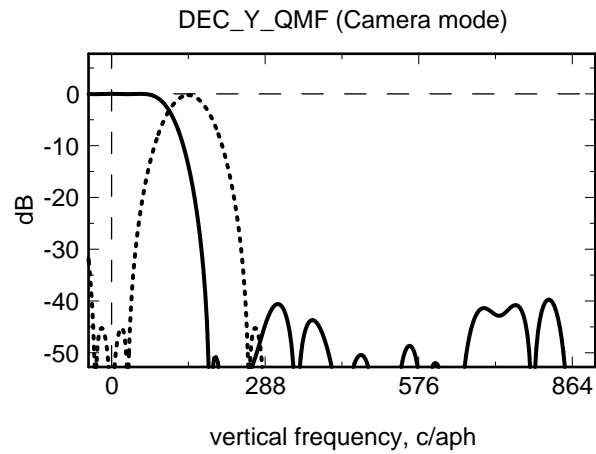

Figure E.1

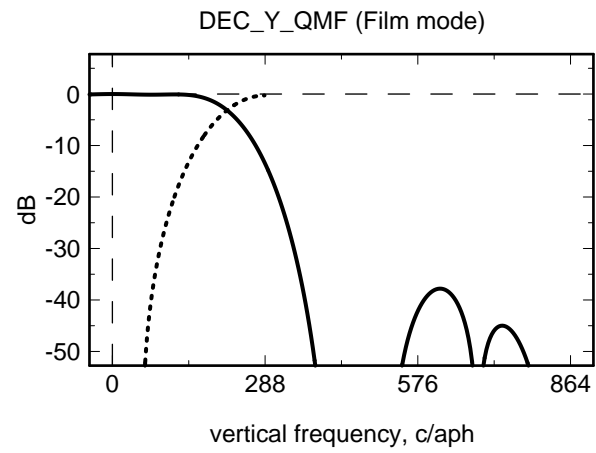

Figure E.2

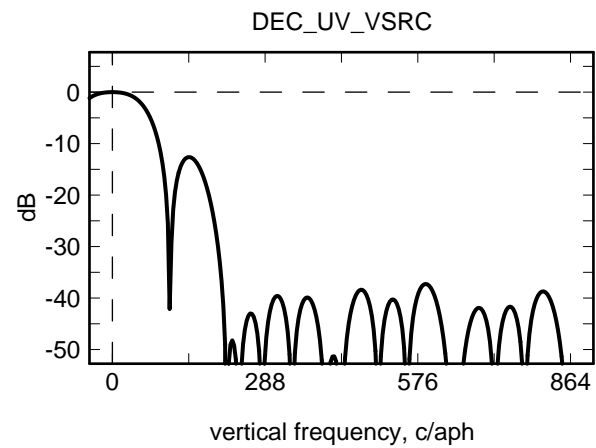

Figure E.3

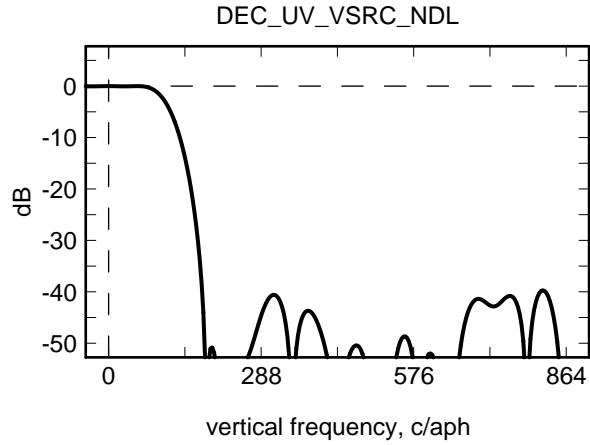
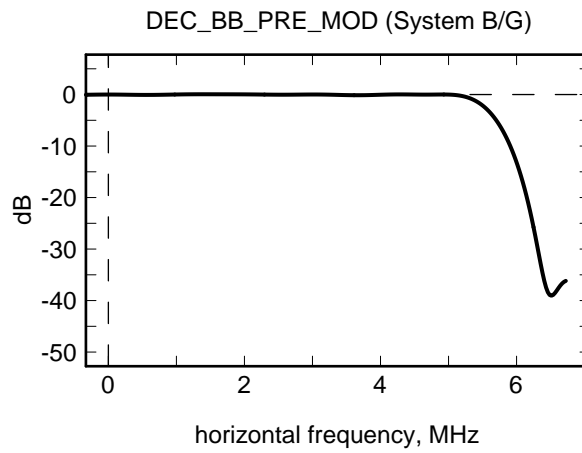

Figure E.4



NOTE: The required filtering would in practice be performed by the IF shaping, in which case filter DEC_BB_PRE_MOD need not be implemented for System B/G.

Figure E.5

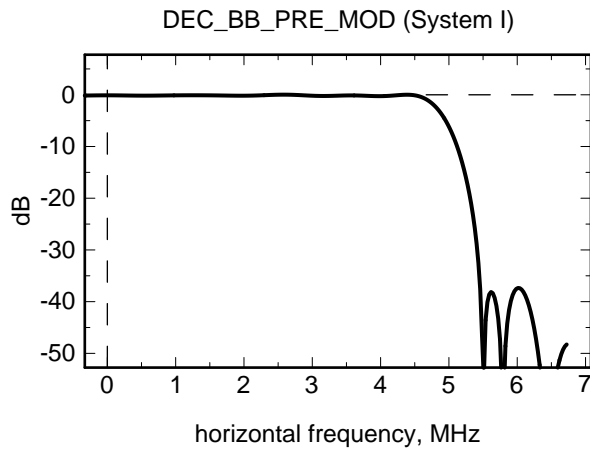

Figure E.6

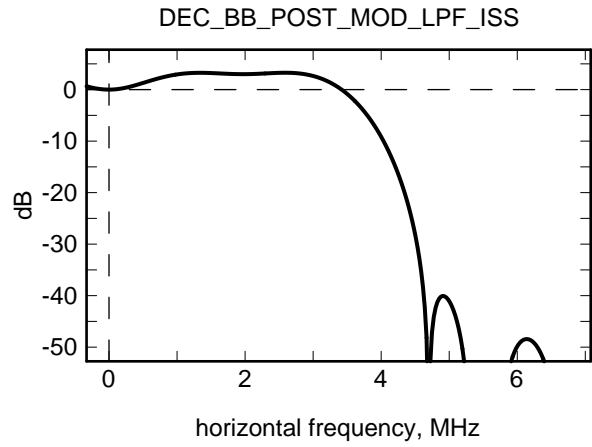

Figure E.7

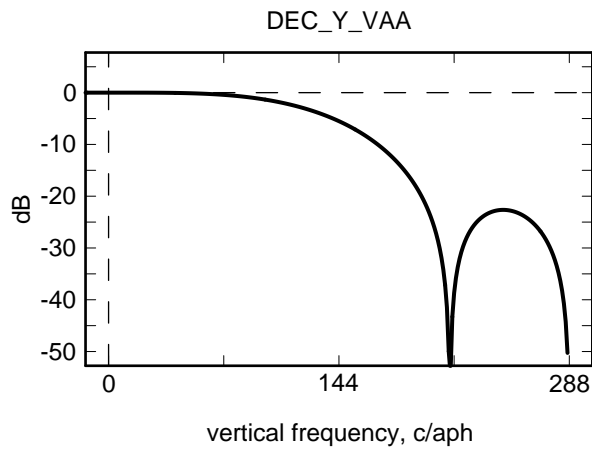

Figure E.8

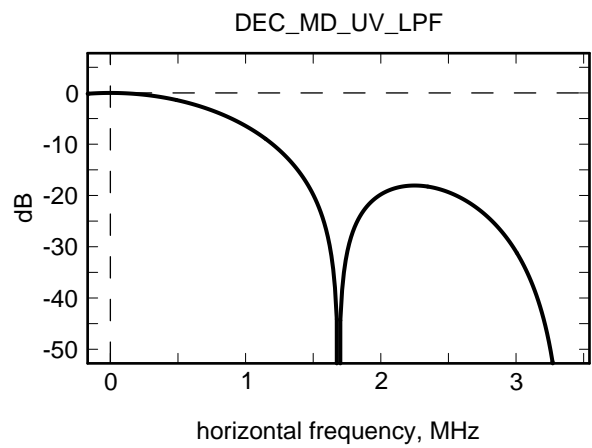

Figure E.9

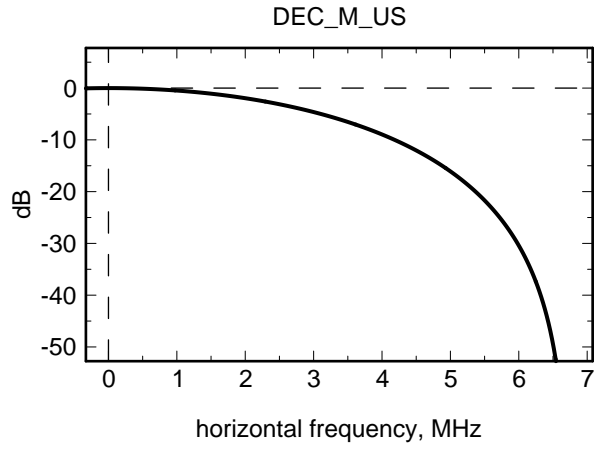

Figure E.10

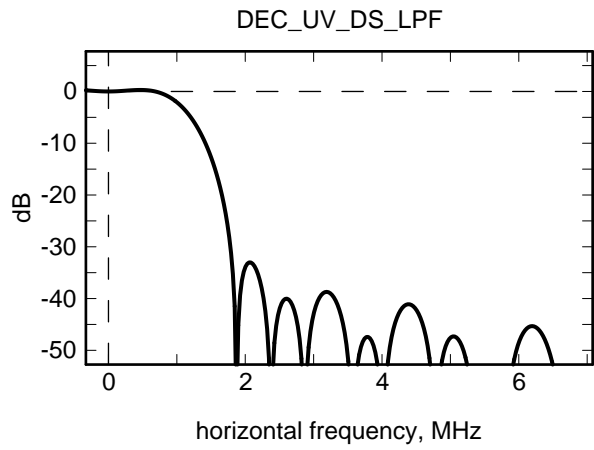

Figure E.11

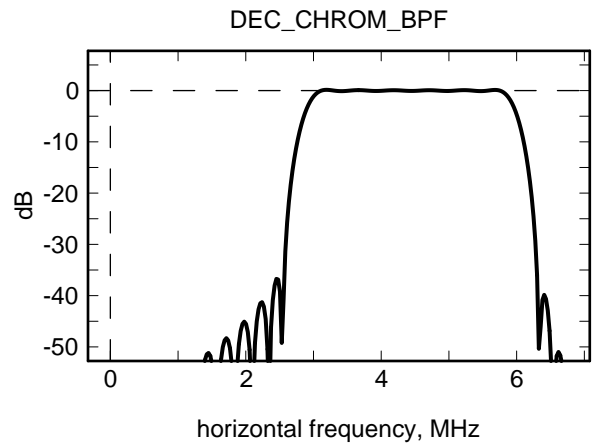

Figure E.12

Annex F (informative): Receivers for the PALplus system

F.1 General

The recovered luminance signal can be expected to have a horizontal bandwidth limited principally by the characteristics of the transmission system; for example, 5 MHz in the case of System B/G, or 5,5 MHz with System I.

The horizontal bandwidth of the decoded chrominance signals can be expected to be approximately 1,0 MHz (- 3 dB), depending on filtering chosen in the decoder, and the characteristics of the transmission system.

F.2 Receiver IF characteristics

Receivers should have a good, reasonably flat, IF vision response up to 4,43 MHz, and should exhibit no significant band-edge distortions up to 5,0 MHz in the case of Systems B/G and preferably up to 5,5 MHz for System I.

NOTE: In the case of System I, and where a wider IF bandwidth is used than for System B/G, additional filtering should preferably be applied to the modulated helper signal so as to avoid the introduction of noise above nominally 5 MHz (see DEC_BB_PRE_MOD in annex D, clause D.3 and filter plot in annex E).

F.3 Features included in a PALplus receiver

The standard method of display of a PALplus signal is in 625-line interlaced (50 Hz) form, with 576 active picture lines, but other upconverted display formats (for example, 50 Hz progressive or 100 Hz interlace) are optional.

Delays may be incorporated in the audio paths to compensate for the delay in the vision processing. The vision delay will depend on the receiver implementation, but might in practice be expected to be of the order of 30 ms.

The minimum features that should be included in a receiver to qualify for use of the PALplus Equipment Logo are summarised as follows:

- a wide-screen display device with an aspect ratio of 16:9;
- decoding of the Line 23 Wide Screen Signalling bits;
- vertical restoration of 576 picture lines by interpolation;
- use of the vertical helper signals in the case of camera mode.

Use of the vertical helper signals and Colour Plus decoding in the case of film mode, and Motion Adaptive Colour Plus decoding in camera mode, are recommended.

The various features that may be included in a PALplus receiver are summarised in table F.1.

Table F.1: The enhancement features incorporated in a PALplus receiver

Enhancement	Incorporated in a "PALplus" receiver?
16:9 aspect ratio display device	YES
Use of Wide Screen Signalling (ETS 300 294 [4])	YES
Format conversion from 430-line letterbox to 576 lines for display	YES
Use of vertical helper	Camera mode: YES Film mode: OPTIONAL
Motion Adaptive Colour Plus decoding	OPTIONAL
Use of Line 23/623 reference signals to assist with format conversion	OPTIONAL
Receiver display up-conversion (for example, 50 Hz progressive, or 100 Hz interlace)	OPTIONAL
Delays in audio paths to compensate for vision processing	OPTIONAL
Ghost cancellation	OPTIONAL

F.4 Receiver switching time in response to changes signalled by the WSS

When a change of status is signalled by the Line 23 WSS (according to ETS 300 294 [4]), the time taken for a receiver to respond is made up of two components: the "detection time" (the time taken for a receiver to determine that a change in WSS status has taken place) and the "mode switching time" (having detected that a change has taken place, this is the additional time taken to implement the change).

As a target, it is recommended that the time delay from the beginning of the frame in which an aspect ratio format change is signalled by the WSS, to the display of a stable picture in the newly signalled format (i.e., the total of the "detection time" and the "mode switching time") should not exceed 8 frames.

NOTE: This guideline applies only when responding to a change of aspect ratio signalled explicitly using the WSS. Additional margin for the "detection time" may be needed for reliable detection of a loss of WSS signalling.

It is advisable to avoid visible spurious picture disturbances during the period of aspect ratio switching (the "mode switching time") that might, for example, be caused by deflection changes.

F.5 Use of Wide Screen Signalling (WSS)

The following are examples of some of the signalling options.

F.5.1 PALplus

$b_0=1, b_1=1, b_2=0, b_3=1, b_4=\text{camera/film bit}, b_5=1, b_6=1$

NOTE 1: It is recommended that PALplus decoders should not prevent the use of PALplus processing in the case of transmissions having a ">16:9 letterbox centre" aspect ratio label. There would be no change to helper or MACP processing, this is simply an alternative signalling condition to permit PALplus processing in the receiver:

$b_0=1, b_1=0, b_2=1, b_3=1, b_4=\text{camera/film bit}, b_5=1, b_6=1$

NOTE 2: It is recommended that PALplus decoders should not make use of the helper signal for transmissions signalled as having "subtitles out of active image area":

$b_9=0, b_{10}=1.$

F.5.2 Non-PALplus Motion Adaptive Colour Plus

Motion Adaptive Colour Plus can be used with component picture sources having any of the eight possible combinations of aspect ratio and letterbox position defined by the three aspect ratio label bits (and associated parity bit) of the WSS, such that:

$b_0=x$, $b_1=x$, $b_2=x$, b_3 =odd parity bit, b_4 =camera/film bit, $b_5=1$, $b_6=0$

EXAMPLE: For studio or contribution/distribution applications, anamorphic 16:9 aspect ratio non-PALplus MACP may be used: $b_0=1$, $b_1=1$, $b_2=1$, $b_3=0$, b_4 =camera/film bit, $b_5=1$, $b_6=0$

F.5.3 Conventional PAL

Where WSS data is included, bits b_0 , b_1 , b_2 may be used to indicate various aspect ratios of a conventional PAL transmission, as defined in the WSS. Similarly, the Film bit b_4 may also be used by receivers to perform optimum upconversion, even with transmissions using standard PAL coding:

$b_0=x$, $b_1=x$, $b_2=x$, b_3 =odd parity bit, b_4 =camera/film bit, $b_5=0$, $b_6=0$

F.5.4 Conventional PAL with helper

The option exists to signal the presence of a helper with conventional PAL 16:9 centre letterbox:

$b_0=1$, $b_1=1$, $b_2=0$, $b_3=1$, b_4 =camera/film bit, $b_5=0$, $b_6=1$

EXAMPLE: This is the signal format replayed by a "type 1" PALplus video cassette recorder.

F.5.5 Transmissions transcoded into SECAM

There may be circumstances in which PAL/PALplus signals are transcoded directly into SECAM, with no attempt to alter the signalling information carried by the WSS. Therefore, in the case of receivers designed for operation in a SECAM environment, it is advisable to ensure that use of the PALplus helper signal is made only when a transmission is being received in the PAL system, regardless of the status of bit b_6 as signalled by the WSS.

Annex G (informative): Application of ghost cancellation

Correct operation of the Motion Adaptive Colour Plus process relies on the fact that points separated by 312 lines within a frame have a precise phase relationship.

In order to avoid disturbing this relationship, any changes to the equalisation of the signal applied by a ghost canceller located in either the transmission or reception chain should be made during the period of lines 624 to 22.

Annex H (informative): Studio production requirements

H.1 General

PALplus is an enhanced 16:9 aspect ratio letterbox transmission format, and is not designed as a format for programme production.

Programme material intended for PALplus transmission should be sourced and post-produced using component studio equipment operating in the full-height wide-screen aspect ratio of 16:9 (i.e. anamorphic, with nominal 576 active lines), and able to deliver a 4:2:2 625/50/2:1 16:9 aspect ratio digital component input signal (in accordance with ITU-R Recommendation BT.601-5 [1] part A) to the input of the PALplus encoder.

NOTE 1: Down-conversion to letterbox for transmission is an integral function performed within a PALplus encoder.

In the case of film, for a transmission to be referred to as "PALplus", the aspect ratio of the image area scanned should be no greater than 1,90:1. (This corresponds to the wider limit of the definition of "16:9" in ETS 300 294 [4].)

For film scanned to give an aspect ratio $> 1,90:1$, the PALplus encoding process should be used with the WSS aspect ratio label set to ">16:9 letterbox centre" instead of "16:9 letterbox centre". Such a transmission should be referred to as "coded in PALplus quality" rather than "PALplus".

NOTE 2: Film scanned to give an image area aspect ratio $>16:9$ ($>1,78:1$) should be input to a PALplus encoder as an anamorphic letterbox, i.e., should be treated as a 16:9 aspect ratio source (nominal 576 active lines) containing black bands. When viewed on 4:3 receivers, the join between the black bands within the 16:9 letterbox picture area and the black bands of the PALplus letterbox can be visible, unless care is taken to match the film black to the electronically generated true black of the PALplus black bands.

H.2 Limitations of the composite PALplus signal

A composite PALplus signal should not be cross-faded or wiped with a PAL signal (see annex H, clause H.4 for switching between PAL and PALplus signals).

It may be possible to cross-fade or wipe horizontally between two PALplus signals, provided identical Line 23 WSS information is maintained. The two signals should both be in film mode, or both in camera mode.

NOTE 1: The mixer used to perform such a cross-fade or wipe should be capable of handling the entire contents of Line 23 and the first half of Line 623, and should not perform clipping of low-frequency luminance signals below black-level.

No picture information should be added (either by superimposing or mixing) to the black bands of the composite PALplus signal. The black bands are occupied by the helper signal, so that addition of other picture information (such as subtitles or station identification logos) would result in the generation of visible artefacts on PALplus receivers.

Studio or distribution equipment used to convey the composite PALplus signal should be transparent to the whole of Line 23 and the first half of Line 623, and should not introduce clipping of low-frequency luminance signals below black-level.

NOTE 2: The PALplus helper signals carried in the black bands are modulated on the colour subcarrier with a maximum amplitude of 300 mV peak-to-peak (see figure 2). However, these helper signals are wider in bandwidth than standard PAL chrominance signals and, within the aforementioned permitted signal amplitude range, contain energy within the composite signal between approximately 1 MHz and 5 MHz (see figure 8).

A composite PALplus signal cannot be recorded correctly via the composite input of a component video tape recorder designed for standard PAL operation.

A PALplus signal can be recorded on a composite digital video tape recorder.

NOTE 3: For a correct recording to be made on a composite digital video tape recorder, any circuits that would otherwise introduce clipping of low-frequency luminance signals below black-level should be disabled.

A composite PALplus signal should not be passed through equipment that incorporates decode/encode functions, or which includes processes in the spatial or temporal domain, and which are optimized only for standard PAL.

Synchronizers and other studio or distribution equipment should retain the correct PAL eight-field sequence, and should not introduce horizontal or vertical picture shifts. Care should be taken to avoid the introduction of inter-field jitter, as this can lead to cross-luminance following MACP decoding.

Cascading of the PALplus encoding and decoding process is possible, but can result in some loss of quality.

PALplus signals can be distributed via 140 Mbit/s composite digital circuits designed for standard PAL operation.

Where it is required to distribute a composite PALplus signal via a 34 Mbit/s digital contribution/distribution circuit, or a 140 Mbit/s codec incorporating PAL decode/encode processes, particular attention should be given to the design of the codec interface in order to ensure effective transparency.

Scrambling systems used for transmission have been found to be generally compatible, but should be evaluated individually for their transparency and picture quality.

Picture quality monitoring of a PALplus signal should be carried out using a correctly decoded PALplus picture, and should not rely only on viewing the PALplus letterbox picture.

H.3 Camera mode and film mode

In the case of programme material to be transmitted in film mode, field 1 should be dominant at all times.

It is technically possible to switch between camera mode and film mode within a single programme encoded in PALplus. However, receivers cannot necessarily be expected to react sufficiently quickly to avoid visible picture disturbances, since the WSS "detection time" target of 8 frames (see annex F, clause F.4) applies to detection of any changes in WSS status, not just for detection of changes in aspect ratio. It is therefore preferable to avoid switching between camera mode and film mode within a programme.

If a programme contains a mixture of camera material and film material, or if field dominance of part of the film material is incorrect or is in doubt, then camera mode should be selected. If it is nevertheless wished to switch directly between camera mode and film mode, then it is desirable that the encoder should blank the helper signal for a period of 8 frames immediately following the first transmission of the changed WSS data.

In the case of rolling titles inserted electronically onto film-sourced material which is transmitted in film mode, the originating character generator should change the vertical position of each row of titles only at frame boundaries. Otherwise, visible artefacts may result, in which case camera mode should be used.

H.4 Programme junctions between transmissions in PALplus and PAL

It is advisable to use the Line 23 WSS to signal that a transmission is in standard 4:3 PAL, and not to rely on the fact that absence of the WSS, by default, indicates a transmission to be in standard 4:3 PAL. Otherwise, PALplus receivers are likely to take longer to detect the change of transmission format, and this could result in pictures being processed and displayed incorrectly (see annex F, clause F.4).

At a junction between a transmission in PALplus and a transmission in another format, it is advisable to transmit full-frame black in the newly signalled format for a period of 8 frames following the first transmission of the changed Line 23 WSS status. This period represents the nominal time expected for

receivers to detect that a change of WSS status has occurred, during which the receiver display mode will remain unchanged.

It is advisable to ensure that the transmission of a change of Wide Screen Signalling status is neither advanced nor delayed with respect to the related change in picture format.

H.5 Open subtitles and logos

To minimise the likelihood of loss of important picture information due to the effects of receiver overscan on wide-screen receivers, open subtitling or station identification logos should be placed within the following "safe" picture area, which excludes the top and bottom edges each representing nominally 5 % of the full height of the 16:9 aspect ratio picture:

- a) prior to PALplus encoding (the preferred method), on the 16:9 aspect ratio component source picture:

lines 35 - 294 and 348 - 607 (inclusive);

- b) on the PALplus letterbox picture:

lines 68 - 262 and 381 - 575 (inclusive).

NOTE 1: If inserted directly into the composite PALplus letterbox picture, subtitles or logos should not contain chrominance information.

NOTE 2: Insertion of subtitles or logos directly into the composite PALplus letterbox picture can give rise to visible artefacts on PALplus receivers.

In addition, it is advisable to avoid insertion of subtitles within the left-hand and right-hand edges each representing 10 % of the full width of the 16:9 aspect ratio picture.

H.6 Non-PALplus use of Motion Adaptive Colour Plus

For the handling, recording and distribution of non-PALplus MACP signals, and programme junctions between transmissions of non-PALplus MACP and other formats, the same general constraints apply as for signals encoded in PALplus; these are outlined in annex H, clauses H.2, H.3 and H.4.

NOTE: Unlike PALplus, non-PALplus MACP (which does not include the vertical helper signals of PALplus) does not contain low-frequency energy below black level.

In the case of non-PALplus Motion Adaptive Colour Plus encoding of component picture sources that have been cropped electronically to give a letterbox picture (for example, in an aspect ratio of 14:9) it is desirable that pairs of lines at the top of the letterbox picture, and also at the bottom of the letterbox picture, are partner lines for MACP intra-frame averaging.

The top line of the letterbox picture should therefore be taken from an even field, and the bottom line of the letterbox picture from an odd field.

History

Document history			
May 1996	Public Enquiry	PE 106:	1996-05-20 to 1996-09-13
November 1996	Vote	V 115	1996-11-25 to 1997-01-17

History

Document history			
May 1996	Public Enquiry	PE 106:	1996-05-20 to 1996-09-13
November 1996	Vote	V 115:	1996-11-25 to 1997-01-17