



EUROPEAN
TELECOMMUNICATION
STANDARD

FINAL DRAFT
pr **ETS 300 727**

November 1996

Source: ETSI TC-SMG

Reference: DE/SMG-020661

ICS: 33.020

Key words: Digital cellular telecommunications system, Global System for Mobile communications (GSM)



**Digital cellular telecommunications system;
Substitution and muting of lost frames for Enhanced
Full Rate (EFR) speech traffic channels
(GSM 06.61)**

ETSI

European Telecommunications Standards Institute

ETSI Secretariat

Postal address: F-06921 Sophia Antipolis CEDEX - FRANCE

Office address: 650 Route des Lucioles - Sophia Antipolis - Valbonne - FRANCE

X.400: c=fr, a=atlas, p=etsi, s=secretariat - **Internet:** secretariat@etsi.fr

Tel.: +33 4 92 94 42 00 - Fax: +33 4 93 65 47 16

Copyright Notification: No part may be reproduced except as authorized by written permission. The copyright and the foregoing restriction extend to reproduction in all media.

© European Telecommunications Standards Institute 1996. All rights reserved.

Contents

Foreword	5
1 Scope	7
2 Normative references	7
3 Definitions and abbreviations	7
3.1 Definitions	7
3.2 Abbreviations	7
4 General.....	8
5 Requirements	9
5.1 Error detection	9
5.2 Lost speech frames	9
5.3 First lost SID frame	9
5.4 Subsequent lost SID frames	9
6 Example solution	9
6.1 Example solution for substitution and muting of lost speech frames.....	9
6.2 Example solution for substitution and muting of lost SID frames	11
History.....	12

Blank page

Foreword

This final draft European Telecommunication Standard (ETS) has been produced by the Special Mobile Group (SMG) Technical Committee of the European Telecommunications Standards Institute (ETSI) and is now submitted for the Vote phase of the ETSI standards approval procedure.

This final draft ETS defines a frame substitution and muting procedure which is used by the Receive (RX) Discontinuous Transmission (DTX) handler when one or more lost speech or Silence Descriptor (SID) frames are received from the Radio Sub System (RSS) within the digital cellular telecommunications system.

This final draft ETS corresponds to GSM technical specification, GSM 06.61, version 5.1.1

Proposed transposition dates	
Date of latest announcement of this ETS (doa):	3 months after ETSI publication
Date of latest publication of new National Standard or endorsement of this ETS (dop/e):	6 months after doa
Date of withdrawal of any conflicting National Standard (dow):	6 months after doa

Blank page

1 Scope

This European Telecommunication Standard (ETS) defines a frame substitution and muting procedure which shall be used by the Receive (RX) Discontinuous Transmission (DTX) handler when one or more lost speech or Silence Descriptor (SID) frames are received from the Radio Sub System (RSS).

The requirements of this ETS are mandatory for implementation in all GSM Base Station Systems (BSS)s and Mobile Stations (MS)s capable of supporting the enhanced Full Rate speech traffic channel. It is not mandatory to follow the bit exact implementation outlined in this ETS and the corresponding C-source code.

2 Normative references

This ETS incorporates by dated and undated reference, provisions from other publications. These normative references are cited at the appropriate places in the text and the publications are listed hereafter. For dated references, subsequent amendments to or revisions of any of these publications apply to this ETS only when incorporated in it by amendment or revision. For undated references, the latest edition of the publication referred to applies.

- [1] GSM 05.03 (ETS 300 575): "Digital cellular telecommunication system (Phase 2); Channel coding".
- [2] GSM 06.60 (ETS 300 726): "Digital cellular telecommunications system; Enhanced Full Rate (EFR) speech transcoding".
- [3] GSM 06.81 (ETS 300 729): "Digital cellular telecommunications system; Discontinuous transmission (DTX) for Enhanced Full Rate (EFR) speech traffic channels".
- [4] GSM 08.60 (ETS 300 737): "Digital cellular telecommunication system (Phase 2+); Inband control of remote transcoders and rate adaptors for Enhanced Full Rate (EFR) and Full Rate traffic channels".

3 Definitions and abbreviations

3.1 Definitions

For the purposes of this ETS the following definition applies.

5-point median operation: Consists of sorting the 5 elements belonging to the set for which the median operation is to be performed in an ascending order according to their values, and selecting the third largest value of the sorted set as the median value.

Further definitions of terms used in this ETS can be found in GSM 06.60 (ETS 300 726) [2], GSM 06.81 (ETS 300 729) [3], GSM 05.03 (ETS 300 575)[1] and GSM 08.60 (ETS 300 737) [4].

3.2 Abbreviations

For the purposes of this ETS the following abbreviations apply.

BFI	Bad Frame Indication from Radio Sub System
BSI_Abis	Bad Sub-block Indication obtained from A-bis CRC checks
PrevBFI	Bad Frame Indication of Previous frame
RSS	Radio Sub System
RX	Receive
DTX	Discontinuous transmission
SID	Silence Descriptor frame
CRC	Cyclic Redundancy Check
CCU	Channel Coding Unit
median5	5-point median operation
TRAU	Transcoding Rate Adaptation Unit

4 General

The purpose of frame substitution is to conceal the effect of lost frames. The purpose of muting the output in the case of several lost frames is to indicate the breakdown of the channel to the user and to avoid generating possible annoying sounds as a result from frame substitution procedure.

The RSS indicates lost speech or SID frames by setting its Bad Frame Indication flag (BFI) based on its 3-bit and 8-bit CRCs and possibly other error detection mechanisms. The TRAU calculates from the CRCs inserted by the CCU in the TRAU frames one BSI_Abis flag for every sub-block of speech parameters. If either one or both of these flags is set, the speech decoder shall either perform frame substitution.

The example solution provided in paragraph 6 applies only for bad frame handling on a complete speech frame basis. However some parts could be modified for substitution of bad sub-blocks.

5 Requirements

5.1 Error detection

An error is detected and the BFI-flag is set-by the RSS according to the principle described in section 4.

5.2 Lost speech frames

Normal decoding of lost speech frames would result in very unpleasant noise effects. In order to improve the subjective quality, lost speech frames shall be substituted with either a repetition or an extrapolation of the previous good speech frame(s). This substitution is done so that it will gradually decrease the output level, resulting in silencing of the output. Subclause 6.1 gives an example solution.

5.3 First lost SID frame

A single lost SID frame shall be substituted by the last valid SID frame and the procedure for valid SID frames be applied as described in GSM 06.81 (ETS 300 729) [3].

5.4 Subsequent lost SID frames

For the second lost SID frame, a muting technique shall be used on the comfort noise that will gradually decrease the output level (-3 dB/frame), resulting in silencing of the output of the decoder.

For subsequent lost SID frames, the muting of the output shall be maintained. Subclause 6.2 gives an example solution.

6 Example solution

The C-code of the following example is embedded in the bit exact software of the enhanced full rate codec.

6.1 Example solution for substitution and muting of lost speech frames

This example solution for substitution and muting is based on a state machine with seven states (figure 1):

The system starts in state 0. Each time a bad frame is detected, the state counter is incremented by one and is saturated when it reaches 6. Each time a good speech frame is detected, the state counter is reset to zero, except when we are in state 6, where we set the state counter to 5. The state indicates the quality of the channel: the bigger the state counter, the worse the channel quality is. The control flow of the state machine can be described with the following C-code (**BFI** = bad frame indicator, **State** = state variable):

```

if( BFI != 0 )
    State = State + 1;
else if(State == 6)
    State = 5;
else
    State = 0;
if( State > 6 )
    State = 6;

```

In addition to this state machine, the **Bad Frame Flag** from the previous frame is checked (**PrevBFI**). The processing depends on the value of the **State**-variable. In states 0 and 5, the processing depends also on the two flags **BFI** and **PrevBFI**.

The procedure can be described as follows:

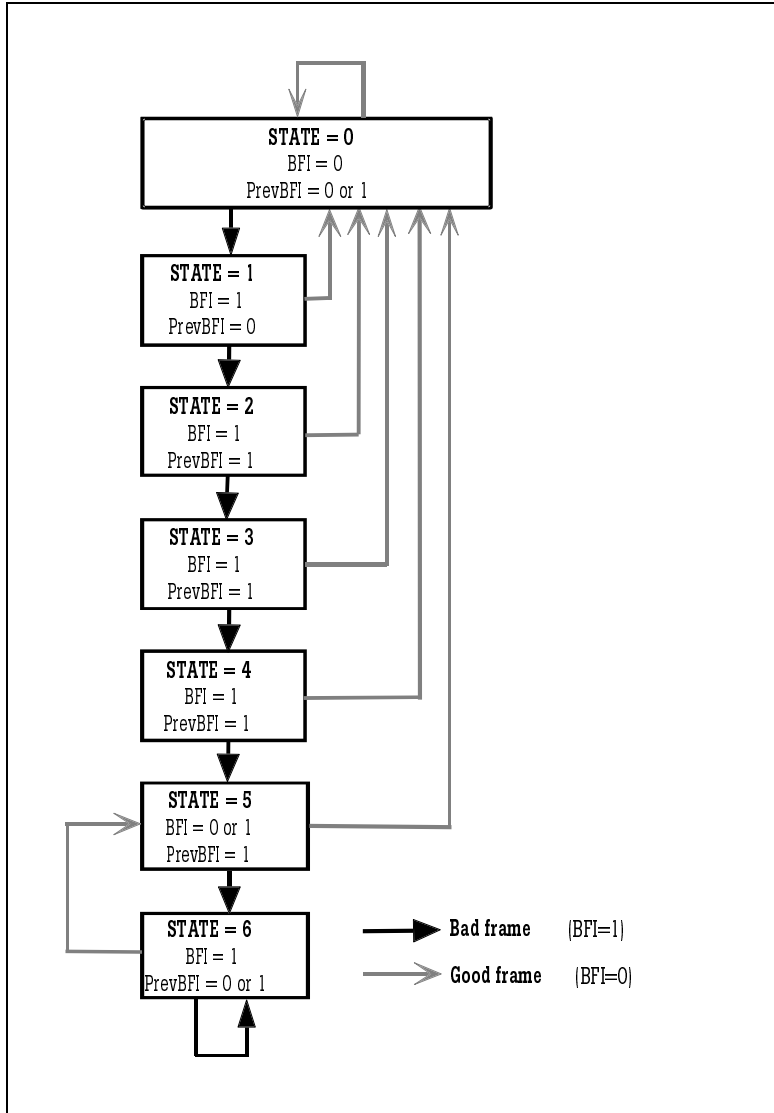

Figure 1: State machine for controlling the bad frame substitution

BFI = 0, PrevBFI = 0, State = 0

No error is detected in the received or in the previous received speech frame. The received speech parameters are used normally in the speech synthesis. The current frame of speech parameters is saved.

BFI = 0, PrevBFI = 1, State = 0 or 5

No error is detected in the received speech frame but the previous received speech frame was bad. The LTP-gain and fixed codebook gain are limited below the values used for the last received good subframe:

$$g^p = \begin{cases} g^p, & g^p \leq g^p(-1) \\ g^p(-1), & g^p > g^p(-1) \end{cases} \tag{1}$$

where g^p =current decoded LTP-gain, $g^p(-1)$ =LTP-gain used for the last good subframe (BFI=0), and

$$g^c = \begin{cases} g^c, & g^c \leq g^c(-1) \\ g^c(-1), & g^c > g^c(-1) \end{cases} \tag{2}$$

where g^c = current decoded fixed codebook-gain and $g^c(-1)$ = fixed codebook gain used for the last good subframe (BFI = 0).

The rest of the received speech parameters are used normally in the speech synthesis. The current frame of speech parameters is saved.

BFI = 1, PrevBFI = 0 or 1, State = 1...6

An error is detected in the received speech frame and the substitution and muting procedure is started. The LTP-gain and fixed codebook gain are replaced by attenuated values from the previous subframes:

$$g^p = \begin{cases} P(state) g^p(-1), & g^p(-1) \leq \text{median5}(g^p(-1), \dots, g^p(-5)) \\ P(state) \text{median5}(g^p(-1), \dots, g^p(-5)), & g^p(-1) > \text{median5}(g^p(-1), \dots, g^p(-5)) \end{cases} \quad (3)$$

where g^p = current decoded LTP-gain, $g^p(-1), \dots, g^p(-n)$ = LTP-gains used for the last n subframes, $\text{median5}()$ = 5-point median operation, $P(state)$ = attenuation factor ($P(1) = 0.98$, $P(2) = 0.98$, $P(3) = 0.8$, $P(4) = 0.3$, $P(5) = 0.2$, $P(6) = 0.2$), $state$ = state number, and

$$g^c = \begin{cases} C(state) g^c(-1), & g^c(-1) \leq \text{median5}(g^c(-1), \dots, g^c(-5)) \\ C(state) \text{median5}(g^c(-1), \dots, g^c(-5)), & g^c(-1) > \text{median5}(g^c(-1), \dots, g^c(-5)) \end{cases} \quad (4)$$

where g^c = current decoded fixed codebook gain, $g^c(-1), \dots, g^c(-n)$ = fixed codebook gains used for the last n subframes, $\text{median5}()$ = 5-point median operation, $C(state)$ = attenuation factor ($C(1) = 0.98$, $C(2) = 0.98$, $C(3) = 0.98$, $C(4) = 0.98$, $C(5) = 0.98$, $C(6) = 0.7$), and $state$ = state number.

The higher the state value is, the more the gains are attenuated. Also the memory of the predictive fixed codebook gain is updated by using the average value of the past four values in the memory:

$$\text{ener}(0) = \frac{1}{4} \sum_{i=1}^4 \text{ener}(-i) \quad (5)$$

The past LSFs are used by shifting their values towards their mean:

$$\text{lsf_q1}(i) = \text{lsf_q2}(i) = \alpha \text{past_lsf_q}(i) + (1 - \alpha) \text{mean_lsf}(i), \quad i = 0..9 \quad (6)$$

where $\alpha = 0.95$, lsf_q1 and lsf_q2 are two sets of LSF-vectors for current frame, past_lsf_q is lsf_q2 from the previous frame, and mean_lsf is the average LSF-vector.

The LTP-lag values are replaced by the past value from the 4th subframe of the previous frame.

The received fixed codebook excitation pulses from the erroneous frame are always used as such.

6.2 Example solution for substitution and muting of lost SID frames

The first lost SID frame is replaced by the last valid SID frame.

For subsequent lost SID frames, the last valid SID frame is repeated, but the fixed codebook gain is decreased with a constant value of -3 dB in each frame down to the minimum value of 0. This value is maintained if additional lost SID frames occur.

History

Document history			
March 1996	Public Enquiry	PE 103:	1996-03-04 to 1996-06-28
November 1996	Vote	V 115:	1996-11-25 to 1997-01-17