



**E**UROPEAN  
**T**ELECOMMUNICATION  
**S**TANDARD

**DRAFT**  
pr **ETS 300 720**

April 1996

---

Source: ETSI TC-RES

Reference: DE/RES-01011

ICS: 33.060.20 33.060.50

**Key words:** Maritime, radio

**Radio Equipment and Systems (RES);  
Technical characteristics and methods of measurement for UHF  
on-board communications systems and equipment**

**ETSI**

European Telecommunications Standards Institute

**ETSI Secretariat**

**Postal address:** F-06921 Sophia Antipolis CEDEX - FRANCE

**Office address:** 650 Route des Lucioles - Sophia Antipolis - Valbonne - FRANCE

**X.400:** c=fr, a=atlas, p=etsi,

Tel.: +33 92 94 42 00 - Fax: +33 93 65 47 16

\*

---

**Copyright Notification:** No part may be reproduced except as authorized by written permission. The copyright and the foregoing restriction extend to reproduction in all media.

© European Telecommunications Standards Institute 1996. All rights reserved.



## Contents

Foreword .....	7
1 Scope .....	9
2 Normative references .....	9
3 Definitions and abbreviations .....	9
3.1 Definitions .....	9
3.2 Abbreviations .....	9
4 General requirements .....	9
4.1 Construction .....	9
4.2 Frequencies .....	9
4.3 Controls .....	10
4.4 Switching time .....	10
4.5 Safety precautions .....	10
4.6 Class of emission and modulation characteristics .....	11
4.7 Battery .....	11
4.8 Loudspeaker and microphone .....	11
4.9 Labelling .....	11
4.10 Equipment documentation .....	11
5 Test conditions, power sources and ambient temperatures .....	11
5.1 Normal end extreme test conditions .....	11
5.2 Test power source .....	11
5.3 Normal test conditions .....	12
5.3.1 Normal temperature and humidity .....	12
5.3.2 Normal test voltage .....	12
5.4 Extreme test conditions .....	12
5.4.1 Extreme temperatures .....	12
5.4.1.1 Upper extreme temperature .....	12
5.4.1.2 Lower extreme temperature .....	12
5.4.2 Extreme test power supply values .....	12
5.4.2.1 Upper extreme test voltage .....	12
5.4.2.2 Lower extreme test voltage .....	12
5.5 Procedure for tests at extreme temperatures .....	12
6 General conditions of measurement .....	13
6.1 Test connections .....	13
6.2 Arrangements for test signals .....	13
6.2.1 Test signals applied to the transmitter input .....	13
6.2.2 Test signals applied to the antenna terminal .....	13
6.3 Receiver mute or squelch facility .....	13
6.4 Normal test modulation .....	14
6.5 Artificial antenna .....	14
6.6 Test channels .....	14
6.7 Measurement uncertainty and interpretation of the measuring results .....	14
6.7.1 Measurement uncertainty .....	14
6.7.2 Interpretation of the measurement results .....	14
7 Environmental tests .....	14
7.1 Procedure .....	14
7.2 Performance check .....	15
7.3 Drop test on hard surface .....	15
7.3.1 Definition .....	15
7.3.2 Method of measurement .....	15
7.3.3 Requirement .....	16

7.4	Temperature tests .....	16
7.4.1	General .....	16
7.4.2	Dry heat .....	16
7.4.2.1	Method of measurement .....	16
7.4.2.2	Requirement .....	16
7.4.3	Damp heat .....	16
7.4.3.1	Method of measurement .....	16
7.4.3.2	Requirement .....	16
8	Transmitter .....	17
8.1	Frequency error .....	17
8.1.1	Definition .....	17
8.1.2	Method of measurement .....	17
8.1.3	Limits .....	17
8.2	Carrier power .....	17
8.2.1	Definition .....	17
8.2.2	Method of measurement .....	17
8.2.3	Limit .....	17
8.3	Frequency deviation .....	17
8.3.1	Definition .....	17
8.3.2	Maximum frequency deviation .....	17
8.3.2.1	Method of measurement .....	17
8.3.2.2	Limit .....	18
8.3.3	Frequency deviation at modulation frequencies above 3 kHz .....	18
8.3.3.1	Method of measurement .....	18
8.3.3.2	Limits .....	18
8.4	Limitation characteristics of the modulator .....	18
8.4.1	Definition .....	18
8.4.2	Method of measurement .....	18
8.4.3	Limit .....	19
8.5	Sensitivity of the modulator, including microphone .....	19
8.5.1	Definition .....	19
8.5.2	Method of measurement .....	19
8.5.3	Limit .....	19
8.6	Audio frequency response .....	19
8.6.1	Definition .....	19
8.6.2	Method of measurement .....	19
8.6.3	Limit .....	19
8.7	Audio frequency harmonic distortion of the emission .....	20
8.7.1	Definition .....	20
8.7.2	Method of measurement .....	20
8.7.3	Limit .....	21
8.8	Adjacent channel power .....	21
8.8.1	Definition .....	21
8.8.2	Method of measurement .....	21
8.8.3	Limit .....	21
8.9	Residual modulation of the transmitter .....	21
8.9.1	Definition .....	21
8.9.2	Method of measurement .....	21
8.9.3	Limit .....	21
8.10	Transient frequency behaviour of the transmitter .....	22
8.10.1	Definition .....	22
8.10.2	Method of measurement .....	22
8.10.3	Limits .....	23
8.11	Conducted spurious emissions conveyed to the antenna .....	25
8.11.1	Definition .....	25
8.11.2	Method of measurement .....	25
8.11.3	Limit .....	25
9	Receiver .....	25
9.1	Harmonic distortion and rated audio frequency output power .....	25
9.1.1	Definition .....	25
9.1.2	Methods of measurement .....	25

9.1.3	Limits .....	26
9.2	Audio frequency response .....	26
9.2.1	Definition .....	26
9.2.2	Method of measurement .....	26
9.2.3	Limits .....	26
9.3	Maximum usable sensitivity .....	27
9.3.1	Definition .....	27
9.3.2	Method of measurement .....	27
9.3.3	Limits .....	28
9.4	Co-channel rejection .....	28
9.4.1	Definition .....	28
9.4.2	Method of measurement .....	28
9.4.3	Limit .....	28
9.5	Adjacent channel selectivity .....	28
9.5.1	Definition .....	28
9.5.2	Method of measurement .....	28
9.5.3	Limits .....	29
9.6	Spurious response rejection .....	29
9.6.1	Definition .....	29
9.6.2	Method of measurement .....	29
9.6.3	Limit .....	29
9.7	Intermodulation response .....	29
9.7.1	Definition .....	29
9.7.2	Method of measurement .....	29
9.7.3	Limit .....	30
9.8	Conducted spurious emissions conveyed to the antenna .....	30
9.8.1	Definition .....	30
9.8.2	Method of measurement .....	30
9.8.3	Limit .....	30
Annex A (normative): Adjacent channel power measurement .....		31
A.1	Method of measurement .....	31
A.2	Power measuring receiver specification .....	31
A.2.1	IF filter .....	31
A.2.2	Attenuation indicator .....	33
A.2.3	RMS value indicator .....	33
A.2.4	Oscillator and amplifier .....	33
History .....		34

Blank page

## Foreword

This draft European Telecommunication Standard (ETS) has been produced by the Radio Equipment and Systems (RES) Technical Committee of the European Telecommunications Standards Institute (ETSI), and is now submitted for the Public Enquiry phase of the ETSI standards approval procedure.

<b>Proposed transposition dates</b>	
Date of latest announcement of this ETS (doa):	3 months after ETSI publication
Date of latest publication of new National Standard or endorsement of this ETS (dop/e):	6 months after doa
Date of withdrawal of any conflicting National Standard (dow):	6 months after doa

Blank page



## 1 Scope

This ETS states the minimum technical characteristics required for UHF radio equipment and systems operating on frequencies allocated to the maritime mobile services by the ITU Radio Regulations, Appendix 20. [1]

## 2 Normative references

This ETS incorporates by dated or undated reference provisions from other publications. These normative references are cited at the appropriate places in the text and the publications are listed hereafter. For dated references subsequent references to, or revisions of any of these publications apply to this ETS only when incorporated in it by amendment or revision. For undated references, the latest edition of the publication referred to applies.

- [1] ITU Radio Regulations, Appendix 20: "Characteristics of equipment used for on-board communication in the bands between 450 and 470 MHz".
- [2] ETR 028: "Radio Equipment and Systems (RES); Uncertainties in the measurement of mobile radio equipment characteristics".
- [3] ITU-T Recommendation P.53 (1988): "Psophometers (apparatus for the objective measurement of circuit noise)".
- [4] ISO/R 694: "Positioning of magnetic compasses in ships".

## 3 Definitions and abbreviations

### 3.1 Definitions

For the purposes of this ETS, the following definition apply:

**modulation index:** The ratio between the frequency deviation and the modulation frequency.

### 3.2 Abbreviations

For the purposes of this ETS, the following abbreviations apply:

emf	electro-motive force
ERP	effective radiated power
RF	radio frequency
SINAD	signal + noise + distortion / noise + distortion

## 4 General requirements

### 4.1 Construction

The mechanical and electrical construction and finish of the equipment shall conform in all respects to good engineering practice and the equipment shall be suitable for use on board ships.

The equipment's colour shall neither be orange nor yellow.

### 4.2 Frequencies

The equipment shall operate either on single-frequency or two-frequency simplex channels on those frequencies specified in Appendix 20 of the Radio Regulations [1].

**Table 1: Single frequency simplex channels**

<b>Channel designator</b>	<b>Frequency</b>
Channel A	467,525 MHz
Channel B	467,550 MHz
Channel C	467,575 MHz
Channel D	457,525 MHz
Channel E	457,550 MHz
Channel F	457,575 MHz

**Table 2: Two-frequency simplex channels for use with repeater only**

<b>Channel designator</b>	<b>Transmit frequency</b>	<b>Receive frequency</b>
Channel G	467,525 MHz	457,525 MHz
Channel H	467,550 MHz	457,550 MHz
Channel J	467,575 MHz	457,575 MHz

Independent selection of transmitting and receiving frequencies shall not be possible.

The equipment shall be fitted with at least one single-frequency simplex channel, the frequency of which shall be 457,525 MHz.

It shall not be possible to transmit during channel-switching operations.

#### **4.3 Controls**

The equipment shall have the following controls:

- a channel selector which shall indicate the designator of the channel to which the equipment is set;
- on/off switch for the equipment with visual indication that the equipment is switched on;
- a manual non-locking, push-to-talk switch to operate the transmitter;
- an audio-frequency power volume control.

The user shall not have access to any control which, if wrongly set, might impair the technical characteristics of the equipment.

#### **4.4 Switching time**

The channel switching arrangements shall be such that the time necessary to change over from using one of the channels to using any other channel does not exceed 5 seconds.

The time necessary to change over from transmission to reception and vice versa, shall not exceed 0,3 seconds.

#### **4.5 Safety precautions**

Provision shall be made for protecting equipment from the effects of excessive current or voltage. Means shall be incorporated to prevent reversal of polarity of the battery power supply.

Equipment with an antenna socket shall not be damaged by the effect of open-circuit or short-circuit of the antenna socket for a period of at least 5 minutes.

The manufacturer shall declare the compass safe distance according to ISO Recommendation 694 [4], Method B.

#### **4.6 Class of emission and modulation characteristics**

The equipment shall use phase modulation, G3E (frequency modulation with a pre-emphasis of 6 dB/octave).

The equipment shall be designed to operate with a channel spacing of 25 kHz.

#### **4.7 Battery**

The battery may be integrated in the equipment.

Primary and/or secondary batteries may be used.

Provisions shall be made for replacing the battery easily.

If the equipment is fitted with secondary batteries, a suitable battery charger shall be recommended by the manufacturer.

#### **4.8 Loudspeaker and microphone**

The equipment shall be provided with a microphone and a loudspeaker which may be combined.

In the transmit condition the output of the receiver shall be muted.

#### **4.9 Labelling**

All controls shall be clearly labelled. The labelling shall include:

- the name of the manufacturer and his trade mark;
- the type number and serial number of the equipment; and
- the compass safe distance.

#### **4.10 Equipment documentation**

For the purpose of conformance testing in accordance with this ETS, adequate technical and operational documentation shall be supplied with the equipment.

### **5 Test conditions, power sources and ambient temperatures**

#### **5.1 Normal and extreme test conditions**

Tests shall be made under normal test conditions and also, where stated, under extreme test conditions.

#### **5.2 Test power source**

Unless otherwise stated, the battery of the equipment shall be replaced by a test power source capable of producing normal and extreme test voltages as specified in subclauses 5.3.2 and 5.4.2.

The voltage of the power source shall be measured at the input terminal of the equipment.

During testing, the power source voltage shall be maintained within a tolerance of  $\pm 3\%$  relative to the voltage level at the beginning of each test.

### **5.3 Normal test conditions**

#### **5.3.1 Normal temperature and humidity**

The normal temperature and humidity conditions for tests shall be a combination of temperature and humidity within the following limits:

- temperature: + 15 °C to + 35 °C;
- relative humidity: 20 % to 75 %.

#### **5.3.2 Normal test voltage**

The normal test voltage shall be the nominal voltage of the battery as declared by the manufacturer.

### **5.4 Extreme test conditions**

#### **5.4.1 Extreme temperatures**

##### **5.4.1.1 Upper extreme temperature**

Tests at the upper extreme temperature shall be made at + 55 °C.

##### **5.4.1.2 Lower extreme temperature**

Tests at the lower extreme temperature shall be made at - 20 °C.

#### **5.4.2 Extreme test power supply values**

##### **5.4.2.1 Upper extreme test voltage**

The upper extreme test voltage shall be declared by the manufacturer and shall not be lower than the following:

- when using primary batteries, the voltage corresponding to the voltage that a fresh battery gives at the upper extreme temperature when loaded with a load equal to that of the equipment in the muted receive condition;
- when using secondary batteries, the voltage corresponding to the voltage that a fully charged battery gives at the upper extreme temperature when loaded with a load equal to that of the equipment in the muted receive condition.

##### **5.4.2.2 Lower extreme test voltage**

The lower extreme test voltage shall be declared by the manufacturer and shall not be higher than the following:

- when using primary batteries, 0,85 times the voltage that a fresh battery gives at the lower extreme temperature when loaded with a load equal to that of the equipment in the muted receive condition;
- when using secondary batteries, 0,85 times the voltage that a fully charged battery gives at the lower extreme temperature when loaded with a load equal to that of the equipment in the muted receive condition.

### **5.5 Procedure for tests at extreme temperatures**

The equipment shall be placed in the test chamber at normal temperature. The maximum rate of rising or reducing the temperature of the chamber shall be 1 °C/minute. The equipment shall be switched off during the temperature-stabilising periods.

Before conducting tests at extreme temperatures, the equipment in the test chamber shall have reached thermal equilibrium and be subjected to the extreme temperature for a period of 10 to 16 hours.

For tests at the lower extreme temperature, the equipment shall then be switched on to the standby or receive condition for one minute, after which the relevant tests shall be performed.

For tests at the higher extreme temperature, the equipment shall then be switched on in the high power transmit condition for half an hour, after which the relevant tests shall be performed.

The temperature of the chamber shall be maintained at the extreme temperatures for the whole duration of the performance tests.

At the end of the test, and with the equipment still in the chamber, the chamber shall be brought to room temperature in not less than one hour. The equipment shall then be exposed to normal room temperature and humidity for not less than three hours or until moisture has dispersed, whichever is the longer, before the next test is carried out. Alternatively, observing the same precautions, the equipment may be returned directly to the conditions required for the start of the next tests.

## **6 General conditions of measurement**

### **6.1 Test connections**

For the purpose of testing, suitable connections to the following test points shall be made available:

- the antenna terminal (for 50  $\Omega$  connection);
- the transmitter audio input(s);
- the receiver audio output(s);
- the push-to-talk switch;
- the battery terminals for test power source connections.

### **6.2 Arrangements for test signals**

#### **6.2.1 Test signals applied to the transmitter input**

For the purpose of tests, the transmitter internal microphone shall be disconnected and an audio frequency signal generator shall be applied to the transmitter audio input terminals.

#### **6.2.2 Test signals applied to the antenna terminal**

Test signal generators shall be connected to the antenna terminal in such a way that the impedance presented to the receiver input is 50  $\Omega$ , irrespective of whether one or more test signals are applied simultaneously.

The levels of the test signals shall be expressed in terms of the emf.

The effects of any intermodulation product and noise product in the test signal generators should be negligible.

The nominal frequency of the receiver is the carrier frequency of the selected channel.

### **6.3 Receiver mute or squelch facility**

Unless otherwise specified, the receiver squelch facility shall be made inoperative for the duration of the tests.

#### 6.4 Normal test modulation

For normal test modulation, the modulation frequency shall be 1 kHz and the frequency deviation shall be  $\pm 3$  kHz.

#### 6.5 Artificial antenna

When tests are conducted with an artificial antenna, this shall be a 50  $\Omega$  non-reactive, non-radiating load.

#### 6.6 Test channels

Tests shall be carried out at the highest and lowest channels within the frequency range of the equipment.

#### 6.7 Measurement uncertainty and interpretation of the measuring results

##### 6.7.1 Measurement uncertainty

**Table 3: Absolute measurement uncertainties: maximum values**

RF frequency	$\pm 1 \times 10^{-7}$
RF power	$\pm 0,75$ dB
Maximum frequency deviation:	
- within 300 Hz to 6 kHz of audio frequency:	$\pm 5$ %
- within 6 kHz to 25 kHz of audio frequency:	$\pm 3$ dB
Deviation limitation	$\pm 5$ %
Adjacent channel power	$\pm 5$ dB
Audio output power	$\pm 0,5$ dB
Amplitude characteristics of receiver limiter	$\pm 1,5$ dB
Sensitivity at 20 dB SINAD	$\pm 3$ dB
Two-signal measurement	$\pm 4$ dB
Three-signal measurement	$\pm 3$ dB
Radiated emission of transmitter	$\pm 6$ dB
Radiated emission of receiver	$\pm 6$ dB
Transmitter transient time	$\pm 20$ %
Transmitter transient frequency	$\pm 250$ Hz

For the test methods according to this ETS the uncertainty figures are valid to a confidence level of 95 % calculated according to the methods described in ETR 028 [2].

##### 6.7.2 Interpretation of the measurement results

The interpretation of the results recorded in a test report for the measurements described in this ETS shall be as follows:

- the measured value related to the corresponding limit will be used to decide whether an equipment meets the requirements of this ETS;
- the measurement uncertainty value for the measurement of each parameter shall be included in the test report;
- the recorded value of the measurement uncertainty shall be, for each measurement, equal to or lower than the figures in table 3.

## 7 Environmental tests

### 7.1 Procedure

Environmental tests shall be carried out before any other tests of the same equipment in respect to the other requirements of this ETS are performed. The tests shall be carried out in the order they appear in this ETS.

Unless otherwise stated, the equipment shall be connected to an electrical power source during the periods for which it is specified that electrical tests shall be carried out. These tests shall be performed using normal test voltage.

## 7.2 Performance check

For the purpose of this ETS, the term "performance check" shall be taken to mean:

- for the transmitter:
  - carrier frequency:
    - with the transmitter connected to an artificial antenna (subclause 6.5), the transmitter shall be keyed without modulation. The carrier frequency shall be within  $\pm 1,5$  kHz of the nominal carrier frequency;
  - output power:
    - with the transmitter connected to an artificial antenna (subclause 6.5), the transmitter shall be keyed without modulation. With the output power switch set at maximum, the output power shall be between 0,4 W and 4 W.
- for the receiver:
  - maximum usable sensitivity:
    - a test signal at the nominal frequency of the receiver modulated with normal test modulation (subclause 6.4) shall be applied to the receiver input. The level of the input signal shall be adjusted until the SINAD at the output of the receiver is 20 dB and the output power is at least the rated output power (subclause 9.1.3). The level of the input signal shall be less than +12 dB $\mu$ V.

## 7.3 Drop test on hard surface

### 7.3.1 Definition

The immunity against the effects of dropping is the ability of the equipment to maintain the specified mechanical and electrical performance after being subjected to a series of drops on a hard wooden test surface.

### 7.3.2 Method of measurement

The test shall consist of a series of 6 drops, one on each surface.

During the test the equipment shall be fitted with a suitable set of batteries and antenna but it shall be switched off. The test shall be carried out under normal temperature and humidity conditions.

The hard wooden test surface shall consist of a piece of solid hard wood with a minimum thickness of 15 cm and a mass of 30 kg or more.

The height of the lowest part of the equipment under test relative to the test surface at the moment of release shall be 1 m.

Equipment shall be subjected to this test when configured for use as in operational circumstances.

If the equipment is to be used with, for example, a separate microphone and/or loudspeaker, the test shall be carried out for those accessories separately.

Following the test, the equipment shall be subjected to a performance check.

### 7.3.3 Requirement

The requirement for the performance check shall be met.

## 7.4 Temperature tests

### 7.4.1 General

The maximum rate of raising or reducing the temperature of the chamber in which the equipment is being tested shall be 1 °C/minute.

### 7.4.2 Dry heat

#### 7.4.2.1 Method of measurement

The equipment shall be placed in a chamber of normal temperature. The temperature shall then be raised to and maintained at + 70 °C ( $\pm 3$  °C) for a period of at least 10 hours. After this period any climatic control device provided in the equipment may be switched on and the chamber cooled to 55 °C ( $\pm 3$  °C). The cooling of the chamber shall be completed within 30 minutes.

The equipment shall then be switched on and shall be kept working continuously for a period of two hours. The transmitter shall be keyed with a duty cycle of one minute transmission and four minutes reception. The equipment shall be subjected to a performance check during the two-hour period.

The temperature of the chamber shall be maintained at + 55 °C ( $\pm 3$  °C) during the two-hour period.

At the end of the test, and with the equipment still in the chamber, the chamber shall be brought to room temperature in not less than one hour. The equipment shall then be exposed to normal room temperature and humidity for not less than three hours before the next test is carried out.

#### 7.4.2.2 Requirement

The requirement for the performance check shall be met.

### 7.4.3 Damp heat

#### 7.4.3.1 Method of measurement

The equipment shall be placed in a chamber at normal room temperature and humidity which, steadily, over a period three hours ( $\pm 30$  minutes), shall be heated from room temperature to + 40 °C ( $\pm 3$  °C) and shall during this period be brought to a relative humidity of 93 % ( $\pm 2$  %) so that excessive condensation is avoided.

30 minutes later the equipment shall be switched on, and shall then be kept working continuously for a period of two hours. The transmitter shall be keyed with a duty cycle of one minute transmission and four minutes reception.

The equipment shall be subjected to a performance check during the two-hour period.

The temperature and relative humidity of the chamber shall be maintained at + 40 °C  $\pm 3$  °C and 93 %  $\pm 2$  % during the two-hour, 30 minute period.

At the end of the test, and with the equipment still in the chamber, the chamber shall be brought to room temperature in not less than one hour. The equipment shall then be exposed to normal room temperature and humidity for not less than three hours, or until moisture has dispersed, whichever is longer, before the next test is carried out.

#### 7.4.3.2 Requirement

The requirement for the performance check shall be met.



## **8 Transmitter**

### **8.1 Frequency error**

#### **8.1.1 Definition**

The frequency error is the difference between the measured carrier frequency and its nominal value.

#### **8.1.2 Method of measurement**

The carrier frequency shall be measured in the absence of modulation, with the transmitter connected to an artificial antenna (subclause 6.5). Measurements shall be made under normal test conditions (subclause 5.3) and under extreme test conditions (subclauses 5.4.1 and 5.4.2 applied simultaneously) using the test channels specified in subclause 6.6.

#### **8.1.3 Limits**

The frequency error shall not exceed 2,3 kHz.

### **8.2 Carrier power**

#### **8.2.1 Definition**

The carrier power is the mean power delivered to the artificial antenna during one radio frequency cycle in the absence of modulation.

#### **8.2.2 Method of measurement**

The transmitter shall be connected to an artificial antenna (subclause 6.5) and the power delivered to this artificial antenna shall be measured. The measurements shall be made under normal test conditions (subclause 5.3) and under extreme test conditions (subclauses 5.4.1 and 5.4.2 applied simultaneously), using the test channels specified in subclause 6.6.

If an output power switch is fitted it shall be placed in the maximum position.

#### **8.2.3 Limit**

The carrier power shall not exceed 4 W.

### **8.3 Frequency deviation**

#### **8.3.1 Definition**

The frequency deviation is the difference between the instantaneous frequency of the modulated radio frequency signal and the carrier frequency in the absence of modulation.

#### **8.3.2 Maximum frequency deviation**

##### **8.3.2.1 Method of measurement**

The frequency deviation shall be measured at the output with the transmitter connected to an artificial antenna (subclause 6.5), by means of a deviation meter capable of measuring the maximum deviation, including that due to any harmonics and intermodulation products which may be generated in the transmitter.

The modulation frequency shall be varied between 100 Hz and 3 kHz. The level of this test signal shall be 20 dB above the level which produces normal test modulation (subclause 6.4). This test shall be carried out with the output power switch set at both maximum and minimum.

**8.3.2.2 Limit**

The maximum frequency deviation shall not exceed  $\pm 5$  kHz.

**8.3.3 Frequency deviation at modulation frequencies above 3 kHz**

**8.3.3.1 Method of measurement**

The transmitter shall operate under normal test conditions (subclause 5.3) connected to a load as specified in subclause 6.5. The transmitter shall be modulated by the normal test modulation (subclause 6.4). With the input level of the modulation signal being kept constant, the modulation frequency shall be varied between 3 kHz and 25 kHz and the frequency deviation shall be measured.

**8.3.3.2 Limits**

For modulation frequencies between 3 kHz and 6 kHz the frequency deviation shall not exceed the frequency deviation with a modulation frequency of 3 kHz. For a modulation frequency of 6 kHz, the frequency deviation shall not exceed  $\pm 1,5$  kHz, as shown in figure 1.

For modulation frequencies between 6 kHz and 25 kHz, the frequency deviation shall not exceed that given by a linear response of frequency deviation (in dB) against modulation frequency, starting at the point where the modulation frequency is 6 kHz and the frequency deviation is  $\pm 1,5$  kHz and inclined at 14 dB per octave, with the frequency deviation diminishing as the modulation frequency increases, as shown in figure 1.

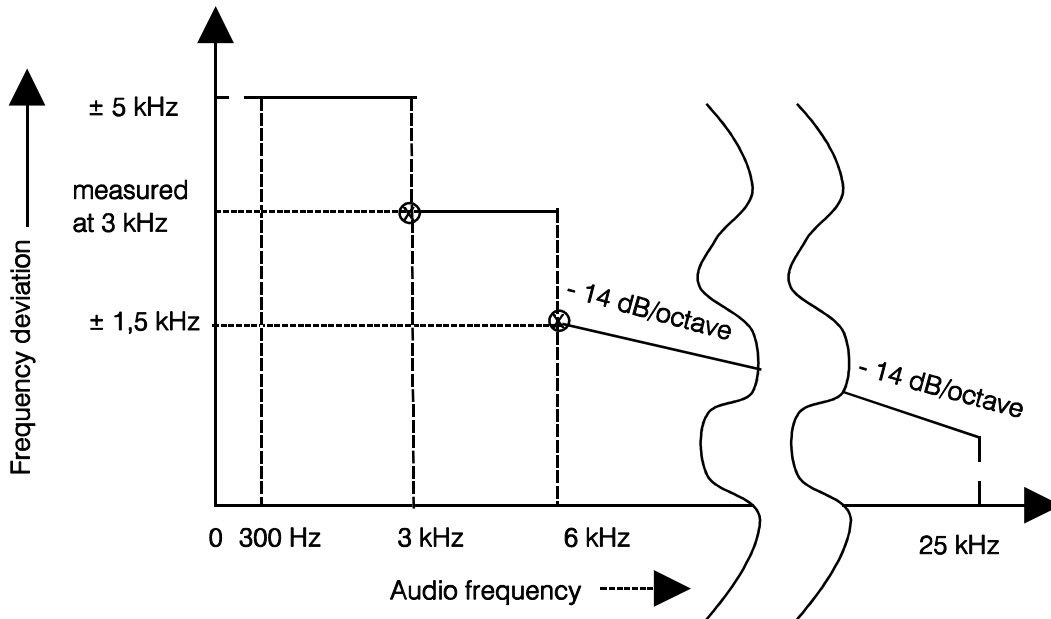

**Figure 1: Frequency deviation versus audio modulation frequency**

**8.4 Limitation characteristics of the modulator**

**8.4.1 Definition**

This characteristic expresses the capability of the transmitter of being modulated with a deviation approaching the maximum deviation specified in subclause 8.3.2.

**8.4.2 Method of measurement**

A modulation signal at a frequency of 1 kHz shall be applied to the transmitter, and its level adjusted so that the frequency deviation is  $\pm 1$  kHz. The level of the modulation signal shall then be increased by 20 dB and the deviation shall again be measured.

#### **8.4.3 Limit**

The frequency deviation shall be contained between  $\pm 3,5$  kHz and  $\pm 5$  kHz

### **8.5 Sensitivity of the modulator, including microphone**

#### **8.5.1 Definition**

This sensitivity expresses the capability of the transmitter to produce sufficient modulation when an audio frequency signal corresponding to the normal mean speech level is applied to the microphone.

#### **8.5.2 Method of measurement**

An acoustic signal with a frequency of 1 kHz and a sound level of 94 dBA relative to  $2 \times 10^{-5}$  Pa shall be applied to the microphone. The resulting frequency deviation shall be measured.

#### **8.5.3 Limit**

The resulting frequency deviation shall be between  $\pm 1,5$  kHz and  $\pm 3$  kHz.

### **8.6 Audio frequency response**

#### **8.6.1 Definition**

The audio frequency response expresses the ability of the transmitter to operate without excessive degradation of its frequency response as a function of the modulation frequency.

#### **8.6.2 Method of measurement**

A modulation signal at a frequency of 1 kHz shall be applied to the transmitter. Its level shall be adjusted so that the frequency deviation is  $\pm 1$  kHz.

The modulation frequency shall then be varied between 300 Hz and 3 kHz, with the level of the audio frequency signal being kept constant and equal to the value specified above.

#### **8.6.3 Limit**

The modulation index (ratio of the frequency deviation to the modulation frequency) shall be constant and equal to its value at 1 kHz, within the limits of + 1 dB and - 3 dB (figure 2).

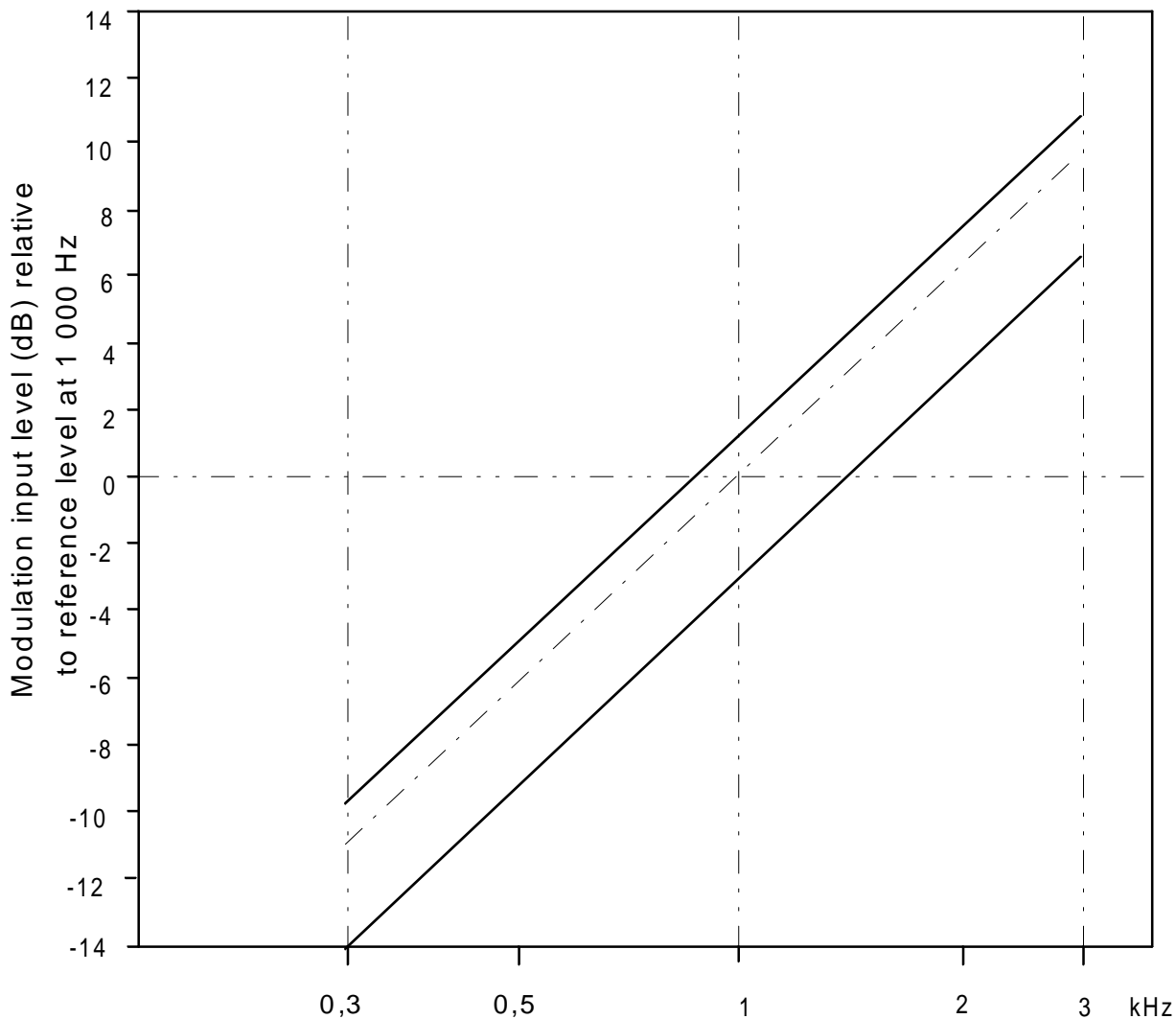

Figure 2: Audio frequency response

## 8.7 Audio frequency harmonic distortion of the emission

### 8.7.1 Definition

The harmonic distortion of the emission modulated by an audio frequency signal is defined as the ratio, expressed as a percentage, of the root mean square (rms) voltage of all the harmonic components of the fundamental frequency to the total rms voltage of the signal, measured after linear demodulation.

### 8.7.2 Method of measurement

The RF signal produced by the transmitter shall be applied via an appropriate coupling device to a linear demodulator with a de-emphasis network of 6 dB per octave.

The radio frequency signal shall be modulated successively at frequencies of 300 Hz and 1 000 Hz with a constant modulation index of 3.

The distortion of the audio frequency signal shall be measured at the frequencies specified above.

### **8.7.3 Limit**

The harmonic distortion shall not exceed 10 %.

## **8.8 Adjacent channel power**

### **8.8.1 Definition**

The adjacent channel power is that part of the total power output of a transmitter under defined conditions of modulation, which falls within a specified passband centered on the nominal frequency of either of the adjacent channels. This power is the sum of the mean power produced by the modulation, hum and noise of the transmitter.

### **8.8.2 Method of measurement**

The output of the transmitter shall be linked to the input of a measuring device such that the impedance presented to the transmitter is 50  $\Omega$ .

If an output power switch is fitted it shall be placed in the maximum position.

The transmitter shall be modulated with 1 250 Hz at a level which is 20 dB higher than that required to produce  $\pm 3$  kHz deviation.

The measurement shall be made in both adjacent channels.

A method of measurement using a power measuring receiver is described in annex A.

### **8.8.3 Limit**

The adjacent channel power shall not exceed a value of 70 dB below the carrier power of the transmitter without any need to be below 0,2  $\mu$ W.

## **8.9 Residual modulation of the transmitter**

### **8.9.1 Definition**

The residual modulation of the transmitter is the ratio, in dB, of the demodulated RF signal in the absence of wanted modulation, to the demodulated RF signal produced when the normal test modulation is applied.

### **8.9.2 Method of measurement**

The normal test modulation defined in subclause 5.3 shall be applied to the transmitter. The high frequency signal produced by the transmitter shall be applied, via an appropriate coupling device, to a linear demodulator with a de-emphasis network of 6 dB per octave. The time constant of this de-emphasis network shall be at least 750  $\mu$ s.

Precautions shall be taken to avoid the effects of emphasizing the low audio frequencies produced by internal noise.

The signal shall be measured at the demodulator output using an rms voltmeter.

The modulation shall then be switched off and the level of the residual audio frequency signal at the output shall be measured again.

### **8.9.3 Limit**

The residual modulation shall not exceed - 40 dB.

## 8.10 Transient frequency behaviour of the transmitter

### 8.10.1 Definition

The transient frequency behavior of the transmitter is the variation in time of the transmitter frequency difference from the nominal frequency of the transmitter when the RF output power is switched on and off.

- $t_{on}$ : according to the method of measurement described in subclause 8.10.2 the switch-on instant  $t_{on}$  of a transmitter is defined by the condition when the output power, measured at the antenna port, exceeds 0,1 % of the nominal power;
- $t_1$ : period of time starting at  $t_{on}$  and finishing according to table 4;
- $t_2$ : period of time starting at the end of  $t_1$  and finishing according to table 4;
- $t_{off}$ : switch-off instant defined by the condition when the nominal power falls below 0,1 % of the nominal power;
- $t_3$ : period of time that finishing at  $t_{off}$  and starting according to table 4.

**Table 4**

$t_1$ (ms)	5,0
$t_2$ (ms)	20,0
$t_3$ (ms)	5,0

### 8.10.2 Method of measurement

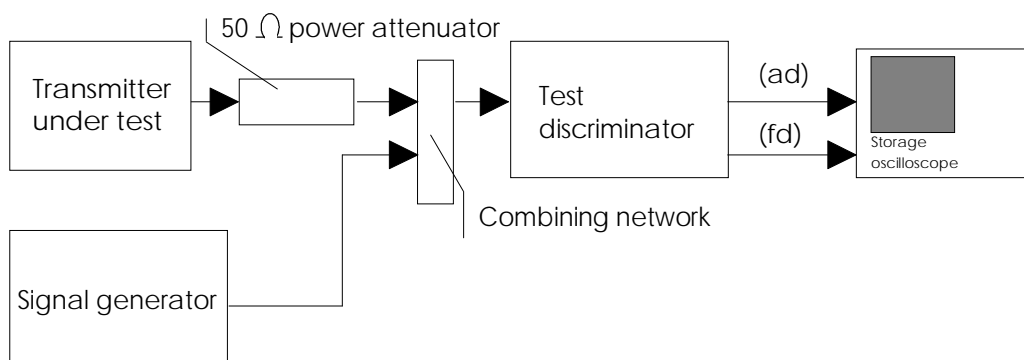

**Figure 3: Measurement arrangement**

Two signals shall be connected to the test discriminator via a combining network (subclause 6.2.2), figure 3.

The transmitter shall be connected to a 50 Ω power attenuator.

The output of the power attenuator shall be connected to the test discriminator via one input of the combining network.

A test signal generator shall be connected to the second input of the combining network.

The test signal shall be adjusted to the nominal frequency of the transmitter.

The test signal shall be modulated by a frequency of 1 kHz with a deviation of 25 kHz.

The test signal level shall be adjusted to correspond to 0,1 % of the power of the transmitter under test measured at the input of the test discriminator. This level shall be maintained throughout the measurement.

The amplitude difference (ad) and the frequency difference (fd) output of the test discriminator shall be connected to a storage oscilloscope.

The storage oscilloscope shall be set to display the channel corresponding to the (fd) input up to plus or minus one channel frequency difference, corresponding to the relevant channel separation, from the nominal frequency.

The storage oscilloscope shall be set to a sweep rate of 10 ms/division and set so that the triggering occurs at 1 division from the left edge of the display.

The display will show the 1 kHz test signal continuously.

The storage oscilloscope shall then be set to trigger on the channel corresponding to the amplitude difference (ad) input at a low input level, rising.

The transmitter shall then be switched on, without modulation, to produce the trigger pulse and a picture on the display.

The result of the change in the ratio of power between the test signal and the transmitter output will, due to the capture ratio of the test discriminator, produce two separate sides on the picture, one showing the 1 kHz test signal, the other the frequency difference of the transmitter versus time.

The moment when the 1 kHz test signal is completely suppressed is considered to provide  $t_{on}$ .

The periods of time  $t_1$  and  $t_2$  as defined in table 4 shall be used to define the appropriate template (figure 4).

The transmitter shall remain switched on.

The storage oscilloscope shall be set to trigger on the channel corresponding to the amplitude difference (ad) input at a high input level, decaying and set so that the triggering occurs at 1 division from the right edge of the display.

The transmitter shall then be switched off.

The moment when the 1 kHz test signal starts to rise is considered to provide  $t_{off}$ .

The period of time  $t_3$  as defined in the table shall be used to define the appropriate template (figure 4).

### **8.10.3 Limits**

The results shall be recorded as frequency difference versus time.

During the periods of time  $t_1$  and  $t_2$  the frequency difference shall not exceed the values given in subclause 8.10.1.

The frequency difference, after the end of  $t_2$ , shall be within the limit of the frequency error, subclause 8.1.

During the period of time  $t_3$  the frequency difference shall not exceed the values given in subclause 8.10.1.

Before the start of  $t_3$  the frequency difference shall be within the limit of the frequency error, subclause 8.1.

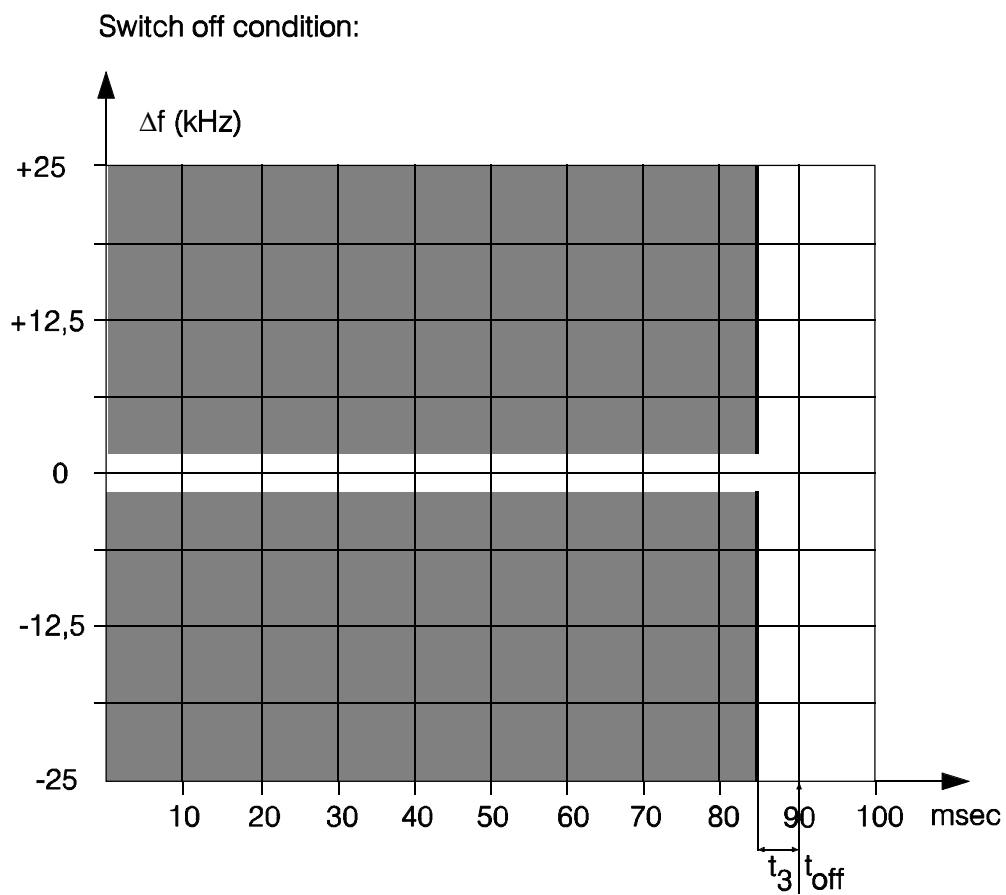
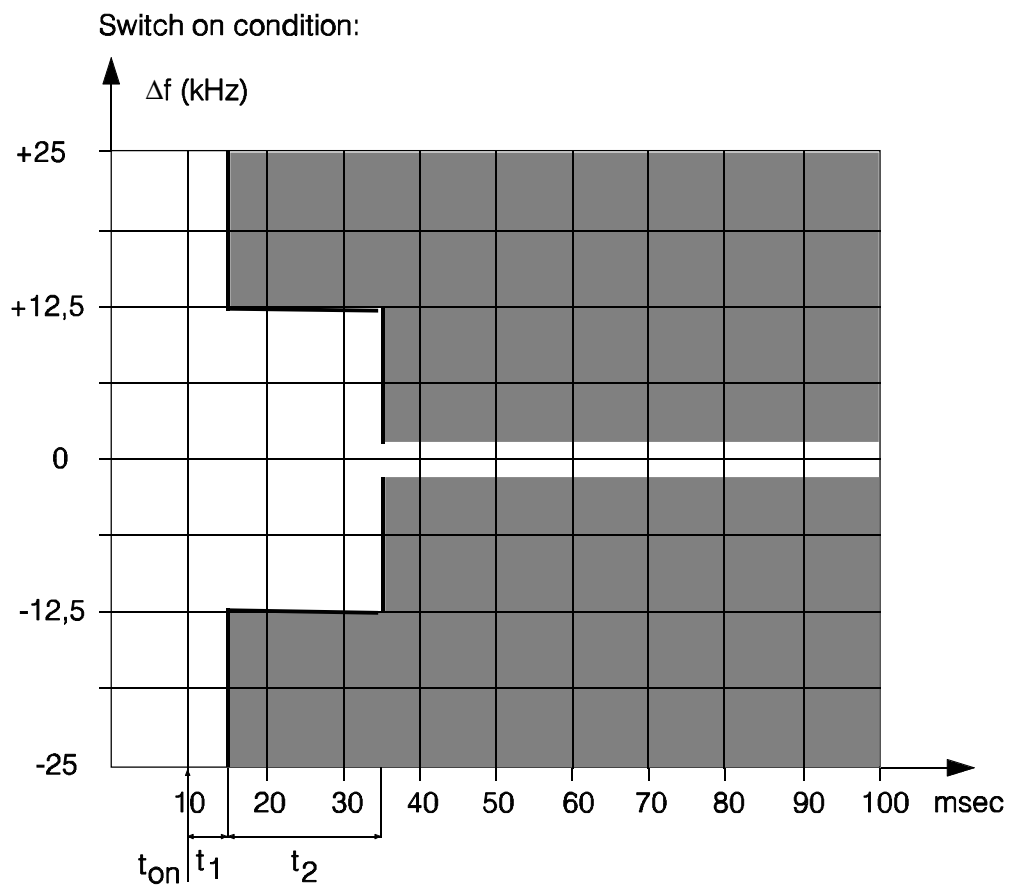

Figure 4



## **8.11 Conducted spurious emissions conveyed to the antenna**

### **8.11.1 Definition**

Conducted spurious emissions are emissions on a frequency or frequencies which are outside the necessary bandwidth and the level of which may be reduced without affecting the corresponding transmission of information. Spurious emissions include harmonic emissions, parasitic emissions, intermodulation products and frequency conversion products, but exclude out of band emissions.

### **8.11.2 Method of measurement**

Conducted spurious emissions shall be measured with the unmodulated transmitter connected to the artificial antenna (subclause 5.4).

The measurements shall be made over a range from 9 kHz to 2 GHz, excluding the channel on which the transmitter is operating and its adjacent channels.

The measurements for each spurious emission shall be made using a tuned radio measuring instrument or a spectrum analyzer.

### **8.11.3 Limit**

The power of any spurious emission on any discrete frequency shall not exceed 0,25  $\mu$ W.

## **9 Receiver**

### **9.1 Harmonic distortion and rated audio frequency output power**

#### **9.1.1 Definition**

The harmonic distortion at the receiver output port is defined as the ratio, expressed as a percentage, of the total rms voltage of all the harmonic components of the modulation audio frequency to the total rms voltage of the signal delivered by the receiver.

The rated audio frequency output power is the value stated by the manufacturer to be the maximum power available at the output port, for which all the requirements of this ETS are met.

#### **9.1.2 Methods of measurement**

Test signals at levels of + 60 dB $\mu$ V and + 100 dB $\mu$ V, at a carrier frequency equal to the nominal frequency of the receiver and modulated by the normal test modulation (subclause 5.3) shall be applied in succession to the receiver antenna port under the conditions specified in subclause 6.2.2.

For each measurement, the receiver's audio frequency volume control shall be set so as to obtain, in a resistive load which simulates the receiver's operating load, the rated audio frequency output power (subclause 9.1.1). The value of this load shall be stated by the manufacturer.

Under normal test conditions (subclause 5.3) the test signal shall be modulated successively at 300 Hz, 500 Hz and 1 kHz with a constant modulation index of 3. The harmonic distortion and audio frequency output power shall be measured at all the frequencies specified above.

Under extreme test conditions (subclauses 5.4.1 and 5.4.2 applied simultaneously), the tests shall be made at the receiver's nominal frequency and at the nominal frequency  $\pm$  1,5 kHz. For these tests, the modulation frequency shall be 1 kHz and the frequency deviation shall be  $\pm$  3 kHz.

### **9.1.3 Limits**

The rated audio frequency output power shall be at least:

- 200 mW in a loudspeaker;
- 1 mW in the handset earphone if provided.

The harmonic distortion shall not exceed 10 %.

## **9.2 Audio frequency response**

### **9.2.1 Definition**

The audio frequency response is defined as the variation in the receiver's audio frequency output level as a function of the modulation frequency of the radio frequency signal with constant deviation applied to its input.

### **9.2.2 Method of measurement**

A test signal of + 60 dB $\mu$ V, at a carrier frequency equal to the nominal frequency of the receiver and modulated with normal test modulation (subclause 5.3), shall be applied to the receiver antenna port under the conditions specified in subclause 6.2.2.

The receiver's audio frequency power control shall be set so as to produce a power level equal to 50 % of the rated output power (subclause 9.1). This setting shall remain unchanged during the test.

The frequency deviation shall then be reduced to 1 kHz.

The frequency deviation shall remain constant while the modulation frequency is varied between 300 Hz and 3 kHz and the output level shall then be measured.

The measurement shall be repeated with a test signal at frequencies 1,5 kHz above and below the nominal frequency of the receiver.

### **9.2.3 Limits**

The receiver response shall not deviate by more than + 1 dB or - 3 dB from a characteristic giving the output level as a function of the audio frequency, decreasing by 6 dB per octave and passing through the measured point at 1 kHz (figure 5).

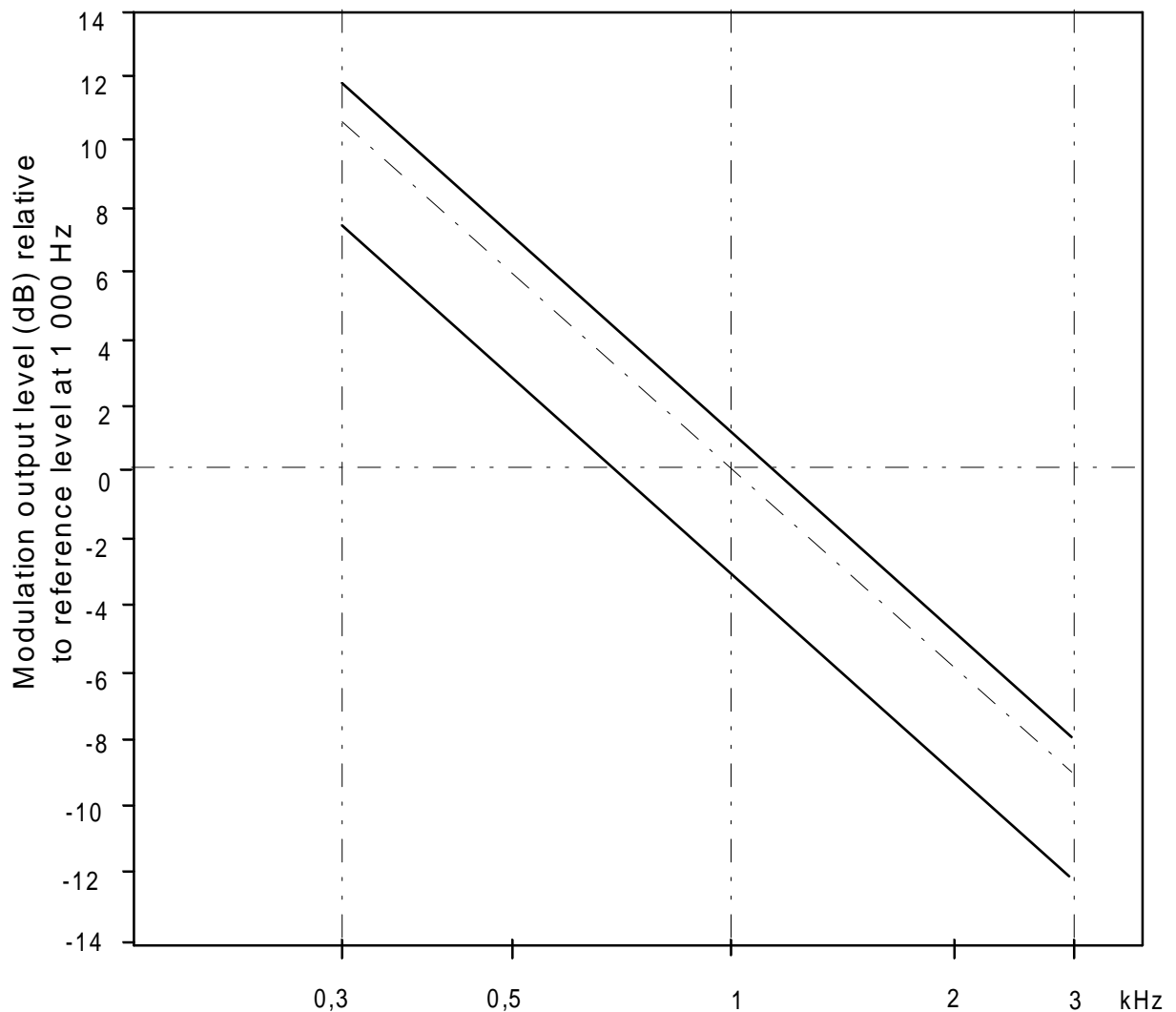

Figure 5: Audio frequency response

### 9.3 Maximum usable sensitivity

#### 9.3.1 Definition

The maximum usable sensitivity of the receiver is the minimum level of the signal at the nominal frequency of the receiver which, when applied to the receiver antenna port with normal test modulation (subclause 5.3), will produce:

- in all cases, an audio frequency output power equal to 50 % of the rated output power (subclause 9.1); and
- a SINAD ratio of 20 dB, measured at the receiver output port through a psophometric telephone filtering network such as described in ITU-T Recommendation P.53 [3].

#### 9.3.2 Method of measurement

A test signal at a carrier frequency equal to the nominal frequency of the receiver, modulated by the normal test modulation (subclause 5.3) shall be applied to the receiver antenna port. An audio frequency load and a measuring instrument for measuring the SINAD ratio (through a psophometric network as specified in subclause 9.3.1) shall be connected to the receiver output port.

The level of the test signal shall be adjusted until a SINAD ratio of 20 dB is obtained, using the psophometric network and with the receiver's audio frequency power control adjusted to produce 50 % of

the rated output power. The level of the test signal at the antenna port is the value of the maximum usable sensitivity.

The measurements shall be made under normal test conditions (subclause 5.3) and under extreme test conditions (subclauses 5.4.1 and 5.4.2 applied simultaneously).

A receiver output power variation of  $\pm 3$  dB relative to 50 % of the rated output power may be allowed for sensitivity measurements under extreme test conditions.

### **9.3.3 Limits**

The maximum usable sensitivity shall not exceed + 6 dB $\mu$ V under normal test conditions and + 12 dB $\mu$ V under extreme test conditions.

## **9.4 Co-channel rejection**

### **9.4.1 Definition**

The co-channel rejection is a measure of the capability of the receiver to receive a wanted modulated signal without exceeding a given degradation due to the presence of an unwanted modulated signal, both signals being at the nominal frequency of the receiver.

### **9.4.2 Method of measurement**

The two input signals shall be connected to the receiver antenna port via a combining network (subclause 6.2.2). The wanted signal shall have normal test modulation (subclause 5.3). The unwanted signal shall be modulated by 400 Hz with a deviation of 3 kHz. Both input signals shall be at the nominal frequency of the receiver under test. The measurement shall be repeated for displacements of the unwanted signal of  $\pm 3$  kHz.

The wanted input signal level shall be set to the value corresponding to the maximum usable sensitivity as measured in subclause 8.3. The amplitude of the unwanted input signal shall then be adjusted until the SINAD ratio (psophometrically weighted) at the output port of the receiver is reduced to 14 dB.

The co-channel rejection ratio shall be expressed as the ratio in dB of the level of the unwanted signal to the level of the wanted signal at the receiver antenna port for which the specified reduction in SINAD ratio occurs.

### **9.4.3 Limit**

The co-channel rejection ratio, at any frequency of the unwanted signal within the specified range, shall be between - 10 dB and 0 dB.

## **9.5 Adjacent channel selectivity**

### **9.5.1 Definition**

The adjacent channel selectivity is a measure of the capability of the receiver to receive a wanted modulated signal without exceeding a given degradation due to the presence of an unwanted modulated signal which differs in frequency from the wanted signal by 25 kHz.

### **9.5.2 Method of measurement**

The two input signals shall be applied to the receiver antenna port via a combining network (subclause 6.2.2). The wanted signal shall be at the nominal frequency of the receiver and shall have normal test modulation (subclause 5.3). The unwanted signal shall be modulated by 400 Hz with a deviation of 3 kHz, and shall be at a frequency 25 kHz above that of the wanted signal.

The wanted input signal level shall be set to the value corresponding to the maximum usable sensitivity as measured in subclause 9.3. The amplitude of the unwanted input signal shall then be adjusted until the SINAD ratio at the receiver output port, psophometrically weighted, is reduced to 14 dB. The measurement shall be repeated with an unwanted signal at a frequency 25 kHz below that of the wanted signal.

The adjacent channel selectivity shall be expressed as the lower value of the ratios in dB for the upper and lower adjacent channels of the level of the unwanted signal to the level of the wanted signal.

### **9.5.3 Limits**

The adjacent channel selectivity shall be not less than 70 dB.

## **9.6 Spurious response rejection**

### **9.6.1 Definition**

The spurious response rejection is a measure of the capability of the receiver to discriminate between the wanted modulated signal at the nominal frequency and an unwanted signal at any other frequency at which a response is obtained.

### **9.6.2 Method of measurement**

Two input signals shall be applied to the receiver antenna port via a combining network (subclause 6.2.2). The wanted signal shall be at the nominal frequency of the receiver and shall be modulated with normal test modulation (subclause 5.3).

The unwanted signal shall be modulated by 400 Hz with a deviation of 3 kHz.

The wanted input signal level shall be set to the value corresponding to the maximum usable sensitivity as measured in subclause 9.3. The amplitude of the unwanted input signal shall be adjusted to + 86 dB $\mu$ V. The frequency shall then be stepped over the frequency range from 100 kHz to 2 000 MHz in steps not larger than 0,5 Hz.

At any frequency at which a response is obtained, the input level shall be adjusted until the SINAD ratio psophometrically weighted, is reduced to 14 dB.

The spurious response rejection ratio shall be expressed as the ratio in dB between the unwanted signal and the wanted signal at the receiver antenna port when the specified reduction in the SINAD ratio is obtained.

### **9.6.3 Limit**

At any frequency separated from the nominal frequency of the receiver by more than 25 kHz, the spurious response rejection ratio shall be not less than 70 dB.

## **9.7 Intermodulation response**

### **9.7.1 Definition**

The intermodulation response is a measure of the capability of a receiver to receive a wanted modulated signal without exceeding a given degradation due to the presence of two or more unwanted signals with a specific frequency relationship to the wanted signal frequency.

### **9.7.2 Method of measurement**

Three signal generators, A, B and C shall be connected to the receiver antenna port via a combining network (subclause 6.2.2). The wanted signal, represented by signal generator A shall be at the nominal

frequency of the receiver and shall have normal test modulation (subclause 5.3). The unwanted signal from signal generator B shall be unmodulated and adjusted to the frequency 50 kHz above the nominal frequency of the receiver. The second unwanted signal from signal generator C shall be modulated by 400 Hz with a deviation of 3 kHz, and adjusted to a frequency 100 kHz above the nominal frequency of the receiver.

The wanted input signal shall be set to a value corresponding to the maximum usable sensitivity as measured in subclause 9.3. The amplitude of the two unwanted signals shall be maintained equal and shall be adjusted until the SINAD ratio at the receiver output port, psophometrically weighted, is reduced to 14 dB. The frequency of signal generator B shall be adjusted to produce the maximum degradation of the SINAD ratio. The level of the two unwanted test signals shall be readjusted to restore the SINAD ratio of 14 dB. The intermodulation response ratio shall be expressed as the ratio in dB between the two unwanted signals and the wanted signal at the receiver antenna port, when the specified reduction in the SINAD ratio is obtained.

The measurement shall be repeated with the unwanted signal from signal generator (B) at a frequency 25 kHz above the wanted signal and with the unwanted signal from signal generator (C) at a frequency 50 kHz above the wanted signal.

The set measurements described above shall be repeated with the unwanted signals below the nominal frequency by the specified amounts.

### **9.7.3 Limit**

The intermodulation response ratio shall be greater than 68 dB.

## **9.8 Conducted spurious emissions conveyed to the antenna**

### **9.8.1 Definition**

Conducted spurious emissions are components at any frequency generated in the receiver and radiated by its antenna.

The level of spurious emissions shall be measured by their power level in a transmission line or antenna.

### **9.8.2 Method of measurement**

Spurious radiations shall be measured as the power level of any discrete signal at the antenna port of the receiver. The receiver antenna port is connected to a spectrum analyzer or selective voltmeter having an input impedance of 50  $\Omega$  and the receiver is switched on.

If the detecting device is not calibrated in terms of power input, the level of any detected components shall be determined by a substitution method using a signal generator.

The measurements shall extend over the frequency range of 9 kHz to 2 GHz.

### **9.8.3 Limit**

The power of any spurious component between 9 kHz and 2 GHz shall not exceed 2 nW.

## **Annex A (normative): Adjacent channel power measurement**

This annex describes a method of measurement for adjacent channel power using a power measuring receiver (subclause 8.8.2).

The power measuring receiver specifications are given in clause A.2

### **A.1 Method of measurement**

The following procedure shall be used:

- a) the transmitter shall be operated at the carrier power determined in subclause 8.2 under normal test conditions. The antenna port of the transmitter shall be linked to the input of the power measuring receiver by a connecting device such that the impedance presented to the transmitter is  $50 \Omega$  and the level at the power measuring receiver input is appropriate;
- b) with the transmitter unmodulated, the tuning of the power measuring receiver shall be adjusted so that a maximum response is obtained. This is the 0 dB response point. The power measuring receiver attenuator setting and the reading of the meter shall be recorded;

The measurement may be made with the transmitter modulated with normal test modulation, in which case this fact shall be recorded with the test results.

- c) the tuning of the power measuring receiver shall be adjusted away from the carrier so that the power measuring receiver - 6 dB response nearest to the transmitter carrier frequency is located at a displacement from the nominal carrier frequency of 17 kHz;
- d) the transmitter shall be modulated at 1,25 kHz at a level which is 20 dB higher than that required to produce  $\pm 3$  kHz deviation;
- e) the power measuring receiver variable attenuator shall be adjusted to obtain the same meter reading as in step b) or a known relation to it;
- f) the ratio of adjacent channel power to carrier power is the difference between the attenuator settings in steps b) and e), corrected for any differences in the reading of the meter;
- g) the measurement shall be repeated with the power measuring receiver tuned to the other side of the carrier.

### **A.2 Power measuring receiver specification**

The power measuring receiver consists of a mixer, an IF filter, and oscillator, an amplifier, a variable attenuator and an rms value indicator. Instead of the variable attenuator with the rms value indicator it is also possible to use an rms voltmeter calibrated in dB. The technical characteristics of the power measuring receiver are given below.

#### **A.2.1 IF filter**

The IF filter shall be within the limits of the following selectivity characteristics (figure A.1).

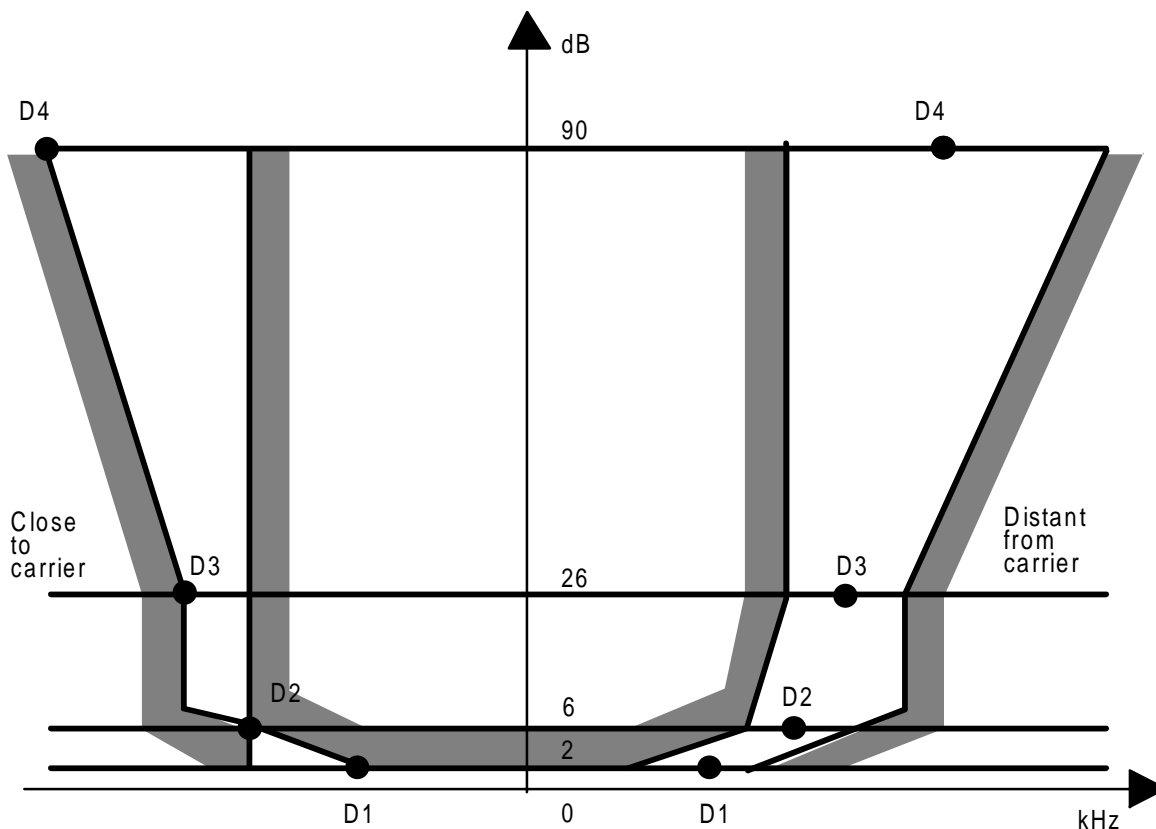

Figure A.1

The selectivity characteristic (table A.1) shall keep the following frequency separations from the nominal centre frequency of the adjacent channel:

Table A.1: Selectivity characteristic

Frequency separation of filter curve from nominal centre frequency of adjacent channel (kHz)			
D1	D2	D3	D4
5	8,0	9,25	13,25

The attenuation points close to carrier (table A.2) shall not exceed the tolerances shown in table A.2.

Table A.2: Attenuation points close to carrier

Tolerance range (kHz)			
D1	D2	D3	D4
+ 3,1	± 0,1	- 1,35	- 5,35

The attenuation points distant from the carrier (table A.3) shall not exceed the tolerances shown in table A.3.

Table A.3: Attenuation points distant from the carrier

Tolerance range (kHz)			
D1	D2	D3	D4
± 3,5	± 3,5	± 3,5	+ 3,5 - 7,5

The minimum attenuation of the filter outside the 90 dB attenuation points must be equal to or greater than 90 dB.



**A.2.2 Attenuation indicator**

The attenuation indicator shall have a minimum range of 80 dB and a reading accuracy of 1 dB. With a view to future regulations an attenuation of 90 dB or more is recommended.

**A.2.3 RMS value indicator**

The instrument shall accurately indicate non-sinusoidal signals with a crest factor of 10.

**A.2.4 Oscillator and amplifier**

The oscillator and the amplifier shall be designed in such a way that the measurement of the adjacent channel power of a low-noise unmodulated transmitter, whose self-noise has a negligible influence on the measurement result, yields a measured value of  $< -90$  dB.

## History

Document history	
April 1996	Public Enquiry PE 105: 1996-04-08 to 1996-08-30

