



EUROPEAN
TELECOMMUNICATION
STANDARD

FINAL DRAFT
pr **ETS 300 719-1**

April 1997

Source: ETSI TC-RES

Reference: DE/RES-04005-1

ICS: 33.020

Key words: Paging, private, radio

**Radio Equipment and Systems (RES);
Private wide area paging service;
Part 1: Technical characteristics for
private wide-area paging systems**

ETSI

European Telecommunications Standards Institute

ETSI Secretariat

Postal address: F-06921 Sophia Antipolis CEDEX - FRANCE

Office address: 650 Route des Lucioles - Sophia Antipolis - Valbonne - FRANCE

X.400: c=fr, a=atlas, p=etsi, s=secretariat - **Internet:** secretariat@etsi.fr

Tel.: +33 4 92 94 42 00 - Fax: +33 4 93 65 47 16

Copyright Notification: No part may be reproduced except as authorized by written permission. The copyright and the foregoing restriction extend to reproduction in all media.

© European Telecommunications Standards Institute 1997. All rights reserved.

Contents

Foreword	7
Introduction	8
1 Scope	9
2 Normative references	9
3 Definitions, symbols and abbreviations	9
3.1 Definitions	9
3.2 Symbols	10
3.3 Abbreviations	10
4 General	10
4.1 Presentation of radio paging equipment for testing purposes	10
4.1.1 Choice of model for type testing	11
4.1.2 Definition of alignment range	11
4.1.3 Definition of the categories of the alignment range (AR1 and AR2)	11
4.1.4 Choice of frequencies	11
4.1.5 Testing of equipment of category AR1	11
4.1.6 Testing of equipment of category AR2	11
4.2 Mechanical and electrical design	11
4.3 Controls	11
4.4 Transmitter shut-off facility	11
4.5 Receiver mute or squelch circuit	12
4.6 Auxiliary test equipment	12
4.7 Categories of emission	12
4.8 Presentation and interpretation of the measurement results	12
5 Test conditions, power sources and ambient temperatures	12
5.1 Normal and extreme test conditions	12
5.2 Normal operational test conditions	12
5.2.1 Normal temperature and humidity	12
5.2.2 Normal test power source	13
5.2.2.1 Mains supply	13
5.2.2.2 Other power sources	13
5.3 Extreme test conditions	13
5.3.1 Procedure for tests at extreme temperatures	13
5.3.2 Extreme temperature limits	14
5.3.3 Extreme test power source	14
5.3.4 Test power source	14
6 Electrical test conditions	15
6.1 Normal test signals and test modulation	15
6.1.1 Normal test signals for data	15
6.2 Artificial load	15
6.3 Test fixture for pocket receivers with an integral antenna	15
6.4 Test site and general arrangements for the measurement of radiated fields	16
6.5 Arrangements for test signals applied to the base station receiver input	16
7 Base station transmitter requirements	16
7.1 Frequency error	16
7.1.1 Definition	16
7.1.2 Method of measurement	16
7.1.3 Limits	17
7.2 Carrier power	17

	7.2.1	Definition.....	17
	7.2.2	Method of measurement.....	17
	7.2.3	Limits	17
7.3		Adjacent channel power.....	18
	7.3.1	Definition.....	18
	7.3.2	Method of measurement.....	18
	7.3.3	Limits	19
7.4		Spurious emissions	19
	7.4.1	Definition.....	19
	7.4.2	Method of measurement.....	19
		7.4.2.1 Method of measuring conducted spurious components	19
		7.4.2.2 Method of measuring radiated spurious components	20
	7.4.3	Limits	20
7.5		Transmitter transient behaviour	20
	7.5.1	Definition.....	20
		7.5.1.1 Keying criteria when the transmitter output power is switched on	21
		7.5.1.2 Keying criteria when the transmitter output power is switched off	21
	7.5.2	Method of measurement.....	22
	7.5.3	Limits	23
7.6		Transmitter intermodulation attenuation.....	23
	7.6.1	Definition.....	23
	7.6.2	Method of measurement.....	23
	7.6.3	Limit	24
8		Receiver requirements	24
	8.1	Pocket paging receivers.....	24
		8.1.1 Measured sensitivity for digital messages	24
		8.1.1.1 Definition	24
		8.1.1.2 Method of measurement.....	25
		8.1.1.3 Limits.....	25
	8.1.2	Co-channel rejection for digital messages.....	25
		8.1.2.1 Definition	25
		8.1.2.2 Method of measurement.....	26
		8.1.2.3 Limits.....	26
	8.1.3	Adjacent channel selectivity for digital messages.....	27
		8.1.3.1 Definition	27
		8.1.3.2 Method of measurement.....	27
		8.1.3.3 Limits.....	27
	8.1.4	Spurious response immunity for digital messages	28
		8.1.4.1 Definition	28
		8.1.4.2 Method of measurement.....	28
		8.1.4.3 Limit.....	28
	8.1.5	Blocking immunity or desensitization for digital messages.....	28
		8.1.5.1 Definition	28
		8.1.5.2 Method of measurement.....	29
		8.1.5.3 Limit.....	29
	8.1.6	Intermodulation immunity for digital messages	29
		8.1.6.1 Definition	29
		8.1.6.2 Method of measurement.....	30
		8.1.6.3 Limit.....	30
	8.1.7	Spurious emissions.....	31
		8.1.7.1 Definition	31
		8.1.7.2 Method of measurements	31
		8.1.7.3 Limits.....	31
	8.2	Base station receivers.....	31
		8.2.1 Measured sensitivity for digital messages	31
		8.2.1.1 Definition	31
		8.2.1.2 Method of measurement.....	31
		8.2.1.3 Limits.....	32
	8.2.2	Co-channel rejection for digital messages.....	32
		8.2.2.1 Definition	32

	8.2.2.2	Method of measurement.....	32
	8.2.2.3	Limits	33
8.2.3		Adjacent channel selectivity for digital messages	33
	8.2.3.1	Definition.....	33
	8.2.3.2	Method of measurement.....	33
	8.2.3.3	Limits	34
8.2.4		Spurious response immunity for digital messages.....	34
	8.2.4.1	Definition.....	34
	8.2.4.2	Method of measurement.....	34
	8.2.4.3	Limit	35
8.2.5		Blocking immunity or desensitization for digital messages	35
	8.2.5.1	Definition.....	35
	8.2.5.2	Method of measurement.....	35
	8.2.5.3	Limit	35
8.2.6		Intermodulation immunity for digital messages	35
	8.2.6.1	Definition.....	35
	8.2.6.2	Method of measurement.....	36
	8.2.6.3	Limit	36
8.2.7		Spurious emissions	37
	8.2.7.1	Definition.....	37
	8.2.7.2	Method of measurement.....	37
		8.2.7.2.1 Conducted spurious components	37
		8.2.7.2.2 Radiated spurious components	37
	8.2.7.3	Limits	37
9		Measurement uncertainty.....	37
	9.1	Absolute measurement uncertainties: maximum values	37
Annex A (normative):		Radiated measurements	39
A.1		Test sites and general arrangements for measurements involving the use of radiated fields	39
	A.1.1	Open air test site.....	39
		A.1.1.1 Standard position	39
	A.1.2	Test antenna.....	40
	A.1.3	Substitution antenna	40
	A.1.4	Optional additional indoor site.....	41
A.2		Guidance on the use of radiation test sites	41
	A.2.1	Measuring distance.....	42
	A.2.2	Test antenna.....	42
	A.2.3	Substitution antenna	42
	A.2.4	Artificial antenna	42
	A.2.5	Auxiliary cables	42
A.3		Further optional alternative indoor test site using an anechoic chamber	42
	A.3.1	Example of the construction of a shielded anechoic chamber	43
	A.3.2	Influence of parasitic reflections in anechoic chambers	43
	A.3.3	Calibration of the shielded RF anechoic chamber	43
Annex B (normative):		Simulated man (support for pocket equipment)	46
Annex C (normative):		Specification of power measuring receiver.....	47
C.1		IF filter	47
C.2		Attenuation indicator.....	48
C.3		RMS value indicator	48
C.4		Oscillator and amplifier.....	48
Annex D (normative):		Calculations of spurious responses frequencies.....	49

D.1	Introduction to the method.....	49
Annex E (normative):	Subclauses of this ETS relevant for compliance with the essential requirements of relevant EC Council Directives	50
Annex F (informative):	Private wide-area paging system basic services	51
Annex G (informative):	Bibliography	52
History		53

Foreword

This final draft European Telecommunication Standard (ETS) has been produced by the Radio Equipment and Systems (RES) Technical Committee of the European Telecommunications Standards Institute (ETSI), and is now submitted for the Voting phase of the ETSI standards approval procedure.

This ETS consists of two parts as follows:

Part 1: "Technical characteristics for private wide-area paging systems";

Part 2: "Functional characteristics and access protocol for private wide-area paging systems on shared channels".

This ETS has been produced by ETSI in response to a mandate from the European Commission issued under Council Directive 83/189/EEC (as amended) laying down a procedure for the provision of information in the field of technical standards and regulations.

This ETS, together with ETS 300 741, is intended to become a Harmonized Standard, the reference of which will be published in the Official Journal of the European Communities referencing the Council Directive on the approximation of the laws of the Member States relating to electromagnetic compatibility ("the EMC Directive") (89/336/EEC as amended).

Technical specifications relevant to the EMC Directive are given in annex E.

This ETS includes the following annexes:

- annex A is normative and specifies requirements concerning test sites and general arrangements for measurements involving the use of radiated fields;
- annex B is normative and specifies requirements for a simulated human body for measurements on pocket receivers;
- annex C is normative and specifies an adjacent channel power measuring receiver;
- annex D is normative and specifies the calculations of spurious response frequencies;
- annex E is normative and specifies the technical requirements relevant for compliance with the essential requirements the EMC Directive;
- annex F is informative and describes basic system services;
- annex G is informative and contains a bibliography.

Proposed transposition dates	
Date of latest announcement of this ETS (doa):	3 months after ETSI publication
Date of latest publication of new National Standard or endorsement of this ETS (dop/e):	6 months after doa
Date of withdrawal of any conflicting National Standard (dow):	6 months after doa

Introduction

Private Wide-Area Paging (PWAP) systems are basically On-Site Paging (OSP) systems with an extended range achieved by using a higher transmitter power (for guidance 25W could be a suitable value) and antenna location, as well as a specified receiver sensitivity. These systems can use time sharing in order to increase the number of virtual available channels. The time sharing as specified in part 2 of this ETS is a free running system that requires minimum overhead and supplies minimum loss of net-air time.

Potential applications include emergency services, hospitals and manufacturing industry that may be located at various sites within the covered area.

This ETS is based mainly on ETS 300 224, ETS 300 133 part 5, ESPA publication 4.2.7.

In preparing this ETS, much attention has been given to assure a low interference probability, while at the same time allowing a maximum flexibility and service to the end-user.

The conditions for licensing as well as conditions for interfacing to the Public Switched Telephone Network (PSTN) are determined by the appropriate authorities.

Additional standards or specifications may be required for equipment intended to interface to the Public Switched Telephone Network.

1 Scope

This European Telecommunication Standard (ETS) specifies the minimum performance characteristics and related methods of measurement for Private Wide-Area Paging (PWAP) systems operating on frequencies up to 470 MHz.

The types of equipment covered by this ETS are as follows:

- base station transmitters;
- base station receivers;
- base station transceivers;
- pocket receivers.

This ETS does not include performance characteristics that may be required by the user or requirements for interfacing equipment.

2 Normative references

This ETS incorporates by dated or undated reference, provisions from other publications. These normative references are cited at the appropriate places in the text and publications are listed hereafter. For dated references, subsequent amendments to or revisions of any of these publications apply to this ETS only when incorporated in it by amendment or revision. For undated references the latest edition of the publication referred to applies.

- [1] ETR 027: "Radio Equipment and Systems (RES); Methods of measurement for mobile radio equipment".
- [2] ETR 028: "Radio Equipment and Systems (RES); Uncertainties in the measurement of mobile radio equipment characteristics".

3 Definitions, symbols and abbreviations

3.1 Definitions

For the purposes of this ETS, the following definitions apply:

constant envelope modulation: Either phase or frequency modulation with or without pre-emphasis.

integral antenna: An antenna designed as an indispensable part of the equipment, with or without the use of an antenna connector.

messages: The transmission of information to a paging receiver. This information can be in the form of data or digital speech.

base station transceiver: A combination of a base station transmitter and a base station receiver.

base station transmitter: A transmitter fitted with an antenna socket and intended for use in a fixed location. This can be a stand-alone device or part of a transceiver.

base station receiver: A receiver fitted with an antenna socket and intended for use in a fixed location. This can be a stand-alone device or part of a transceiver.

full tests: All of the tests contained in this ETS and performed according to the appropriate methods of measurement.

pocket receiver: A pocket-sized receiver fitted with an integral antenna intended to be carried on a person.

preamble signal: A signal, needed in a system in which a battery saving system is used, in order to activate and prepare receivers for the subsequent calls.

test fixture: An apparatus for testing devices with an integral antenna.

salty man: Rotatable acrylic tube filled with salt water (annex B) to simulate the human body.

acceptance rate: the ratio of the number of messages received successfully to the number of messages transmitted.

3.2 Symbols

For the purposes of this ETS, the following symbols apply:

DM1, DM2, DM3	test signals defined in subclause 6.1.1
dBc	decibels relative to carrier
f_{cs}	channel spacing
rms	root-mean square
Rx	Receiver
T_{off}	switch-off instant
T_{on}	switch-on instant
Tx	Transmitter

3.3 Abbreviations

For the purposes of this ETS, the following abbreviations apply:

ad	amplitude difference
EMC	ElectroMagnetic Compatibility
emf	electro-motive force
erp	effective radiated power
fd	frequency difference
LF	Frequency range 30 kHz to 300 kHz (Low Frequency)
MPFD	Maximum Permissible Frequency Deviation
OATS	Open Air Test Site
OSP	On-Site Paging
PABX	Private Automatic Branch eXchange
POCSAG	Post Office Code Standardization Advisory Group
PSTN	Public Switched Telephone Network
PWAP	Private Wide-Area Paging
RF	Radio Frequency
RSSI	Received Signal Strength Indication
SIC	System Identification Code
SINAD	(Signal + Noise And Distortion)/(Noise + Distortion) ratio
VLF	Frequency range 3 kHz to 30 kHz (Very Low Frequency)
VSWR	Voltage Standing Wave Ratio

4 General

4.1 Presentation of radio paging equipment for testing purposes

Each equipment submitted for type testing shall fulfil the requirements of this ETS on all frequencies over which it is intended to operate.

To simplify and harmonize the type testing procedures between the different test laboratories, measurements shall be performed according to this ETS. The following subclauses are intended to give confidence that the requirements set out in this ETS have been met.

4.1.1 Choice of model for type testing

The manufacturer shall provide one or more production models of equipment, as appropriate, for type testing.

4.1.2 Definition of alignment range

The manufacturer shall, when submitting equipment for test, state the alignment range for the receiver or the transmitter. The alignment range is defined as the frequency range over which the receiver or the transmitter can be programmed and/or re-aligned to operate without any physical change of components other than programmable read only memories or crystals (for the receiver and the transmitter). For the purpose of all measurements the receiver and transmitter shall be considered separately.

4.1.3 Definition of the categories of the alignment range (AR1 and AR2)

Category AR1 corresponds to a limit of the alignment range of the receiver and transmitter which is less than, or equal to, 10 % of the highest frequency of the alignment range.

Category AR2 corresponds to a limit of the alignment range of the receiver and transmitter which is greater than 10 % of the highest frequency of the alignment range.

4.1.4 Choice of frequencies

The frequencies for testing shall be chosen by the manufacturer in accordance with subclauses 4.1.5 and 4.1.6.

4.1.5 Testing of equipment of category AR1

Full tests shall be carried out on a channel within 100 kHz of the centre frequency of the alignment range of one sample of the equipment.

4.1.6 Testing of equipment of category AR2

Full tests shall be carried out on three samples of the equipment, each sample aligned to a different channel.

The frequency of the channel of:

- the first sample shall be within 100 kHz of the lowest frequency of the alignment range;
- the second sample shall be within 100 kHz of the centre frequency of the alignment range;
- the third sample shall be within 100 kHz of the highest frequency of the alignment range.

4.2 Mechanical and electrical design

Station transmitters and receivers may be individual or combination units. The power source specified by the manufacturer shall be used for testing purposes.

4.3 Controls

Those controls, which if maladjusted can increase the capability of the equipment to cause interference, shall not be accessible without breaking a seal.

4.4 Transmitter shut-off facility

If the transmitter is fitted with an automatic shut-off facility, it shall be made inoperative for the duration of the tests.

4.5 Receiver mute or squelch circuit

If the receiver is equipped with a mute, squelch or battery-saving circuit, this circuit shall be made inoperative for the duration of the tests.

4.6 Auxiliary test equipment

All necessary test signal sources and setting up information shall accompany the equipment when it is submitted for type testing.

4.7 Categories of emission

Any type of constant envelope modulation, using analogue or digital modulating signals, which meets the limits of this ETS may be used.

4.8 Presentation and interpretation of the measurement results

The interpretation of the results recorded in a test report for the measurements described in this ETS shall be as follows:

- the measured value related to the corresponding limit shall be used to decide whether an equipment meets the requirements of this ETS;
- the measurement uncertainty value for the measurement of each parameter shall be included in the test report;
- the recorded value of the measurement uncertainty shall be, for each measurement, equal to or lower than the figures in table 8 (see clause 9).

The relevant application form and test report defined by CEPT should be used. If the application form and test report form for this ETS are not available, the relevant documents should be based on the model application form and the model test report form.

5 Test conditions, power sources and ambient temperatures

5.1 Normal and extreme test conditions

Type tests shall be made under normal operational conditions, and where stated under extreme conditions. The test conditions and procedures shall be as specified in subclauses 5.2 and 5.3.

5.2 Normal operational test conditions

5.2.1 Normal temperature and humidity

The normal temperature and humidity conditions for tests shall be any convenient combination of temperature and humidity within the following ranges:

- temperature: +15°C to +35°C;
- relative humidity: 20 % to 75 %.

When it is impracticable to carry out the tests under these conditions, a note to this effect, stating the ambient temperature and relative humidity during the tests, shall be added to the test report.

5.2.2 Normal test power source

5.2.2.1 Mains supply

The normal test voltage for equipment to be connected to the mains shall be the nominal mains voltage. For the purpose of type testing to this ETS, the nominal mains voltage shall be the declared voltage or any of the declared voltages for which the equipment was designed.

The frequency of the test power source corresponding to the ac mains shall be between 49 Hz and 51 Hz.

5.2.2.2 Other power sources

For operation from other power sources or types of battery (primary or secondary), the normal test voltage shall be that declared by the equipment manufacturer. Such values shall be stated in the test report.

In pocket equipment with integral antenna, the battery shall not be replaced with an external power source when making radiating measurements, because this external power source could influence the test results.

5.3 Extreme test conditions

5.3.1 Procedure for tests at extreme temperatures

Before measurements are made the equipment shall have reached thermal balance in the test chamber.

The equipment shall be switched to standby during the temperature stabilizing period.

In the case of equipment containing stabilization circuits designed to operate continuously, the temperature stabilization arrangements shall be switched on for 15 minutes after thermal balance has been obtained, and the equipment shall then meet the specified requirements. For such equipment the manufacturer shall provide for the power source circuit feeding the crystal oven to be independent of the power source to the rest of the equipment.

a) Procedure for equipment designed for continuous operation:

If the manufacturer states that the equipment is designed for continuous operation, the test procedure shall be as follows:

- before tests at the upper temperature, the equipment shall be placed in the test chamber and left until thermal balance is attained. The equipment shall then be switched on in the transmit condition for a period of half an hour, after which the equipment shall meet the specified requirements. For tests at the lower temperatures, the equipment shall be left in the test chamber until thermal balance is attained, after which the equipment shall meet the specified requirements.

b) Procedure for equipment designed for intermittent operation:

If the applicant states that the equipment is designed for intermittent operation, the test procedure shall be as follows:

- before tests at the upper extreme temperature are made, the equipment shall be placed in the test chamber and left until thermal balance is attained;

the equipment shall then either:

- transmit "on" and "off", according to the duty cycle as declared by the applicant, for a period of five minutes; or
- if the "on" period as declared by the applicant exceeds one minute, transmit in the "on" condition for a period not exceeding one minute, followed by a period in the "off" or "standby" mode for four minutes, after which the equipment shall meet the specified requirements.

For tests at the lower extreme temperature the equipment shall be left in the test chamber until thermal balance is attained, then the equipment shall be switched to the "standby" or "receive" condition for one minute, after which the equipment shall meet the specified requirements.

5.3.2 Extreme temperature limits

For tests at extreme temperatures, measurements shall be made in accordance with procedures specified in subclause 5.3.1 over the following ambient temperature range:

- base station equipment: -20°C to +55°C;
- pocket receiver equipment: -10°C to +55°C.

5.3.3 Extreme test power source

The power source voltage for tests under extreme voltage conditions shall be as follows:

- a) the extreme source voltages for equipment to be connected to an ac mains source shall be the nominal mains voltage $\pm 10\%$;
- b) when the equipment is intended for operation from the usual types of battery power sources, the extreme voltages shall be as follows:
 - where the equipment has a battery status indicator, the extreme voltages shall be the end point voltages indicated by the battery status indicator of the equipment under test;
 - where the equipment does not have a battery status indicator, and the manufacturer has not declared the end point voltages, the following end point voltages shall be used:
 - 1) Leclanché type of battery or Lithium type of battery:
 - 0,85 multiplied by the nominal voltage of the battery;
 - 2) Nickel-metal hydride or Nickel cadmium type of battery:
 - 0,9 multiplied by the nominal voltage of the battery;No upper extreme test voltages apply for 1) and 2).
 - 3) Equipment using other power sources:
 - for equipment using other power sources, or capable of being operated from a variety of power sources, the extreme test voltages shall be those agreed between the equipment manufacturer and the testing authority and shall be recorded in the test report.

5.3.4 Test power source

During type tests the power source of the equipment shall be replaced by a test power source, capable of producing normal and extreme test voltages as specified in subclauses 5.2.2 and 5.3.3. The internal impedance of the test power source shall be low enough to ensure that its effect on the test results is negligible. For the purpose of tests, the voltage of the power source shall be measured at the input terminals of the equipment.

If power to the equipment is provided from an external power source, the test voltages shall be those measured at the point of connection of the power cable to the equipment.

In battery operated equipment, the test power source shall be applied as close to the equipment battery supply terminals as practicable.

During the tests the test power source voltages shall be maintained within a tolerance of 1 % relative to the voltage at the beginning of each test.

6 Electrical test conditions

6.1 Normal test signals and test modulation

The test modulation signal is a baseband signal which modulates a carrier and is dependent upon the type of equipment under test and also the measurement to be performed.

6.1.1 Normal test signals for data

These test signals are defined as:

- D-M1: a test signal that produces the "space" (0) or "mark" (1) condition continuously;
- D-M2: a test signal that produces an alternating series of "space" (0) or "mark" (1) at the highest transmission rate;
- D-M3: a test paging signal shall be agreed between the test laboratory and the manufacturer in cases when selective messages are used and are generated or decoded within the equipment. The agreed test signal shall comprise a selective address and (depending upon pager type) a message consisting of 10 numeric characters or 20 alpha-numeric characters. The signal may be formatted and may contain error detection and correction.

The normal level of the test signal D-M3 shall produce a deviation of 20 % of the channel spacing or any other value as declared by the manufacturer as the normal operating level.

For test purposes if special equipment is required to generate the test signal D-M3 or to indicate the correct acceptance of the messages, it shall be supplied by the manufacturer.

6.2 Artificial load

Tests on the transmitters shall be carried out with a 50 Ω non-reactive non-radiating load, connected to the antenna terminal or test fixture terminal. The Voltage Standing Wave Ratio (VSWR) of the artificial load shall not exceed 1:1,2 over the frequency range of the measurements.

6.3 Test fixture for pocket receivers with an integral antenna

With equipment intended for use with an integral antenna, and not equipped with a 50 Ω output connection, the manufacturer may be required to supply a test fixture. This test fixture is a radio frequency coupling device for coupling the integral antenna to a 50 Ω radio frequency terminal at the working frequencies of the equipment under test. This allows certain measurements to be performed using conducted measuring methods. Only relative measurements may be performed using the test fixture.

If applicable the test fixture shall provide means to supply power to the pocket receivers under test.

The performance characteristics of the test fixture shall be agreed upon with the test laboratory and shall conform to the following basic parameters:

- the circuitry associated with the Radio Frequency (RF) coupling shall contain no active or non-linear devices;
- the coupling loss shall not influence the measuring results;
- the coupling loss shall be independent of the position of the test fixture and be unaffected by the proximity of surrounding objects or people;
- the coupling loss shall be reproducible when the equipment under test is removed and replaced;
- the coupling loss shall remain substantially constant when the environmental conditions are varied.

6.4 Test site and general arrangements for the measurement of radiated fields

Test sites shall be open air. The term "open air" should be understood from an electromagnetic point of view. Such a test site may be "outdoor" (really in open air) or alternatively "indoor" with walls and ceiling transparent to the radio waves at the frequencies considered. For these purposes, an anechoic room is considered "open air".

For guidance on test sites see ETR 027 [1], the relevant part of which is reproduced in annex A.

6.5 Arrangements for test signals applied to the base station receiver input

Sources of test signals for application to the receiver input shall be connected through a network such that the impedance presented to the receiver input is 50 Ω .

This requirement shall be met irrespective of whether one or more signals are applied to the receiver simultaneously.

The levels of the test signals shall be expressed in terms of electromotive force (emf) at the output terminals of the network prior to connection to the receiver input terminals.

The effects of any intermodulation products and noise produced in the signal generators should be negligible.

7 Base station transmitter requirements

In case of equipment with variable output power, all measurements shall be made using the highest rated power level. The equipment shall also be adjusted to the lowest rated output power setting and the measurements in the following subclauses shall be repeated: subclause 7.2 (carrier power), subclause 7.4 (spurious radiations) and subclause 7.5 (transmitter transient behaviour).

When making transmitter tests on equipment designed for intermittent operation, the maximum transmit time and duty cycle, as declared by the manufacturer, shall not be exceeded. The maximum transmit time shall be noted in the test report.

7.1 Frequency error

In case of equipment where it is not possible to obtain an unmodulated carrier, either the test in 7.1.2 b) or the test in subclause 7.3 under extreme conditions shall be carried out.

However, at the time of submission of the equipment for test, the applicant shall declare which test is applicable for the supplied equipment. The equipment under test shall fulfil the requirements of the declared test.

7.1.1 Definition

The frequency error of the transmitter is the difference between the unmodulated carrier frequency and its nominal value.

7.1.2 Method of measurement

The carrier frequency shall be measured by one of the following methods depending on whether the transmitter is capable of providing an unmodulated carrier:

- a) method of measurement where an unmodulated carrier is available:
 - the carrier frequency shall be measured in the absence of modulation with the transmitter connected to an artificial load. The measurement shall be made under normal test conditions and extreme test conditions (extreme temperature and supply voltage simultaneously).

- b) method of measurement where it is not possible to obtain an unmodulated carrier:
- 1) the transmitter output shall be connected to an artificial load;
 - 2) the emission shall be monitored by a frequency counter and the carrier frequency shall be measured with the transmitter set to continuously produce the carrier frequency representing the "space" condition (D-M1);
 - 3) the measurement shall be repeated with the transmitter set to continuously produce the carrier frequency representing the "mark" condition (D-M1);
 - 4) the unmodulated carrier frequency shall be obtained as the arithmetic mean of the two frequencies measured above.

The measurements shall be made under normal test conditions and repeated under extreme test conditions. Both extremes of voltage shall be applied at both extremes of temperature (subclauses 5.2 and 5.3 applied simultaneously).

The frequency error limits are given in table 1.

7.1.3 Limits

Table 1

Channel spacing (kHz)	Frequency error limits (kHz)			
	$f < 47$ MHz	$47 \leq f < 137$ MHz	$137 \leq f < 300$ MHz	$300 \leq f < 470$ MHz
10/12,5	±0,60	±1,00	±1,00	±1,00
20/25	±0,60	±1,35	±2,00	±2,00

7.2 Carrier power

7.2.1 Definition

The transmitter carrier power is the mean power during one unmodulated RF cycle delivered to an artificial load.

7.2.2 Method of measurement

The following method measurement shall be used:

- a) the transmitter shall be connected to an artificial load;
- b) the power delivered to this artificial load shall be measured. The value measured shall be compared with the rated output power;
- c) the measurement shall be made under normal test conditions and extreme test conditions (extreme temperature and supply voltage applied simultaneously, subclauses 5.2 and 5.3);
- d) the measurement should be performed in the absence of modulation. When it is not possible to measure in the absence of modulation, this fact shall be stated in the test report.

7.2.3 Limits

Under normal test conditions the measured carrier output power shall be within ±1,5 dB of the rated carrier output power. Under extreme test conditions the measured carrier output power shall be within +2,0 dB and -3,0 dB of the rated output power.

7.3 Adjacent channel power

7.3.1 Definition

The adjacent channel power is that part of the total output power of a transmitter modulated under a defined condition of modulation which falls within a specified passband centred on the nominal frequency of either of the adjacent channels. This power is the sum of the mean power produced by the modulation, hum and noise of the transmitter. It is specified either as the ratio expressed in decibels of the carrier power to the adjacent channel power or as an absolute value.

7.3.2 Method of measurement

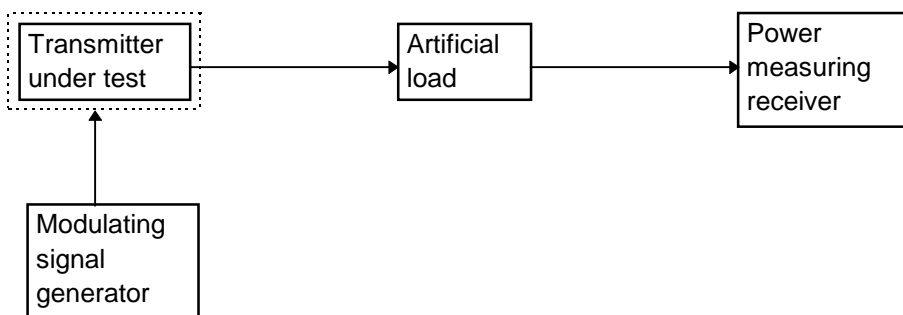

Figure 1: Measuring arrangement

Using the measuring arrangement given in figure 1, the adjacent channel power shall be measured with a power measuring receiver which conforms with annex C.

The method of measurement shall be as follows:

- a) the transmitter under test shall be connected via the artificial load to a measuring receiver calibrated to measure root mean square (rms) power levels. The level at the input of the measuring receiver shall be within its specified limit(s). The transmitter shall be operated at the highest rated carrier power level;
- b) with the transmitter unmodulated, the tuning of the power measuring receiver shall be adjusted so that a maximum response is obtained. This is the 0 dB response point. The power measuring receiver attenuator setting and the meter reading shall be recorded;

If a carrier can not be obtained, then the measurement shall be made with the transmitter modulated with the normal test signal D-M2 or D-M3 as appropriate.

- c) the tuning of the power measuring receiver shall be adjusted away from the carrier so that its -6 dB response nearest to the transmitter carrier frequency is located at a displacement from the nominal frequency of the carrier as given in table 2.

Table 2: Frequency displacement

Channel spacing (kHz)	Displacement (kHz)
10	5,75
12,5	8,25
20	13
25	17

The same result may be obtained by tuning the power measuring receiver (point D0 on the power measuring filter shape, given in figure C.1, to the nominal frequency of the adjacent channel, if it has been suitably calibrated;

- d) the transmitter shall be modulated in accordance with subclause 6.1.2 with the normal coded test signal D-M2/D-M3, whichever is appropriate, at the input level declared by the manufacturer;

- e) the power measuring receiver variable attenuator shall be adjusted to obtain the same meter reading as in step b) or a known relation to it. This value shall be recorded;
- f) the ratio of adjacent channel power to carrier power is the difference between the attenuator settings in steps b) and e), corrected for any differences in the reading of the meter. Alternatively the absolute value of the adjacent channel power may be calculated from the above ratio and the transmitter carrier power;
- g) steps c) to f) shall be repeated with the power measuring receiver tuned to the other side of the carrier;
- h) in cases where the applicant has declared that the adjacent channel power is to be measured at extreme conditions instead of measuring the frequency error (see subclause 7.1), this measurement shall be repeated under extreme test conditions (subclauses 5.2 and 5.3 applied simultaneously).

7.3.3 Limits

The limits for the adjacent channel power under normal and extreme conditions are given in table 3.

Table 3

Channel spacing (kHz)	Limit under normal conditions	Limit under extreme conditions
10 or 12,5	60 dB below carrier power, without the need to be below 0,2 μW	55 dB below carrier power, without the need to be below 0,2 μW
20/25	70 dB below carrier power, without the need to be below 0,2 μW	65 dB below carrier power, without the need to be below 0,2 μW

7.4 Spurious emissions

7.4.1 Definition

Spurious emissions are discrete radio frequencies signals other than those of the carrier and sidebands associated with normal modulation.

The level of spurious emissions shall be measured as their power level into a specified load (conducted spurious components) and their effective radiated power when radiated by the cabinet and structure of the equipment (radiated spurious components).

7.4.2 Method of measurement

7.4.2.1 Method of measuring conducted spurious components

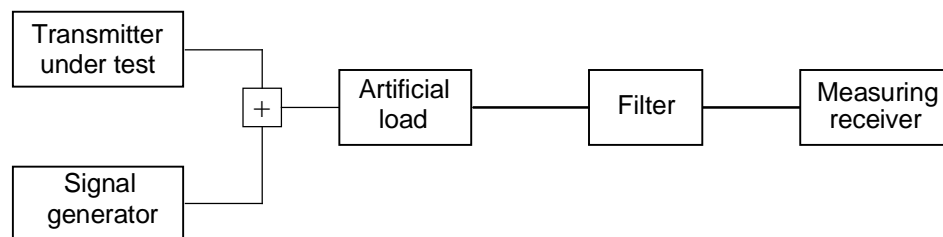

Figure 2: Measuring arrangement

Conducted spurious components shall be measured as the power level of any discrete signal delivered into a 50 Ω load. This may be done by connecting the transmitter output through an attenuator to a measuring receiver, or by monitoring the relative levels of the spurious signals delivered to an artificial load.

The transmitter shall be unmodulated if possible, and the measurements shall be made in the frequency range 9 kHz - 4 GHz except for the channel on which the transmitter is intended to operate and its adjacent channels.

If an unmodulated carrier can not be obtained, the measurement shall be made with the transmitter modulated by the normal test signal D-M3 (subclause 6.1.2), in which case this fact shall be recorded in the test report.

The measurement shall be repeated with the transmitter in the stand-by position.

7.4.2.2 Method of measuring radiated spurious components

On a test site, fulfilling the requirements of subclause 6.4, the sample shall be placed at the specified height on the support.

The transmitter shall be unmodulated if possible, and the radiation of any spurious component shall be detected by the test antenna and receiver, over the frequency range 25 MHz - 4 GHz, except for the channel on which the transmitter is intended to operate and its adjacent channels.

If an unmodulated carrier cannot be obtained, the measurement shall be made with the transmitter modulated by the normal test signal D-M3 (subclause 6.1.2), in which case this fact shall be recorded in the test report.

At each frequency at which a component is detected, the sample shall be rotated to obtain a maximum response and the effective radiated power (erp) of that component determined by a substitution measurement.

The measurements shall be repeated with the test antenna in the orthogonal polarization plane.

The measurements shall be repeated with the transmitter in the stand-by position.

The bandwidth used in this measurement for each spurious radiation shall be sufficiently wide to accept all significant components of the spurious radiation concerned. The conditions used in the relevant measurements shall be recorded in the test report. It is assumed that a -6 dB bandwidth of 120 kHz is sufficiently wide and a correct value for this measurement.

7.4.3 Limits

The power of any spurious component, conducted or radiated, shall not exceed the values given in table 4.

Table 4

Transmitter state	Other frequencies below $f < 1\ 000$ MHz	Frequencies above 1 000 MHz
Operating	250 nW	1 μ W
Stand by	2 nW	20 nW

7.5 Transmitter transient behaviour

7.5.1 Definition

The transient behaviour of transmitters is determined by the time-dependency of the transmitter frequency and the transmitter power, when the transmitter output power is switched "on" and "off". Only the transient behaviour of the transmitter carrier frequency shall be measured.

The following frequency tolerances and transient times are specified:

- f_0 : frequency tolerance in the steady state;
- f_1 : frequency difference which shall be less than one channel separation;
- f_2 : frequency difference which shall not be greater than half the channel separation;
- t_1 : period of time during which frequency tolerance f_1 applies;
- t_2 : period of time during which frequency tolerance f_2 applies;
- t_3 : period of time during which the frequency error on the carrier applies;
- t_{on} : period of time during which frequency tolerance f_0 applies.

According to the method of measurement described in subclause 7.5.2, the switch-on instant (T_{on}) of a transmitter is defined by the condition when the output power, measured at the antenna terminal, exceeds 10 % of the nominal power or 100 mW whichever is lower. The switch-off instant (T_{off}) is given when the nominal power falls below this limit.

The different frequency tolerance schemes have to be applied for the following cases.

7.5.1.1 Keying criteria when the transmitter output power is switched on

The transient times and frequency tolerances are shown in figure 3.

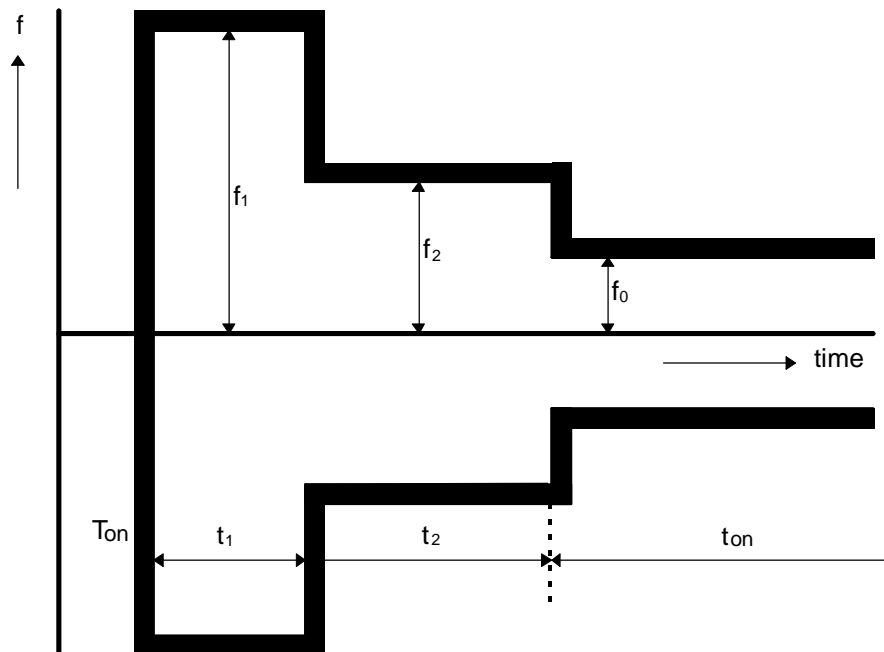

Figure 3

7.5.1.2 Keying criteria when the transmitter output power is switched off

The transient time is not subdivided; the frequency tolerance is shown in figure 4.

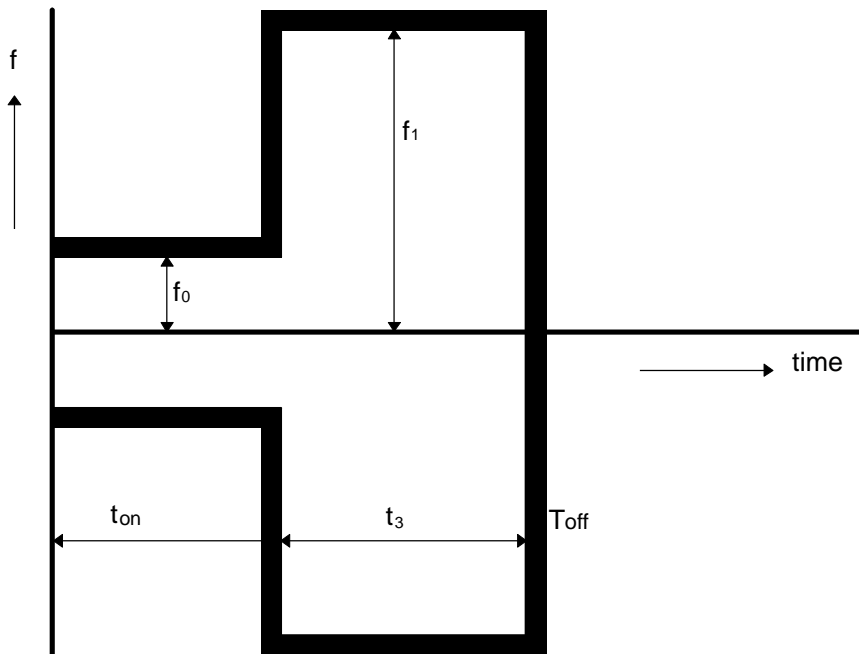

Figure 4

7.5.2 Method of measurement

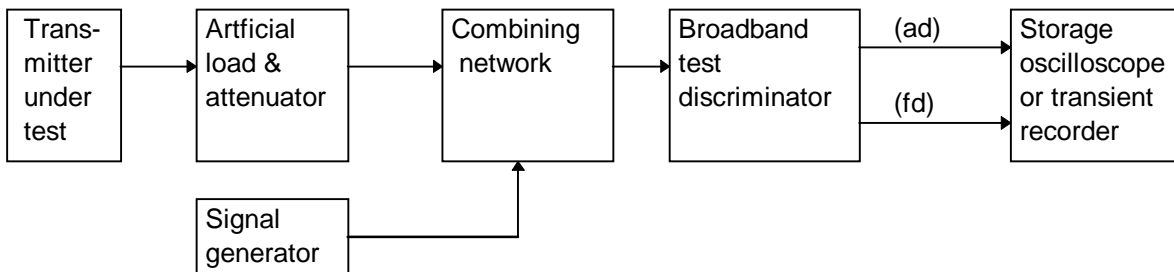

Figure 5: Measuring arrangement

Using figure 5 the signals of the transmitter under test and the signal generator shall be connected to the test discriminator via a combining network. The transmitter shall be connected to a 50 Ω power attenuator. The output of the power attenuator shall be connected to the test discriminator via one input of the combining network. A test signal generator shall be connected to the second input of the combining network.

The signal generator shall be adjusted to the nominal frequency of the transmitter. The test signal shall be modulated by a frequency of 1 kHz with a deviation equal to ± the value of the relevant channel separation. The test signal level shall be adjusted to correspond to 0,1 % of the power of the transmitter under test measured at the input of the test discriminator. This level shall be maintained throughout the measurement.

The amplitude difference (ad) and the frequency difference (fd) output of the test discriminator shall be connected to a storage oscilloscope. The storage oscilloscope shall be set to display the channel corresponding to the (fd) input up to ±1 channel frequency difference, corresponding to the relevant channel separation, from the nominal frequency. The storage oscilloscope shall be set to a sweep rate of 10 ms/division and set so that the triggering occurs at 1 division from the left edge of the display. The display will show the 1 kHz test signal continuously. The storage oscilloscope shall then be set to trigger on the channel corresponding to the amplitude difference (ad) input at a low input level, rising.

The transmitter shall then be switched on, without modulation, to produce the trigger pulse and a picture on the display. The result of the change in the ratio of power between the test signal and the transmitter output will, due to the capture ratio of the test discriminator, produce two separate sides on the picture, one showing the 1 kHz test signal, the other the frequency difference of the transmitter versus time. The moment when the 1 kHz test signal is completely suppressed is considered to mark the beginning of "t_{on}". The periods of time "t₁" and "t₂", as defined in subclause 7.5.1, shall be used to define the appropriate template.

During the period of time "t₁" and "t₂" the frequency difference shall not exceed the values given in subclause 7.5.3. The frequency difference, after the end of t₂ shall be within the limits of the frequency error, subclause 7.1.3. The results shall be recorded as frequency difference versus time.

The transmitter shall remain switched on. The storage oscilloscope shall be set to trigger on the channel corresponding to the amplitude difference (ad) input at a high input level, decaying and set so that the triggering occurs at 1 division from the right edge of the display. The transmitter shall then be switched off.

The moment when the 1 kHz test signal starts to rise is considered to mark the beginning of "t_{off}". The period of time "t₃" as defined in subclause 7.5.1, shall be used to define the appropriate template. During the period of time "t₃" the frequency difference shall not exceed the values given in subclause 7.5.3. Before the start of "t₃" the frequency difference shall be within the limit of the frequency error, given in table 1 in subclause 7.1.3. The result shall be recorded as frequency difference versus time.

7.5.3 Limits

Table 5: Transmitters transient limits

Transient time	Carrier frequency ≤ 300 MHz	Carrier frequency > 300 MHz	Maximum frequency difference
t ₁	5 ms	10 ms	1,0 channel separation
t ₂	20 ms	25 ms	0,5 channel separation
t ₃	5 ms	10 ms	1,0 channel separation
NOTE: For pocket transmitters there is no limitation.			

7.6 Transmitter intermodulation attenuation

7.6.1 Definition

For the purpose of this ETS, the intermodulation attenuation is a measure of the capability of a transmitter to inhibit the generation of signals in its non-linear elements caused by the interaction of its carrier with an interfering external signal entering the transmitter through its output terminal (i.e. from the antenna).

7.6.2 Method of measurement

The output of the transmitter under test shall be connected to a signal source via a coupling device presenting to the transmitter a load with an impedance of 50 Ω.

The coupling device may consist of a circulator, one port of which is connected by a coaxial cable to the output terminal of the transmitter and the second port is correctly terminated (nominal value 50 Ω). This termination is provided with means for connection to a selective measuring device (e.g. a spectrum analyser). The third port of the circulator is connected to the test signal source by means of an isolator.

Alternatively, the coupling device may consist of a resistive attenuator, which may be combined with an isolator, one end of which is connected to the output terminal of the transmitter by coaxial cable and the other end is connected to the test signal source. A selective measuring device is connected to the transmitter end of the attenuator by means of a sampling probe, giving the required attenuation.

The transmitter under test and the test signal source shall be physically separated in such a way that the measurement is not influenced by direct radiation.

The test signal shall be unmodulated and the frequency shall be within one to four neighbouring channels above the frequency of the transmitter under test. The frequency shall be chosen so that the intermodulation components to be measured do not coincide with spurious emissions measured in subclause 7.4. The test signal power level shall be adjusted to -30 dB relative to the carrier power level of the transmitter (subclause 7.2) both levels being measured at the output of the transmitter. The power level of the test signal shall be measured at the transmitter end of the coaxial cable when disconnected from the transmitter and correctly matched (nominal value 50 Ω).

NOTE: Since the impedance that the transmitter presents to the test signal is unknown, the test signal level can not be measured, or its amplitude compared with that of the intermodulation components, while the transmitter is connected.

The output power of the transmitter shall be measured directly at the output terminal connected to an artificial load (subclause 6.2).

With the transmitter switched on in an unmodulated condition the levels of the transmitter carrier and the intermodulation components shall be compared by means of the selective measuring device.

Where it is impossible to obtain a carrier output from the transmitter in the absence of modulation, this test shall be carried out with the transmitter modulated.

The length of the coaxial cable between the transmitter output and the coupling device shall be varied until the maximum level of the intermodulation component considered is obtained.

This measurement shall be repeated with the test signal at a frequency within one to four neighbouring channels below the transmitter frequency.

When the above measurements are performed, precautions should be taken so that non-linearities in the selective measuring device do not influence the results appreciably. Furthermore it should be ensured that intermodulation components which may be generated in the test signal source, are attenuated sufficiently, e.g. by means of a circulator.

The intermodulation attenuation shall be expressed in decibels as the ratio of the test signal power level to the power level of an intermodulation component.

7.6.3 Limit

The intermodulation attenuation shall be at least 40 dB for any intermodulation component.

This may be achieved by means of isolating devices, such as circulators, which shall be supplied at the time of testing.

NOTE: The test method detailed in subclause 7.6.2 is carried out for the purpose of type approval only, to demonstrate that the transmitter and associated isolating device meet the limit. In practice it may not be necessary to fulfil this limit, as it will be dependent on the site at which the transmitter is located.

However, the requirement to meet the intermodulation attenuation limit can be a condition of granting a licence.

8 Receiver requirements

8.1 Pocket paging receivers

8.1.1 Measured sensitivity for digital messages

8.1.1.1 Definition

The measured sensitivity for messages expressed as field strength is the average of eight measurements of field strength, expressed in dB μ V/m, at the nominal frequency of the receiver and with specified test modulation which produces after demodulation a message acceptance rate of 80 %, when the receiver is rotated in 45° increments, starting at the reference orientation.

8.1.1.2 Method of measurement

The measurement shall be performed on a test site fulfilling the requirements of subclause 6.4 in the specified frequency range. The test antenna shall be oriented for vertical polarization and shall not be varied in height.

The following method of measurement shall be used:

- a) a signal generator shall be connected to the test antenna. The signal generator shall be at the nominal frequency of the receiver and shall be modulated by the test signal D-M3 (subclause 6.1.2). The receiver under test shall be placed on the "salty man" at $1,5 \text{ m} \pm 0,1 \text{ m}$ (annex B) above ground level. The manufacturer should specify which face of the receiver under test should be normal to the direction of the test antenna. This is the reference orientation for the measurement;
- b) the level of the RF signal shall be such that a message acceptance rate of less than 10 % is obtained;
- c) the test signal shall be transmitted repeatedly whilst observing in each case whether or not a successful response is obtained. The test level shall be increased by 2 dB for each occasion that a successful response is not obtained. The procedure shall be continued until three consecutive successful responses are observed. The level of the test signal shall be recorded;
- d) the test signal level shall be reduced by 1 dB and the new value recorded. The test signal shall then be continuously repeated. In each case, if a response is not obtained, the test level shall be increased by 1 dB and the new value recorded. If a successful response is obtained, the test level shall not be changed until three consecutive successful responses have been observed. In this case the test level shall be reduced by 1 dB and the new value recorded. No test signal levels shall be recorded unless preceded by a change in level. The measurement shall be stopped after 10 values have been recorded;
- e) the mean average of the dB values recorded in step d) shall be calculated;
- f) steps b) to e) above shall be repeated for the eight positions, 45° apart, of the receiver and the corresponding average values of the test signal shall be determined and noted;
- g) using the calibration of the test site, the eight field strength values X_i ($\mu\text{V}/\text{m}$) corresponding to the eight average values determined in step f) shall be calculated. The average measured sensitivity expressed as field strength X_{mean} ($\text{dB}\mu\text{V}/\text{m}$) is given by:

$$X_{\text{mean}} = 20 \log_{10} \left[\frac{8}{\sum_{i=1}^8 \frac{1}{X_i^2}} \right]^{\frac{1}{2}}$$

The steps b) to e) shall be repeated with the receiver placed in the test fixture and the signal generator connected directly to the test fixture. The mean value resulting from step e) shall be used as the reference value for the sensitivity as needed in subclauses 8.1.2.2, 8.1.3.2, 8.1.4.2 and 8.1.5.2.

8.1.1.3 Limits

The measured sensitivity value shall not exceed +36 dB $\mu\text{V}/\text{m}$ under normal test conditions.

8.1.2 Co-channel rejection for digital messages

8.1.2.1 Definition

The co-channel rejection for messages is a measure of the capability of the receiver to receive a wanted modulated signal at the nominal frequency without exceeding a given degradation due to the presence of an unwanted modulated signal, also at the nominal frequency.

It is specified as the ratio in dB of the level of the unwanted signal to the specified wanted signal level at the receiver input, for which the message acceptance rate is 80 %.

8.1.2.2 Method of measurement

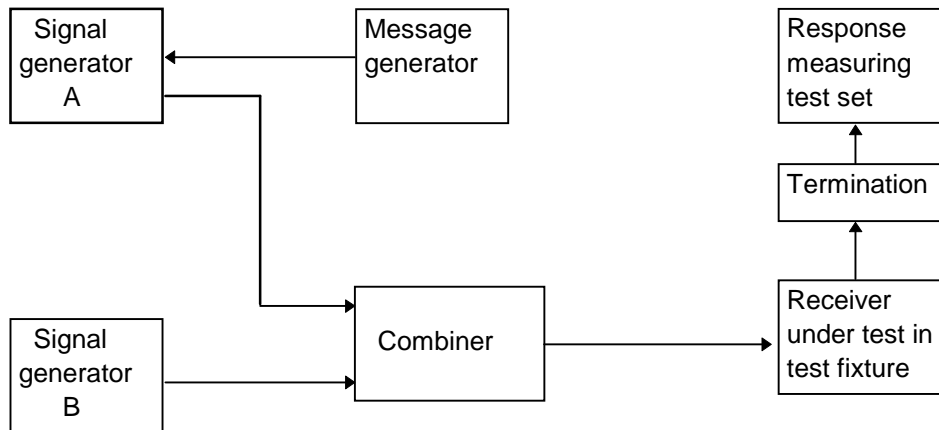

Figure 6: Measuring arrangement

The method of measurement shall be as follows:

- two signal generators, A and B, shall be connected to the test fixture input via a combining network. The wanted signal, represented by generator A, shall be at the nominal frequency and modulated with test signal D-M3 (subclause 6.1.2). The signal level of generator A shall be 3 dB above the measured reference sensitivity level for messages (see subclause 8.1.1.2);
- the unwanted signal, represented by generator B, shall also be at the nominal frequency and modulated with the test signal D-M3 (subclause 6.1.1) and the level adjusted until an acceptance rate of less than 10 % is obtained;
- the level of the unwanted signal shall be reduced by 2 dB for each occasion that a successful response is not observed. The procedure shall be continued until three consecutive successful responses are observed. The level of the unwanted signal shall then be recorded;
- the unwanted signal shall then be increased by 1 dB and the new value recorded. The measurement shall then be continuously repeated. In each case if a response is not obtained the level of the unwanted signal shall be reduced by 1 dB and the new value recorded. If a successful response is obtained, the level of the unwanted signal shall not be changed until three consecutive responses have been obtained. In this case the unwanted signal shall be increased by 1 dB and the new value recorded. No levels of the unwanted signal shall be recorded unless preceded by a change in level. The measurement shall be stopped after 10 values have been recorded;
- the co-channel rejection ratio for messages shall be recorded as the ratio in dB of the average of the levels of the unwanted signal recorded in steps c) and d) to the level of the wanted signal, at the test fixture input.

8.1.2.3 Limits

The co-channel rejection ratio shall be between:

- 8 dB and 0 dB for a channel spacing of 20 kHz and 25 kHz;
- 12 dB and 0 dB for a channel spacing of 10 kHz and 12,5 kHz.

8.1.3 Adjacent channel selectivity for digital messages

8.1.3.1 Definition

The adjacent channel selectivity for messages is a measure of the capability of the receiver to receive a wanted modulated signal at the nominal frequency without exceeding a given degradation due to the presence of an unwanted modulated signal which differs in frequency from the wanted signal by an amount equal to the adjacent channel spacing for which the equipment is intended.

It is specified as the lower value of the ratios in dB for the upper and lower adjacent channels of the level of the unwanted signal to a specified level of the wanted signal, for which the message acceptance rate is 80 %.

8.1.3.2 Method of measurement

The test arrangement shown in figure 6 shall be used with the following test method:

- a) two signal generators, A and B, shall be connected to the test fixture input via a combining network. The wanted signal, represented by generator A, shall be at the nominal frequency and modulated with the test signal D-M3 (subclause 6.1.2). The signal level of generator A shall be 3 dB above the measured reference sensitivity level for messages (see subclause 8.1.1.2);
- b) the unwanted signal, modulated by the test signal D-M3 (subclause 6.1.1) and represented by generator B, shall be at the channel frequency immediately above that of the wanted signal. The level of generator B shall be adjusted until a message acceptance rate of less than 10 % is obtained;
- c) the level of the unwanted signal shall be reduced by 2 dB for each occasion that a successful response is not observed. The procedure shall be continued until three consecutive successful responses are observed. The level of the unwanted signal shall then be recorded;
- d) the unwanted signal shall then be increased by 1 dB and the new value recorded. The measurement shall then be continuously repeated. In each case a response is not obtained the level of the unwanted signal shall be reduced by 1 dB and the new value recorded. If a successful response is obtained, the level of the unwanted signal shall not be changed until three consecutive successful responses have been obtained. In this case the unwanted signal shall be increased by 1 dB and the new value recorded. No levels of the unwanted signal shall be recorded unless preceded by a change in level. The measurement shall be stopped after 10 values have been recorded;
- e) the measurement shall be repeated with the unwanted signal at the frequency of the channel below that of the wanted signal;
- f) the adjacent channel selectivity for messages shall be recorded for the upper and lower adjacent channels as the ratio of the average of the levels of the wanted signal, recorded in steps c) and d), to the level of the wanted signal.

8.1.3.3 Limits

The lower value of the adjacent channel selectivity of the upper and lower adjacent channels for the respective channel spacing shall not be less than the value given in table 6.

Table 6

Conditions	Channel spacing	
	10/12,5 kHz	20/25 kHz
normal	56 dB	60 dB
extreme	50 dB	54 dB

8.1.4 Spurious response immunity for digital messages

8.1.4.1 Definition

The spurious response immunity for messages is a measure of the capability of the receiver to receive a wanted signal at the nominal frequency without exceeding a given degradation due to the presence of an unwanted modulated signal at any other frequency that differs from the wanted signal by more than one channel spacing, and at which a response is obtained.

It is specified as the value of the ratios in dB of the level of the unwanted signal to a specified level of the wanted signal for which the message acceptance rate is 80 %.

8.1.4.2 Method of measurement

The test arrangement shown in figure 6 shall be used with the following test method:

- a) two signal generators, A and B, shall be connected to the test fixture input via a combining network. The wanted signal, represented by generator A, shall be at the nominal frequency and modulated with the test signal D-M3 (subclause 6.1.2). The signal level of generator A shall be adjusted to 3 dB above the measured reference sensitivity level for messages (see subclause 8.1.1.2);
- b) the frequency of the unwanted signal, modulated by the test signal D-M3 (subclause 6.1.1) and represented by generator B shall be adjusted to a frequency within the specified frequency range at which it is calculated according to annex D that a spurious response could occur. The level of the unwanted modulated signal shall be adjusted until a message acceptance rate of less than 10 % is obtained;
- c) the level of the unwanted signal shall be reduced by 2 dB for each occasion that a successful response is not observed. The procedure shall be continued until three consecutive successful responses are observed. The level of the unwanted signal shall then be recorded;
- d) the unwanted signal shall then be increased by 1 dB and the new value recorded. The measurement shall then be continuously repeated. In each case a response is not obtained the level of the unwanted signal shall be reduced by 1 dB and the new value recorded. If a successful response is obtained, the level of the unwanted signal shall not be changed until three consecutive successful responses have been obtained. In this case the unwanted signal shall be increased by 1 dB and the new value recorded. No levels of the unwanted signal shall be recorded unless preceded by a change in level. The measurement shall be stopped after 10 values have been recorded;
- e) the measurement shall be repeated at each frequency within the specified frequency range at which it is calculated that a spurious response could occur;
- f) the spurious response immunity for messages shall be recorded for the frequency concerned as the ratio in dB of the average of the levels of the unwanted signal recorded in steps c) and d) to the level of the wanted signal at the test fixture input.

8.1.4.3 Limit

The spurious response immunity for messages shall not be less than 40 dB.

8.1.5 Blocking immunity or desensitization for digital messages

8.1.5.1 Definition

The blocking immunity or desensitization for messages is a measure of the capability of the receiver to receive a wanted modulated signal at the nominal frequency without exceeding a given degradation due to the presence of an unwanted unmodulated high level input signal, which is not a direct spurious frequency of the receiver under test.

It is specified as the ratio in dB of the level of the unwanted signal to a specified level of the wanted signal at the receiver input for which the message acceptance rate is 80 %.

8.1.5.2 Method of measurement

The test arrangement shown in figure 6 shall be used with the following test method:

- a) two signal generators A and B shall be connected to the test fixture input via a combining network. The wanted signal, represented by signal generator A, shall be at the nominal frequency of the receiver and shall have test modulation D-M3. The signal level of generator A shall be 3 dB above the level of the limit of the measured reference sensitivity for messages (see subclause 8.1.1.2);
- b) the wanted signal shall then be transmitted repeatedly and signal generator B shall be switched on. The unwanted signal shall be unmodulated and its frequency shall be selected in the range $+1 \text{ MHz} \pm 10 \%$ relative to the nominal frequency of the receiver. The frequency chosen shall be one at which no spurious response occurs. This level shall be adjusted until a message acceptance rate of less than 10 % is obtained;
- c) the level of the unwanted signal shall be reduced by 2 dB for each occasion that a successful response is not observed. The procedure shall be continued until three consecutive successful responses are observed. The level of the unwanted signal shall then be recorded;
- d) the unwanted input signal shall then be increased by 1 dB and the new value recorded. The measurement shall then be continuously repeated. In each case a response is not obtained the level of the unwanted signal shall be reduced by 1 dB and the new value recorded. If a successful response is obtained, the level of the unwanted signal shall not be changed until three consecutive successful responses have been obtained. In this case the unwanted signals shall be increased by 1 dB and the new value recorded. No levels of the unwanted signal shall be recorded unless preceded by a change in level. The measurement shall be stopped after 10 values have been recorded;
- e) the measurements shall be repeated at a frequency of the unwanted signal selected in the range $-1,0 \text{ MHz} \pm 10 \%$ relative to the nominal frequency of the receiver;
- f) the blocking level for messages is recorded as the lower value of the ratios in dB, of the two measurements above, of the average of the levels of the unwanted signal recorded in steps c) and d) to the level of the wanted signal.

8.1.5.3 Limit

The blocking immunity shall not be less than 56 dB.

8.1.6 Intermodulation immunity for digital messages

8.1.6.1 Definition

The intermodulation immunity for messages is a measure of the capability of the receiver to receive a wanted signal at the nominal frequency without exceeding a given degradation due to the presence of two or more unwanted signals with a special frequency relationship to the wanted signal frequency.

It is specified as the ratio in dB of the common level of the two unwanted signals to a specified level of the wanted signal, at the receiver input, for which the message acceptance rate is 80 %.

8.1.6.2 Method of measurement

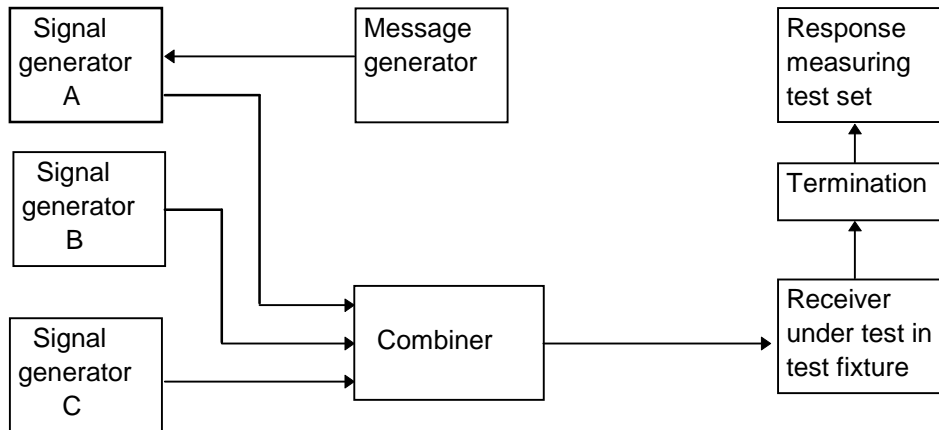

Figure 7: Measuring arrangement

The method of measurement shall be as follows:

- a) three signal generators, A, B and C, shall be connected to the test fixture input via a combining network. The wanted signal, represented by generator A, shall be at the nominal frequency and modulated by the test signal D-M3 (subclause 6.1.2).

The signal level of generator A shall be 3 dB above the measured sensitivity level for messages;

- b) the unwanted signal, represented by generator B, shall be unmodulated and adjusted to the frequency 50 kHz above the nominal frequency. The second unwanted signal, modulated by the test signal D-M3 (subclause 6.1.1) and represented by signal generator C, shall be adjusted to a frequency 100 kHz above the nominal frequency;
- c) the wanted signal shall then be transmitted repeatedly and signal generators B and C shall be switched on. The output levels of the two signal generators shall be maintained equal and adjusted to a value such that a message acceptance rate of less than 10 % is obtained;
- d) the levels of the unwanted signals shall be reduced by 2 dB for each occasion that a successful response is not observed. The procedure shall be continued until three consecutive successful responses are observed. The level of the unwanted signal shall then be recorded;
- e) the unwanted input signals shall then be increased by 1 dB and the new value recorded. The measurement shall then be continuously repeated. In each case a response is not obtained the level of the unwanted signal shall be reduced by 1 dB and the new value recorded. If a successful response is obtained, the level of the unwanted signal shall not be changed until three consecutive successful responses have been obtained. In this case the unwanted signals shall be increased by 1 dB and the new value recorded. No levels of the unwanted signal shall be recorded unless preceded by a change in level. The measurement shall be stopped after 10 values have been recorded;
- f) the intermodulation immunity for messages shall be recorded as the ratio in dB of the average of the levels of the unwanted signals recorded in steps d) and e) to the level of the wanted signal;
- g) the measurements shall be repeated with the unwanted signal (generator B) at a frequency 50 kHz below that of the wanted signal and the frequency of the unwanted modulated signal (generator C) at a frequency 100 kHz below that of the wanted signal.

8.1.6.3 Limit

The intermodulation immunity shall not be less than 42 dB.

8.1.7 Spurious emissions

8.1.7.1 Definition

Spurious emissions are discrete radio frequency signals radiated by the receiver.

They are specified as the power level of any discrete signal measured by the measuring device within the specified frequency range.

8.1.7.2 Method of measurements

On a test site, fulfilling the requirements of subclause 6.4, the sample shall be placed at the specified height on the support. The receiver shall be switched on.

The radiation of any spurious components shall be detected by the test antenna and receiver over the frequency range of 25 MHz - 4 GHz.

At each frequency at which a component is detected, the sample shall be rotated to obtain the maximum response and the effective radiated power of that component determined by a substitution measurement.

The measurements shall be repeated with the test antenna in the orthogonal plane.

8.1.7.3 Limits

The power of any spurious component shall not exceed:

- 2 nW in the range 100 kHz - 1 GHz; and
- 20 nW in the range 1 GHz - 4 GHz.

8.2 Base station receivers

8.2.1 Measured sensitivity for digital messages

8.2.1.1 Definition

The measured sensitivity for messages of the receiver is the minimum level of signal at the nominal frequency of the receiver which produces, after demodulation, a message acceptance rate of 80 %.

8.2.1.2 Method of measurement

The following method of measurement shall be used:

- a) a signal generator shall be connected to the receiver input. The signal generator shall be at the nominal frequency and modulated with the test signal D-M3 (subclause 6.1.2);
- b) the level of the signal generator shall be adjusted until a message acceptance rate of less than 10 % is obtained;
- c) the test signal shall be transmitted repeatedly whilst observing in each case whether or not a successful response is obtained. The test level shall be increased by 2 dB for each occasion that a successful response is not obtained. The procedure shall be continued until three consecutive successful responses are observed. The level of the test signal shall be recorded;
- d) the test signal level shall be reduced by 1 dB and the new value recorded. The measurement shall then be continuously repeated. In each case, if a response is not obtained, the test level shall be increased by 1 dB and the new value recorded. If a successful response is obtained, the test level shall not be changed until three consecutive successful responses have been observed. In this case the test level shall be reduced by 1 dB and the new value recorded. No test signal levels shall be recorded unless preceded by a change in level. The measurement shall be stopped after 10 values have been recorded;

- e) the measured sensitivity for messages is the average of the values recorded in steps c) and d). This value shall be recorded;
- f) the measurement shall be repeated under extreme test conditions.

8.2.1.3 Limits

The measured sensitivity value shall not exceed +6 dB μ V emf under normal test conditions, and +12 dB μ V emf under extreme test conditions.

8.2.2 Co-channel rejection for digital messages

8.2.2.1 Definition

The co-channel rejection for messages is a measure of the capability of the receiver to receive a wanted modulated signal at the nominal frequency without exceeding a given degradation due to the presence of an unwanted modulated signal, also at the nominal frequency.

It is specified as the ratio in dB of the level of the unwanted signal to the specified wanted signal level at the receiver input, for which the message acceptance rate is 80 %.

8.2.2.2 Method of measurement

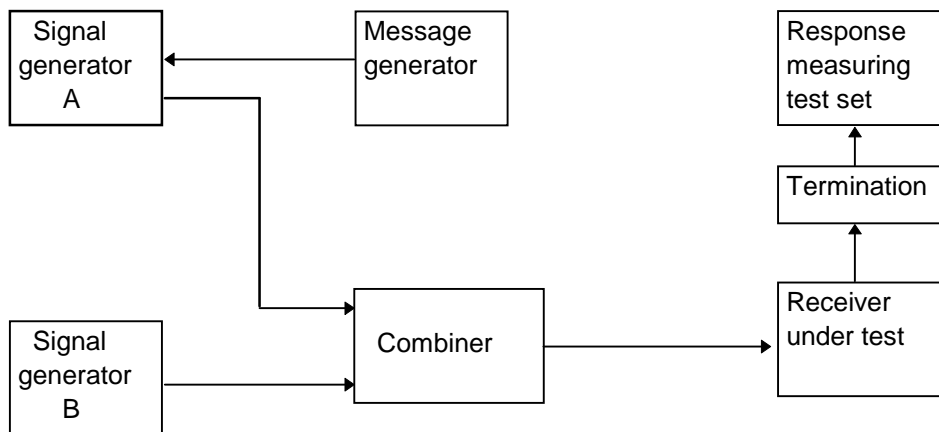

Figure 8: Measuring arrangement

The method of measurement shall be as follows:

- a) two signal generators, A and B, shall be connected to the receiver input via a combining network. The wanted signal, represented by generator A, shall be at the nominal frequency and modulated with test signal D-M3 (subclause 6.1.2). The signal level of generator A shall be +12 dB μ V emf under normal test conditions;
- b) the unwanted signal, represented by generator B, shall also be at the nominal frequency and modulated with the test signal D-M3 (subclause 6.1.1) and the level adjusted until a message acceptance rate of less than 10 % is obtained;
- c) the level of the unwanted signal shall be reduced by 2 dB for each occasion that a successful response is not observed. The procedure shall be continued until three consecutive successful responses are observed. The level of the unwanted signal shall then be recorded;
- d) the unwanted test signal shall then be increased by 1 dB and the new value recorded. The measurement shall then be continuously repeated. In each case if a response is not obtained the level of the unwanted signal shall be reduced by 1 dB and the new value recorded. If a successful response is obtained, the level of the unwanted signal shall not be changed until three consecutive responses have been obtained. In this case the unwanted signal shall be increased by 1 dB and the new value recorded. No levels of the unwanted signal shall be recorded unless preceded by a change in level. The measurement shall be stopped after 10 values have been recorded;

- e) the co-channel rejection ratio for messages shall be recorded as the ratio in dB of the average of the levels of the unwanted signal recorded in steps c) and d) to the level of the wanted signal, at the receiver input.

8.2.2.3 Limits

The co-channel rejection ratio shall be between:

- -8 dB and 0 dB for a channel spacing of 20 kHz and 25 kHz;
- -12 dB and 0 dB for a channel spacing of 10 kHz and 12,5 kHz.

8.2.3 Adjacent channel selectivity for digital messages

8.2.3.1 Definition

The adjacent channel selectivity for messages is a measure of the capability of the receiver to receive a wanted modulated signal at the nominal frequency without exceeding a given degradation due to the presence of an unwanted modulated signal which differs in frequency from the wanted signal by an amount equal to the adjacent channel spacing for which the equipment is intended.

It is specified as the lower value of the ratios in dB for the upper and lower adjacent channels of the level of the unwanted signal to a specified level of the wanted signal, for which the message acceptance rate is 80 %.

8.2.3.2 Method of measurement

The test arrangement shown in figure 8 shall be used with the following test method:

- a) two signal generators, A and B, shall be connected to the receiver input via a combining network. The wanted signal, represented by generator A, shall be at the nominal frequency and modulated with the test signal D-M3 (subclause 6.1.2). The signal level of generator A shall be +12 dB μ V emf under normal test conditions and +18 dB μ V emf under extreme test conditions;
- b) the unwanted signal, modulated by the test signal D-M3 (subclause 6.1.1) and represented by generator B, shall be at the channel frequency immediately above that of the wanted signal. The level of generator B shall be adjusted until a message acceptance rate of less than 10 % is obtained;
- c) the level of the unwanted signal shall be reduced by 2 dB for each occasion that a successful response is not observed. The procedure shall be continued until three consecutive successful responses are observed. The level of the unwanted signal shall then be recorded;
- d) the unwanted input signal shall then be increased by 1 dB and the new value recorded. The measurement shall then be continuously repeated. In each case a response is not obtained the level of the unwanted signal shall be reduced by 1 dB and the new value recorded. If a successful response is obtained, the level of the unwanted signal shall not be changed until three consecutive successful responses have been obtained. In this case the unwanted signal shall be increased by 1 dB and the new value recorded. No levels of the unwanted signal shall be recorded unless preceded by a change in level. The measurement shall be stopped after 10 values have been recorded;
- e) the measurement shall be repeated with the unwanted signal at the frequency of the channel below that of the wanted signal;
- f) the adjacent channel selectivity for messages shall be recorded for the upper and lower adjacent channels as the ratio of the average of the levels of the wanted signal, recorded in steps c) and d), to the level of the wanted signal.

8.2.3.3 Limits

The lower value of the adjacent channel selectivity of the upper and lower adjacent channels for the respective channel spacing shall not be less than the value given in table 7.

Table 7

Conditions	Channel spacing	
	10/12,5 kHz	20/25 kHz
normal	60 dB	70 dB
extreme	50 dB	60 dB

8.2.4 Spurious response immunity for digital messages

8.2.4.1 Definition

The spurious response immunity for messages is a measure of the capability of the receiver to receive a wanted signal at the nominal frequency without exceeding a given degradation due to the presence of an unwanted modulated signal at any other frequency, that differs from the wanted signal by more than one channel spacing, and at which a response is obtained.

It is specified as the value of the ratios in dB of the level of the unwanted signal to a specified level of the wanted signal, for which the message acceptance rate is 80 %.

8.2.4.2 Method of measurement

The test arrangement shown in figure 8 shall be used with the following test method:

- a) two signal generators, A and B, shall be connected to the receiver input via a combining network. The wanted signal, represented by generator A, shall be at the nominal frequency and modulated with the test signal D-M3 (subclause 6.1.2). The signal level of generator A shall be adjusted to +12 dB μ V emf, measured at the receiver input;
- b) the frequency of the unwanted signal, modulated by the test signal D-M3 (subclause 6.1.1) and represented by generator B, shall be adjusted to a frequency within the specified frequency range at which it is calculated according to annex D that a spurious response could occur. The level of the unwanted modulated signal shall be adjusted until a message acceptance rate of less than 10 % is obtained;
- c) the level of the unwanted signal shall be reduced by 2 dB for each occasion that a successful response is not observed. The procedure shall be continued until three consecutive successful responses are observed. The level of the unwanted signal shall then be recorded;
- d) the unwanted input signal shall then be increased by 1 dB and the new value recorded. The measurement shall then be continuously repeated. In each case a successful response is not obtained the level of the unwanted signal shall be reduced by 1 dB and the new value recorded. If a successful response is obtained, the level of the unwanted signal shall not be changed until three consecutive successful responses have been obtained. In this case the unwanted signal shall be increased by 1 dB and the new value recorded. No levels of the unwanted signal shall be recorded unless preceded by a change in level. The measurement shall be stopped after 10 values have been recorded;
- e) the measurement shall be repeated at each frequency within the specified frequency range at which it is calculated that a spurious response could occur;
- f) the spurious response immunity for messages shall be recorded for the frequency concerned as the ratio in dB of the average of the levels of the unwanted signal recorded in steps c) and d) to the level of the wanted signal at the receiver input.

8.2.4.3 Limit

The spurious response immunity for messages shall not be less than 70 dB.

8.2.5 Blocking immunity or desensitization for digital messages

8.2.5.1 Definition

The blocking immunity or desensitization for messages is a measure of the capability of the receiver to receive a wanted modulated signal at the nominal frequency without exceeding a given degradation due to the presence of an unwanted unmodulated high level input signal, which is not a direct spurious frequency of the receiver under test.

It is specified as the ratio in dB of the level of the unwanted signal to a specified level of the wanted signal at the receiver input for which the message acceptance rate is 80 %.

8.2.5.2 Method of measurement

The test arrangement shown in figure 8 shall be used with the following test method:

- a) two signal generators A and B shall be connected to the receiver input via a combining network. The wanted signal, represented by signal generator A, shall be at the nominal frequency of the receiver and shall have test modulation D-M3. The signal level of generator A shall be 3 dB above the level of the limit of the measured sensitivity for messages under normal test conditions;
- b) the wanted signal shall then be transmitted repeatedly and signal generator B shall be switched on. The unwanted signal shall be unmodulated and its frequency shall be selected in the range $+1 \text{ MHz} \pm 10 \%$ relative to the nominal frequency of the receiver. The frequency chosen shall be one at which no spurious response occurs. This level shall be adjusted until a message acceptance rate of less than 10 % is obtained;
- c) the level of the unwanted signal shall be reduced by 2 dB for each occasion that a successful response is not observed. The procedure shall be continued until three consecutive successful responses are observed. The level of the unwanted signal shall then be recorded;
- d) the unwanted input signal shall then be increased by 1 dB and the new value recorded. The measurement shall then be continuously repeated. In each case a response is not obtained the level of the unwanted signal shall be reduced by 1 dB and the new value recorded. If a successful response is obtained, the level of the unwanted signal shall not be changed until three consecutive successful responses have been obtained. In this case the unwanted signals shall be increased by 1 dB and the new value recorded. No levels of the unwanted signal shall be recorded unless preceded by a change in level. The measurement shall be stopped after 10 values have been recorded;
- e) the measurements shall be repeated at a frequency of the unwanted signal selected in the range $-1,0 \text{ MHz} \pm 10 \%$ relative to the nominal frequency of the receiver;
- f) the blocking level for messages is recorded as the lower value of the ratios in dB, of the two measurements above, of the average of the levels of the unwanted signal recorded in steps c) and d) to the level of the wanted signal.

8.2.5.3 Limit

The blocking immunity shall not be less than 70 dB.

8.2.6 Intermodulation immunity for digital messages

8.2.6.1 Definition

The intermodulation immunity for messages is a measure of the capability of the receiver to receive a wanted signal at the nominal frequency without exceeding a given degradation due to the presence of two or more unwanted signals with a special frequency relationship to the wanted signal frequency.

It is specified as the ratio in dB of the common level of the two unwanted signals to a specified level of the wanted signal, at the receiver input, for which the message acceptance rate ratio is 80 %.

8.2.6.2 Method of measurement

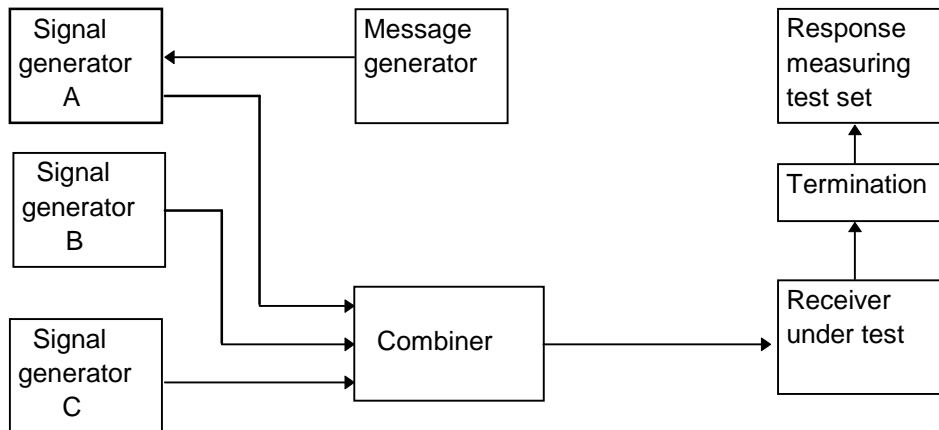

Figure 9: Measuring arrangement

The following method of measurement shall be used:

- a) three signal generators, A, B and C, shall be connected to the receiver input via a combining network. The wanted signal, represented by generator A, shall be at the nominal frequency and modulated by the test signal D-M3 (subclause 6.1.2). The signal level of generator A shall be +12 dB μ V emf;
- b) the unwanted signal, represented by generator B, shall be unmodulated and adjusted to the frequency 50 kHz above the nominal frequency. The second unwanted signal, modulated by the test signal D-M3 (subclause 6.1.1) and represented by signal generator C, shall be adjusted to a frequency 100 kHz above the nominal frequency;
- c) the wanted signal shall then be transmitted repeatedly and signal generators B and C shall be switched on. The output levels of the two signal generators shall be maintained equal and adjusted to a value such that a message acceptance rate of less than 10 % is obtained;
- d) the levels of the unwanted signals shall be reduced by 2 dB for each occasion that a successful response is not observed. The procedure shall be continued until three consecutive successful responses are observed. The level of the unwanted signals shall then be recorded;
- e) the unwanted input signals shall then be increased by 1 dB and the new value recorded. The measurement shall then be continuously repeated. In each case a response is not obtained the level of the unwanted signal shall be reduced by 1 dB and the new value recorded. If a successful response is obtained, the level of the unwanted signal shall not be changed until three consecutive successful responses have been obtained. In this case the unwanted signals shall be increased by 1 dB and the new value recorded. No levels of the unwanted signal shall be recorded unless preceded by a change in level. The measurement shall be stopped after 10 values have been recorded;
- f) the intermodulation immunity for messages shall be recorded as the ratio in dB of the average of the levels of the unwanted signals recorded in steps d) and e) to the level of the wanted signal;
- g) the measurements shall be repeated with the unwanted signal (generator B) at a frequency 50 kHz below that of the wanted signal and the frequency of the unwanted modulated signal (generator C) at a frequency 100 kHz below that of the wanted signal.

8.2.6.3 Limit

The intermodulation immunity shall not be less than 60 dB.

8.2.7 Spurious emissions

8.2.7.1 Definition

Spurious emissions are discrete radio frequency signals conveyed from the antenna socket by conduction or radiated by the receiver enclosure.

They are specified as the power level of any discrete signal measured by the measuring device within the specified frequency range.

8.2.7.2 Method of measurement

8.2.7.2.1 Conducted spurious components

The receiver input terminals shall be connected to a measuring receiver having an input impedance of 50 Ω and the receiver under test shall be switched on.

The frequency of the measuring receiver shall be adjusted over the specified frequency range of 9 kHz to 4 GHz. The frequency and the absolute power level of each of the spurious components detected shall be recorded.

The measuring receiver used shall have sufficient dynamic range and sensitivity to achieve the required measurement uncertainty at the specified limit.

8.2.7.2.2 Radiated spurious components

On a test site, fulfilling the requirements of subclause 6.4, the sample shall be placed at the specified height on the support. The receiver shall be switched on.

The radiation of any spurious components shall be detected by the test antenna and receiver over the frequency range of 25 MHz - 4 GHz.

At each frequency at which a component is detected, the sample shall be rotated to obtain the maximum response and the effective radiated power of that component determined by a substitution measurement.

The measurements shall be repeated with the test antenna in the orthogonal plane.

8.2.7.3 Limits

The power of any spurious component shall not exceed:

- 2 nW in the range 9 kHz - 1 GHz; and
- 20 nW in the range 1 GHz - 4 GHz.

9 Measurement uncertainty

9.1 Absolute measurement uncertainties: maximum values

The accumulated measurement uncertainties of the test system in use for the parameters to be measured should not exceed those given table 8. This is in order to insure that the measurements remain within an acceptable standard.

Table 8

Parameter	Uncertainty
RF frequency	$\pm 1 \times 10^{-7}$
RF power, conducted	$\pm 0,75$ dB
Maximum frequency deviation	
within 300 Hz and 6 kHz of audio frequency	± 5 %
within 6 kHz and 25 kHz of audio frequency	± 3 dB
Adjacent channel power	± 3 dB
Conducted emission of transmitters, valid up to 12,75 GHz	± 4 dB
Conducted emission of receivers	± 3 dB
Radiated emission of transmitter, valid up to 4 GHz	± 6 dB
Radiated emission of receiver, valid up to 4 GHz	± 6 dB
Temperature	$\pm 1^{\circ}\text{C}$
Humidity	± 5 %

For the test methods according to this ETS the uncertainty figures are valid to a confidence level of 95 %, calculated according to the methods described in ETR 028 [2].

Annex A (normative): Radiated measurements

A.1 Test sites and general arrangements for measurements involving the use of radiated fields

A.1.1 Open air test site

The open air test site (see subclause 6.1) shall be on a reasonably level surface or ground. At one point on the site, a ground plane of at least 5 m diameter shall be provided. In the middle of this ground plane, a non-conducting support, capable of rotation through 360° in the horizontal plane, shall be used to support the test sample in its standard position, at 1,5 m above the ground plane. The test site shall be large enough to allow the erection of a measuring or transmitting antenna at a distance of $\lambda/2$ or 3 m whichever is the greater. The distance actually used shall be recorded with the results of the tests carried out on the site.

Sufficient precautions shall be taken to ensure that reflections from extraneous objects adjacent to the site do not degrade the measurements results.

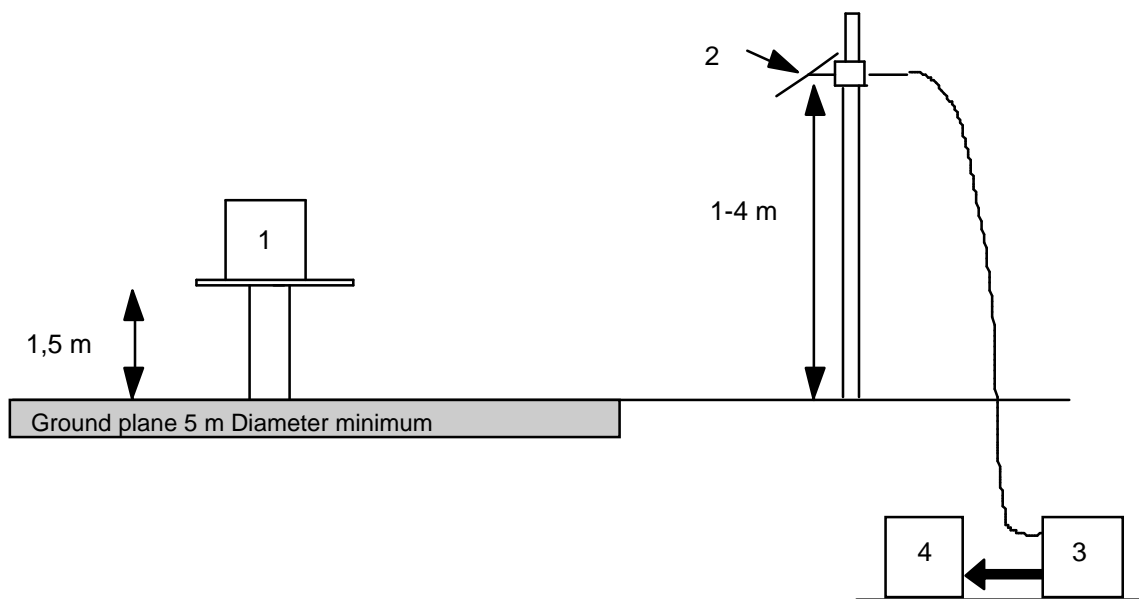

- NOTE:
- 1) Equipment under test
 - 2) Test antenna
 - 3) High pass filter (may be necessary)
 - 4) Spectrum analyser or measuring receiver

Figure A.1: Open Air test site

A.1.1.1 Standard position

The standard position on all test sites, except for equipment which is intended to be worn on a person, shall be as follows:

- for equipment with an integral antenna; it shall be placed in the position closest to normal use as declared by the manufacturer;
- for equipment with a rigid external antenna; the antenna shall be vertical;
- for equipment with non-rigid external antenna, the antenna shall be extended vertically upwards by a non-conducting support.

A.1.2 Test antenna

The test antenna is used to detect the radiation from both the test sample and the substitution antenna, when the site is used for radiation measurements. Where necessary, it is used as a transmitting antenna, when the site is used for the measurement of receiver characteristics.

This antenna is mounted on a support such as to allow the antenna to be used in either horizontal or vertical polarization and for the height of its centre above ground to be varied over the range 1 m to 4 m. Preferably a test antenna with pronounced directivity should be used. The size of the test antenna along the measurement axis shall not exceed 20 % of the measuring distance.

For receiver and transmitter radiation measurements, the test antenna is connected to a measuring receiver, capable of being tuned to any frequency under investigation and of measuring accurately the relative levels of signals at its input. For receiver radiated sensitivity measurements the test antenna is connected to a signal generator.

A.1.3 Substitution antenna

When measuring in the frequency range up to 1 GHz the substitution antenna shall be a $\lambda/2$ dipole, resonant at the operating frequency, or a shortened dipole, calibrated to the $\lambda/2$ dipole. When measuring in the frequency range above 4 GHz a horn radiator shall be used. For measurements between 1 GHz and 4 GHz either a $\lambda/2$ dipole or a horn radiator may be used. The centre of this antenna shall coincide with the reference point of the test sample it has replaced. This reference point shall be the volume centre of the sample when its antenna is mounted inside the cabinet, or the point where an external antenna is connected to the cabinet.

The distance between the lower extremity of the dipole and the ground shall not be less than 0,3 m.

The substitution antenna shall be connected to a calibrated signal generator when the site is used for spurious radiation measurements and transmitter effective radiated power measurements. The substitution antenna shall be connected to a calibrated measuring receiver when the site is used for the measurement of receiver sensitivity.

The signal generator and the receiver shall operate at the frequencies under investigation and shall be connected to the antenna through suitable matching and balancing networks.

NOTE: The gain of a horn antenna is generally expressed relative to an isotropic radiator.

A.1.4 Optional additional indoor site

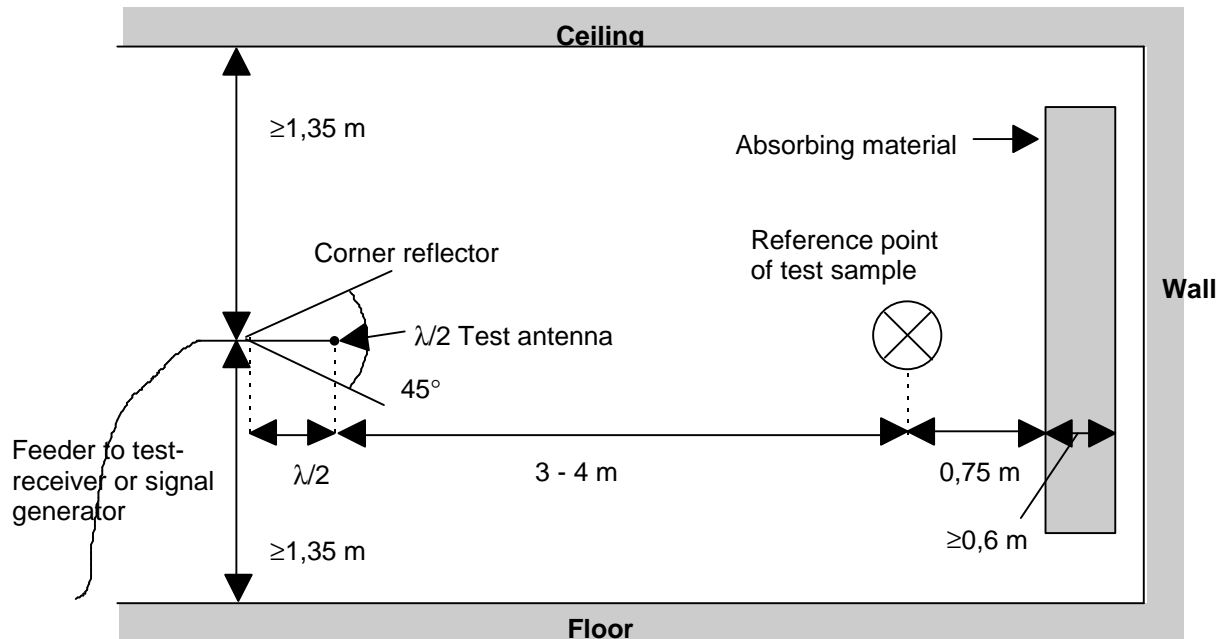

Figure A.2: Indoor test site arrangement (shown horizontal polarization)

When the frequency of the signals being measured is greater than 80 MHz, use may be made of an indoor test site. If this alternative site is used, this shall be recorded in the test report.

The measurement site may be a laboratory room with a minimum area of 6 m by 7 m and at least 2,7 m in height.

Apart from the measuring apparatus and the operator, the room shall be as free as possible from reflecting objects other than the walls, floor and ceiling.

The potential reflections from the wall behind the equipment under test are reduced by placing a barrier of absorbent material in front of it. The corner reflector around the test antenna is used to reduce the effect of reflections from the opposite wall and from the floor and ceiling, in the case of horizontally polarized measurements. Similarly, the corner reflector reduces the effects of reflections from the side walls for vertically polarized measurements. For the lower part of the frequency range (below approximately 175 MHz) no corner reflector or absorbent barrier is needed. For practical reasons, the $\lambda/2$ antenna in figure A.2 may be replaced by an antenna of constant length, provided that this length is between $\lambda/4$ and λ at the frequency of measurement, and the sensitivity of the measuring system is sufficient. In the same way the distance of $\lambda/2$ to the apex may be varied.

The test antenna, measuring receiver, substitution antenna and calibrated signal generator are used in a way similar to that of the general method. To ensure that errors are not caused by the propagation path approaching the point at which phase cancellation between the direct and the remaining reflected signals occurs, the substitution antenna shall be moved through a distance of $\pm 0,1$ m in the direction of the test antenna as well as in the two directions perpendicular to this first direction.

If these changes of distance cause a signal change of greater than 2 dB, the test sample should be re-sited until a change of less than 2 dB is obtained.

A.2 Guidance on the use of radiation test sites

For measurements involving the use of radiated fields, use may be made of a test site in conformity with the requirements of clause A.1 of this annex. When using such a test site, the following conditions should be observed to ensure consistency of measuring results.

A.2.1 Measuring distance

Evidence indicates that the measuring distance is not critical and does not significantly affect the measuring results, provided that the distance is not less than $\lambda/2$ at the frequency of measurement, and that the precautions described in this annex are observed. Measuring distances of 3 m, 5 m, 10 m and 30 m are in common use in European test laboratories.

A.2.2 Test antenna

Different types of test antenna may be used, since performing substitution measurements reduces the effect of the errors on the measuring results.

Height variation of the test antenna over a range of 1 m to 4 m is essential in order to find the point at which the radiation is a maximum.

Height variation of the test antenna may not be necessary at the lower frequencies below approximately 100 MHz.

A.2.3 Substitution antenna

Variations in the measuring results may occur with the use of different types of substitution antenna at the lower frequencies below approximately 80 MHz. Where a shortened dipole antenna is used at these frequencies, details of the type of antenna used should be included with the results of the tests carried out on the test site. Correction factors shall be taken into account when shortened dipole antennas are used.

A.2.4 Artificial antenna

The dimensions of the artificial antenna used during radiated measurements should be small in relation to the sample under test.

Where possible, a direct connection should be used between the artificial antenna and the test sample. In cases where it is necessary to use a connecting cable, precautions should be taken to reduce the radiation from this cable by, for example, the use of ferrite cores or double screened cables.

A.2.5 Auxiliary cables

The position of auxiliary cables (power supply and microphone cables etc.) which are not adequately decoupled, may cause variations in the measurement results. In order to get reproducible results, cables and wires of auxiliaries should be arranged vertically downwards (through a hole in the non-conducting support).

A.3 Further optional alternative indoor test site using an anechoic chamber

For radiation measurements, when test frequency of the signals being measured is greater than 25 MHz, use may be made of an indoor test site being a well-shielded anechoic chamber simulating a free space environment. If such a chamber is used, this shall be recorded in the test report.

The test antenna, measuring receiver, substitution antenna and calibrated signal generator are used in a way similar to that of the general method, clause A.1. In the range 25 MHz to 100 MHz, some additional calibration may be necessary.

An example of a typical measurement site may be an electrically shielded anechoic chamber being 10 m long, 5 m broad and 5 m high. Walls and ceiling should be coated with RF absorbers of 1 m height. The base should be covered with absorbing material 1 m thick, and a wooden floor, able to carry test equipment and operators. A measuring distance of 3 m to 5 m in the long middle axis of the chamber can be used for measurements up to 12,75 GHz. The construction of the anechoic chamber is described in the following clauses.

A.3.1 Example of the construction of a shielded anechoic chamber

Free-field measurements can be simulated in a shielded measuring chamber where the walls are coated with RF absorbers. Figure A.3 shows the requirements for shielding loss and wall return loss of such a room. As dimensions and characteristics of usual absorber materials are critical below 100 MHz (height of absorbers < 1 m, reflection attenuation < 20 dB) such a room is more suitable for measurements above 100 MHz. Figure A.4 shows the construction of an anechoic shielded measuring chamber having a base area of 5 m by 10 m and a height of 5 m.

Ceilings and walls are coated with pyramidal formed RF absorbers approximately 1 m high. The base is covered with absorbers which form a non-conducting sub-floor, or with special ground floor absorbers. The available internal dimensions of the room are 3 m × 8 m × 3 m, so that a maximum measuring distance of 5 m length in the middle axis of this room is available.

At 100 MHz the measuring distance can be extended up to a maximum of 2λ .

The floor absorbers reduce floor reflections so that the antenna height need not be changed and floor reflection influences need not be considered.

All measuring results can, therefore, be checked with simple calculations and the measurement uncertainties have the smallest possible values due to the simple measuring configuration.

A.3.2 Influence of parasitic reflections in anechoic chambers

For free-space propagation in the far field condition the correlation $E = E_0 \times (R_0/R)$ is valid for the dependence of the field strength E on the distance R , whereby E_0 is the reference field strength in the reference distance R_0 .

It is useful to use this correlation for comparison measurements, as all constants are eliminated with the ratio and neither cable attenuation, nor antenna mismatch, or antenna dimensions are of importance.

Deviations from the ideal curve can be seen easily if the logarithm of the above equation is used, because the ideal correlation of field strength and distance can then be shown as a straight line and the deviations occurring in practice are clearly visible. This indirect method shows the disturbances due to reflections more readily and is far less problematical than the direct measurement of reflection attenuation.

With an anechoic chamber of the dimensions suggested in clause A.3 at low frequencies up to 100 MHz, there are no far field conditions and therefore reflections are stronger so that careful calibration is necessary. In the medium frequency range from 100 MHz to 1 GHz the dependence of the field strength on the distance meets the expectations very well. In the frequency range of 1 GHz to 12,75 GHz, because more reflections will occur, the dependence of the field strength on the distance will not correlate so closely.

A.3.3 Calibration of the shielded RF anechoic chamber

The calibration and mode of use is the same as for an open air test site, the only difference being that the test antenna does not need to be raised and lowered whilst searching for a maximum, which simplifies the method of measurement.

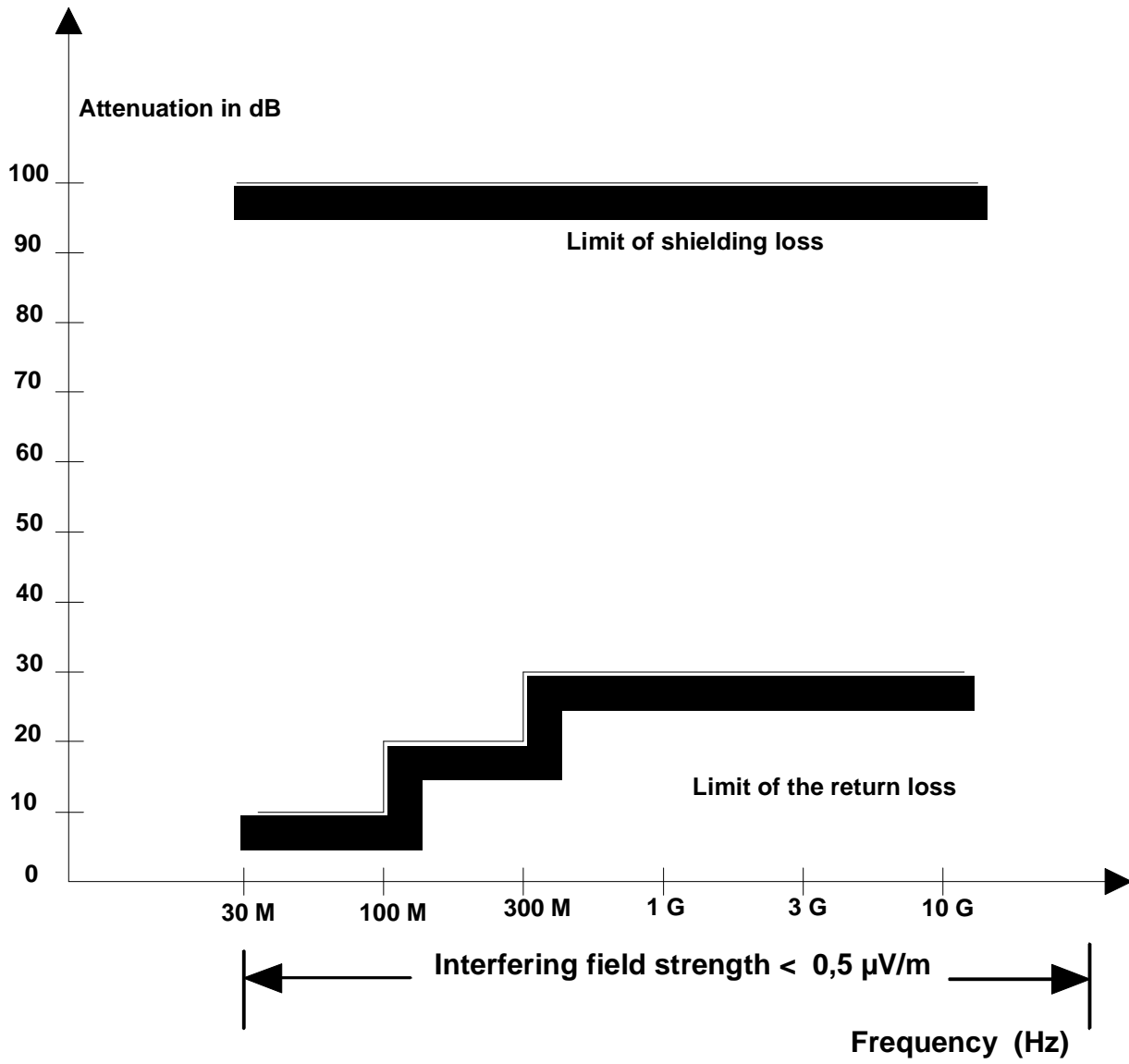

Figure A.3

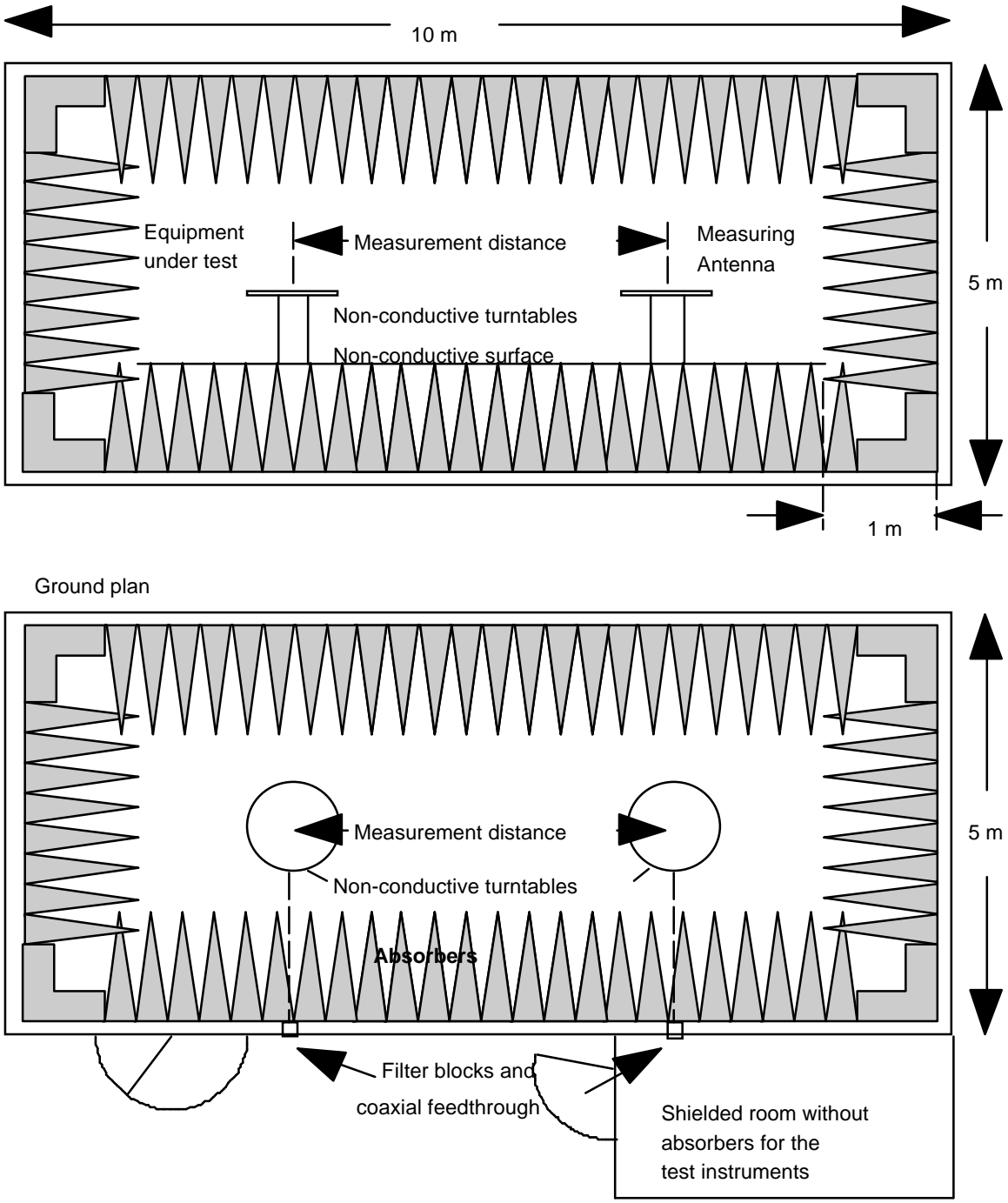

Figure A.4: Example of construction of an anechoic shielded chamber

Annex B (normative): Simulated man (support for pocket equipment)

The simulated (sometimes known as "salty") man comprises a rotatable acrylic tube filled with salt water placed on the ground.

The container shall have the dimensions shown in table B.1.

Table B.1

Height	$1,7 \pm 0,1$ m
Inside diameter	300 ± 5 mm
Side wall thickness	$5 \pm 0,5$ mm

The container shall be filled with a salt (NaCl) solution of 1,5 g per litre of distilled water.

Annex C (normative): Specification of power measuring receiver

The power measuring receiver consists of a mixer, an IF filter, an oscillator, an amplifier, a variable attenuator and a rms value indicator. Instead of the variable attenuator with the rms value indicator it is also possible to use a dB-calibrated rms voltmeter.

The technical characteristics of the power measuring receiver are given in the following clauses.

C.1 IF filter

The IF filter shall be within the limits of the selectivity characteristic given in figure C.1.

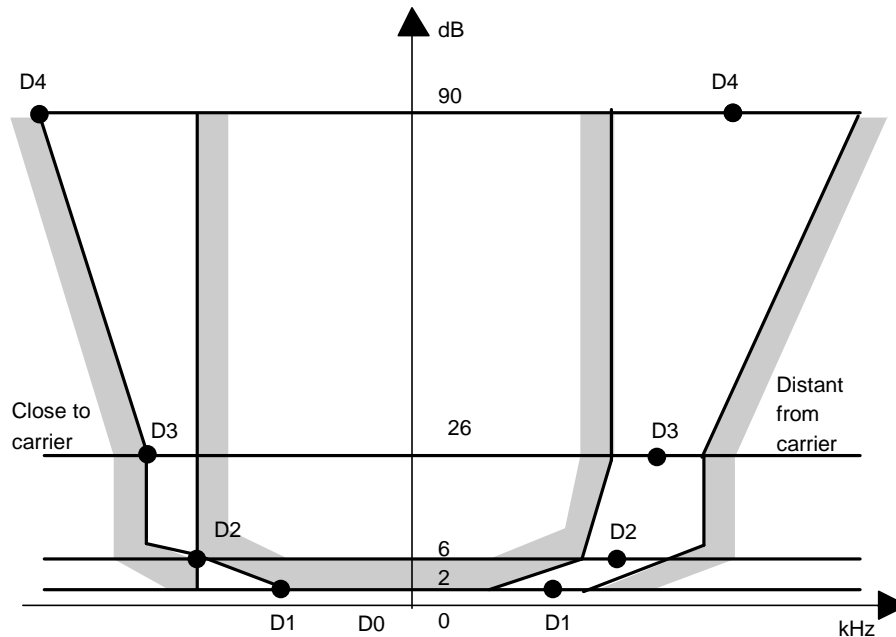

Figure C.1

The selectivity characteristic of the filter shall be defined by values of frequency separation given in table C.1.

Table C.1

Frequency separation of the filter curve from the nominal frequency of adjacent channel (kHz)				
Channel spacing	D1	D2	D3	D4
10/12,5 kHz	3,00	4,25	5,50	9,50
20 kHz	4,00	7,00	8,25	12,25
25 kHz	5,00	8,00	9,25	13,25

The attenuation points shall not exceed the tolerances given in tables C.1 and C.2.

Table C.2

Attenuation points close to carrier (kHz)				
Channel spacing	D1	D2	D3	D4
10/12,5 kHz	+1,35	±0,1	-1,35	-5,35
20 kHz	+3,10	±0,1	-1,35	-5,35
25 kHz	+3,10	±0,1	-1,35	-5,35

Table C.3

Attenuation points distant from carrier (kHz)				
Channel spacing	D1	D2	D3	D4
10/12,5 kHz	±2,0	±2,0	±2,0	+2,0/-6,0
20 kHz	±3,0	±3,0	±3,0	+3,0/-7,0
25 kHz	±3,5	±3,5	±3,5	+3,5/-7,5

The minimum attenuation of the filter outside the 90 dB attenuation points shall be ≥ 90 dB.

C.2 Attenuation indicator

The attenuation indicator shall have a minimum range of 80 dB and a reading accuracy of 1 dB.

C.3 RMS value indicator

The instrument shall accurately indicate non-sinusoidal signals in a ratio of up to 10:1 between peak value and rms value.

C.4 Oscillator and amplifier

The oscillator and the amplifier shall be designed in such a way that the measurement of the adjacent channel power of a low noise unmodulated transmitter, whose intrinsic [self] noise has a negligible influence on the measurement result, yields a measured value of ≤ 80 dB for 10 kHz and 12,5 kHz channel spacing ≤ 90 dB for 20 kHz and 25 kHz channel spacing, referred to the carrier of the oscillator.

Annex D (normative): Calculations of spurious responses frequencies

D.1 Introduction to the method

To determine the frequencies at which spurious responses may occur the following calculations shall be made:

- a) calculation of the "limited frequency range":
 - the limited frequency range is equal to the frequency of the local oscillator signal (f_{lo}) applied to the first mixer of the receiver \pm the sum of the intermediate frequencies (if_1, \dots, if_n) and half the switching range of the receiver ($sr/2$);
 - hence the limited frequency range = $f_{lo} \pm (if_1 + if_2 + \dots + if_n + sr/2)$;
- b) calculation of frequencies outside the limited frequency range:
 - a calculation of the frequencies at which spurious responses may occur outside the range determined in a) shall be made for the remaining frequency range of interest:
 - the frequencies outside the limited frequency range are equal to the harmonics of the frequency of the local oscillator signal (f_{lo}) applied to the 1st mixer of the receiver \pm the numeric value of the first intermediate frequency (if_1) of the receiver;
 - hence the frequencies of these spurious responses = $nf_{lo} \pm if_1$ where n is an integer greater than or equal to 2.

For the calculations a) and b) the manufacturer shall state the frequency of the receiver, the frequency of the local oscillator signal (f_{lo}) applied to the 1st mixer of the receiver, the intermediate frequencies (if_1, if_2 etc.) and the switching range of the receiver.

NOTE: The switching range of the receiver is defined as the maximum frequency range over which the receiver can be operated without re-alignment or re-programming.

Annex E (normative): Subclauses of this ETS relevant for compliance with the essential requirements of relevant EC Council Directives

Table E.1: Subclauses of this ETS dealing with transmitters and relevant for compliance with the essential requirements of EC Council directives

Clause/subclause number and title		Corresponding article of Council Directive 89/336/EEC	Qualifying remarks
7.4	Spurious emissions	4(a)	

Table E.2: Subclauses of this ETS dealing with pocket receivers and relevant for compliance with the essential requirements of EC Council directives

Clause/subclause number and title		Corresponding article of Council Directive 89/336/EEC	Qualifying remarks
8.1.4	Spurious response immunity for digital messages	4(b)	
8.1.5	Blocking immunity or desensitization for digital messages	4(b)	
8.1.7	Spurious emissions	4(a)	

Table E.3: Subclauses of this ETS dealing with base station receivers and relevant for compliance with the essential requirements of EC Council directives

Clause/subclause number and title		Corresponding article of Council Directive 89/336/EEC	Qualifying remarks
8.2.4	Spurious response immunity for digital messages	4(b)	
8.2.5	Blocking immunity or desensitization for digital messages	4(b)	
8.2.7	Spurious emissions	4(a)	

Annex F (informative): Private wide-area paging system basic services

The primary function of the system is to alert and/or to inform ambulant persons. The simplest and most well known paging receiver is a selective call receiver with an alerting device only. When paged the pocket receiver alerts the user in order to take some pre-determined action. Messages can be transferred to the user by additional transmission of data.

Private systems distinguish themselves from public wide area systems by features like absence control, interfacing to PABXs, interfacing to all kind of alerting equipment, computers, sensing devices etc. These features make private systems extremely suitable for tailoring to the requirements of the users organization, specially if fast responses to calls are needed (hospitals, alarm systems etc.). Being a private system the access is limited to one's own closed user group.

In order to improve the coverage within the range of the system, the use of multiple transmitters is envisaged. It is recommended however, that the output power of the base transmitter(s) is set to the lowest possible level that still produces a satisfactory coverage.

PWAP systems combine the interfacing flexibility and the cost advantage (traffic independent) of On-Site Paging (OSP) systems with the advantage of a larger range. Therefore PWAP systems lend themselves ideally as a cheap, versatile communication means for:

- emergency teams on stand-by at home or elsewhere;
- hospitals or manufacturing industry with various locations within a city;
- public utilities (energy, gas, water);
- maintenance, security and social services;
- small workshops and craftsmen with outdoor activities.

This large number of potential users for paging services can only be accommodated by a highly frequency-spectrum efficient system.

Annex G (informative): Bibliography

- CEPT Recommendation T/R 20-05: "Low power personal paging systems".
- ESPA publication 4.2.7: "Proposal for a standard for Private Extended Range paging".
- ETS 300 224: "Radio Equipment and Systems (RES); On-site paging service Technical and functional characteristics for on-site paging systems, including test methods".
- ETS 300 133-5: "Radio Equipment and Systems (RES); Enhanced Radio MESSage System (ERMES); Part 5: Receiver conformance specification".

History

Document history			
August 1996	Public Enquiry	PE 112:	1996-08-19 to 1996-12-13
April 1997	Vote	V 9724:	1997-04-15 to 1997-06-13