



**E**UROPEAN  
**T**ELECOMMUNICATION  
**S**TANDARD

**ETS 300 700**

March 1997

---

Source: ETSI EP DECT

Reference: DE/DECT-050069

ICS: 33.020

**Key words:** DECT, WRS

## **Digital Enhanced Cordless Telecommunications (DECT); Wireless Relay Station (WRS)**

**ETSI**

European Telecommunications Standards Institute

**ETSI Secretariat**

**Postal address:** F-06921 Sophia Antipolis CEDEX - FRANCE

**Office address:** 650 Route des Lucioles - Sophia Antipolis - Valbonne - FRANCE

**X.400:** c=fr, a=atlas, p=etsi, s=secretariat - **Internet:** secretariat@etsi.fr

Tel.: +33 4 92 94 42 00 - Fax: +33 4 93 65 47 16

---

**Copyright Notification:** No part may be reproduced except as authorized by written permission. The copyright and the foregoing restriction extend to reproduction in all media.

© European Telecommunications Standards Institute 1997. All rights reserved.



## Contents

Foreword .....	7
1 Scope .....	9
2 Normative references .....	9
3 Definitions and abbreviations .....	10
3.1 Definitions .....	10
3.2 Abbreviations .....	11
4 Wireless Relay Station (WRS) .....	12
4.1 Introduction .....	12
4.2 Description .....	12
4.2.1 PHL layer functions .....	13
4.2.2 MAC layer functions .....	13
4.2.3 Data Link Control (DLC) layer functions .....	13
4.2.4 NWK layer functions .....	13
4.2.4.1 Over-the-air maintenance .....	13
4.2.5 Identities .....	14
4.3 Services .....	14
4.4 Procedures .....	14
4.4.1 PHL layer .....	14
4.4.2 MAC layer .....	14
4.4.2.1 Extended fixed part capabilities .....	14
4.4.2.2 Hop control .....	14
5 Cordless Radio Fixed Part (CRFP) .....	15
5.1 Description .....	15
5.1.1 General .....	15
5.1.2 Reference model .....	15
5.1.3 MAC layer functions .....	15
5.1.3.1 General .....	15
5.1.3.2 Frame multiplexing structure .....	16
5.1.3.3 Logical channel mapping .....	17
5.1.3.4 Quality Control and Flow Control .....	17
5.1.4 NWK layer functions .....	17
5.1.5 Identities .....	18
5.1.5.1 Identities and addressing .....	18
5.1.5.2 Subscription data .....	18
5.2 Messages .....	18
5.2.1 MAC layer control .....	18
5.3 Procedures .....	19
5.3.1 MAC layer .....	19
5.3.1.1 Connection Oriented mode (C/O) procedures at CRFP .....	19
5.3.1.1.1 Creation of a Relay Multi Bearer Control (RMBC) .....	19
5.3.1.1.2 Normal C/O bearer set-up .....	19
5.3.1.1.3 Dual C/O bearer set-up .....	20
5.3.1.1.4 C/O connection release .....	21
5.3.1.1.5 C/O abnormal connection release .....	22
5.3.1.2 CRFP connection suspend and resume .....	24
5.3.1.3 C/O bearer handover .....	25
5.3.2 DLC layer .....	27
5.3.2.1 Connection handover .....	27
5.3.2.2 DLC variables .....	27
5.3.3 NWK layer .....	28
5.3.4 Security .....	29

	5.3.4.1	General .....	29
	5.3.4.2	CRFP initialization of PT cipher key .....	31
	5.3.5	Management .....	31
	5.3.5.1	CRFP MAC modes .....	31
	5.3.5.2	CRFP states and state transitions .....	31
5.4		Example operation of CRFP .....	32
	5.4.1	Introduction .....	32
	5.4.2	Example GAP procedures .....	32
6		Repeater Part (REP) .....	32
6.1		Description .....	32
	6.1.1	General .....	32
	6.1.2	Reference model .....	32
	6.1.3	MAC layer functions .....	33
	6.1.3.1	General .....	33
	6.1.3.2	Frame multiplexing .....	33
		6.1.3.2.1 Quality control .....	35
		6.1.3.2.2 Bearers selection .....	36
		6.1.3.2.3 Establishment of the double duplex bearer .....	36
		6.1.3.2.4 Double simplex bearers .....	36
	6.1.3.3	Logical channel mapping .....	36
	6.1.4	DLC functions .....	37
	6.1.5	NWK layer functions .....	37
	6.1.6	Management functions .....	38
	6.1.6.1	Identities and addressing .....	38
6.2		Definitions .....	38
6.3		Messages .....	38
6.3.1		MAC control (Mt) .....	38
6.4		Procedures .....	38
6.4.1		MAC layer .....	38
	6.4.1.1	C/O connection .....	38
		6.4.1.1.1 Physical set-up procedure .....	38
		6.4.1.1.2 Creation of a double duplex bearer .....	40
		6.4.1.1.3 Mapping procedure .....	40
	6.4.1.2	REP relayed C/O connection .....	41
		6.4.1.2.1 IWU .....	41
		6.4.1.2.2 REP relayed C/O single duplex bearer set-up .....	42
		6.4.1.2.3 REP relayed C/O bearer release .....	43
		6.4.1.2.4 REP relayed C/O bearer handover .....	43
6.4.2		DLC layer .....	44
	6.4.2.1	REP relayed C/O connection handover .....	44
6.4.3		Management .....	44
	6.4.3.1	REP states .....	44
	6.4.3.2	REP actions and states transitions .....	45
		6.4.3.2.1 Actions in the Idle_Unlocked and Active_Unlocked states .....	45
		6.4.3.2.2 Actions in the Locked state .....	45
		6.4.3.2.3 Entry into the Active_Idle state .....	45
		6.4.3.2.4 Actions in the Active_Idle state .....	46
		6.4.3.2.5 Entry into the Active_Traffic state .....	46
		6.4.3.2.6 Actions in the Active_Traffic state .....	46
	6.4.3.3	Channel selection .....	46
6.5		Example operation of REP .....	47
Annex A (normative):		The optional CRFP interface to REP .....	55
A.1		Description .....	55
	A.1.1	General .....	55
	A.1.2	Frame multiplexing structure .....	55
A.2		Messages .....	56

A.2.1	MAC layer .....	56
A.2.2	Hop control.....	56
A.3	Procedures .....	56
A.3.1	MAC layer .....	56
A.3.2	Channel selection .....	58
Annex B (normative):	ETS 300 175 changes.....	59
B.1	Modifications to MAC layer specification, ETS 300 175-3.....	59
B.1.1	Modifications to subclause 7.1.4.....	59
B.1.2	Modifications to subclause 7.2.3.4.2.....	60
B.1.3	Modifications to subclause 10.5.1.1.....	61
B.1.4	Modifications to subclause 10.5.1.2.1.....	61
B.1.5	Modifications to subclause 10.5.1.3.1.....	61
B.2	Modifications to NWK layer specification, ETS 300 175-5.....	61
B.2.1	Modifications to subclause 7.7.18.....	61
History.....		62

Blank page

## Foreword

This European Telecommunication Standard (ETS) has been produced by the Digital Enhanced Cordless Telecommunications (DECT) Project of the European Telecommunications Standards Institute (ETSI).

<b>Transposition dates</b>	
Date of adoption:	21 February 1997
Date of latest announcement of this ETS (doa):	30 June 1997
Date of latest publication of new National Standard or endorsement of this ETS (dop/e):	31 December 1997
Date of withdrawal of any conflicting National Standard (dow):	31 December 1997

Blank page



## 1 Scope

This European Telecommunication Standard (ETS) defines the Digital Enhanced Cordless Telecommunications (DECT) Wireless Relay Station (WRS). A WRS is an additional building block for the DECT fixed network.

This ETS defines provisions needed for a controlled and reliable application of the DECT WRS infrastructure building block. These provisions are not related to any specific profile.

## 2 Normative references

This ETS incorporates, by dated or undated reference, provisions from other publications. These normative references are cited at the appropriate places in the text and the publications are listed hereafter. For dated references, subsequent amendments to or revisions of any of these publications apply to this ETS only when incorporated in it by amendment or revision. For undated references the latest edition of the publication referred to applies.

- [1] ETS 300 175-1: "Radio Equipment and Systems (RES); Digital European Cordless Telecommunications (DECT); Common Interface (CI); Part 1: Overview".
- [2] ETS 300 175-2: "Radio Equipment and Systems (RES); Digital Enhanced Cordless Telecommunications (DECT); Common Interface (CI); Part 2: Physical layer (PHL)".
- [3] ETS 300 175-3: "Radio Equipment and Systems (RES); Digital European Cordless Telecommunications (DECT); Common Interface (CI); Part 3: Medium Access Control (MAC) layer".
- [4] ETS 300 175-4: "Radio Equipment and Systems (RES); Digital European Cordless Telecommunications (DECT); Common Interface (CI); Part 4: Data Link Control (DLC) layer".
- [5] ETS 300 175-5: "Radio Equipment and Systems (RES); Digital European Cordless Telecommunications (DECT); Common Interface (CI); Part 5: Network (NWK) layer".
- [6] ETS 300 175-6: "Radio Equipment and Systems (RES); Digital European Cordless Telecommunications (DECT); Common Interface (CI); Part 6: Identities and addressing".
- [7] ETS 300 175-7: "Radio Equipment and Systems (RES); Digital European Cordless Telecommunications (DECT); Common Interface (CI); Part 7: Security features".
- [8] ETS 300 175-8: "Radio Equipment and Systems (RES); Digital European Cordless Telecommunications (DECT); Common Interface (CI); Part 8: Speech coding and transmission".
- [9] ETR 043: "Radio Equipment and Systems (RES); Digital European Cordless Telecommunications (DECT); Common interface; Services and facilities requirements specification".
- [10] ETR 246: "Radio Equipment and Systems (RES); Digital European Cordless Telecommunications (DECT); Application of DECT Wireless Relay Station (WRS)".

### 3 Definitions and abbreviations

#### 3.1 Definitions

For the purposes of this ETS, the following definitions apply:

**Cordless Radio Fixed Part (CRFP):** A WRS that provides independent bearer control to a Portable radio Termination (PT) and Fixed radio Termination (FT) for relayed connections.

**Fixed Part (DECT Fixed Part) (FP):** A physical grouping that contains all of the elements in the DECT network between the local network and the DECT air interface.

NOTE 1: A DECT FP contains the logical elements of at least one FT, plus additional implementation specific elements.

**Fixed radio Termination (FT):** A logical group of functions that contains all of the DECT processes and procedures on the fixed side of the DECT air interface.

NOTE 2: A FT only includes elements that are defined in the DECT CI standard. This includes radio transmission elements together with a selection of layer 2 and layer 3 elements.

**Handover:** The process of switching a call in progress from one physical channel to another physical channel. These processes can be internal (see internal handover) or external (see external handover).

NOTE 3: There are two physical forms of handover, intra-cell handover and inter-cell handover. Intra-cell handover is always internal. Inter-cell handover can be internal or external.

**Inter Working Unit (IWU):** A unit that is used to interconnect sub networks.

NOTE 4: The IWU contains the inter-working functions necessary to support the required sub network inter-working.

**Medium Access Control (MAC) Connection (CONNECTION):** An association between one source MAC Multi-Bearer Control (MBC) entity and one destination MAC MBC entity. This provides a set of related MAC services (a set of logical channels), and it can involve one or more underlying MAC bearers.

**Portable Part (DECT Portable Part) (PP):** A physical grouping that contains all elements between the user and the DECT air interface. PP is a generic term that may describe one or several physical pieces.

NOTE 5: A DECT PP is logically divided into one PT plus one or more Portable Applications (PAs).

**Portable radio Termination (PT):** A logical group of functions that contains all of the DECT processes and procedures on the portable side of the DECT air interface.

NOTE 6: A PT only includes elements that are defined in the DECT CI standard. This includes radio transmission elements (layer 1) together with a selection of layer 2 and layer 3 elements.

**Radio Fixed Part (RFP):** One physical sub-group of a FP that contains all the radio end points (one or more) that are connected to a single system of antennas.

**Repeater Part (REP):** A WRS which relay the information within the half frame time interval.

**Wireless Relay Station (WRS):** A physical grouping that combines elements of both PTs and FTs to relay information on a physical channel from one DECT termination to a physical channel for another DECT termination.

NOTE 7: The DECT termination can be a PT or an FT or another WRS.

### 3.2 Abbreviations

For the purposes of this ETS, the following abbreviations apply:

AC	Authentication Code
ARI	Access Rights Identity
BMC	Broadcast Message Control
C/O	Connection Oriented mode
CK	Cipher Key
CN	Carrier Number
CRFP	Cordless Radio Fixed Part
DCK	Derived Cipher Key
DECT	Digital Enhanced Cordless Telecommunications
DLC	Data Link Control
ETR	European Telecommunication Report
FMID	Fixed part MAC Identity
FP	Fixed Part
FT	Fixed radio Termination
IPUI	International Portable User Identity
IWU	Inter Working Unit
KSG	Key Stream Generator
LCE	Link Control Entity
LLME	Lower Layer Management Entity
MAC	Medium Access Control
MBC	Multi Bearer Control
MMI	Man Machine Interface
NWK	Network
OA&M	Operation, Administration and Maintenance
PA	Portable Application
PARI	Primary Access Rights Identity
PARK	Portable Access Rights Key
PHL	Physical Layer
PMID	Portable part MAC Identity
PP	Portable Part
PT	Portable radio Termination
PUN	Portable User Number
REP	Repeater Part
RFP	Radio Fixed Part
RFPI	Radio Fixed Part Identity
RMBC	Relay Multi Bearer Control
RPN	Radio fixed Part Number
RX	Receive
SAP	Service Access Point
SN	Slot pair Number
TBC	Traffic Bearer Control
TBR	Technical Basis for Regulation
TPUI	Temporary Portable User Identity
TX	Transmit
WRS	Wireless Relay station

## 4 Wireless Relay Station (WRS)

### 4.1 Introduction

A WRS is a physical grouping that contains both Fixed radio Termination (FT) and Portable radio Termination (PT) elements, and that transfers information between a Radio Fixed Part (RFP) and a Portable Part (PP). The FT element acts towards a PP exactly as an ordinary RFP. The PT element acts like a PP towards the RFP, and is locked to the closest RFP. The WRS contains inter-working between its FT and its PT, including transparent transfer of the higher layer DECT services. WRS links may be cascaded.

Compared to an RFP, a WRS may introduce capacity restrictions to the services offered. The restrictions may increase with the number of cascaded WRS links (hops). Single WRS link applications can be generally applied. However, special precautions are needed when applying cascaded WRS links. The capacity may be too low, or there may be a need to adjust the echo control requirements.

A WRS shall comply with the general FT identities requirements for RFPs. Installing or adding a WRS to a DECT infrastructure is not possible outside the control of the system operator/installer/owner, who provides the required system identities, access rights and authentication/encryption keys.

### 4.2 Description

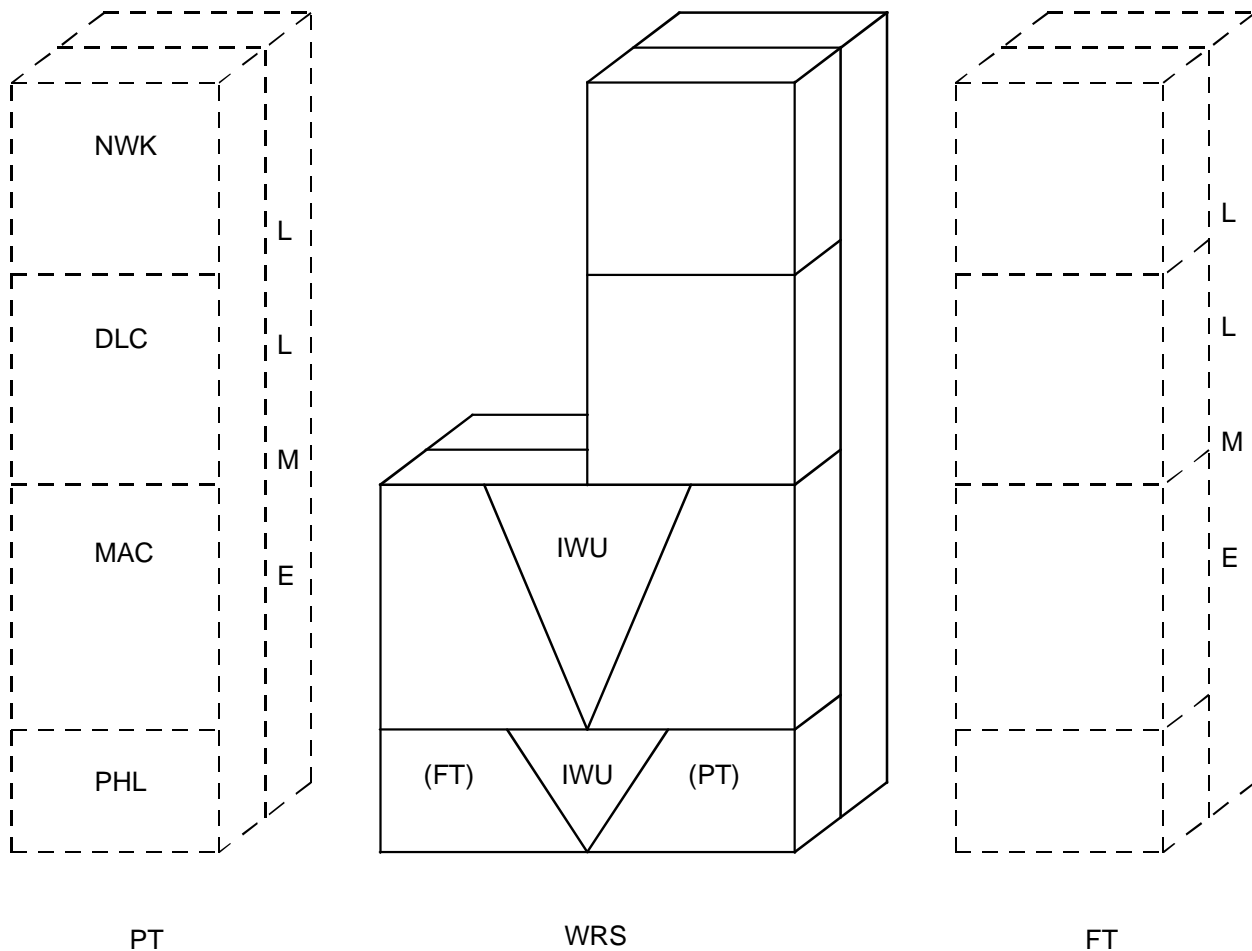

Figure 1: WRS reference model, Protocol stack model

The WRS, as shown in figure 1, provides inter-working on the DECT air interface between a PT and an FT as described in ETS 300 175, Parts 1 to 8, [1] - [8].

The PT may also be the PT side of a WRS in a multi-hop scenario.

The reference model of figure 1 establishes the following basic principles of the WRS:

- inter-working with PTs as defined by ETS 300 175 , Parts 1 to 8, [1] - [8];
- inter-working with FTs as defined by ETS 300 175, Parts 1 to 8, [1] - [8], with additions defined in this ETS;
- inter-working between PT and FT side is provided at Medium Access Control (MAC) layer and Physical (PHL) layer;
- a logical grouping of PT and WRS operates as a PT;
- a logical grouping of FT and WRS operates as a FT.

Looking towards the PT the WRS is fully protocol transparent. The PT cannot distinguish the WRS from any other RFP within an FT. Therefore, the WRS puts no additional requirements on the PT.

#### **4.2.1 PHL layer functions**

The WRS shall fulfil the following PHL layer requirements:

- the WRS shall for the relevant packet type meet the PP requirements in ETS 300 175-2 [2] when it is acting as a PP, and meet the RFP requirements in ETS 300 175-2 [2] when it is acting as an RFP, except that the timing requirements in ETS 300 175-2 [2], subclause 4.2.4. shall be met by all WRS transmissions and that the requirement in ETS 300 175-2 [2], subclause 4.2.5 on difference between reference timers shall be disregarded;
- Z-field mapping as defined in ETS 300 175-2 [2], subclause 4.8 shall be supported.

#### **4.2.2 MAC layer functions**

The WRS provides inter-working at the MAC layer. The WRS incorporates PT and FT functions as defined in ETS 300 175-3 [3].

The WRS shall fulfil the obligatory requirements of ETS 300 175-3 [3], subclauses 11.4 and 11.6, with the modifications as defined in this ETS.

#### **4.2.3 Data Link Control (DLC) layer functions**

The WRS may incorporate DLC layer PT functionality to support communication with the FT according to ETS 300 175-4 [4].

#### **4.2.4 NWK layer functions**

The WRS may incorporate NWK layer PT functionality to support communication with the FT according to ETS 300 175-5 [5].

##### **4.2.4.1 Over-the-air maintenance**

If Operation, Administration and Maintenance (OA&M) information transfer is supported, it may use the <<IWU-TO-IWU>> information element (see ETS 300 175-5 [5], subclause 7.7.23) in NWK layer messages. This element can accommodate unstructured user specific data. For over the air maintenance, a link towards the WRS is created using the PP identity of the WRS.

#### 4.2.5 Identities

The WRS shall have a specific Radio fixed Part Number (RPN) identity and Portable Access Rights Key (PARK). The RPN may be transferred by over-the-air maintenance procedures. For transferring the RPN to the WRS, the Fixed Identity information element with identity type "ARI + RPN for WRS" should be used.

The WRS may have additional specific PT identities when PT DLC and NWK layer functionality is included.

#### 4.3 Services

The WRS may be used in all applications as defined in ETR 043 [9]. Typical WRS applications are presented in ETR 246 [10].

The WRS shall provide a relay service for MAC layer connection oriented, broadcast and connectionless services as defined in ETS 300 175-3 [3], subclauses 5.6 and 5.7.

The WRS shall provide the services as given in table 1.

**Table 1: WRS services**

	<b>Offered service</b>	<b>Support</b>	<b>Comment</b>
S.1	Transparency between PT and FT	Yes	
S.2	MAC services	Yes	All, see ETS 300 175-3 [3]
S.3	Over the air maintenance	Optional	
S.4	PT services (e.g. authentication)	Optional	As applicable for a certain application (e.g. based on a profile)

#### 4.4 Procedures

##### 4.4.1 PHL layer

The WRS shall conform to the PT and FT procedures as defined by ETS 300 175-2 [2].

##### 4.4.2 MAC layer

The WRS shall conform to the PT and FT procedures as defined by ETS 300 175-3 [3].

##### 4.4.2.1 Extended fixed part capabilities

The FP can control the hop configuration and indicate the admitted WRS scenarios by means of the extended fixed part capabilities message (see ETS 300 175-3 [3]).

The extended fixed part capabilities message shall be sent by all WRSs at least once every 8 multiframes, and all WRSs shall understand this message. The WRS shall assume all WRS support bits being set to "0" when the FT does not transmit the message.

##### 4.4.2.2 Hop control

The WRS that is locked to an FT shall decrease the value HOPS (when > 0) of the corresponding WRS type (CRFP or REP respectively; see chapters 5 and 6) in the received extended fixed part capabilities message (see ETS 300 175-3 [3], subclause 7.2.3.5.2.1) for the transmission of its own extended fixed part capability information.

NOTE: The number of hops should be no more than one. Use of more than one hop may be subject to agreement with national radio authorities.

## 5 Cordless Radio Fixed Part (CRFP)

This clause defines requirements in addition to the general requirements for the WRS in clause 4.

### 5.1 Description

#### 5.1.1 General

This description avoids defining specific implementations of the CRFP for a certain application. ETR 246 [10] clarifies the operation of the CRFP for typical applications. This description defines the architecture model of the CRFP and additional messages and procedures necessary to support the CRFPs in the DECT environment.

In this description the full slot frame multiplexing structure and IN\_minimum\_delay speech service are used for descriptive purposes only, and not to restrict the application of the CRFP to a specific slot structure or service.

#### 5.1.2 Reference model

The reference model of figure 1 is applicable for the CRFP. The PT side of the CRFP is called CRFP\_PT. The FT side of the CRFP is called CRFP\_FT.

To support a CRFP, the following additional procedures are defined for the FT:

- MAC layer: access control of CRFP (for specific information transfer to CRFPs);
- NWK layer: Cipher Key (CK) transfer to CRFP.

The following functions are defined for the CRFP based on ETS 300 175, Parts 1 to 8 [1] - [8]:

- FT and PT PHL and MAC layer to provide independent bearer control to PTs and FT;
- a selection of PT DLC and NWK layer to support communication between CRFP and FT.

The following additional functions and procedures are defined for the CRFP:

- IWU at MAC and PHL layer to provide inter-working between CRFP\_PT and CRFP\_FT;
- access control procedures to support both relay and local handling of data on the same bearer;
- CK uploading and initialization for CRFP\_FT MAC.

#### 5.1.3 MAC layer functions

##### 5.1.3.1 General

The basic function of the CRFP is defined by its frame multiplexing structure. Procedures are defined based on this structure to allow the CRFP to support required services.

5.1.3.2 Frame multiplexing structure

Figure 2 shows the typical frame multiplexing structure for a CRFP that supports full slots with IN\_minimum\_delay.

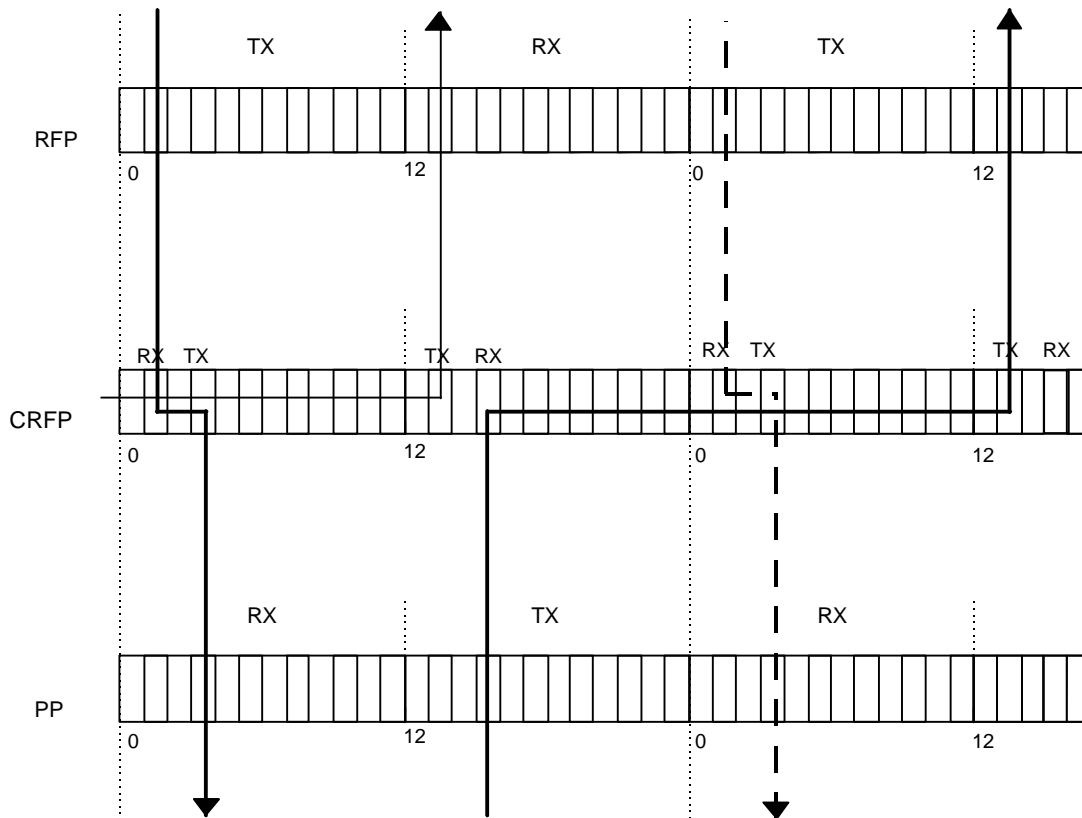

Figure 2: Typical frame multiplexing structure of the CRFP

The frame multiplexing structure supports a combination of both links with PTs and FTs. In this dual frame multiplexing structure the CRFP may transmit or receive during any slot of a frame. A duplex bearer to either the PT or FT is still supported by a combination of an CRFP Receive (RX) and Transmit (TX) slot separated by one half frame.

The CRFP shall support the frame multiplexing structure defined as:

- CRFP-PT frames and CRFP-FT frames are synchronized to the FT frames;
- CRFP-PT and CRFP-FT bearer control complies at least with ETS 300 175-3 [3] (e.g. Duplex bearers are separated by one half frame);
- relayed logical channels are buffered to support MAC multiplexing rules of CRFP-PT and CRFP-FT;
- available slots of the CRFP are marked to be either Receive (RX) or Transmit (TX) slots. A slot shall be regarded as TX slot only when it is actually used for transmission.

NOTE 1: During the first half frame (e.g. Slot 0 to 11) all RX slots listen to FT transmissions and all TX slots transmit to PTs. During the second half frame all RX slots listen to PTs and all TX slots shall transmit to FT.

- RX and TX slots of one relayed bearer belong to the same half frame.

NOTE 2: In idle mode the CRFP listens to an FT during all frames, transmits at least one dummy bearer (see ETS 300 175-3 [3]) to PTs and performs receiver scanning on all other slots. Idle receiver scanning is done in accordance with PT and FT idle receiver scan procedures.



### 5.1.3.3 Logical channel mapping

The CRFP\_PT and CRFP\_FT shall fulfil the multiplexing rules as defined in ETS 300 175-3 [3].

Handling of logical channel data received at CRFP\_PT shall be as follows:

- ME-SAP (Q, N, P, M): data shall be delivered to the Lower Layer Management Entity (LLME) of CRFP. The LLME of the CRFP shall also generate information for the BMC of the CRFP\_FT;
- MA-SAP (B<sub>S</sub>): data shall be delivered to the higher layer and to the IWU of the CRFP. The IWU shall issue a MAC-PAGE.Req for the BMC of the CRFP\_FT;
- MB-SAP (C<sub>L</sub>, S<sub>IN</sub>, S<sub>IP</sub>): data shall be delivered to the higher layer and to the IWU of the CRFP;
- MC-SAP (C, I, G<sub>F</sub>): U-plane data shall always be relayed by the IWU. Depending on the CRFP state, the C-plane data shall be delivered as follows:
- in "local state", all C-plane data is delivered to higher layers;
  - in "relay state", all C-plane data is delivered to the IWU for relay at CRFP\_FT.

The local and relay state of a connection are defined in subclause 5.3.1.1.

All other logical channel data is handled locally in the CRFP\_PT and CRFP\_FT MAC. Logical channel data received at CRFP\_FT related to the MB-SAP and MC-SAP shall be delivered to the IWU for relay. ME-SAP data shall be delivered to the LLME of the CRFP.

#### Delay logical channels:

Logical channel information that is relayed in the CRFP shall bear a minimum delay within the constraints of the multiplexing rules as defined in subclause 6.2.2 of ETS 300 175-3 [3]. IN\_minimum\_delay information, like speech, shall be relayed in the same or next frame, depending upon bearer position.

### 5.1.3.4 Quality Control and Flow Control

The CRFP has separate quality control and flow control on the two links.

For C-channel and I<sub>P</sub> channel flow control, for antenna switch requests and sliding collision detection, the BCK and Q2 bits shall be used for each link and the procedures as described in ETS 300 175-3 [3] shall be followed for each link independently.

If the CRFP receives a B-field with corrupt I<sub>N</sub> data (X-CRC failed) then it shall relay this data and change the B-field identifications (a<sub>4</sub>, a<sub>5</sub> and a<sub>6</sub> bits) to "001"B.

If the CRFP receives a B-field with corrupt I<sub>P</sub> error detect data then it shall relay this data and change the B-field identifications (a<sub>4</sub>, a<sub>5</sub> and a<sub>6</sub> bits) to "000" B.

### 5.1.4 NWK layer functions

Additional functionality in NWK layer and LLME of both FT and CRFP is defined to support over-the-air CK transfer (for encryption of relayed connections) and OA&M.

## 5.1.5 Identities

### 5.1.5.1 Identities and addressing

The connections in the CRFP are identified by Portable part MAC Identities (PMIDs).

Relayed connections shall use the PMID of a PT.

Connections in local state shall use a PMID of the CRFP. To allow multiple local connections simultaneously, the CRFP shall provide multiple PMIDs. Each PMID should be related to a different International Portable User Identity (IPUI) of the CRFP. Therefore the CRFP may comprise multiple IPUIs.

Both in relay state and local state, the FMID used to address a CRFP is derived from the PARI of the FT and the RPN of the CRFP and the FMID used to address a RFP is derived from the PARI of the FT and the RPN of the RFP according to ETS 300 175-3 [3].

The PARK should be the same for all IPUIs of the CRFP.

At the NWK layer the FT can address the CRFP as a PT. The CRFP may define one IPUI of the available ones, that shall be used for over-the-air maintenance. The FT may address other IPUIs of the CRFP to derive Derived Cipher Key (DCK) from a User Authentication Key (UAK).

### 5.1.5.2 Subscription data

In order to ensure inter-working of the CRFP within a FP with PTs, it is necessary to install the parameters given in table 2 into the CRFP during subscription. The installation procedure is implementation dependent and may require a Man Machine Interface (MMI). It is recommended to use over-the-air maintenance procedures to allow on-air installation of most parameters.

**Table 2: CRFP parameters**

Parameter	Optional/ Mandatory	Value	Comment
RPN	M	All	PARI is relayed from FT and combined with RPN of CRFP to provide RFPI
PARK	M	All	PARK should be the same for all CRFP users
IPUI (1..n)	O	All	n is the number of CRFP users
UAK/AC (1..n)	O	All	n is the number of CRFP users
CK	O	All	CK may be derived from UAK
NOTE:	The number of CRFP users is the maximum number of simultaneous connections from the CRFP that require higher layer control in the CRFP.		

## 5.2 Messages

### 5.2.1 MAC layer control

The CRFP uses the messages indicated with "\*" in ETS 300 175-3 [3], subclauses 7.2.5.2.2, 7.2.5.3.1 and 7.3.3.1 only, with the "first PT transmission" code for the first transmission to an FT. For all other transmissions of these messages the CRFP shall use these messages without the "first PT transmission" code.

In all following message diagrams, the notation access.req indicates an access.req message with the "first PT transmission" code, and the notation \*access.req indicates a message without the "first PT transmission" code.

5.3 Procedures

5.3.1 MAC layer

5.3.1.1 Connection Oriented mode (C/O) procedures at CRFP

The following procedures provide means to address CRFPs on one physical relayed connection of a FT with a PT. The connection with the PT is either in relay state or local state. In relay state, all higher layer C-plane signalling shall be relayed by the CRFPs between FT and PT. In local state, all higher layer C-plane signalling shall be buffered at the FT and CRFP. The local state is a temporary state to allow higher layer communication between FT and a specific CRFP.

5.3.1.1.1 Creation of a Relay Multi Bearer Control (RMBC)

To perform a relay function in the CRFP, a RMBC is defined in the MAC IWU. The creation of an RMBC in the IWU of the CRFP is very similar to the creation of MBCs as specified in ETS 300 175-3 [3], subclause 10.2.4.1.

To set-up a relay service the RMBC can use a normal bearer set-up or a dual bearer set-up depending on the current mode of the CRFP (subclause 5.3.5.1).

5.3.1.1.2 Normal C/O bearer set-up

Using the normal bearer set-up the FT does not recognize that the bearer set-up is arriving from a CRFP, the CRFP\_PT operates as a PT. The CRFP connection shall always be in "relay state".

Below the calling side shall be the initiating PT or FT for a bearer set-up. The called side shall be the destination PT or FT. Figure 3 shows the time-message diagram for basic set-up.

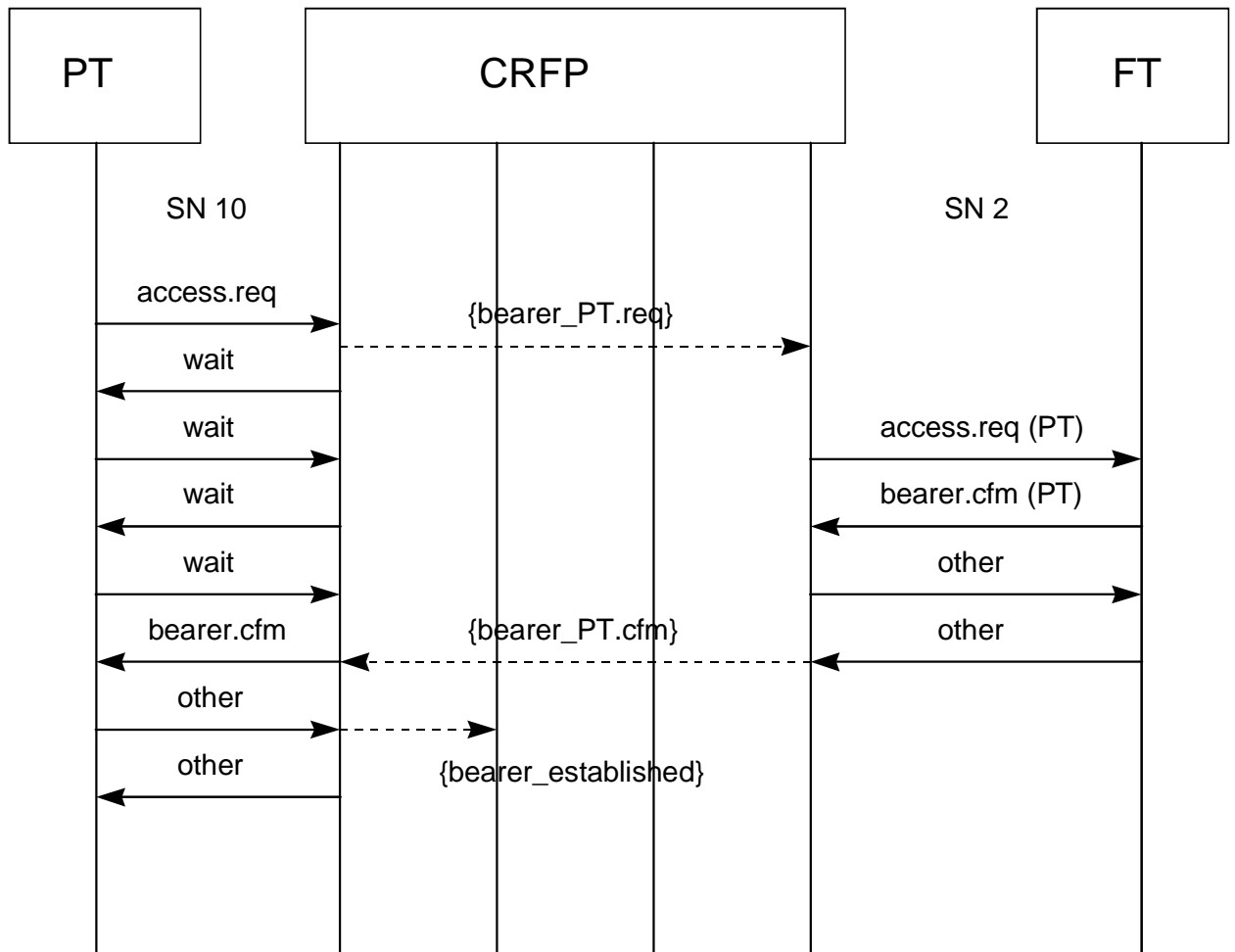

Figure 3: Normal relay bearer set-up

During the bearer set-up procedures TBC<sub>1</sub>, that has been created at the CRFP due to a "access\_request", requests the LLME to be connected to an MBC. If the connection does not exist, the LLME shall create an RMBC in the CRFP. In the mean time TBC<sub>1</sub> transmits "wait" messages to the calling side.

The RMBC shall create a new TBC (TBC<sub>2</sub>) at the other side of the CRFP and shall issue the called address (FMID/PMID) and physical channel description to TBC<sub>2</sub>. The PMID and FMID of the called and calling parties shall be used (not a CRFP PMID, FMID). The CRFP TBC<sub>2</sub> initiates a bearer set-up by transmitting the corresponding "access\_request" to the called side.

If the bearer set-up is successful (after "other" received error free) TBC<sub>2</sub> reports "bearer\_established" to the RMBC. The RMBC informs the LLME that the requested MBC is connected and TBC<sub>1</sub> is allowed to transmit "bearer\_confirm" to the calling side.

**5.3.1.1.3 Dual C/O bearer set-up**

Using the dual bearer set-up the FT shall recognize that the bearer set-up is arriving from a CRFP. The FT can therefore control the state of the CRFP connection using the connection identity of CRFP local service (specific PMID).

Below the calling side is the initiating PT or FT for a bearer set-up. The called side is the destination PT or FT. Additional access procedures for the FT are defined below. Figure 4 shows the time-message diagram for basic connections.

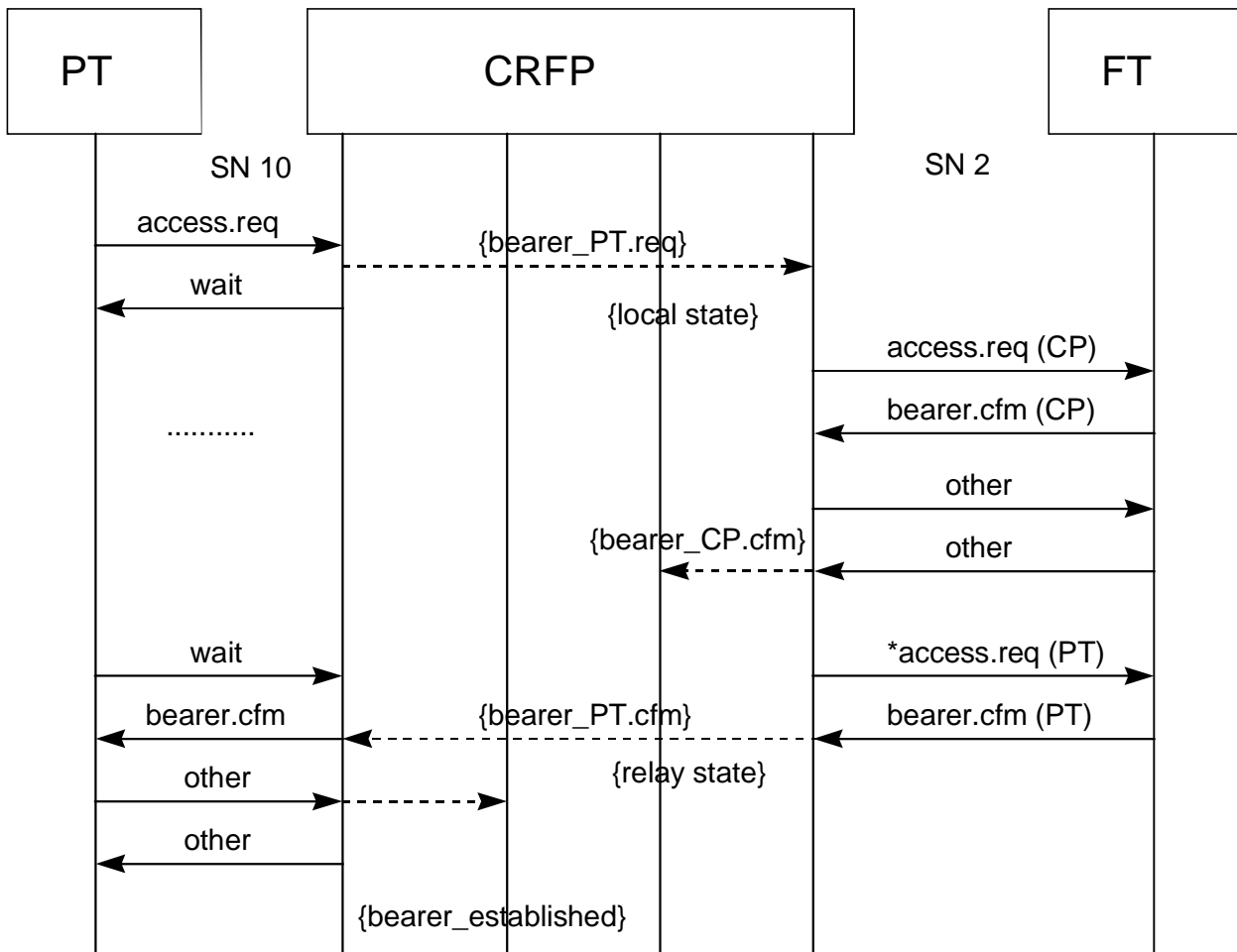

**Figure 4: Dual relay bearer set-up**

### At the CRFP

During the bearer set-up procedures the TBC, that has been created at the CRFP due to a "access\_request", asks the LLME to be connected to an MBC. If the RMBC related to this connection does not exist, the LLME creates an RMBC and a MBC for the CRFP\_PT and CRFP is by definition in "local state". In "local state" the RMBC activities are suspended. The creation of the MBC is reported to the DLC by issuing a MAC-CON.Ind primitive after the first successful bearer set-up with the FT.

The MBC creates a TBC for set-up of a single duplex bearer connection (with the same slot type as requested by the PT) to an FT and issues the called address (FMID/PMID) and physical channel description to the new TBC. The PMID of the CRFP shall be used.

NOTE: This connection is necessary for CK transfer.

After the TBC has reported "bearer\_established" to the MBC, the MBC reports the successful set-up of the connection to the LLME, which changes the state of the CRFP for this connection to "relay state". The MBC activities are now suspended and RMBC activities are resumed.

If a TBC exists with the called side, the RMBC shall now relay the "access\_request" on that TBC without the "first PT transmission" code, with the PMID and FMID of the called and calling parties (not a CRFP PMID, FMID).

If the bearer set-up is successful (after "other" received error free) the TBC reports "bearer\_established" to the RMBC. The RMBC informs the LLME that the requested MBC at the called side is connected and the TBC is allowed to transmit "bearer\_confirm" to the calling side.

#### 5.3.1.1.4 C/O connection release

### At the CRFP

When the CRFP receives a release message with the PMID indicating the MBC of the CRFP, the CRFP shall release that MBC.

When the CRFP RMBC is released, the CRFP shall release all corresponding TBCs and MBC at both CRFP\_PT and CRFP\_FT.

Figure 5 shows the procedure for basic connections.

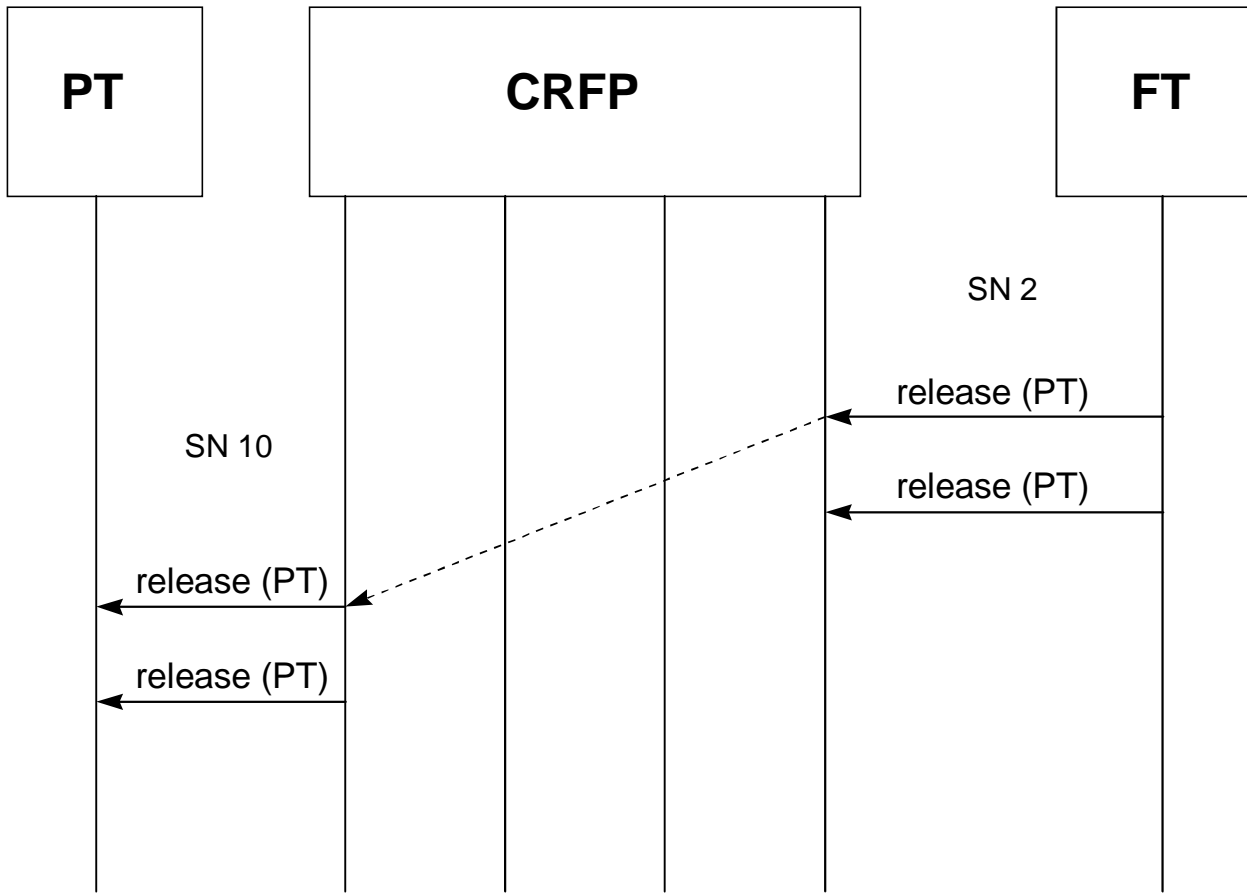

Figure 5: Release

5.3.1.1.5 C/O abnormal connection release

If the CRFP detects an abnormal loss of signal, the CRFP shall release all corresponding TBCs, MBC and RMBC at both CRFP\_PT and CRFP\_FT.

For the release messages generated by the CRFP the PMID of the CRFP shall be used in difference to the normal release cases.

Figures 5a and 5b show the procedures for abnormal connection release.

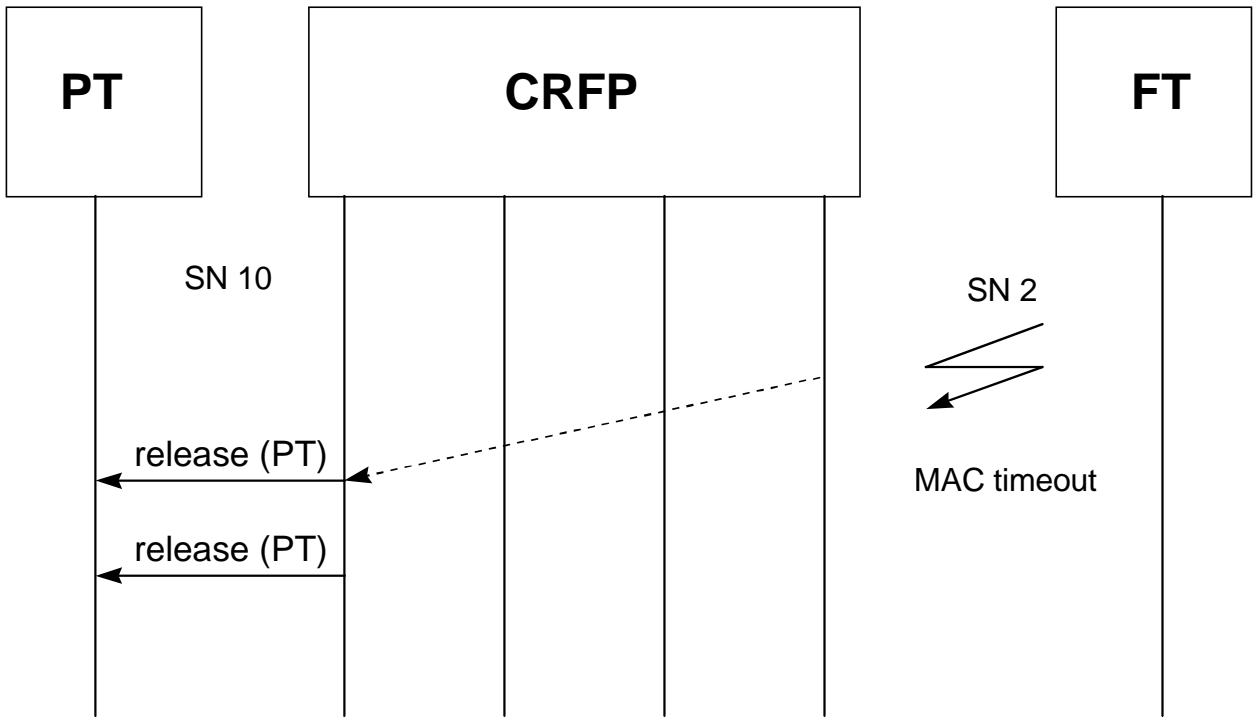

Figure 5a: Abnormal release at CRFP\_PT

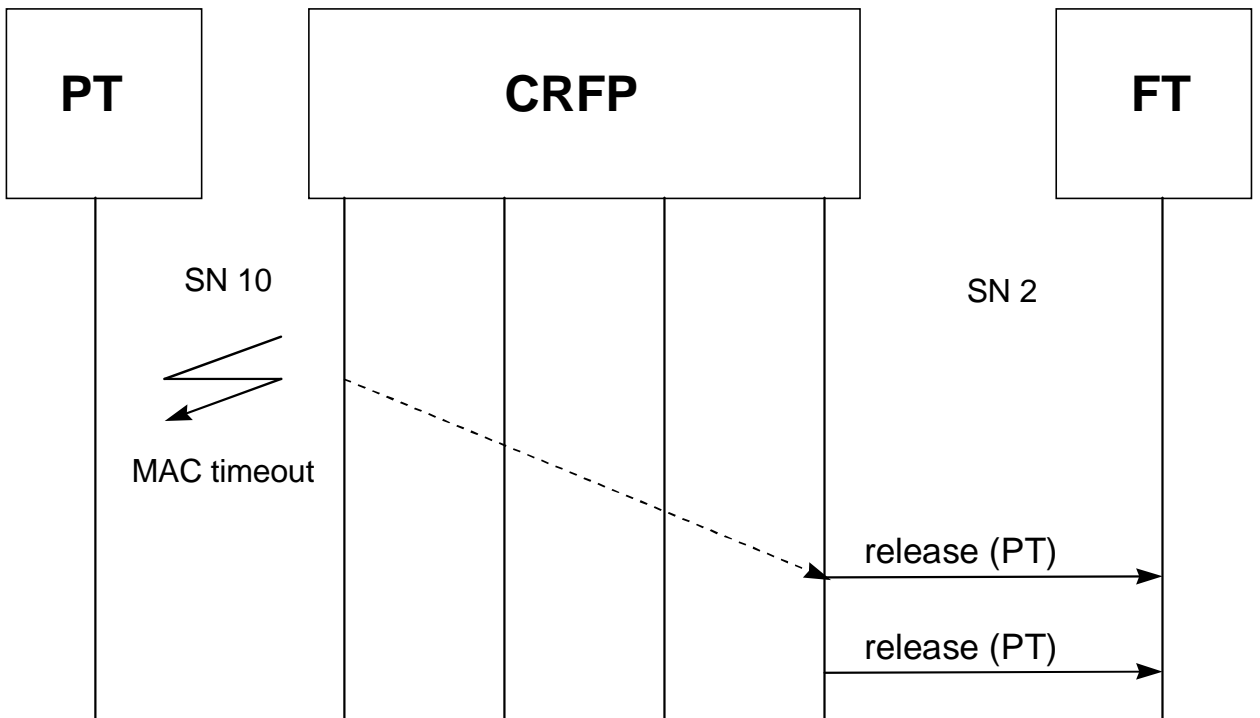

Figure 5b: Abnormal release at CRFP\_FT

### 5.3.1.2 CRFP connection suspend and resume

#### At the CRFP

When an existing TBC at the CRFP\_PT receives an "access\_request", the TBC shall ask the LLME to connect to the (R)MBC indicated by the PMID in the message. If the connection with the (R)MBC is possible, the LLME shall suspend the connection with the old (R)MBC. The LLME shall not activate the connection with another (R)MBC, until all outstanding C-channel data in the TBC is successfully transmitted to the FT. Then the LLME shall ask the TBC to transmit "bearer\_confirm" and resume the connection with the assigned (R)MBC.

If the access.req is not answered, then the access.req message may be repeated twice.

The CRFP is in "local state", when the TBC is connected with an MBC. The CRFP is in "relay state" when the TBC is connected to an RMBC.

In case of a basic connection, the access request and bearer confirm messages belong to the basic connection control set and in case of an advanced connection, the access request and bearer confirm messages belong to the advanced control set.

In order to establish a CRFP state transition, the FT NWK layer (MM entity) issues a DL-CRFP-STATE-SWITCH primitive to the FT DLC layer. The FT DLC layer issues a MAC-CRFP-STATE-SWITCH primitive to the FT MAC layer. After receiving this primitive, the FT MAC layer requests for a CRFP state transition.

DL-CRFP-STATE-SWITCH {req} primitive parameter list:

Parameter	req
Direction	X
X = parameter exists	

MAC-CRFP-STATE-SWITCH {req} primitive parameter list:

Parameter	req
Direction	X
X = parameter exists	

Direction = {local to relay, relay to local}

The FT MAC layer can inform the DLC layer about the CRFP state by means of a MAC-CRFP-STATE primitive. The FT DLC layer informs the FT NWK layer (MM entity) about the CRFP state by means of a DLC-CRFP-STATE primitive.

DL-CRFP-STATE-SWITCH {ind} primitive parameter list:

Parameter	ind
State	X
X = parameter exists	

MAC-CRFP-STATE-SWITCH {ind} primitive parameter list:

Parameter	ind
State	X
X = parameter exists	

State = {local, relay}

Figure 6 shows time-message diagrams for basic connections.



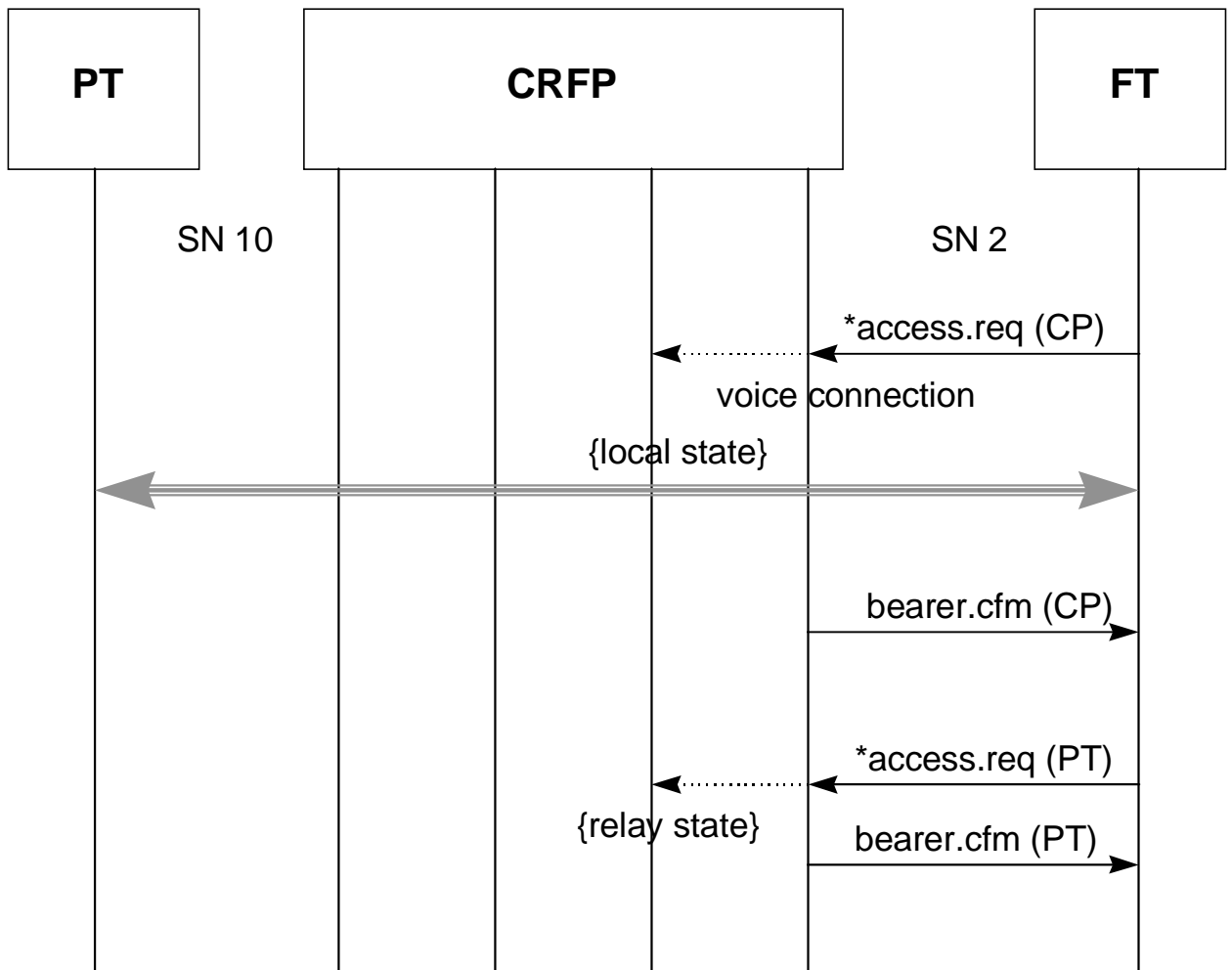

Figure 6: CRFP connection suspend and resume

### 5.3.1.3 C/O bearer handover

Bearer handover procedures may be used to perform:

- 1) intra-cell handover of the PT within the CRFP;
- 2) intra-cell handover of the CRFP within one RFP;
- 3) inter-cell handover of the CRFP from one RFP to an RFP belonging to the same cluster;
- 4) inter-cell handover of the PT from an CRFP to an RFP belonging to the same cluster;
- 5) inter-cell handover of the PT from an RFP to a CRFP belonging to the same cluster;
- 6) inter-cell handover of the PT from one CRFP to a CRFP belonging to the same cluster;
- 7) inter-cell handover of the CRFP from one CRFP to a CRFP belonging to the same cluster.

The CRFP may be defined as a separate cluster or as part of the cluster of the RFP(s) that it is connected to.

The specific bearer handover procedures shall be handled as follows:

- 1) completely handled at CRFP\_FT using procedures as defined in ETS 300 175-3 [3];
- 2) completely handled at CRFP\_PT using procedures as defined in ETS 300 175-3 [3];
- 3) completely handled at CRFP\_PT using procedures as defined in ETS 300 175-3 [3];
- 4) completely handled by RFP. The connection via the CRFP is released (see figure 7);
- 5) this handover requires the set-up of an RMBC (and MBC) in the CRFP to handle the new bearer. The procedure is identical to the handling of the set-up of a new connection via the CRFP as defined by subclause 5.3.1.1, replacing the "access.req" from the PT with a "bearer\_handover.req" (see figure 8);
- 6) this handover is identical to 5) for the CRFP;
- 7) this handover is a combination of case 3) and 6).

During bearer handover, it is subject of the implementation to avoid loss of signalling and user data. Due to re-arrangement of usage of slots in the CRFP frame multiplexing structure, relay of data may be changed.

NOTE: Due to the extra one frame delay introduced by CRFP, in case of bearer handover it could not be possible to have the same I-channel data (In normal delay and Ip data) on both the new and the old bearer.

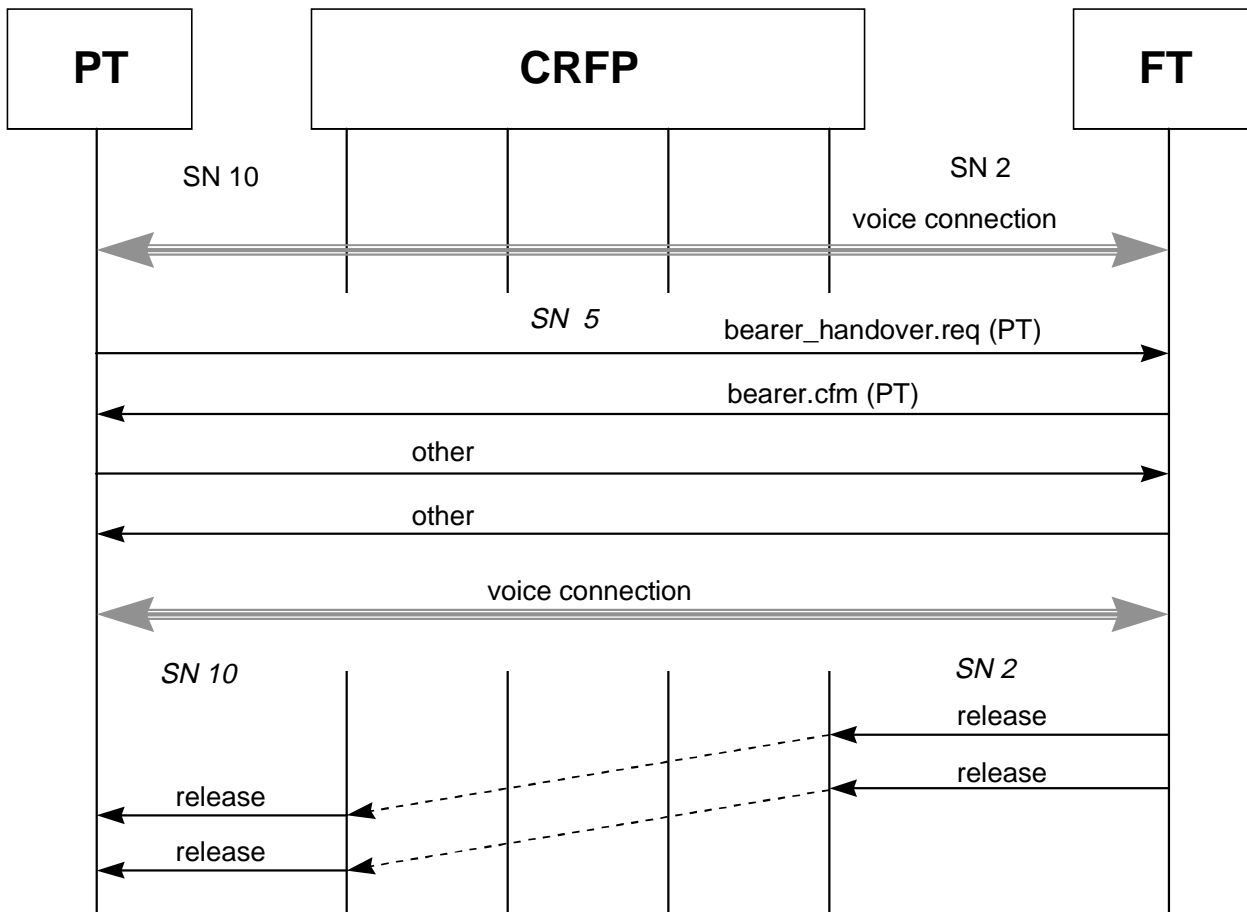

Figure 7: Bearer handover from CRFP to RFP

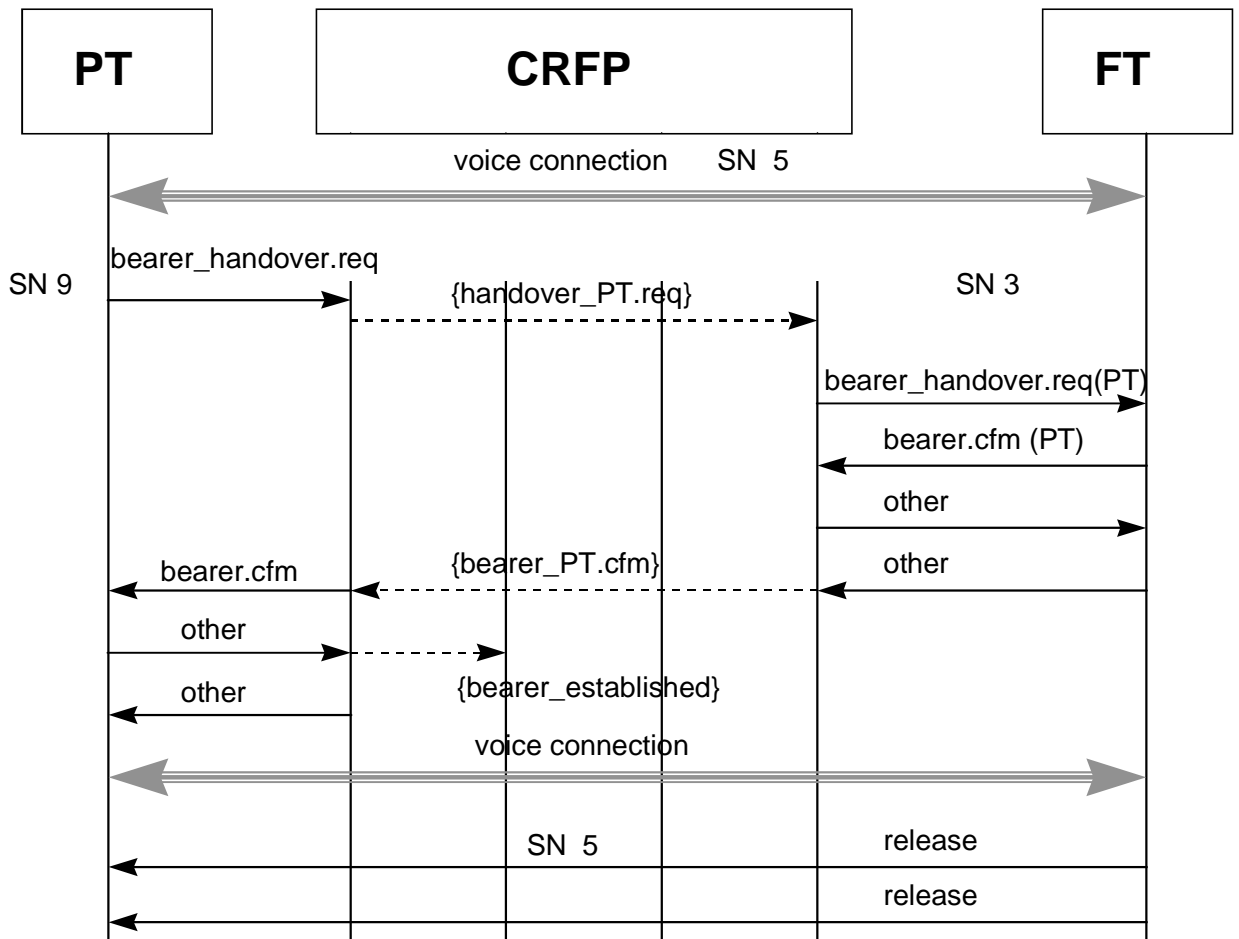

Figure 8: Bearer handover from a RFP to CRFP (normal set-up)

### 5.3.2 DLC layer

#### 5.3.2.1 Connection handover

Connection handover procedures may be used to perform:

- 1) inter-cell handover of the CRFP from one RFP to an RFP;
- 2) inter-cell handover of the PT from an CRFP to an RFP;
- 3) inter-cell handover of the PT from an RFP to a CRFP;
- 4) inter-cell handover of the PT from one CRFP to a CRFP;
- 5) inter-cell handover of the CRFP from one CRFP to a CRFP;
- 6) inter-cell handover of the CRFP from one CRFP (or RFP) to an RFP (or CRFP).

The specific connection handover procedures shall be handled as follows:

- 1) completely handled at CRFP\_PT using procedures as defined in ETS 300 175-4 [4];
- 2) completely handled by RFP. The connection via the CRFP is released;
- 3) this handover requires the set-up of an RMBC (and MBC) in the CRFP to handle the new connection. The procedure is identical to the handling of the set-up of a new connection via the CRFP, replacing the "access\_req" from the PT with a "connection\_handover.req";
- 4) this handover is identical as 3) for the CRFP;
- 5) this handover is a combination of 4) and 1).

#### 5.3.2.2 DLC variables

Switching over from local mode to relay mode includes an implicit release of the DLC-link used for the local mode.

5.3.3 NWK layer

All PT network and higher layer information is relayed through the CRFP. As an example, figure 11 shows a typical outgoing encrypted call set-up with MAC and NWK layer messages via the CRFP.

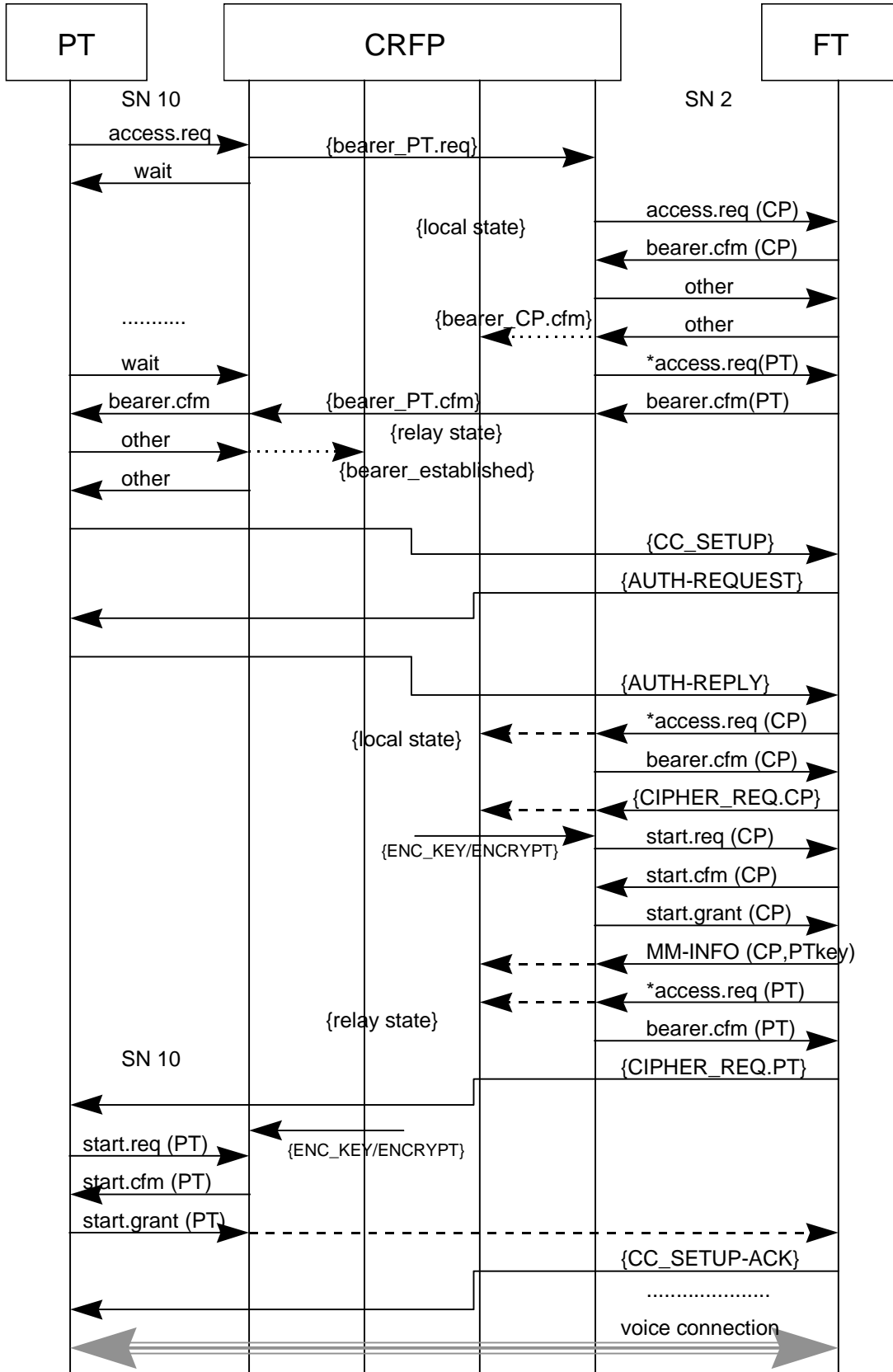

Figure 9: Typical call set-up message diagram (with encryption)

### 5.3.4 Security

#### 5.3.4.1 General

To support encryption for relayed connections via the CRFP, a PT CK needs to be loaded in the CRFP that provides access to the PT. See ETS 300 175-7 [7].

For encryption on a relayed FT-PT connection, different CKs shall be used for links between FT and CRFP and between CRFP and PT. An CRFP CK shall be used for encryption of the FT-CRFP connection and a PT CK shall be used for encryption of the CRFP-PT connection. The PT CK shall be transferred to the CRFP on a ciphered link. Different keys shall be used for different connections between FT and a CRFP.

Figure 10 shows the protocol diagram for the CRFP supporting encryption on these relayed connections.

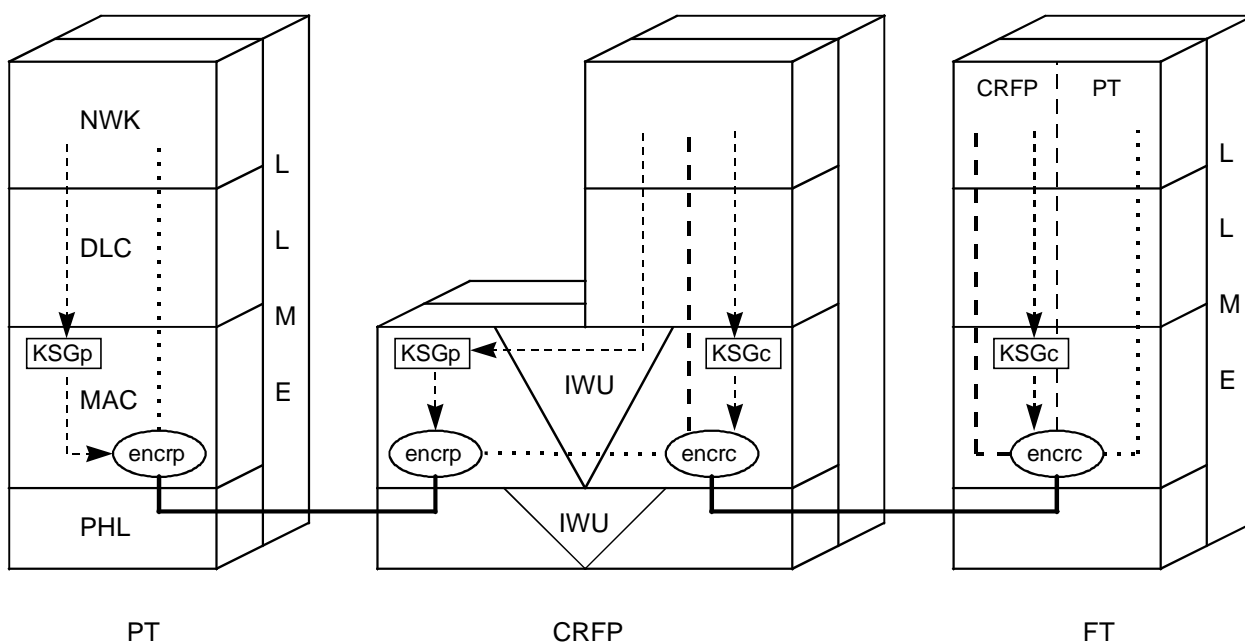

**Figure 10: Protocol stack for encryption**

Figure 10 shows how the principle for ciphering is supported. Separate encryption engines are used to encrypt FT-CRFP and CRFP-PT connections.

The FT shall initiate the procedure for cipher key transfer given in ETS 300 175-7 [7] subclause 7.3.2 when the CRFP requires a cipher key:

- when FT sends a CIPHER\_REQ to a PT that is relayed via a CRFP;
- during bearer or connection handover when the FT receives a relayed handover request.

These procedures with the PT shall be temporarily frozen until the cipher key is transferred to the CRFP or until time-out of the connection.

The CRFP shall relay a received start.grant message.

NOTE: The received PMID is kept and the FMID is replaced by the relevant one.

During bearer handover and connection handover with encryption from a RFP to a CRFP, it is allowed that the FT and CRFP exchange higher layer messages and start messages between the  $M_T$  bearer\_handover.req message (PT PMID) and the  $M_T$  bearer.cfm message.

NOTE: See annex B.

Figures 9 and 11 show typical examples of the procedures for basic connections.

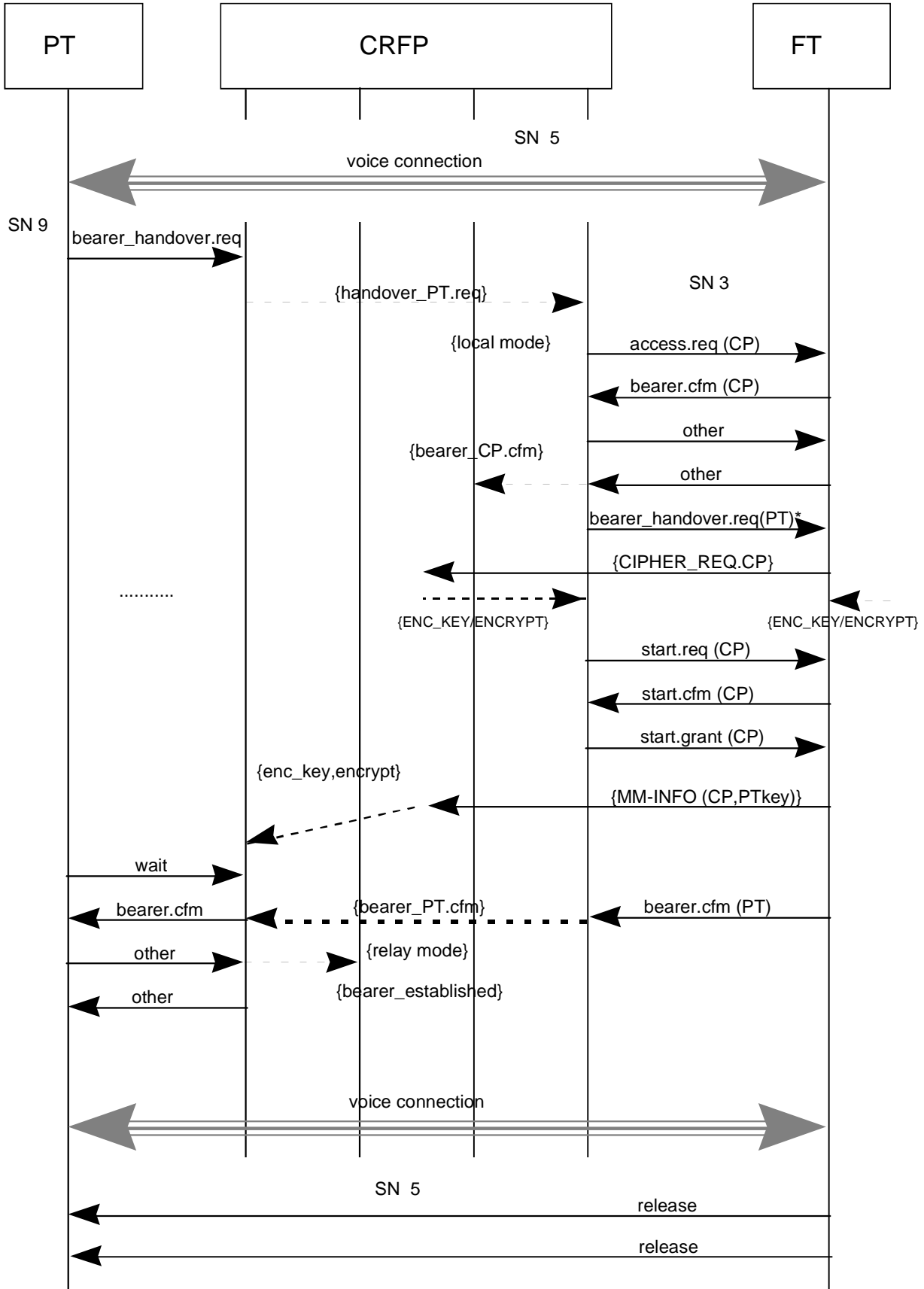

Figure 11: Bearer handover from a RFP to CRFP (dual set-up with encryption)

#### 5.3.4.2 CRFP initialization of PT cipher key

The FT will initiate ciphering between FT and CRFP that requires a PT CK using {CIPHER-REQUEST} message with a CRFP CK (see subclause 5.1.5).

When the connection between the FT and the destination CRFP is completely ciphered, the FT sends the PT CK to the CRFP\_PT using the {MM-INFO-SUGGEST} message.

The CRFP shall download the received CK to the appropriate KSG for the CRFP\_FT. The CRFP shall relate the PT CK to the relayed connection at the MAC layer.

After downloading the CK in the KSG, the CRFP is ready for encryption to be enabled at the MAC layer with the PT whenever needed.

NOTE: The procedure is repeated in multi-hop scenarios. In that case the PT may be the CRFP\_PT of a relayed CRFP set-up or handover.

#### 5.3.5 Management

##### 5.3.5.1 CRFP MAC modes

Two MAC modes are defined for operation of the CRFP with an FT:

- normal MAC mode (PT MAC procedures as defined in ETS 300 175-3);
- dual MAC mode (defined in this subclause).

To support encryption the CRFP shall be able operate in Dual MAC mode towards a FT. This mode shall only be used by the CRFP, when the FT has indicated that it supports CRFP with encryption.

NOTE: The FT may also be the FT side of another CRFP.

##### 5.3.5.2 CRFP states and state transitions

The CRFP combines states of both PT and RFP as defined in ETS 300 175-3 [3].

###### CRFP\_FT:

The CRFP\_FT shall be inactive when the CRFP cannot provide any service to any PTs (i.e. CRFP\_PT is unlocked). After the CRFP\_PT has entered the unlocked state, the CRFP\_FT shall enter the inactive state within T205.

NOTE: The CRFP does not transmit any dummies when it cannot provide a service to PTs.

###### CRFP\_PT:

In addition to the PP requirement for locking, the CRFP shall receive the extended fixed part capabilities message if the FT supports this message. The CRFP\_PT may only enter the locked state when the FT supports the CRFP with HOPS>0.

If the FT supports encryption, the CRFP\_PT may only enter the locked state when the CRFP supports encryption and the FT supports the CRFP with encryption.

## 5.4 Example operation of CRFP

### 5.4.1 Introduction

This subclause is informative and refers to the time-message diagrams for typical General Access Profile (GAP) protocol procedures.

### 5.4.2 Example GAP procedures

In the diagrams the (PT) refers to the PMID of the PT. The (CP) refers to the PMID of the CRFP.

For normal relay bearer set-up see figure 3.

For dual relay bearer set-up see figure 4.

For release see figure 5.

For CRFP connection suspend and resume see figure 6.

For bearer handover from CRFP to RFP see figure 7.

For bearer handover from a RFP to CRFP (normal set-up) see figure 8.

For typical call set-up message diagram (with encryption) see figure 9.

For bearer handover from a RFP to CRFP (dual set-up with encryption) see figure 11.

In each of the figures SN ( ) is the slot number indicating the slot pair (0 - 11) (see ETS 300 175-3 [3], subclause 7.2.3.2.3).

## 6 Repeater Part (REP)

This clause defines requirements in addition to the general requirements for the WRS, (see clause 4).

### 6.1 Description

#### 6.1.1 General

This subclause describes in principle the philosophy applied by REP to relay connections.

A description of the protocol model is given. The new messages and new procedures required are introduced; examples of frame structures and slots allocation to relay connections are given.

#### 6.1.2 Reference model

The reference model of figure 1. is applicable for the REP.

At the PT, the REP does not require any additions.

At the FT, the REP requires the following additions:

- **at the MAC layer:**
  - the Physical set-up Procedure and new Mt messages to establish a physical bearer;
  - the Mapping Procedure and the required new Mt messages;
  - a new bearer concept, the double duplex bearer;
  - a new procedure to release REP relayed connections;

The additional MAC functionalities can be logically located within the Multi-Bearer\_control (MBC) entity (see ETS 300 175-3 [3]);



- **at LLME:**
  - configuration control (number of allowed cascaded REPs; type of repeater supported ea.) with the use of the Q message "Extended Fixed Part Capabilities" (see ETS 300 175-3 [3], subclause 7.2.3.5.2).

A REP shall have MAC and PHL layer functionalities to interface a PT (or another REP) like an FT and MAC and PHL layer functionalities to interface an FT (or another WRS) like a PT. In the PT configuration REP can also have part of a PT DLC and NWK layer functionalities to access directly to the network's services (i.e. to exchange on air OA&M messages; to subscribe etc.).

At REP The following additions are required:

- **at MAC layer:**
  - the physical set-up procedure and new Mt messages to establish a physical bearer;
  - the mapping procedure and the required new Mt messages;
  - a new bearer concept: the double duplex bearer;
  - a new procedure to release REP relayed connections.

An Inter Working Unit (IWU) is required to allow interworking between the REP PT side and the REP FT side at PHL and MAC layers.

### **6.1.3 MAC layer functions**

#### **6.1.3.1 General**

REP shall be compliant with both the PT and the FT MAC layer requirements according to ETS 300 175-3 [3]. Additions are required when interfacing an FT or another WRS and are given in the following subclauses.

#### **6.1.3.2 Frame multiplexing**

REP can switch from transmit to receive modality at each slot. In particular REP, once locked to a suitable FT (other WRS) is listening for bearer set up attempts on the second half frame in the idle slots (i.e. slots where REP does not transmit nor receives) and, in the first half frame and on the idle slots, is scanning for suitable channels and is listening for suitable FTs (other WRSs) to get synchronized to. REP shall scan the radio environment in the second half frame synchronously with the FT (other WRS) locked to scanning sequence.

REP relays the information received from one radio termination to another radio termination, combining Physical and MAC layer functionalities both of a PT and of an FT, with some improvements when interfacing the FP or another WRS. The relay of the information between the two radio terminations is completed within the half frame time interval.

Figure 12 describes the frame structure and slots allocation within REP, RFP and PP for a single duplex bearer relayed connection and for one hop; figure 13 describes the frame multiplexing for two cascaded REPs.

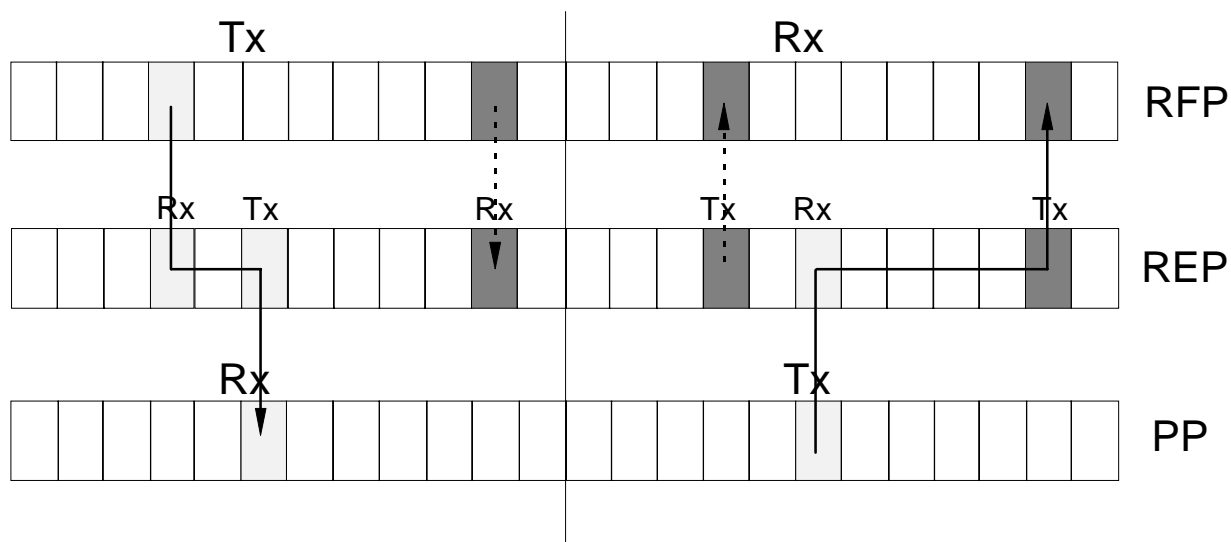

Figure 12: Frame structure and slots allocation for a single duplex bearer connection (1 hop)

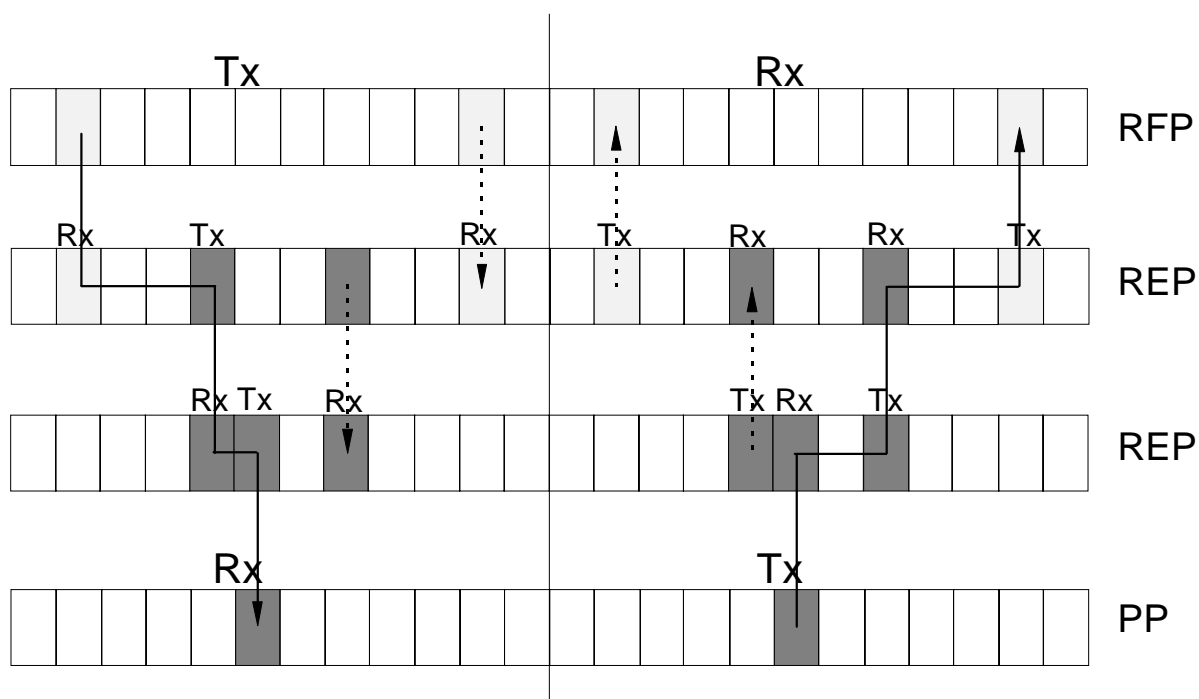

Figure 13: Frame multiplexing for two cascaded REPs

In figure 14 an example of two single duplex bearer connections, REP relayed with an interlacing procedure (see subclause 6.4.1.1.3), is presented; PP1 and PP2 connections share on REP the slot pair (i.e. the duplex bearer) marked with "S".

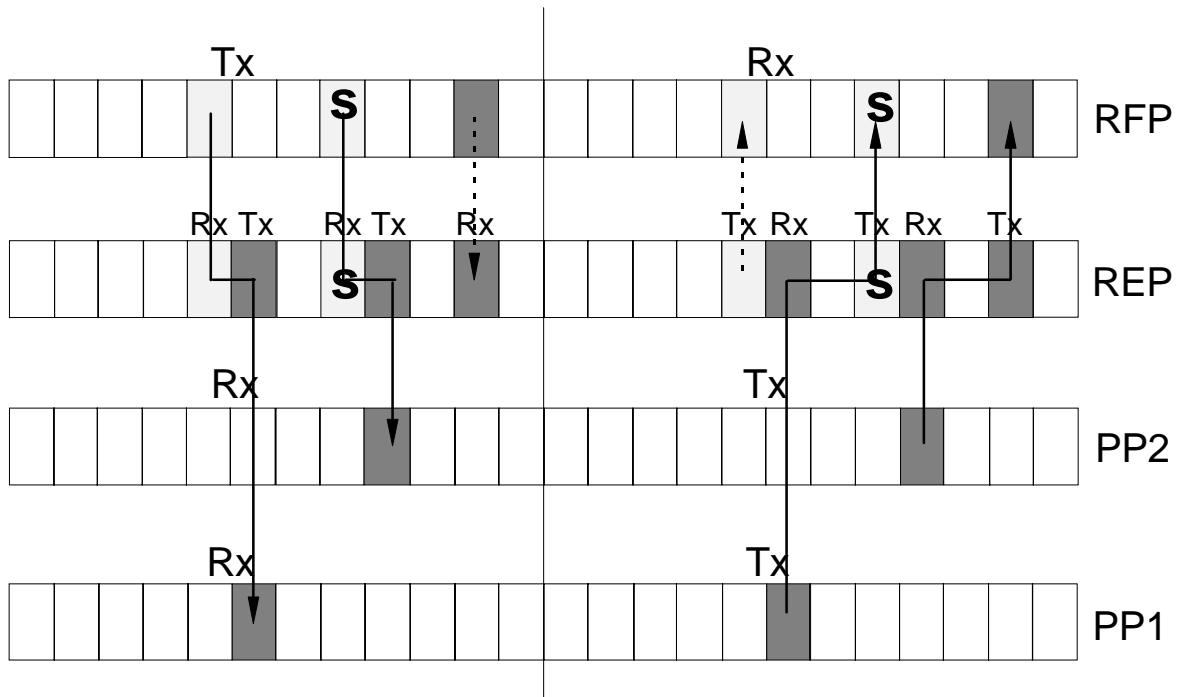

Figure 14: Two single duplex bearer connections, REP relayed with interlacing

#### 6.1.3.2.1 Quality control

REP repeater shall release a bearer and all the related bearers, both in downlink and in uplink direction, if it has not received the correct RFPI with a correct CRC on that bearer in the last T201 seconds.

"Related bearers" are bearers referring to the same connection.

For duplex bearers the Q2 bit is used for C channel flow control and, together with the BCK bit, for Ip channel flow control (see ETS 300 175-3 [3]).

In a duplex bearer belonging to a double duplex bearer (see subclause 6.4.1.1.3) the Q2 and BCK bits shall be set in response to the last received data burst on the other duplex bearer of the pair.

For duplex bearers the Q1 bit can be used in downlink direction to indicate a detected sliding collision and in uplink direction to request a switch of antenna (see ETS 300 175-3 [3]).

In a duplex bearer belonging to a double duplex bearer the Q1 bit always refers to the duplex bearer where it has been set.

#### Q2 bit setting for duplex bearers:

- REP shall not store the received C or I<sub>P</sub> channel data of duplex bearers belonging to a relayed connection. The re-transmission of unacknowledged segments shall be done only by the source transmitter;
- in response to the last received channel data, REP shall set the Q2 bit to '0' if A-CRC failed or C<sub>F</sub> segments rejected or the destination receiver of C segments has set the Q2 bit to '0';
- if A-CRC failed, REP shall send to the destination receiver a data burst where the A-field shall contain a whatever allowed internal MAC channel information (N; P; Q) and, if B-field rejected, the B-field may contain I<sub>N</sub> or I<sub>P</sub> user data depending on the required service;
- in case of I<sub>P</sub> error detect service, if REP receives a B-field with corrupt I<sub>P</sub> data then it shall relay this data and change the B-field identifications (a<sub>4</sub>, a<sub>5</sub> and a<sub>6</sub> bits) to "000"B;
- in case of I<sub>N</sub> service, if REP receives a B-field with corrupt I<sub>N</sub> data (X-CRC failed) then it shall relay this data and change the B-field identifications (a<sub>4</sub>, a<sub>5</sub> and a<sub>6</sub> bits) to "001"B.

#### Q1 bit setting for duplex bearers:

- both in reception and in transmission, REP can independently manage the Q1 bit.

#### 6.1.3.2.2 Bearers selection

To set-up bearers the REP shall follow the channel selection rules as described in subclause 6.4.4.3.

#### 6.1.3.2.3 Establishment of the double duplex bearer

REP shall require, for each duplex bearer to be relayed, a double duplex bearer.

At least one duplex bearer composing the double duplex bearer shall be set up with the same procedure required by the duplex bearer to be relayed. The other duplex bearer shall be setup with a physical setup procedure (see subclause 6.4.1.1.1), if a suitable duplex bearer is not available (suitable means: time positioned in accordance with subclause 6.4.4.3).

A physical set up has not to be notified to the DLC (by a MAC\_CON.ind primitive), and the set-up channel has no properties, it is just a duplex bearer.

As an example figure 14 shows how the first PP1 relayed connection requires both a physical and a PP1 type set-up and how the following PP2 relayed connection requires only a PP2 type set-up on slot pair (10;22), as it can share the already established slot pair (7;19) with the PP1 connection.

#### 6.1.3.2.4 Double simplex bearers

REP can relay double simplex bearers but does not allow a change of the transmission direction of a relayed double simplex bearer (see ETS 300 175-3 [3]).

#### 6.1.3.3 Logical channel mapping

REP shall be compliant both with the PT and with the FT multiplexing rules as defined in ETS 300 175-3 [3].

The multiplexing rules can introduce a delay in the REP re-transmission of the paging messages (not referring to REP) which are broadcast by the FT (other WRS) to which it is locked.

It may be impossible for REP to re-transmit on all the downlink active bearers the received paging messages within the same receiving time frame.

Handling of logical channel data received at REP:

MA-SAP ( $B_S$ ):

REP as a PT:

data shall be delivered to the higher layer and to the IWU of REP for relay; IWU shall issue a MAC-PAGE.req (for each received paging message not referring to REP) to the MBC of the FT MAC REP;

MB-SAP ( $C_L$ ;  $SI_N$ ;  $SI_P$ ):

REP as a PT:

data shall be delivered to the higher layer and to the IWU of REP for relay;

REP as an FT:

C channel data shall be delivered to IWU for relay;

MC-SAP ( $C$ ;  $G_F$ ;  $I$ ):

REP as a PT:

U-plane data shall be delivered to the IWU of REP to relay;  
C-plane data shall be delivered to higher layer for a REP direct connection or to IWU of REP for relay;

REP as an FT:

U-plane and C-plane data shall be delivered to IWU of REP for relay;

ME-SAP ( $Q$ ;  $N$ ;  $P$ ;  $M$ ):

REP as a PT:

data shall be delivered to the LLME of REP; LLME of REP shall also generate information for the MBC of the FT MAC of REP;

REP as an FT:

data shall be delivered to LLME of REP.

#### **6.1.4 DLC functions**

REP can incorporate DLC layer PT functionalities to support communication with the FT according to ETS 300 175-4 [4].

#### **6.1.5 NWK layer functions**

REP can incorporate NWK layer PT functionalities to support communication with the FT according to ETS 300 175-5 [5].

## 6.1.6 Management functions

### 6.1.6.1 Identities and addressing

REP shall have an assigned Radio Fixed Part Identity (RFPI) which shall broadcast as an FT once it has entered the Active\_Idle/Active\_Traffic state (see subclause 6.4.3.1).

The REP RFPI is composed by the PARI, which is broadcast by the FT (other WRS) locked to, and by the RPN, which has been assigned to REP during the subscription phase, according to ETS 300 175-6 [6].

The MAC identity of REP (FMID) as an FT shall be:

FMID = least significant 12 bits of REP RFPI (see ETS 300 175-3 [3]).

REP should have at least one IPUI to have direct access to the system (e.g. for on air subscription, on air OA&M etc.).

To set-up direct connections to the FT, REP shall use an assigned PMID or a default one (see ETS 300 175-3 [3]).

REP relayed connections shall use the PT used PMID. Physical set-up connections (see subclause 6.4.1.1.1) shall use a PMID, which shall unambiguously identify the set-up bearer.

## 6.2 Definitions

REP requires the definition of a new type of bearer, the "Double duplex bearer".

## 6.3 Messages

### 6.3.1 MAC control (Mt)

REP requires the messages of the "REP control set", defined in ETS 300 175-3 [3], for the procedures in the following subclauses.

## 6.4 Procedures

### 6.4.1 MAC layer

#### 6.4.1.1 C/O connection

##### 6.4.1.1.1 Physical set-up procedure

A physical set-up shall always be REP initiated, as explained in the following overview. An existing REP MBC entity shall set-up a physical connection with an FT or another WRS.

## REP

The IWU of the initiating side shall have knowledge of at least one available physical channel. The IWU shall also know the address (FMID) of the called part (FT or another WRS). The IWU shall create the TBC and issue the called address and the physical channel description to the new TBC. The IWU shall also indicate if the wanted bearer is used for bearer handover or for a new set-up and shall specify that a physical set-up procedure is to be used. After this, a physical set-up timer, T200 shall be started, (see ETS 300 175-3 [3]). A successful physical set-up shall be completed before this timer expires. Otherwise the physical set-up fails.

To establish the bearer the TBC shall use the physical set-up procedure.

At the end of a set-up procedure the TBC shall report to the IWU either:

- "bearer\_established" (the procedure succeeded); or
- "bearer\_setup\_failed".

If a bearer set-up attempt failed the TBC shall be released (see ETS 300 175-3 [3], subclause 10.7.2.1). The calling IWU can re-attempt with the same procedure up to N200 times, subject to using a new available channel each time (see ETS 300 175-3 [3]).

NOTE 1: In the case of a successful physical set-up there exists a common identification for the connection known both at the calling and at the called side. It consists of the ARI + PMID. A duplication of the identification is possible only during bearer handover.

NOTE 2: It is assumed that the PMID does not change during one connection (e.g. from an arbitrary PMID to a PMID derived from the assigned individual TPUI (see ETS 300 175-3 [3], subclause 11.7.2)).

The calling side does not require the creation of a new MBC at the called side.

### Called side

At the called side a new TBC is created by receiving a "REP\_bearer\_request" message, including the MAC addresses PMID and FMID on the scanned physical channel. The message type also contains the information that the new bearer belongs to a physical connection.

### MBC identification

The TBC has to receive all necessary parameters to identify an MBC.

The MBC is fully identified after:

- a) receiving with "REP\_bearer\_request" message either a REP\_access request or a REP\_bearer\_handover request (see ETS 300 175-3 [3], subclause 7.2.5.11), including the calling address PMID and defining the connection type as physical; and
- b) receiving the REP\_channel\_map\_request message (see ETS 300 175-3 [3], subclause 7.2.5.11) which indicates the duplex bearer to which the physical set-up bearer has to be linked. This message is necessary only for a new bearer set-up. In the case of a bearer handover request, the old mapping still remains effective.

The reference MBC is the one to which the TBC of the linked bearer belongs.

The TBC issues a PMID, ARI and the REP\_channel\_map message, which, when received at the reference MBC, indicates the purpose of the wanted connection (i.e. bearer handover or a new set-up).

The MBC can now decide:

- a) to release the TBC;
- b) to accept the TBC.

### Procedure

The procedure of a physical bearer set-up is identical to the basic bearer set-up procedure described in ETS 300 175-3 [3], subclause 10.5.1, where:

- the PT is REP and the FT could be also a WRS;
- the exchanged Mt messages belong to the REP control set (see ETS 300 175-3 [3], subclause 7.2.5.11);
- the bearer\_request message can be either a REP\_access.request or a REP\_bearer\_handover.request message.

#### 6.4.1.1.2 Creation of a double duplex bearer

To relay one duplex bearer of a PT connection, REP shall establish towards the FT (other WRS) locked to at least another duplex bearer using  $M_T$  messages of the same PT used connection control set. This bearer shall be called the "relayed bearer".

If a physical bearer set-up is also required to relay the connection, REP shall firstly set up this bearer according to subclause 6.4.1.1.1. A physical bearer set-up is required if REP can not find a suitable bearer (see subclause 6.4.4.3) already established to be interlaced together with the relayed bearer (see subclause 6.4.1.1.3 for definitions).

The  $M_T$  messages are transparently relayed by REP on bearers already established.

#### 6.4.1.1.3 Mapping procedure

This procedure allows the creation of a double duplex bearer, after two duplex bearers have been set up between two far ends. When one of the two duplex bearers already belongs to a double duplex bearer, the procedure is called "interlacing".

##### Procedure:

the sending side:

REP shall send to a far end onto a duplex bearer the REP\_channel\_map.request message (see ETS 300 175-3 [3], subclause 7.2.5.11), indicating to the receiving side that the two duplex bearers are to be mapped together, i.e. to be referred to the same connection. The first SN and Carrier Number (CN) fields within this message, shall indicate the master channel. This is the channel whose reference connection shall become the reference connection for the mapped bearers;

the receiving side:

after receiving without errors the REP\_channel\_map.request message onto a duplex bearer, can decide:

- a) to accept to map together the indicated channels; or
- b) to reject to map together the indicated channels.

While not ready to send REP\_channel\_map.confirm, the receiving side shall send wait messages:

the sending side shall answer with wait messages;

when ready it shall send back onto the same duplex bearer the REP\_channel\_map.confirm message setting the A/R flag to Accepted (case(a)) or Rejected (case (b)).

Case (b) may apply when interlacing of the two duplex bearers is requested and the receiving side does not support interlacing.

If case (a) applies, a double duplex bearer has been created.

Within the double duplex bearer the two duplex bearers shall exchange their simplex bearers such that the information flow (i.e. higher layer signalling and user data), for the uplink transmission direction, shall use the uplink simplex bearer of one duplex bearer and, for the downlink transmission direction, the downlink simplex bearer of the other duplex bearer.

The release of one of the two duplex bearers composing the double duplex bearer shall cancel the link, given with the mapping procedure, between the surviving duplex bearer and the released one.



The REP\_channel\_map.req message may over-ride the T-Mux algorithm (see ETS 300 175-3 [3]), subclause 6.2.2.1) when transmitted as a first "other" message (see ETS 300 175-3[3], subclause 10.5) during a bearer setup procedure. The first response (REP\_channel\_map.confirm or wait message) shall occur in the TDMA half frame following the successful reception of the REP\_channel\_map.req from the receiving side and may also over-ride the T-Mux algorithm. The TBC shall report "bearer established" after the mapping procedure is successfully completed (i.e. the double duplex bearer has been created).

#### 6.4.1.2 REP relayed C/O connection

##### 6.4.1.2.1 IWU

The relay of a connection through REP involves, within REP, the MAC and the PHL layers, and the IWU which co-ordinates the double functionality of REP both as a PT and as an FT.

IWU shall also update the channels table and shall decide to map together duplex bearers.

Figure 15 reports a description of the IWU functionality in co-ordinating the MAC entities in REP.

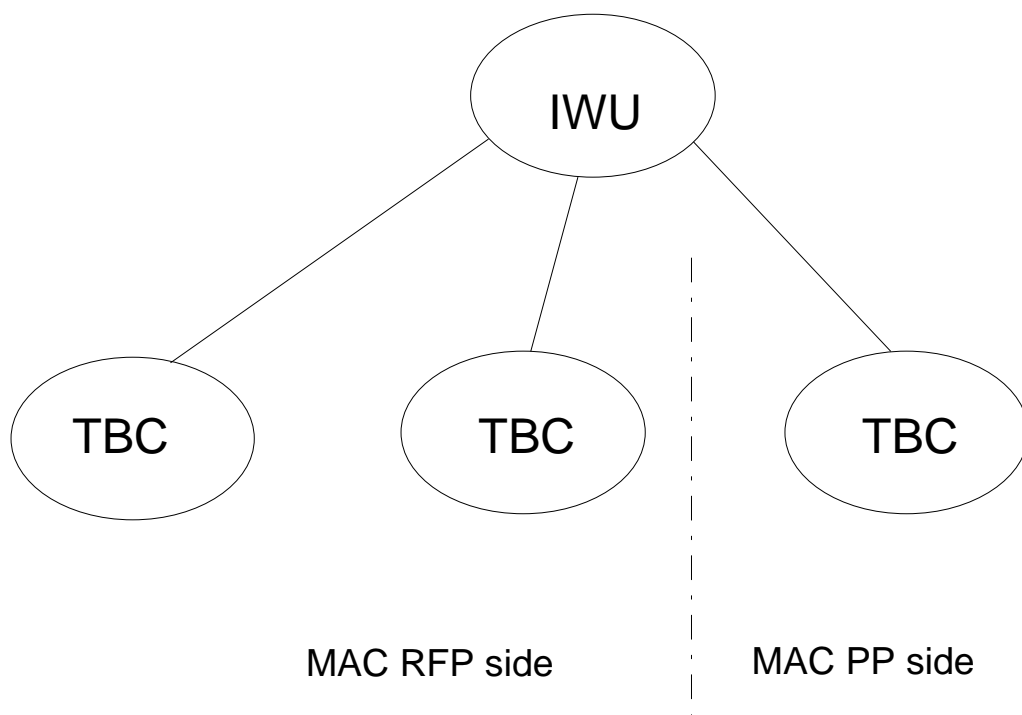

**Figure 15: IWU functionality in co-ordinating the MAC entities in REP**

On REP a new TBC is created by receiving a "bearer\_request" message, including both a calling address (PMID) and its own address (REP FMID), on the scanned physical channel. The message type also contains the information if the new bearer belongs to a basic or an advanced or a physical connection.

The TBC has then received all necessary parameters to be unambiguously identified and to identify the required service, that is:

- 1) receiving with the "bearer\_request" message either an access request or a handover request, including the calling address (PMID) and defining the connection type (i.e. advanced, basic or physical); and
- 2) for basic connection and only in case of handover request, an indication if bearer or connection handover is wanted.

The TBC issues the received parameters to IWU which can now decide:

- a) to release the TBC;
- b) to keep the TBC; and

**IF** the required connection **IS NOT** a physical connection **THEN**

```
{  
  b1) if required (refer to subclause 6.4.1.1.2 for definition), it shall initiate, towards the  
      FT (other WRS) locked to, a physical connection set-up procedure;  
  
  b2) it shall initiate towards the FT (other WRS) locked to, to set-up the relayed  
      bearer (see subclause 6.4.1.1.2 for definition);  
  
  IWU shall link together all the created TBCs as related to the same connection.  
}
```

#### 6.4.1.2.2 REP relayed C/O single duplex bearer set-up

##### Procedure:

REP receiving:

as soon as REP receives a "Bearer\_request" message error free, a TBC<sub>1</sub> is created and between REP and the sending part starts a bearer set-up procedure of the kind Basic or A-field advanced or B-field or Physical set-up (refer to subclause 6.4.1.1 and to ETS 300 175-3 [3], subclause 10.5);

**IF** it is a Basic or A-field advanced or B-field set-up and requires the set-up of new bearers for relay **THEN**

```
{  
  - REP starts, towards the FT (other WRS) locked to, a set-up procedure of the  
    same kind; if a new double duplex bearer has to be created, the first other  
    message sent by REP shall be the REP_channel_map.req (see subclause  
    6.4.1.1.3). This procedure may not be required in the case of the relayed bearer  
    (see subclause 6.4.1.1.2) is already established and does not need to be  
    handed over; and  
  
  - if a physical set-up is required (see subclause 6.4.1.1.2 for definitions), REP  
    shall complete this set up first; if a new double duplex bearer has to be created,  
    the first other message sent by REP shall be the REP_channel_map.req;  
  
  - meanwhile TBC1 sends wait messages; if the TBC1 active procedure is of kind  
    A-field advanced, the .procedure goes on up to step (8.a) of ETS 300 175-3 [3],  
    subclause 10.5.1.2;  
  
  - as soon as the set-up procedures started with the FT (other WRS) locked to are  
    successfully terminated (i.e. the involved TBCs report "bearer_established");  
  
  - TBC1 sends bearer_confirm (or attributes_confirm if the active set-up procedure  
    is an A-field advanced).  
}
```

For each further duplex bearer to be relayed, the procedure is repeated.

Figures 17 and 18 show examples of relayed basic bearer set-ups.

#### 6.4.1.2.3 REP relayed C/O bearer release

The release of a bearer which belongs to a REP relayed connection, implies the release of all the bearers which have been set up to relay the connection.

In case of unacknowledged release procedure (see ETS 300 175-3 [3], subclause 10.7.2.1) of a bearer which has been mapped to another bearer (see subclause 6.4.1.1.3):

at the REP as transmitting side:

the radio channel and the associated TBC shall not be released after sending the RELEASE messages, if it is the MBC's decision to release the bearer and if the channel is also interlaced with another channel (see subclause 6.4.1.1.3 for definitions).

at the REP as receiving side:

the radio channel and the associated TBC shall not be released after successful receiving of a RELEASE message if the channel is also interlaced with another channel.

#### 6.4.1.2.4 REP relayed C/O bearer handover

Bearer handover procedures may be used to perform:

- 1) intra-cell handover of the PT within REP;
- 2) intra-cell handover of the REP within one RFP;
- 3) inter-cell handover of the REP from one RFP to an RFP belonging to the same cluster;
- 4) inter-cell handover of the PT from a REP to an RFP belonging to the same cluster;
- 5) inter-cell handover of the PT from an RFP to a REP belonging to the same cluster;
- 6) inter-cell handover of the PT from one REP to a REP belonging to the same cluster;
- 7) inter-cell handover of one REP to another WRS belonging to the same cluster.

REP can be defined as a separate cluster or as part of the cluster of the RFP(s) that it is locked to.

These handover procedures are handled as follows:

- 1) completely handled at REP as an FT (example in figure 25);
- 2) handled between REP and the FT (other WRS), with the procedure described in subclause 6.4.1.2.2 (example in figure 26);
- 3) as for 2);
- 4) completely handled at FT (examples in figures 27 and 28);
- 5) as for 2);
- 6) as for 2);
- 7) as for 2).

## 6.4.2 DLC layer

### 6.4.2.1 REP relayed C/O connection handover

Connection handover procedures may be used to perform:

- 1) handover of REP from an RFP (or REP or CRFP) to another RFP (or REP or CRFP);
- 2) handover of the PT from a REP to an RFP;
- 3) handover of the PT from an RFP to a REP;
- 4) handover of the PT from a REP to another REP.

These handover procedures are handled as follow:

- 1) completely handled at REP as a PT;
- 2) completely handled at RFP;
- 3, 4) handled between REP and RFP (other WRS) with the same procedure described in subclause 6.4.1.2.2.

## 6.4.3 Management

### 6.4.3.1 REP states

REP combines states of both an FT and a PT, as defined in ETS 300 175-3 [3].

The diagram of figure 16 reports the transitions between all the allowed REP states.

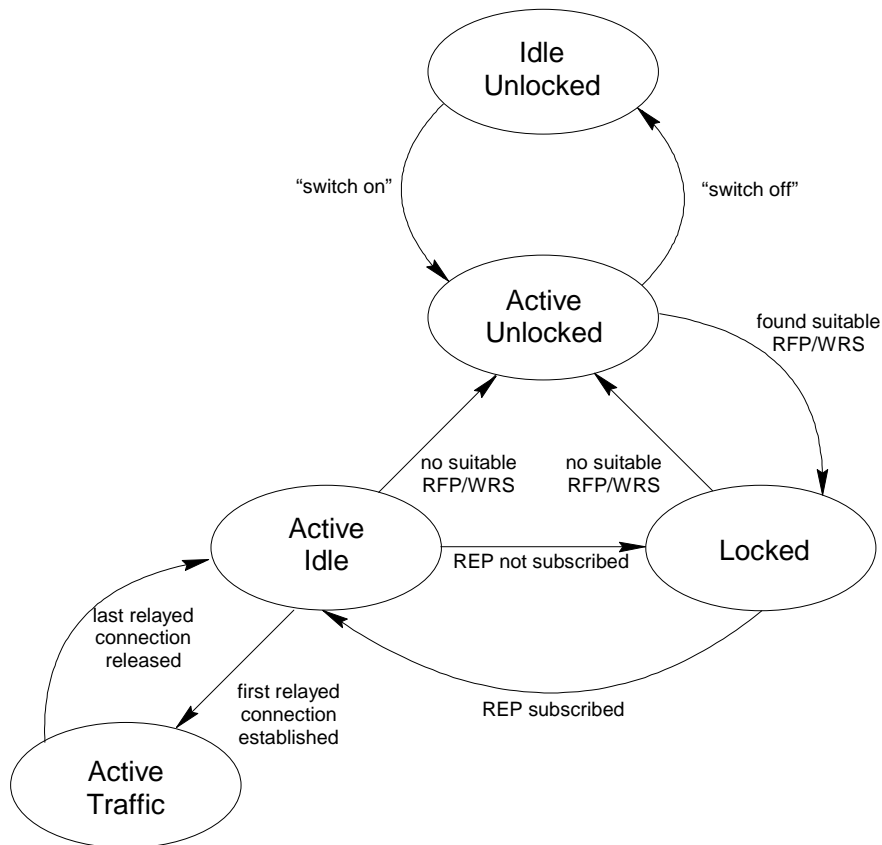

Figure 16: REP state diagram

- 1) Idle\_Unlocked: where the REP is not synchronized and does not attempt to get synchronized to an RFP or WRS. In this state REP is not receiving nor transmitting.
- 2) Active\_Unlocked: where the REP is not synchronized to any RFP or WRS and is unable to make/receive direct connections, or to relay connections. REP makes attempts to detect a suitable RFP or another WRS and enter the Locked state.
- 3) Locked: where the REP is synchronized to at least one RFP or WRS. It is able to make/receive direct connections, and may have direct connections in progress, but it is still unable to relay connections.
- 4) Active\_Idle: where the REP has been subscribed to the system and has received a consistent MAC identity. The REP has either at least one dummy bearer or at least one connectionless downlink bearer, and a receiver that is scanning the physical channels in a known sequence. In this state REP is able to make/receive direct connections and to relay connections, but has no relayed connection in progress.
- 5) Active\_Traffic: where REP relays at least one connection. In this state REP can have direct connections in progress and may have a dummy or connectionless downlink bearer.

#### **6.4.3.2 REP actions and states transitions**

##### **6.4.3.2.1 Actions in the Idle\_Unlocked and Active\_Unlocked states**

In the Idle\_Unlocked state, REP shall do nothing.

In the Active\_Unlocked state, REP tries to get synchronized to a suitable RFP or other WRS and enter the Locked state, with the same modality as described in ETS 300 175-3 [3] subclause 11.3.2, where a DECT FP can be either an FT or another WRS.

##### **6.4.3.2.2 Actions in the Locked state**

In the Locked state, REP shall maintain frame and multiframe synchronism with the FP or other WRS and may occasionally scan for RFPs (WRSs) with a stronger signal strength. If a stronger RFP (WRS) is found, then the REP may lock to this RFP (WRS) instead.

In order to remain in the Locked state the REP shall:

- re-synchronize its timing with the FPs (WRSs) timing at least every T216 multiframe (refer to ETS 300 175-2 [2]);
- receive in frame 0 at least one A-field with correct CRC every T207 seconds; and
- receive at least one N<sub>T</sub> type tail containing the PARI every T208 seconds.

If any of these conditions is not met, REP shall enter the Active\_Unlocked state.

At any time REP can leave the Locked state and enter the Active\_Unlocked state.

Once REP has been subscribed to the system, it enters the Active\_Idle state.

##### **6.4.3.2.3 Entry into the Active\_Idle state**

Once REP has been subscribed to the system, it enters the Active\_Idle state.

#### 6.4.3.2.4 Actions in the Active\_Idle state

In the Active\_Idle state, REP shall:

- still get synchronized to an RFP (WRS) as it does in the Locked state;
- broadcast in downlink direction the N channel information with its own RPN value, assigned in the subscription phase onto an established dummy or connectionless downlink bearer;
- broadcast in downlink direction the Q channel information onto an established dummy or connectionless downlink bearer.

The fixed part capabilities system information i.e. SARI list contents system information and multi-frame number system information, shall reflect the same system information broadcast by the RFP (WRS) locked to. It shall also reflect its own extended fixed part capabilities system information to control the number of allowed cascaded REPs, if this information is broadcast by the RFP (other WRS) locked and the number of allowed HOPS is greater than 0. It shall answer to the paging messages referring to itself and broadcast in the downlink direction the not referring ones onto an established dummy or connectionless downlink bearer.

REP shall fill out the MAC layer information field both of short and of zero length page messages with its own MAC information and shall fill out the 20 least significant bits of RFPI field within zero length page messages with its RFPI value.

At any time an Active\_Idle state REP may leave this state and enter the Active\_Unlocked state, as soon as the synchronism gets lost.

In Active\_Idle state, REP shall receive all the RFP (WRS) locked to broadcast messages.

#### 6.4.3.2.5 Entry into the Active\_Traffic state

REP enters the Active\_Traffic state at the first relayed connection.

#### 6.4.3.2.6 Actions in the Active\_Traffic state

In the Active\_Traffic state REP shall do the same actions as in Active\_Idle state and shall relay at least one connection.

#### 6.4.3.3 Channel selection

Once in one of the states, i.e. Active\_Idle or in Active\_Traffic or in Active\_Locked, REP may start transmission on a physical channel according to ETS 300 175-3 [3], subclause 11.4 with the following additions:

- a) double duplex bearers:

for setting up in uplink direction a double duplex bearer, it is required to relay one duplex bearer PP connection or another double duplex bearer REP connection:

said  $((y;y+12);f_y)$  and  $((z;z+12);f_z)$  the duplex bearers pair composing the double duplex bearer set-up by REP and, respectively  $((x;x+12);f_x)$  the REP relayed duplex bearer or  $((x_1;x_1+12);f_{x_1})$  and  $((x_2;x_2+12);f_{x_2})$  the REP relayed duplex bearers pair composing the double duplex. For each duplex bearer to be set-up the following further restriction has to be respected:

$$\begin{aligned} 0 &\leq Y < X && \text{(where } X = \min(X_1; X_2)\text{); and} \\ X &< Z \leq 11 && \text{(where } X = \max(X_1; X_2)\text{).} \end{aligned}$$

b) double simplex bearer:

said (x;x+12) the double simplex bearer to be REP relayed, and (y;y+12) the relayed double simplex bearer to be set up by REP, the following further restriction has to be respected:

$$Y > X.$$

### 6.5 Example operation of REP

This subclause contains example time-message diagrams for a REP relayed basic connections.

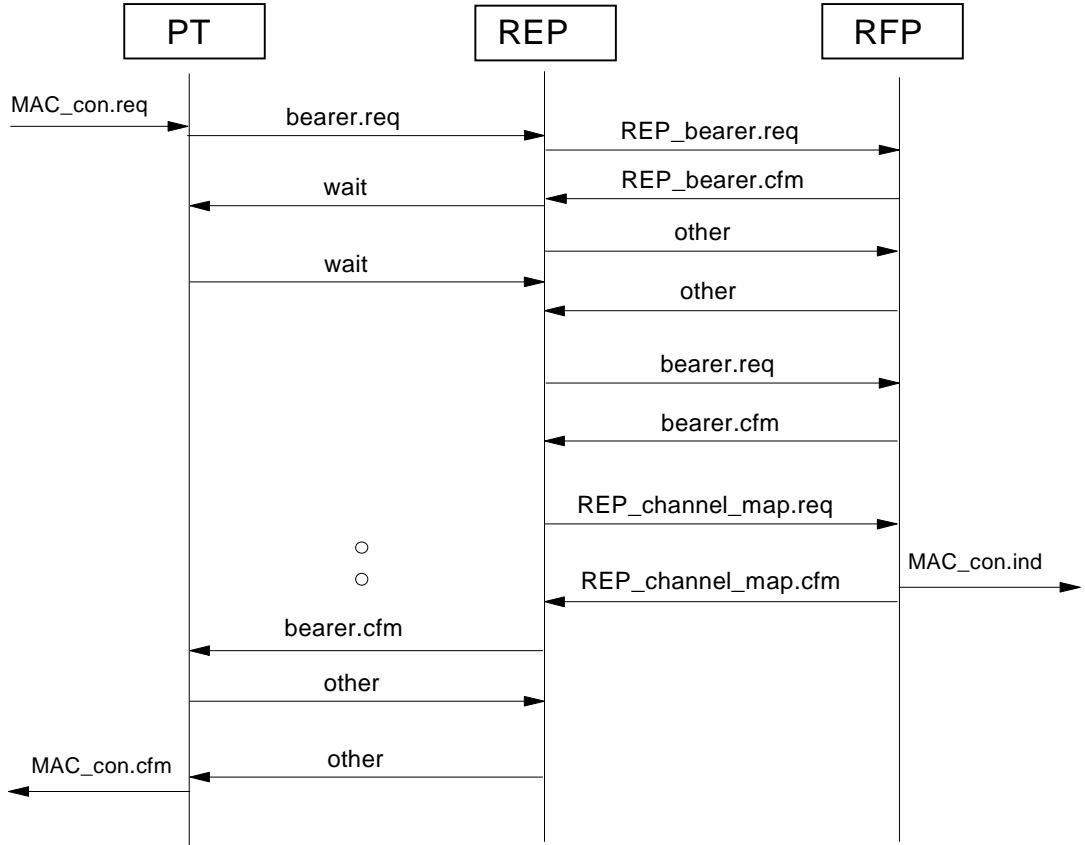

Figure 17: Bearer set-up scenario

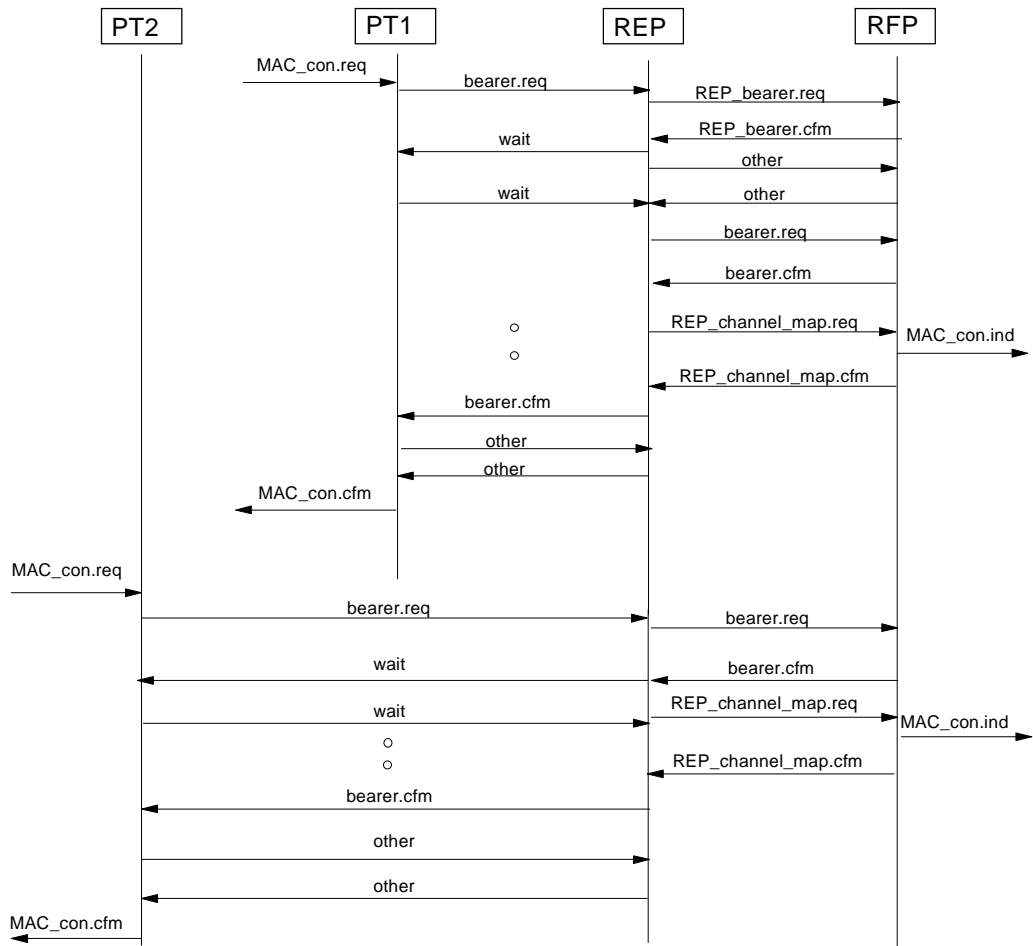

Figure 18: Interlaced bearer set-up scenario

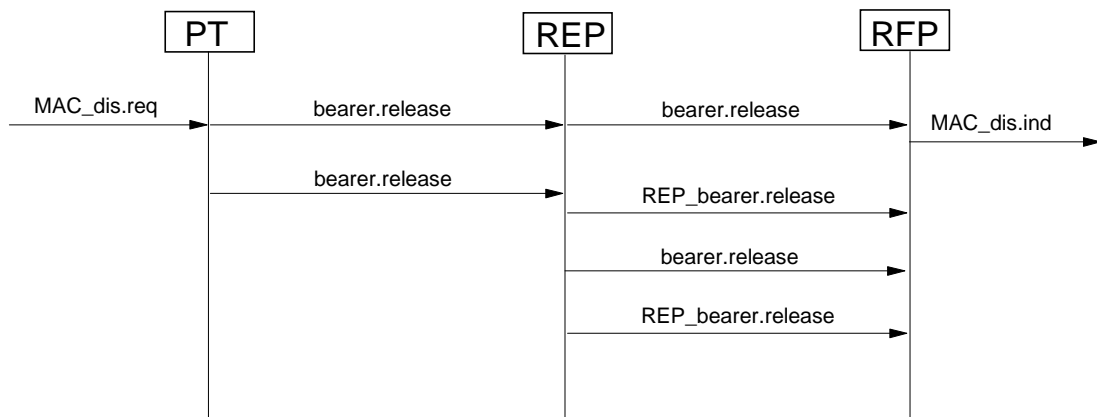

Figure 19: PP initiated bearer release scenario



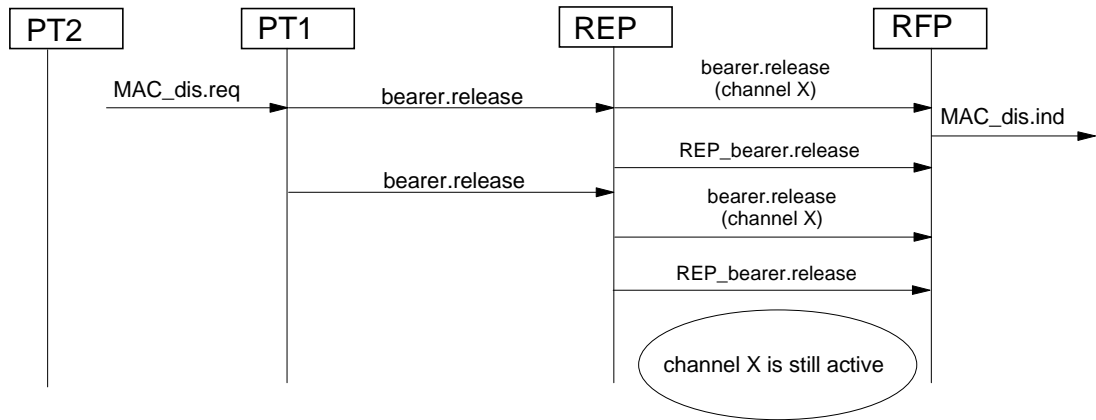

Figure 20: PP initiated interlaced bearer release scenario

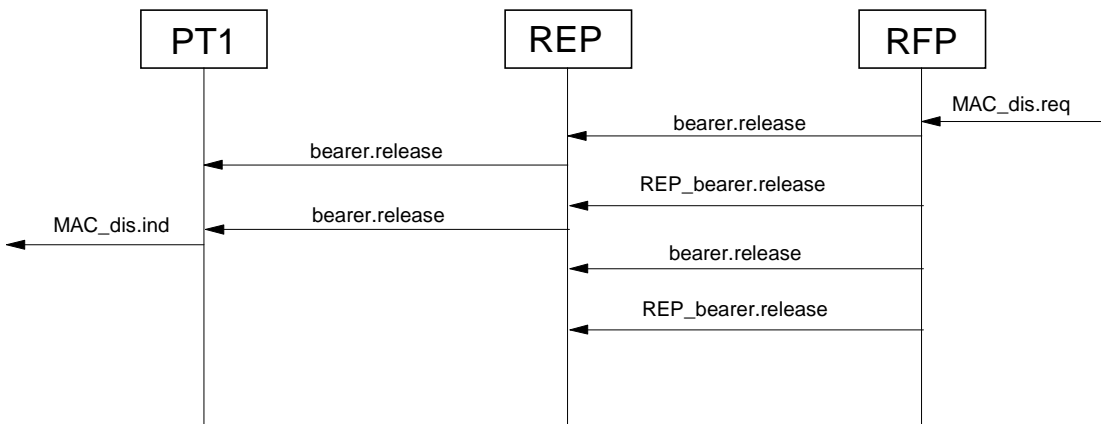

Figure 21: FP initiated bearer release scenario

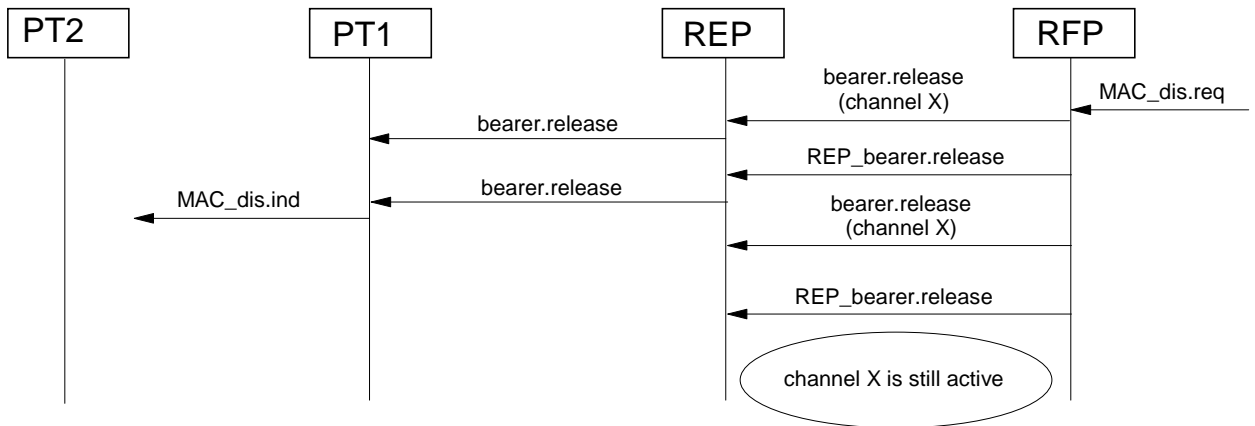

Figure 22: FP initiated interlaced bearer release scenario

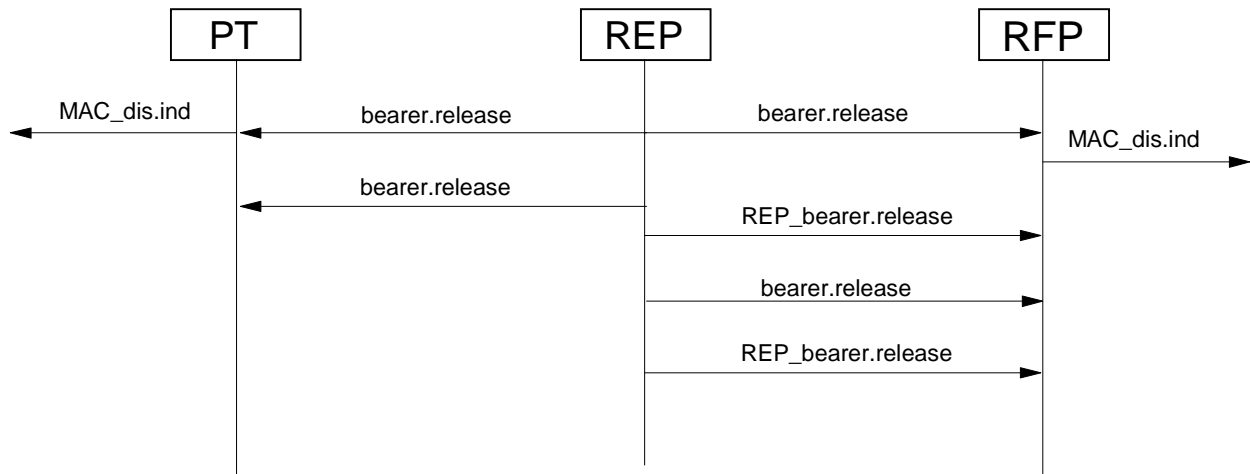

Figure 23: REP initiated bearer release scenario

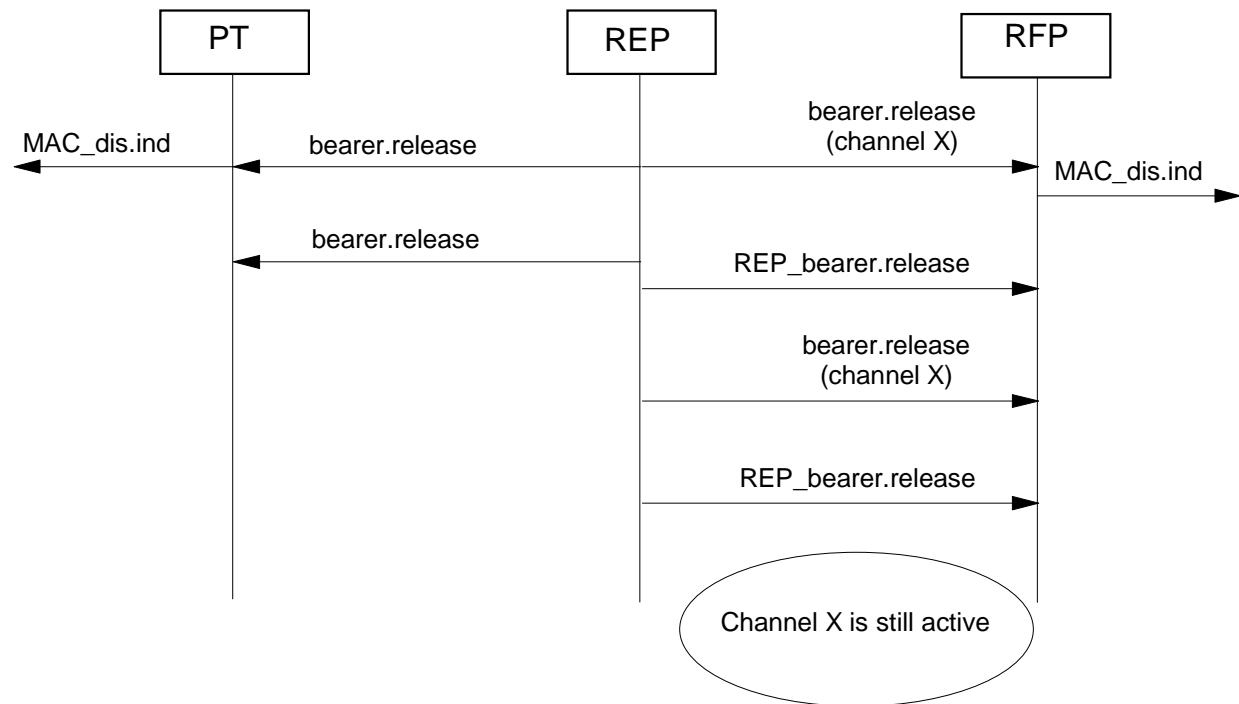
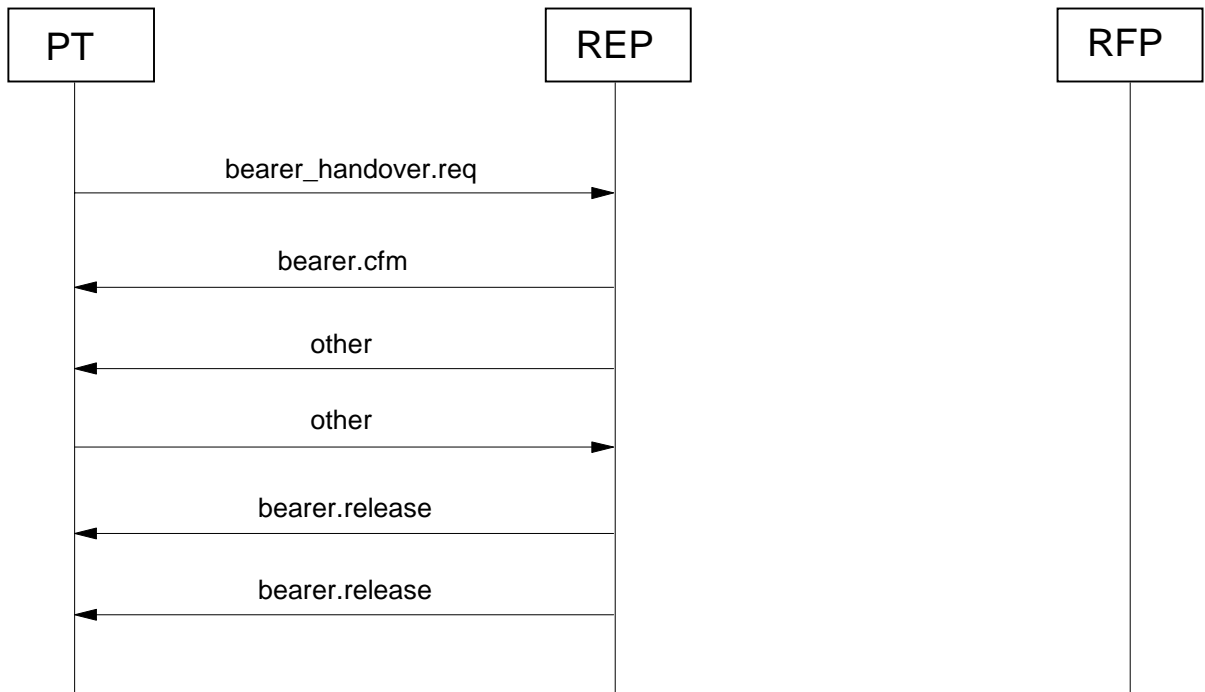

Figure 24: REP initiated interlaced bearer release scenario



**Figure 25: PP-REP bearer handover scenario; the new PP-REP set-up bearer still lies between the two REP-RFP established channels (subclause 6.4.4.3 is still fulfilled)**

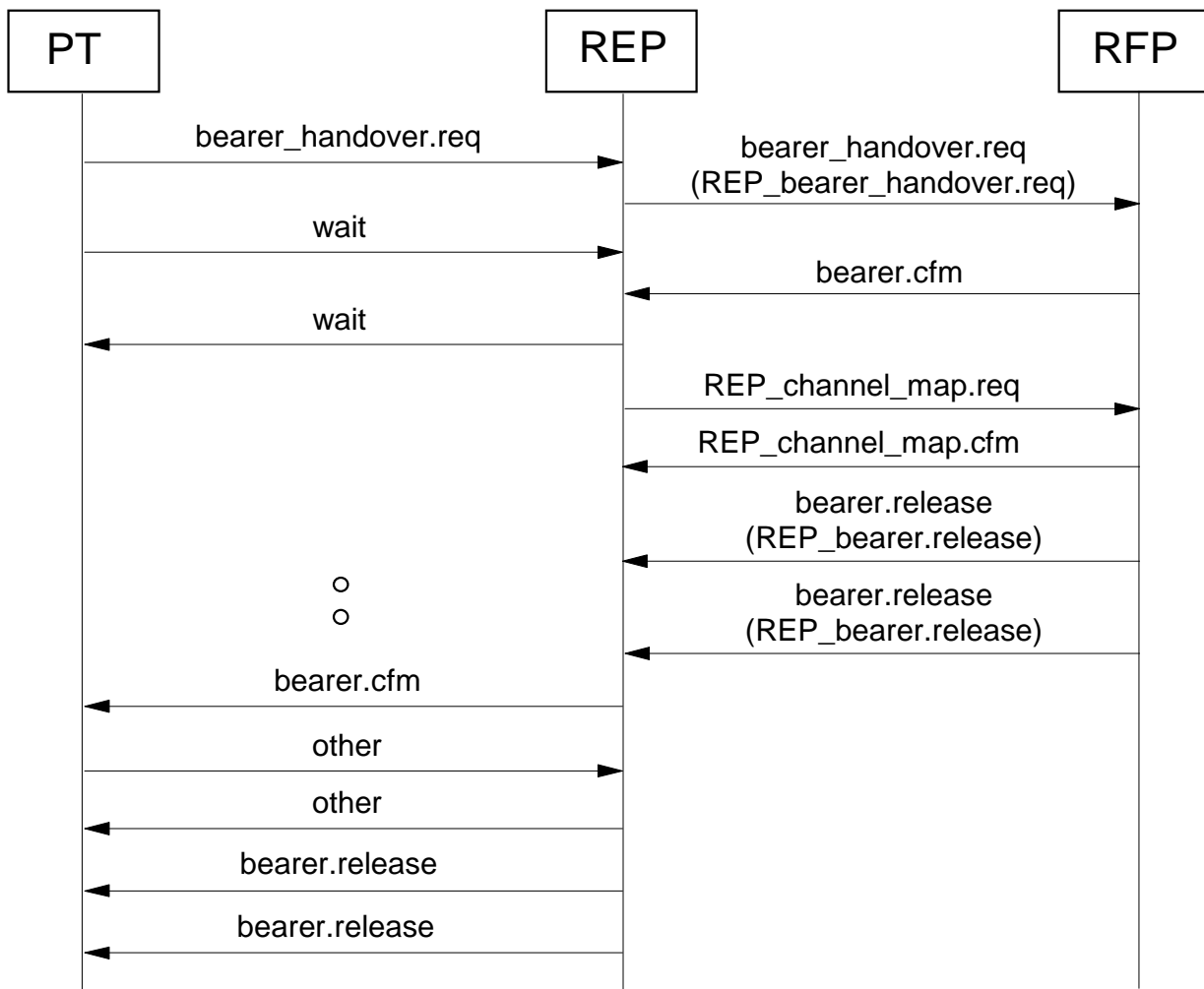

Figure 26: PP-REP bearer handover scenario; a REP-RFP bearer handover is required (i.e. subclause 6.4.4.3 is no longer fulfilled)

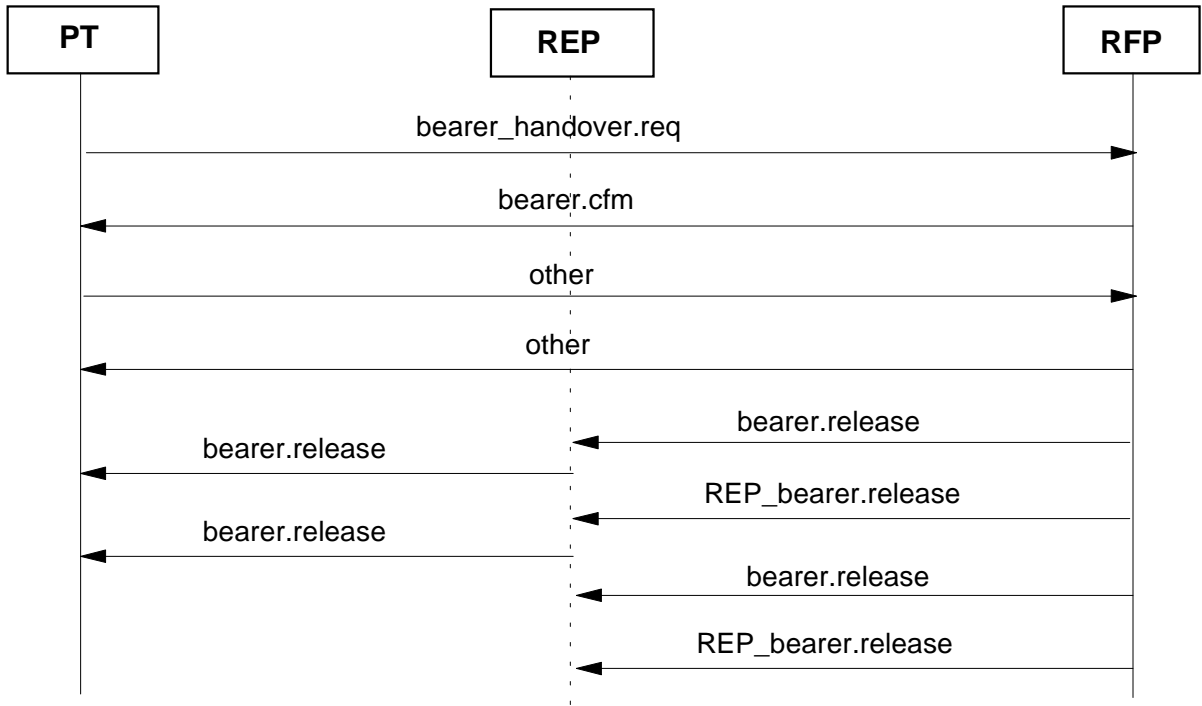

Figure 27: PP-RFP basic bearer handover scenario

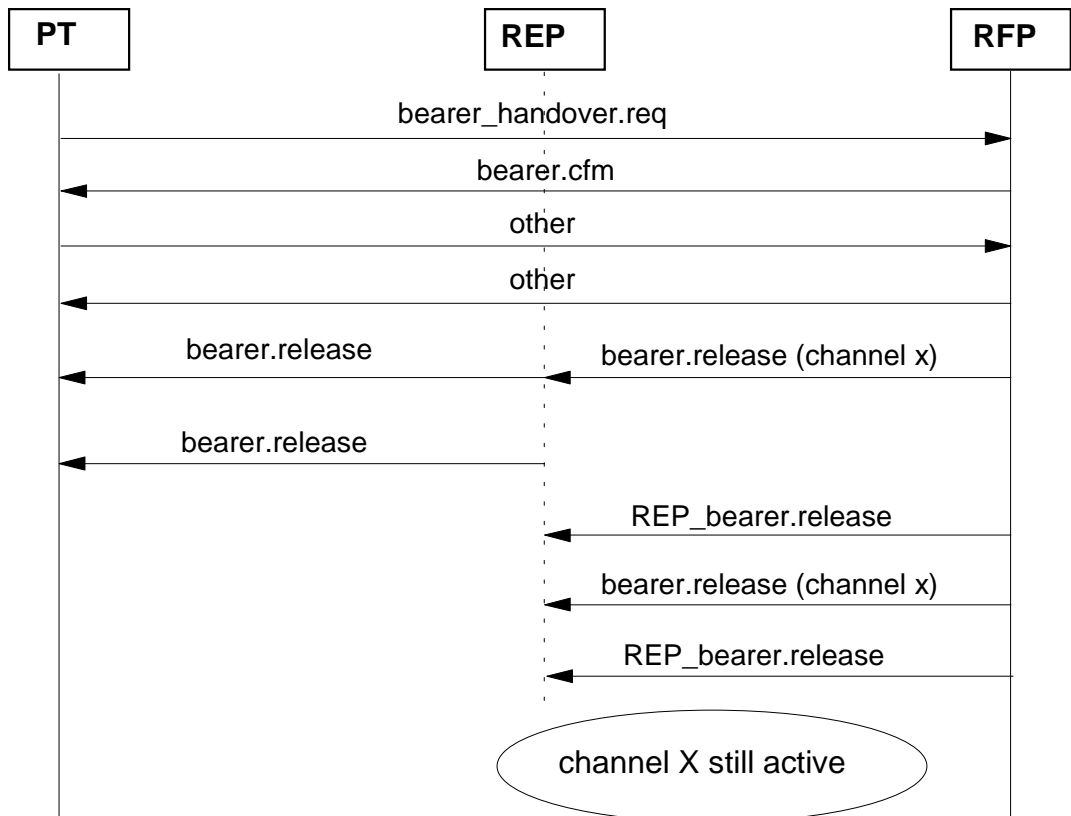

Figure 28: PP-RFP interlaced bearer handover scenario

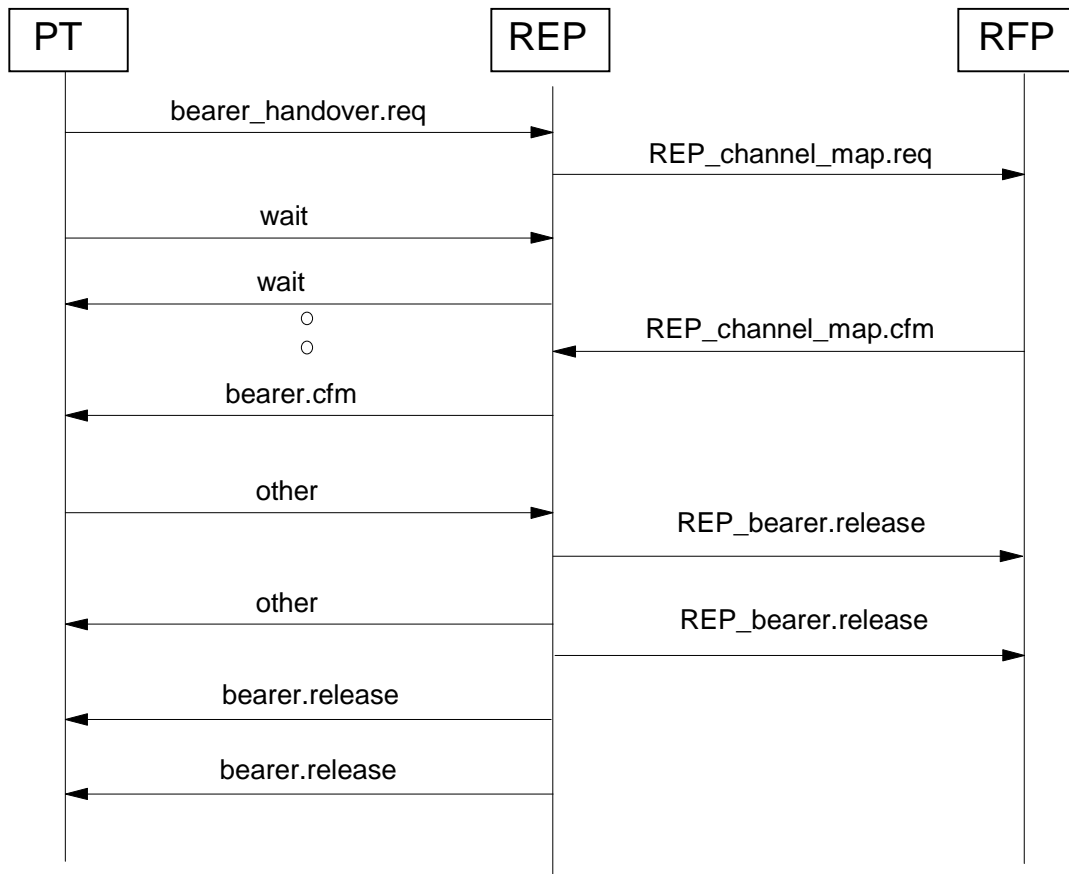

Figure 29: PP-REP bearer handover scenario; the new set-up bearer allows the interlacing with an existing bearer

## Annex A (normative): The optional CRFP interface to REP

This ANNEX defines optional requirements to the CRFP which allow a CRFP to interface to a REP. These requirements specify the optional CRFP feature "**REP interface**".

The CRFP provided with this enhanced interface may perform an adapter function between an FT supporting a CRFP interface, and a REP, in a multihop WRS chain.

### A.1 Description

#### A.1.1 General

The CRFP with the optional "REP interface" shall fulfil - in addition to the requirements to the CRFP in clause 5 - the requirements to an FT stated in subclause 6.1.2 and in ETS 300 175-3 [3], to support the REP in place of the PT. This means that the CRFP\_FT will be able to communicate to a REP\_PT.

#### A.1.2 Frame multiplexing structure

When performing the adapter function between an FT (or CRFP) and the REP, the CRFP shall perform a mapping between a REP double duplex bearer at the FT side and a duplex bearer at the PT side. This support of a duplex bearer and a double duplex bearer in parallel results in a frame multiplexing structure which combines the CRFP (see subclause 5.1.3.2) and the REP (see subclause 6.1.3.2) frame multiplexing structure.

Figure A.1 shows an example of the frame structure at the CRFP within a two-hop WRS chain built with a CRFP and a REP.

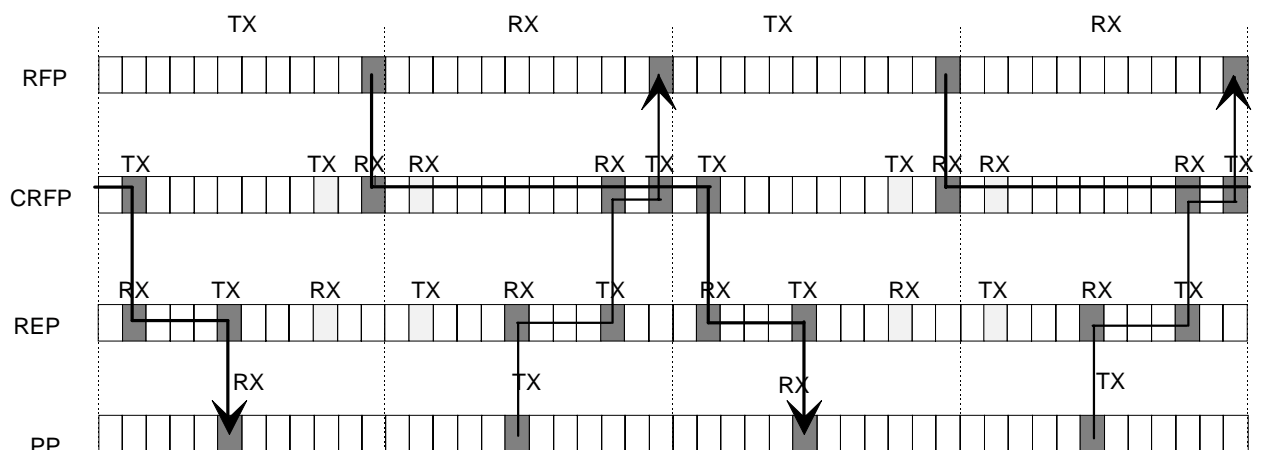

**Figure A.1: Example of frame multiplexing structure in a chain of a CRFP and a REP**

NOTE 1: The minimum incremental round-trip delay for B-field user data caused by a mixed-type WRS chain of one CRFP and one or more REPs is one DECT frame (10 ms) if the bearer allocation rule of subclause A.3.2 is applied by the CRFP and two DECT frames (20 ms) otherwise. Even in the latter case, the delay is not more than that of a 2 hop CRFP chain.

NOTE 2: For a 2 hop WRS chain composed by a REP cascaded to a CRFP, the maximum number of offered connections (full slot duplex bearers) by the last hop of the chain is 4. This corresponds to 0.85 E at the Grade of Service (GoS) 0,5 %. Under the same assumptions, the maximum number of connections cleared by the last hop of a 2 hop CRFP chain is 6, which corresponds to 1.5 E.

## A.2 Messages

### A.2.1 MAC layer

When interfacing to a REP, the CRFP shall use the MAC messages defined for REP at the interface between CRFP and REP. At the interfaces to other units (FT, CRFP, PP) the MAC messages required by CRFP shall be used.

### A.2.2 Hop control

The FP can allow chains of WRSs of the same or different type by means of the extended fixed part capabilities message (see subclause 4.4.2.1) and may control the WRS attachment by means of the  $a_{13}$  bit of the Physical and MAC layer capabilities in the fixed part capabilities message (see ETS 300 175-3 [3]).

## A.3 Procedures

### A.3.1 MAC layer

When interfacing a REP, the CRFP shall use the procedures defined for REP, and when interfacing the FT (or CRFP) it shall still use the procedures required by CRFP.

Figure A.2 shows an example of time-messages diagram exchanged to establish a Basic connection between an FT and a PT, through a two hops chain of a CRFP and a REP. Figure A.3 widens the example for the case of encryption supported.

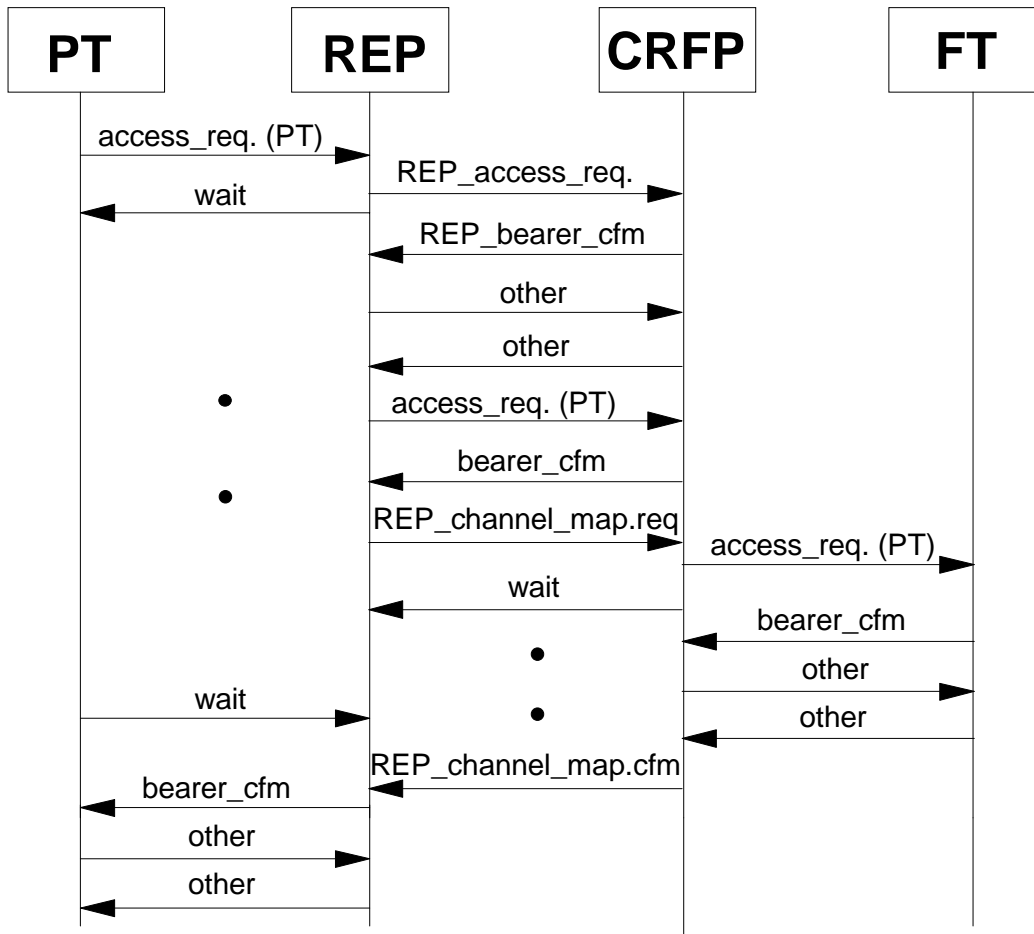

Figure A.2: Example of basic bearer set-up through a chain of CRFP and REP



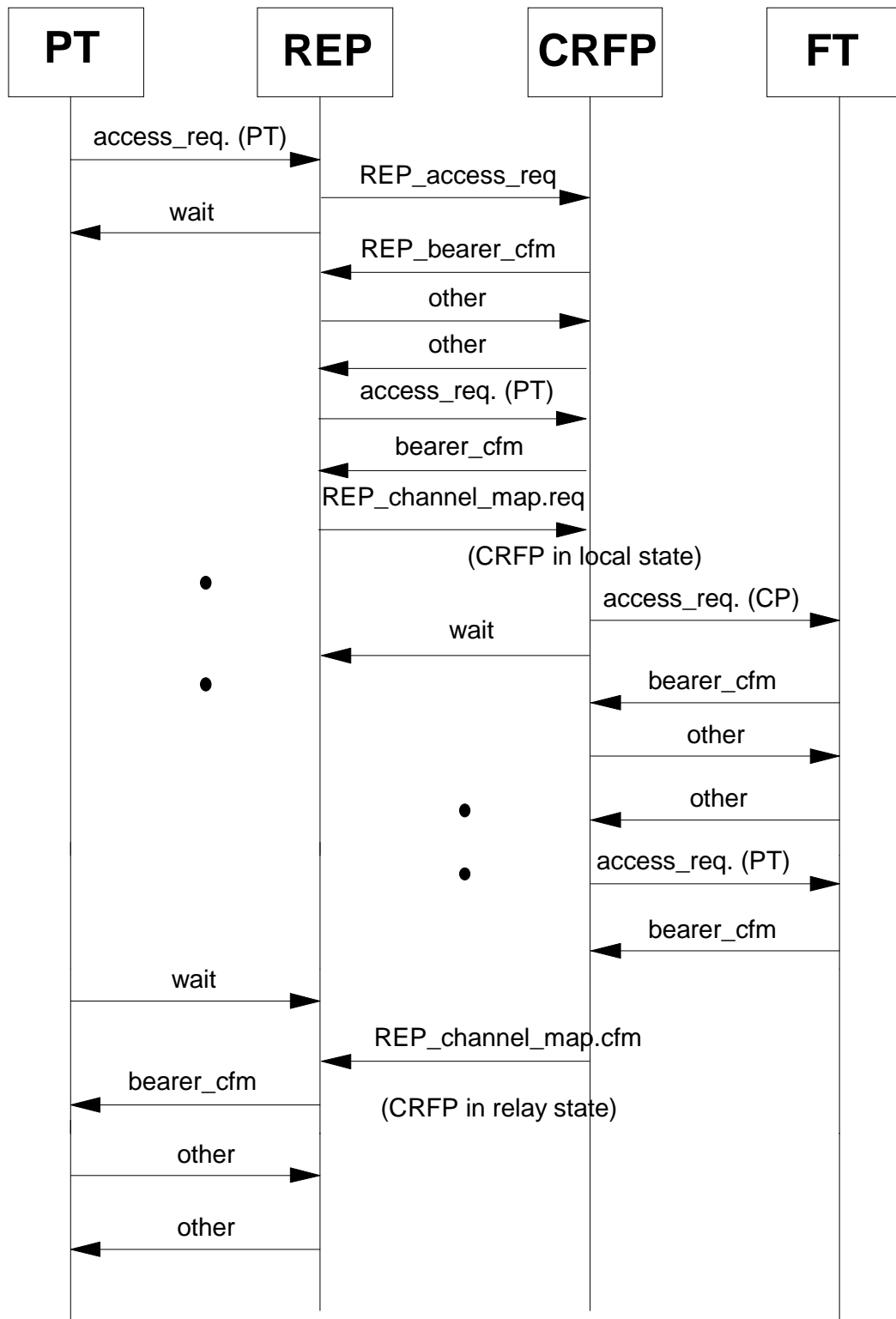

Figure A.3: Example of basic bearer set-up through a chain of CRFP and REP, when encryption is supported

### A.3.2 Channel selection

In principle, the bearer positions at the CRFP\_PT side and the CRFP\_FT side to relay a connection are independent from each other except that the bearer positions (time slots) at the PT side and the FT side can not be identical. This also holds for the case where the CRFP interfaces to a REP, and REP double duplex bearers are used at the CRFP\_FT side which are interworked to single duplex bearers at the CRFP\_PT side.

However in the latter case the incremental round-trip delay depends on the relative positions of the double duplex bearers and the single duplex bearers. The delay is reduced by one DECT frame if the following condition is met.

Let  $(x_1; x_1+12)$  and  $(x_2; x_2+12)$  be the two time slot pairs of a double duplex bearer at the REP-CRFP interface (with  $0 \leq x_1 < x_2 \leq 11$ ), and  $(y; y+12)$  with  $0 \leq y \leq 11$  be the time slot pair of the associated (single) duplex bearer to be established at the CRFP-FT interface, then the following restriction to obtain minimum delay applies:

$$(y < x_1) \text{ OR } (y > x_2)$$

This means that the duplex bearer should be positioned **outside the interval**  $(x_1, x_2)$  spanned by the double duplex bearer, either to the left of (before) or to the right of (behind) the interval, to achieve the delay reduction indicated in subclause A.1.3.

**Annex B (normative): ETS 300 175 changes**

**B.1 Modifications to MAC layer specification, ETS 300 175-3**

**B.1.1 Modifications to subclause 7.1.4**

Subclause 7.1.4 should be modified as follows:

These bits describe the contents of the B-field that follows the A-field. See table 10 below.

**Table 10**

<b>a<sub>4</sub></b>	<b>a<sub>5</sub></b>	<b>a<sub>6</sub></b>	<b>B-Field Contents</b>
0	0	0	U-type, I <sub>N</sub> , SI <sub>N</sub> or I <sub>P</sub> packet number 0 or no valid I <sub>P</sub> error detect channel data
0	0	1	U-type, I <sub>P</sub> error detect or I <sub>P</sub> packet number 1 or SI <sub>P</sub> or no valid I <sub>N</sub> channel data
0	1	0	E-type, all C <sub>F</sub> or CL <sub>F</sub> , packet number 0
0	1	0	double slot required
0	1	1	E-type, all C <sub>F</sub> , packet number 1
1	0	0	E-type, not all C <sub>F</sub> or CL <sub>F</sub> ; C <sub>F</sub> packet number 0
1	0	0	half slot required
1	0	1	E-type, not all C <sub>F</sub> ; C <sub>F</sub> packet number 1
1	1	0	E-type, all MAC control (unnumbered)
1	1	1	no B-field
NOTE 1:			The 000 code may be used to indicate that the B-field does not contain valid data, only for an already established I <sub>P</sub> error detect connection.
NOTE 2:			The 001 code may be used to indicate that the B-field does not contain valid data, only for an already established I <sub>N</sub> connection.

NOTE: Testing of this H-field with all possible T- and B-fields is not intended. A manufacturer's declaration is appropriate.

In relation to a BEARER\_REQUEST message of the A-field advanced connection control set and REP connection control set, the a<sub>4</sub>, a<sub>5</sub>, a<sub>6</sub> bits shall indicate the following:

010: "double slot required", B-field does not contain valid logical channel data.

100: "half slot required", B-field does not contain valid logical channel data.

The first response from the called side shall use the same BA bits setting used by the calling side and the B-field does not contain valid logical channel data. In the following messages, the BA bits shall indicate the logical channels contained in the B-field.

In relation to a BEARER\_REQUEST message of the A-field advanced connection control set and REP connection control set, all other codings shall indicate full slot with the B-field contents described above.

**B.1.2 Modifications to subclause 7.2.3.4.2**

Subclause 7.2.3.4.2 should be modified as follows:

**7.2.3.4.2 Standard capabilities**

0011	Physical and MAC layer capabilities	Higher layer information
a <sub>8</sub> - a <sub>11</sub>	a <sub>12</sub> - a <sub>31</sub>	a <sub>32</sub> - a <sub>47</sub>

**Figure 33**

**Physical and MAC layer capabilities available:**

If a capability is available:

then bit a<sub>x</sub> shall be set to 1;  
 else (capability is not available) the bit a<sub>x</sub> shall be set to 0.

Reserved bits shall be set to 0.

**Table 22**

bit number	Capability
a <sub>12</sub>	extended FP information (QH = 4)
a <sub>13</sub>	double duplex bearer connection
a <sub>14</sub>	reserved
a <sub>15</sub>	double slot
a <sub>16</sub>	half slot
a <sub>17</sub>	full slot
a <sub>18</sub>	frequency control
a <sub>19</sub>	page repetition
a <sub>20</sub>	C/O setup on dummy allowed
a <sub>21</sub>	C/L uplink
a <sub>22</sub>	C/L downlink
a <sub>23</sub>	basic A-field set up
a <sub>24</sub>	advanced A-field set up
a <sub>25</sub>	B-field set up
a <sub>26</sub>	CF messages
a <sub>27</sub>	IN_minimum_delay
a <sub>28</sub>	IN_normal_delay
a <sub>29</sub>	IP_error_detection
a <sub>30</sub>	IP_error_correction
a <sub>31</sub>	multibearer connections
NOTE 1:	Bit a <sub>19</sub> indicates whether or not Idle_Locked PPs may enter the low duty cycle Idle_Locked mode (see subclause 11.3.3.1).
NOTE 2:	The bits a <sub>21</sub> and a <sub>22</sub> indicate only the capabilities of the FT to provide connectionless services in the uplink or downlink direction. They do not indicate if these services are active when the message is transmitted.

**Higher layer information:**

The management entity in the fixed part supplies the MAC layer with a 16 bit SDU via the ME SAP. At the PT the MAC layer passes the 16 bits out through the ME SAP to the management entity.

For the setting of the higher layer information bits refer to annex F of ETS 300 175-5 [4].

### **B.1.3 Modifications to subclause 10.5.1.1**

In relation to subclause 5.3.4.1 of this ETS, the following note is added to subclause 10.5.1.1:

NOTE 5: During bearer handover and connection handover with encryption from a RFP to a CRFP it is allowed that the FT and CRFP exchange higher layer messages and start messages between the  $M_T$  bearer\_handover.req message (PT PMID) and the  $M_T$  bearer.cfm message.

### **B.1.4 Modifications to subclause 10.5.1.2.1**

In relation to subclause 5.3.4.1 of this ETS, the following note is added to subclause 10.5.1.2.1:

NOTE 4: During bearer handover and connection handover with encryption from a RFP to a CRFP it is allowed that the FT and CRFP exchange higher layer messages and start messages between the  $M_T$  bearer\_handover.req message (PT PMID) and the  $M_T$  bearer.cfm message.

### **B.1.5 Modifications to subclause 10.5.1.3.1**

In relation to subclause 5.3.4.1 of this ETS, the following note is added to subclause 10.5.1.3.1:

NOTE 6: During bearer handover and connection handover with encryption from a RFP to a CRFP it is allowed that the FT and CRFP exchange higher layer messages and start messages between the  $M_T$  bearer\_handover.req message (PT PMID) and the  $M_T$  bearer.cfm message.

## **B.2 Modifications to NWK layer specification, ETS 300 175-5**

For transferring the RPN to the WRS, the Fixed Identity information element with identity type 'ARI + RPN for WRS' should be used.

### **B.2.1 Modifications to subclause 7.7.18**

Subclause 7.7.18 should be modified as follows:

Add a new value for Type Coding (octet 3):

"0000010 Access rights identity plus radio fixed part number for WRS".

Add the following note to the paragraph for Radio Fixed Part Number (RPN) (octet L+2):

NOTE: For Identity type 'ARI + RPN for WRS' the RPN shall be the RPN of the WRS.

## History

Document history			
March 1996	Public Enquiry	PE 103:	1996-03-04 to 1996-06-28
December 1996	Vote	V 117:	1996-12-23 to 1997-02-14
March 1997	First Edition		