



INTERIM
EUROPEAN
TELECOMMUNICATION
STANDARD

FINAL DRAFT
pr I-ETS 300 697-4

December 1997

Source: TE

Reference: DI/TE-02028-5

ICS: 33.020

Key words: ISDN, access, ATS, network, PCI, testing

**Integrated Services Digital Network (ISDN);
Conformance testing for the Euro-ISDN Programming
Communication Interface (PCI);
Part 4: Abstract Test Suite (ATS) specification
for the Network Access Facility (NAF)**

ETSI

European Telecommunications Standards Institute

ETSI Secretariat

Postal address: F-06921 Sophia Antipolis CEDEX - FRANCE

Office address: 650 Route des Lucioles - Sophia Antipolis - Valbonne - FRANCE

X.400: c=fr, a=atlas, p=etsi, s=secretariat - **Internet:** secretariat@etsi.fr

Tel.: +33 4 92 94 42 00 - Fax: +33 4 93 65 47 16

Copyright Notification: No part may be reproduced except as authorized by written permission. The copyright and the foregoing restriction extend to reproduction in all media.

© European Telecommunications Standards Institute 1997. All rights reserved.

Contents

Foreword	5
Introduction	5
1 Scope	7
2 References	7
3 Definitions and abbreviations	8
3.1 Definitions	8
3.2 Abbreviations	8
4 Status	8
5 General constraints for testing and applicable test method	9
5.1 Testing Model	9
5.2 Test method for PCI messages and Exchange Mechanism	9
5.3 Testing configuration	10
5.4 Mapping of PCI concepts into TTCN terms	11
5.4.1 Exchange Mechanism functions	11
5.4.2 ISDN PCI messages	11
6 ATS naming conventions	11
7 Notes on the ATS	12
7.1 Encoding of ISDN message Information Elements (IEs)	12
7.2 Naming ISDN messages constraints	13
7.3 Test Purposes grouping into a combined TP	13
7.4 Order of parameters	13
8 Test Purpose to Test Case mapping	13
Annex A (normative): Abstract Test Suite for the ETS 300 325 NAF	14
A.1 The TTCN Graphical form (TTCN.GR)	14
A.2 The TTCN Machine Processable form (TTCN.MP)	14
Annex B (normative): PCTR for the ETS 300 325 NAF	15
B.1 Identification summary	15
B.1.1 Protocol Conformance Test Report	15
B.1.2 IUT	15
B.1.3 Testing environment	16
B.1.4 Limits and reservations	16
B.1.5 Comments	16
B.2 IUT conformance status	16
B.3 Static conformance summary	16
B.4 Dynamic conformance summary	16
B.5 Static conformance review report	17
B.6 Test campaign report	17

B.7	Observations.....	24
Annex C (normative): Partial IXIT proforma for the ETS 300 325 NAF		25
C.1	Identification summary.....	25
C.2	Abstract Test Suite summary	25
C.3	Test laboratory.....	25
C.4	Client.....	25
C.5	SUT.....	25
C.6	Protocol information for the ETS 300 325 NAF	26
C.6.1	Protocol identification	26
C.6.2	IUT information.....	26
Annex D (informative): ETS 300 325 NAF PCI ICS Proforma.....		29
D.1	Instructions for completing the NAF PCI ICS proforma.....	29
D.1.1	Purposes and structure	29
D.1.2	Conventions	30
D.1.2.1	Standardized symbols for the status column.....	30
D.1.2.2	Standardized symbols for the support column.....	30
D.1.3	Instructions for completing the PCI ICS	30
D.2	Identification of the implementation	31
D.2.1	Date of statement.....	31
D.2.2	Implementation Under Test (IUT) identification	31
D.2.3	System Under Test (SUT) identification.....	31
D.2.4	Product supplier	31
D.2.5	Client	32
D.2.6	ICS contact person.....	32
D.3	PCI ICS/System Conformance Statement (SCS).....	33
D.4	Identification of the PCI.....	33
D.5	Global statement of conformance	33
D.6	Static requirements.....	33
D.6.1	Major capabilities.....	33
D.6.1.1	Underlying Operating System.....	33
D.6.1.2	Exchange Mechanism	34
D.6.1.3	Administration Plane classes.....	34
D.6.1.4	Control Plane classes	34
D.6.1.5	User Plane class.....	35
D.6.1.6	User Plane protocols	35
D.6.2	Messages.....	36
D.6.2.1	Administration Plane messages	36
D.6.2.2	Control Plane messages.....	37
D.6.2.3	User Plane messages	39
D.6.3	Miscellaneous features	40
Annex E (informative): Bibliography		41
History		42

Foreword

The fourth part of this final draft Interim European Telecommunication Standard (I-ETS) has been produced by the Terminal Equipment (TE) Technical Committee of the European Telecommunications Standards Institute (ETSI), and is now submitted for the Voting phase of the ETSI standards approval procedure.

An ETSI standard may be given I-ETS status either because it is regarded as a provisional solution ahead of a more advanced standard, or because it is immature and requires a "trial period". The life of an I-ETS is limited to three years after which it can be converted into an ETS, have its life extended for a further two years, be replaced by a new version, or be withdrawn.

This is the fourth part of a draft I-ETS which comprises four parts:

"Integrated Services Digital Network (ISDN); Conformance testing for the Euro-ISDN Programming Communication Interface (PCI):

part 1: "Test Suite Structure and Test Purposes (TSS&TP) for the PCI User Facility (PUF);

part 2: "Abstract Test Suite (ATS) for the PCI User Facility (PUF);

part 3: "Test Suite Structure and Test Purposes (TSS&TP) for the Network Access Facility (NAF);

part 4: "Abstract Test Suite (ATS) for the Network Access Facility (NAF)".

Proposed announcement date	
Date of latest announcement of this I-ETS (doa):	3 months after ETSI publication

Introduction

I-ETS 300 697, parts 1 to 4 comprises the Test Suite Structure and Test Purposes (TSS&TP) and the Abstract Test Suites (ATS) to ETS 300 325 [1]. The Euro-ISDN PCI is a PCI which provides access to the Euro-ISDN. The basic model of the ISDN PCI consists of two entities, a service user called the PCI User Facility (PUF) and a service provider called the Network Access Facility (NAF). For the purposes of conformance testing, the PUF and the NAF are treated separately. This is because the PUF manufacturer and the NAF manufacturer may be completely different and their testing needs should be treated separately. Each part is tested to ensure that they each meet the conformance requirements of the I-ETS and to increase their probability of inter-operating. This is the reason why a separate TSS&TP and a separate ATS has been produced for both the PCI User Facility (PUF) and the Network Access Facility (NAF).

All parts have been produced according to ISO/IEC 9646 [2] to [6] and ETS 300 406 [10].

As stated above, this I-ETS is structured in four parts:

- part 1 contains the TSS&TP for the PUF;
- part 2 contains the ATS for the PUF;
- part 3 contains the TSS&TP for the NAF;
- **part 4 contains the ATS for the NAF.**

Part 1 (TSS&TP for the PUF) contains all Test Purposes (TPs) for the PUF (PCI messages). It describes what is covered by the TPs for the PUF and what areas of the I-ETS are not covered. The Test Suite Structure (TSS) is described and the convention followed in naming the TPs is described. A list of basic interconnection tests is given.

Part 2 (ATS for the PUF) contains the ATS for the PUF (PCI messages). The test method used is described in detail and diagrams explaining the test method are presented. The reasons for choosing the test method are also given. The ATS is written in Tree and Tabular Combined Notation (TTCN) and the TTCN is contained in annex A. Annex B contains the Protocol Conformance Test Report (PCTR), annex C contains the Implementation eXtra Information for Testing (IXIT) and annex D contains an Implementation Conformance Statement (ICS).

Part 3 (TSS&TP for the NAF) contains all TPs for the NAF (PCI messages and Exchange Mechanism). It describes what is covered by the TPs for the NAF and what areas of the I-ETS are not covered. The TSS is described and the TPs are given. A list of basic interconnection tests is given.

Part 4 (ATS for the NAF) contains the ATS for the NAF (PCI messages and Exchange Mechanism). The test method used is described in detail and a diagram explaining the test method is given. The reasons for choosing that test method is also given. The ATS is written in concurrent TTCN and the TTCN is contained in annex A. Annex B contains the PCTR, annex C contains the IXIT and annex D contains an ICS.

NOTE: The ICS in annexes D of part 2 and part 4 are informative as ETS 300 325 [1] already contains an ICS. However, the ICS in ETS 300 325 [1] is not adequate for these ATSS and should, eventually, be replaced by annexes D of part 2 and part 4 of this I-ETS.

1 Scope

Part 4 of this draft I-ETS contains the Abstract Test Suite (ATS) for the Network Access Facility (NAF). The test method used is described in detail and diagrams explaining the test method are presented. The reasons for choosing this test method are also given. The ATS is written in Tree and Tabular Combined Notation (TTCN) and the TTCN is contained in annex A. Annex B contains the Protocol Conformance Test Report (PCTR), annex C contains the Implementation eXtra Information for Testing (IXIT) and annex D contains an Implementation Conformance Statement (ICS).

2 References

Part 4 of this draft I-ETS incorporates by dated or undated reference, provisions from other publications. These normative references are cited at the appropriate places in the text and the publications are listed hereafter. For dated references, subsequent amendments to or revisions of any of these publications apply to this part of this draft I-ETS only when incorporated in it by amendment or revision. For undated references the latest edition of the publication referred to applies.

- [1] ETS 300 325 (1994): "Integrated Services Digital Network (ISDN); Programming Communication Interface (PCI) for Euro-ISDN".
- [2] ISO/IEC 9646-1 (1991): "Information Technology - Open Systems Interconnection - Conformance testing methodology and framework - Part 1: General concepts".
- [3] ISO/IEC 9646-2 (1991): "Information Technology - Open Systems Interconnection - Conformance testing methodology and framework - Part 2: Abstract Test Suite specification".
- [4] ISO/IEC 9646-3 (1992): "Information Technology - Open Systems Interconnection - Conformance testing methodology and framework - Part 3: The Tree and Tabular Combined Notation (TTCN)".
- [5] ISO/IEC 9646-5 (1994): "Information Technology - Open Systems Interconnection - Conformance testing methodology and framework - Part 5: Requirements on test laboratories and clients for the conformance assessment process".
- [6] ISO/IEC DIS 9646-7 (1991): "Information Technology - Open Systems Interconnection - Conformance testing methodology and framework - Part 7: Implementation Conformance Statement".
- [7] Draft prETS 300 697-3: "Integrated Services Digital Network (ISDN); Conformance testing for the Euro-ISDN Programming Communication (PCI); Part 3: Test Suite Structure and Test Purposes (TSS&TP) for the Network Access Facility (NAF)".
- [8] ISO/IEC 8208 (1990): "Information technology; Data communications - X.25 Packet Layer Protocol for Data Terminal Equipment".
- [9] ETS 300 080: "Integrated Services Digital Network (ISDN); ISDN lower layer protocols for telematic terminals".
- [10] ETS 300 406 (1995): "Methods for Testing and Specification (MTS); Protocol and profile conformance testing specifications Standardization Methodology".
- [11] CCITT Recommendation T.70 (1998): "Network-independent basic transport service for the telematic services".

3 Definitions and abbreviations

3.1 Definitions

For the purposes of this I-ETS all definitions in ISO/IEC 9646, parts 1, 2, 3, 5 and 7 ([2] to [6]) and its amendments and draft amendments, and in ETS 300 325 [1] apply.

PCI Implementation Conformance Statement (PCI ICS) proforma: A document, in the form of a questionnaire, which when completed for a PCI implementation becomes the PCI ICS (see ISO/IEC DIS 9646-7 [6]).

PCI ICS: A statement made by the supplier of a PCI, stating which capabilities have been implemented for a given PCI (see ISO/IEC DIS 9646-7 [6]).

3.2 Abbreviations

For the purposes of this part of this I-ETS, the following abbreviations apply:

ASP	Abstract Service Primitive
ATS	Abstract Test Suite
CP	Co-ordination Point
ICS	Implementation Conformance Statement
IE	Information Element
ISDN	Integrated Services Digital Network
IUT	Implementation Under Test
IXIT	Implementation eXtra Information for Testing
MTC	Master Test Component
MTS	Methods for Testing and Specification
NAF	Network Access Facility
N/A	Not Applicable
OSI	Open Systems Interconnection
PCI	Programming Communication Interface
PCO	Point of Control and Observation
PCTR	Protocol Conformance Test Report
PDU	Protocol Data Unit
PTC	Parallel Test Component
PUF	Programming communication interface User Facility
SCS	System Conformance Statement
SUT	System Under Test
TC	Test Case
TCV	Test Case Variable
TP	Test Purpose
TSS	Test Suite Structure
TSS&TP	Test Suite Structure & Test Purposes
TSV	Test Suite Variable
TTCN	Tree and Tabular Combined Notation

4 Status

This ATS uses concurrent TTCN and has been edited using the ITEX tool, version 2.2. Since this tool contains bugs in the concurrent parts, parts of the test suite have not been parsed.

5 General constraints for testing and applicable test method

5.1 Testing Model

ETS 300 325 [1] is an interface standard and not a protocol standard. ISO/IEC 9646-1 [2] explicitly states that it applies only to protocols of the OSI stack. This means that ISO/IEC 9646, [2] to [6] could not be used directly for testing the NAF. Due to historical reasons, the solution for the NAF is not the same as for the PUF. In particular, the PCI messages and the Exchange Mechanism testing are not treated separately. The messages of the standard mapped onto Protocol Data Unit (PDUs) and the Exchange Mechanism functions are mapped onto Abstract Service Primitives (ASPs) for PCI messages testing AND for Exchange Mechanism testing.

5.2 Test method for PCI messages and Exchange Mechanism

Both the upper and the lower interfaces of the NAF with a tester placed at each interface can be controlled and observed:

- the lower interface of the NAF is the ISDN network interface (D-channel and B-channel). Although this interface is not really a part of the I-ETS (it is not the Euro-ISDN PCI), it was chosen to observe it to check that the NAF provides really the service. Moreover, the mapping between PCI messages and network PDUs are well defined in the ETS 300 325 [1].

There are 2 PCOs at this lower interface. PCO_D at which test events are Euro-ISDN protocol Layer 3 PDUs, and PCO_B at which test events are user protocol PDUs.

- the upper service boundary is its PCI interface with the PUF. There is one PCO (PCO_U) at this interface, at which the test events are ASPs (Exchange Mechanism functions).

A test co-ordination procedure shall be necessary to co-ordinate between the Upper and the Lower Testers. The nature of the interfaces and the use of a co-ordination procedure means that a distributed test method (see ISO/IEC 9646-2 [3]) is the most suitable test method for testing the NAF. Using this method, all of the test suite execution can be automated. Concurrent TTCN was required in order to develop the ATS because there are three Points of Control and Observation (PCOs) which need to be controlled simultaneously, i.e. the one at the upper boundary and two at the lower boundary for the D-channel and the B-channel.

5.3 Testing configuration

Figure 1 describes the testing configuration used throughout this ATS:

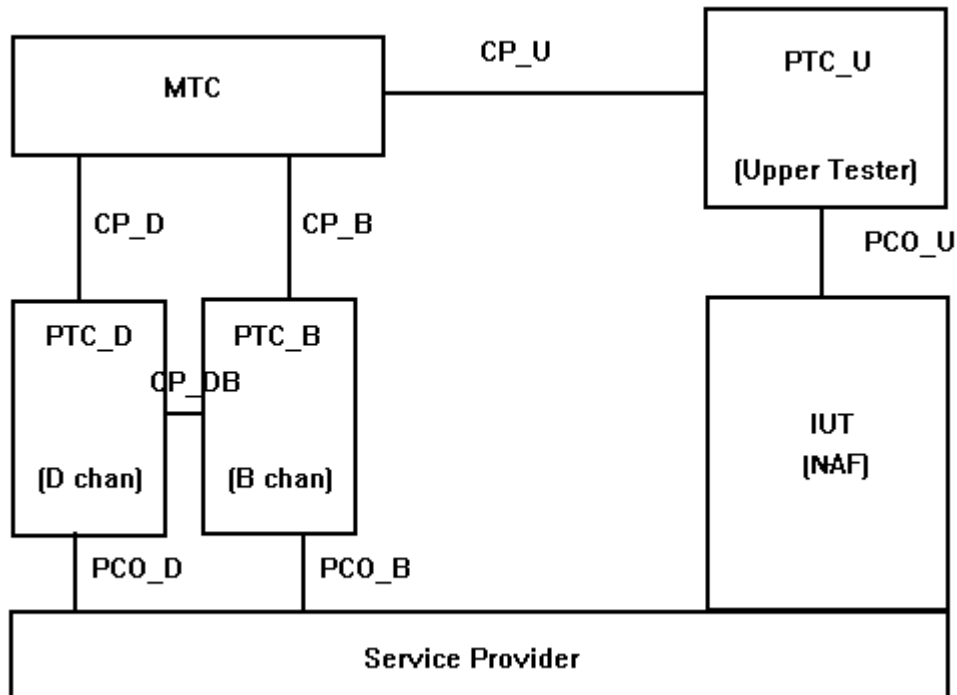

Figure 1: NAF test configuration using distributed test method

- Main Test Component (MTC);
- Parallel Test Component (PTC) (Upper, D-channel, B-channel);
- Implementation Under Test) (IUT) is the NAF under test;
- Co-ordination Point (CP) (between the PTCs and the PTCs and the MTC);
- Service Provider is the ISDN network access; it carries ISDN Layer 3 PDUs exchanged between the IUT and the D-channel part of the Lower Tester and ISDN B-channel PDUs exchanged between the IUT and the B-channel part of the Lower Tester;
- PCO-U is the PCO between the IUT, the Upper Tester (test events are ASPs: Exchange Mechanism functions and PDUs are PCI messages);
- PCO-D is the PCO between the IUT the D-channel emulator (test events are Euro-ISDN Layer 3 PDUs);
- PCO-B is the PCO between the IUT the B-channel emulator (test events are user connection Layer 3 PDUs).

The tester consists of a Main Test Component (MTC) which is responsible for:

- creating and terminating all Parallel Test Components (PTCs) within the test system;
- co-ordination between the PTCs involved in a test case;
- receipt of preliminary results from PTCs;
- computing the Test verdict.

and three PTCs:

- PTC-U, which corresponds to an Upper Tester playing the role of PCI User Facility (PUF) responsible for creating and destroying Network Connection Objects (NCOs);
- PTC_D, which corresponds to a Lower Tester playing the role of ISDN D-channel;
- PTC_B, which corresponds to a second Lower Tester playing the role of ISDN B-channel.

5.4 Mapping of PCI concepts into TTCN terms

Some terms within PCI have been mapped onto terms used within TTCN.

5.4.1 Exchange Mechanism functions

The functions used within the Exchange Mechanism correspond to the Abstract Service Primitives (ASPs) as defined in ISO/IEC 9646-3 [4].

Each function of the Exchange Mechanism used within ISDN PCI has been translated into an exchange of Abstract Service Primitives of the kind ASP_Req / ASP_Cnf. The reason why two ASPs are used for each Exchange Mechanism function is because in ETS 300 325 [1] the Exchange Mechanism functions are described as functions which are called with parameters and which return values. The returned values are passed in ASP_Cnf. e.g. the use of the Exchange Mechanism function PciRegister is done in this ATS the following way:

- PTC_U sending an ASP of the type *PciRegister_Req*;
- PTC_U receiving an ASP of the type *PciRegister_Cnf*.

The fact that these functions depend on the operating system, brought some problems to the definition of these ASPs. The following solution is used:

- each ASP_Req/ASP_Cnf type declaration contains all of the parameter fields corresponding to all the input/output parameters that are needed in UNIX, DOS and Windows operating systems;
- there is a different ASP constraint for each underlying operating system. Therefore:
 - three ASPs constraints of the type *PciRegister_Req* are defined, *PR_DOSReq*, *PR_UNIXReq* and *PR_WinReq*, one to be used with DOS, and one with UNIX and one with Windows;
 - three ASPs constraints of the type *PciRegister_Cnf* are defined, *PR_DOSConf*, *PR_UNIXCnf* and *PR_WinCnf*, one to be used with DOS, and one with UNIX and one with Windows.

All of these ASP constraints shall be parameterized according to the input/output values that vary for each of the operating systems in ETS 300 325 [1].

5.4.2 ISDN PCI messages

The PCI messages are translated into PDUs. The PDU parameters correspond to the PCI message parameters.

The way these PCI messages are sent and received from the NAF is never by a simple send or receive event at the associated PCO, in this case PCO_U. The PDUs shall always be carried inside the ASPs corresponding to the relevant exchange function, PciPutMessage or PciGetMessage. When a PDU is to be sent to the NAF, it shall be stored in one of the parameters of the PciPutMessage ASP. In order to reduce the complexity of the test case behaviour description by making the use of the exchange functions more transparent, test steps corresponding to the exchange functions shall be defined.

6 ATS naming conventions

The naming conventions described here have been chosen to ensure easy understanding of the ATS. As far as possible, the names reflect their role in the ATS. When a name is used to represent an item from ETS 300 325 [1], then the name shall be taken directly from ETS 300 325 [1] and usually prefixed with the relevant prefix. Where an identifier is made up of one or more words, the words shall each start with a capital letter.

- **Test suite variables** start with TSV_.

EXAMPLE 1: TSV_MaxNCOCcount.

- **Test suite parameters** start with TSP_.

EXAMPLE 2: TSP_LocalNumber.

- **Structured type definitions** are named to reflect the nature of the type.

EXAMPLE 3: GroupID is a structured type definition for the PCI parameter GroupID.

- Constraints on structured type definitions are used to represent the parameters of PCI messages.

EXAMPLE 4: NCOID is a structured type definition for the PCI parameter NCOID and par_NCOID is a constraint of type NCOID.

- **Simple type definitions** are named to reflect the nature of the type.

EXAMPLE 5: OCTETSTRING4 is a type definition for octetstrings of length 4.

- **Test case variables** start with TCV_.

EXAMPLE 6: TCV_SyncFlag.

- **Timers** start with a T.

EXAMPLE 7: T0, T1.

- **PCI messages** use the same names as in ETS 300 325 [1].

EXAMPLE 8: ACreateNCOReq.

- **PCI message parameters** use the same names as in ETS 300 325 [1] and are prefixed by par_. The fields of the parameters use the same names as the fields of the parameters in ETS 300 325 [1].

EXAMPLE 9: par_GroupID.

- There shall be a one-to-one mapping between the **test purpose identifiers** in ETS 300 697-3 [7] and the **test case names** used in this test suite. The TPxxxxxx maps to TCxxxxxx.

EXAMPLE 10: TP2213 maps to TC2213.

- **Test step** names reflect the purpose of the test step. Those which are concerned with preambles are prefixed with pre_ and those concerned with postambles are prefixed with post_.

EXAMPLE 11: pre_C2.

7 Notes on the ATS

7.1 Encoding of ISDN message Information Elements (IEs)

Only the Information Elements (IEs) which correspond to a PCI parameter, as for table B.2 of ETS 300 325 [1] shall have been coded mandatory in any of the ISDN messages that are used in the Test Suite.

The coding of these IEs was carried out taking into consideration the structure of the corresponding PCI parameter. This means that within an IE only those sub-fields which have a corresponding PCI parameter sub-field shall be coded.

7.2 Naming ISDN messages constraints

All the PDU constraints corresponding to ISDN messages have been suffixed according to the following rules:

- if the ISDN message is to be sent by the D-channel tester (constraint for SEND events), then it shall be suffixed with "_Sn", where n is a sequence number. It should be noted that these ISDN messages shall always be mapped to PCI messages coming from the NAF;
- if the ISDN message is to be received by the D-channel tester (constraint for RECEIVE events), then it shall be suffixed with "_Rn", where n is a sequence number. Again, these ISDN messages shall always be mapped from PCI messages previously sent by the Upper Tester.

7.3 Test Purposes grouping into a combined TP

Following ISO/IEC 9646-2 [3], subclauses 10.3.2 and 10.3.3, several individual TPs have been grouped into combined TPs. Where a test case is made up of combined TPs, the reference given is not to the I-ETS, but to the individual TPs in the TSS&TP (see ETS 300 697-3 [7]). These references are marked "(combined)" in the ATS.

7.4 Order of parameters

The parameters in either a PCI message or an ISDN message can be sent by the NAF in any order. This has not been taken into account in the test suite because all PDUs are represented in TTCN tabular form. This shall be dealt with by the implementor of the ATS.

8 Test Purpose to Test Case mapping

There is a one-to-one mapping between the test case identifiers and the TP identifiers used on the TSS&TP (see ETS 300 697-3 [7]) and they both have the same identifier except the TPs start with TP and the test cases start with TC.

EXAMPLE: TP1116 maps to TC1116.

Annex A (normative): Abstract Test Suite for the ETS 300 325 NAF

A.1 The TTCN Graphical form (TTCN.GR)

The TTCN.GR representation of this ATS is contained in a Postscript file (DEP6974.PS) which can be found on the diskette which accompanies this I-ETS.

A.2 The TTCN Machine Processable form (TTCN.MP)

The TTCN.MP representation corresponding to this ATS is contained in an ASCII file (DEP6974.MP) which can be found on the diskette which accompanies this I-ETS.

NOTE: According to ISO/IEC 9646-3 [4], in case of a conflict in interpretation of the operational semantics of TTCN.GR and TTCN.MP, the operational semantics of the TTCN.GR representation takes precedence.

Annex B (normative): PCTR for the ETS 300 325 NAF

This annex contains a PCTR proforma which shall be used by a test laboratory to document the results of conformance testing against ETS 300 325 [1] for the NAF, using the ATS specification in annex A, for a specific client.

Text in *italics* is comment for guidance only and shall not be included in the actual PCTR.

The name of the test laboratory, the PCTR number, the page number and the total number of pages should appear on every page of the PCTR.

The PCTR shall use the format given in the following pages:

B.1 Identification summary

B.1.1 Protocol Conformance Test Report

PCTR Number:

PCTR Date:

Test laboratory:

Accreditation status:

Accreditation reference:

Technical Authority:

Job Title:

Signature:

Test Laboratory Manager:

Signature:

B.1.2 IUT

Name:

Version:

Protocol specification(s):

Information object specification(s)

ICS:

B.1.3 Testing environment

IXIT:

ATS specification:

Abstract Test Method:

Means of testing identification:

Period of testing:

Conformance Log references(s):

Retention Date for Log reference(s):

B.1.4 Limits and reservations

Additional information relevant to the technical contents or further use of the test report, or the rights and obligations of the test laboratory and the client may be given here. Such information may include restrictions on the publication of the report.

The order of test cases listed in clause B.6 of this PCTR corresponds to the ordering of test cases defined in the ATS referenced in subclause B.1.3. This does not indicate that the test cases were executed in this order.

The test results presented apply only to the particular IUT declared in subclause B.1.2 of this PCTR, for functionality described in the relevant protocol Implementation Conformance Statement (ICS), as presented for test in the period declared in subclause B.1.3 and configured as declared in the relevant protocol Implementation eXtra Information for Testing (IXIT).

B.1.5 Comments

Additional comments may be given by either the client or the test laboratory on any of the contents of the PCTR, for example to note disagreement between the two parties.

B.2 IUT conformance status

This IUT has/has not been shown by conformance assessment to be non-conforming to the referenced base specification.

Strike the appropriate words in this sentence; if the ICS for this IUT is consistent with the static conformance requirements (as specified in clause B.3 of this PCTR) and there are no "FAIL" verdicts to be recorded in clause B.6 strike out the word "has/", otherwise strike out the words "/has not".

B.3 Static conformance summary

The ICS for this IUT is/is not consistent with the static conformance requirements in the specified protocol standard.

Strike out the appropriate words in this sentence.

B.4 Dynamic conformance summary

The test campaign did/did not reveal errors.

Strike out the appropriate words in this sentence; if there are no "FAIL" verdicts to be recorded in clause B.6 of this PCTR strike the work "did/" otherwise strike out the words "/did not".

In addition, a summary of the results of groups of test cases may be given. The detailed results of testing are provided in the table of clause B.6. This summary may, for example, give totals for the number of

passes, fails and inconclusives in each test group, and also allow the test laboratory to make observations on those results, such as "All the test cases concerned with segmented data transfer failed".

B.5 Static conformance review report

If clause B.3 indicates non-conformance, this clause itemises the mismatches between the ICS(s) and the static conformance requirements of the referenced base specification(s).

B.6 Test campaign report

This clause shall use the following table which indicates both the test case selection that was performed by the test laboratory, and the results of testing. The list of ATSS shall appear in this table in the same order as defined in the ATS specification. Notes on the information that the test laboratory shall be completed in the columns that are provided below.

Additional columns may be added for attaching other information which may be provided, e.g. mappings from ATS to ETS or conformance log reference for test cases that led to "Fail" or "Inconclusive verdicts".

Table B.1

ATS Reference (a)	Selected? Yes/No (b)	Run? Yes/No (c)	Verdict P/F/I (d)	Observations any (e)
Exchange Mechanism				
DOS				
TC1101a				
TC1101b				
TC1101				
TC1102				
TC1103				
TC1104				
TC1105				
TC1106				
TC1107				
TC1108				
TC1109				
TC1110				
TC1111				
TC1112				
TC1113				
TC1114				
TC1115				
TC1116				
TC1117				
TC1118				
UNIX				
TC1201a				
TC1201b				
TC1201				
TC1202				
TC1203				
TC1204				
TC1205				
TC1206				
TC1207				
TC1208				
TC1209				
Windows				
TC131				
TC132				
TC133				
TC134				
TC135				
TC136				
TC137				
TC138				
TC139				
TC1310				

Table B.1 (continued)

ATS Reference (a)	Selected? Yes/No (b)	Run? Yes/No (c)	Verdict P/F/I (d)	Observations any (e)
TC1311				
TC1313				
ADMIN				
MESSAGE				
CLASS 1				
TC2111				
TC2112				
TC2113				
TC2114				
TC2115				
TC2116				
TC2117				
TC2118				
TC21110				
TC21111				
TC21112				
TC21113				
CLASS 2				
TC2121				
TC2122				
CLASS 3				
TC2131				
TC2132				
TC2133				
SEL CRITERIA				
NCO SELECT				
TC2213				
TC2214				
TC2215				
TC2216				
TC2218				
TC2219				
RET CODE				
TC241				
TC243				
TC244				
TC245				
TC246				
TC247				
TC248				
TC249				
TC2410				
TC2411				
TC2412				
TC2413				
TC2414				

Table B.1 (continued)

ATS Reference (a)	Selected? Yes/No (b)	Run? Yes/No (c)	Verdict P/F/I (d)	Observations any (e)
TC2415				
TC2417				
TC2418				
TC2419				
TC2420				
TC2422				
CONTROL				
MSG MAP				
CLASS 1				
TC31101				
TC31102				
TC31103				
TC31104				
TC31105				
TC31106				
TC31107				
TC31108				
TC31110				
TC31112				
TC31114				
TC31115				
TC31116				
TC31117				
TC31118				
TC31120				
TC31122				
TC31124				
TC31126				
TC31128				
TC31130				
TC31132				
TC31134				
TC31136				
TC31137				
TC31138				
TC31140				
TC31142				
TC31144				
TC31146				
TC31148				
TC31150				
TC31152				
TC31154				
TC31155				
TC31156				
TC31157				

Table B.1 (continued)

ATS Reference (a)	Selected? Yes/No (b)	Run? Yes/No (c)	Verdict P/F/I (d)	Observations any (e)
CLASS 2				
TC31201				
TC31202				
TC31203				
CLASS 3				
TC31301				
TC31302				
TC31303				
TC31304				
CLASS 4				
TC31401				
TC31402				
TC31403				
TC31404				
TC31405				
TC31406				
TC31407				
CLASS 5				
TC31501				
TC31502				
TC31503				
TC31504				
TC31505				
CLASS 6				
TC31601				
TC31602				
TC31603				
TC31604				
TC31605				
TC31606				
TC31607				
TC31608				
ERR HANDLE				
INV STATE MSG				
TC32101				
TC32104				
TC32107				
TC32109				
TC32111				
MAND PARMISS				
TC32201				
TC32206				
TC32211				
MAND PARCONT				

Table B.1 (continued)

ATS Reference (a)	Selected? Yes/No (b)	Run? Yes/No (c)	Verdict P/F/I (d)	Observations any (e)
TC32306				
TC32307				
TC32308				
TC32311				
UNREC PAR				
TC32401				
TC32402				
TC32404				
TC32405				
TC32406				
TC32407				
OPT PARCONT				
TC32501				
TC32502				
TC32504				
USER				
PUFCOORD MSG				
TC412				
TC413				
TC414				
TC415				
TC416				
TC417				
TC419				
TC4110				
TC4111				
TC4112				
TC4113				
TC4115				
TC4116				
TC4120				
TC4123				
TC4138				
TC4142				
TC4151				
TC4154				
TC4158				
TC4165				
TC4166				
TC4168				
TC4169				
TC4173				

Table B.1 (continued)

ATS Reference <i>(a)</i>	Selected? Yes/No <i>(b)</i>	Run? Yes/No <i>(c)</i>	Verdict P/F/I <i>(d)</i>	Observations any <i>(e)</i>
TC4181				
TC4185				
TC4186				
TC4189				
TC4190				
TC4191				
TC4193				
TC4194				
TC4198				
TC4199				
TC41100				
TC41101				
TC41102				
TC41103				
TC41104				
TC41105				
NAFCOORDMSG				
TC421				
TC424				
TC425				
TC426				
TC427				
NMA MSG				
NMA ERRHAND				
TC43111				
TC43121				
TC43122				
TC43123				
TC43124				
TC43125				
TC43126				
TC43127				
TC43128				
TC43129				
CAUSES				
TC43131				
TC43132				
TC43133				
TC43134				
TC43135				
TC43136				

Table B.1 (concluded)

ATS Reference (a)	Selected? Yes/No (b)	Run? Yes/No (c)	Verdict P/F/I (d)	Observations any (e)
TC43147				
TC43138				
TC43139				
TC431310				
TC431311				
TC431312				
TC431313				
TC431314				
TC431315				
TMA MSG				
TC441				
TC442				
TC443				
ERR HANDLE				
TC4412				
TC4413				
TC4414				
TC4415				

- a) Reference to the abstract test case from the ATS specification. This is the same as the TP identifier in the TSS&TP.
- b) Indicate whether the test case was selected for execution against the IUT identified in subclause B.1.2 according to the analysis of the information in the ICS and IXIT for the IUT. If the test case is deselected on the basis of the IXIT then the test laboratory shall indicate why, by use of the observation column, by reference to the relevant IXIT clause. The test laboratory may also provide clarification regarding which ICS entries led to deselection, whether the deselection is as a result of evaluating the selection expression or directly as a result of ICS entries.
- c) If the test was selected, indicate whether or not the test was run to completion. If the status of the test was "not run", indicate why by use of the observation column.
- d) Enter the verdict as assigned during the test campaign for each test case run.
- e) Enter an observation or a reference to any relevant observations made in clause B.7 of this PCTR.

B.7 Observations

Additional information relevant to the technical content of the PCTR may be given here.

Annex C (normative): Partial IXIT proforma for the ETS 300 325 NAF

C.1 Identification summary

IXIT Number:

Test Laboratory Name:

Date of Issue:

Issued to:

C.2 Abstract Test Suite summary

Protocol specification:

ATS specification:

Abstract test method:

C.3 Test laboratory

Test Laboratory Identification:

Accreditation status of the test service:

Accreditation reference:

Test Laboratory Manager:

Test Laboratory Contact:

Means of Testing:

Instructions for Completion:

C.4 Client

Client Identification:

Client Test Manager:

Client contact:

Test Facilities Required:

C.5 SUT

Name:

Version:

SCS Reference:

Machine Configuration:

Operating System Identification:

IUT Identification:

ICS:

Limitations of the SUT:

Environmental Conditions:

C.6 Protocol information for the ETS 300 325 NAF

C.6.1 Protocol identification

Specification reference:

Protocol version:

ICS reference:

C.6.2 IUT information

This IXIT contains extra information necessary for the testing of the NAF implementation. In some tables specific information is requested while in others the client is requested to select an option.

Table C.1: NAF Information

Item N°	NAF Information
1	In the case of a DOS implementation, give the pathname of the PCIDD device driver used:
2	State the PCIHandle corresponding to the IUT:
3	State the maximum number of PCI-handles that can be received:
4	State the value of the MessageMaximumSize supported by Exchange Mechanism of the NAF:
5	State the value of the DataMaximumSize supported by Exchange Mechanism of the NAF:

Table C.2: Local and remote numbers

Item N°	Local and remote numbers
1	State the local number:
2	State the local subaddress:
3	State the remote number:
4	State the remote subaddress:

Table C.3: Property size

Item N°	Property size	Information
1	State the maximum size of a NAFproperty necessary to get the list of properties of the NAF.	
2	State a value which is less than that required to get the list of all properties.	

Table C.4: Manufacturer codes

Item N°	Manufacturer codes	Information
1	Give an example of a Manufacturer Code supported by the NAF.	
2	Give an example of a Manufacturer Code not supported by the NAF.	

Table C.5: External equipment

Item N°	External equipment name	Information
1	Give the name of the External equipment type 1.	
2	Give the name of the External equipment type 2.	

Table C.6: Layer 2, Layer 3 protocols

Item Nº	Layer 2, Layer 3 protocols	opt
1	In the case of the Bearer Capability IE User Information octet Layer 2 protocol, choose option 1 or 2: 1) ITU-T Recommendation Q.921. 2) ITU-T Recommendation X.25 link level.	
2	In the case of the Bearer Capability IE User Information octet Layer 3 protocol, choose option 1 or 2: 1) ITU-T Recommendation Q.931. 2) ITU-T Recommendation X.25 packet layer.	

Annex D (informative): ETS 300 325 NAF PCI ICS Proforma

ETS 300 325 [1], annex G (normative) contains a PCI ICS for the whole of the ETS. That ICS is not sufficient for the ATS in annex A of this part of the I-ETS, therefore this informative annex contains the ICS applicable to annex A. This annex should eventually supersede annex G of ETS 300 325 [1].

This annex contains a PCI ICS Proforma for the NAF element of ETS 300 325 [1]. The NAF PCI ICS Proforma lists all mandatory, conditional and optional items of the ISDN PCI specification relating to the Exchange Mechanism and the messages. It should be used in the process of evaluating a particular NAF implementation when claiming conformance to ISDN PCI specification. The PCI ICS Proforma is a record of which items are supported by the tested NAF.

Conformance requirement concerning the PCI ICS

A conforming ICS proforma should be technically equivalent to annex D and preserve the numbering and ordering of the items in annex A.

An ICS which conforms to this I-ETS:

- a) describes an implementation which conforms to ETS 300 325 [1];
- b) is a conforming ICS proforma, which has been completed in accordance with the instructions given in clause D.1;
- c) includes the information necessary to uniquely identify both the supplier and the implementation.

Notwithstanding the provisions of the copyright clause related to the text of this I-ETS, ETSI grants that users of this I-ETS may freely reproduce the ICS proforma in this clause so that it can be used for its intended purposes and may further publish the completed ICS.

D.1 Instructions for completing the NAF PCI ICS proforma

D.1.1 Purposes and structure

The purpose of this PCI ICS is to provide a mechanism whereby a supplier of an implementation of the requirements of ETS 300 325 [1] may provide information in a standard form.

The PCI ICS proforma is subdivided into sections for the following categories of information:

- implementation identification
- PCI identification
- global statement conformance
- static requirements
 - Major capabilities
 - Operating systems
 - Exchange Mechanism
 - Connection type
 - Administration Plane classes
 - Control Plane classes
 - User Plane protocols
 - User Plane classes
 - Messages
 - Administration Plane messages
 - Control Plane messages
 - User Plane messages
 - Miscellaneous

A NAF should support all parameters of a supported message, because it should be able to supply parameters coming from the network (NAF -> PUF direction) see ETS 300 325 [1], subclause 6.1.2, and should be able to support any parameter received from the PUF. Thus parameters are not detailed in specific ICS proforma tables.

D.1.2 Conventions

The PCI ICS proforma contained in this annex comprises information in a tabular form in accordance with the guidelines presented in ISO/IEC DIS 9646-7 [6].

References within tables are to ETS 300 325 [1], except where otherwise stated.

D.1.2.1 Standardized symbols for the status column

The following notations, defined in ISO/IEC DIS 9646-7 [6], are used in the proforma to indicate the status of a question:

- M (mandatory): the capability is required to be implemented, in conformance with the PCI standard;
- O (optional): the capability may be implemented, and if it is implemented it is required to conform to the PCI specification (cf ISO/IEC 9646-1 [2], clause A.3);
- O.n (optional): the capability may be implemented, and if it is implemented it is required to conform to the PCI specification, and the option is mutually exclusive or selectable among a set (cf ISO/IEC 9646-1 [2], clause A.3);
- X (prohibited): there is a requirement not to use this capability in a given context;
- C (conditional): the requirement on the capability depends on the selection of other optional or conditional items;
- N/A (not applicable): in the given context the base specification makes it impossible to use this capability.

If appropriate, a "C" followed by an integer is placed in the status column, providing a reference to a conditional status expression (i.e. predicate expression) defined as a note inside the table. As defined in ISO/IEC DIS 9646-7 [6], this predicate expression is consistent with TTCN boolean expressions (i.e. IF ... THEN (IF ... THEN ELSE) ELSE). In all cases, "ELSE N/A" is implied if an ELSE clause is omitted.

D.1.2.2 Standardized symbols for the support column

To specify the level of support for all entries, the standardized symbols for the support column are as follows:

Y	supported - the capability is implemented in conformance with the I-ETS.
N	not supported - the capability is not implemented.
N/A or no answer required	no answer required - the question has a status value of either not-applicable or out-of-scope.

D.1.3 Instructions for completing the PCI ICS

The supplier of the implementation enters an explicit statement in each of the support columns provided using the notation described in subclause A.1.2.

D.2 Identification of the implementation

D.2.1 Date of statement

.....

D.2.2 Implementation Under Test (IUT) identification

IUT name:

.....
.....

IUT version:

.....

D.2.3 System Under Test (SUT) identification

SUT name:

.....
.....

Hardware configuration:

.....
.....
.....

Operating system:

.....

D.2.4 Product supplier

Name:

.....

Address:

.....
.....
.....

Telephone number:

.....

Facsimile number:

.....

Additional information:

.....
.....
.....

D.2.5 Client

Name:

.....

Address:

.....
.....
.....

Telephone number:

.....

Facsimile number:

.....

Additional information:

.....
.....
.....

D.2.6 ICS contact person

Name:

.....

Telephone number:

.....

Facsimile number:

.....

Additional information:

.....
.....
.....

D.3 PCI ICS/System Conformance Statement (SCS)

Provide the relationship of the PCI ICS with the SCS for the system:

.....

.....

.....

.....

D.4 Identification of the PCI

This PCI ICS proforma applies to the following standard: ETS 300 325 [1] for the NAF.

D.5 Global statement of conformance

The supplier of the implementation states whether or not all mandatory capabilities are implemented for ETS 300 325 [1].

Table D.1: Global statement of conformance

Are all mandatory capabilities implemented?	
Are all parameters of supported messages supported? ref. subclause 6.1.2.	
NOTE: Answering "No" to one of these questions indicates non-conformance to the PCI specification. Non-supported mandatory capabilities are to be identified in the PCI ICS, with an explanation of why the implementation is non-conforming.	

D.6 Static requirements

D.6.1 Major capabilities

D.6.1.1 Underlying Operating System

Table D.2: Underlying Operating System

Item N°	Item of ISDN PCI	Ref./note	Status	Support
1	DOS	Annex F, clause F.1	O.1	
2	UNIX	Annex F, clause F.3	O.1	
3	Windows	Annex F, clause F.2	O.1	
O.1: It is mandatory to support at least one of these options.				
NOTE: The clauses referred to in column 3 are as given in ETS 300 325 [1].				

D.6.1.2 Exchange Mechanism**Table D.3: Exchange Mechanism**

Item N°	Item of ISDN PCI	Ref./note	Status	Support
1	Declaration	F.4	M	
2	Extraction	F.4	M	
3	PciGetProperty	7.1.3	M	
4	PciRegister	7.1.4	M	
5	PciPutMessage	7.3.6	M	
6	PciGetMessage	7.3.7	M	
7	PciSetSignal	7.3.8	M	
8	PciDeRegister	7.2.1	M	

NOTE: The clauses/subclauses referred to in column 3 are as given in ETS 300 325 [1].

D.6.1.3 Administration Plane classes**Table D.4: Administration Plane classes**

Item N°	Item of ISDN PCI	Ref./note	Status	Support
1	Administration Plane message class 1 Basic class	6.2	M	
2	Administration Plane message class 2 Security features	6.2	O	
3	Administration Plane message class 3 Manufacturer specific features	6.2	O	

NOTE: The subclasses referred to in column 3 are as given in ETS 300 325 [1].

D.6.1.4 Control Plane classes**Table D.5: Control Plane classes**

Item N°	Item of ISDN PCI	Ref./note	Status	Support
1	Control Plane message class 1 Basic class	6.3	M	
2	Control Plane message class 2 Overlap sending	6.3	O	
3	Control Plane message class 3 User-to-user information transfer	6.3	O	
4	Control Plane message class 4 Call adjournment for telephony	6.3	O	
5	Control Plane message class 5 Facility invocation	6.3	O	
6	Control Plane message class 6 External Equipment handling	6.3	O	

NOTE: The subclasses referred to in column 3 are as given in ETS 300 325 [1].

D.6.1.5 User Plane class**Table D.6: User Plane class**

Item N°	Item of ISDN PCI	Ref./note	Status	Support
1	User Plane message class 1 Basic class	6.4	M	
NOTE: The subclauses referred to in column 3 are as given in ETS 300 325 [1].				

D.6.1.6 User Plane protocols**Table D.7: User Plane Protocols**

Item N°	Item of ISDN PCI	Ref./note	Status	Support
1	Network layer protocol according to ETS 300 080 [9]	5.4.4.2	M	
2	Network layer protocol according to ISO/IEC 8208 [8]	5.4.4.2	M	
3	Transparent User Plane protocol	5.4.4.1	M	
4	Network layer protocol according to network layer of CCITT Recommendation T.70 [11]	5.4.4.2	O	
5	Network layer protocol using Null Layer 3 with access to X.75 on Layer 2	5.4.4.2	O	
6	Network layer protocol using Null Layer 3 with transparent access to HDLC framing	5.4.4.2	O	
NOTE: The subclauses referred to in column 3 are as given in ETS 300 325 [1].				

D.6.2 Messages

D.6.2.1 Administration Plane messages

Table D.8: Administration Plane messages

Item N°	Item of ISDN PCI	Ref./note	Status	Support
1	ACreateNCOReq	6.2.1	M	
2	ACreateNCOConf	6.2.3	M	
3	ADestroyNCOReq	6.2.4	M	
4	ADestroyNCOConf	6.2.5	M	
5	AGetNCOInfoReq	6.2.7	M	
6	AGetNCOInfoConf	6.2.8	M	
7	AErrorInd	6.2.6	M	
8	ASecurityReq	6.2.9	C1	
9	ASecurityConf	6.2.10	C1	
10	AManufacturerReq	6.2.11	C2	
11	AManufacturerInd	6.2.12	C2	
C1:	IF A.4/2 THEN M ELSE X			
C2:	IF A.4/3 THEN M ELSE X			
NOTE:	The subclauses referred to in column 3 are given in ETS 300 325 [1].			

D.6.2.2 Control Plane messages

Table D.9: Control Plane messages

Item N°	Item of ISDN PCI	Ref./note	Status	Support
1	CAAlertReq	6.3.2	M	
2	CAAlertInd	6.3.3	M	
3	CConnectReq	6.3.4	M	
4	CConnectInd	6.3.5	M	
5	CConnectRsp	6.3.6	M	
6	CConnectCnf	6.3.7	M	
7	CDisconnectReq	6.3.8	M	
8	CDisconnectInd	6.3.9	M	
9	CDisconnectRsp	6.3.10	M	
10	CDisconnectCnf	6.3.11	M	
11	CProgressInd	6.3.12	M	
12	CStatusInd	6.3.13	M	
13	CSetupAckInd	6.3.14	C3	
14	CConnectInfoReq	6.3.15	C3	
15	CProceedingInd	6.3.16	C3	
16	CUserInformationReq	6.3.17	C4	
17	CUserInformationInd	6.3.18	C4	
18	CCongestionControlReq	6.3.19	C4	
19	CCongestionControlInd	6.3.20	C4	
20	CSuspendReq	6.3.21	C5	

Table D.9 (concluded): Control Plane messages

Item N°	Item of ISDN PCI	Ref./note	Status	Support
21	CSuspendCnf	6.3.22	C5	
22	CResumeReq	6.3.23	C5	
23	CResumeCnf	6.3.24	C5	
24	CNotifyInd	6.3.25	C5	
25	CFacilityReq	6.3.26	C6	
26	CFacilityInd	6.3.27	C6	
27	CExtEquipAvailabilityInd	6.3.28	C7	
28	CExtEquipBlockDiallingInd	6.3.29	C7	
29	CExtEquipKeyPressedInd	6.3.30	C7	
30	CExtEquipOffHookInd	6.3.31	C7	
31	CExtEquipOnHookInd	6.3.32	C7	
C3:	IF A.5/2 THEN M ELSE X			
C4:	IF A.5/3 THEN M ELSE X			
C5:	IF A.5/4 THEN M ELSE X			
C6:	IF A.5/5 THEN M ELSE X			
C7:	IF A.5/6 THEN M ELSE X			
NOTE:	The subclauses referred to in column 3 are as given in ETS 300 325 [1].			

D.6.2.3 User Plane messages

Table D.10: User Plane messages

Item N°	Item of ISDN PCI	Ref./note	Status	Support
1	U3ConnectReq	6.4.3	M	
2	U3ConnectInd	6.4.4	M	
3	U3ConnectRsp	6.4.5	M	
4	U3ConnectCnf	6.4.6	M	
5	U3DisconnectReq	6.4.7	M	
6	U3DisconnectInd	6.4.8	M	
7	U3DataReq	6.4.9	M	
8	U3DataInd	6.4.10	M	
9	U3ExpeditedDataReq	6.4.11	M	
10	U3ExpeditedDataInd	6.4.12	M	
11	U3ResetReq	6.4.13	M	
12	U3ResetInd	6.4.14	M	
13	U3ResetRsp	6.4.15	M	
14	U3ResetCnf	6.4.16	M	
15	U3DataAcknowledgeReq	6.4.17	M	
16	U3DataAcknowledgeInd	6.4.18	M	
17	U3ReadyToReceiveReq	6.4.19	M	
18	U3ReadyToReceiveInd	6.4.20	M	
19	U3ErrorInd	6.4.21	M	
20	U1DataReq	6.4.22	M	
21	U1DataInd	6.4.23	M	
22	U1ErrorInd	6.4.24	M	
NOTE: The subclauses referred to in column 3 are as given in ETS 300 325 [1].				

D.6.3 Miscellaneous features

Table D.11: Miscellaneous features

Item N°	Item of ISDN PCI	Ref./note	Status	Support
1	Transparent coding of facility information element	6.6.31	O	
2	NAF co-ordination	5.2.4	M	
3	Does the NAF allow access to more than one NCO concurrently	4.3.7	O	
NOTE: The subclauses referred to in column 3 are as given in ETS 300 325 [1].				

Annex E (informative): Bibliography

For the purposes of this I-ETS, the following recommendations have been used for information:

- 1) ITU-T Recommendation Q.921 (1993): "ISDN user-network interface - Data link layer specification".
- 2) ITU-T Recommendation Q.931 (1993): "Digital subscriber Signalling System No. 1 (DSS 1) - ISDN user-network interface layer 3 specification for basic call control".
- 3) ITU-T Recommendation X.25 (1993): "Interface between data terminal equipment (DTE) and data circuit-terminating equipment (DCE) for terminals operating in the packet mode and connected to public data networks by dedicated circuit".

History

Document history			
July 1995	Public Enquiry	PE 87:	1995-07-10 to 1995-11-03
December 1997	Vote	V 9809:	1997-12-30 to 1998-02-27