



EUROPEAN
TELECOMMUNICATION
STANDARD

FINAL DRAFT
pr **ETS 300 675**

August 1996

Source: ETSI TC-TE

Reference: DE/TE-04031

ICS: 33.080

Key words: audiographic, conference, inband, ISDN, stage 1

**Integrated Services Digital Network (ISDN);
Audiographic conference teleservice;
Service description**

ETSI

European Telecommunications Standards Institute

ETSI Secretariat

Postal address: F-06921 Sophia Antipolis CEDEX - FRANCE

Office address: 650 Route des Lucioles - Sophia Antipolis - Valbonne - FRANCE

X.400: c=fr, a=atlas, p=etsi, s=secretariat - **Internet:** secretariat@etsi.fr

Tel.: +33 92 94 42 00 - Fax: +33 93 65 47 16

Copyright Notification: No part may be reproduced except as authorized by written permission. The copyright and the foregoing restriction extend to reproduction in all media.

© European Telecommunications Standards Institute 1996. All rights reserved.

Contents

Foreword	5
1 Scope	7
2 Normative references	7
3 Definitions	9
4 Abbreviations	10
5 Description	10
5.1 General description	10
5.2 Basic facilities	10
5.2.1 Audio facilities	10
5.2.2 Conference control facility	11
5.2.3 Data transmission facility	11
5.2.4 Graphics facility	11
5.3 Other facilities	11
6 Procedures	11
6.1 Provision and withdrawal	11
6.2 Normal procedures	12
6.2.1 Originating the call (call establishment)	12
6.2.2 Indications during call establishment	13
6.2.3 Terminating the conference	13
6.2.3.1 Point-to-point conference	13
6.2.3.2 Multipoint conference	13
6.2.4 Change of communication mode	13
6.2.5 Multipoint control	14
6.2.6 Data communication	14
6.3 Exceptional procedures	14
6.3.1 Situations at the calling user side	14
6.3.2 Situations at the called user side	14
6.3.3 Situations due to network conditions	15
6.3.4 Retention of call information	15
7 Intercommunication and interworking considerations	15
7.1 Fall-back procedures	15
7.1.1 Fall-back to the telephony 3,1 kHz teleservice	15
7.1.1.1 Procedures	15
7.1.1.2 Interworking with non-ISDNs	16
7.1.2 Fall-back to the telephony 7 kHz teleservice	16
7.2 Interworking with private ISDNs	16
7.3 Restricted network operation	16
8 Interaction with other supplementary services	16
9 Static description of the service using attributes	17
9.1 Low layer attributes	17
9.2 Access attributes	17
9.3 High layer attributes	18
9.4 General attributes	18
Annex A (informative): Relation between standards and recommendations relevant for the audiographic conference service	19

Annex B (informative):	Applicability of supplementary services to the audiographic conference teleservice	20
B.1	General	20
B.2	Audiographic conference based on one circuit-mode 64 kbit/s connection	20
B.3	Audiographic conference based on two or more circuit-mode 64 kbit/s connections.....	21
Annex C (informative):	Bibliography	22
History		23

Foreword

This final draft European Telecommunication Standard (ETS) has been produced by the Terminal Equipment (TE) Technical Committee of the European Telecommunications Standards Institute (ETSI), and is now submitted for the Voting phase of the ETSI standards approval procedure.

Proposed transposition dates	
Date of latest announcement of this ETS (doa):	3 months after ETSI publication
Date of latest publication of new National Standard or endorsement of this ETS (dop/e):	6 months after doa
Date of withdrawal of any conflicting National Standard (dow):	6 months after doa

Blank page

1 Scope

This European Telecommunication Standard (ETS) defines the stage one of the audiographic conference teleservice for the pan-European Integrated Services Digital Network (ISDN) as provided by European public telecommunications operators. Stage one is an overall service description from the user's point of view (see CCITT Recommendation I.130 in annex C), but does not deal with the details of the human interface itself.

This ETS defines the interworking requirements of private ISDNs with the public ISDN.

In addition, this ETS specifies the base functionality where the service is provided to the user via a private ISDN.

This ETS does not specify the additional requirements where the service is provided to the user via a telecommunications network that is not an ISDN but does include interworking requirements of other networks with the public ISDN.

Charging principles are outside the scope of this ETS.

The values of the general attributes are outside the scope of this ETS.

The audiographic conference teleservice is a real-time teleservice in which high quality speech, control signals and data are interchanged using one or more circuit-mode 64 kbit/s connection(s).

This ETS is applicable to the stage two and stage three standards for the ISDN audiographic conference teleservice. The terms "stage two" and "stage three" are also defined in CCITT Recommendation I.130. Where the text indicates the status of a requirement (i.e. as strict command or prohibition, as authorisation leaving freedom, or as a capability or possibility), this will be reflected in the text of the relevant stage two and stage three standards.

Furthermore, conformance to this ETS is met by conforming to the stage three standard with the field of application appropriate to the equipment being implemented concerning characteristics at the user-network interface, and by conforming to the ETS on the end-to-end characteristics appropriate to the equipment being implemented. Therefore, no method of testing is provided for this ETS.

NOTE: In the current version of this ETS the use of protocols in the ITU-T T.120 series of recommendations (see annex C) is an option. This position may be reviewed later.

2 Normative references

This ETS incorporates by dated or undated reference, provisions from other publications. These normative references are cited at the appropriate places in the text and the publications are listed hereafter. For dated references, subsequent amendments to, or revisions of any of these publications apply to this ETS only when incorporated in it by amendment or revision. For undated references the latest edition of the publication referred to applies.

- [1] CCITT Recommendation I.112 (1985)88: "Vocabulary of terms for ISDNs".
- [2] CCITT Recommendation I.221 (1985)88: "Common specific characteristics of services".
- [3] ETS 300 144 (1996): "Integrated Services Digital Network (ISDN); Audiovisual services; Frame structure for a 64 kbit/s to 1 920 kbit/s channel and associated syntax for inband signalling".
- [4] ETS 300 111 (1992): "Integrated Services Digital Network (ISDN); Telephony 3,1 kHz teleservice, Service description".
- [5] ETS 300 263 (1994): "Integrated Services Digital Network (ISDN); Telephony 7 kHz teleservice, Service description".

- [6] CCITT Recommendation G.728 (1992): "Coding of speech at 16 kbit/s using low-delay code-excited linear prediction".
- [7] ETS 300 143 (1994): "Integrated Services Digital Network (ISDN): Audiovisual services; Inband signalling procedures for audiovisual terminals using digital channels up to 2 048 kbit/s".
- [8] ITU-T Recommendation T.122 (1985)93: "Multipoint communication service for audiographics and audiovisual conferencing service definition".
- [9] ITU-T Recommendation T.124 (1995): "Generic conference control".
- [10] ITU-T Recommendation T.123 (1985)94: "Protocol stacks for audiographic and audiovisual teleconference applications".
- [11] CCITT Recommendation G.711 (1985)88: "Pulse code modulation (PCM) of voice frequencies".
- [12] CCITT Recommendation G.722 (1985)88: "7 kHz audio-coding within 64 kbit/s".
- [13] ETS 300 483 (1996): "Terminal Equipment (TE); Integrated Services Digital Network (ISDN); Multipoint communication for audiovisual services; Main functionalities and basic requirements for Multipoint Control Units (MCUs)".
- [14] ETS 300 345 (1995): "Integrated Services Digital Network (ISDN): Interworking between public ISDNs and private ISDNs for the provision of telecommunication services. General aspects."
- [15] ITU-T Recommendation H.242 (1985)96: "System for establishing communication between audiovisual terminals using digital channels up to 1 920 kbit/s".
- [16] CCITT Recommendation I.140 (1985)88: "Attribute technique for the characterisation of telecommunication services supported by an ISDN and network capabilities of an ISDN".
- [17] ETS 300 011 (1992): "Integrated Services Digital Network (ISDN); Primary rate user-network interface, Layer 1 specification and test principles".
- [18] ETS 300 012 (1992): "Integrated Services Digital Network (ISDN); Basic user-network interface, Layer 1 specification and test principles".
- [19] ETS 300 403-1 (1995): "Integrated Services Digital Network (ISDN); Digital Subscriber Signalling System No. one (DSS1) protocol; Signalling network layer for circuit-mode basic call control; Part 1: Protocol specification (ITU-T Recommendation Q.931 (1993), modified)".
- [20] ETS 300 402-1 (1995): "Integrated Services Digital Network (ISDN); Digital Subscriber Signalling System No. one (DSS1) protocol; Data link layer; Part 1: General aspects (ITU-T Recommendation Q.920 (1993), modified)".
- [21] ETS 300 267-1 (1994): "Integrated Services Digital Network (ISDN); Telephony 7 kHz and videotelephony teleservices Digital Subscriber Signalling System No. one (DSS1) protocol; Part 1: Protocol specification".
- [22] ITU-T Recommendation H.243 (1985)93: "Procedures for establishing communication between three or more audiovisual terminals using digital channels up to 1920 kbit/s".
- [23] ITU-T Recommendation T.125 (1994): "Multipoint communication service protocol specification".

3 Definitions

For the purposes of this ETS, the following definitions apply:

Integrated Services Digital Network (ISDN): An integrated services network that provides digital connections between user-network interfaces (CCITT Recommendation I.112 [1], subclause 2.3, definition 308).

restricted network: A network consisting of multiples of 64 kbit/s links, but where only multiples of 56 kbit/s are usable for the terminals.

service; telecommunications service: That which is offered by a service provider to its customers in order to satisfy a specific telecommunication requirement (CCITT Recommendation I.112 [1], subclause 2.2, definition 201).

NOTE: Bearer service and teleservice are types of telecommunication service. Other types of telecommunication service may be identified in the future.

supplementary service: A service which modifies or supplements a basic telecommunication service. Consequently, it cannot be offered to a customer as a standalone service. It needs to be offered together with or in association with a basic telecommunication service. The same supplementary service may be common to a number of telecommunication services (based on CCITT Recommendation I.210, subclause 2.4).

teleservice: A type of telecommunication service that provides the complete capability, including terminal equipment functions, for communication between users according to protocols established by agreement between service providers (CCITT Recommendation I.112 [1], subclause 2.2, definition 203).

audiographic conference terminal: A terminal that supports the audiographic conference teleservice.

7 kHz terminal: A terminal that supports the telephony 7 kHz teleservice.

3,1 kHz terminal: A terminal that supports only the telephony 3,1 kHz teleservice.

videotelephone terminal: A terminal that supports the videotelephony teleservice.

fall-back: The mechanism whereby the request for the audiographic conference service, which includes an indication that an alternative teleservice is acceptable, results in a call using the alternative teleservice. In the case of the audiographic conference teleservice, the alternative teleservices are the telephony 7 kHz or the telephony 3,1 kHz teleservices.

served user: A user to whom the audiographic conference teleservice is provided.

network determined user busy: As described in CCITT Recommendation I.221 [2], subclause 2.1.4.

user determined user busy: As described in CCITT Recommendation I.221 [2], subclause 2.1.4.

retention timer: This timer specifies the amount of time that the network retains all the call information supplied by the calling user when the call encounters busy or is terminated. Implementation of this timer is a network option. The value for this timer shall be greater than 15 seconds.

Multipoint Control Unit (MCU): A piece of equipment located in a node of the network or in a terminal that connects several terminals and, according to certain criteria, processes audiovisual signals and distributes them to the connected terminals.

sub-channel: Each bit position of the byte of a 64 kbit/s channel as defined in ETS 300 144 [3].

service channel: The eight sub-channels of a 64 kbit/s channel as defined in ETS 300 144 [3].

Multi Layer Protocols (MLP): As defined in the ITU-T T.120 series of recommendations.

ISDN number: A number conforming to the numbering plan and structure specified in CCITT Recommendation E 164.

4 Abbreviations

For the purposes of this ETS, the following abbreviations apply:

ISDN	Integrated Services Digital Network
MCS	Multipoint Communication Service
MCU	Multipoint Control Unit
MLP	Multi Layer Protocols
PSTN	Public Switched Telephone Network

5 Description

5.1 General description

The audiographic conference teleservice is a real-time teleservice in which speech is transmitted together with signals for conference control and data communication between a terminal and a Multipoint Control Unit (MCU) or between two terminals by means of one or more 64 kbit/s circuit-mode connections in the ISDN.

The audiographic conference teleservice comprises two cases:

- case a): audiographic conference based on using one circuit-mode 64 kbit/s connection; and
- case b): audiographic conference based on using two or more circuit-mode 64 kbit/s connections.

An audiographic conference terminal shall be capable of supporting the telephony 3,1 kHz teleservice as described in ETS 300 111 [4] and the telephony 7 kHz teleservice as described in ETS 300 263 [5]. To improve the data communication capacity, the encoding specified in CCITT Recommendation G.728 [6] may be implemented as an option.

The audiographic conference teleservice shall allow communication between:

- two users (e.g. terminals) in a point-to-point configuration via the ISDN over a B-channel;
- three or more users in a multipoint configuration.

User information and user-to-user signalling shall be transferred over the B-channel. User-network signalling shall be provided over the D-channel.

A Multipoint Control Unit (MCU), to which all locations are connected individually over the ISDN, is required for the interconnection of three or more users in a multipoint configuration. Two or more MCUs may be interconnected to increase the number of participants of a multipoint conference.

The network provides tones and/or announcements to support this teleservice. Tones and/or announcements can be used to indicate the progress (or lack of progress) of a call. The application and meaning of the tones and announcements are a national matter and outside the scope of this ETS.

A description of the relation between the different elements described in this ETS can be found in annex A.

5.2 Basic facilities

5.2.1 Audio facilities

The audio system shall be designed to offer handsfree communication to two or more participants at each site. The participants should be allowed to listen and speak simultaneously. The speech transmission bandwidth shall nominally be 7 kHz, although this may be reduced when the conference has been opened to participants served by a non-ISDN network.

5.2.2 Conference control facility

A conference control system for governing call establishment and call termination, controlling conference modes and audio/image signals; and for transmission of conference control signals (e.g. floor requests, tokens), shall be provided.

The conference control system shall, as a minimum, be based on the signals and procedures specified in ETS 300 144 [3] and ETS 300 143 [7]. For improved performance the Multipoint Communication Service (MCS) as described in ITU-T Recommendation T.122 [8] using the Generic Conference Control protocols described in ITU-T Recommendation T.124 [9] can be used.

5.2.3 Data transmission facility

A data transmission facility shall be provided. The facility shall be based on data channels as defined in ETS 300 144 [3]. For improved performance the protocol stack defined in ITU-T Recommendation T.123 [10] should be implemented.

5.2.4 Graphics facility

The graphics system shall be designed to transmit documents, charts, diagrams, etc., during the conference.

NOTE: As a minimum, a facsimile group 3 transmission in a separate B-channel should be available.

5.3 Other facilities

As options, other facilities can be provided as applications using the MCS specified in ITU-T Recommendation T.122 [8]. Examples are:

- still picture;

NOTE 1: ITU-T Recommendation T.126 specifies a Multipoint still image and annotation protocol.

- file transfer.

NOTE 2: ITU-T Recommendation T.127 specifies a Multipoint binary file transfer protocol.

6 Procedures

6.1 Provision and withdrawal

The audiographic conference shall either be provided after prior arrangement with the service provider, or shall be generally available.

NOTE: As a service provider option, the audiographic conference teleservice can be offered with several subscription options which apply separately to each ISDN number, or groups of ISDN numbers on the interface. For each subscription option, only one value can be selected.

It should be noted that in this context an interface may consist of a group of physical interfaces.

Subscription options for the interface are summarised in table 1.

Table 1

Subscription option	Value
Maximum number of information channels available	m: where m is not greater than the number of information channels on the interface.
Maximum number of total calls present	n: where n is not greater than the number of information channels on the interface.

The user can be identified by an ISDN number or a group of ISDN numbers, or globally for all ISDN numbers on the interface.

More than one ISDN number can be associated with the interface as a part of a supplementary service such as the multiple subscriber number supplementary service. In the case of one ISDN number, the option given in table 1 for the number of calls can only exceed the number of information channels in association with a supplementary service (e.g. the call waiting supplementary service). As a network provider option, separate values may be specified for incoming and for outgoing calls for either or both of the limits.

6.2 Normal procedures

For case a) of the audiographic conference teleservice, communication is by means of a single 64 kbit/s connection, and as a result a single call shall be established. The procedures are given in subclause 6.2.1.

For case b) of the audiographic conference teleservice, communication is by means of two or more 64 kbit/s connections, and as a result two or more calls shall be established. For the establishment of the first call, the procedures of subclause 6.2.1 shall apply. The subsequent calls shall be established using the procedures given in subclause 6.2.1, provided that the first call has already been established.

The network shall provide out of band indications to indicate call progress. Network generated tones and/or announcements shall be provided for the audiographic conference teleservice.

6.2.1 Originating the call (call establishment)

The audiographic conference teleservice is originated by the originating user activating the terminal, performing the service selection, if applicable for the originating terminal, and terminating selection. During this process, the originating user shall be given the appropriate indications as to the state of the call.

The end-to-end path is framed according to ETS 300 144 [3]. The inband protocol shall be established according to ETS 300 143 [7].

Call 1 shall be established before initiating Call 2.

NOTE 1: Call 1 is devoted to transfer of speech and data. The transmission audio mode on the end-to-end digital path is defined according to ETS 300 144 [3], using the procedures defined in ETS 300 143 [7].

Audio tones provided to the user during Call 1 shall be as for the telephony 3,1 kHz teleservice, given in ETS 300 111 [4].

The subsequent calls can only be originated by the calling user's terminal after the connection has been established on Call 1 and after the end-to-end mode initialisation procedure is completed.

NOTE 2: The subsequent calls are devoted to data communication.

6.2.2 Indications during call establishment

At the called side the calls shall be accepted after successful checking of compatibility information by the terminal(s) addressed.

After initiating Call 1 the calling user shall receive an acknowledgement that the network is able to process the call. The called user shall receive an indication of the arrival of an incoming audiographic conference call. The calling user shall also be given an indication that the call is being offered to the called user, when an indication is received by the network that the called user is being informed of this call.

The acceptance of Call 1 by the called user (answer), shall cause the indications to be removed and the bi-directional communication path to be provided.

After initiating each subsequent call, the calling user shall receive an acknowledgement that the network is able to process the call. The called user shall receive an indication of the arrival of an incoming audiographic conference call.

The acceptance of the subsequent calls by the called user (answer), shall cause the bi-directional communication path to be provided.

6.2.3 Terminating the conference

6.2.3.1 Point-to-point conference

A request to terminate the audiographic conference teleservice can be generated by either of the users. If one user terminates the service, the other user(s) shall be given an appropriate indication.

6.2.3.2 Multipoint conference

A request to terminate the call(s) can be generated by either the user or the MCU controlled by the MCU director or the user given the Chair control described in ITU-T Recommendation H.243 [22]. If one user terminates his call to the MCU, the other user(s) shall be given an appropriate indication.

The termination of the whole conference shall be controlled by the MCU or by the user given the Chair-control.

NOTE: An MCU could be designed to establish the call to a given user if this connection is unintentionally released.

6.2.4 Change of communication mode

As a result of end-to-end integrity on the audiographic conference teleservice, 3,1 kHz telephony calls and 7 kHz telephony calls, it shall be possible to change between different communication modes according to ETS 300 143 [7].

Depending on the terminal capabilities, it may be possible to change between the following communication modes:

- 3,1 kHz speech (CCITT Recommendation G.711 [11]);
- 3,1 kHz speech (ITU-T Recommendation G.728 [6]) and data (option);
- 7 kHz speech (CCITT Recommendation G.722 [12]);
- 7 kHz speech (CCITT Recommendation G.722 [12]) and data.

6.2.5 Multipoint control

To allow communication between three or more audiographic conference terminals a MCU shall be used. The MCUs may be cascaded (Multiple MCU configuration) as specified in ETS 300 483 [13], when required by a particular conference. The procedures for establishing connections between MCUs can follow the principles for establishing connections between a MCU and a terminal.

The MCU in the audiographic conference teleservice shall provide the following:

- a) user access and network interface;
- b) management of framing structure: multiplexing and demultiplexing;
- c) mixing or switching of audio signals;
- d) processing of the sub-channels;
- e) analysis of control messages;
- f) routing of signals to audiographic terminals or other MCUs;
- g) handling of encrypted signals (option);
- h) terminal interconnection.

The connections between a MCU and the users participating in the conference shall be established by:

- the MCU calling the user (dial out);
- the user calling the MCU (dial in).

When the dial-in procedure is used, the MCU should provide an optional control system to prevent unauthorized access to the conference.

6.2.6 Data communication

The data transmission facility provides means for transmission of additional control information (e.g. chair control functions), transmission of user information, communication between PCs, etc. Protocols for data transmission and conference control are specified in the ITU-T T.120 series of recommendations.

NOTE: An overview of the ITU-T T.120 series of recommendations is presented in ITU-T Recommendation T.120.

6.3 Exceptional procedures

6.3.1 Situations at the calling user side

When the network receives an improper service request from the user, the network shall give that user the appropriate failure indication and the call establishment shall be ceased.

A user inputting an invalid ISDN number shall be given an appropriate failure indication by the network and the call establishment shall be ceased.

6.3.2 Situations at the called user side

A calling user attempting to establish a call to a user who is identified by the network to be busy (either network determined user busy or user determined user busy) shall be given an appropriate failure indication by the network.

A user attempting to establish a call to a user whose terminal equipment fails to respond shall be given an appropriate failure indication by the network and the call establishment shall be ceased.

On a call to a user whose terminal equipment has responded that the called user is being informed of the call, but has failed to establish the connection within a defined time, the calling user attempting to establish the call shall be given an appropriate failure indication by the network and the call establishment shall be ceased.

6.3.3 Situations due to network conditions

A user attempting to establish a call, but meeting problems due to network conditions (e.g. congestion) shall be given the appropriate indication by the network.

6.3.4 Retention of call information

If a user attempts to establish a call, but meets problems due to network conditions (e.g. congestion) or called user state (e.g. network determined user busy or user determined user busy) then, according to a network option, the network shall retain all the information supplied by the calling user for the duration of the retention timer.

7 Intercommunication and interworking considerations

Intercommunication of audiographic conference terminals with 3,1 kHz and 7 kHz ISDN terminals, and interworking with the Public Switched Telephone Network (PSTN) shall be provided.

The audiographic conference teleservice shall include voice encoding according to CCITT Recommendations G.711 [11] and G.722 [12], and as an option, voice encoding according to CCITT Recommendation G.728 [6].

The user of an audiographic conference terminal shall be able to establish calls to 3,1 kHz and 7 kHz terminals connected to the ISDN and to telephone terminals connected to the PSTN.

Audiographic conference terminals shall be able to accept calls from 3,1 kHz and 7 kHz terminals connected to the ISDN and from telephone terminals connected to the PSTN.

NOTE: As a terminal option, audiographic conference terminals may be pre-programmed to accept incoming audiographic conference calls only.

7.1 Fall-back procedures

7.1.1 Fall-back to the telephony 3,1 kHz teleservice

7.1.1.1 Procedures

Fall-back to telephony 3,1 kHz teleservice shall be an inherent feature of the audiographic conference teleservice. If the calling user indicates that fall-back is not allowed when originating a call, fall-back procedures shall not apply.

NOTE 1: This situation may lead to an unsuccessful call attempt due to called user terminal capabilities.

If the calling user has not indicated that fall-back is not allowed, then the following procedure shall apply:

- the network shall offer the call to the called user at all audiographic conference, 7 kHz and 3,1 kHz terminals. The called user can accept the call either as an audiographic conference, 7 kHz or 3,1 kHz telephone call at any terminal where the call is offered;
- the calling user shall be informed of the resultant telecommunications service, i.e. the audiographic conference, telephony 7 kHz or the telephony 3,1 kHz teleservice;
- if no terminal accepts the call, this shall be indicated to the calling user.

NOTE 2: Echo cancellation will be disabled for audiographic conference calls. If fall-back to telephony 3,1 kHz teleservice occurs re-enabling of echo cancellers is needed. However, some networks may not support the corresponding signalling mechanism.

NOTE 3: When fall-back is not implemented by the network, fall-back may be performed end-to-end by the calling audiographic conference terminal by originating a new call.

If the calling user has not indicated that fall-back is not allowed and the network does not support the fall-back procedure, the telephony 3,1 kHz teleservice shall be provided to the calling user.

7.1.1.2 Interworking with non-ISDNs

If the calling user has not indicated that fall-back is not allowed and interworking with the PSTN occurs, the telephony 3,1 kHz teleservice shall be provided. The calling user shall be informed of this situation.

If fall-back is not allowed for the call, the communication is not established.

7.1.2 Fall-back to the telephony 7 kHz teleservice

In the case where the calling user has not indicated that fall-back is not allowed, i.e. fall-back to the telephony 3,1 kHz teleservice is allowed, the call can be accepted by the called user on a 7 kHz telephone terminal.

The calling user shall be informed of the resultant telecommunications service, i.e. the telephony 7 kHz teleservice.

7.2 Interworking with private ISDNs

General information on the situation where the communicating users are attached to a private ISDN and a public ISDN is given in ETS 300 345 [14].

If the calling user has not indicated that fall-back is not allowed and the called user is connected to a private ISDN that supports the audiographic conference teleservice, then, in situations where fall-back applies, the fall-back procedures shall be performed by the private ISDN.

The result of call presentation (the audiographic conference, telephony 7 kHz or telephony 3,1 kHz teleservice) within the private ISDN shall be indicated to the public ISDN.

In the case where the private ISDN does not support the fall-back procedures, then the telephony 3,1 kHz teleservice shall be provided. The calling user shall receive an indication from the public ISDN that fall-back to the telephony 3,1 kHz teleservice has occurred.

MCUs may be located in a private ISDN.

7.3 Restricted network operation

All terminals for the audiographic conference teleservice shall be capable of interoperation with terminals connected to restricted networks: that is, networks which provide connections at 56 kbit/s, or at multiples of 64 kbit/s with a ones density restriction, as described in ETS 300 144 [3].

In order to effect such interoperation, the procedures included in clause 13 of ITU-T Recommendation H.242 [15] shall be implemented.

8 Interaction with other supplementary services

Each supplementary service description identifies the applicability with the audiographic conference teleservice.

If the inband communication is interrupted by the network as a result of one user invoking a supplementary service (e.g. call hold supplementary service, or terminal portability supplementary service) the network shall provide an appropriate indication (e.g. all ones or idle signal) in the B-channel.

Before invoking supplementary services that interrupt the inband signalling communication (e.g. the call hold supplementary service), the inband communication shall revert to mode 0, as described in ETS 300 143 [7].

Applicability of supplementary services is described in annex B.

9 Static description of the service using attributes

The attributes are defined in CCITT Recommendation I.140 [16], annex A, subclause A.1.1.

The values of the attributes are defined in CCITT Recommendation I.140 [16], annex A, clause A.2.

9.1 Low layer attributes

The information transfer attributes of this teleservice are specified in table 2 and table 3.

Table 2: Values for information transfer attributes for call 1

Attribute	Possible values
Information transfer mode	- circuit
Information transfer rate	- 64 kbit/s
Information transfer capability	- unrestricted Digital Information with tones and announcement - speech (note)
Structure	- 8 kHz integrity
Establishment of communication	- demand
Symmetry	- bi-directional symmetric
Communication configuration	- point-to-point - multipoint
NOTE:	In the case where fall-back to the telephony 3,1 kHz teleservice applies, the information transfer capability shall be speech.

Table 3: Values for information transfer attributes for call 2 and subsequent calls

Attribute	Possible values
Information transfer mode	- circuit
Information transfer rate	- 64 kbit/s
Information transfer capability	- unrestricted Digital Information
Structure	- 8 kHz integrity
Establishment of communication	- demand
Symmetry	- bi-directional symmetric
Communication configuration	- point-to-point - multipoint

9.2 Access attributes

The access attributes of this teleservice are specified in table 4 and table 5.

Table 4: Values of access attributes for call 1

Attribute	Possible values
Access channel and rate	User information - B (64 kbit/s) Signalling - D (16 kbit/s or 64 kbit/s)
Signalling access protocol, information (note)	User information - ETS 300 143 [7], ETS 300 144 [3], CCITT Recommendations G.711 [11], G.722 [12], G.728 [6] and ITU-T Recommendations H.243 [22], T.122 [8], T.123 [10], T.124 [9] and T.125 [23]. Signalling - ETS 300 011 [17], ETS 300 012 [18], ETS 300 403-1 [19], ETS 300 402-1 [20], ETS 300 267-1 [21]
NOTE:	Depending on the application, more user information attributes may be applicable.

Table 5: Values of access attributes for call 2 and subsequent calls

Attribute	Possible values
Access channel and rate	User information - B (64 kbit/s) Signalling - D (16 kbit/s or 64 kbit/s)
Signalling access protocol, information (note)	User information - ETS 300 143 [7], ETS 300 144 [3] ITU-T Recommendations H.243 [22], T.122 [8], T.123 [10], T.124 [9] and T.125 [23]. Signalling - ETS 300 011 [17], ETS 300 012 [18], ETS 300 403-1 [19], ETS 300 402-1 [20], ETS 300 267-1 [21]
NOTE: Depending on the application, more user information attributes may be applicable.	

9.3 High layer attributes

For call 1

Type of user information: speech, data, control and indication.

Layer 4 protocol functions: ITU-T Recommendation T.123 [10].

Layer 5 protocol functions: ITU-T Recommendation T.123 [10].

NOTE 1: The layer 5 protocol functions is an option in the ISDN extended profile specified in ITU-T Recommendation T.123 [10].

Layer 6 protocol functions: CCITT Recommendations G.711 [11] and G.722 [12] and ITU-T Recommendations G.728 [6] and T.123 [10].

NOTE 2: The layer 6 protocol functions is an option in the ISDN extended profile specified in ITU-T Recommendation T.123 [10].

Layer 7 protocol functions: ITU-T Recommendations T.122 [8], T.124 [9] and T.125 [23].

For call 2

Type of user information: data, graphics, still image control and indication.

Layer 4 protocol functions: ITU-T Recommendation T.123 [10].

Layer 5 protocol functions: ITU-T Recommendation T.123 [10].

NOTE 3: The layer 5 protocol functions is an option in the ISDN extended profile specified in ITU-T Recommendation T.123 [10].

Layer 6 protocol functions: ITU-T Recommendation T.123 [10].

NOTE 4: The layer 6 protocol functions is an option in the ISDN extended profile specified in ITU-T Recommendation T.123 [10].

Layer 7 protocol functions: ITU-T Recommendations T.122 [8], T.124 [9] and T.125 [23].

NOTE 5: Depending on the application, more high layer attributes may be applicable.

9.4 General attributes

This ETS does not provide values for general attributes.

Annex A (informative): Relation between standards and recommendations relevant for the audiographic conference service

The following figure describes the relation between those standards and recommendations relevant for the audiographic conference service.

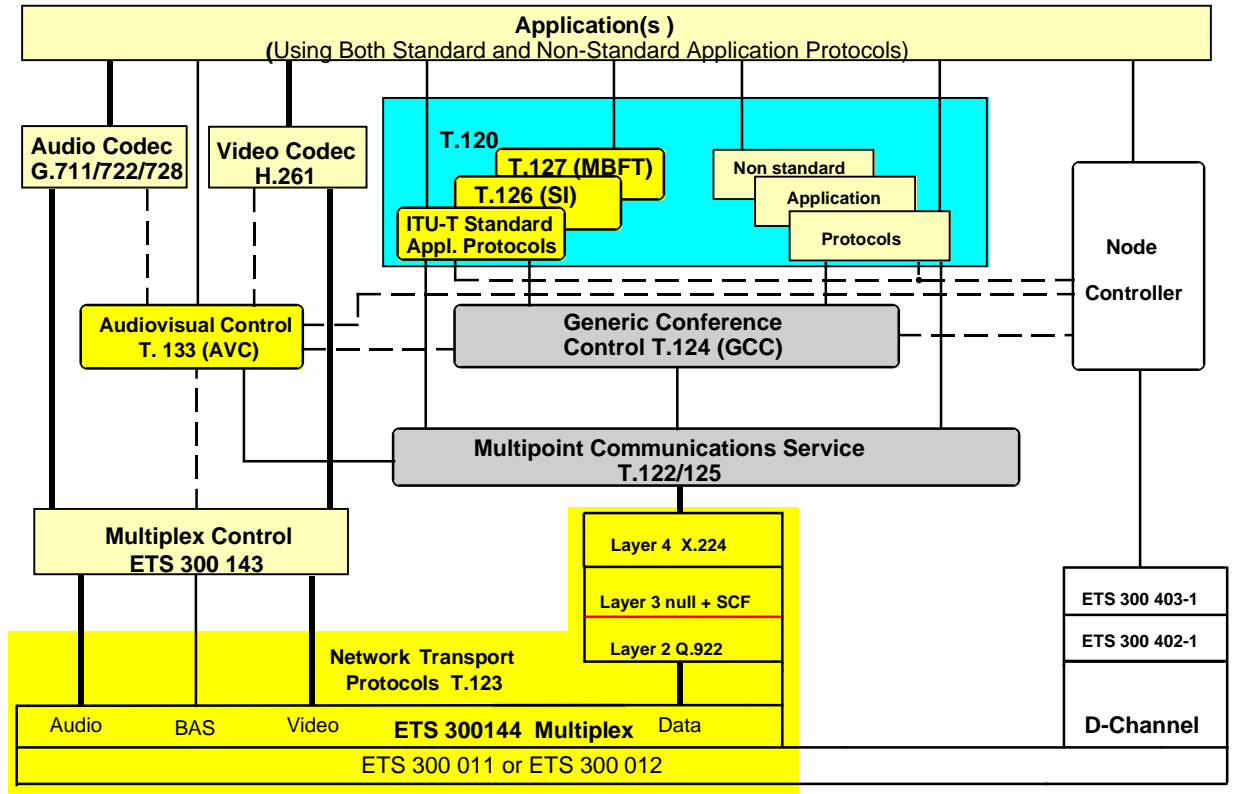

Figure A.1

Annex B (informative): Applicability of supplementary services to the audiographic conference teleservice

B.1 General

The applicability of the following supplementary services to the audiographic conference teleservice is for further study:

- the call hold supplementary service;
- the explicit call transfer supplementary service;
- the terminal portability supplementary service.

The following supplementary services are not applicable for the audiographic conference teleservice:

- the conference call, add-on supplementary service;
- the meet-me conference supplementary service;
- the three party supplementary service.

A similar functionality can be obtained using a MCU.

B.2 Audiographic conference based on one circuit-mode 64 kbit/s connection

There is no additional requirement for the application of the following supplementary services:

- the advice of charge services:
 - the advice of charge: charging information at call set-up time supplementary service;
 - the advice of charge: charging information during the call supplementary service;
 - the advice of charge: charging information at the end of a call supplementary service;
- the call waiting supplementary service;
- the number identification services:
 - the calling line identification presentation supplementary service;
 - the calling line identification restriction supplementary service;
 - the connected line identification presentation supplementary service;
 - the connected line identification restriction supplementary service;
- the completion of calls to busy subscribers supplementary service;
- the direct dialling-in supplementary service;
- the malicious call identification supplementary service;
- the multiple subscriber number supplementary service;
- the subaddressing supplementary service;
- the user-to-user signalling supplementary service.

Concerning the closed user group supplementary service, in order to ensure the integrity of the closed user group supplementary service, when fall-back occurs, the closed user groups subscribed to for the audiographic conference teleservice also applies to for the fall-back connection.

For the call diversion supplementary services, the call will be diverted as a call using the audiographic conference teleservice. If the calling user has not indicated that fall-back is not allowed, the fall-back indication will be included when the diverted part of the call is originated. The calling user will be informed of fall-back when it occurs.

The indication that fall-back has occurred will be sent to the calling user independently of the value of the diverting user's subscription option that the calling user is informed that the call has been diverted.

B.3 Audiographic conference based on two or more circuit-mode 64 kbit/s connections

In general, each call will be handled separately. The information presented in clause B.2 is valid except from the call diversion supplementary services which require further study.

Annex C (informative): Bibliography

For the purposes of this ETS, the following documents have been given for information:

- CCITT Recommendation I.130 (1985)88): "Method for the characterisation of telecommunication services supported by an ISDN and network capabilities of an ISDN".
- CCITT Recommendation I.210 (1985)88): "Principles of telecommunication services supported by an ISDN and the means to describe them".
- CCITT Recommendation E.164 (1985)91): "Numbering plan for the ISDN era".
- ITU-T Recommendation T.120: "Data Protocols for Multimedia Conferencing".
- ITU-T Recommendation T.126: "Multipoint still image and annotation protocol".
- ITU-T Recommendation T.127: "Multipoint binary file transfer protocol".
- ITU-T Recommendation X.224 (1985)93): "Protocol for providing the OSI connection-mode transport service".
- ITU-T Recommendation X.225 (1985)94): "Information technology - Open Systems Interconnection - Connection-oriented session protocol: Protocol specification".
- ITU-T Recommendation X.226 (1985)94): "Information technology - Open Systems Interconnection - Connection-oriented presentation protocol: Protocol specification".
- CCITT Recommendation X.227 (1985)92): "Connection-oriented protocol specification for the association control service element".
- CCITT Recommendation Q.922 (1985)92): "ISDN data link layer specification for frame mode bearer services".

History

Document history			
September 1995	Public Enquiry	PE 92:	1995-09-25 to 1996-01-19
August 1996	Vote	V 109:	1996-08-12 to 1996-10-18