



EUROPEAN
TELECOMMUNICATION
STANDARD

FINAL DRAFT
pr **ETS 300 638**

August 1996

Source: ETSI TC-TM

Reference: DE/TM-04022

ICS: 33.060.30

Key words: point-to-point, radio, transmission, DRRS, SDH

**Transmission and Multiplexing (TM);
Fixed point-to-point radio link equipment for the
transmission of digital signals and analogue video signal
operating in frequency bands with 20 MHz alternate
channel spacing**

ETSI

European Telecommunications Standards Institute

ETSI Secretariat

Postal address: F-06921 Sophia Antipolis CEDEX - FRANCE

Office address: 650 Route des Lucioles - Sophia Antipolis - Valbonne - FRANCE

X.400: c=fr, a=atlas, p=etsi, s=secretariat - **Internet:** secretariat@etsi.fr

Tel.: +33 92 94 42 00 - Fax: +33 93 65 47 16

Copyright Notification: No part may be reproduced except as authorized by written permission. The copyright and the foregoing restriction extend to reproduction in all media.

© European Telecommunications Standards Institute 1996. All rights reserved.

Contents

Foreword	5
1 Scope	7
2 Normative references	7
3 Abbreviations and symbols	8
3.1 Abbreviations	8
3.2 Symbols	9
4 General characteristics (digital and analogue)	9
4.1 Frequency bands and channel arrangements	9
4.1.1 Alternate channel spacing	9
4.1.2 Transmit/receive minimum separation	9
4.1.3 Transmit/receive duplex frequency separation	9
4.2 Compatibility requirements between systems.....	9
4.3 Types of installation	10
4.3.1 Environmental conditions	10
4.3.1.1 Equipment within weatherprotected locations	10
4.3.1.2 Equipment for non-weatherprotected locations	10
4.3.2 ElectroMagnetic Compatibility (EMC).....	11
4.4 System block diagram	11
4.5 TMN interface	11
4.6 Power supply.....	11
4.7 Receiver Intermediate frequency	12
5 Parameters for digital systems.....	12
5.1 Transmission capacity	12
5.2 Applications.....	12
5.3 Baseband parameters	12
5.3.1 Plesiochronous interfaces	12
5.3.2 SDH baseband interface	12
5.4 Transmitter characteristics	12
5.4.1 Transmitter power range	12
5.4.2 Automatic Transmit Power Control (ATPC)	12
5.4.3 RF spectrum.....	13
5.4.3.1 RF spectrum mask	13
5.4.3.2 Spectral line at the symbol rate	14
5.4.4 Spurious emissions	14
5.4.4.1 Spurious emissions-external	15
5.4.4.2 Spurious emissions-internal	15
5.4.5 Radio frequency tolerance	15
5.5 Receiver characteristics.....	16
5.5.1 Input level range	16
5.5.2 Spurious emissions	17
5.5.2.1 Spurious emissions external.....	17
5.5.2.2 Spurious emissions-internal	18
5.6 System characteristics without diversity	18
5.6.1 BER performance.....	18
5.6.2 Equipment background BER.....	18
5.6.3 Interference sensitivity.....	18
5.6.4 Distortion sensitivity.....	19
5.7 System characteristics with diversity	19
5.7.1 Differential delay compensation	19
5.7.2 BER performance.....	19
6 Parameters for wideband analogue systems	19

6.1	Transmit/receive capacity	19
6.1.1	Applications	20
6.2	Baseband parameters.....	20
6.2.1	Video Interfaces.....	20
6.2.2	Audio interface (if applicable)	20
6.2.3	Digital interface (if applicable).....	20
6.2.4	IF interface (if applicable)	20
6.2.5	Transmission performance.....	20
6.3	Transmitter characteristics.....	20
6.3.1	Transmitter power range	20
6.3.2	Transmitter output power tolerance.....	20
6.3.3	Radiated spectrum.....	21
6.3.3.1	Spectrum masks	21
6.3.3.2	Frequency deviation.....	21
6.3.4	Spurious emissions.....	22
6.3.4.1	Spurious emissions-external.....	22
6.3.4.2	Spurious emissions-internal.....	22
6.3.5	Radio frequency tolerance.....	23
6.4	Receiver characteristics	23
6.4.1	Input level range	23
6.4.2	Spurious emissions.....	23
6.4.2.1	Spurious emissions-external.....	23
6.4.2.2	Spurious emissions-internal.....	23
6.4.3	Noise figure.....	23
6.5	System performance	24
6.5.1	Receiver threshold.....	24
6.5.2	Interference sensitivity	24
Annex A (informative):	Automatic Transmit Power Control (ATPC).....	25
Annex B (informative):	Example of a channel plan for 20 MHz alternate channel spacing in the 10 GHz and 14 GHz frequency band.....	26
History		27

Foreword

This European Telecommunication Standard (ETS) has been produced by the Transmission and Multiplexing (TM) Technical Committee of the European Telecommunications Standards Institute (ETSI) and is now submitted for the Voting phase of the ETSI standards approval procedure.

This ETS contains the minimum technical requirements to ensure compatibility of products and conformance with radio regulations across ETSI member states. Radio terminals from different manufacturers are not required to interwork at radio frequency (i.e. no common air interface). However, terminals may be combined with other manufacturers equipment on a Radio Frequency (RF) branching network for operation on different polarizations.

This final draft ETS defines the requirements of radio terminal and radio relay equipment and associated interfaces. The requirements for multiplex, network management and antenna/feeder equipment may be addressed elsewhere.

Proposed transposition dates	
Date of latest announcement of this ETS (doa):	3 months after ETSI publication
Date of latest publication of new National Standard or endorsement of this ETS (dop/e):	6 months after doa
Date of withdrawal of any conflicting National Standard (dow):	6 months after doa

Blank page

1 Scope

This European Telecommunication Standard (ETS) covers the minimum performance requirements for terrestrial fixed services radio communications equipment, as given below, in bands in the frequency ranges 10 GHz and 14 GHz using 20 MHz channel spacing.

This ETS is applicable in those countries where the frequency plan in these bands is based on a 20 MHz spacing; it does not prevent the development of future ETSs for equipment operated in these bands using a different channel plan.

This ETS does not cover aspects related to test procedures and test conditions which are in the scope of another ETS under production in TM4 (DE/TM 04026-01).

The parameters specified fall into two categories:

- a) those required to provide compatibility between channels from different sources of equipment on the same route, connected either to separate antennas, or to separate polarizations of the same antenna. This category also includes parameters providing compatibility with the existing radio-relay network;
- b) parameters defining the transmission quality of the proposed systems.

The standardization includes the following specifications:

- transmitter and receiver characteristics;
- baseband and RF interface characteristics;
- diversity system characteristics.

As regards Synchronous Digital Hierarchy (SDH) systems, the Section Overhead (SOH) processing is covered in CCIR Recommendation 750 [8].

Safety aspects are outside the mandate of ETSI and they will not be considered in this ETS.

2 Normative references

This ETS incorporates by dated or undated reference, provisions from other publications. These normative references are cited at the appropriate places in the text and the publications are listed hereafter. For dated references, subsequent amendments to or revisions of any of these publications apply to this ETS only when incorporated in it by amendment or revision. For undated references, the latest edition of the publication referred to applies.

- | | |
|-----|-------------------------------------------------------------------------------------------------------------------------------------------------------------------------------------------------------------|
| [1] | ETS 300 019 (1994): "Equipment Engineering (EE); Environmental conditions and environmental tests for telecommunications equipment". |
| [2] | ETS 300 132: "Equipment Engineering (EE); Power supply interface at the input to telecommunications equipment". |
| [3] | ETS 300 385 (1995): "Radio Equipment and Systems (RES); " ElectroMagnetic Compatibility (EMC) Standard for digital fixed radio links and ancillary equipment with data rates at around 2 Mbit/s and above". |
| [4] | CCIR Recommendation 401-2: "Frequencies and deviations of continuity pilots for frequency modulation radio-relay systems for television and telephony". |
| [5] | CCIR Recommendation 403-3: "Intermediate frequency characteristics for the interconnection of analogue radio-relay systems". |
| [6] | CCIR Recommendation 405-1: "Pre-emphasis characteristics for frequency modulation radio-relay systems for television". |

- [7] CCIR Recommendation 746: "Radio - Frequency channel arrangements for radio-relay systems - Annex 7: Description of the radio-frequency channel arrangement in the frequency band 14,25-14,5 GHz using a 20 MHz channel spacing".
- [8] CCIR Recommendation 750: "Architectures and functional aspects of radio-relay systems for SDH-based networks".
- [9] CCIR Recommendation 751: "Transmission characteristics and performance requirements of radio-relay systems for SDH-based networks".
- [10] ITU-T Recommendation J.61: "Transmission performance of television circuits designed for use in international connections".
- [11] ITU-T Recommendation J.21: "Performance characteristics of 15 kHz-type sound-programme circuits - Circuits for high quality monophonic and stereophonic transmissions".
- [12] CCITT Recommendation G.703: "Physical/electrical characteristics of hierarchical digital interfaces".
- [13] ITU-T Recommendation G.707: "Network node interface for the Synchronous Digital Hierarchy".
- [14] ITU-T Recommendation G.773: "Protocol suites for Q-interfaces for management of transmission systems".
- [15] ITU-T Recommendation G.784: "Synchronous Digital Hierarchy (SDH) management".

3 Abbreviations and symbols

3.1 Abbreviations

For the purposes of this ETS, the following abbreviations apply:

ATPC	Automatic Transmitter Power Control
BB	BaseBand
BER	Bit Error Rate
C/I	Carrier to Interference Ratio
CW	Continuous Wave
DRRS	Digital Radio-Relay System
EMC	ElectroMagnetic Compatibility
IF	Intermediate Frequency
IF/RF	Intermediate Frequency/Radio Frequency
LO	Local Oscillator
PDH	Plesiochronous Digital Hierarchy
PRBS	Pseudo-Random Binary Sequence
RF	Radio Frequency
RSL	Received Signal Level
RX	Receive (Receiver)
SDH	Synchronous Digital Hierarchy
S/I	Signal to Interference Ratio
SRL	Spectrum Reference Level
STM-1	Synchronous Transport Module-level 1
TMN	Telecommunications Management Network
TX	Transmit (Transmitter)

3.2 Symbols

For the purposes of this ETS, the following symbols apply:

dB	decibel
dBm	decibel relative to 1 mW
GHz	Gigahertz
km	kilometre
Mbit/s	Mega-bit per second
MHz	Megahertz
m/s	metres per second
ppm	parts per million
ns	nanosecond
W/m ²	Watts per square metre

4 General characteristics (digital and analogue)

4.1 Frequency bands and channel arrangements

The systems shall be required to operate in the frequency bands 10 GHz or 14 GHz using a channel spacing of 20 MHz according to ITU-R Recommendation 746 [7].

NOTE: A typical application of ITU-R Recommendation 746 [7] is shown in annex B.

4.1.1 Alternate channel spacing

See subclause 4.2, a).

Table 1a: Digital systems

Minimum bit rate (Mbit/s)	2 x 34 (note)	2 x 45 (note)	2 x 51
Channel spacing (MHz)	20	20	20
NOTE: In order to achieve good efficiency a minimum gross bit rate of about 90 Mb/s is envisaged; therefore n x 2 Mbit/s way side traffic in Plesiochronous Digital Hierarchy (PDH) systems is considered.			

Table 1b: Analogue systems

Video baseband (MHz)	≤ 10
Channel spacing (MHz)	20

4.1.2 Transmit/receive minimum separation

The minimum separation between the centre frequencies of the closest go and return radio channels shall be 30 MHz.

4.1.3 Transmit/receive duplex frequency separation

The transmitter receiver duplex frequency separation should be approximately half of the allocated frequency band. An example of a national channel plan in use is given in annex B for information.

4.2 Compatibility requirements between systems

- a) Systems operating on common hops will normally use the same double polarized antenna;
- b) there should be no requirement to operate transmitting equipment from one manufacturer with receiving equipment from another;

- c) there should be no requirement to multiplex equipment from different manufacturers on the same polarization of the same antenna.

4.3 Types of installation

Both indoor and partially outdoor installations are considered.

Single RF channel links connected to different polarizations of the same antenna via a polarization diplexer (mainly in a partially outdoor configuration) as well as multi RF channel links with classical RF filter channel branching units are anticipated.

4.3.1 Environmental conditions

The equipment shall be required to meet either the environmental conditions set out in ETS 300 019, part 1-3 and part 1-4 [1], which define weatherprotected and non-weatherprotected locations, classes and test severities, or one of the conditions listed in subclause 4.3.1.2.

4.3.1.1 Equipment within weatherprotected locations

The most important climatic parameters for the five classes defined are given in table 2.

Table 2: Climatic parameters (weatherprotected)

Climatic class	3.1	3.2	3.3	3.4	3.5
High air temperature (°C)	+40	+45	+55	+70	+40
Low air temperature (°C)	+5	-5	-25	-40	-40
High relative humidity (%)	85	95	100	100	100
Low relative humidity (%)	5	5	10	10	10
Air movement (m/s)	5	5	5	5	5
Solar radiation (W/m ²)	700	700	1x	1x	-

For equipment designed for stationary use in weatherprotected locations (indoor installation), only classes 3.1 or 3.2 shall apply (see ETS 300 019, part 1-3 [1]).

4.3.1.2 Equipment for non-weatherprotected locations

This type of equipment is generally described as "outdoor" equipment. Class 4.1 or extended class 4.1E parameters should be applied. Class 4.1 applies to many European countries and class 4.1E applies to them all. The most important parameters values are given in table 3.

Table 3: Climatic parameters (non-weatherprotected)

Climatic class	4.1	4.1E
High air temperature (°C)	+40	+45
Low air temperature (°C)	-33	-45
High relative humidity (%)	100	100
Low relative humidity (%)	15	8
Air movement (m/s)	+50	+50
Solar radiation (W/m ²)	1x	1x

It should be noted that radio cabinets supplied with a system will be "weather protected" including full protection against precipitation and wind. Climatic classes 3.3, 3.4 and 3.5 (subclause 4.3.1.1) may, therefore, also be applicable to equipment in outdoor locations.

The operation of the outdoor equipment in accordance with class 4.1E shall not be mandatory for all users of this ETS.

Some users of this ETS may also decide to apply one of the alternative parameters given in table 4.

Table 4: Alternative climatic parameters

Climatic class	4.1	4.1E
High air temperature (°C)	+40	+50
Low air temperature (°C)	-20	-30
High relative humidity (%)	90	90
Low relative humidity (%)	5	5
Air movement (m/s)	+50	+50
Solar radiation (W/m ²)	1x	1x

4.3.2 ElectroMagnetic Compatibility (EMC)

Digital systems shall operate under the conditions specified in the relevant EMC Standard for digital fixed links and ancillary equipment ETS 300 385 [3].

4.4 System block diagram

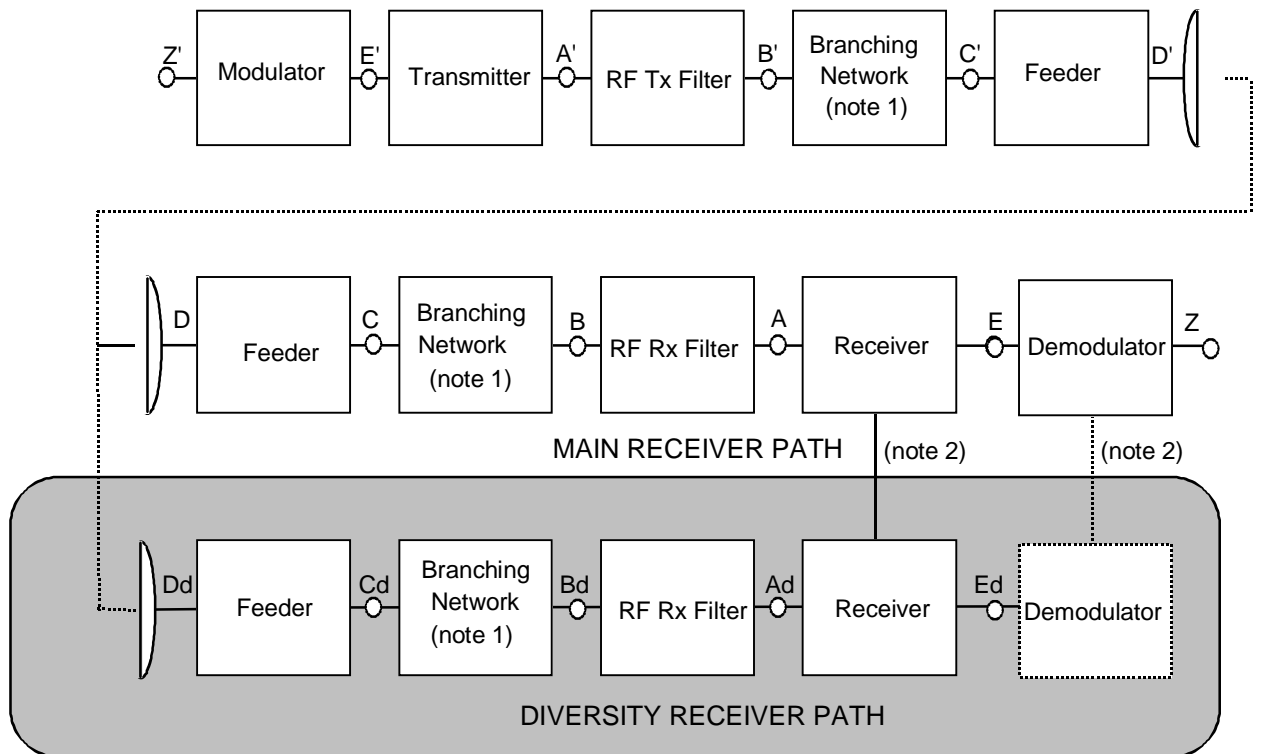

NOTE 1: No filtering included.

NOTE 2: Connection at RF, Intermediate Frequency (IF) or baseband.

Figure 1: System block diagram

4.5 TMN interface

For SDH equipment a Telecommunications Management Network (TMN) interface required by a user should follow ETSI, TM2 and TM3 recommendations in accordance with ITU-T Recommendations G.784 [15] and G.773 [14] and CCIR Recommendations 750 [8] and 751 [9]. For as Plesiochronous Digital Hierarchy (PDH) equipment the TMN interface is under study.

4.6 Power supply

The equipment shall operate from one or more of the supply voltages within the ranges specified in ETS 300 132 [2].

4.7 Receiver Intermediate frequency

The intermediate frequency, if accessible as a measurement point, shall be 70 MHz or 140 MHz.

5 Parameters for digital systems

5.1 Transmission capacity

Bit rates: 2 x 34 Mbit/s, 2 x 45 Mbit/s, 2 x 51 Mbit/s (sub-STM-1). Way-side traffic of $n \times 2$ Mbit/s is also considered for PDH systems.

For the transport of compressed digital video signals multiple lower bit rate signals (e.g. $n \times 8$ Mb/s) are envisaged as payloads, leading to similar gross transmission bit rates

In the following, the 2 x 34 Mbit/s and 2 x 45 Mbit/s systems will be indicated as PDH systems and the 2 x 51 Mbit/s system as an SDH system.

5.2 Applications

Medium capacity point-to-point local and regional networks, digital TV.

5.3 Baseband parameters

5.3.1 Plesiochronous interfaces

Plesiochronous interfaces shall comply with ITU-T Recommendation G.703 [12]. Service channels are outside the scope of this ETS.

5.3.2 SDH baseband interface

Whenever a synchronous interface is required for 2 x 51 Mbit/s (sub-Synchronous Transport Module - level 1 (STM-1)) systems, this shall be a standard STM-1 (ETSI TM3, VC4 - based) interface.

5.4 Transmitter characteristics

5.4.1 Transmitter power range

Nominal output power at point C' of the system block diagram (figure 1) shall be in the range +24 to +28 dBm.

A capability for output power level adjustment shall be provided. The range of this transmitter adjustment shall not be less than 20 dB, adjustable in increments of 5 dB or less.

The tolerance of the nominal output power shall be within:

- ± 3 dB: class 4.1E (subclause 4.3.1.2);
- ± 2 dB: all other classes (subclause 4.3.1.1 and 4.3.1.2).

NOTE: Limitation of the output power level in the band 10.6-10.68 must be taken into account according to Radio Regulations, article 8 footnote 831 (maximum EIRP = 40 dBW and the power delivered to the antenna shall not exceed -3 dBW).

5.4.2 Automatic Transmit Power Control (ATPC)

ATPC is an optional feature; information on ATPC is given in annex A.

The ATPC range shall not exceed 15 dB. When compatibility with analogue systems is required, the lowest power amplifier output level shall not be less than + 10 dBm; this may result in a reduced ATPC range.

5.4.3 RF spectrum

5.4.3.1 RF spectrum mask

The equipment shall comply with the digital RF power spectrum masks given in figure 2a or 2b as applicable.

Spectral lines at \pm symbol rate from the central carrier frequency may fall outside these masks.

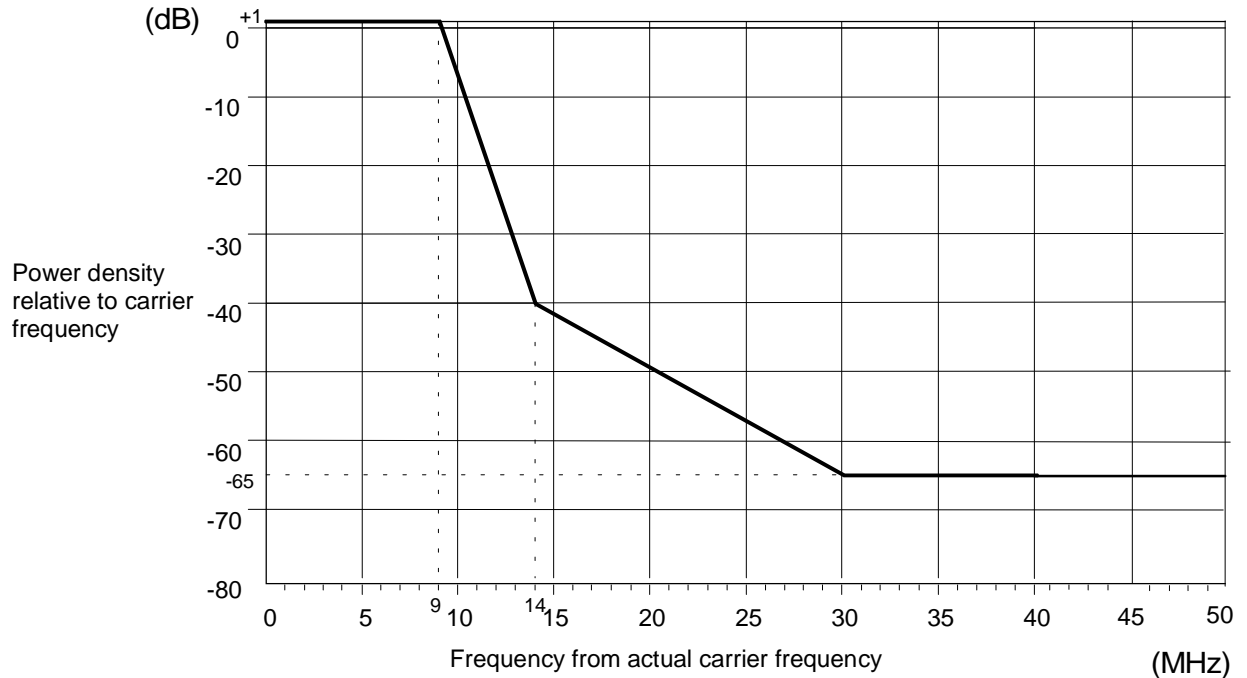

Figure 2a: Limits of spectral power density

The mask shall be measured with a modulating baseband signal. In the case of a PDH interface, a Pseudo-Random Binary Sequence (PRBS) of $2^{23} - 1$ at each input port shall be used. In the case of a SDH interface, a STM-1 test signal shall be defined.

The 0 dB level shown on the spectrum masks relates to the spectral power density of the nominal centre frequency disregarding residual carrier. The spectrum mask does not include frequency tolerance.

For the 14 GHz band, where the centre gap is 30 MHz, a mask is specified for the innermost edges of the centre gap channels 6 and 1' (referenced to point B'). The mask is shown in figure 2b.

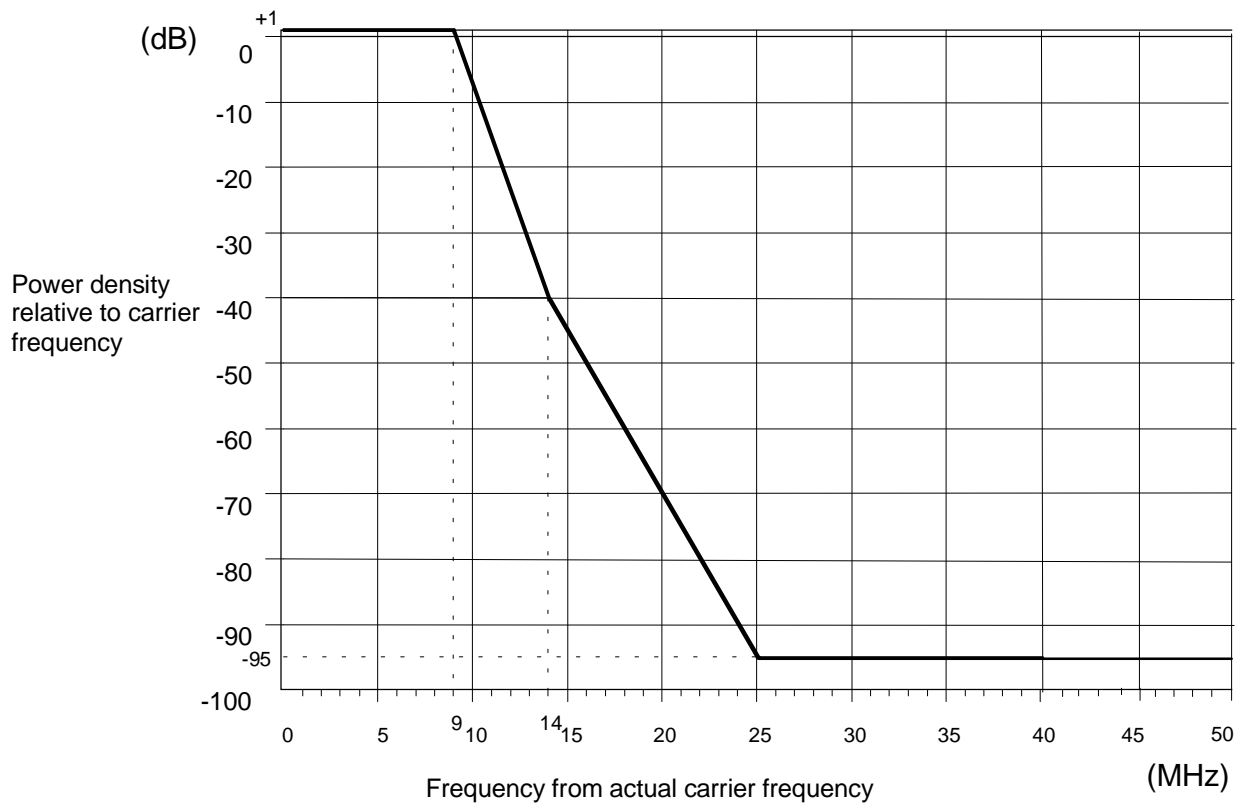

Figure 2b: Limits of spectral power density for the innermost channels, 14 GHz

The spectrum analyser settings for measuring the RF spectrum mask detailed in figures 2a and 2b are shown in table 5.

Table 5: Spectrum analyser settings for RF power spectrum measurement for digital systems

IF bandwidth	(kHz)	100
Video Bandwidth	(kHz)	0,3
Total scan time	(s)	20
Total sweep width	(MHz)	200

5.4.3.2 Spectral line at the symbol rate

The power level (reference point B') of spectral lines at a distance from the channel centre frequency equal to the symbol rate shall be less than -37 dBm.

5.4.4 Spurious emissions

It is necessary to define spurious emissions from transmitters for two reasons:

- a) to limit interference into systems operating wholly externally to the system;
- b) to limit local interference within the system where transmitters and receivers are directly connected via the filter and branching systems.

This leads to two sets of spurious emission limits where the specific limits given for "internal" interference are required to be no greater than the "external" level limits at point C'.

5.4.4.1 Spurious emissions-external

According to ITU-R the external spurious emissions are defined as emissions at frequencies which are outside the nominal carrier frequency $\pm 250\%$ of the relevant channel spacing.

The frequency range in which the spurious emissions specifications apply is 30 MHz to 45 GHz. The limit values referred at point C' are:

- 30 MHz to 21,2 GHz: -60 dBm in any 100 kHz Bandwidth (BW);
- 21,2 GHz to 45 GHz: -30 dBm in any 1 MHz BW.

The measuring bandwidth will be 100 kHz up to 21,2 GHz and 1 MHz above this limit.

For "noise-like" emissions, the limits are intended not to be exceeded in any elementary measuring bandwidth.

Within $\pm 250\%$ of the relevant channel spacing the unwanted emission level shall not exceed the limits fixed by the relevant spectrum mask.

5.4.4.2 Spurious emissions-internal

The levels of the spurious emissions from the transmitter, referenced to point B' are specified in table 6.

Table 6: Internal levels for transmitter spurious emissions

Spurious emission frequency relative to channel assigned frequency	Specification limit	Controlling factor for requirement applicaton
The average level of all spurious signals both discrete CW and noise-like (including	≤ -90 dBm	If spurious signal's frequency falls within receiver half band, for digital systems with multi-channel branching networks.
Local Oscillator (LO), \pm IF, $\pm 2 \times$ IF), evaluated as total signal level	≤ -70 dBm	If spurious signal's frequency falls within receiver half band, for digital systems without branching networks (i.e. with duplexer).
Other spurious evaluated as in subclause 5.4.4.1	≤ -45 dBm	If spurious signal's frequency falls within transmitter half band.

5.4.5 Radio frequency tolerance

A maximum radio frequency tolerance of ± 30 ppm shall apply.

5.5 Receiver characteristics

5.5.1 Input level range

The input level range (reference point C) at which the BER of 10^{-10} is not exceeded shall extend from the limit specified in figures 3 and 4 to the upper limit of at least -25 dBm .

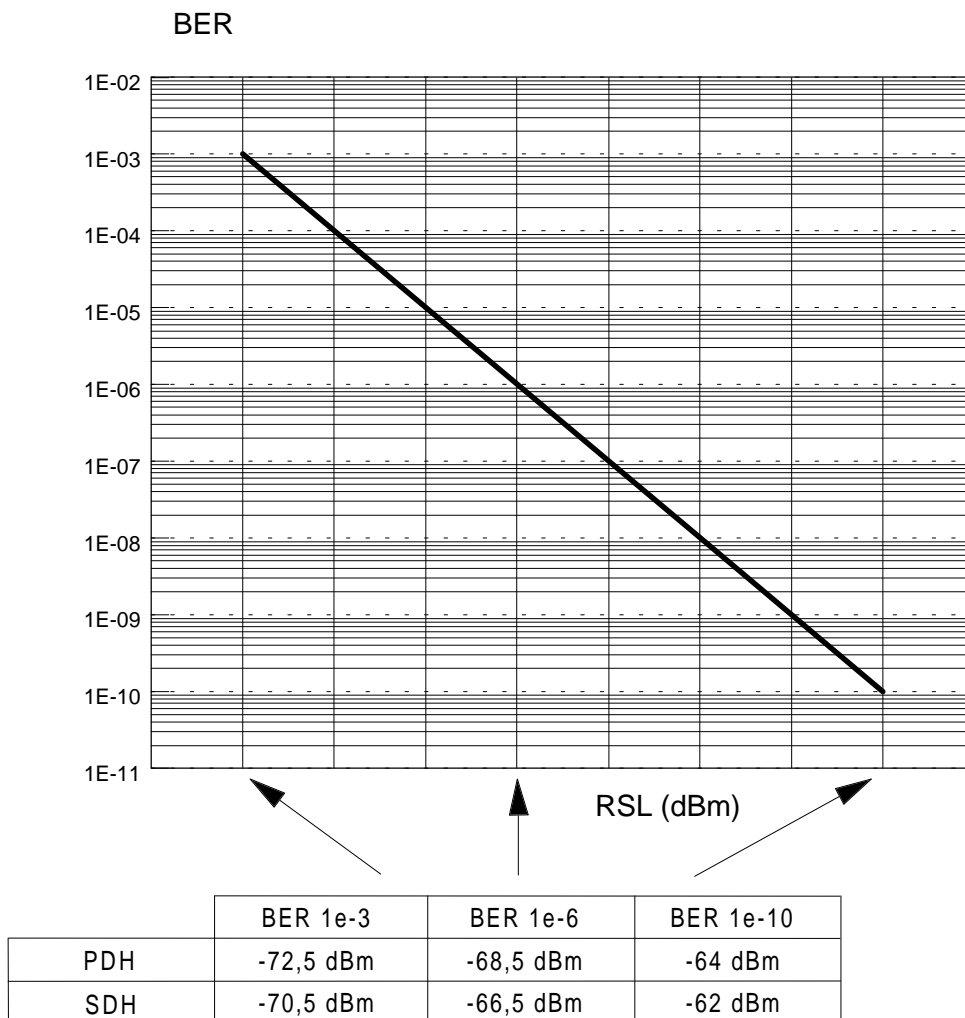

Figure 3: BER versus Receiver Signal Level (RSL) for frequencies < 11 GHz

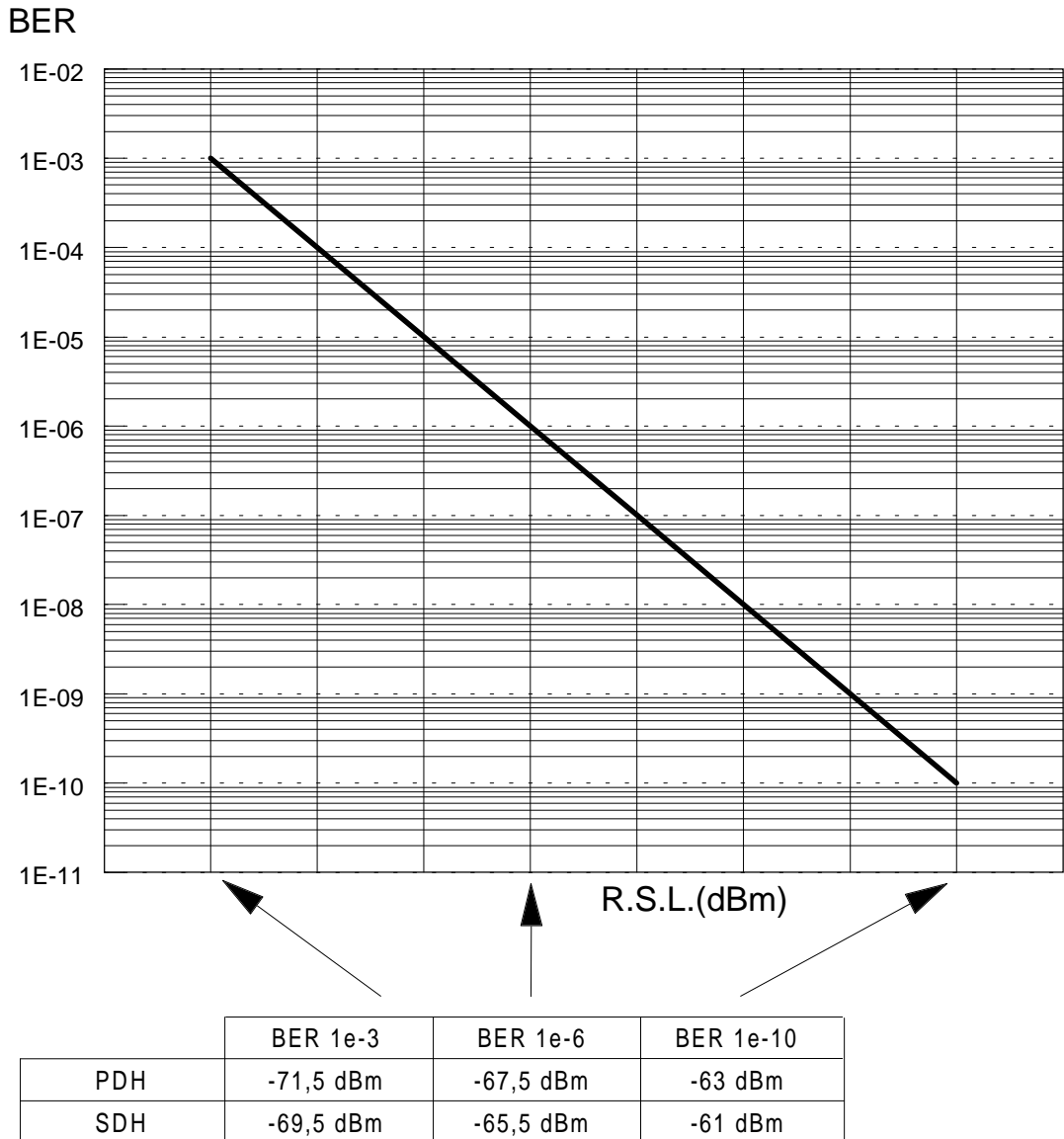

Figure 4: BER versus receiver signal level for frequencies > 11 GHz

5.5.2 Spurious emissions

It is necessary to define spurious emissions from receiver for two reasons:

- to limit interference into systems operating wholly externally to the system;
- to limit local interference within the system where receivers are directly connected via the filter and branching systems.

This leads to two sets of spurious emission limits where the specific limits given for "internal" interference are required to be no greater than the "external" level limits at point B for indoor systems and C for outdoor systems where a common Tx/Rx duplexer is used.

5.5.2.1 Spurious emissions external

According to ITU-R the external spurious emissions are defined as emissions at frequencies which are outside the nominal carrier frequency $\pm 250\%$ of the relevant channel spacing.

The frequency range in which the spurious emissions specifications apply is 30 MHz to 45 GHz. The limit values referred at point C' are:

- 30 MHz to 21,2 GHz: -60 dB in any 100 kHz BW;
- 21,2 GHz to 45 GHz: -30 dBm in any 1 MHz BW.

The measuring bandwidth will be 100 kHz up to 21,2 GHz and 1 MHz above this limit.

For "noise-like" emissions, the limits are intended not to be exceeded in any elementary measuring bandwidth.

5.5.2.2 Spurious emissions-internal

For spurious emissions at the local oscillator frequency, provisional limits of ≤ -110 dBm shall apply (referenced to point B).

5.6 System characteristics without diversity

5.6.1 BER performance

BER versus receive signal power level referred to point C of the system block diagram (figure 1) shall be as given in figure 3 for systems operating below 11 GHz; and as given in figure 4 for systems operating above 11 GHz.

5.6.2 Equipment background BER

The long term BER level under simulated operating conditions without interference is measured with a signal level at point C which is 10 dB above the level which gives $BER = 10^{-6}$ (as specified in figures 3 and 4) and shall be $\leq 10^{-11}$.

5.6.3 Interference sensitivity

All receive signal levels and Signal Interference (S/I) measurements are referred to point C of the system block diagram (see figure 1).

a) Co-channel interference:

The limits of co-channel interference shall be as in table 7, giving maximum Carrier/Interference (C/I) values for 1 dB and 3 dB degradation of the 10^{-6} and 10^{-3} BER limits as given in figures 3 and 4.

Table 7: Co-channel interference sensitivity

co-channel	BER →	10^{-3}		10^{-6}	
	Threshold degradation →	1 dB	3 dB	1 dB	3 dB
Bit rate (MHz)	Channel spacing (MHz)	C/I	C/I	C/I	C/I
2 x 34 2 x 45	0	30	26	34	30
2 x 51	0	33	29	37	33

b) Cross-polar adjacent channel interference:

The limits of adjacent channel interference shall be as given in table 8, giving maximum C/I values for 1 dB and 3 dB degradation of the 10^{-6} and 10^{-3} BER limits as given in figures 3 and 4.

Table 8: Cross-polar adjacent channel interference sensitivity (frequency separation 20 MHz)

Adjacent-channel	BER →	10^{-3}		10^{-6}	
	Threshold degradation →	1 dB	3 dB	1 dB	3 dB
Bit rate (MHz)	Channel spacing (MHz)	C/I	C/I	C/I	C/I
2 x 34 2 x 45	20	5	1	9	5
2 x 51	20	8	4	12	8

c) Co-polar adjacent channel interference:

The limits of adjacent channel interference shall be as given in table 9, giving maximum C/I values for 1 dB and 3 dB degradation of the 10^{-6} and 10^{-3} BER limits as given in figures 3 and 4.

Table 9: Co-polar adjacent channel interference sensitivity (frequency separation 40 MHz)

Adjacent-channel	BER →	10 ⁻³		10 ⁻⁶	
	Threshold degradation →	1 dB	3 dB	1 dB	3 dB
Bit rate (MHz)	Channel spacing (MHz)	C/I	C/I	C/I	C/I
2 x 34 2 x 45	40	-20	-24	-16	-20
2 x 51	40	-17	-21	-13	-17

d) CW spurious interference:

For a receiver operating at the 10⁻⁶ BER threshold given in figures 3 and 4, the introduction of a CW interferer at a level of +30 dB, with respect to the wanted signal and at any frequency up to 40 GHz, excluding frequencies either side of the wanted frequency by up to twice the relevant co-polar channel spacing, shall not result in a BER greater than 10⁻⁵.

NOTE: This test is designed to identify specific frequencies at which the receiver may have a spurious response; e.g. image frequency, harmonics of the receive filter, etc. The actual test range should be adjusted accordingly. The test is not intended to imply a relaxed specification at all out of band frequencies.

5.6.4 Distortion sensitivity

For a delay of 6,3 ns and a BER of 10⁻³, the width of the signature shall not exceed ± 13 MHz relative to the channel assigned frequency and the depth shall not be less than 14 dB.

For a delay of 6,3 ns and a BER of 10⁻⁶, the width of the signature shall not exceed ± 15 MHz relative to the channel assigned frequency and the depth shall not be less than 11 dB.

These limits are valid for both minimum and non-minimum phase cases.

The limits specified for BER = 10⁻³ shall also be verified by the loss-of-synchronization and re-acquisition signatures.

5.7 System characteristics with diversity

Space and frequency diversity techniques are applicable. In this subclause, only combining techniques are considered (for frequency < 11 GHz only).

Rain dominates the outage in bands above 11 GHz and in general, diversity will not be required. However, when diversity is required, baseband switching diversity should be used.

5.7.1 Differential delay compensation

It should be possible to compensate for differential absolute delays due to antennas, feeders and cable connections on the two diversity paths. The limit is at least 100 ns of differential absolute delay.

5.7.2 BER performance

When both receiver inputs (main and diversity, points B and Bd) are fed with same signal level at an arbitrary phase difference, input level limits for specified BER values shall be:

for IF or baseband combining system: 2,5 dB lower than those given under subclause 5.6 for the case without diversity;

for RF combining system: 1,5 dB lower than those given under subclause 5.6 for the case without diversity.

6 Parameters for wideband analogue systems

6.1 Transmit/receive capacity

The video baseband bandwidth used is up to 10 MHz. This may have subcarriers associated with it.

It is recognized that subcarriers will be used to carry three distinct traffic types:

- CW (e.g. continuity pilot);
- low frequency analogue (e.g. audio);
- digital signals.

6.1.1 Applications

- TV of contribution quality;
- TV of distribution quality.

6.2 Baseband parameters

6.2.1 Video Interfaces

Video interfaces should be according to ITU-T Recommendation J.61 [10] where applicable.

6.2.2 Audio interface (if applicable)

Audio interfaces should be according to ITU-T Recommendation J.21 [11] where applicable.

6.2.3 Digital interface (if applicable)

For ITU-T bit rates up to 2 Mbit/s the interface should conform to CCITT Recommendation G.703 [12].

6.2.4 IF interface (if applicable)

Characteristics shall be in accordance with CCIR Recommendation 403-3 [5].

6.2.5 Transmission performance

In view of varied and numerous potential applications for analogue links it is not practical to specify the overall performance characteristics for individual applications.

The absolute performance characteristics for "Broadcast quality" video and audio channels are available in the relevant ITU-T Recommendations.

6.3 Transmitter characteristics

6.3.1 Transmitter power range

Nominal output power at point C' of the system block diagram (figure 1) shall be in the range +20 to +30 dBm.

Regulatory administrations may define sub-ranges within the above nominal range.

6.3.2 Transmitter output power tolerance

The tolerance of the nominal output power shall be within:

- ± 3 dB: class 4.1E (subclause 4.3.1.2)
- ± 2 dB: all other classes (subclauses 4.3.1.1 and 4.3.1.2).

6.3.3 Radiated spectrum

6.3.3.1 Spectrum masks

The radiated spectrum of the composite wideband signal shall fall within the spectrum masks given in figure 5 both for indoor and partially outdoor applications. The spectrum mask does not include frequency tolerance.

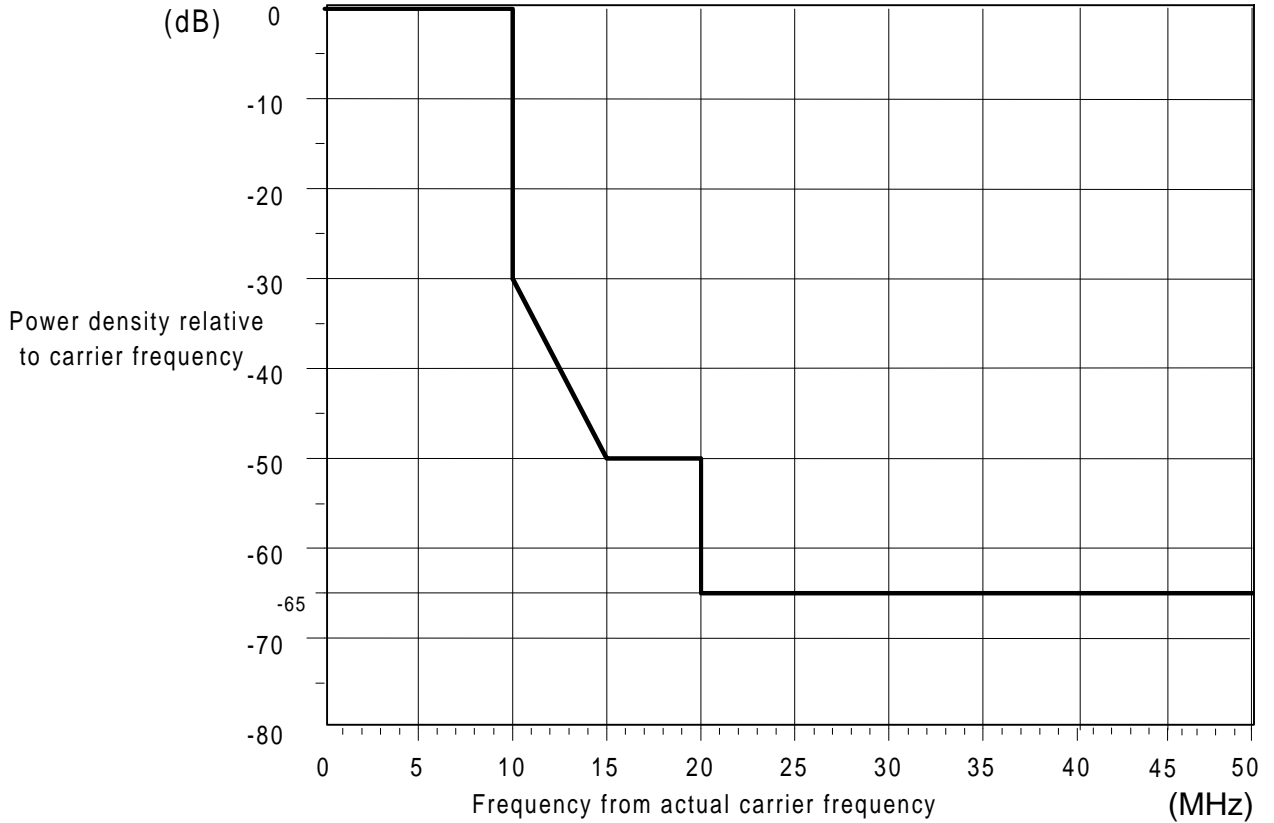

Figure 5: Limits of spectral power density

The 0 dB reference level shown on the spectrum mask shall be set to the level of the unmodulated carrier.

Spectrum analyser settings for RF power spectrum measurements are as shown in table 10.

Table 10: Spectrum analyser settings for RF power spectrum measurement for analogue systems

centre frequency	Transmitter carrier frequency
IF bandwidth	30 kHz
Amplitude scale	Logarithmic, 10 dB/division
Video filter	300 Hz

6.3.3.2 Frequency deviation

- a) Frequency deviation for a TV signal with a baseband reference sinusoidal signal at a frequency corresponding to the emphasis characteristic cross-over frequency (according to CCIR Recommendation 405-1 [6]) shall be 8 MHz peak-to-peak;
- b) frequency deviation for audio subcarriers will be defined by the manufacturers and shall not exceed 2 MHz peak-to-peak for digital subcarrier and 0,9 MHz peak-to-peak for each analogue subcarrier;

- c) frequency deviation for continuity pilot (if applicable) shall be (see CCIR Recommendation 401-2 [4]):
- 140 kHz for 8,5 MHz pilot;
 - 100 kHz for 9,023 MHz pilot.

6.3.4 Spurious emissions

It is necessary to define spurious emissions from transmitters for two reasons:

- a) to limit interference into systems operating wholly externally to the system;
- b) to limit local interference within the system where transmitters and receivers are directly connected via the filter and branching systems.

This leads to two sets of spurious emission limits where the specific limits given for "internal" interference are required to be no greater than the "external" level limits at point C'.

6.3.4.1 Spurious emissions-external

According to ITU-R the external spurious emissions are defined as emissions at frequencies which are outside the nominal carrier frequency $\pm 250\%$ of the relevant channel spacing.

The frequency range in which the spurious emissions specifications apply is 30 MHz to 45 GHz. The limit values referred at point C' are:

- 30 MHz to 21,2 GHz: -60 dBm in any 100 kHz BW;
- 21,2 GHz to 45 GHz: -30 dBm in any 1 MHz BW.

The measuring bandwidth will be 100 kHz up to 21,2 GHz and 1 MHz above this limit.

For "noise-like" emissions, the limits are intended not to be exceeded in any elementary measuring bandwidth.

Within $\pm 250\%$ of the relevant channel spacing the unwanted emission level shall not exceed the limits fixed by the relevant spectrum mask.

6.3.4.2 Spurious emissions-internal

The levels of the spurious emissions from the transmitter, referenced to point B' are specified in table 11.

Table 11: Internal levels for the transmitter spurious emissions

Spurious emission frequency relative to channel assigned frequency	Specification limit	Controlling factor for requirement applicaton
The average level of all spurious signals both discrete CW and noise-like (including $LO \pm IF$ and $LO \pm 2IF$), evaluated as total signal level	≤ -90 dBm	If spurious signal's frequency falls within receiver half band, for digital systems with multi-channel branching networks
	≤ -70 dBm	If spurious signal's frequency falls within receiver half band, for digital systems without branching networks (i.e. with duplexer)
Other spurious evaluated as in subclause 6.3.4.1	≤ -45 dBm	If spurious signal's frequency falls within transmitter half band

6.3.5 Radio frequency tolerance

Radio frequency tolerances are shown in table 12.

Table 12: Frequency stability

	Frequency bands <11 GHz	Frequency bands >11 GHz
Indoor systems	± 40 ppm	± 40 ppm
Outdoor systems	± 80 ppm	± 65 ppm
Direct modulation systems	± 150 ppm	± 130 ppm

6.4 Receiver characteristics

All levels are referenced to point C on block diagram.

6.4.1 Input level range

From -20 dBm to receive threshold as defined in subclause 6.5.1

6.4.2 Spurious emissions

It is necessary to define spurious emissions from receivers for two reasons:

- a) to limit interference into systems operating wholly externally to the system ;
- b) to limit local interference within the system where receivers are directly connected via the filter and branching systems.

This leads to two sets of spurious emission limits where the specific limits given for "internal" interference are required to be no greater than the "external" level limits at point B for indoor systems and C for outdoor systems where a common Tx/Rx duplexer is used.

6.4.2.1 Spurious emissions-external

According to ITU-R the external spurious emissions are defined as emissions at frequencies which are outside the nominal carrier frequency $\pm 250\%$ of the relevant channel spacing.

The frequency range in which the spurious emissions specifications apply is 30 MHz to 45 GHz. The limit values referred at point C' are:

- 30 MHz to 21,2 GHz: -60 dBm in any 100 kHz BW;
- 21,2 GHz to 45 GHz: -30 dBm in any 1 MHz BW.

The measuring bandwidth 100 kHz up to 21,2 GHz and 1 MHz above this limit.

For "noise-like" emissions, the limits are intended not to be exceeded in any elementary measuring bandwidth.

6.4.2.2 Spurious emissions-internal

For spurious emissions at the local oscillator frequency, provisional limits of ≤ -110 dBm shall apply (referenced to point B).

6.4.3 Noise figure

The receiver noise figure shall not exceed 12 dB in case of direct modulation systems and 9 dB for the other systems.

6.5 System performance

6.5.1 Receiver threshold

The receiver threshold is defined as the receive signal level referred to point C of the system diagram (see figure 1), at which a certain minimum performance is reached. The signal/unweighted noise ratio shall be measured at each output port (video, audio, etc.) as a function of RSL. The receiver threshold shall be defined as the receiver level at which the relationship between the receive signal level and the output signal/noise ratio deviates by 3 dB. It is recognized that for a composite video signal (incorporating modulated sub-carriers) the threshold in this case should be taken as the highest receive signal level at which any of the output signals reaches the receiver threshold.

6.5.2 Interference sensitivity

a) Co-channel interference:

It should be recognized that the degradation caused by this interference will depend on a number of equipment characteristics (e.g. deviation, receiver noise performance etc.) and it is therefore not proposed to set limits on this parameter. However it is desirable to measure and record the co-channel interference level.

b) Adjacent Channel Interference:

For a receiver operating with a wanted signal whose level is 9 dB above the receiver threshold measured in subclause 6.5.1, the introduction at point C of a like modulated interferer at the level and frequency separation given in table 13 should not result in a degradation of the output signal/noise ratio of more than 1 dB.

Table 13: Adjacent channel separation and interference levels

Separation of wanted and interfering signal (MHz)		Interference level (carrier/interference (dB))	
Co-polar	Cross-polar	Co-polar	Cross-polar
40	20	0	20

c) CW Spurious Interference:

For a receiver operating with a wanted signal whose level is 9 dB above the receiver threshold measured in subclause 6.5.1, the introduction at point C of a CW interferer at a level of +30 dB with respect to the wanted signal and at any frequency from 30 MHz up to 40 GHz, excluding frequencies either side of the wanted signal by up to twice the relevant co-polar spacing, shall not result in a degradation of any output signal/noise of more than 1 dB.

Annex A (informative): Automatic Transmit Power Control (ATPC)

ATPC can be useful in many circumstances, especially:

- to improve analogue-digital compatibility in the case of antennas with poor cross-polarization discrimination performance or in the case of high nominal output power for the Digital Radio Relay Systems (DRRS);
- to reduce digital to digital distant interference between hops which re-use the same frequency;
- to improve compatibility with both digital and analogue systems at nodal stations;
- to reduce the effects of up-fading propagation conditions on the system.

ATPC is an optional feature which is aimed at driving the Transmit (TX) power amplifier output level from a proper minimum calculated to facilitate the radio network planning. This figure is also used in the case of normal propagation up to a maximum value defined by the relative class of output power and the complete fulfilment of all the specifications defined in this ETS.

The ATPC range is the power interval from the nominal output power level to the lowest power amplifier output level (at point B') with ATPC.

Annex B (informative): Example of a channel plan for 20 MHz alternate channel spacing in the 10 GHz and 14 GHz frequency band

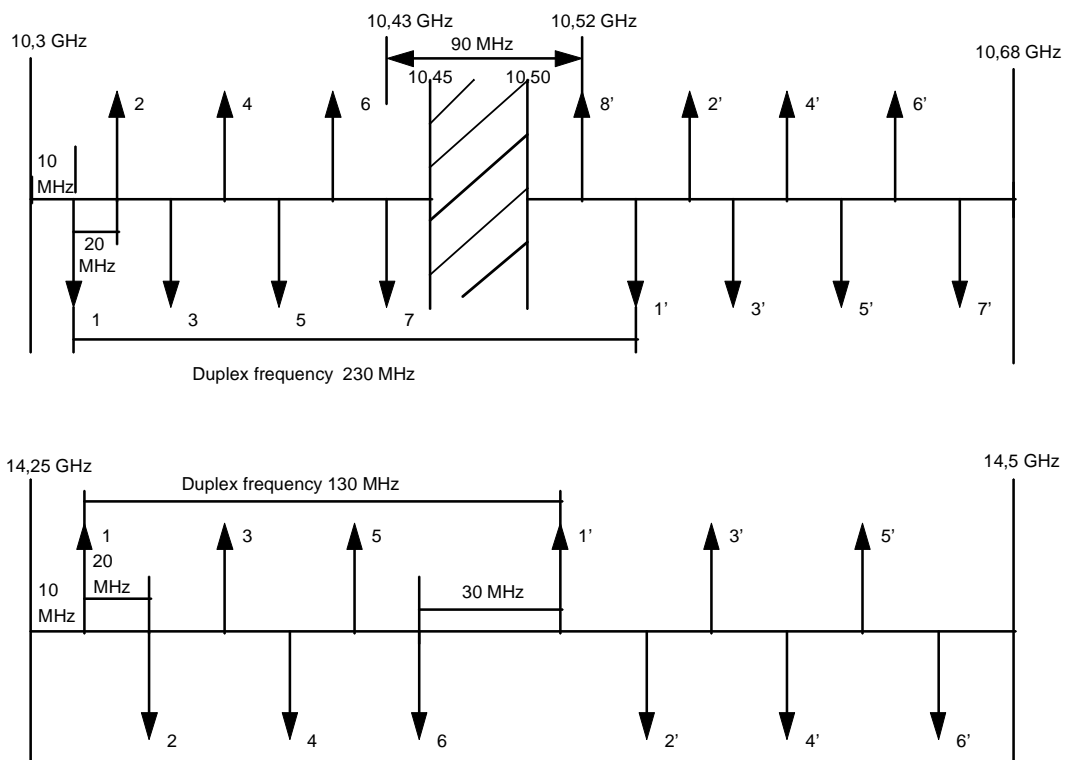

Figure B.1: Channel plan for 20 MHz alternate channel spacing in the 10 GHz and 14 GHz frequency bands used in Italy

History

Document history			
July 1995	Public Enquiry	PE 88:	1995-07-24 to 1995-11-17
August 1996	Vote	V 109:	1996-08-12 to 1996-10-18