



**E**UROPEAN  
**T**ELECOMMUNICATION  
**S**TANDARD

**FINAL DRAFT**

pr **ETS 300 636**

August 1996

---

Source: ETSI TC-TM

Reference: DE/TM-04015

ICS: 33.060.30

**Key words:** TDMA, multipoint, transmission, radio

**Transmission and Multiplexing (TM);  
Time Division Multiple Access (TDMA)  
point-to-multipoint digital radio systems  
in the frequency range 1 to 3 GHz**

**ETSI**

European Telecommunications Standards Institute

**ETSI Secretariat**

**Postal address:** F-06921 Sophia Antipolis CEDEX - FRANCE

**Office address:** 650 Route des Lucioles - Sophia Antipolis - Valbonne - FRANCE

**X.400:** c=fr, a=atlas, p=etsi, s=secretariat - **Internet:** secretariat@etsi.fr

Tel.: +33 92 94 42 00 - Fax: +33 93 65 47 16

---

**Copyright Notification:** No part may be reproduced except as authorized by written permission. The copyright and the foregoing restriction extend to reproduction in all media.

© European Telecommunications Standards Institute 1996. All rights reserved.



## Contents

Foreword .....	5
Introduction.....	5
1 Scope .....	7
1.1 Applications.....	7
1.2 Frequencies .....	7
1.3 Access method .....	7
2 Normative references.....	7
3 Symbols and abbreviations .....	8
3.1 Symbols .....	8
3.2 Abbreviations .....	8
4 General system architecture .....	9
4.1 Sub-system types .....	9
4.2 System characteristics.....	10
4.2.1 System capacity .....	10
4.2.2 Transmission error performance.....	10
4.2.3 Round trip delay .....	10
4.2.4 Transparency .....	10
4.2.5 Telecommunications Management Network (TMN) interface.....	10
5 Radio characteristics.....	10
5.1 Frequency bands .....	10
5.2 Channel arrangement .....	10
5.3 Transmitter characteristics .....	10
5.3.1 TX power range.....	10
5.3.2 Spectrum mask .....	11
5.3.3 Transmitter spurious emissions .....	12
5.3.4 RF tolerance.....	13
5.4 Receiver characteristics.....	13
5.4.1 Input level range .....	13
5.4.2 Spurious emissions .....	13
5.4.3 BER performance.....	13
5.4.4 Interference sensitivity.....	13
5.4.4.1 Adjacent channel rejection .....	13
5.4.4.2 Co-channel rejection.....	14
5.4.5 Image frequency rejection.....	14
5.5 RF equipment port .....	14
5.5.1 RF interface.....	14
5.5.2 Return loss .....	14
6 Types of services / subscriber and exchange interfaces .....	15
7 Power supply and environmental characteristics .....	15
7.1 Power supply.....	15
7.2 Environmental conditions.....	15
7.2.1 Equipment within weather protected locations .....	15
7.2.2 Equipment for non-weather protected locations.....	16
7.3 Electromagnetic compatibility conditions .....	16
7.4 Feeder/Antenna requirements .....	16
History.....	17

Blank page

## Foreword

This final draft European Telecommunication Standard (ETS) has been produced by the Transmission and Multiplexing (TM) Technical Committee of the European Telecommunications Standards Institute (ETSI), and is now submitted for the Voting phase of the ETSI standards approval procedure.

Proposed transposition dates	
Date of latest announcement of this ETS (doa):	3 months after ETSI publication
Date of latest publication of new National Standard or endorsement of this ETS (dop/e):	6 months after doa
Date of withdrawal of any conflicting National Standard (dow):	6 months after doa

## Introduction

The main field of application of Point-to-Multipoint (P-MP) systems is to provide access to both the Public Switched Telephone Network (PSTN) and private networks (Private Digital Network (PDN)), particularly for remote subscribers. By means of P-MP systems the network service area may be extended to cover both distant and scattered subscriber locations.

These remote subscribers, in a similar manner to the city subscriber, are offered the full range of services by the particular public or private network. Subscribers have access to these services by means of the various standardised user network interfaces (2-wire loop, data, ...).

P-MP applications in the metropolitan and urban environment are mainly for the provision of new data services for business subscribers and for the extension of Integrated Services Digital Network (ISDN) services to local subscribers.

The frequency bands below 3 GHz are particularly suitable for the extension of telecommunications services to distant rural and suburban subscribers.

P-MP systems provide standard network interfaces and transparently connect subscribers to the appropriate network node (local switch, ...). These systems allow a service to be connected to a number of subscribers ranging from a few users to several hundred and over a wide range of distances.

P-MP systems are generally, but not necessarily, configured as pre-assigned systems or as Demand Assigned Multiple Access (DAMA) radio systems.

The essential features of a typical P-MP DAMA radio systems are:

- efficient use of the radio spectrum;
- concentration;
- transparency.

Radio is often the ideal way of obtaining communications at low cost and almost independent of distance and difficult topology. Moreover, only a small number of sites are required for these installations, thus facilitating rapid implementation and minimising maintenance requirements of the systems.

Concentration means that N subscribers can share n channels (N being larger than n), allowing better use to be made of the available frequency spectrum and at a lower equipment cost. The term "multi-access" is derived from the fact that every subscriber has access to every channel (instead of a fixed assignment as in most multiplex systems). When a call is initiated one of the available channels is allocated to it. When the call is terminated, the channel is released for another call.

Concentration requires the use of distributed intelligent control which in turn allows many other operation and maintenance functions to be added.

Transparency means that the exchange and the telephone communicate with each other without being aware of the radio link.

## 1 Scope

### 1.1 Applications

The scope of this European Telecommunication Standard (ETS) covers the following Point-to-Multipoint (P-MP) applications:

- voice;
- telex;
- low speed data (up to 64 kbit/s);
- Integrated Services Digital Network (ISDN) (basic rate access).

### 1.2 Frequencies

This ETS covers fixed P-MP services operating in the 1,5 GHz, 2,2 GHz, 2,4 GHz and 2,6 GHz bands and having the frequency plans as given in CEPT Recommendation T/R 13-01 [1] for 1,5 GHz, 2,2 GHz and 2,6 GHz bands. For the 2,4 GHz band, the CCIR Recommendation F.701 [2] is applicable.

### 1.3 Access method

This ETS covers Time Division Multiple Access (TDMA) systems.

## 2 Normative references

This ETS incorporates by dated or undated reference, provisions from other publications. These normative references are cited at the appropriate places in the text and the publications are listed hereafter. For dated references, subsequent amendments to or revisions of any of these publications apply to this ETS only when incorporated in it by amendment or revision. For undated references, the latest edition of the publication referred to applies.

- |      |   |
|------|---|
| [1]  | CEPT T/R 13-01: "Preferred channel arrangements for fixed services in the range 1 to 3 GHz".  |
| [2]  | CCIR Recommendation F.701 (1990): "Radio-frequency channel arrangements for analogue and digital point-to-multipoint radio systems operating in frequency bands in the range 1.427 to 2.690 GHz (1.5, 1.8, 2.0, 2.2, 2.4 and 2.6 GHz)". |
| [3]  | CCITT Recommendation G.821 (1990): "Error performance of an international digital connection forming part of an integrated services digital network".   |
| [4]  | ITU-T Recommendation G.773 (1990): "Protocol suites for Q-interfaces for management of transmission systems".   |
| [5]  | prETS 300 631: "Transmission and Multiplexing (TM); Radio-relay equipment; Antennas for point-to-point and point-to-multipoint radio links in bands 1 to 3 GHz".  |
| [6]  | ITU-T Recommendation G.712 (1993): "Transmission performance characteristics of pulse code modulation".   |
| [7]  | CCITT Recommendation R.20 (1990): "Telegraph modem for subscriber lines".   |
| [8]  | CCITT Recommendation G.703 (1991): "Physical/electrical characteristics of hierarchical digital interfaces".  |
| [9]  | ETS 300 012: "Integrated Services Digital Network (ISDN); Basic user-network interface Layer 1 specification and test principles".  |
| [10] | ETS 300 324 Parts 1 to 5 and Part 7: "Signalling Protocols and Switching (SPS); V interfaces at the digital Local Exchange (LE) V5.1 interface for the support of Access Network (AN)".   |

- [11] ETS 300 347 Parts 1 and 2: "Signalling Protocols and Switching (SPS); V interfaces at the digital Local Exchange (LE) V5.2 interface for the support of Access Network (AN)".
- [12] ETS 300 132 Parts 1 and 2: "Equipment Engineering (EE); Power supply interface at the input to telecommunications equipment".
- [13] ETS 300 019 Part 1 (sub-parts 0 to 7) and Part 2 (sub-parts 0 to 7): "Equipment Engineering (EE); Environmental conditions and environmental tests for telecommunications equipment".
- [14] ETS 300 385: "Radio Equipment and Systems (RES); ElectroMagnetic Compatibility (EMC) standard for digital fixed radio links and ancillary equipment with data rates at around 2 Mbit/s and above".

### 3 Symbols and abbreviations

#### 3.1 Symbols

For the purposes of this ETS the following symbols apply:

dB	decibel
dBm	decibel relative to 1 milliwatt
GHz	GigaHertz
Hz	Hertz
kbit/s	kilobits per second
kHz	kiloHertz
Mbit/s	Megabits per second
MHz	MegaHertz
ms	millisecond

#### 3.2 Abbreviations

For the purposes of this ETS the following abbreviations apply:

BER	Bit Error Rate
CCS	Central Controller Station
CRS	Central Radio Station
CS	Central Station
DAMA	Demand Assigned Multiple Access
EMC	Electromagnetic Compatibility
ISDN	Integrated Services Digital Network
PDN	Private Digital Network
P-MP	Point-to-Multipoint
PRBS	Pseudo-Random Binary Sequence
PSTN	Public Switched Telephone Network
RS	Repeater Station
TDMA	Time Division Multiple Access
TMN	Telecommunications Management Network
TS	Terminal Station



## 4 General system architecture

A system could consist of physical sub-systems as follows (see figure 1):

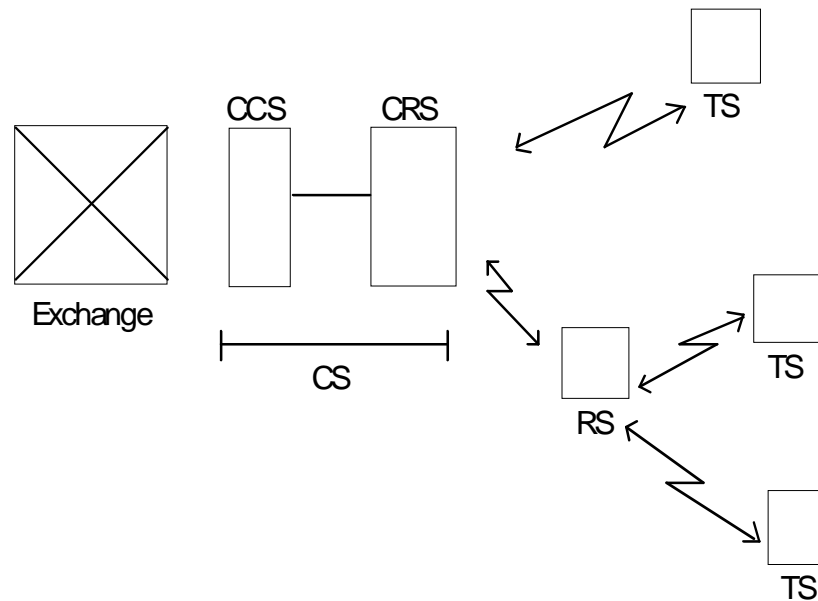

NOTE: Abbreviations used in figure 1 are described in subclause 4.1.

**Figure 1: General system architecture**

### 4.1 Sub-system types

**CS:** Central Station which can be subdivided into two units:

- the exchange unit, also called Central Controller Station (CCS) - (interface to the local switch); and
- the radio unit, also called Central Radio Station (CRS) - (central baseband / radio transceiver).

**TS:** Terminal station (outstations with subscriber interfaces).

**RS:** Repeater Station (radio repeater outstations with or without subscriber interfaces).

The central station performs the interconnection with the local switching exchange, carrying out a concentration function by sharing the total number of available channels in the system. The central station is linked to all remote stations (Repeater Stations (RS) or Terminal Stations (TS)) by microwave transmission paths.

Whenever an existing digital transmission link is available, the network implementation can be optimised by separating the CCS installed at the exchange site and the CRS.

Terminal stations are situated as close as possible to the "centre of gravity" of the subscriber locations. They interface directly with the subscriber loops.

The general characteristics which are typical for P-MP systems are considered in this ETS. These characteristics have been categorised under four headings:

- system;
- radio;
- type of services / subscriber and exchange interfaces;
- power supply and environmental characteristics.

## 4.2 System characteristics

### 4.2.1 System capacity

The system traffic carrying capacity shall be  $n \times 2$  Mbit/s ( $n = 1, 2$  or  $4$ ).

### 4.2.2 Transmission error performance

Transmission performance shall comply with CCITT Recommendation G.821 [3].

### 4.2.3 Round trip delay

The round trip delay (including transmission delay) shall not exceed 20 ms for a voice encoded 64 kbit/s time slot.

### 4.2.4 Transparency

The system shall be fully transparent: the exchange and the telephone subscriber communicate with each other without being aware of the radio link.

### 4.2.5 Telecommunications Management Network (TMN) interface

The TMN interface, if any, should be in accordance with ITU-T Recommendation G.773 [4].

## 5 Radio characteristics

### 5.1 Frequency bands

Five frequency plans are used for digital P-MP systems. Two in the 1,5 GHz band, one each in the 2,2 GHz, 2,4 GHz and the 2,6 GHz band.

### 5.2 Channel arrangement

Table 1: Frequency bands

frequency band	band limits	Transmit/receive spacing
1,5 GHz (I)	1 350 - 1 375 and 1 492 - 1 517 MHz	142 MHz
1,5 GHz (II)	1 375 - 1 400 and 1 427 - 1 452 MHz	52 MHz
2,2 GHz	2 025 - 2 110 and 2 200 - 2 290 MHz	175 MHz
2,4 GHz	2 300 - 2 500 MHz	94 MHz
2,6 GHz	2 520 - 2 670 MHz	74 MHz

Table 2: Channel spacing

Minimum bit rate (Mbit/s)	2	4	8
Channel spacing (MHz)	1,75/2	3,5/4	3,5/4

### 5.3 Transmitter characteristics

#### 5.3.1 TX power range

The maximum value of output power, referred to point C' shall not exceed 35 dBm.

If for proper operation of the system or for regulatory purposes, a reduced range of output power is required, then an internal or external means of adjustment shall be provided.

The tolerance value around the nominal or selected value of output power is  $\pm 1$  dBm.

The transmitted output power means the value measured where the output is connected to a dummy load i.e. power meter or spectrum analyser. The transmitter shall be modulated with a Pseudo Random Binary Sequence (PRBS) test signal.

Two different measurement methods can be used:

- spectrum analyser with resolution Bandwidth (BW) and video BW greater than 1 MHz;
- power meter.

NOTE: Use of a peak power meter is suitable when measuring the output power of transmitters operating in a burst mode.

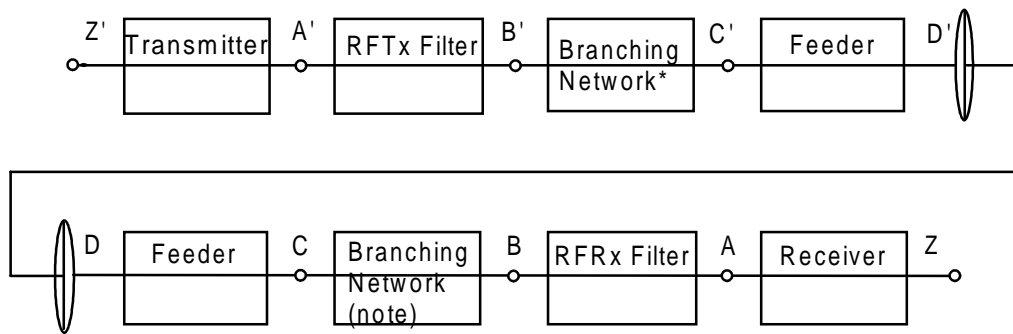

NOTE: Points B & C and B' and C' will coincide if branching networks are not used.

**Figure 2: Radio Frequency (RF) block diagram**

### 5.3.2 Spectrum mask

Spectrum masks are given in figure 3.

The transmitted output power spectrum is defined as: The spectrum when modulated with a test data signal that simulates a fully loaded system, i.e. "all trunks busy" or "continuous mode", e.g. PRBS.

The spectrum measurement at point C' of the system block diagram shall be performed with the "maximum hold" function selected on the spectrum analyser.

The reference level of the output spectrum means that the 0 dB level is the top of the modulated spectrum, disregarding the residual carrier.

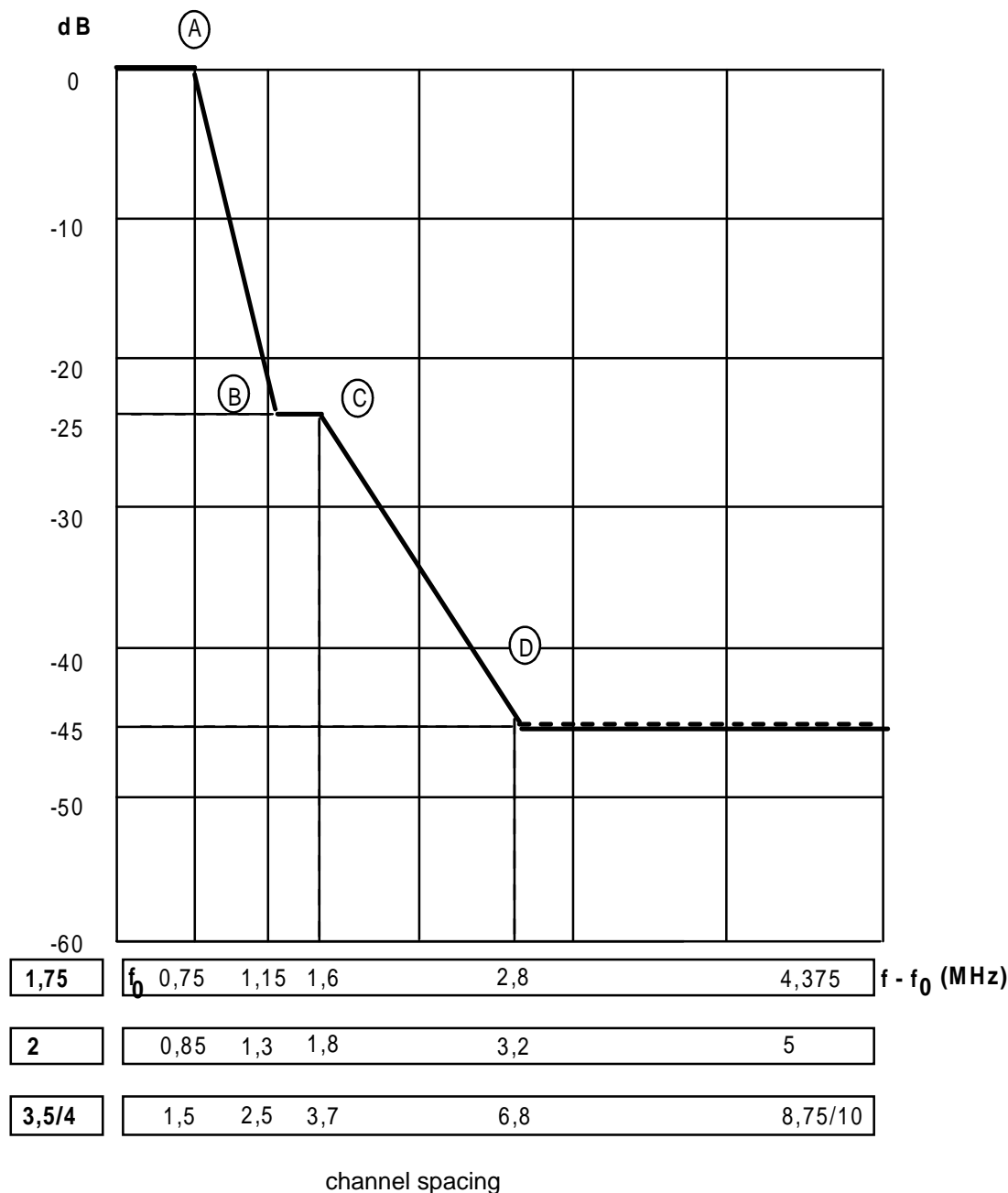

Figure 3: Power spectrum mask ( $f_0$  = nominal carrier frequency)

Table 3: Spectrum analyser settings

Resolution BW	Video BW	Sweep time	Sweep width
30 kHz	300 Hz	10 s	10 MHz

### 5.3.3 Transmitter spurious emissions

For the purposes of this ETS spurious emissions are defined as emissions at frequencies which are outside the nominal carrier frequency  $\pm 2,5$  times the relevant channel spacing.

The frequency range in which the spurious emission specification is to apply is 30 MHz to 10 GHz. The values measured at point C' shall be  $\leq -60$  dBm.

NOTE: The value of -60 dBm may be considered provisional. A decision from CEPT is pending on this issue.

For the purposes of this ETS the measuring bandwidth is in the range 100 kHz to 120 kHz.

Within the exclusion bandwidth defined above, the unwanted emission level shall not exceed the limits fixed by the relevant spectrum mask.

#### 5.3.4 RF tolerance

The maximum radio frequency tolerance shall be  $\pm 15$  ppm for short term factors (environmental effects and turning accuracy). Long term frequency draft due to ageing shall be declared by the manufacturer during the type test.

### 5.4 Receiver characteristics

#### 5.4.1 Input level range

The dynamic range of the receiver for a Bit Error Rate (BER)  $< 10^{-3}$  shall extend for a minimum of 55 dB above the lower threshold for BER= $10^{-3}$  referenced to point C.

#### 5.4.2 Spurious emissions

For the purposes of this ETS spurious emissions are defined as emissions at frequencies which are outside the nominal carrier frequency  $\pm 2,5$  times the relevant channel spacing.

The frequency range in which the spurious emission specification is to apply is 30 MHz to 10 GHz. The values measured at point C' shall be  $\leq -60$  dBm.

NOTE: The value of -60 dBm may be considered provisional. A decision from CEPT is pending on this issue.

For the purposes of this ETS the measuring bandwidth is in the range 100 kHz to 120 kHz.

Within the exclusion bandwidth defined above the unwanted emission level shall not exceed the limits fixed by the relevant spectrum mask.

#### 5.4.3 BER performance

BER versus receive signal power level, referred to point C of the system block diagram (figure 2) shall be equal to or better than the values in table 4:

**Table 4: BER versus receiver signal level**

Bit rate (Mbit/s)	BER $10^{-3}$ (dBm)	BER $10^{-6}$ (dBm)
2	-92	-88
4	-89	-85
8	-83	-79

#### 5.4.4 Interference sensitivity

##### 5.4.4.1 Adjacent channel rejection

Adjacent channel rejection is defined as the ability of the receiver to receive a wanted signal in the presence of a like unwanted signal which is one channel away.

The two signals shall be connected to the receiver input via a combiner, so that the impedance is matched to the nominal impedance.

The wanted signal shall be tuned to the receiver's nominal frequency and be modulated with a PRBS signal. The interfering signal shall be turned off while the wanted signal is adjusted to the level corresponding to BER =  $10^{-6}$  as specified in table 4.

The interfering signal shall be tuned one channel away from the wanted signal and be modulated with a PRBS signal which is un-correlated to the wanted signal.

The interfering signal shall be adjusted to the same level as the wanted signal. The BER shall not be greater than  $10^{-5}$ .

Measurement on both sides of the nominal frequency shall be carried out.

#### **5.4.4.2 Co-channel rejection**

Co-channel rejection is defined as the ability of the receiver to receive a wanted signal in the presence of a like unwanted signal on the same frequency.

The two signals shall be connected to the receiver input via a combiner, so that the impedance is matched to the nominal impedance of the system.

The wanted signal shall be tuned to the receiver's nominal frequency and modulated with a PRBS signal.

The interfering signal shall be turned off while the wanted signal is adjusted to the level corresponding to  $BER = 10^{-6}$  as specified in table 4.

The interfering signal shall be tuned to the same frequency as the wanted signal and modulated with a PRBS signal which is un-correlated to the wanted signal.

The interfering signal shall then be injected at a level which is 23 dB below the wanted signal.

The BER shall not be greater than  $10^{-5}$ .

#### **5.4.5 Image frequency rejection**

If applicable image frequency rejection shall be greater than 75 dB.

### **5.5 RF equipment port**

#### **5.5.1 RF interface**

The RF interface at reference points C and C' of the system block diagram (figure 2) shall be coaxial 50 ohms.

#### **5.5.2 Return loss**

The return loss at reference points C and C' of the system block diagram (figure 2) shall be more than 15 dB at the reference impedance.

## 6 Types of services / subscriber and exchange interfaces

Table 5 lists a range of interfaces for various voice and data services. At least one of these interfaces shall be implemented in a point-to-multipoint system covered by this ETS.

**Table 5: Types of interfaces/ranges**

Type of service	Interface Standards
<b>Subscriber Interfaces</b>	
Analogue (2 wires)	ITU-T Recommendation G.712 [6]
Analogue (4 W + E & M)	ITU-T Recommendation G.712 [6]
Telex	CCITT Recommendation R.20 [7]
Digital data port	CCITT Recommendation G.703 [8]
ISDN basic rate	ETS 300 012 [9]
<b>Network Interfaces</b>	
2 Mbit/s	CCITT Recommendation G.703 [8]
Analogue (2 wires)	ITU-T Recommendation G.712 [6]
Analogue (4 W + E & M)	ITU-T Recommendation G.712 [6]
Telex	ITU-T Recommendation R.20 [7]
Digital data port	CCITT Recommendation G.703 [8]
ISDN basic rate	ETS 300 012 [9]
ISDN + Analogue subscribers + Leased lines 2 Mbit/s Interface	V5.1/V5.2 (ETS 300 324 [10] / ETS 300 347 [11])

Systems shall include methods enabling internal and external synchronisation. The free running clock frequency shall not deviate more than 50 ppm from the nominal value. Moreover it shall be possible to synchronise the clock with an incoming timing signal that deviates 50 ppm from the nominal value (reference can be made to CCITT Recommendation G.703 [8]).

## 7 Power supply and environmental characteristics

### 7.1 Power supply

The equipment shall operate from one or more of the power supplies within the ranges specified in tables 6 and 7 in compliance with ETS 300 132 [12].

**Table 6: Power supplies - direct current**

For 12 V DC nominal:	+10,8 to +13,6 V
For 24 V DC nominal:	-21,8 to -28,1 V
For 48 V DC nominal:	-40,5 to -57,0 V
For 60 V DC nominal:	-50,0 to -72,0 V

**Table 7: Power supplies - alternative current**

For 110 V AC nominal:	99 to 121 V	60 Hz ± 2 Hz
For 230 V AC nominal:	207 to 253 V	50 Hz ± 2 Hz

### 7.2 Environmental conditions

The equipment shall meet the environmental conditions set out in ETS 300 019 [13] which defines weather protected and non weather protected locations classes and test severities.

#### 7.2.1 Equipment within weather protected locations

Equipment intended for operation in temperature controlled locations or partially temperature controlled locations shall meet the requirements of ETS 300 019 [13] classes 3.1 and 3.2 respectively.

Alternatively, the more stringent requirements of ETS 300 019 [13] classes 3.3 (non temperature controlled locations), 3.4 (sites with heat trap) and 3.5 (sheltered locations) may be specified.

### **7.2.2 Equipment for non-weather protected locations**

Equipment intended for operation within non weather protected locations shall meet the requirements of ETS 300 019 [13], class 4.1 or 4.1E.

Class 4.1 applies to many European countries while class 4.1E applies to all European countries.

Weather protected equipment conforming to class 3.3, 3.4, and 3.5 together with an enclosure or cabinet may fulfil the requirements for operating in a non weather protected environment but this is outside the scope of this ETS.

### **7.3 Electromagnetic compatibility conditions**

Equipment shall meet the requirements of the EMC standard : ETS 300 385 [14].

This subject is also under study in ETSI TM4, RES 9 and in the CEPT.

### **7.4 Feeder/Antenna requirements**

The parameters and values are specified in ETS 300 631 [5] which is currently under study in STC TM4.



## History

Document history			
July 1995	Public Enquiry	PE 88:	1995-07-24 to 1995-11-17
August 1996	Vote	V 108:	1996-08-05 to 1996-09-27