



**E**UROPEAN  
**T**ELECOMMUNICATION  
**S**TANDARD

**DRAFT**

pr **ETS 300 635**

July 1995

---

Source: ETSI TC-TM

Reference: DE/TM-04028

ICS: 33.080

**Key words:** SDH, radio specific

**Transmission and Multiplexing (TM);  
Synchronous Digital Hierarchy (SDH)  
radio specific functional blocks**

**ETSI**

European Telecommunications Standards Institute

**ETSI Secretariat**

**Postal address:** F-06921 Sophia Antipolis CEDEX - FRANCE

**Office address:** 650 Route des Lucioles - Sophia Antipolis - Valbonne - FRANCE

**X.400:** c=fr, a=atlas, p=etsi, s=secretariat - **Internet:** secretariat@etsi.fr

Tel.: +33 92 94 42 00 - Fax: +33 93 65 47 16

---

**Copyright Notification:** No part may be reproduced except as authorized by written permission. The copyright and the foregoing restriction extend to reproduction in all media.

© European Telecommunications Standards Institute . All rights reserved.



## Contents

Foreword .....	5
1 Scope .....	7
2 Normative references .....	7
3 Abbreviations and symbols .....	8
3.1 Abbreviations .....	8
4 Generalised functional block diagram .....	9
4.1 SDH Radio Synchronous Physical Interface function (RSPI) .....	10
4.1.1 Signal flow from B to R .....	12
4.1.2 Signal flow from R to B .....	12
4.1.3 Application to the transmission of N times STM-N .....	13
4.2 Radio OverHead Access (ROHA) .....	13
4.3 Radio Protection Switch (RPS) .....	14
4.3.1 Signal flow .....	16
4.3.2 Additional requirement on the signal flow from XT (tributary side) to XL (line side) .....	17
4.3.3 Additional requirement on the signal flow from XL (line side) to XT (tributary side) .....	17
4.3.4 Switching initiation criteria .....	18
4.3.4.1 Lockout .....	18
4.3.4.2 Forced switch .....	18
4.3.4.3 Autoswitch signal fail .....	18
4.3.4.4 Autoswitch HBER and LBER .....	18
4.3.4.5 Autoswitch EW .....	19
4.3.4.6 Manual Switch .....	19
4.3.4.7 Exercise .....	19
4.3.5 Switching time .....	19
4.3.6 Switch restore .....	19
4.3.6.1 Forced restore .....	19
4.3.6.2 Automatic forced restore .....	19
4.3.6.3 Automatic switch restore .....	19
5 Requirement of operation and maintenance .....	20
5.1 RSPI requirements .....	20
5.2 RPS requirements .....	22
5.3 ROHA requirements: .....	22
6 Performance monitoring .....	23
Annex A (informative): RPS practical implementations .....	24
A.1 Signal flow and main functionality .....	26
A.1.1 RPS type A .....	26
A.1.2 RPS type B .....	27
A.1.3 RPS type C .....	27
A.1.4 RPS type D .....	27
Annex B (informative): Example of ROHA SOH managing of 2 Mbit/s wayside traffic in the regenerator sections .....	28
Annex C (informative): Description of the transport network architecture based on SDH DRRS .....	29
C.1 Basic concepts .....	29

C.2	Radio specific atomic functions .....	31
C.2.1	RSPI related atomic functions.....	31
C.2.2	RPS related atomic functions.....	32
Annex D (informative):	Bibliography .....	34
History .....		35

## Foreword

This draft European Telecommunication Standard (ETS) has been prepared by the Transmission and Multiplexing (TM) Technical Committee of the European Telecommunications Standards Institute (ETSI) and is now submitted for the Public Enquiry phase of the ETSI standards approval procedure.

<b>Proposed transposition dates</b>	
Date of latest announcement of this ETS (doa):	3 months after ETSI publication
Date of latest publication of new National Standard or endorsement of this ETS (dop/e):	6 months after doa
Date of withdrawal of any conflicting National Standard (dow):	6 months after doa

Blank page

## 1 Scope

This European Telecommunication Standard (ETS) defines functional blocks specific to the Digital Radio Relay System (DRRS) which uses the Synchronous Digital Hierarchy (SDH) for transmitting n-times the Synchronous Transport Module n (STM-N) signal.

Considering that:

- ITU-T Recommendation G.783 [7] describes the characteristics of SDH equipment functional blocks,

and that

- ETS 300 417 [1] defines a library of basic building blocks and a set of rules, by which they may be combined to describe an SDH digital transmission equipment,

this ETS uses the methodology specified in ITU-T Recommendation G.783 [7], in order to give a generic description of a SDH DRRS.

This ETS defines:

- the functional blocks specific to SDH DRRS.

This ETS does not define:

- the information model for Radio Relay Network Elements;
- the protocol stack to be used for message communication;
- the network level management processes;
- the functional block already defined by ITU-T Recommendation G.783 [7];
- the radio specific management of performance monitoring requirements.

The equipment functionality is consistent with SDH multiplexing structure given in ETS 300 147 [15].

Equipment developed prior to this ETS may not comply in all details with this ETS.

## 2 Normative references

This ETS incorporates, by dated or undated reference, provisions from other publications. These normative references are cited at the appropriate places in the text and the publications are listed hereafter. For dated references, subsequent amendments to or revisions of any of these publications apply to this ETS only when incorporated in it by amendment or revision. For undated references, the latest edition of the publication referred to applies.

- [1] prETS 300 417 (1994): "Transmission and Multiplexing (TM); Generic functional requirements for Synchronous Digital Hierarchy (SDH) transmission equipment" (DE/TM-01015).
- [2] ETS 300 304 (1994): "Synchronous Digital Hierarchy (SDH) information model for the network element (NE) view".
- [3] ITU-R Recommendation 750: "Architectures and functional aspects of radio-relay systems for SDH based networks".
- [4] ITU-T Recommendation G.773: "Protocols suites for Q Interfaces for management of transmission systems".
- [5] ITU-T Recommendation G.781: "Structure of Recommendations on equipment for the synchronous digital hierarchy (SDH)".
- [6] ITU-T Recommendation G.782: "Types and general characteristics of synchronous digital hierarchy (SDH) equipment".

- [7] ITU-T Recommendation G.783: "Characteristics of synchronous digital hierarchy (SDH) multiplexing equipment functional blocks".
- [8] ITU-T Recommendation G.784: "Synchronous digital hierarchy (SDH) management".
- [9] ITU-T Recommendation G.803: "Architectures of transport networks based on the synchronous digital hierarchy (SDH)".
- [10] ITU-T Recommendation G.831: "Management capabilities of transport networks based on the synchronous digital hierarchy (SDH)".
- [11] ITU-T Recommendation M.3010: "Principles for a telecommunications management network".
- [12] ITU-T Recommendation M.60: "Maintenance Terminology and definitions".
- [13] ITU-T Recommendation Q.811: "Lower layer Protocol profiles for the Q3 interface".
- [14] ITU-T Recommendation Q.812: "Upper layer Protocols profile for the Q3 interface".
- [15] ETS 300 147 (1994): "Transmission and Multiplexing (TM); Synchronous Digital Hierarchy (SDH) Multiplexing structure".
- [16] ITU-T Recommendation G.707: "Synchronous digital hierarchy bit rates".
- [17] ITU-T Recommendation G.708: "Network node interface for the synchronous digital hierarchy".
- [18] ITU-T Recommendation G.709: "Synchronous multiplexing structure".

### 3 Abbreviations and symbols

#### 3.1 Abbreviations

For the purpose of this ETS, the following abbreviations apply:

AIS	Alarm Indication Signal
AP	Access Point
ATPC	Automatic Transmit Power Control
BER	Bit Error Rate
CMIP	Common Management Information Protocol
CMIS	Common Management Information Service
CP	Connection Point
CTP	Connection Termination Point
DRRS	Digital Radio Relay System
EW	Early Warning
GTP	Group Termination Point
HPA	Higher Order Path Adaptation
IF	Intermediate Frequency: frequency(s) other than RF used for the purpose of implementation depending functions (e.g. easier filtering).
IA	Indirect Adapter
IOS	Intra-Office Section
LOF	Loss Of Frame
LPA	Lower Order Path Adaptation
MOC	Managed Object Class
MSP	Multiplex Section Protection
MSOH	Multiplex Section OverHead
NE	Network Element
OS	Operation System



OSI	Open System Interconnection
PDH	Plesiochronous Digital Hierarchy
Pkg	Packages
PI	Physical Interface
RF	Radio Frequency
RFCOH	Radio Frame Complementary OverHead
ROHA	Radio OverHead Access
RPI	Radio (generic) Physical Interface
RPPI	Radio Plesiochronous Physical Interface
RSPI	Radio Synchronous Physical Interface
RPS	Radio Protection Switching
RDN	Relative Distinguished Name
RRR	Radio Relay Regenerator
RRT	Radio Relay Terminal
RS	Regenerator Section
RSOH	Regenerator Section OverHead
RST	Regenerator Section Termination
SDH	Synchronous Digital Hierarchy
SEMF	Synchronous Equipment Management Function
SETS	Synchronous Equipment Timing Source
SF	Switch Failure
Snk	Sink
SOH	Section OverHead
SPI	SDH Physical Interface
Src	Source
STM-N	Synchronous Transport Module n
STM-RR	Synchronous Transport Module for Sub-STM-1 Radio Relay
TMN	Telecommunication Management Network
TP	Termination Point
TTP	Trail Termination Point
VC-n	Virtual Container n
XPIC	Cross Polar Interference Canceller

#### 4 Generalised functional block diagram

Figure 1 is taken as a generalised block diagram for STM-N systems (in this figure Ux, Kx and Sx interface numbering for radio specific blocks has been taken starting from 50 onward).

In figure 1 only the most common ITU-T Recommendation G.783 [7] defined functional blocks are reported, together with the radio specific ones. Nevertheless other present or future defined functional blocks may be implemented, if applicable, into SDH DRRS.

Additional description using ITU-T Recommendation G.803 [9] and ETS 300 417 [1] methodology is not in the scope of this ETS, however some basic related concept may be found in annex B.

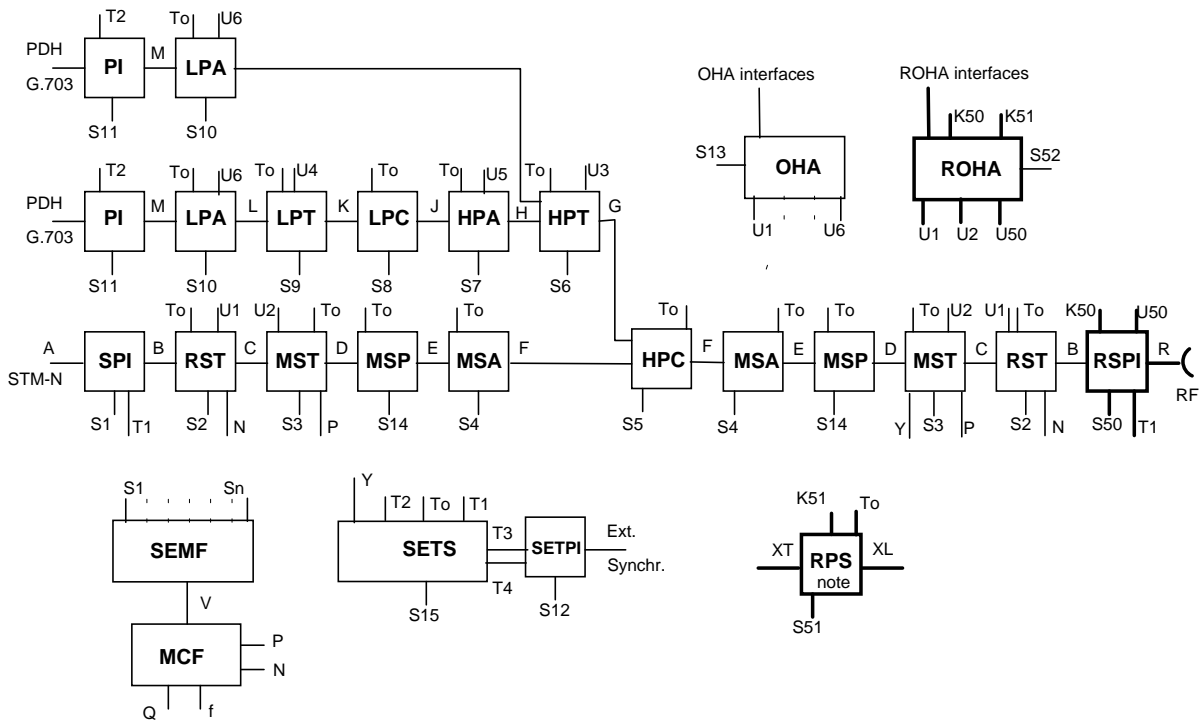

- U50: Reference point for Radio Frame Complementary OverHead (RFCOH) bytes access (insertion/extraction);
- K50: Media specific or RFCOH bytes (whichever is applicable) interface for Radio Synchronous Physical Interface (RSPI) usage;
- K51: Media specific or RFCOH bytes (whichever is applicable) interface for Radio Protection Switching (RPS) usage;
- XT: RPS Reference point (Tributary side);
- XL: RPS Reference point (Line side);
- Other references: see ITU-T Recommendations G.782 [6] and G.783 [7].

NOTE: The RPS functional block comprises a connection type function which, for an implementation dependent purpose, can be inserted in between any other functional block to perform specific (n+m) line protection for the radio section. It has the same "X" input/output interfaces which are always compatible with any interface where it may be inserted, namely reference points B, C, D, E or F (see informative annex D for details).

Figure 1: Generalised SDH-DRRS logical and functional block diagram

#### 4.1 SDH Radio Synchronous Physical Interface function (RSPI)

The RSPI function provides the interface between the radio physical medium at reference point R and the Regenerator Section Termination (RST) function at reference point B.

DATA at R is a Radio Frequency (RF) signal containing an STM-M signal with non-standardised use of Section Overhead (SOH) media dependent bytes and (if used) an additional arbitrary RFCOH. Therefore, in accordance with ITU-R Recommendation 750 [3], mid air interconnectivity between transmitter and receiver of different vendors is not required.

The information flows associated with the RSPI function are described with reference to figure 2. This functional block is, therefore, expanded in figure 3.

K50 is an interface for any radio specific control and monitoring use (e. g. Automatic Transmit Power Control (ATPC)) making use of the media specific bytes of Regenerator Section OverHead (RSOH) or of RFCOH extracted through reference points U1 or U50 respectively and made available by the Radio OverHead Access (ROHA) functional block.

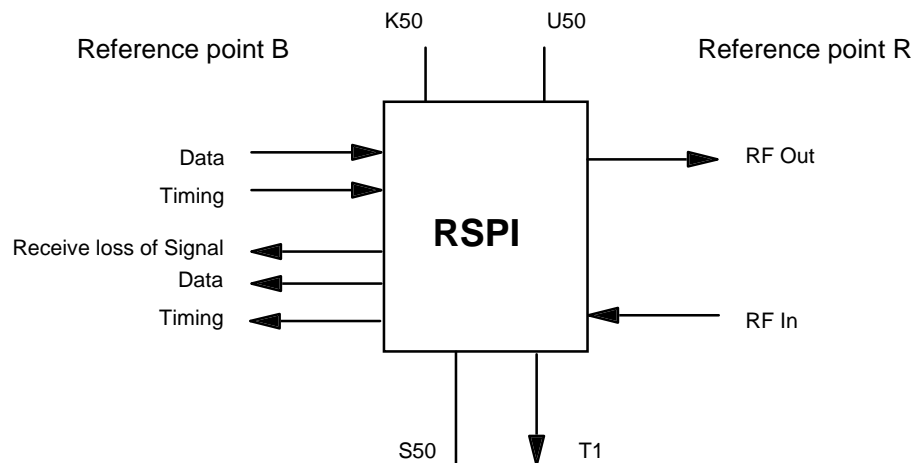

**Figure 2: RSPI functional block**

The RSPI functions are subdivided into transmit and receive functions; a second level of decomposition refinement is the splitting of the transmit and receive functions into two smaller sub blocks, as shown in figure 3. These are:

- Transmit Function: Modulation Function;  
TX Function;
- Receive Function: Demodulation Function;  
RX Function.

These functions are described as follows:

- The Modulation function performs all the processing needed to transfer the STM-M data signal at reference point B into a suitable Intermediate Frequency (IF) or RF signal (whichever is applicable), including scrambling and optionally, channel-coding and RFCOH insertion.
- The TX function represents the process of power amplifying the signal, coming from the modulation function, filtering and optionally, up converting from the modulation function for presentation at reference point R.
- The RX function represents any signal processing between the receiver input at reference point R, and the demodulation function input. The signal processing performed by the RX-function also includes any diversity of reception arrangement, which would be represented as an equipment redundancy by multiple receivers (and if required demodulators) within a single receive function.
- The Demodulation function represents any process (including propagation countermeasures e.g. equaliser and Cross Polar Interference Canceller (XPIC)) of converting an IF or RF signal (whichever is applicable), into a fully formatted STM-M data signal for presentation at reference point B. The demodulation process includes the functions of filtering, timing recovery and descrambling, and may optionally include RFCOH extraction and propagation countermeasures, e.g. equaliser, XPIC, error correction.

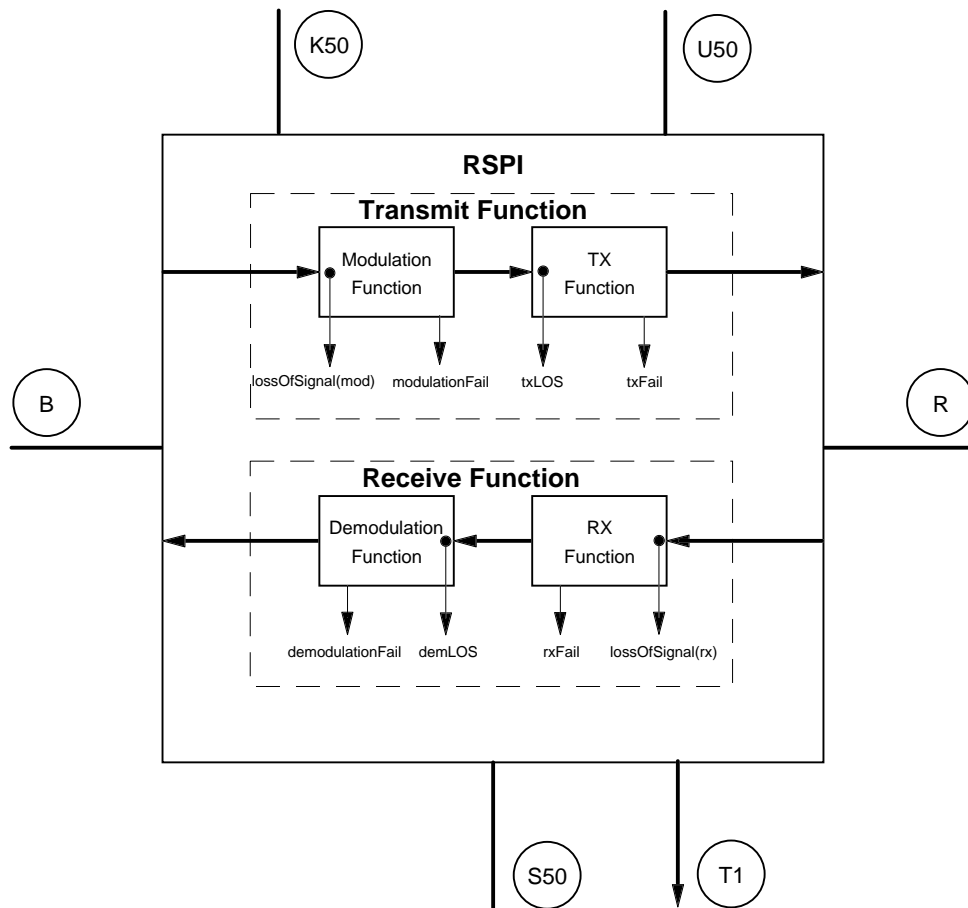

**Figure 3: RSPI functional block(detail)**

Given that the RSPI includes modulation and demodulation functions, it performs a regeneration of the signal in the DRRS repeater. As a consequence, the RSPI function in SDH DRRS shall be always used in conjunction with a RST function in order to perform SDH functionalities.

**4.1.1 Signal flow from B to R**

Data flow at B is the fully formatted STM-M data as specified in ITU-T Recommendations G.707 [16], G.708 [17] and G.709 [18]. Data is presented together with associated timing at B by the RST function. The RSPI function multiplexes these data together with the RFCOH (if used) and adapts them for transmission over the RF medium (by means of a suitable modulation format, carrier frequency and output power) and presents it at R.

DATA for inclusion in RFCOH (if used) are inserted at reference point U50.

Radio specific managing data (e.g. ATPC increase/decrease power request from the far end receiver function to control the local transmitter function) will be shown at K50 from functional block ROHA, which has provided proper extraction from the media specific byte of RSOH or from RFCOH through reference point U1 or U50 respectively (see ROHA functional block description).

Indications related to the physical status of the interface shall be reported at S50 to the Synchronous Equipment Management Function (SEMF) functional block.

Requirements of Operation and Maintenance are described in the relevant section of this ETS.

**4.1.2 Signal flow from R to B**

The RF signal received at R may be either a single signal or a signal doubled (or multiplied) for a space (or/and angle) diversity of protection against adverse propagation phenomena.

The RF signal at reference point R contains STM-M signal together with an arbitrary RFCOH (if used). The RSPI function recovers data and associated timing at reference point B from the RF signal. The recovered timing is also made available at reference point T1 to the Synchronous Equipment Timing Source (SETS) for the purpose of synchronising the synchronous equipment reference clock if selected. The RFCOH, if present, is made available at reference point U50.

When the proper receiver thresholds are activated (e.g. by receiver power level or by error correction activity), radio specific managing data (e.g. ATPC increase/decrease power request from the local receiver function to be sent to the far end transmitter function or early warning switching request to the local Radio Protection Switching (RPS) or to be forwarded from a regenerative repeater to the next one) will be shown at K50 to functional block ROHA, which will provide for proper insertion in the media specific byte of RSOH or in RFCOH through reference points U1 or U50 respectively.

If the signal fails at reference point R or the input signal to the demodulation function fails, then the receive Loss of Signal (LOS) condition is generated and passed to reference point S50 and to the RST function at B. The signal at reference point R is considered to have failed when none of the receivers contained by a single receive function are able to present a signal of sufficiently high quality to enable the demodulation function to distinguish and recover the transmitted symbols.

#### 4.1.3 Application to the transmission of N times STM-N

The case of systems carrying more than one STM-N either by a multi-carrier technique or by single carrier with a bit rate N times STM-N, will be represented from the functional point of view by duplicating the RSPI functional block up to N times. It should be noted however that this does not imply any relationship with physical hardware implementation.

#### 4.2 Radio OverHead Access (ROHA)

The description of this function makes reference to figure 4a.

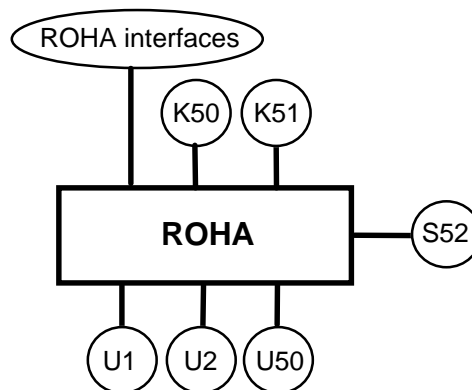

Figure 4a: ROHA functional block

This function gives external access to RFCOH bytes (from reference point U51) and to the SOH unused bytes (i.e. bytes reserved for future international standardisation, media specific bytes and, in agreement with the national user, national user bytes available from reference points U1 and U2) in order to provide radio specific controls and monitoring interfaces and wayside traffic.

Moreover, it supplies transmission interfaces K50 and K51 to functional blocks RSPI and RPS, respectively, allowing the required information exchange between corresponding radio terminals or regenerators for managing specific functions (e.g. ATPC) and the non-standardised switching control protocol to operate the RPS in the n+m configuration.

Data at K50 and K51 interfaces will be inserted/extracted into/from the dedicated media specific bytes of RSOH (available at reference point U1) or of RFCOH (available at reference point U50).

The ROHA function can provide 1+1 protection for the above mentioned signals.

The ROHA function recovers early warning switching requests of any foreseen threshold coming through the relevant bytes at reference points U1 or U50. It subsequently processes this information with the

equivalent bytes coming through reference point K50 from the local receiver and makes the results available for further forwarding to the next repeater (through the relevant bytes at U1 or U50) of the regenerative repeaters or, to functional block RPS (through reference point S52) in the radio terminals (see figure 4b).

When in the regenerator sections, wayside traffic signal up to 2 Mbit/s is provided on the SOH (as foreseen by ITU-R Recommendation 750 [3]), a possible functionality for ROHA is reported in the informative annex A.

Other indications at reference point S52 are described in the relevant operation and maintenance section.

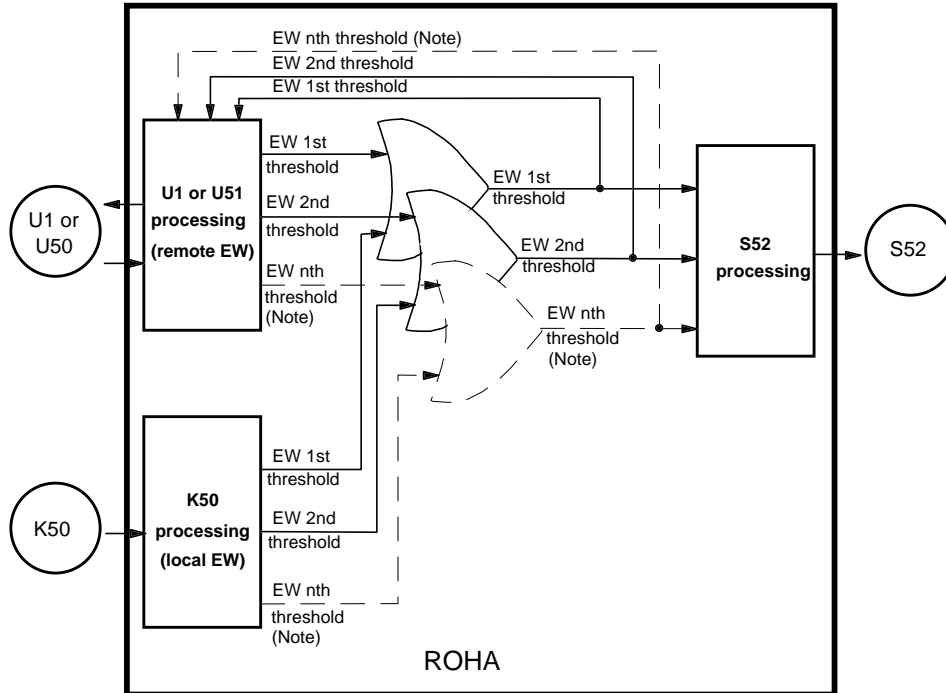

NOTE: High BER and low BER switching requests (if used) may be considered among EW thresholds.

Figure 4b: ROHA managing of early warning switching request

### 4.3 Radio Protection Switch (RPS)

The RPS function provides "m" protection channels for "n" STM-N signals against channel-associated failures, both for hardware failures and temporary signal degradation or losses due to propagation effects (e.g. rain or multipath phenomena) within a radio section (comprising a number of regenerative repeater sections).

Depending on the application and on the radio frequency band utilised, RPS may have to counteract multipath effects with hitless real time operation (e.g. within less than 10 ms from the detection of a switching initiation criterion).

Consequently, it should be noted that a Multiplex Section Protection (MSP) function, with its K1 & K2 protocols and procedures, is not suitable for the purpose of providing the n+m hitless radio protection switching as described. For the above mentioned reasons RPS functional block shall not use K1 & K2 bytes and protocols.

The RPS functions at both ends operate the same way, by monitoring the "n" STM-N signals through reference point S51 for failures and degradation. Evaluating the system status taking into account the priorities of failure conditions, the external assigned priority and remote switch requests, then switching the appropriate working channel to one of the "m" protection channels.

NOTE: The status information coming from S2, S3, S4, S50 and S52 of RST, MST, MSA, RSPI and ROHA respectively are shared through SEMF function. These switching information has, in general, dedicated hardware interfaces for real time operation, but for a logical description they are here considered as supervisory primitives at the S51 interface. Information from S3 and S4 may not be applicable due to the logical blocks sequence of some practical implementation (see annex D).

The two RPS functions: to activate the switching procedures and to share information on the channels status at both ends of the connection, communicate with each other via a non standardised protocol transmitted on a data communication channel at interface K51 made available by the ROHA function. This provides proper insertion/extraction in one of the "media specific bytes" or, as an alternative, in one of the RFOH bytes available at ref. points U1 or U50 respectively.

For 1+1 architecture, when no occasional traffic facility is foreseen, communication between the two corresponding RPS functions is not required. The working tributary is permanently bridged to both working and protection lines.

In any case, the RPS function may be considered as a specific connection matrix (similar to an HPC at VC-4 or STM-N level), where "X" reference points on either side are the same and may match any other along the functional block chain described in ITU-T Recommendation G.783 [7] because its process does not affect the nature of the characteristic information of the signal.

The signal flow associated with the RPS function is described with reference to a generic description of RPS functional block shown in figure 5.

At interface S51 the operation and maintenance primitives are described in the relevant section.

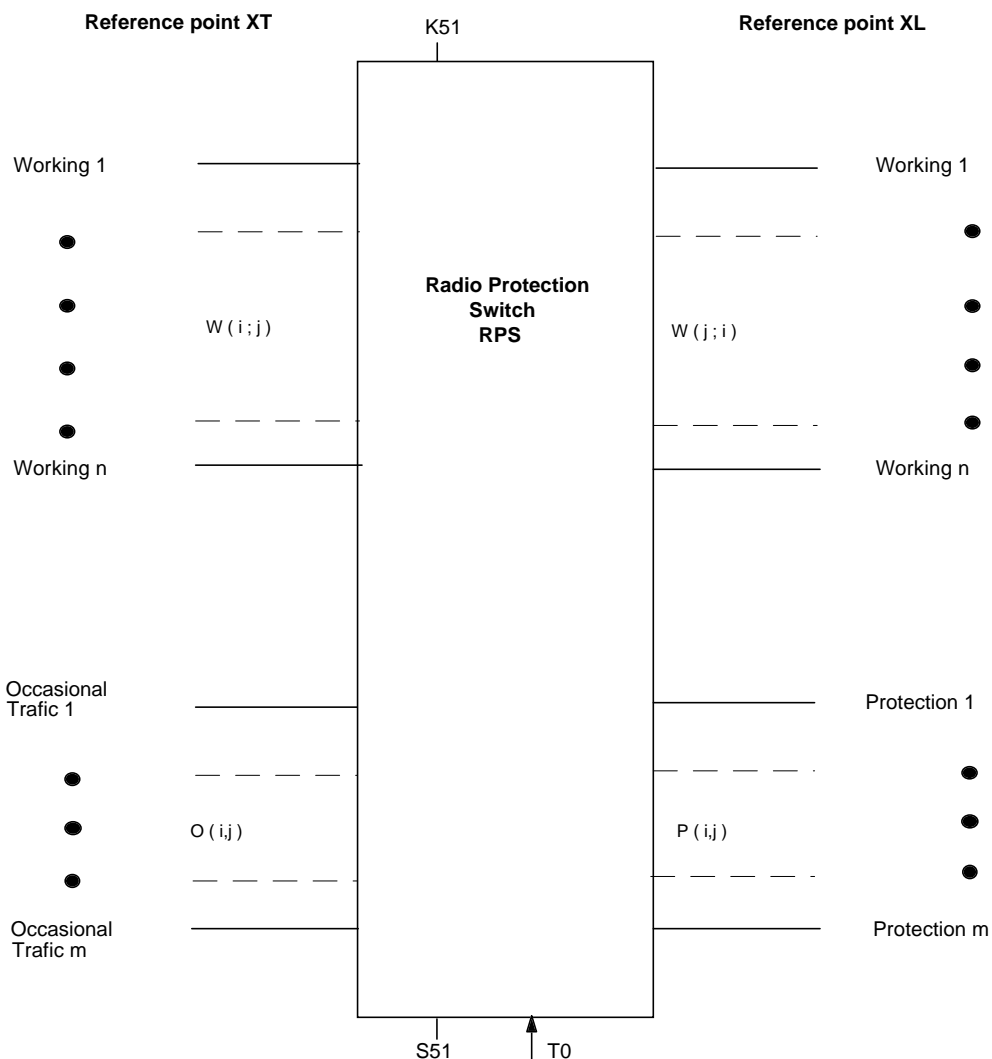

Figure 5: RPS functional block

4.3.1 Signal flow

The RPS function provides a connection matrix process not affecting the characteristic information of the signal applied at reference points XT and XL respectively (see informative annex D for implementation details).

The set of input and output ports is divided into two subsets, each containing both input and output ports X Line (XL) and X Tributary (XT) as shown in figures 5 and 6. This connection matrix allows interconnectivity as shown in table 1.

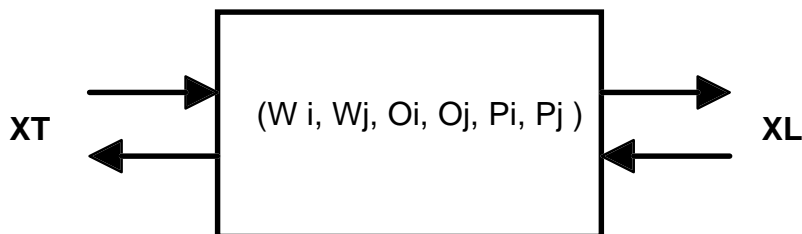

Figure 6: Connection matrix for RPS

The signals associated with the reference points XT and XL respectively are:

Tributary side, reference point XT:

- $W_i, W_j \quad i, j = 1..n$  working signals



- $O_i, O_j \quad i, j = 1..m$  occasional signals

Line side, reference point XL:

- $W_i, W_j \quad i, j = 1..n$  working signals
- $P_i, P_j \quad i, j = 1..m$  protection signals

where "i" indicates an incoming signal and "j" indicates an outgoing signal.

RPS provides a facility for re-addressing the "n" working signals (W) and the "m" occasional signals (O) at reference point XT to the "n" working signals (W) and the "m" protection signals (P) at reference point XL and vice versa. The RPS Connection Matrix allows interconnectivity as shown in table 1.

**Table 1: Connection matrix interconnectivity for RPS**

		Input		Output	
		XL	XT	XL	XT
Output	W <sub>j</sub>	—	i = j	—	—
	P <sub>j</sub>	—	☒	—	i = j
O <sub>j</sub>	XL	—	—	i = j	—
O <sub>j</sub>	XT	—	—	i = j	—

- ☒ : indicates that connection is possible for any j and i;
- i = j : indicates that connection is possible for the case that j = i only;
- : indicate that no connection is possible.

#### 4.3.2 Additional requirement on the signal flow from XT (tributary side) to XL (line side)

The "n" tributary signals (W<sub>i</sub>/XT), at STM-N or VC-4 level are doubled and sent to the corresponding working line and to a distributor (TxD) respectively.

When, through the data channel on interface K51, the corresponding RPS at the far end requires protection on a specific working channel, the local RPS bridges it from the TxD to one of the "m" protection lines.

When protection channels are available, up to "m" occasional tributaries may be allocated on the protection lines.

Any of the above operations may be also required by the SEMF function through the local F interface or a remote TMN.

#### 4.3.3 Additional requirement on the signal flow from XL (line side) to XT (tributary side)

When one of the working lines (W<sub>i</sub>/XL) is degraded or fails, the local RPS detects this condition through reference point S51 which shares information concerning EW thresholds exceeded, signal degrade, signal fail and RSPI failure available at SEMF on S2, S3, S50 and S52.

Consequently, the local RPS sends a request on the data channel at interface K51, to the far end corresponding RPS for a bridge on one of the "m" protection lines. It then waits until the content of the protection line is correct and finally switches the protection line input to the working tributary output.

If more than "m" working channels require protection at the same time, depending on the level of degradation and of priority given to the various lines and, if present, to the occasional signals, the lowest ones in priority will have access denied.

Occasional signals received on the "m" protection lines (Pj/XL) are addressed to the corresponding occasional tributary output (Oj/XT).

Any of the above operations may also be required by the SEMF function through the local F interface or a remote TMN/OS.

#### 4.3.4 Switching initiation criteria

Various levels of switching initiation may be foreseen. In any case they are described and prioritised according to the following general scheme.

The switching criteria have, in general, dedicated hardware interfaces for real time operation, but for a logical description, they are here considered as supervisory primitives as the S51 interface.

The use of particular AutoSwitch requests is conditioned by the logical allocation of the RPS function. Depending on implementation, switching initiation coming from functional blocks ( e.g. MSA and/or MST) logically allocated outside the RPS section are not applicable.

In any case equivalent proprietary AutoSwitch RPS requests should follow the specified scheme.

Priority	RPS Request
1 (highest)	Lockout
2	Forced Switch
3	AutoSwitch Signal Fail (SF)
4	AutoSwitch High Bit Error rate (HBER)
5	AutoSwitch Low Bit Error Rate (LBER)
6	AutoSwitch Early Warning (EW)
7	Manual Switch
8	Exercise

For RPS functions without hitless capability, AutoSwitch, LBER and EW requests are optional.

##### 4.3.4.1 Lockout

The Lockout RPS request is applicable to a working and to a protection channel. In the first case it prevents a working channel from being protected and in the second case it prevents a protection channel from being used for protection. The Lockout RPS request is generated by a command from the Local F interface (local lockout) or from the Q interface by TMN/OS (remote lockout) and is consequently forwarded to the RPS function by the MCF and SEMF functions via management reference point S51.

##### 4.3.4.2 Forced switch

The Forced Switch RPS request is generated by a command from the Local F interface (local forced switch) or from the Q interface by TMN/OS (remote forced switch) and is consequently forwarded to the RPS function by the MCF and SEMF functions via management reference point S51.

##### 4.3.4.3 Autoswitch signal fail

An autoswitch signal fail request may be generated by detection of a logical OR of the following defects: RSPI, Loss of Signal and failures A1/A2, LOF, MS-AIS, AU-AIS and LOP. Depending on the application, use of a subset of them is allowed. Use of other proprietary indications that have an equivalent weight is also allowed.

##### 4.3.4.4 Autoswitch HBER and LBER

Autoswitch HBER and LBER RPS requests may be generated by excessive error and SD information respectively derived from the local MST. For RPS purposes, equivalent HBER and LBER indications (e.g.

derived from RSPI along the radio switching section with EW methodology) may alternatively be used as switch initiation criteria. The detection thresholds for HBER and LBER should, in this case, not be worse than the excessive error and SD thresholds respectively.

#### 4.3.4.5 Autoswitch EW

An autoswitch EW RPS request is generated by proprietary early warning threshold crossing detected by the local or remote RSPI along the radio switching section. EW requests may be also generated by detection of a logical OR of different EW types.

#### 4.3.4.6 Manual Switch

Manual switch RPS request is generated by a command from the Local F interface (local manual switch) or from the Q interface by TMN/OS (remote manual switch and is consequently forwarded to the RPS function by the MCF and SEMF functions via management reference point S51.

#### 4.3.4.7 Exercise

Exercise is an optional RPS request which may be used to test the RPS function by initiating an RPS process without actual switching. Exercise may be initiated either by the local control terminal at the F-interface or by TMN/OS at the Q interface and is consequently forwarded to the RPS function by MCF and SEMF functions via management reference point S51.

#### 4.3.5 Switching time

For hitless switching performance against fast multipath propagation phenomena, the total switching time, from the detection of an initiation criterion should be less than 10 ms, including the propagation time of the information flow between the corresponding RPS for switching procedure activation.

In any other case switching time should be less than 50 ms from the switching criterion detection.

#### 4.3.6 Switch restore

The switch restore procedure is performed by the RPS function on the basis of the following requests:

Priority	RPS switch restore request.
1	Forced restore of a channel under protection
2	Automatic forced restore of a channel under protection
3	Automatic switch restore request from a channel under protection

##### 4.3.6.1 Forced restore

The forced restore RPS request is generated by a command from the Local F interface (local forced restore) or from the Q-interface by TMN/OS (remote forced restore), which is consequently forwarded to the RPS function by the MCF and SEMF functions via management reference point S51.

##### 4.3.6.2 Automatic forced restore

Automatic forced restore of a channel under protection occurs when all protection channels are occupied and another working channel, with an RPS request priority higher than one of the currently protected working channels, requires access to a protection channel. In this case the protected channel with the lowest RPS request priority will be restored to its normal working channel.

##### 4.3.6.3 Automatic switch restore

The RPS automatic switch restore request occurs, for the channel under protection, as soon as none of the RPS requests are active in the corresponding normal working channel. On receipt of this request, the RPS functional block performs the switch restore.

## 5 Requirement of operation and maintenance

The radio specific functional blocks, namely RSPI, RPS and ROHA, will supply the SEMF functional block, through S50, S51 and S52 reference points respectively, the anomalies and defects indications that are reported in tables 2, 3 and 4 together with the consequent actions.

### 5.1 RSPI requirements

The indications provided by functional block RSPI (see figure 3) are described as follows:

**lossOfSignal(mod):** This indication shall indicate a loss of the incoming data for the modulation function. The indication is used in case of split indoor/outdoor RSPI functions, it is therefore optional.

**modulationFail:** This indication shall report the internal failures of the modulation function affecting the modulated signal and the loss of incoming data to the modulation function.

**txFail:** This indication shall indicate a failed transmitted signal caused by internal failure of the transmit function.

**txLOS:** This indication shall indicate a loss of the incoming signal for the transmitting function (TX). When the distinction between txFail and txLOS can not be carried out with a sufficient degree of confidence, the use of txFail indication shall be preferred, therefore this indication is optional.

**lossOfSignal(rx):** This indication shall report a loss of the incoming signal at reference point R for the RX function. When the distinction between rxFail and lossOfSignal(rx) can not be carried out with a sufficient degree of confidence, the use of rxFail indication shall be preferred, therefore this indication is optional.

**rxFail:** This indication shall report the internal failures of the RX function affecting the received signal.

**demLOS:** This indication shall indicate a loss of the incoming data for the demodulation function. When the distinction between demodulationFail and demLOS can not be carried out with a sufficient degree of confidence, the use of demodulationFail indication shall be preferred, therefore this indication is optional.

**demodulationFail:** This indication shall report the internal failures of the demodulation function affecting the demodulated signal.

The following primitives are also optionally envisaged to be accessed via reference point S50 for maintenance operation purposes:

**receivedLevelRequest:** Returns the received power level at reference point R detected by the Rx-function. When a single Receive-function comprises more than one receiver for diversity redundancy, receivedLevelRequest will address each receiver in order to return its detected received power level.

**ATPC Status:** Returns the ATPC status of the TX-function as "ATPC implemented/not implemented" and "ATPC enabled/disabled".

**ATPC Enable:** Command to enable/disable ATPC for the TX-Function, provided when ATPC is implemented.

**Transmitted level request:** Returns the monitored transmitter output power at reference point R for the TX-function.

**Table 2: Radio synchronous physical interface**

Signal Flow	Anomalies and defects	Report across	SEMF filtering		Consequent actions
		S50	Alarm	Performance	All ONE's (AIS) inserted at reference point C
From R to B	lossOfSignal(rx) (Note)	Yes	Yes		Yes
	rxFail	Yes	Yes		Yes
	demLOS (Note)	Yes	Yes		Yes
	demodulationFail	Yes	Yes		Yes
From B to R	LossOfSignal(mod) (Note)	Yes	Yes		
	modulationFail	Yes	Yes		
	txLOS (Note)	Yes	Yes		
	txFail	Yes	Yes		

NOTE: These indications are optional, for further information see the text above.

**Table 3: RSPI Optional command, configuration and provisioning information flow over S50 reference points**

S reference point	GET	SET
S50 (RSPI)	ATPC status	ATPC enable
	Transmitted level	
	Received level	

**5.2 RPS requirements**

The following primitives are envisaged to be accessed via reference point S51 for maintenance and operation:

- RPS Fail. RPS Fail should be declared when the RPS function is no longer able to protect one or more of the protected channels;
- PSECh# (Protection Switching Events for channel 1.....n).  
 This indication reports the number of switching events for channel number # in a suitable time base. However this parameter is for future study;
- FPRECh# (Failed Protection Switching Events for channel 1.....n).  
 This indication reports the number of failed switching events for channel number # in a suitable time base. However this parameter is for future study;
- SWITCH STATUS.  
 This indication reports the situation of alarm and commands active on the RPS;
- CHANNEL STATUS.  
 This indication reports RPS request/failure (see subclause 3.3.2 switching initiation criteria) condition active on channel #.

Where the symbol # refers to the channel number identifier (# = 1..n or 1..m).

In table 4 the related SEMF filtering and consequent actions are shown meanwhile table 5 shows the "GET" and "SET" command and configuration provisioning.

**Table 4: Radio protection switch operation and maintenance functions**

Signal Flow	Anomalies and defects	Report across	SEMF filtering		Consequent actions
		S51	Alarm	Performance	
From XT to XL and From XL to XT	RPS Fail	Yes	Yes		
	FPRE Ch# (*)	Yes			
	PSE Ch# (*)	Yes			

(\*) for further study

**Table 5: Command, configuration and provisioning information flow over S reference points**

S reference point	GET	SET
S51 (RPS)	SWITCH STATUS	
	CHANNEL STATUS	
		Lockout
		Forced Switch
		Manual Switch
		Exercise

**5.3 ROHA requirements:**

The following primitives may be reported to interface S52, to SEMF alarm filtering, for service/wayside channel network maintenance:

**lossOfSignal#(in):** This indication is optional and reports the loss of input signal (Tx side) for service/wayside channel number #.

## **6 Performance monitoring**

The performance monitoring requirements specific to the management of DRRS Network Elements (NE) are outside the scope of the present prETS. However all DRRS shall support the common performance requirements given for all other SDH equipment.

## **Annex A (informative): RPS practical implementations**

In this annex some practical implementations of RPS with hitless functionality are described together with some comments about its functionality and characteristics.

Hitless functionality is one of the most relevant topics in SDH radio, due to the requirement in regenerative repeaters to perform frame alignment on the A1-A2 bytes which due to the frame loss and recovery procedures during the change of signals content on the protection channel(s), which may introduce, on very long distance multi-hop radio connection, unacceptable delay on the switching time required for hitless functionality during heavy multipath activity.

In n+m RPS with hitless functionality implementations, no termination of the Multiplex Section (MS) may be possible if the number of regenerator sections between radio terminals with RPS is limited. This is to ensure that the total time of detect/restore the A1/A2 frame loss/alignment of the repeater chain will not affect the total switching time over the required minimum to ensure efficient hitless protection.

Having no limitation in the number of cascaded regenerative repeaters, implies that (at least in the media-changing locations) a MSA function is needed (no mixed-media MS may be foreseen).

The more common types of RPS are shown in the four block diagrams in figure A.1. These are treated in greater detail in figure A.2.



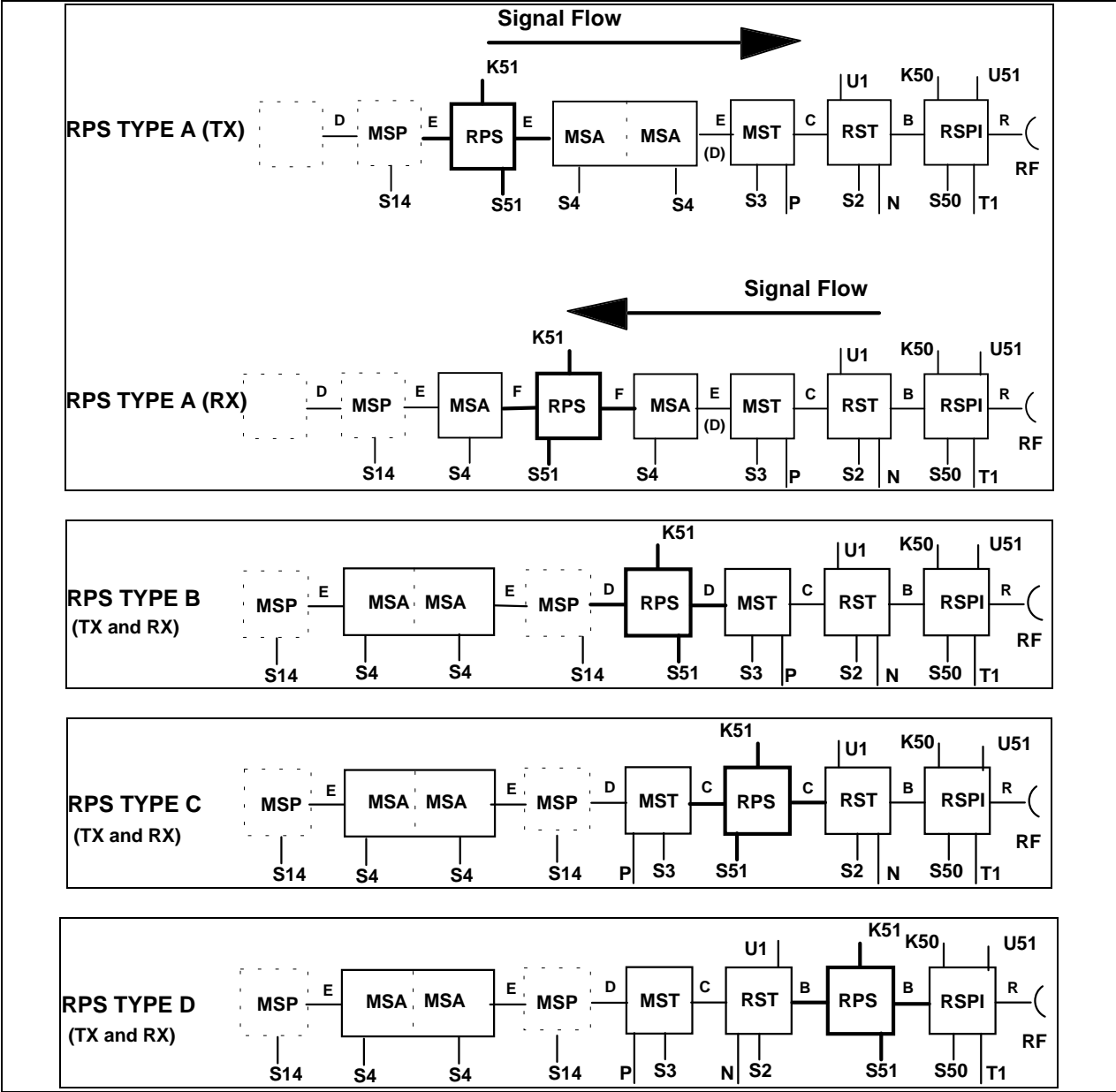

Figure A.1: Possible logical allocation of the RPS functional block

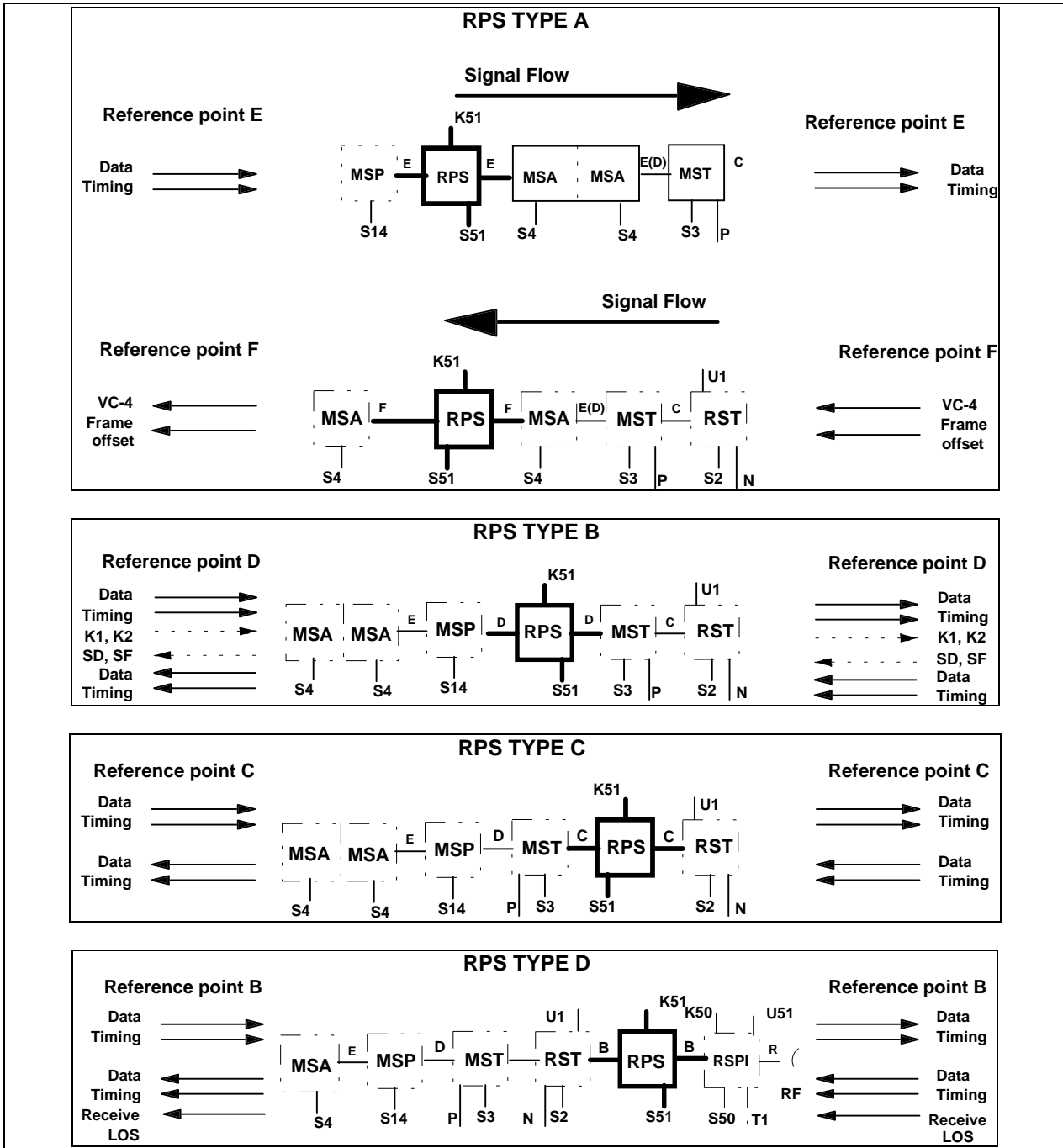

Figure A.2: Possible reference points of the RPS functional block

## A.1 Signal flow and main functionality

### A.1.1 RPS type A

The signals split and distribution in the TX side is performed before the MSA function so that, when a protection channel is required, the change of payload on the protection channel is recovered by the pointer adjustment mechanism without affecting the frame word location.

As a consequence, given that the content of the working and standby signal is different at STM level, the receiver side alignment and switching of working and standby channels is performed at Virtual Container (VC) level, in a similar way to that performed by the HPC function.

Due to the logical allocation of the RPS function, this type A is not suitable for use in conjunction with the MSP function, but network protection if required, will be performed at VCn level by the HPC or LPC functions.

#### **A.1.2 RPS type B**

The TX side MSA functions are all synchronised, both in frequency and frame phase, so that the standby channel frame alignment is never affected when different signals are sent on it.

The receiver side alignment and switching between working and standby channels is performed at STM level taking suitable precautions against the possible difference in the content of SOH (e.g. skipping the bit to bit comparison during the time frame of SOH location).

#### **A.1.3 RPS type C**

When a radio switching section coincides with a MS, the TX side MSA functions are all synchronised, both in frequency and frame phase, so that the standby channel frame alignment is never affected when different signals are sent on it.

The receiver side alignment and switching between working and standby channels is performed at STM level, taking suitable precautions against the possible difference in the content of SOH (e.g. skipping the bit to bit comparison during the time frame of SOH location).

This type of RPS may not use switching initiation extracted from bip-24 evaluation criterion so that no SDH path quality criteria may be used for switching initiation, unless RPS performs B2 parity evaluation monitoring as its internal functionality.

Provided that the number of regenerators between the two corresponding RPS functions are kept to a reduced amount, this type C RPS is suitable for n+m protection with hitless functionality also in SDH regenerator sections (without MSA and MST functions, so that the multiplex section is not terminated, thus allowing mixed media MS).

#### **A.1.4 RPS type D**

When an RPS is inserted at reference point B, all switching initiation criteria are derived from the RSPI. It can only be used for protecting a single regenerator section link connection.

**Annex B (informative): Example of ROHA SOH managing of 2 Mbit/s wayside traffic in the regenerator sections**

When in the regenerator sections, a wayside traffic signal up to 2 Mbit/s is provided, making provisional use of unused RSOH and MSOH bytes and in agreement with the national user, of the national use bytes (as foreseen by ITU-R Recommendation 750 [3]), the ROHA functional block will manage a suitable redundancy providing even parity (\*) in the data inserted into MSOH, in order not to corrupt B2 parity along the multiplex section; this functionality is shown in figure B.1.

(\*) At the terminals ROHA forces the same even parity on these bytes (MST function leaves these bytes with an arbitrary content as foreseen by ITU-T Recommendation G.783 [7]).

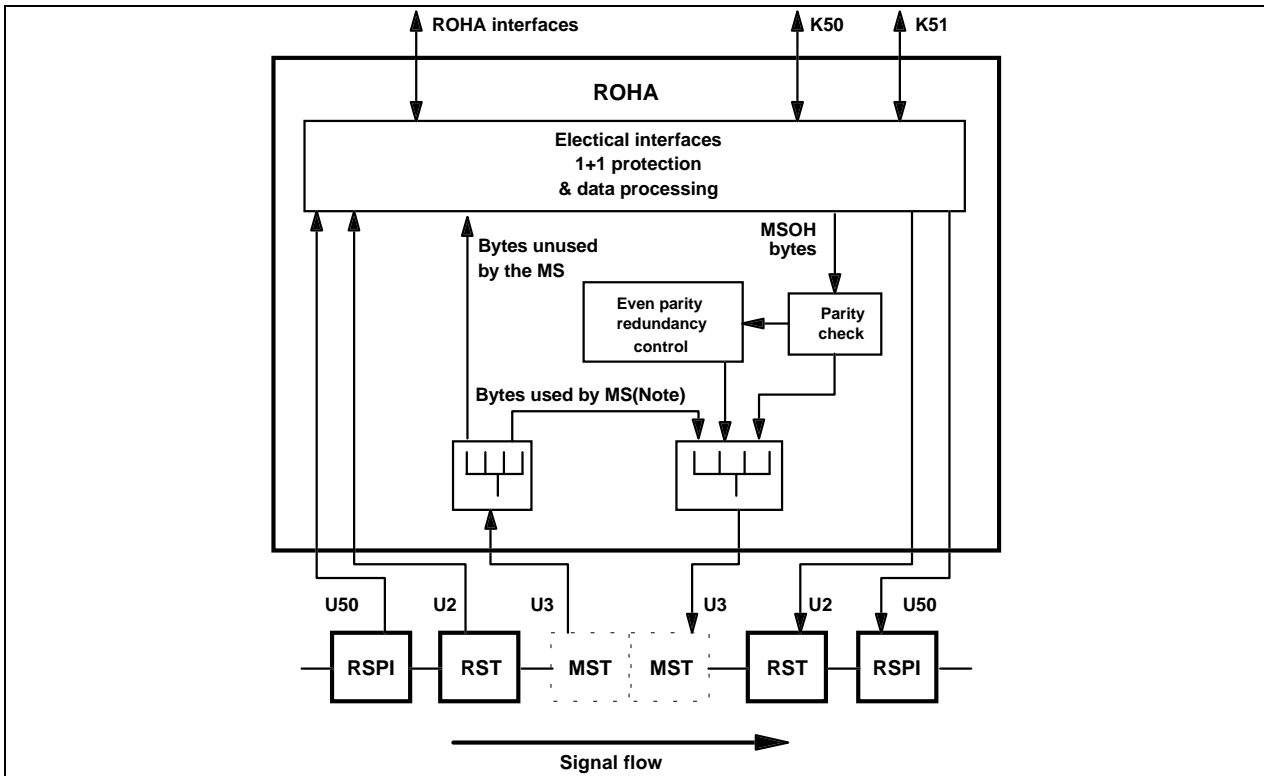

NOTE: The bytes used by the MS are those of columns 1, 4 and 7 of MSOH plus B2, Z1, Z2, M1. Any other bytes which use ITU-T Recommendation G.783 [7] will be standardised in future, as will (if used) the bytes for national use.

**Figure B.1: ROHA operation on MSOH bytes when used in radio RS**

**Annex C (informative): Description of the transport network architecture based on SDH DRRS**

**C.1 Basic concepts**

ITU-T Recommendation G.803 [9] and ETS 300 417 [1] give a methodology which allows a formal description of an SDH transport based network. The present informative annex highlights this concept, for more detailed information please refer to the above mentioned documents.

The network is viewed as a matrix structure. The vertical direction is obtained by a layering process which reflects the SDH multiplexing structure (see figure C.1).

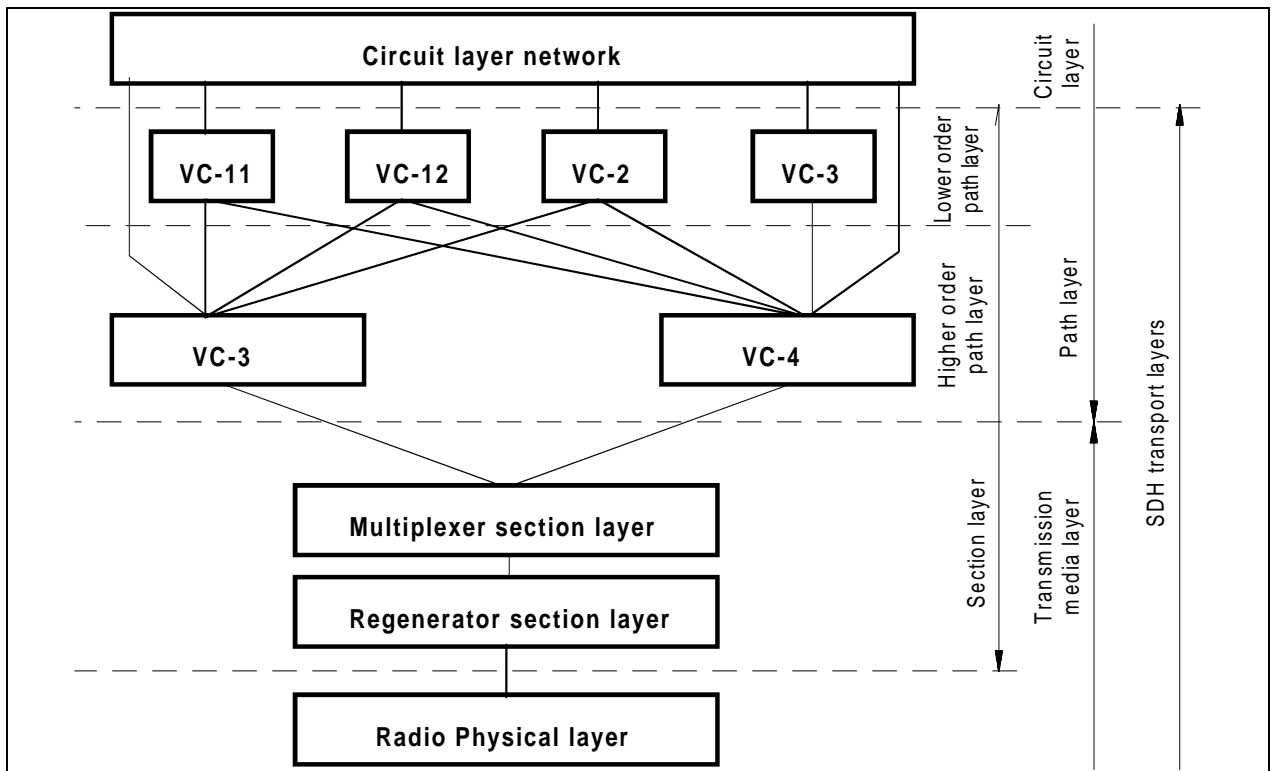

**Figure C.1: SDH - based transport network layered model**

The horizontal direction is obtained by a partitioning process which reflects the topological structure of each layer. The basic topological components are: network connection, sub-network connection and link connection. Each layer has its own characteristic information and there is a client server relationship between adjacent layers. Information transport from one point to another within the same layer is performed by the server (lower) layer by means of transmission functions. Three basic transmission functions, referred to as atomic functions, have been identified:

**Adaptation Function:** is responsible for the adaptation of the different characteristic information flowing within two adjacent layers;

**Trail Termination:** is responsible for the integrity of characteristic information transported between two points in the same layer. Information integrity may be ensured by monitoring processes (e.g. B1, B2, B3, byte processing);

Connection Function: is responsible for the connection between the trail termination function and the server adaptation function. The connection function may perform cross connection of characteristic information within a Layer.

Figure C.2 shows, as an example, a PDH 140 Mbit/s to an SDH STM-1 multiplexing scheme depicted using the above explained concepts.

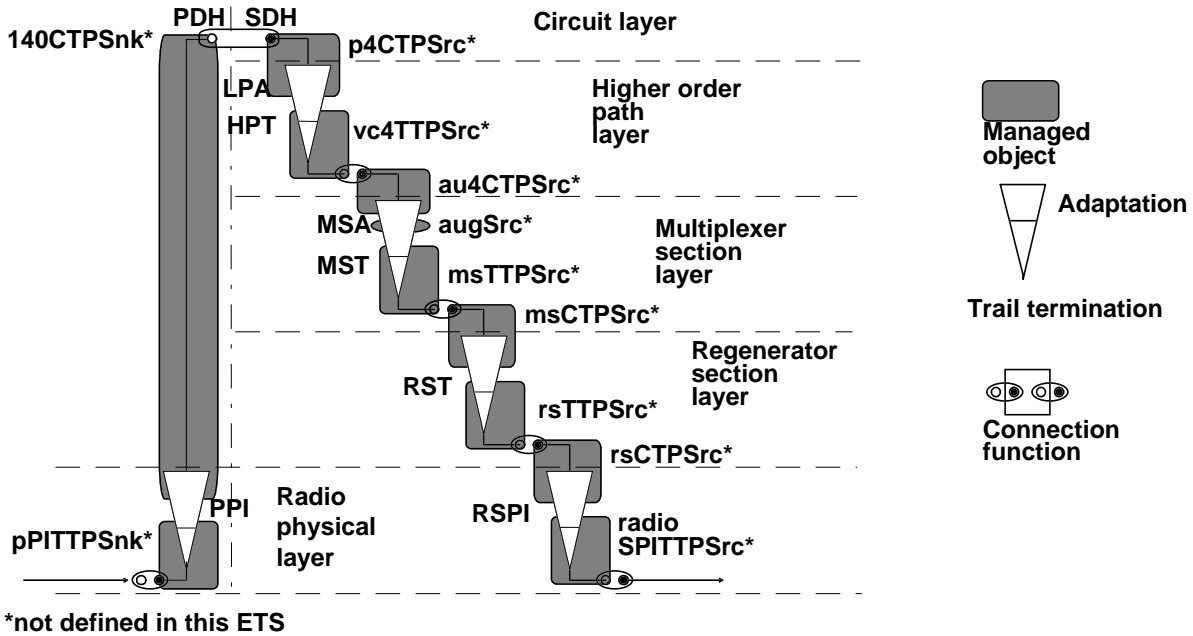

Figure C.2: EXAMPLE: 140 Mbit/s signals multiplexed to STM-1 signal

The figure shows also the relationship with ITU-T Recommendation G.783 [7] functional blocks and the corresponding managed object classes.

Figure C.3 shows how two radio hops may implement a multiplex section trail.

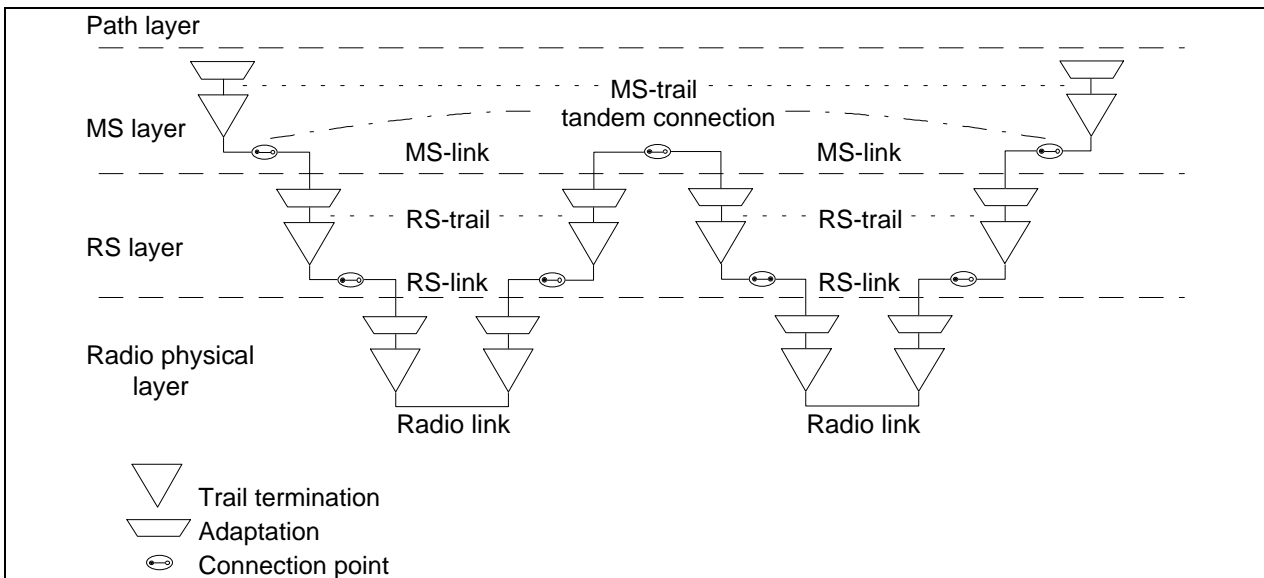

Figure C.3: ITU-T Recommendation G.783 [7] functional blocks and the corresponding managed object classes example

The MS-trail at MS-layer is composed of a MS-tandem connection made up of two MS-link connections. Transport of MS characteristic information (a logic STM-1 signal with RSOH bytes undefined) along the MS tandem connection is monitored for integrity by the MS trail termination function by means of B2 processing.

Transport on each MS link connection is performed by the server layer (Regenerator Layer (RS) layer).

The regenerator layer topology for this case is composed by two regenerator section trails, each of them made up by one single RS link connection. Transport of RS characteristic information (a logic fully formatted STM-1 signal ) along the RS link connection is monitored for integrity by the RS trail termination function by means of B1 processing.

Transport on each RS link connection is performed by the server layer (radio physical layer).

The physical layer topology for this case is composed by two radio physical section trails, each of them made up by one single radio link connection.

## C.2 Radio specific atomic functions

As defined in ETS 300 417 [1], the naming of the atomic functions shall be of the form:

<layer>/<client layer>_A[<direction>]	for an adaptation function;
<layer_TT[_<direction>]	for a trail termination function;
<layer>_C	for a connection function.

Please refer to ETS 300 417 [1] for a complete definition of the information naming scheme

### C.2.1 RSPI related atomic functions

The following atomic functions are used in association with the RSPI functional block:

- RRS1/RS1\_A\_So            radio relay STM-1 layer to regenerator section STM-1 layer; adaptation source
- RRS1/RS1\_A\_Sk            radio relay STM-1 layer to regenerator section STM-1 layer; adaptation sink
- RRS1/RFCOH\_A\_So        radio relay STM-1 layer to radio overhead access layer adaptation; source
- RRS1/RFCOH\_A\_Sk        radio relay STM-1 layer to radio overhead access layer adaptation; sink
- RRS1\_TT\_So                radio relay STM-1 layer trail termination source;
- RRS1\_TT\_Sk                Radio relay STM-1 layer Trail termination sink.

The naming of the physical layer (for the STM1 signal) as RRS1 is used to correspond to the ETS 300 417 [1] terminology which uses ES for Electrical Section and OS for Optical Section. STM-4 and STM-16 radio physical layers would consequently be named RRS4 and RRS16 respectively.

In figure C.4 the above defined atomic functions are depicted in the ITU-T Recommendation G.803 [9] style with the associated RSPI alarm indications.

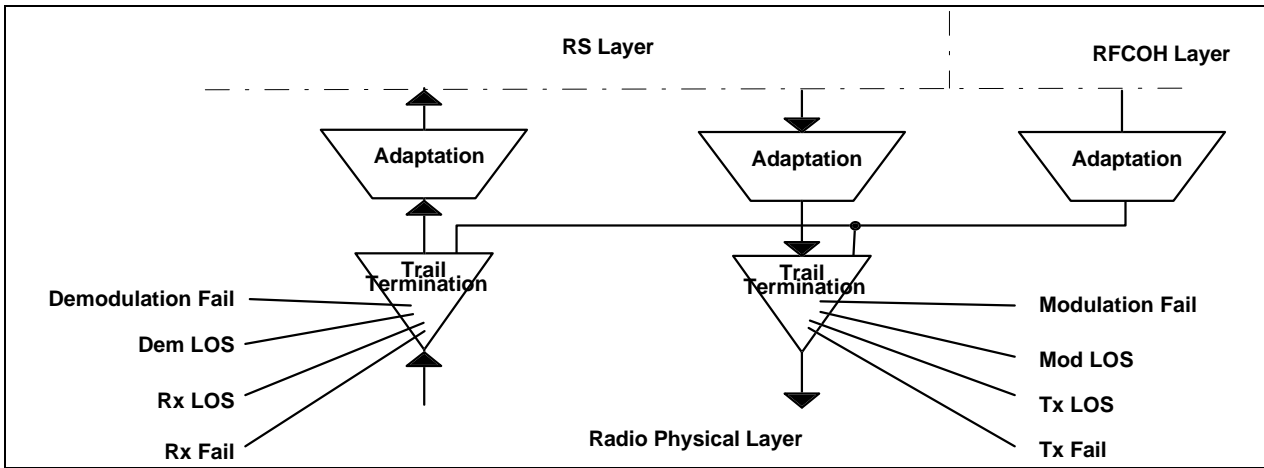

Figure C.4: RSPI atomic functions

C.2.2 RPS related atomic functions

ITU-T Recommendation G.803 [9] allows two types of protection schemes:

- trail protection (figure C.5);
- sub-network connection protection (figure C.6).

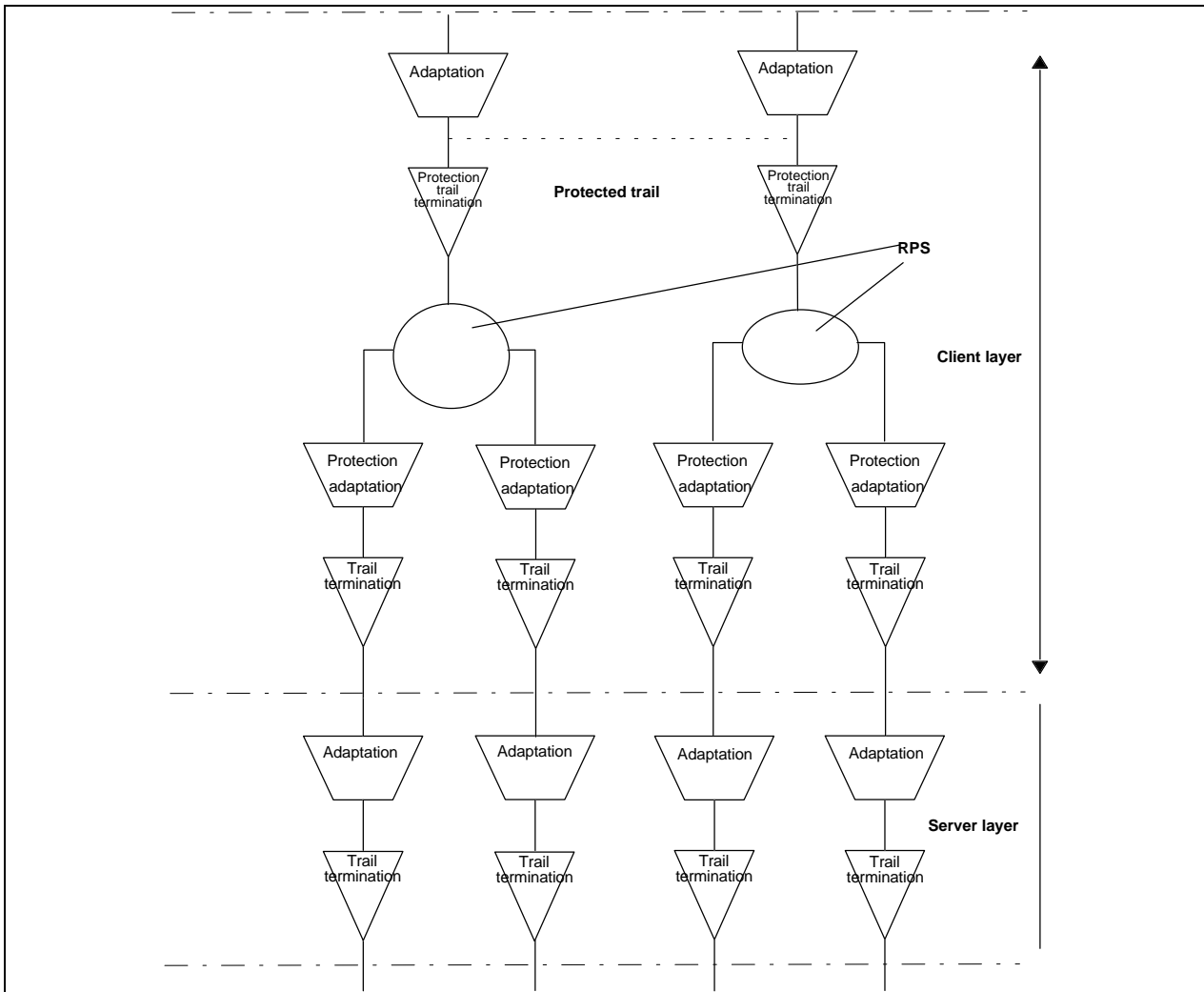
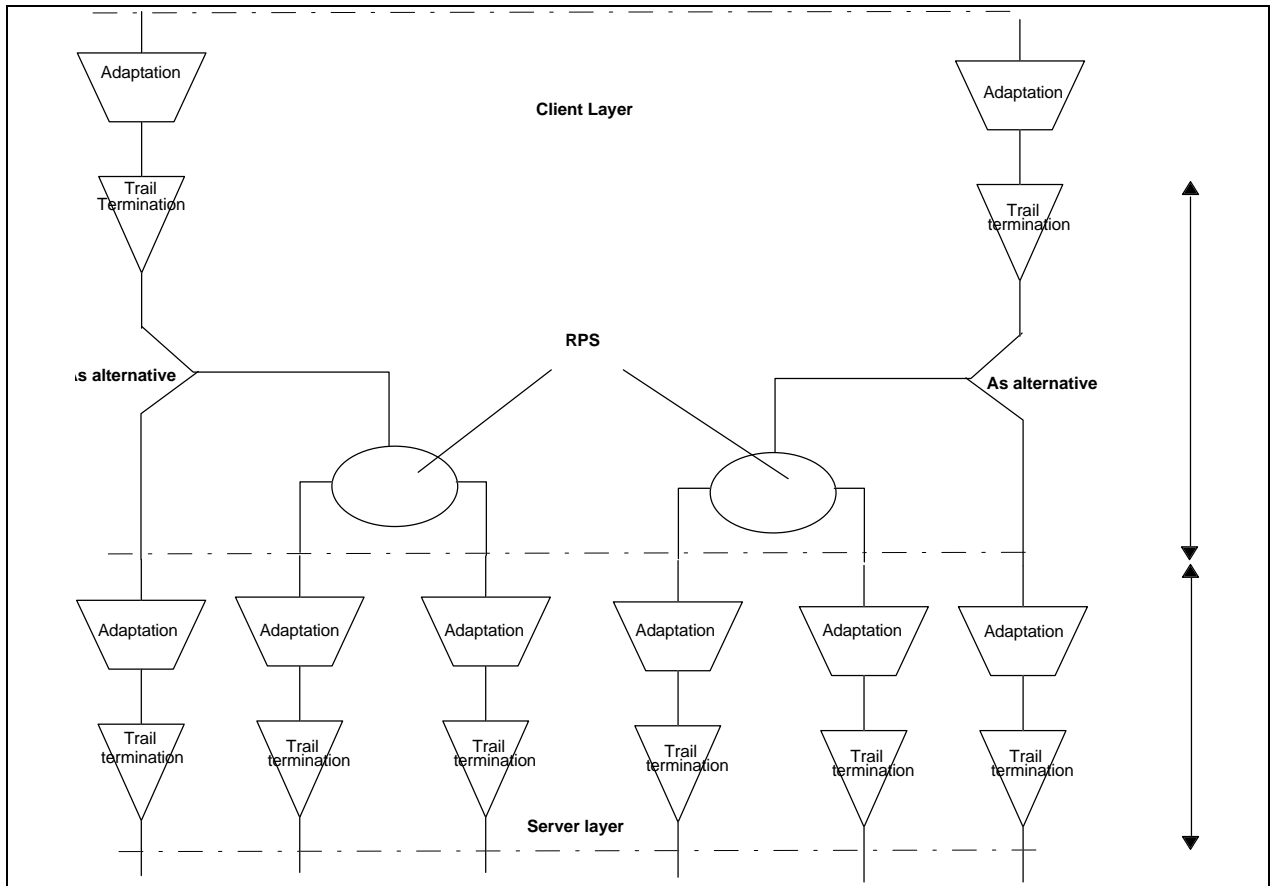

Figure C.5: Trail protection scheme





**Figure C.6: Sub-network connection protection scheme**

The following atomic functions may be used in association with the RPS function block, where Connection refers to the sub-network connection scheme as depicted in figure C.6 and protection Connection refers to trail protection scheme as depicted in figure C.5:

- RS1\_C STM1 Regenerator Section Connection;
- RS1P\_C STM1 Regenerator Section Protection Connection;
- MS1\_C STM1 Multiplex Section Connection;
- MS1P\_C STM1 Multiplex Section Protection Connection;
- S4\_C VC4 Connection.

## Annex D (informative): Bibliography

- ITU-T Recommendation G.774: "Synchronous digital hierarchy SDH management information model for the network element view".
- ITU-T Recommendation M.3100: "Generic network information model".
- ITU-T Recommendation X.701: "Information technology - Open System Interconnection - Systems management overview".
- ITU-T Recommendation X.710: "Common management information service definition for CCITT applications".
- ITU-T Recommendation X.711: "Common management information protocol specification for CCITT applications".
- ITU-T Recommendation X.720: "Information technology - Open System Interconnection - Structure of Management Information : Management information model".
- ITU-T Recommendation X.721: "Information technology - Open System Interconnection - Structure of Management Information : Definition of Management Information".
- ITU-T Recommendation X.722: "Information technology - Open System Interconnection - Structure of Management Information : Guidelines for the definition of managed objects".
- ITU-T Recommendation X.730: "Information technology - Open System Interconnection - Systems Management : Object management function".
- ITU-T Recommendation X.731: "Information technology - Open System Interconnection - Systems Management : State management function".
- ITU-T Recommendation X.733: "Information technology - Open System Interconnection - Systems Management : Alarm reporting function".
- ITU-T Recommendation X.734: "Information technology - Open System Interconnection - Systems Management : Event report management function".
- ITU-T Recommendation X.735: "Information technology - Open System Interconnection - Systems Management: Log control function".

## History

Document history	
July 1995	Public Enquiry PE 88: 1995-07-24 to 1995-11-17
May 1996	Converted into Adobe Acrobat Portable Document Format (PDF)