



EUROPEAN
TELECOMMUNICATION
STANDARD

DRAFT
pr **ETS 300 633**

July 1995

Source: ETSI TC-TM

Reference: DE/TM-04034

ICS: 33.080

Key words: Capacity, point-to-point, digital radio relay, 2,1 to 2,6 GHz

**Transmission and Multiplexing (TM);
Low and medium capacity point-to-point digital radio-relay
systems operating in the 2,1 to 2,6 GHz frequency band**

ETSI

European Telecommunications Standards Institute

ETSI Secretariat

Postal address: F-06921 Sophia Antipolis CEDEX - FRANCE

Office address: 650 Route des Lucioles - Sophia Antipolis - Valbonne - FRANCE

X.400: c=fr, a=atlas, p=etsi, s=secretariat - **Internet:** secretariat@etsi.fr

Tel.: +33 92 94 42 00 - Fax: +33 93 65 47 16

Copyright Notification: No part may be reproduced except as authorized by written permission. The copyright and the foregoing restriction extend to reproduction in all media.

© European Telecommunications Standards Institute 1995. All rights reserved.

Contents

| | |
|---|----|
| Foreword..... | 5 |
| 1 Scope | 7 |
| 2 Normative references | 7 |
| 3 Abbreviations and symbols..... | 9 |
| 3.1 Abbreviations | 9 |
| 3.2 Symbols | 9 |
| 4 General characteristics..... | 9 |
| 4.1 Frequency bands and channel arrangements | 9 |
| 4.2 Modes of operation | 9 |
| 4.2.1 Channel spacing..... | 10 |
| 4.2.2 Transmit / receive separation band | 10 |
| 4.2.3 Transmit / receive duplex frequency separation..... | 10 |
| 4.3 Installation..... | 10 |
| 4.3.1 Environmental conditions | 10 |
| 4.3.1.1 Equipment within weather protected locations | 10 |
| 4.3.1.2 Equipment for non-weather protected locations | 10 |
| 4.3.2 Electromagnetic compatibility conditions..... | 10 |
| 4.3.3 Power supply | 11 |
| 4.4 TMN Requirements..... | 11 |
| 4.5 Block Diagram..... | 11 |
| 4.6 Mechanical specifications for RF interfaces | 11 |
| 5 Baseband characteristics | 12 |
| 5.1 Plesiochronous Digital Hierarchy interfaces | 12 |
| 5.2 Analogue interfaces | 12 |
| 6 Transmitter characteristics | 12 |
| 6.1 Output power..... | 12 |
| 6.2 RF spectrum masks..... | 12 |
| 6.3 Spectral lines at the symbol rate..... | 12 |
| 6.4 Spurious emissions..... | 13 |
| 6.5 Radio frequency tolerance | 13 |
| 6.6 Return loss..... | 13 |
| 7 Receiver characteristics | 13 |
| 7.1 Receiver image rejection | 13 |
| 7.2 Receiver spurious emissions | 13 |
| 7.3 Input level range..... | 13 |
| 7.4 Return loss..... | 13 |
| 8 System characteristics | 14 |
| 8.1 BER as a function of receiver input level | 14 |
| 8.2 Equipment background BER..... | 15 |
| 8.3 Interference sensitivity | 15 |
| 8.3.1.1 Method of testing like interferer W/U | 15 |
| 8.3.1.2 Reference points..... | 15 |
| 8.3.2 Co-channel interference | 15 |
| 8.3.3 Adjacent channel interference..... | 15 |
| 8.3.4 CW spurious interference..... | 16 |
| 9 Feeder / antenna requirements | 16 |

Annex A (informative): Indicative channel capacities 18

History 19

Foreword

This draft European Telecommunication Standard (ETS) has been prepared by the Transmission and Multiplexing (TM) Technical Committee of the European Telecommunications Standards Institute (ETSI) and is now submitted for the Public Enquiry phase of the ETSI standards approval procedure.

| Proposed transposition dates | |
|---|---------------------------------|
| Date of latest announcement of this ETS (doa): | 3 months after ETSI publication |
| Date of latest publication of new National Standard or endorsement of this ETS (dop/e): | 6 months after doa |
| Date of withdrawal of any conflicting National Standard (dow): | 6 months after doa |

Blank page

1 Scope

This European Telecommunications Standard (ETS) specifies the minimum performance parameters for terrestrial low and medium capacity Point-to-Point (P-P) digital fixed service digital radio communications equipment operating in the 2,1 to 2,6 GHz frequency bands.

Digital systems are intended to be used for point-to-point connections in local and regional networks at data rates between Nx64 kbit/s, Nx2 Mbit/s (N=1,2,4,8,16), 2x8 Mbit/s and 34 Mbit/s. Other data rates may also be foreseen. Typical applications include:

- a) customer connections;
- b) Integrated Services Digital Network (ISDN) extension;
- c) mobile base station connections;
- d) telemetry and telecontrol, including transportable and off-shore use;
- e) digital TV application.

Systems considered in this ETS shall be able to respect CCITR high, medium and local grade performance objectives, i.e. CCITR Recommendations 634, [17] 696 [4], 697 [5], CCITT Recommendation G.821 [7] and the forthcoming performance objectives detailed in ITU-T Recommendation G.826 [8].

The parameters to be specified fall into two categories:

- a) Those that are required to provide compatibility between channels from different sources of equipment on the same route, connected either to:
 - separate antennas, or to
 - separate polarisations of the same antenna.
- b) Parameters defining the transmission quality of the proposed system.

The standardization deals with Intermediate Frequency (IF), Radio Frequency (RF) and baseband characteristics relevant to low capacity Plesiochronous Digital Hierarchy (PDH) transmission. Antenna/feeder system requirements are covered in ETS 300 631 [12].

Due to the wide spread of applications and corresponding system rates, parameters such as RF spectrum masks and receiver sensitivity are related to standardised channel spacings rather than to minimum system rates. This allows individual countries to allocate a bandwidth and therefore a standard channel spacing in accordance with the foreseen services and their own frequency management and radio network planning.

As the maximum transmissible rate in a given bandwidth depends on systems spectral efficiency, different equipment classes are defined:

| | |
|---------|---|
| Class 1 | equipment based on a minimum of 2-level modulation scheme (e.g. 2-FSK, GMSK with discriminator detection, or equivalent); |
| Class 2 | equipment based on a minimum 4-level modulation scheme (e.g. 4-FSK, 4-QAM, or equivalent); |
| Class 3 | equipment based on a minimum 16-level modulation scheme (e.g. 16-QAM, or equivalent). |

2 Normative references

This ETS incorporates, by dated or undated reference, provisions from other publications. These normative references are cited at the appropriate place in the text and the publications are listed hereafter. For dated references, subsequent amendments to, or revisions of, any of these publications apply to this ETS only when incorporated in it by amendment or revision. For undated references, the latest edition of the publication referred to applies.

- [1] CEPT Recommendation T/R 13-01: "Preferred channel arrangements for fixed services in the range 1 - 3 GHz".

- [2] ETS 300 019, Parts 1 and 2 (1994): "Equipment Engineering (EE); Environmental conditions and environmental tests for telecommunications equipment Part 1-1 to 1-7: Classification of environmental conditions, Part 2-1 to 2-7: Specification of environmental tests".
- [3] CCITT Recommendation G.703 (1988): "Physical/electrical characteristics of hierarchical digital interfaces".
- [4] CCITR Recommendation 696 (1992): "Error performance and availability objectives for hypothetical reference digital sections utilizing digital radio-relay systems forming part or all of the medium grade portion of an ISDN connection".
- [5] CCITR Recommendation 697 (1992): "Error performance and availability objectives for the local grade portion at each end of an ISDN connection utilizing digital radio-relay systems".
- [6] ITU-T Recommendation G.773 (1993): "Protocol suites for Q interfaces for management of transmission systems".
- [7] CCITT Recommendation G.821 (1988): "Error performance of a digital international connection".
- [8] ITU-T draft Recommendation G.826 (1993): "Error performance objectives for constant bit-rate digital paths".
- [9] prETS 300 385: "Radio Equipment and Systems (RES); EMC standard for digital fixed radio links and ancillary equipment with data rates at around 2 Mbit/s and above" (DE/RES-09008).
- [10] ITU-T Recommendation V.11 (1993): "Electrical characteristics for balanced double current interchange circuits operating at data signalling rates up to 10 Mbit/s".
- [11] CCITT Recommendation G.712 (1992): "Transmission Performance Characteristics of Pulse Code Modulation".
- [12] prETS 300 631: "Transmission and Multiplexing (TM); Radio relay equipment; Antennas for point-to-point and point-to-multipoint radio links in bands 1 to 3 GHz" (DE/TM-04018).
- [13] ITU-T Recommendation V.24 (1993): "List of definitions for interchange circuits between data terminal equipment (DTE) and data circuit-terminating equipment (DCE)".
- [14] ITU-T Recommendation G.784 (1994): "Synchronous Digital Hierarchy (SDH) management".
- [15] ETR 080 (1993): "Transmission and Multiplexing (TM); Integrated Services Digital Network (ISDN) basic rate access digital transmission system on local lines".
- [16] CCITR Recommendation G.746 ((1988): "Characteristics of second order PCM multiplex equipment operating at 6312 kbits/s".
- [17] CCITR Recommendation 634 (1992): "Error performance objectives for real digital radio relay links forming part of a high grade circuit within an integrated service digital network".

3 Abbreviations and symbols

3.1 Abbreviations

For the purpose of this ETS, the following abbreviations apply:

| | |
|-------|--|
| BB | Baseband |
| BER | Bit Error Ratio |
| CW | Continuous Wave |
| FEC | Forward Error Correction |
| IF | Intermediate Frequency |
| IF/RF | Intermediate Frequency/Radio Frequency |
| L.O | Local Oscillator |
| PRBS | Pseudo Random Binary Sequence |
| QAM | Quadrature Amplitude Modulation |
| RF | Radio Frequency |
| RSL | Receive Signal Level |
| RX | Receive |
| S/I | Signal to Interference Ratio |
| SRL | Spectrum Reference Level |
| TMN | Telecommunications Management Network |
| TX | Transmit |
| VSWR | Voltage Standing Wave Ratio |
| XPD | Cross-Polar Discrimination |
| W/U | Wanted to Unwanted Signal Ratio |

3.2 Symbols

For the purpose of this ETS the following symbols apply:

| | |
|--------|--------------------------|
| dB | decibel |
| dBm | decibel relative to 1 mW |
| GHz | Giga Hertz |
| km | kilometre |
| kbit/s | kilobit per second |
| Mbit/s | Megabit per second |
| MHz | Mega Hertz |
| ppm | parts per million |
| ns | nanosecond |

4 General characteristics

4.1 Frequency bands and channel arrangements

The systems are required to operate in the 2,1 and 2,6 GHz frequency bands as shown below in accordance with the CEPT Recommendation T/R 13-01 [1]:

- 2 025 to 2 110 MHz paired with 2 200 to 2 290 MHz;
- 2 520 to 2 593 MHz paired with 2 597 to 2 670 MHz.

and in the 2,3 to 2,5 GHz frequency band in accordance with the CCITR Recommendation 746 [16].

For each of the above bands all the GO channels should be in one half band with all the RETURN channels in the other.

4.2 Modes of operation

Depending on the application, it shall be possible to operate the system in vertical or horizontal polarisation. In the case of multiple channels on the same or parallel paths, alternate polarisations may be used such as specified by CCITR Recommendation 746 [16].

4.2.1 Channel spacing

Depending on the application, the following standard channel spacings may be used:

500 kHz, 1 MHz, 1,75 MHz, 2 MHz, 3,5 MHz, 7 MHz, 14 MHz.

4.2.2 Transmit / receive separation band

The transmit / receive separation band for the 2,1 GHz frequency band is 90 MHz.

4.2.3 Transmit / receive duplex frequency separation

The duplex frequency separation for the 2,1 GHz frequency band is 175 MHz.

The duplex frequency separation for the 2,6 GHz frequency band is 74 MHz.

The duplex frequency separation for the 2,3 to 2,5 GHz frequency band is 94 MHz.

4.3 Installation

4.3.1 Environmental conditions

The equipment shall be required to meet environmental conditions set out in ETS 300 019 [2] which defines weather protected and non weather protected locations classes and test severities.

4.3.1.1 Equipment within weather protected locations

Equipment intended for operation within temperature controlled locations or partially temperature controlled locations shall meet the requirements of ETS 300 019 [2] classes 3.1 and 3.2 respectively.

Optionally, the more stringent requirements of ETS 300 019 [2] classes 3.3 (Non temperature controlled locations), 3.4 (Sites with heat trap) and 3.5 (Sheltered locations) may be applied.

4.3.1.2 Equipment for non-weather protected locations

Equipment intended for operation within non weather protected locations shall meet the requirements of ETS 300 019 [2], class 4.1 or 4.1E.

Class 4.1 applies to many ETSI countries and class 4.1E applies to all ETSI countries.

For systems within radio cabinets giving full protection against precipitation, wind, etc. the ETS 300 019 [2] classes 3.3, 3.4 (a&d) and 3.5 may be applied also for equipment intended for operation in non-weather protected locations.

4.3.2 Electromagnetic compatibility conditions

Equipment operating at bit rates of 2 Mbit/s and above shall meet the requirements of the EMC standard: ETS 300 385 [9].

For lower bit rates, the subject is considered under study.

4.3.3 Power supply

The equipment shall operate from one or more of the primary supplies within the ranges specified in table 1.

Table 1: Power supplies - DC

| | |
|---------------------|--------------------|
| For 24 V DC nominal | -21,80 to -28,15 V |
| For 48 V DC nominal | -40,50 to -57,00 V |
| For 60 V DC nominal | -50,00 to -72,00 V |

For DC systems, the positive pole of the voltage supply will be earthed at the source.

It may be required to operate from a secondary supply within the ranges specified in table 2.

Table 2: Power supplies - AC

| | | |
|----------------------|--------------|------------------|
| For 110 V AC nominal | 99 to 121 V | 60 Hz \pm 2 Hz |
| For 230 V AC nominal | 207 to 253 V | 50 Hz \pm 2 Hz |

4.4 TMN Requirements

Telecommunications Management Network (TMN) interface, If any, should be in accordance with ITU-T Recommendations G. 784 [14] and G.773 [6].

4.5 Block Diagram

The system block diagram is shown in figure 1. The intersection points are for reference only and not necessarily measurement purposes, nor do they indicate a specific design structure.

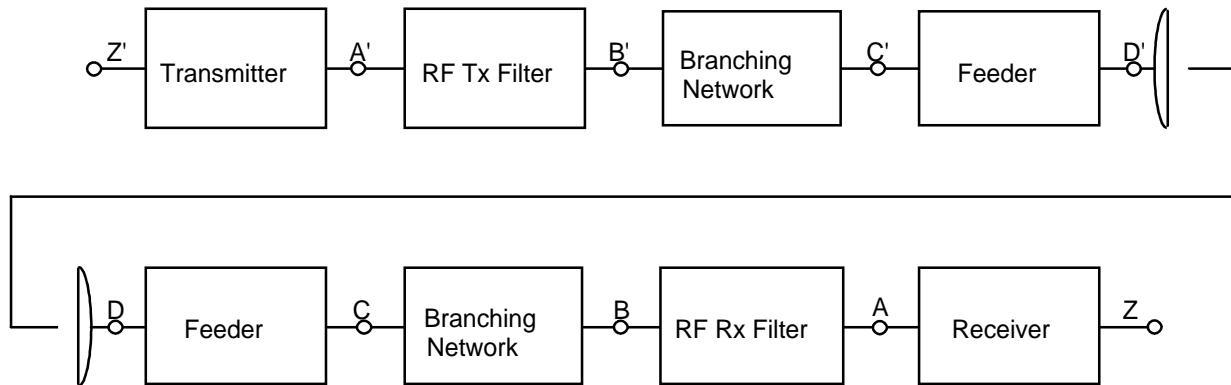

NOTE 1: For the purpose of defining the measurement points, the branching network does not include a hybrid.

NOTE 2: Points B and C, B' and C' may coincide.

Figure 1: System block diagram

4.6 Mechanical specifications for RF interfaces

Radio Frequency (RF) interfaces for antenna port at reference points C and C' (unless an integral antenna is used) shall be of 50 ohms coaxial.

5 Baseband characteristics

5.1 Plesiochronous Digital Hierarchy interfaces

Table 3 indicates relevant references for the ITU-T hierarchical baseband digital interfaces covered by this ETS.

Table 3: Baseband interfaces

| Bit rate | Interface |
|-------------------|---|
| 64 kbit/s | CCITT Recommendation G.703 [3], ITU-T Recommendation V.11 [10] |
| 2 / 8 / 34 Mbit/s | CCITT Recommendation G.703 [3] |

ISDN interface according to ETR 080 [15] may also be foreseen and other data rate interfaces are subject to customer requirement.

5.2 Analogue interfaces

Table 2b below indicates relevant references for the baseband analogue interfaces covered by this ETS.

Table 4: Analogue interfaces

| Nature | Interface |
|---------|---------------------------------|
| 2-wires | CCITT Recommendation G.712 [11] |
| 4-wires | CCITT Recommendation G.712 [11] |

Systems incorporating analogue interfaces, as primary service, shall provide digital test points (binary NRZ data + clock) at the transmitted bit rate (digital access of the input/output multiplexer) for system characteristics measurement purposes.

6 Transmitter characteristics

6.1 Output power

The maximum value of output power, referred to point C' shall not exceed +40 dBm.

If for regulatory purposes, a reduced range of output power is required, then an internal or external means of adjustment shall be provided.

The tolerance value around the nominal or selected value of output power is +2 / -1 dB.

6.2 RF spectrum masks

The spectrum masks relative to standard channel spacings and spectrum analyser settings for measurement purposes are shown in figure 2.

According to the channel spacing allocation, the equipment shall comply with the digital RF power spectrum mask given in figure 2. The 0 dB level shown on the spectrum masks relates to the spectral power density of the nominal centre frequency disregarding residual carrier. All spectrum masks include an allowance for frequency stability and accuracy, including ageing effects.

6.3 Spectral lines at the symbol rate

The power level of spectral lines at a distance from the channel centre frequency equal to the symbol rate shall be more than 35 dB below the transmitter output power level (reference point B').

6.4 Spurious emissions

For the purposes of this ETS the spurious emissions are defined as emissions at frequencies which are outside the nominal carrier frequency $\pm 2,5$ times the relevant channel spacing.

The frequency range in which the spurious emission specification is to apply is 30 MHz to 10 GHz. The limit values measured at point C' is: ≤ -60 dBm.

For the purposes of this ETS the measuring bandwidth is in the range 100 kHz to 120 kHz.

Within the exclusion bandwidth defined above the unwanted emission level shall not exceed the limits fixed by the relevant spectrum mask.

6.5 Radio frequency tolerance

Radio frequency tolerances are included in the spectrum masks given in figure 2. They include both tuning accuracy and environmental effects as well as long term ageing.

NOTE: For conformance testing purposes, the manufacturer should state the frequency tolerance to be taken into account for long term ageing and the mask reduced accordingly.

6.6 Return loss

The return loss measured towards the transmitter output port (point C') at the operating frequency shall not be less than 18 dB.

7 Receiver characteristics

7.1 Receiver image rejection

The receiver rejection at image frequencies which fall within the transmitter half band shall be:

| | |
|---------------|--------|
| Class 1 and 2 | 75 dB; |
| Class 3 | 85 dB. |

7.2 Receiver spurious emissions

The frequency range in which the spurious emission specification is to apply is 30 MHz to 10 GHz. The limit values measured at point C is: ≤ -60 dBm.

For the purpose of this ETS the measuring bandwidth is in the range 100 kHz to 120 kHz.

7.3 Input level range

The dynamic range of the receiver for a Bit Error ratio (BER) $< 10^{-3}$ shall extend for a minimum of 55 dB above the lower threshold for BER = 10^{-3} referenced to point C.

7.4 Return loss

The return loss measured towards the receiver input (point C) at the operating frequency shall not be less than 18 dB.

8 System characteristics

8.1 BER as a function of receiver input level

The reference point for the definition of the BER curve as a function of receiver input level is point C. The receive signal level for the relevant BER given in tables 5a, b and c shall not be exceeded (these levels do not include any hybrid loss).

Table 5a: Receiver sensitivity for Class 1 equipment

| Channel Spacing | BER 10⁻³ level (dBm) | BER 10⁻⁶ level (dBm) |
|------------------------|--|--|
| 500 kHz | -96 | -92 |
| 1 MHz | -93 | -89 |
| 1,75 MHz | -91 | -87 |
| 2 MHz | -90 | -86 |
| 3,5 MHz | -87 | -83 |

Table 5b: Receiver sensitivity for Class 2 equipment

| Channel Spacing | BER 10⁻³ level (dBm) | BER 10⁻⁶ level (dBm) |
|------------------------|--|--|
| 500 kHz | -99 | -95 |
| 1 MHz | -96 | -92 |
| 1,75 MHz | -94 | -90 |
| 2 MHz | -93 | -89 |
| 3,5 MHz | -90 | -86 |
| 7 MHz | -87 | -83 |
| 14 MHz | -84 | -80 |

Table 5c: Receiver sensitivity for Class 3 equipment

| Channel Spacing | BER 10⁻³ level (dBm) | BER 10⁻⁶ level (dBm) |
|------------------------|--|--|
| 500 kHz | -93 | -90 |
| 1 MHz | -90 | -86 |
| 1,75 MHz | -88 | -84 |
| 2 MHz | -87 | -83 |
| 3.5 MHz | -84 | -80 |
| 7 MHz | -81 | -77 |
| 14 MHz | -78 | -74 |

8.2 Equipment background BER

Equipment background BER (or residual BER) is measured under simulated operating conditions over an artificial hop without interference with a signal level at point C which is between 15 dB and 40 dB above the lower limit for receiver input level which gives BER = 10^{-3} . The measurement period shall not be less than 15 hours.

For measurements at system access rates between 64 kbit/s and 192 kbit/s:

- Background BER < 10^{-9} .

For measurements at system access rates above 192 kbit/s:

- Background BER < 10^{-10} .

NOTE: For the purpose of conformance testing, equipment with Forward Error Correction (FEC) facility may record decoder activity and estimate the BER through a conversion law stated by the manufacturer and tested at suitable higher BER points.

8.3 Interference sensitivity

The method to uniquely define equipment parameters to evaluate interference sensitivity between dissimilar equipment, e.g. capacity, modulation method etc. is subject to further study.

8.3.1.1 Method of testing like interferer W/U

For a receiver operating at the 10^{-6} BER threshold given in table 5a, b and c, the introduction of a like interferer at a level given in table 6, with respect to the wanted signal shall not result in a BER greater than 10^{-5} . Measurements shall be done with an interferer at the co-channel frequency and at the first and second adjacent channel frequencies.

8.3.1.2 Reference points

All receive signal levels and S/I measurements shall be referred to point B of the block diagram shown in figure 1.

8.3.2 Co-channel interference

The limits of the co-channel interference sensitivity shall be as given in table 6.

8.3.3 Adjacent channel interference

The limits of the adjacent channel interference sensitivity shall be as given in table 6.

Table 6: W/U conditions for co and adjacent channel interferences tests

| | Channel spacing | Co-channel | Adjacent channel | |
|---|-----------------|------------|------------------|--------|
| | | 0 | 1 | ≥ 2 |
| Frequency separation | 500 kHz | 0 kHz | 500 kHz | 1 MHz |
| | 1 MHz | 0 kHz | 1 MHz | 2 MHz |
| | 1,75 MHz | 0 kHz | 1,75 MHz | 3 MHz |
| | 2 MHz | 0 kHz | 2 MHz | 4 MHz |
| | 3,5 MHz | 0 kHz | 3,5 MHz | 7 MHz |
| | 7 MHz | 0 kHz | 7 MHz | 14 MHz |
| | 14 MHz | 0 kHz | 14 MHz | 28 MHz |
| W/U ratio (dB) | Class 1 & 2 | 23 dB | 0 dB | -25 dB |
| | Class 3 | 30 dB | 0 dB | -25 dB |
| NOTE: These values do not include any cross-polar discrimination improvement. | | | | |

8.3.4 CW spurious interference

The Continuous Wave (CW) spurious response rejection ratio of a receiver is a measure of its ability to discriminate between the wanted signal at the nominal channel frequency of the receiver and an unwanted signal at any other frequency at which a response is obtained.

For a receiver operating at the 10^{-6} BER threshold given in table 6, the introduction of a CW interferer at a level of + 30 dB, with respect to the "wanted" signal and at any frequency in the range 30 MHz to 10 GHz, excluding frequencies either side of the wanted frequency by up to twice the co-polarisation channel spacing, shall not result in a BER greater than 10^{-5} .

This test is not intended to imply a relaxed specification at all out of band frequencies.

9 Feeder / antenna requirements

The parameters and values are specified in ETS 300 631 [12].

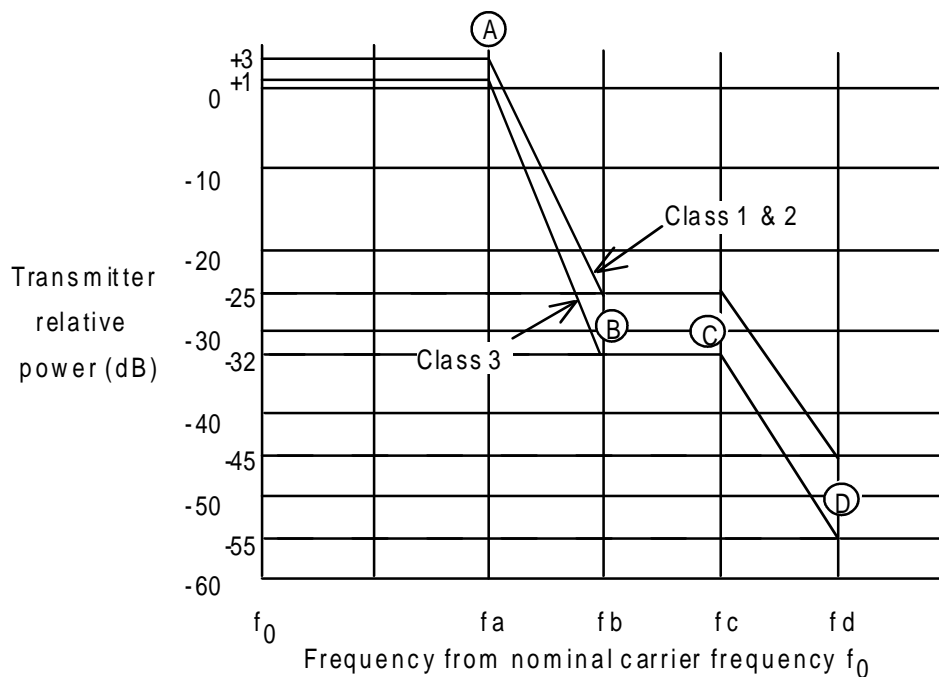

| Channel Spacing | f_a | f_b | f_c | f_d |
|-----------------|-----------|-----------|------------|------------|
| 500 kHz | 210 kHz | 325 kHz | 450 kHz | 800 kHz |
| 1 MHz | 420 kHz | 650 kHz | 900 kHz | 1 600 kHz |
| 1,75 MHz | 750 kHz | 1 150 kHz | 1 600 kHz | 2 800 kHz |
| 2 MHz | 840 kHz | 1 300 kHz | 1 800 kHz | 3 200 kHz |
| 3,5 MHz | 1 500 kHz | 2 400 kHz | 3 500 kHz | 6 000 kHz |
| 7 MHz | 3 000 kHz | 4 800 kHz | 7 000 kHz | 12 000 kHz |
| 14 MHz | 6 000 kHz | 9 600 kHz | 14 000 kHz | 24 000 kHz |

Figure 2: Limits of spectral power density as a function of channel spacing

This mask refers to nominal centre frequency and includes an allowance for frequency stability.

Table 7: Spectrum analyser settings

| Parameter | Settings | | | | | | |
|-----------------------------|----------|------|------|------|------|------|------|
| Channel spacing (MHz) | 0,5 | 1 | 1,75 | 2 | 3,5 | 7 | 14 |
| RF centre frequency | fo | fo | fo | fo | fo | fo | fo |
| Amplitude scale (dB/div) | 10 | 10 | 10 | 10 | 10 | 10 | 10 |
| IF bandwidth (KHz) | 3 | 10 | 10 | 30 | 30 | 30 | 100 |
| Sweep width (MHz) | 2 | 5 | 10 | 10 | 20 | 40 | 80 |
| Scan time | Auto | Auto | Auto | Auto | Auto | Auto | Auto |
| Video bandwidth filter (Hz) | 100 | 100 | 100 | 300 | 300 | 300 | 1000 |

Annex A (informative): Indicative channel capacities

Indicative channel capacities (gross bit rate) for the three classes of equipment based on the maximum gross bit rate for the minimum modulation level of each Class. It is possible to improve on the gross bit rate by using higher modulation schemes within each Class. The use of higher modulation levels within each class is permitted so long as the limits of the relevant spectral power density mask are not exceeded.

Table A.1: Indicative channel capacities (gross bit rate) for each equipment Class

| Channel spacing | Class 1 | Class 2 | Class 3 |
|------------------------|----------------|----------------|----------------|
| 500 kHz | 400 kbit/s | 650 kbit/s | 1300 kbit/s |
| 1 MHz | 800 kbit/s | 1 300 kbit/s | 2 600 kbit/s |
| 1,75 MHz | 1 400 kbit/s | 2 275 kbit/s | 4 550 kbit/s |
| 2 MHz | 1 600 kbit/s | 2 600 kbit/s | 5 200 kbit/s |
| 3,5 MHz | 2 800 kbit/s | 4 500 kbit/s | 9 100 kbit/s |
| 7 MHz | Not applicable | 9 000 kbit/s | 18 200 kbit/s |
| 14 MHz | Not applicable | 18 000 kbit/s | 38 000 kbit/s |

History

| Document history | |
|------------------|---|
| July 1995 | Public Enquiry PE 88: 1995-07-24 to 1995-11-17 |
| May 1996 | Converted into Adobe Acrobat Portable Document Format (PDF) |
| | |
| | |
| | |