



EUROPEAN
TELECOMMUNICATION
STANDARD

FINAL DRAFT
pr **ETS 300 630**

December 1996

Source: ETSI TC-TM

Reference: DE/TM-04014

ICS: 33.020

Key words: DRRS, radio, relay, transmission, point-to-point

**Transmission and Multiplexing (TM);
Low capacity point-to-point Digital Radio Relay Systems (DRRS)
operating in the 1,4 GHz frequency band**

ETSI

European Telecommunications Standards Institute

ETSI Secretariat

Postal address: F-06921 Sophia Antipolis CEDEX - FRANCE

Office address: 650 Route des Lucioles - Sophia Antipolis - Valbonne - FRANCE

X.400: c=fr, a=atlas, p=etsi, s=secretariat - **Internet:** secretariat@etsi.fr

Tel.: +33 4 92 94 42 00 - Fax: +33 4 93 65 47 16

Copyright Notification: No part may be reproduced except as authorized by written permission. The copyright and the foregoing restriction extend to reproduction in all media.

© European Telecommunications Standards Institute 1996. All rights reserved.

Contents

| | | |
|---------|---|----|
| 1 | Scope | 7 |
| 2 | Normative references | 8 |
| 3 | Abbreviations and symbols | 9 |
| 3.1 | Abbreviations | 9 |
| 3.2 | Symbols | 9 |
| 4 | General characteristics | 10 |
| 4.1 | Frequency bands and channels arrangements | 10 |
| 4.2 | Modes of operation | 10 |
| 4.2.1 | Channel spacing..... | 10 |
| 4.2.2 | Transmit/receive duplex frequency separation | 10 |
| 4.3 | Installation..... | 10 |
| 4.3.1 | Environmental conditions | 10 |
| 4.3.1.1 | Equipment within weather protected locations | 10 |
| 4.3.1.2 | Equipment for non-weather protected locations | 10 |
| 4.3.2 | Electromagnetic compatibility conditions..... | 10 |
| 4.3.3 | Power supply | 11 |
| 4.4 | TMN requirements | 11 |
| 4.5 | Block diagram | 11 |
| 4.6 | RF interfaces | 12 |
| 5 | Baseband characteristics | 12 |
| 5.1 | Plesiochronous Digital Hierarchy (PDH) interfaces | 12 |
| 5.2 | Analogue interfaces | 12 |
| 6 | Transmitter characteristics | 12 |
| 6.1 | Output power | 12 |
| 6.2 | RF spectrum masks..... | 13 |
| 6.3 | Spectral lines at the symbol rate..... | 14 |
| 6.4 | Spurious emissions..... | 14 |
| 6.5 | Radio frequency tolerance | 14 |
| 6.6 | Return loss..... | 14 |
| 7 | Receiver characteristics | 15 |
| 7.1 | Receiver image rejection(s) | 15 |
| 7.2 | Receiver spurious emissions | 15 |
| 7.3 | Input level range | 15 |
| 7.4 | Return loss..... | 15 |
| 8 | System characteristics | 15 |
| 8.1 | BER as a function of receiver input level | 15 |
| 8.2 | Equipment background BER | 16 |
| 8.3 | Interference sensitivity | 16 |
| 8.3.1 | Co-channel interference..... | 16 |
| 8.3.2 | Adjacent channel interference..... | 16 |
| 8.3.3 | CW Spurious interference | 17 |
| 9 | Feeder/antenna requirements..... | 17 |
| | Annex A (informative): Indicative channel capacities..... | 18 |
| | History..... | 19 |

Blank page

Foreword

This final draft European Telecommunication Standard (ETS) has been prepared by the Transmission and Multiplexing (TM) Technical Committee of the European Telecommunications Standards Institute (ETSI) and is now submitted for the Voting phase of the ETSI standards approval procedure.

| Proposed transposition dates | |
|---|---------------------------------|
| Date of latest announcement of this ETS (doa): | 3 months after ETSI publication |
| Date of latest publication of new National Standard or endorsement of this ETS (dop/e): | 6 months after doa |
| Date of withdrawal of any conflicting National Standard (dow): | 6 months after doa |

Blank page

1 Scope

This ETS specifies the minimum performance parameters for terrestrial digital fixed service radio communications equipment operating in the 1,4 GHz frequency bands. The requirements and limits given in this ETS are relevant to all environmental conditions for the chosen climatic class. The test methods to be used are currently under study in ETSI STC TM4.

Digital systems are intended to be used for point-to-point connections in local and regional networks at data rates between 9,6 kbit/s and 4x2 Mbit/s. Other data rates may also be foreseen. Typical applications include:

- a) customer connections;
- b) Integrated Services Digital Network (ISDN) extension;
- c) mobile base station connections;
- d) telemetry and telecontrol, including transportable and off-shore use.

CCIR high, medium and local grade performance objectives, i.e. CCIR Recommendations F.634 [14], F.696 [4], F.697 [5], CCITT Recommendation G.821 [7] and the forthcoming performance objectives detailed in ITU-T Recommendation G.826 [8] should be realizable using systems considered in this ETS.

The parameters to be specified fall into two categories:

- a) Those that are required to provide compatibility between channels from different sources of equipment on the same route, connected either to:
 - separate antennas; or to
 - separate polarizations of the same antenna.
- b) Parameters defining the transmission quality of the proposed system.

The ETS deals with Intermediate Frequency (IF), Radio Frequency (RF) and baseband characteristics relevant to low capacity Plesiochronous Digital Hierarchy (PDH) transmission. Antenna/feeder system requirements are covered in ETS 300 631 [12].

Due to the wide spread of applications and corresponding system rates, parameters such as RF spectrum masks and receiver sensitivity are related to standardized channel spacings rather than to minimum system rates. This allows individual countries to allocate a bandwidth and therefore a standard channel spacing in accordance with the foreseen services and their own frequency management and radio network planning.

As the maximum bit rate in a given bandwidth depends on the system spectral efficiency, different equipment classes are defined:

- Class 1: equipment based on a minimum of 2-level modulation scheme (e.g. 2-FSK, GMSK with discriminator detection, or equivalent);
- Class 2: equipment based on a minimum 4-level modulation scheme (e.g. 4-FSK, 4-QAM, or equivalent);
- Class 3: equipment based on a minimum 16-level modulation scheme (e.g. 16-QAM, or equivalent).

Safety aspects are outside the mandate of ETSI and they will not be considered in this ETS.

2 Normative references

This ETS incorporates, by dated or undated reference, provisions from other publications. These normative references are cited at the appropriate place in the text and the publications are listed hereafter. For dated references, subsequent amendments to, or revisions of, any of these publications apply to this ETS only when incorporated in it by amendment or revision. For undated references, the latest edition of the publication referred to applies.

- [1] CEPT Recommendation T/R 13-01: "Preferred channel arrangements for fixed services in the range 1 - 3 GHz".
- [2] ETS 300 019 Parts 1 and 2 (1994): "Equipment Engineering (EE); Environmental conditions and environmental tests for telecommunications equipment Part 1-1 to 1-7: Classification of environmental conditions, Part 2-1 to 2-7: Specification of environmental tests".
- [3] CCITT Recommendation G.703 (1988): "Physical/electrical characteristics of hierarchical digital interfaces".
- [4] CCIR Recommendation F.696 (1992): "Error performance and availability objectives for hypothetical reference digital sections utilizing digital radio-relay systems forming part or all of the medium grade portion of an ISDN connection".
- [5] CCIR Recommendation F.697 (1992): "Error performance and availability objectives for the local grade portion at each end of an ISDN connection utilizing digital radio-relay systems".
- [6] ITU-T Recommendation G.773 (1993): "Protocol suites for Q interfaces for management of transmission systems".
- [7] CCITT Recommendation G.821 (1988): "Error performance of a digital international connection".
- [8] ITU-T draft Recommendation G.826 (1993): "Error performance objectives for constant bit-rate digital paths".
- [9] ETS 300 385: "Radio Equipment and Systems (RES); EMC standard for digital fixed radio links and ancillary equipment with data rates at around 2 Mbit/s and above".
- [10] ITU-T Recommendation V.11 (1993): "Electrical characteristics for balanced double current interchange circuits operating at data signalling rates up to 10 Mbit/s".
- [11] CCITT Recommendation G.712 (1992): "Transmission Performance Characteristics of Pulse Code Modulation".
- [12] prETS 300 631: "Transmission and Multiplexing (TM); Radio relay equipment; Antennas for point-to-point radio links in bands 1 to 3 GHz Essential requirements on electrical characteristics".
- [13] ITU-T Recommendation V.24 (1993): "List of definitions for interchange circuits between data terminal equipment (DTE) and data circuit-terminating equipment (DCE)".
- [14] CCIR Recommendation F.634 (1992): "Error performance objectives for real digital radio-relay links forming part of a high grade circuit within an ISDN network".
- [15] ETS 300 132 Parts 1 and 2: "Equipment Engineering (EE); Power supply interface at the input to telecommunications equipment interface".

- [16] ETR 080: "Transmission and Multiplexing (TM); Integrated Services Digital Network (ISDN) basic rate access; Digital transmission system on metallic local lines".
- [17] ITU-T Recommendation I.430 (1993): "Basic user-network interface - Layer 1 specification".
- [18] CCITT Recommendation X.21 (1992): "Interface between data terminal equipment and data circuit-terminating equipment for synchronous operation on public data networks".
- [19] prETS 300 339: "Radio Equipment and Systems (RES); General Electro-Magnetic Compatibility (EMC) for radio equipment".

3 Abbreviations and symbols

3.1 Abbreviations

For the purposes of this ETS, the following abbreviations apply:

| | |
|-------|---|
| AC | Alternating Current |
| BER | Bit Error Ratio |
| CEPT | Conférence des Administrations Européennes des Postes et Télécommunications |
| CW | Continuous Wave |
| DC | Direct Current |
| EMC | ElectroMagnetic Compatibility |
| FSK | Frequency Shift Keying |
| GMSK | Gaussian Minimum Shift Keying |
| IF | Intermediate Frequency |
| IF/RF | Intermediate Frequency/Radio Frequency |
| ISDN | Integrated Services Digital Network |
| NRZ | Non return to Zero |
| PDH | Plesiochronous Digital Hierarchy |
| QAM | Quadrature Amplitude Modulation |
| RF | Radio Frequency |
| RX | Receiver |
| S/I | Signal to Interference ratio |
| TMN | Telecommunications Management Network |
| TX | Transmitter |
| W/U | Wanted to Unwanted signal ratio |

3.2 Symbols

For the purposes of this ETS, the following symbols apply:

| | |
|--------|--------------------------|
| dB | decibel |
| dBm | decibel relative to 1 mW |
| GHz | gigahertz |
| kHz | kilohertz |
| Hz | Hertz |
| kbit/s | kilobits per second |
| Mbit/s | megabits per second |
| MHz | megahertz |

4 General characteristics

4.1 Frequency bands and channels arrangements

The systems are required to operate in the 1,4 GHz frequency bands as shown below, in accordance with the CEPT Recommendation T/R 13-01 [1]:

- 1 350 MHz to 1 375 MHz paired with 1 492 MHz to 1 517 MHz;
- 1 375 MHz to 1 400 MHz paired with 1 427 MHz to 1 452 MHz.

The channel plan is based on a 0,5 MHz homogenous channel pattern using vertical and horizontal polarizations. The equipment shall be capable of operating to the channel plans given in the CEPT Recommendation T/R 13-01 [1].

4.2 Modes of operation

Depending on the application, it shall be possible to operate the system in vertical, horizontal, or in the case of multiple parallel paths or channels, alternate polarizations.

4.2.1 Channel spacing

Depending on the application, the following standard channel spacings may be used:

25 kHz, 75 kHz, 250 kHz, 500 kHz, 1 MHz, 2 MHz, 3,5 MHz.

4.2.2 Transmit/receive duplex frequency separation

For the frequency band 1 350 MHz to 1 375 MHz paired with 1 492 MHz to 1 517 MHz, the transmitter to receiver duplex frequency separation is 142 MHz.

For the frequency band 1 375 MHz to 1 400 MHz paired with 1 427 MHz to 1 452 MHz, the transmitter to receiver duplex frequency separation is 52 MHz.

4.3 Installation

4.3.1 Environmental conditions

The equipment shall be required to meet environmental conditions set out in ETS 300 019 [2] which defines weather protected and non weather protected locations classes and test severities.

4.3.1.1 Equipment within weather protected locations

Equipment intended for operation within temperature controlled locations or partially temperature controlled locations shall meet the requirements of ETS 300 019 [2] classes 3.1 and 3.2 respectively.

Optionally, the more stringent requirements of ETS 300 019 [2] classes 3.3 (non temperature controlled locations), 3.4 (sites with heat trap) and 3.5 (sheltered locations) may be applied.

4.3.1.2 Equipment for non-weather protected locations

Equipment intended for operation within non weather protected locations shall meet the requirements of ETS 300 019 [2], class 4.1 or 4.1E.

Class 4.1 applies to many ETSI countries and class 4.1E applies to all ETSI countries.

Weather protected equipment together with an enclosure or cabinet may fulfill the requirements for operating in a non weather protected environment but this is outside the scope of this ETS.

4.3.2 Electromagnetic compatibility conditions

Equipment operating at bit rates of 2 Mbit/s and above shall meet the requirements of the EMC standard: ETS 300 385 [9].

For lower capacities the subject is under study, however ETS 300 339 [19] shall apply.

4.3.3 Power supply

The equipment shall operate from one or more of the power supplies detailed in ETS 300-132 parts 1 and 2 [15] shown in table 1.

Table 1: Power supplies covered by ETS 300-132 parts 1 and 2

| | | |
|-----------------------------|-------------------------------|------------------|
| For 230 V AC nominal | 207 V to 253 V (see part 1) | 50 Hz \pm 2 Hz |
| For 48 V DC nominal | -40,5 V to -57 V (see part 2) | - |
| For 60 V DC nominal | -50,0 V to -72 V (see part 2) | - |

For DC systems, the positive pole of the voltage supply will be earthed at the source.

It may be required to operate from power supplies within the ranges specified in table 2 which are not detailed in ETS 300-132 parts 1 and 2 [15].

Table 2: Power supplies not included in ETS 300-132 parts 1 and 2

| | | |
|-----------------------------|---------------------|------------------|
| For 110 V AC nominal | 99 V to 121 V | 60 Hz \pm 2 Hz |
| For 24 V DC nominal | -21,8 V to -28,15 V | 50 Hz \pm 2 Hz |

4.4 TMN requirements

The Telecommunications Management Network (TMN) interface, if any, should be in accordance with ITU-T Recommendation G.773 [6].

4.5 Block diagram

The system block diagram is shown in figure 1. The intersection points are for reference only and not necessarily measurement purposes, nor do they indicate a specific design structure.

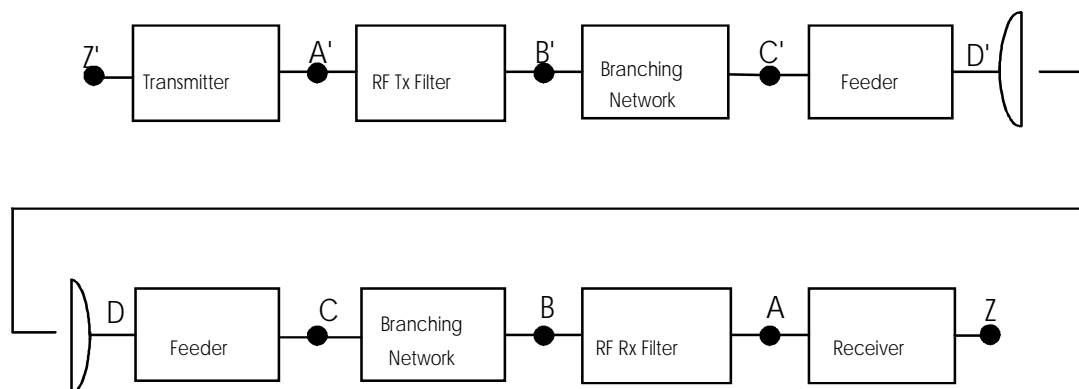

NOTE 1: For the purpose of defining the measurement points, the branching network does not include a hybrid.

NOTE 2: Points B and C, B' and C' may coincide.

Figure 1: System block diagram

4.6 RF interfaces

RF interfaces for antenna port at reference points C and C' (unless an integral antenna is used) shall be of 50 Ω coaxial. Standard IEC connectors shall be used.

5 Baseband characteristics

5.1 Plesiochronous Digital Hierarchy (PDH) interfaces

Table 3 below indicates relevant references for the ITU-T hierarchical baseband digital interfaces covered by this ETS.

Table 3: Baseband interfaces

| Bit rate | Electrical characteristics of interface |
|------------------------------|--|
| 9,6 kbit/s | ITU-T Recommendation V.24 [13] |
| 64 kbit/s | CCITT Recommendation G.703 [3] and/or ITU-T Recommendation V.11 [10] |
| 192 kbit/s | T interface of ITU-T Recommendation I.430 [17] |
| ISDN Local Access (see note) | ETR 080 [16] |
| 704 kbit/s | CCITT Recommendation X.21 [18] and/or ITU-T Recommendation V.11 [10] and/or HDB3 code (described in CCITT Recommendation G.703 [3]) |
| 2 Mbit/s | CCITT Recommendation G.703 [3] |
| NOTE: | ETR 080 [16] defines two ISDN basic rate access for digital transmission systems on metallic local lines: the first one at 80 kbaud uses 4-level 2B1Q coding, the second at 120 kbaud, uses ternary 4B3T coding. Other data rate interfaces are subject to customer requirement. |

NOTE: Any other ITU-T standardized bit rate between 9,6 kbit/s and 2 Mbit/s is applicable.

5.2 Analogue interfaces

Table 4 below indicates relevant references for the baseband analogue interfaces covered by this ETS.

Table 4: Analogue interfaces

| Nature | Electrical characteristics of interface |
|---------|---|
| 2-wires | CCITT Recommendation G.712 [11] |
| 4-wires | CCITT Recommendation G.712 [11] |

Systems incorporating analogue interfaces, as primary service, shall provide digital test points (binary NRZ data + clock) at the transmitted bit rate (digital access of the input/output multiplexer) for system characteristics measurement purposes.

6 Transmitter characteristics

6.1 Output power

The maximum value of output power, referred to point C' shall not exceed +40 dBm.

If for regulatory purposes, a reduced range of output power is required, then an internal or external means of adjustment shall be provided.

The tolerance value around the nominal or selected value of output power is +2 dB/-1 dB.

6.2 RF spectrum masks

The spectrum masks relative to standard channel spacings and spectrum analyzer settings for measurement purposes are shown in figure 2 and in table 5 respectively.

According to the channel spacing allocation, the equipment shall comply with the digital RF power spectrum mask given in figure 2. The 0 dB level shown on the spectrum masks relates to the spectral power density of the nominal centre frequency disregarding residual carrier. All spectrum masks include an allowance for frequency stability and accuracy, including ageing effects.

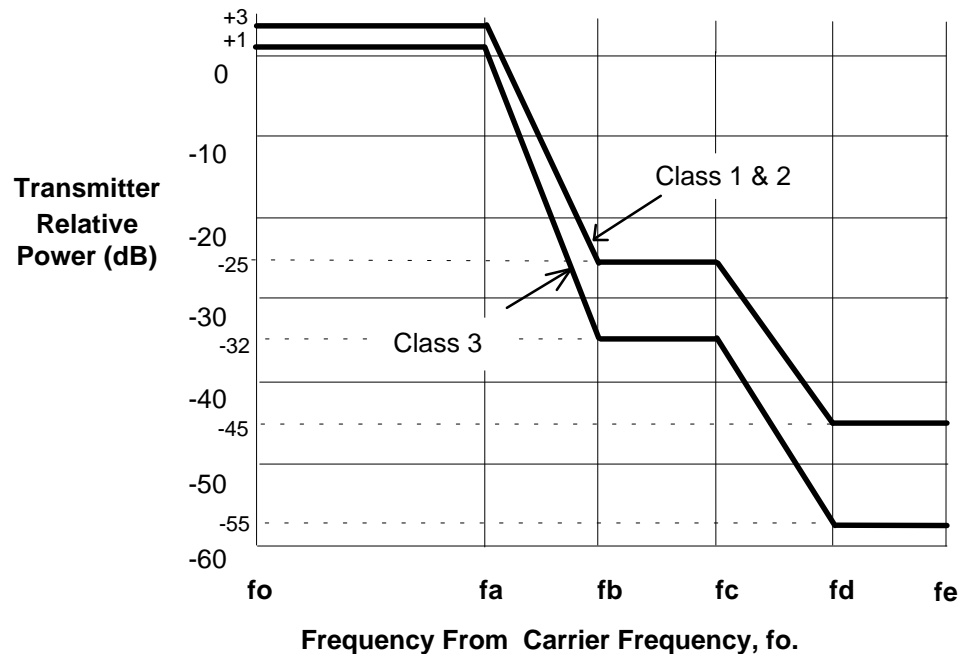

| Channel Spacing | fa | fb | fc | fd | fe |
|-----------------|-----------|-----------|-----------|-----------|-----------|
| 25 kHz | 12 kHz | 18 kHz | 25 kHz | 40 kHz | 62,5 kHz |
| 75 kHz | 36 kHz | 54 kHz | 75 kHz | 120 kHz | 187,5 kHz |
| 250 kHz | 110 kHz | 170 kHz | 230 kHz | 400 kHz | 625 kHz |
| 500 kHz | 210 kHz | 325 kHz | 450 kHz | 800 kHz | 1,25 MHz |
| 1 MHz | 420 kHz | 650 kHz | 900 kHz | 1 600 kHz | 2,5 MHz |
| 2 MHz | 840 kHz | 1 300 kHz | 1 800 kHz | 3 200 kHz | 5,0 MHz |
| 3,5 MHz | 1 500 kHz | 2 400 kHz | 3 500 kHz | 6 000 kHz | 8,75 MHz |

NOTE: This mask refers to nominal centre frequency and includes an allowance for frequency stability.

Figure 2: Limits of spectral power density as a function of channel spacing

Table 5: Spectrum analyzer settings

| Parameter | Settings | | | | | | |
|-----------------------------|----------|---------|---------|---------|--------|--------|---------|
| | 25 kHz | 75 kHz | 250 kHz | 500 kHz | 1 MHz | 2 MHz | 3,5 MHz |
| Channel spacing | fo | fo | fo | fo | fo | fo | fo |
| RF centre frequency | fo | fo | fo | fo | fo | fo | fo |
| Amplitude scale (dB/div) | 10 | 10 | 10 | 10 | 10 | 10 | 10 |
| IF bandwidth | 0,3 kHz | 1 kHz | 3 kHz | 3 kHz | 10 kHz | 30 kHz | 30 kHz |
| Sweep width | 200 kHz | 500 kHz | 2 MHz | 3 MHz | 10 MHz | 15 MHz | 20 MHz |
| Scan time | Auto | Auto | Auto | Auto | Auto | Auto | Auto |
| Video bandwidth filter (Hz) | 30 | 30 | 100 | 100 | 100 | 300 | 300 |

6.3 Spectral lines at the symbol rate

The power level of spectral lines at a distance from the channel centre frequency equal to the symbol rate shall be more than 35 dB below the transmitter output power level (reference point B').

6.4 Spurious emissions

For the purposes of this ETS the spurious emissions are defined as emissions at frequencies which are outside the nominal carrier frequency $\pm 2,5$ times the relevant channel spacing.

The frequency range in which the spurious emission specification is to apply is 30 MHz to 10 GHz. The values measured at point C' shall be ≤ -60 dBm.

This is a provisional limit subject to consultation with CEPT and other relevant parties.

For the purposes of this ETS the measuring bandwidth is in the range 100 kHz to 120 kHz, except for equipment occupying a channel spacing of less than 250 kHz where the measuring bandwidth shall be reduced to 3 kHz within ± 1 MHz of the nominal carrier frequency.

Within the exclusion bandwidth defined above the unwanted emission level shall not exceed the limits fixed by the relevant spectrum mask.

6.5 Radio frequency tolerance

Radio frequency tolerances are included in the spectrum masks given in figure 2. They include both tuning accuracy and environmental effects as well as long term ageing.

NOTE: For conformance testing purposes, the manufacturer should state the frequency tolerance to be taken into account for long term ageing and the mask reduced accordingly.

6.6 Return loss

The return loss measured towards the transmitter output port (point C') at the operating frequency shall not be less than 15 dB.

7 Receiver characteristics

7.1 Receiver image rejection(s)

The definition of a receiver image rejection is not applicable to receivers with direct demodulation.

If applicable the receiver image rejection shall be:

| | |
|---------------|----------------|
| Class 1 and 2 | 75 dB minimum; |
| Class 3 | 85 dB minimum. |

7.2 Receiver spurious emissions

The frequency range in which the spurious emission specification is to apply is 30 MHz to 10 GHz. The values measured at point C shall be ≤ -60 dBm. This is a provisional limit subject to consultation with CEPT and other relevant parties. For the purposes of this ETS the measuring bandwidth is in the range 100 kHz to 120 kHz, except for equipment occupying a channel spacing of less than 250 kHz where the measuring bandwidth shall be reduced to 3 kHz within ± 1 MHz of the nominal carrier frequency.

7.3 Input level range

The dynamic range of the receiver for a BER $< 10^{-3}$ shall extend for a minimum of 55 dB above the lower threshold for BER = 10^{-3} referenced to point C.

7.4 Return loss

The return loss measured towards the receiver input (point C) at the operating frequency shall not be less than 15 dB.

8 System characteristics

8.1 BER as a function of receiver input level

The reference point for the definition of the BER curve as a function of receiver input level is point C. The receive signal level for the relevant BER given in tables 6a, b and c shall not be exceeded (these levels do not include any hybrid loss).

Table 6a: Receiver sensitivity for Class 1 equipment

| Channel Spacing | BER 10^{-3} level (dBm) | BER 10^{-6} level (dBm) |
|-----------------|---------------------------|---------------------------|
| 25 kHz | -109 | -105 |
| 75 kHz | -104 | -100 |
| 250 kHz | -98 | -94 |
| 500 kHz | -96 | -92 |
| 1 MHz | -93 | -89 |
| 2 MHz | -90 | -86 |
| 3,5 MHz | -87 | -83 |

Table 6b: Receiver sensitivity for Class 2 equipment

| Channel Spacing | BER 10⁻³ level (dBm) | BER 10⁻⁶ level (dBm) |
|------------------------|--|--|
| 25 kHz | -112 | -108 |
| 75 kHz | -107 | -103 |
| 250 kHz | -101 | -97 |
| 500 kHz | -99 | -95 |
| 1 MHz | -96 | -92 |
| 2 MHz | -93 | -89 |
| 3,5 MHz | -90 | -86 |

Table 6c: Receiver sensitivity for Class 3 equipment

| Channel Spacing | BER 10⁻³ level (dBm) | BER 10⁻⁶ level (dBm) |
|------------------------|--|--|
| 25 kHz | -105 | -101 |
| 75 kHz | -101 | -97 |
| 250 kHz | -95 | -91 |
| 500 kHz | -93 | -89 |
| 1 MHz | -90 | -86 |
| 2 MHz | -87 | -83 |
| 3,5 MHz | -84 | -80 |

8.2 Equipment background BER

The equipment background BER under simulated operating conditions without interference is measured with a signal level at point C which is 10dB above the level which gives BER = 10⁻⁶. The measurement period shall not be less than 15 hours.

For measurements at system access rates up to 192 kbit/s: residual BER < 10⁻⁹.

For all other system access rates: residual BER < 10⁻¹⁰.

8.3 Interference sensitivity

The method to uniquely define equipment parameters to evaluate interference sensitivity between dissimilar equipment, e.g. capacity, modulation method etc. is subject to further study.

Method of testing like interferer Wanted to Unwanted (W/U) signal ratio

For a receiver operating at the 10⁻⁶ BER threshold given in tables 6a, b and c, the introduction of a like interferer at a level given in table 7, with respect to the wanted signal shall not result in a BER greater than 10⁻⁵. Measurements shall be done with an interferer at the co-channel frequency and at the first and second adjacent channel frequencies.

Reference points

All receive signal levels and Signal to Interference Ratio (S/I) measurements shall be referred to point B of the block diagram shown in figure 1.

8.3.1 Co-channel interference

The limits of the co-channel interference sensitivity shall be as given in table 7.

8.3.2 Adjacent channel interference

The limits of the adjacent channel interference sensitivity shall be as given in table 7.

Table 7: W/U conditions for co and adjacent channel interferences tests

| | Channel Spacing | Co-Channel | Adjacent | Channel |
|---|-----------------|------------|----------|---------|
| | | 0 | 1 | ≥ 2 |
| Frequency separation | 25 kHz | 0 kHz | 25 kHz | 50 kHz |
| | 75 kHz | 0 kHz | 75 kHz | 150 kHz |
| | 250 kHz | 0 kHz | 250 kHz | 500 kHz |
| | 500 kHz | 0 kHz | 500 kHz | 1 MHz |
| | 1 MHz | 0 kHz | 1 MHz | 2 MHz |
| | 2 MHz | 0 kHz | 2 MHz | 4 MHz |
| | 3,5 MHz | 0 kHz | 3,5 MHz | 7 MHz |
| W/U Ratio (dB) | Class 1 & 2 | 23 dB | 0 dB | -25 dB |
| | Class 3 | 30 dB | 0 dB | -25 dB |
| NOTE: These values do not include any cross-polar discrimination improvement. | | | | |

8.3.3 CW Spurious interference

The CW spurious response rejection ratio of a receiver is a measure of its ability to discriminate between the wanted signal at the nominal channel frequency of the receiver and an unwanted signal at any other frequency at which a response is obtained.

For a receiver operating at the 10^{-6} BER threshold given in table 6a, 6b, 6c, the introduction of a CW interferer at a level of +30 dB, with respect to the wanted signal and at any frequency in the range 30 MHz to 10 GHz, excluding frequencies either side of the wanted frequency by up to twice the co-polar channel spacing, shall not result in a BER greater than 10^{-5} .

This test is designed to identify specific frequencies at which the receiver may have a spurious response, for example, image frequency, harmonics of the receive filter, etc. The actual test range should be adjusted accordingly. The test is not intended to imply a relaxed specification at all out of band frequencies specified elsewhere in this ETS.

9 Feeder/antenna requirements

The parameters and values are specified in ETS 300 631 [12].

Annex A (informative): Indicative channel capacities

The indicative channel capacities (gross bit rate) for the three classes of equipment are based on the maximum gross bit rate for the minimum modulation level in each class. It is possible to improve on the gross bit rate by using higher modulation schemes within each class. The use of higher modulation levels within each class is permitted so long as the limits of the relevant spectral power density mask are not exceeded.

Table A.1: Indicative channel capacities (gross bit rate) for each equipment class

| Channel | Class 1 equipment | Class 2 equipment | Class 3 equipment |
|----------------|--------------------------|--------------------------|--------------------------|
| 25 kHz | 20 kbit/s | 32 kbit/s | 64 kbit/s |
| 75 kHz | 60 kbit/s | 95 kbit/s | 190 kbit/s |
| 250 kHz | 200 kbit/s | 325 kbit/s | 650 kbit/s |
| 500 kHz | 400 kbit/s | 650 kbit/s | 1 300 kbit/s |
| 1 MHz | 800 kbit/s | 1 300 kbit/s | 2 600 kbit/s |
| 2 MHz | 1 600 kbit/s | 2 600 kbit/s | 5 200 kbit/s |
| 3,5 MHz | 2 800 kbit/s | 4 500 kbit/s | 9 100 kbit/s |

History

| Document history | | | |
|-------------------------|----------------|--------|--------------------------|
| July 1995 | Public Enquiry | PE 88: | 1995-07-24 to 1995-11-17 |
| December 1996 | Vote | V 117: | 1996-12-23 to 1997-02-14 |
| | | | |
| | | | |
| | | | |